



BCA 2004

Building Code of Australia

Class 1 and Class 10 Buildings Housing Provisions **VOLUME TWO**

INTRODUCTION - CONTENTS AND FEATURES

SUPERSEDED INTRODUCTION - CONTENTS AND FEATURES

© 2004 Australian Government and States and Territories of Australia

The *BCA 2004 (Volume One & Volume Two)* and the *Guide to the BCA* is the copyright of the Australian Government and States and Territories of Australia and, apart from any use as permitted under the Copyright Act 1998, no part may be reproduced without prior permission. Requests and enquiries concerning reproduction and rights should be directed in the first instance to the Executive Director, Australian Building Codes Board, GPO Box 9839 Canberra ACT 2601.

The *BCA 2004 (Volume One & Volume Two)* and the *Guide to the BCA* is published by CanPrint Communications Pty Ltd on behalf of the ABCB.

Australian Building Codes Board

GPO Box 9839 Canberra ACT 2601

Telephone: Canberra (02) 6213 7240 Facsimile: (02) 6213 7287

Web Site: <http://www.abcb.gov.au>

Email: abcb.office@abcb.gov.au

The Australian Building Codes Board (ABCB) is established by agreement between agreement between the Commonwealth Government and each State and Territory Government. It is a co-operative arrangement between the signatories, local government and the building industry.

CanPrint Communications Pty Ltd (ACN 079 915 932)

Office and Production Facilities: 16 Nyrang St Fyshwick ACT 2609

Telephone: (02) 6295 4422 Facsimile: (02) 6295 4473

Email: canprint@canprint.com.au

CanPrint Communications is an Australian owned company providing integrated printing, publishing, storage and distribution services. These services are supported by national call centre, customer support, inventory and subscriber management facilities.

CanPrint Important Disclaimer

CanPrint does not accept any responsibility for the content of *BCA 2004 (Volume One & Volume Two)* and the *Guide to the BCA*. The *BCA 2004 (Volume One & Volume Two)* and the *Guide to the BCA* has been published as provided by the Australian Building Codes Board.

ABCB Important Disclaimer

The *Guide to the BCA* has been prepared by the ABCB in close consultation with each State and Territory Administration and it endeavours to be as representative as possible of all States' and Territories' views on the intent and provisions of *BCA Volume One*.

Its interpretation in no way overrides the approvals processes in any jurisdiction.

BCA Customer Support

Telephone: 1300 857 522

Facsimile: (02) 6293 83 88

Email: bca@abcb.gov.au

ISBN 1 86264 926 X First published in 1998

GENERAL TABLE OF CONTENTS

INTRODUCTION CONTENTS AND FEATURES

Introduction

SECTION 1 GENERAL REQUIREMENTS

1.0 Application

- 1.0.1 Adoption
- 1.0.2 BCA Volumes
- 1.0.3 BCA Structure
- 1.0.4 Compliance with the BCA
- 1.0.5 Meeting the Performance Requirements
- 1.0.6 Objectives and Functional Statements
- 1.0.7 Deemed-to-Satisfy Provisions
- 1.0.8 Alternative Solutions
- 1.0.9 Assessment Methods
- 1.0.10 Relevant Performance Requirements

1.1 Interpretation

- 1.1.1 Definitions
- 1.1.2 Adoption of referenced documents
- 1.1.3 Context of reference
- 1.1.4 Differences between referenced documents and the Housing Provisions
- 1.1.5 Application of the Housing Provisions to a particular State or Territory
- 1.1.6 Language
- 1.1.7 Interpretation of diagrams
- 1.1.8 Explanatory information

1.2 Acceptance of Design and Construction

- 1.2.1 Suitability of materials
- 1.2.2 Evidence of suitability
- 1.2.3 Fire resistance of building elements
- 1.2.4 Early Fire Hazard Indices

1.3 Classification

- 1.3.1 Principles of classification
- 1.3.2 Classification
- 1.3.3 Multiple classifications

1.4 Standards Adopted by Reference

- 1.4.1 Schedule of referenced documents

SECTION 2 PERFORMANCE PROVISIONS

2.0 Application

2.0 Application

2.1 Structure

P2.1 Structural stability and resistance to actions

2.2 Damp and Weatherproofing

P2.2.1 Surface water

P2.2.2 Weatherproofing

P2.2.3 Dampness

P2.2.4 Drainage from swimming pools

2.3 Fire Safety

P2.3.1 Protection from the spread of fire

P2.3.2 Fire detection and early warning

P2.3.3 Heating appliances

P2.3.4 Bushfire areas

P2.3.5 Alpine areas

2.4 Health and Amenity

P2.4.1 Wet areas

P2.4.2 Room heights

P2.4.3 Facilities

P2.4.4 Light

P2.4.5 Ventilation

P2.4.6 Sound insulation

V2.4.6 Verification methods

2.5 Safe Movement and Access

P2.5.1 Stairways and ramps

P2.5.2 Barriers

P2.5.3 Swimming pool access

2.6 Energy Efficiency

P2.6.1 Building

P2.6.2 Services

V2.6 Definitions

V2.6.1 Application of this Part

V2.6.2 Alternative Verification Methods

V2.6.2.1 Verification using stated value

V2.6.2.2 Verification using a reference building

SECTION 3 ACCEPTABLE CONSTRUCTION

3.0 How to Use Section

Introduction

The scope of these provisions

Suitability of Alternative Solutions

The use of maps

Consultation with appropriate authorities

Layout of Parts 3.1 to 3.12

How to use the requirements of each Part

PART 3.1 SITE PREPARATION

Explanatory Information

3.1.1 Earthworks

- 3.1.1.0 Application
- 3.1.1.1 Earthworks
- 3.1.1.2 Excavation adjacent to vacant adjoining property
- 3.1.1.3 Excavation adjacent to existing buildings
- 3.1.1.4 Fill

3.1.2 Drainage

- 3.1.2.0 Acceptable construction manual
- 3.1.2.1 Application
- 3.1.2.2 Drainage requirements
- 3.1.2.3 Surface water drainage
- 3.1.2.4 Subsoil drainage
- 3.1.2.5 Stormwater drainage

3.1.3 Termite Risk Management

- 3.1 Definitions
- 3.1.3 Application
 - 3.1.3.0 Acceptable construction manual
 - 3.1.3.1 Application
 - 3.1.3.2 Installation of termite barriers
 - 3.1.3.3 Barriers for concrete slab-on-ground
 - 3.1.3.4 Barriers for suspended floors
 - 3.1.3.5 Attachments to buildings

PART 3.2 FOOTINGS AND SLABS

Explanatory Information

3.2 Footings and Slabs

- 3.2 Definitions
- 3.2.0 Acceptable construction manual
- 3.2.1 Application

3.2.2 Preparation

- 3.2.2.1 Excavation for footings
- 3.2.2.2 Filling under concrete slabs
- 3.2.2.3 Foundations for footings and slabs
- 3.2.2.4 Slab edge support on sloping sites
- 3.2.2.5 Stepped footings
- 3.2.2.6 Vapour barriers
- 3.2.2.7 Edge rebates

3.2.3 Concrete and Reinforcing

- 3.2.3.1 Concrete

3.2.3.2 Steel reinforcement

3.2.4 Site Classification

3.2.4.1 Site classification

3.2.5 Footing and Slab Construction

- 3.2.5.1 Footing and slab construction
- 3.2.5.2 Footings and slabs to extensions to existing buildings
- 3.2.5.3 Shrinkage control
- 3.2.5.4 Minimum edge beam dimensions
- 3.2.5.5 Footings for fireplaces on Class A and S sites
- 3.2.5.6 Stump footing details

PART 3.3 MASONRY

3.3 Definitions

3.3.1 Unreinforced Masonry

- 3.3.1.0 Acceptable construction manual
- 3.3.1.1 Application
- 3.3.1.2 External walls
- 3.3.1.3 Internal walls
- 3.3.1.4 Isolated piers
- 3.3.1.5 Masonry units
- 3.3.1.6 Mortar mixes
- 3.3.1.7 Mortar joints
- 3.3.1.8 Vertical articulation joints
- 3.3.1.9 Sub-floor ventilation
- 3.3.1.10 Shrinkage allowance for timber framing

3.3.2 Reinforced Masonry

- 3.3.2.0 Acceptable construction manual
- 3.3.2.1 Application
- 3.3.2.2 External wall construction

3.3.3 Masonry Accessories

- 3.3.3.0 Acceptable construction manual
- 3.3.3.1 Application
- 3.3.3.2 Wall ties
- 3.3.3.3 Fixing straps and tie down systems
- 3.3.3.4 Lintels

3.3.4 Weatherproofing of Masonry

- 3.3.4 Application of this Part
- 3.3.4.0 Acceptable construction manual
- 3.3.4.1 Application
- 3.3.4.2 Width of cavity
- 3.3.4.3 Cavity ventilation and drainage
- 3.3.4.4 Damp-proof courses - materials
- 3.3.4.5 Damp-proof courses - installation
- 3.3.4.6 Flashings

- 3.3.4.7 Location of flashings
- 3.3.4.8 Flashings at the base of cavity walls
- 3.3.4.9 Sill and head flashing
- 3.3.4.10 Flashings at a roof abutting a wall
- 3.3.4.11 Chimney flashings
- 3.3.4.12 Weatherproofing for single skin masonry walls

3.3.5 Earthwall Construction

- 3.3.5 Definitions
- 3.3.5.0 Acceptable construction manual
- 3.3.5.1 Application
- 3.3.5.2 General construction
- 3.3.5.3 Minimum thickness of walls
- 3.3.5.4 Weatherproofing

PART 3.4 FRAMING

3.4.0 Explanation of Terms

- 3.4.0.1 Explanation of terms

3.4.1 Sub-Floor Ventilation

- 3.4.1.1 Application
- 3.4.1.2 Sub-floor ventilation

3.4.2 Steel Framing

- 3.4.2.0 Acceptable construction manual
- 3.4.2.1 Application
- 3.4.2.2 General
- 3.4.2.3 Steel floor framing
- 3.4.2.4 * * *
- 3.4.2.5 * * *
- 3.4.2.6 Installation of services

3.4.3 Timber Framing

- 3.4.3.0 Acceptable construction manual
- 3.4.3.1 * * *
- 3.4.3.2 * * *
- 3.4.3.3 * * *
- 3.4.3.4 * * *
- 3.4.3.5 * * *
- 3.4.3.6 * * *
- 3.4.3.7 * * *
- 3.4.3.8 * * *

3.4.4 Structural Steel Members

- 3.4.4 Explanation of Terms
- 3.4.4.0 Acceptable construction manuals
- 3.4.4.1 Application
- 3.4.4.2 Structural steel members
- 3.4.4.3 Columns
- 3.4.4.4 Corrosion protection

PART 3.5 ROOF AND WALL CLADDING

Explanatory Information

3.5.1 Roof cladding

- 3.5.1.0 Acceptable construction manuals
- 3.5.1.1 Application
- 3.5.1.2 Roof tiling
- 3.5.1.3 Metal sheet roofing

3.5.2 Gutters and downpipes

- 3.5.2.0 Acceptable construction manual
- 3.5.2.1 Application
- 3.5.2.2 Materials
- 3.5.2.3 Selection of guttering
- 3.5.2.4 Installation of gutters
- 3.5.2.5 Downpipes—size and installation

3.5.3 Wall Cladding

- 3.5.3.1 Application
- 3.5.3.2 Timber weatherboard cladding
- 3.5.3.3 Fibre cement planks and weatherboard cladding
- 3.5.3.4 Sheet wall cladding
- 3.5.3.5 Eaves and soffit linings
- 3.5.3.6 Flashings to wall openings

PART 3.6 GLAZING

3.6 Glazing

- 3.6 Definitions
- 3.6.0 Acceptable construction manuals
- 3.6.1 Application
- 3.6.2 Glazing sizes and installation
- 3.6.3 Perimeter framed glazing
- 3.6.4 Human impact safety requirements
- 3.6.5 Doors
- 3.6.6 Side panels
- 3.6.7 Full height framed glazed panels
- 3.6.8 Glazed panels, other than doors or side panels, on the perimeter of rooms
- 3.6.9 Shower doors, shower screens and bath enclosures

PART 3.7 FIRE SAFETY

3.7.1 Fire separation

- 3.7.1.1 Application
- 3.7.1.2 General concession—non-combustible materials
- 3.7.1.3 External walls of Class 1 buildings
- 3.7.1.4 Measurement of distances
- 3.7.1.5 Construction of external walls
- 3.7.1.6 Class 10a buildings
- 3.7.1.7 Allowable encroachments

- 3.7.1.8 Separating walls
- 3.7.1.9 Fire hazard properties
- 3.7.1.10 Roof lights

3.7.2 Smoke alarms

- 3.7.2.1 Application
- 3.7.2.2 Requirements for smoke alarms
- 3.7.2.3 Location—Class 1a buildings
- 3.7.2.4 Location—Class 1b buildings
- 3.7.2.5 Lighting to assist evacuation—Class 1b buildings

3.7.3 Heating appliances

- 3.7.3.0 Acceptable construction manuals
- 3.7.3.1 Application
- 3.7.3.2 Open fireplace construction
- 3.7.3.3 Chimney construction
- 3.7.3.4 Installation of insert fireplaces and flues
- 3.7.3.5 Installation of free standing heating appliances

3.7.4 Bushfire areas

- 3.7.4.0 Acceptable construction manuals
- 3.7.4.1 Application
- 3.7.4.2 Categories of bushfire attack
- 3.7.4.3 Construction requirements

3.7.5 Alpine areas

- 3.7.5.1 Application
- 3.7.5.2 External doorways
- 3.7.5.3 External ramps
- 3.7.5.4 Discharge of external doorways providing a means of egress
- 3.7.5.5 External trafficable structures

PART 3.8 HEALTH AND AMENITY

3.8.1 Wet areas

- 3.8.1 Definitions
- 3.8.1.0 Acceptable construction manual
- 3.8.1.1 * * * * *

3.8.2 Room heights

- 3.8.2.1 Application
- 3.8.2.2 Ceiling heights

3.8.3 Facilities

- 3.8.3.1 Application
- 3.8.3.2 Required facilities
- 3.8.3.3 Construction of sanitary compartments

3.8.4 Light

- 3.8.4.1 Application

- 3.8.4.2 Natural lighting
- 3.8.4.3 Artificial lighting

3.8.5 Ventilation

- 3.8.5.0 Acceptable construction manual
- 3.8.5.1 Application
- 3.8.5.2 Ventilation requirements
- 3.8.5.3 Location of sanitary compartments

3.8.6 Sound insulation

- 3.8.6.1 Application
- 3.8.6.2 Sound insulation requirements
- 3.8.6.3 General installation requirements for walls
- 3.8.6.4 Services

PART 3.9 SAFE MOVEMENT AND ACCESS

3.9.1 Stair construction

- 3.9.1 Definitions
 - 3.9.1.1 Application
 - 3.9.1.2 General requirements
 - 3.9.1.3 Stair construction
 - 3.9.1.4 Riser and going dimensions
 - 3.9.1.5 Threshold

3.9.2 Balustrades

- 3.9.2.1 Application
- 3.9.2.2 When balustrades or other barriers are required
- 3.9.2.3 Balustrades or other barrier construction

3.9.3 Swimming pool access

- 3.9.3.0 Acceptable construction manual
- 3.9.3.1 Application
- 3.9.3.2 Safety fencing location
- 3.9.3.3 Safety fencing construction
- 3.9.3.4 Gates and fittings

PART 3.10 ADDITIONAL CONSTRUCTION REQUIREMENTS

Explanatory Information

3.10.1 High Wind Areas

- 3.10.1.0 Acceptable construction manual

3.10.2 Earthquake Areas

- 3.10.2 Definitions
 - 3.10.2.0 Acceptable construction manuals
 - 3.10.2.1 Application
 - 3.10.2.2 Construction requirements

3.10.2.3 Construction for areas with an acceleration coefficient of 0.12 or more but less than 0.15

3.10.2.4 Construction for areas with an acceleration coefficient of 0.15 or greater

PART 3.11 STRUCTURAL DESIGN MANUALS

Explanatory Information

3.11 Structural design manuals

3.11.1 Application

3.11.2 Resistance to actions

3.11.3 Determination of individual actions

3.11.4 Acceptable structural design manuals

3.11.5 Loading requirements

3.11.6 Determination of structural resistance of materials and forms of construction

PART 3.12 ENERGY EFFICIENCY

3.12 Energy efficiency

3.12 Definitions

3.12.0 Application of Part 3.12

3.12.1 Building fabric

3.12.1 Application

3.12.1.1 Building fabric insulation

3.12.1.2 Roofs

3.12.1.3 Roof lights

3.12.1.4 External walls

3.12.1.5 Floors

3.12.1.6 Attached Class 10a buildings

3.12.2 External Glazing

3.12.2 Application

3.12.2.1 External glazing

3.12.2.2 Shading

3.12.3 Building Sealing

3.12.3 Application

3.12.3.0 A. Acceptable construction manual

3.12.3.1 Chimneys and flues

3.12.3.2 Roof lights

3.12.3.3 External windows and doors

3.12.3.4 Exhaust fans

3.12.3.5 Construction of roofs, walls and floors

3.12.4 Air Movement

3.12.4 Application

3.12.4.1 Air movement

3.12.4.2 Ventilation openings

3.12.4.3 Ceiling fans and evaporative coolers

3.12.5 Services

- 3.12.5 Application
- 3.12.5.0 Acceptable construction manual
- 3.12.5.1 Insulation of services
- 3.12.5.2 Central heating water piping
- 3.12.5.3 Heating and cooling ductwork

APPENDIX A STATE AND TERRITORY ADDITIONS

AUSTRALIAN CAPITAL TERRITORY

Structure

ACT 1 * * * * *

Health and amenity

- ACT 2 Hazardous materials
- ACT 3 Control of Litter on Building Sites
- ACT 4 Waste Management
- ACT 5 Energy Efficiency

Safe movement and access

ACT 6 Swimming pools

NEW SOUTH WALES

New South Wales Additions

- NSW 1.1 Performance Provisions
- NSW 1.2 Acceptable Construction Practice
- NSW2.1 Definitions
- NSW 2.2 Performance Provisions
- NSW 2.3 Acceptable Construction

NORTHERN TERRITORY - No additional provisions

NORTHERN TERRITORY - No additional provisions

QUEENSLAND

Health and Amenity

- QLD 1 * * * * *
- QLD 2 Flashing of Narrow Spaces and Vermin Control

SOUTH AUSTRALIA

Acceptable Construction Manual

SA 1 Application

Health and Amenity

SA 3 Wet Areas

Safe movement and access

- SA 4 Swimming Pool Safety
- SA 5 Access for People with Disabilities
- SA 6 Access for Inspection and Maintenance

TASMANIA

Fire safety

- TAS 1 Non-Combustible Roof Coverings

Safe movement and access

- TAS 2 Swimming Pool Water Reticulation and Filtration

VICTORIA

Health and amenity

- VIC 1 Energy Efficiency

Special requirements for certain buildings and components

WESTERN AUSTRALIA - No additional provisions

WESTERN AUSTRALIA - No additional provisions

INDEX ABBREVIATIONS AND SYMBOLS

Index

Abbreviations and Symbols

HISTORY OF AMENDMENTS

History of amendments

- 1.0 Adoption of BCA96
- 1.1 Amendment No. 1
- 1.2 Amendment No. 2
- 1.3 Amendment No. 3
- 1.4 Amendment No. 4
- 1.5 Amendment No. 5
- 1.6 Amendment No. 6
- 1.7 Amendment No. 7
- 1.8 Amendment No. 8
- 1.9 Amendment No. 9
- 1.10 Amendment No. 10
- 1.11 Amendment No. 11
- 1.12 Amendment No. 12
- 1.13 Amendment No. 13
- 2.0 Adoption of BCA 2004

SUPERSEDED
INTRODUCTION - CONTENTS AND FEATURES

LIST OF AMENDMENTS

List of Amendments Housing Provisions (Volume Two)

INTRODUCTION

THE BUILDING CODE OF AUSTRALIA

The Building Code of Australia (BCA) is produced and maintained by the Australian Building Codes Board (ABCB) on behalf of the Australian Government and each State and Territory Government.

The BCA is a uniform set of technical provisions for the design and construction of buildings and other structures throughout Australia. It allows for variations in climate and geological or geographic conditions.

THE AUSTRALIAN BUILDING CODES BOARD

The ABCB is established by agreement between the Australian Government and each State and Territory Government. It is a co-operative arrangement between the signatories, Local Government and the building industry.

The ABCB's mission is to achieve community expectations of safety, health and amenity in the design, construction and use of buildings through nationally consistent, efficient and cost effective technical building requirements and regulatory systems.

The Board comprises—

- (a) the Australian, State and Territory Governments' principal officer responsible for building regulatory matters; and
- (b) a representative of the Australian Local Government Association (ALGA); and
- (c) industry representatives.

The Building Codes Committee (BCC) is the peak technical advisory body to the ABCB, with responsibility for technical matters associated with the BCA.

The BCC comprises—

- (a) the Executive Director of the ABCB; and
- (b) one nominee each of the Australian, State and Territory Governments and ALGA members of the ABCB; and
- (c) industry members appointed by the ABCB.

THE BCA—CONTENT

GOALS

The goals of the BCA are to enable the achievement and maintenance of acceptable standards of structural sufficiency, safety (including safety from fire), health and amenity for the benefit of the community now and in the future.

These goals are applied so that the BCA extends no further than is necessary in the public interest, is cost effective, easily understood, and is not needlessly onerous in its application.

FORMAT

The BCA is published in two volumes:

SUPERSEDED INTRODUCTION - CONTENTS AND FEATURES

Volume One

pertains primarily to Class 2 to 9 buildings

Volume Two

pertains primarily to Class 1 and 10 buildings (houses, sheds, carports, etc)

Both volumes are drafted in a performance format to provide greater flexibility for the use of new and innovative building products, systems and designs.

A user may choose to comply with the *Deemed-to-Satisfy Provisions* or (described as acceptable construction practice in the *Housing Provisions*) or may use an *Alternative Solution* that satisfies the *Performance Requirements*.

The provisions in this edition are the same as those contained in the preceding edition of the BCA plus changes as detailed in the list located at the back of the document.

STATE AND TERRITORY VARIATIONS AND ADDITIONS

Each State's and Territory's legislation adopts the BCA subject to the variation or deletion of some of its provisions, or the addition of extra provisions. In the *Housing Provisions*, these are divided into two types:

- (a) A variation to the *Housing Provisions*—these are identified following the Clause that is being varied.
- (b) Additional requirements—these are contained in Appendix A .

SCOPE OF THE HOUSING PROVISIONS

Users of the *Housing Provisions* need to be aware that the acceptable construction practices contained in this document do not cover all types of Class 1 and 10 buildings. The limitations of the acceptable construction practices are discussed in the introduction to Section 3.

DEFINITIONS

Words with special meanings are printed in italics and are defined in 1.1.1 or, if they are specific to a Part, at the start of that Part in Section 3. Defined terms which appear in figures and diagrams may not be in italics.

LEGISLATIVE ARRANGEMENTS

GENERAL

The BCA is given legal effect by building regulatory legislation in each State and Territory. This legislation consists of an Act of Parliament and subordinate legislation which empowers the regulation of certain aspects of buildings and structures, and contains the administrative provisions necessary to give effect to the legislation.

Any provision of the BCA may be overridden by, or subject to, State or Territory legislation. The BCA must therefore be read in conjunction with that legislation. Any queries on such matters should be referred to the State or Territory authority responsible for building regulatory matters.

BCA ADOPTION

The adoption of the BCA is addressed in Part 1.0 of the *Housing Provisions*.

DOCUMENTATION OF DECISIONS

Decisions made under the BCA should be fully documented and copies of all relevant documentation should be retained.

Examples of the kind of documentation which should be prepared and retained include:

- (a) Details of the *Building Solution* including all relevant plans and other supporting documentation.
- (b) In cases where an *Alternative Solution* has been proposed—
 - (i) details of the relevant *Performance Requirements*; and
 - (ii) the *Assessment Method* or methods used to establish compliance with the relevant *Performance Requirements*; and
 - (iii) details of any *Expert Judgement* relied upon including the extent to which the judgement was relied upon and the qualifications and experience of the expert; and
 - (iv) details of any tests or calculations used to determine compliance with the relevant *Performance Requirements*; and
 - (v) details of any Standards or other information which were relied upon.

STRUCTURE

The BCA has been structured as set out in 1.0.3 and shown in Figure 1.0.3. It is the ABCB's intent that the *Objectives* and *Functional Statements* be used as an aid to the interpretation of the BCA and not for determining compliance with the BCA.

FURTHER DEVELOPMENT

Regular changes are planned to the BCA to improve clarity of provisions, upgrade referenced documents and to reflect the results of research and improved technology.

COMMENTS

Comments in writing on any matter concerning the text, presentation or further development of the BCA are invited from building and other authorities, industry organisations, professional operatives and the public generally. These comments should be addressed to:

Executive Director

Australian Building Codes Board

GPO Box 9839

CANBERRA ACT 2601

GENERAL REQUIREMENTS

- 1.0 Application**
- 1.1 Interpretation**
- 1.2 Acceptance of Design Classification**
- 1.3 Classification**
- 1.4 Standards adopted by reference**

SECTION 1 CONTENTS

SECTION 1 GENERAL REQUIREMENTS

1.0 Application

- 1.0.1 Adoption
- 1.0.2 BCA Volumes
- 1.0.3 BCA Structure
- 1.0.4 Compliance with the BCA
- 1.0.5 Meeting the Performance Requirements
- 1.0.6 Objectives and Functional Statements
- 1.0.7 Deemed-to-Satisfy Provisions
- 1.0.8 Alternative Solutions
- 1.0.9 Assessment Methods
- 1.0.10 Relevant Performance Requirements

1.1 Interpretation

- 1.1.1 Definitions
- 1.1.2 Adoption of referenced documents
- 1.1.3 Context of reference
- 1.1.4 Differences between referenced documents and the Housing Provisions
- 1.1.5 Application of the Housing Provisions to a particular State or Territory
- 1.1.6 Language
- 1.1.7 Interpretation of diagrams
- 1.1.8 Explanatory information

1.2 Acceptance of Design and Construction

- 1.2.1 Suitability of materials
- 1.2.2 Evidence of suitability
- 1.2.3 Fire resistance of building elements
- 1.2.4 Early Fire Hazard Indices

1.3 Classification

- 1.3.1 Principles of classification
- 1.3.2 Classification
- 1.3.3 Multiple classifications

1.4 Standards Adopted by Reference

- 1.4.1 Schedule of referenced documents

PART 1.0 APPLICATION

1.0.1 Adoption

The dates of adoption of the Building Code of Australia (Volume Two) and its amendments are shown in the “History of BCA Adoption” division at the end of this Volume.

1.0.2 BCA Volumes

- (a) This is Volume Two of the Building Code of Australia (hereafter described as the Housing Provisions) which contains the requirements for—
 - (i) Class 1 and 10 buildings (other than access requirements for people with disabilities in Class 10 buildings); and
 - (ii) certain Class 10 structures.
- (b) Volume One contains the requirements for—
 - (i) all Class 2 to 9 buildings; and
 - (ii) access requirements for people with disabilities in Class 10 buildings ([Part D3](#)); and
 - (iii) certain Class 10 structures.

1.0.3 BCA Structure

The structure of the BCA comprises the following as shown in [Figure 1.0.3](#):

- (a) The *Objectives*.
- (b) The *Functional Statements*.
- (c) The *Performance Requirements* with which all *Building Solutions* must comply.
- (d) The *Building Solutions*.

Figure 1.0.3
THE BCA HIERARCHY

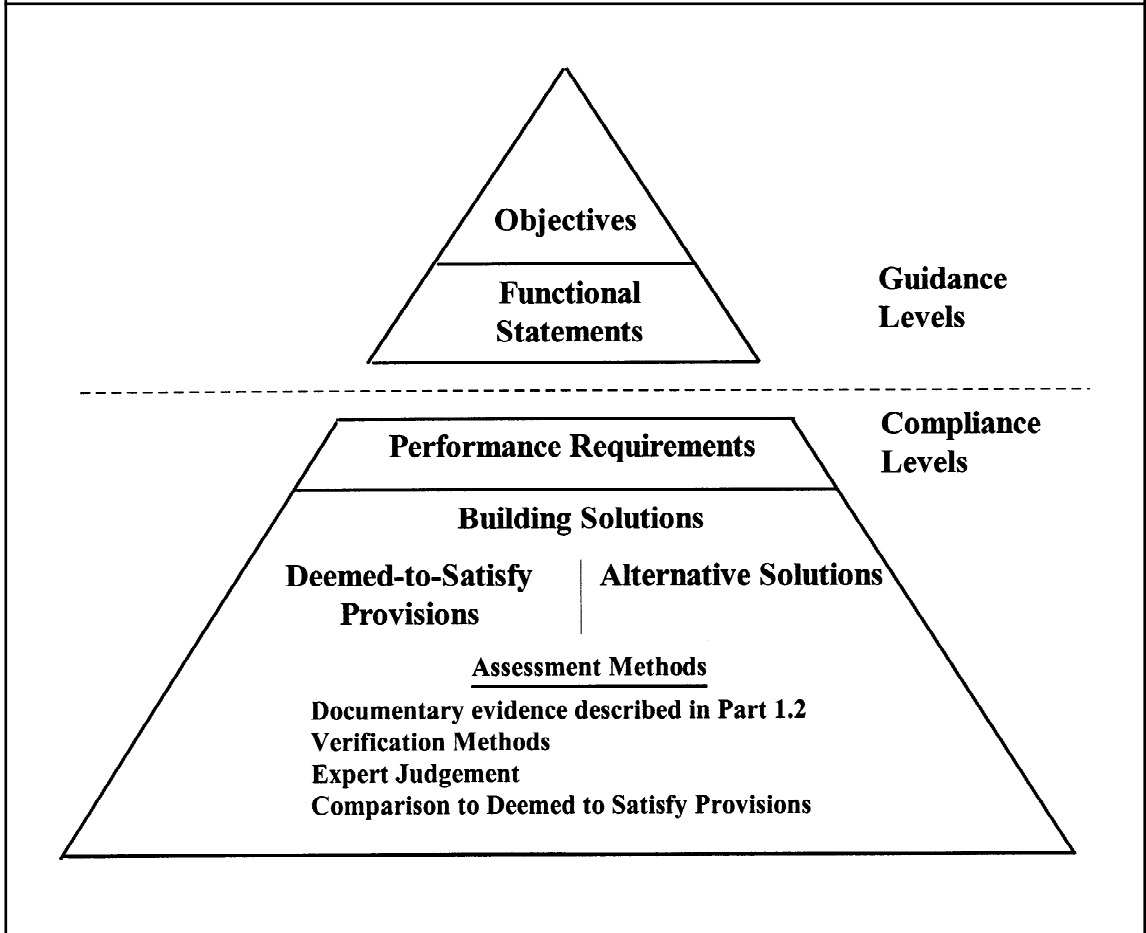

1.0.4 Compliance with the BCA

A *Building Solution* will comply with the BCA if it satisfies the *Performance Requirements*.

1.0.5 Meeting the Performance Requirements

Compliance with the *Performance Requirements* can only be achieved by—

- (a) complying with the *Deemed-to-Satisfy Provisions*; or
- (b) formulating an *Alternative Solution* which—
 - (i) complies with the *Performance Requirements*; or
 - (ii) is shown to be at least *equivalent* to the *Deemed-to-Satisfy Provisions*; or
- (c) a combination of (a) and (b).

1.0.6 Objectives and Functional Statements

The *Objectives* and *Functional Statements* may be used as an aid to interpretation.

1.0.7 Deemed-to-Satisfy Provisions

A *Building Solution* which complies with the *Deemed-to-Satisfy Provisions* is deemed to comply with the *Performance Requirements*.

1.0.8 Alternative Solutions

- (a) An *Alternative Solution* must be assessed according to one or more of the *Assessment Methods*.
- (b) An *Alternative Solution* will only comply with the BCA if the *Assessment Methods* used to determine compliance with the *Performance Requirements* have been satisfied.
- (c) The *Performance Requirements* relevant to an *Alternative Solution* must be determined in accordance with [1.0.10](#).

1.0.9 Assessment Methods

The following *Assessment Methods*, or any combination of them, can be used to determine that a *Building Solution* complies with the *Performance Requirements*:

- (a) Evidence to support that the use of a material, form of construction or design meets a *Performance Requirement* or a *Deemed-to-Satisfy Provision* as described in [1.2.2](#).
- (b) *Verification Methods* such as—
 - (i) the *Verification Methods* in the BCA; or
 - (ii) such other *Verification Methods* as the *appropriate authority* accepts for determining compliance with the *Performance Requirements*.
- (c) Comparison with the *Deemed-to-Satisfy Provisions*.
- (d) Expert Judgement.

1.0.10 Relevant Performance Requirements

The following method must be used to determine the *Performance Requirement* or *Performance Requirements* relevant to an *Alternative Solution*:

- (a) Identify the relevant *Deemed-to-Satisfy Provision* of Section 3 that is to be the subject of the *Alternative Solution*.
- (b) Identify the *Performance Requirements* from Section 2 that are directly relevant to the identified *Deemed-to-Satisfy Provisions*.
- (c) Identify *Performance Requirements* from other parts of Section 2 that are relevant to any aspects of the *Alternative Solution* proposed or that are affected by the application of the *Deemed-to-Satisfy Provisions*, that are the subject of the *Alternative Solution*.

PART 1.1 INTERPRETATION

1.1.1 Definitions

1.1.1.1 In the *Housing Provisions*, definitions are contained as follows:

- (a) In 1.1.1 for definitions that apply to all of the *Housing Provisions*.
- (b) In each Part (as applicable) for definitions that apply to that Part only.

1.1.1.2 In the *Housing Provisions*, unless the contrary appears:

Alpine area means land—

- (a) likely to be subject to significant snowfalls; and
- (b) in New South Wales, ACT or Victoria more than 1200 m above the Australian Height Datum; and
- (c) in Tasmania more than 900 m above the Australian Height Datum.

Explanatory information:

See [Part 3.7.5](#) for map of *alpine areas*.

Alteration , in relation to a building, includes an addition or extension to a building.

Alternative Solution means a *Building Solution* which complies with the *Performance Requirements* other than by reason of complying with the *Deemed-to-Satisfy Provisions*.

Appropriate authority means the relevant authority as determined by the building regulatory legislation in each State and Territory.

Assessment Method means a method used for determining or establishing that a *Building Solution* complies with the *Performance Requirements*.

Automatic , applied to a fire door, smoke door, solid core door, fire shutter, fire *window*, smoke-and-heat vent, sprinkler system, alarm system or the like, means designed to operate when activated by a heat, smoke or fire sensing device.

Average recurrence interval applied to rainfall, means the average or expected interval between events of a given rainfall intensity being exceeded.

Building Solution means a solution which complies with the *Performance Requirements* and is—

- (a) an *Alternative Solution*; or
- (b) a solution which complies with the *Deemed-to-Satisfy Provisions*; or
- (c) a combination of (a) and (b).

Certificate of Accreditation means a certificate issued by a State or Territory accreditation authority stating that the properties and performance of a building material or method of construction or design fulfil specific requirements of the *Housing Provisions*.

Certificate of Conformity means a certificate issued under the ABCB scheme for products and systems certification stating that the properties and performance of a building material or method of construction or design fulfil specific requirements of the *Housing Provisions*.

Climate zone , for the purposes of **Part 2.6** and **Part 3.12**, means an area defined in **Figure 1.1.4** and in **Table 1.1.2** for specific locations, having energy efficiency provisions based on a range of similar climatic characteristics.

Figure 1.1.4

CLIMATE ZONES FOR THERMAL DESIGN

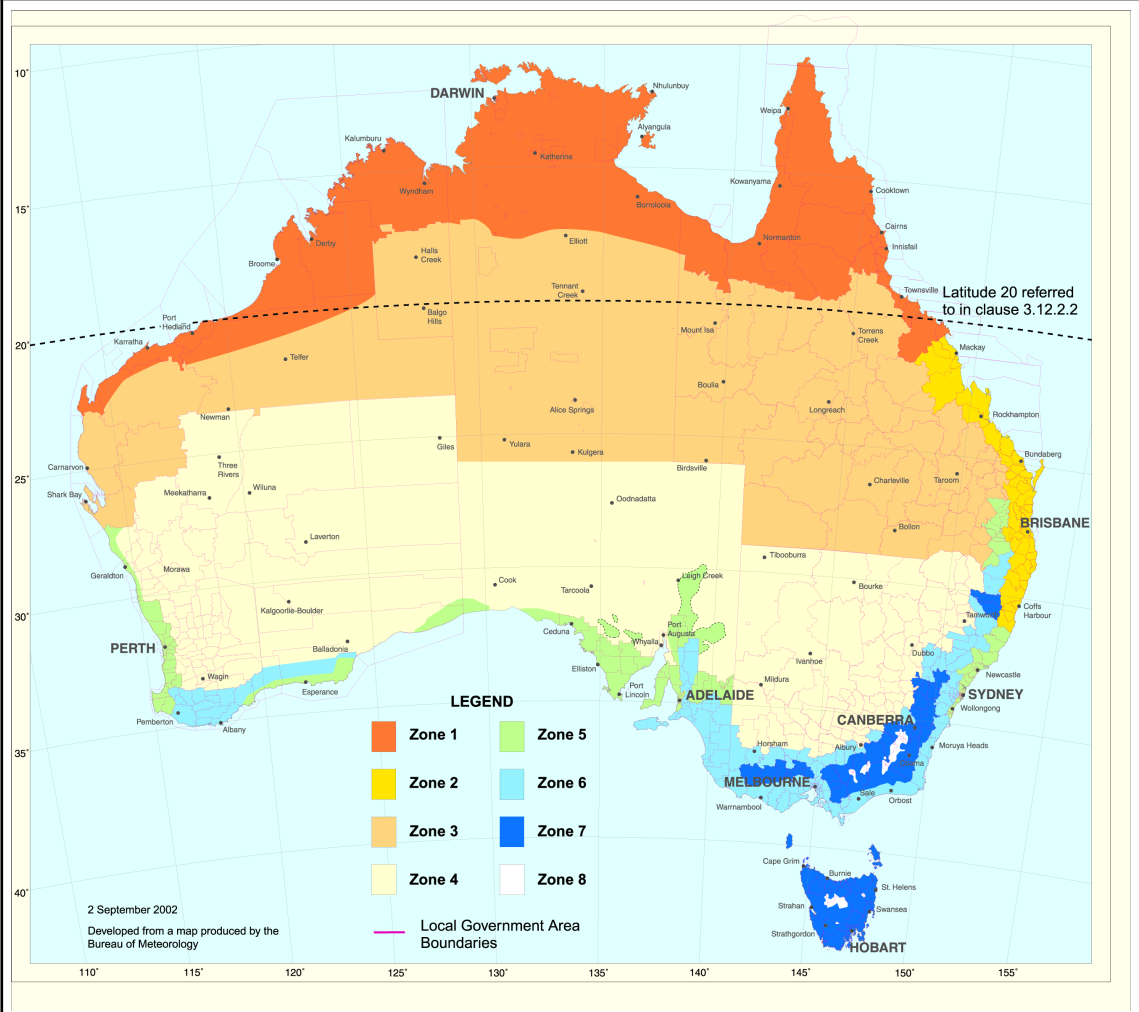

Note:	
1	This map can be viewed in enlargeable form on the ABCB web site at www.abcb.gov.au .
2	A Zone 4 area in South Australia, other than a council area, at an altitude greater than 300 m above Australian Height Datum, is to be considered as Zone 5.

Table 1.1.2 CLIMATE ZONES FOR THERMAL DESIGN—VARIOUS LOCATIONS

Location	<i>Cli- mate zone</i>	Location	<i>Cli- mate zone</i>	Location	<i>Cli- mate zone</i>	Location	<i>Cli- mate zone</i>
Australian Capital Territory				Canberra	7		
New South Wales							
Albury	4	Cobar	4	Lord Howe Island	2	Tamworth	4
Armidale	7	Coffs Harbour	2	Moree	4	Thredbo	8
Batemans Bay	6	Dubbo	4	Newcastle	5	Wagga Wagga	4
Bathurst	6	Goulburn	7	Nowra	6	Williamtown	5
Bega	6	Grafton	2	Orange	7	Wollongong	5
Bourke	4	Griffith	4	Port Macquarie	5	Yass	6
Broken Hill	4	Ivanhoe	4	Sydney - East	5		
Byron Bay	2	Lismore	2	Sydney - West	6		
Northern Territory							
Alice Springs	3	Elliot	3	Renner Springs	3		
Darwin	1	Katherine	1	Tennant Creek	3		
Queensland							
Birdsville	3	Cunnamulla	3	Maryborough	2	Toowoomba	5
Brisbane	2	Longreach	3	Mount Isa	3	Torrens Creek	3
Bundaberg	2	Gladstone	2	Normanton	1	Townsville	1
Cairns	1	Labrador	2	Rockhampton	2	Warwick	5
Cooktown	1	Mackay	2	Roma	3	Weipa	1
South Australia							
Adelaide	5	Kingscote	6	Marree	4	Port Lincoln	5
Bordertown	6	Leigh Creek	5	Mount Gambier	6	Renmark	5
Ceduna	5	Lobethal	6	Murray Bridge	6	Tarcoola	4
Cook	4	Loxton	5	Oodnadatta	4	Victor Harbour	6
Elliston	5	Naracoorte	6	Port Augusta	4	Whyalla	4
Tasmania							
Burnie	7	Flinders Island	7	Launceston	7	Rossarden	7
Bicheno	7	Hobart	7	New Norfolk	7	Smithton	7
Deloraine	7	Huonville	7	Oatlands	7	St Marys	7
Devonport	7	King Island	7	Orford	7	Zeehan	7

Location	<i>Cli- mate zone</i>	Location	<i>Cli- mate zone</i>	Location	<i>Cli- mate zone</i>	Location	<i>Cli- mate zone</i>
Victoria							
Anglesea	6	Bright	7	Horsham	6	Swan Hill	4
Ararat	7	Colac	6	Melbourne	6	Traralgon	6
Bairnsdale	6	Dandenong	6	Mildura	4	Wangaratta	4
Ballarat	7	Echuca	4	Portland	6	Warrnambool	6
Benalla	6	Geelong	6	Sale	6	Wodonga	4
Bendigo	6	Hamilton	7	Shepparton	4		
Western Australia							
Albany	6	Cocos Island	1	Kalgoorlie- Boulder	4	Port Hedland	1
Balladonia	4	Derby	1	Karratha	1	Wagin	4
Broome	1	Esperance	5	Meekatharra	4	Wyndham	1
Bunbury	5	Exmouth	1	Northam	4		
Carnarvon	3	Geraldton	5	Pemberton	6		
Christmas Island	1	Halls Creek	3	Perth	5		

Combustible —

- (a) applied to a material—means *combustible* under AS 1530.1; or
- (b) applied to construction or part of a building—means constructed wholly or in part of *combustible* materials.

Common wall means a wall that is common to adjoining buildings other than Class 1 buildings.

Construction activity actions means actions due to stacking of building materials or the use of equipment, including cranes and trucks, during construction or actions which may be induced by floor-to-floor propping.

Damp-proof course (DPC) means a continuous layer of impervious material placed in a masonry wall or pier, or between a wall or pier and a floor, to prevent the upward or downward migration of water.

Deemed-to-Satisfy Provisions means provisions contained in Section 3 which are deemed to comply with the *Performance Requirements*.

Designated bushfire prone area means land which has been designated under a power in legislation as being subject, or likely to be subject, to bushfires.

STATE AND TERRITORY VARIATIONS

Definition of designated bushfire prone area has been replaced in New South Wales as follows:

Designated bushfire prone area means land that:

- (a) has been designated under legislation; or
 - (b) has been identified under an environmental planning instrument, development control plan or in the course of processing and determining a development application,
- as land that can support a bushfire or is likely to be subject to bushfire attack.

Design wind speed means the design gust wind speed for the area where the building is located, calculated in accordance with AS 1170.2, AS/NZS 1170.2 or AS 4055 (see Table 1.1.1 for *Housing Provisions design wind speed* descriptions and equivalent values).

Table 1.1.1 DESIGN WIND SPEED—EQUIVALENT VALUES

Note:				
1.	Wind classification map identifying cyclonic areas (as per AS 4055) is contained in Part 3.10.1.			
2.	Information on wind speeds for particular areas may be available from the <i>appropriate authority</i> .			
3.		= <i>design wind speed</i> areas covered by Part 3.10.1, High wind areas.		
EQUIVALENT VALUES				
Housing Provisions description	Wind Class—AS 4055			Design gust wind speed (m/sec)
	km/h	For non-cyclonic regions A and B	For cyclonic regions C and D	Permissible stress method only
W28	101	N1	–	28
W33	119	N2	–	33
W41	148	N3	C1	41
W50	180	N4	C2	50
W60	216	N5	C3	60
W70	252	N6	C4	70

Domestic services means the basic engineering systems of a house that use energy or control the use of energy; and—

- (a) includes heating, air-conditioning, mechanical ventilation and hot water systems; but
- (b) excludes cooking facilities and portable appliances.

Envelope , for the purposes of [Part 2.6](#) and [Part 3.12](#), means the parts of a building's *fabric* that separate artificially heated or cooled spaces from—

- (a) the exterior of the building; or
- (b) other spaces that are not artificially heated or cooled.

Equivalent means equivalent to the level of health, safety and amenity provided by the *Deemed-to-Satisfy Provisions*.

Expert Judgement means the judgement of an expert who has the qualifications and experience to determine whether a *Building Solution* complies with the *Performance Requirements*.

External wall means an outer wall of a building which is not a *separating wall*.

Fabric, for the purposes of **Part 2.6** and **Part 3.12**, means the basic building structural elements and components of a building including the roof, ceilings, walls and floors.

Fire-resistance level (FRL) means the grading periods in minutes determined in accordance with **Specification A2.3** of BCA Volume One, for—

- (a) *structural adequacy*; and
- (b) *integrity*; and
- (c) *insulation*,

and expressed in that order.

A dash means there is no requirement for that criterion. For example, 90/–/– means there is no FRL for integrity and insulation.

Fire-resisting, applied to a *structural member* or other part of a building, means having the FRL *required* for that *structural member* or other part.

Flammability Index means the index number determined under AS 1530.2.

Flashing means a strip or sleeve of impervious material dressed, fitted or built-in to provide a barrier to moisture movement, or to divert the travel of moisture, or to cover a joint where water would otherwise penetrate to the interior of a building.

Floor area means, in relation to a room, the area of the room measured within the finished surfaces of the walls, and includes the area occupied by any cupboard or other built-in furniture, fixture or fitting (see **Figure 1.1.1**).

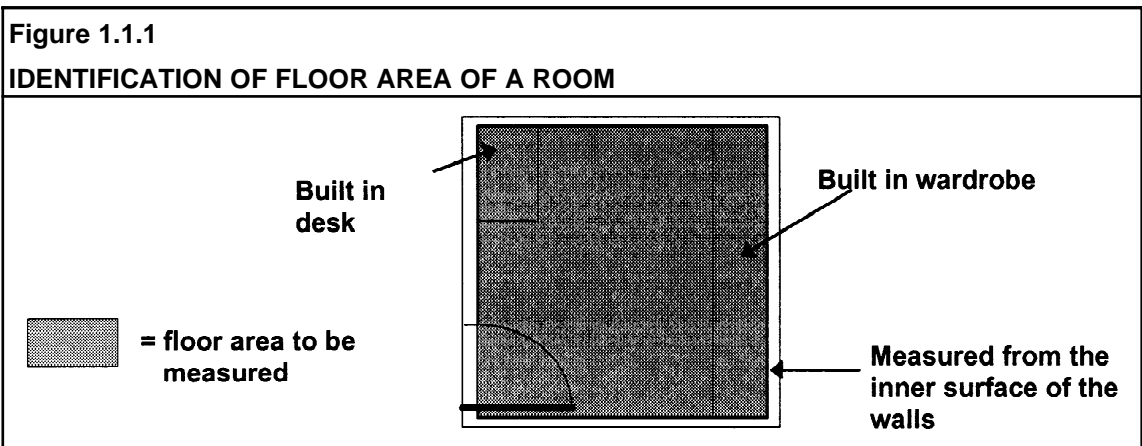

Foundation means the ground which supports the building (see **Figure 1.1.2**).

Figure 1.1.2

IDENTIFICATION OF FOUNDATION

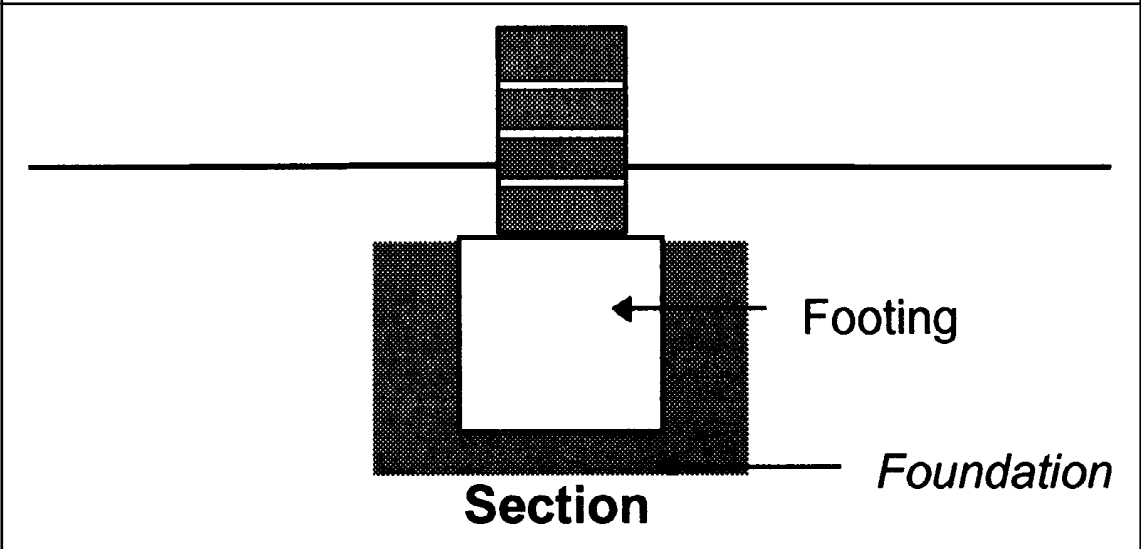

Functional Statement means a statement which describes how buildings and building elements achieve the *Objectives*.

Glazing , for the purposes of [Part 2.6](#) and [Part 3.12](#), means a transparent or translucent element and its supporting frame located in the external *fabric* of the building, and includes a *window* and the glazed part of a door.

Habitable room means a room used for normal domestic activities, and—

- (a) includes a bedroom, living room, lounge room, music room, television room, kitchen, dining room, sewing room, study, playroom, family room and sunroom; but
- (b) excludes a bathroom, laundry, water closet, pantry, walk-in wardrobe, corridor, hallway, lobby, photographic darkroom, clothes-drying room, and other spaces of a specialised nature occupied neither frequently nor for extended periods.

High wind area means a region that is subject to *design wind speeds* more than W41 (see [Table 1.1.1](#)).

Housing Provisions means the requirements for Class 1 and 10 buildings contained in Volume Two of the Building Code of Australia as published by the Australian Building Codes Board.

Illuminance means the luminous flux falling onto a unit area of surface.

Insulation , in relation to an FRL, means the ability to maintain a temperature on the surface not exposed to the furnace below the limits specified in AS 1530.4.

Integrity , in relation to an FRL, means the ability to resist the passage of flames and hot gases specified in AS 1530.4.

Internal wall excludes a *separating wall*, *common wall* or party wall.

Lightweight construction means construction which incorporates or comprises—

- (a) sheet or board material, plaster, render, sprayed application, or other material similarly susceptible to damage by impact, pressure or abrasion; or
- (b) concrete and concrete products containing pumice, perlite, vermiculite, or other soft material similarly susceptible to damage by impact, pressure or abrasion; or
- (c) masonry having a thickness less than 70 mm.

Loadbearing means intended to resist vertical forces additional to those due to its own weight.

Non-combustible —

- (a) applied to a material—means not deemed *combustible* under AS 1530.1—Combustibility Tests for Materials; and
- (b) applied to construction or part of a building—means constructed wholly of materials that are not deemed *combustible*.

Objective means a statement contained in the BCA which is considered to reflect community expectations.

Other property means all or any of the following—

- (a) any building, whether or not on the same or an adjoining allotment; and
- (b) any adjoining allotment; and
- (c) a road.

Outdoor air means air outside the building.

Outfall means that part of the disposal system receiving *surface water* from the drainage system and may include a natural water course, kerb and channel, or soakage system.

Performance Requirement means a requirement which states the level of performance which a *Building Solution* must meet.

Private garage means—

- (a) any garage associated with a Class 1 building; or
- (b) any separate single storey garage associated with another building where such garage is capable of accommodating not more than 3 vehicles.

Professional engineer means a person who is—

- (a) if legislation is applicable—a registered *professional engineer* in the relevant discipline who has appropriate experience and competence in the relevant field; or
- (b) if legislation is not applicable—
 - (i) a Corporate Member of the Institution of Engineers, Australia; or
 - (ii) eligible to become a Corporate Member of the Institution of Engineers, Australia, and has appropriate experience and competence in the relevant field.

Registered Testing Authority means—

- (a) the National Building Technology Centre (NBTC); or
- (b) the CSIRO Division of Building, Construction and Engineering (CSIRO–DBC&E); or
- (c) the Division of Manufacturing & Infrastructure Technology (CSIRO–MIT); or
- (d) an authority registered by the National Association of Testing Authorities (NATA) to test in the relevant field; or
- (e) an organisation outside Australia recognised by NATA through a mutual recognition agreement.

Required means required to satisfy a *Performance Requirement* or a *Deemed-to-Satisfy Provision* of the *Housing Provisions* as appropriate.

Roof light , for the purposes of [Part 2.6](#) and [Part 3.12](#), means a skylight, *window* or the like installed in a roof—

- (a) to permit natural light to enter the room below; and
- (b) at an angle between 0 and 70 degrees measured from the horizontal plane.

Sanitary compartment means a room or space containing a closet pan or urinal.

Sarking-type material means a material such as a reflective foil or other flexible membrane of a type normally used for a purpose such as waterproofing, vapour proofing or thermal reflectance.

Self-closing , applied to a door or *window* means equipped with a device which returns the door or *window* to the fully closed and latched position immediately after each manual opening.

Separating wall means a wall that is common to adjoining Class 1 buildings (see [Figure 1.1.3](#)).

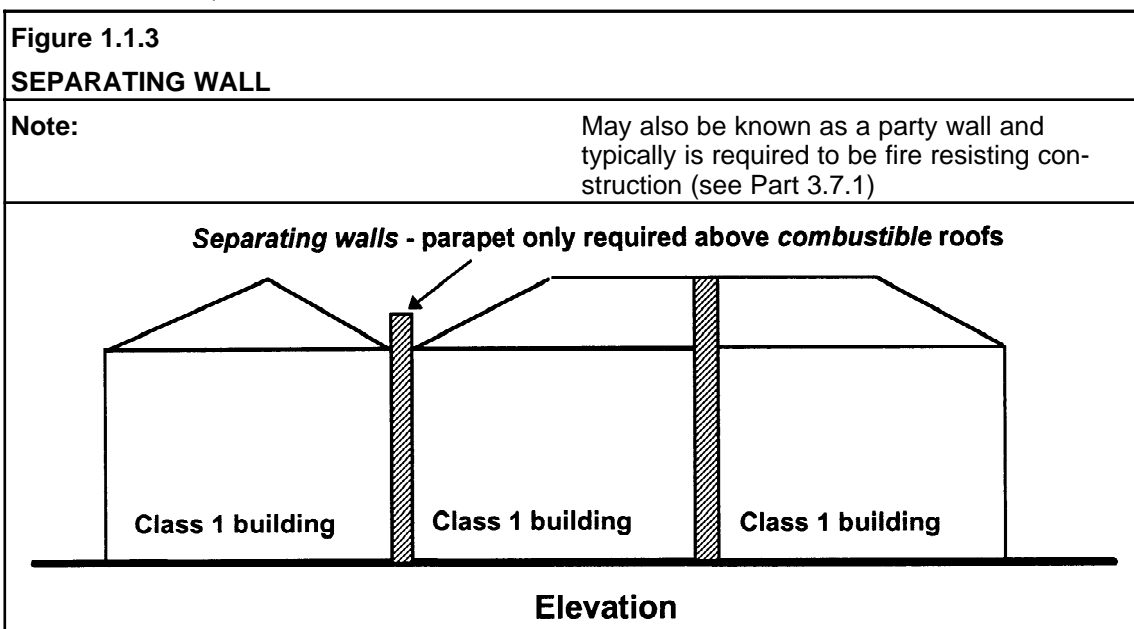

Site means the part of the allotment of land on which a building stands or is to be erected.

Sitework means work on or around a *site*, including earthworks, preparatory to or associated with the construction, *alteration*, demolition or removal of a building.

Smoke-Developed Index means the index number for smoke developed under AS/NZS 1530.3.

Spread-of-Flame Index means the index number for spread of flame under AS/NZS 1530.3.

Standard Fire Test means the Fire-resistance Test of Elements of Building Construction as described in AS 1530.4.

Structural adequacy , in relation to an FRL, means the ability to maintain stability and adequate *loadbearing* capacity under AS 1530.4.

Structural member means a component or part of an assembly which provides vertical or lateral support to a building or structure.

Surface water means all naturally occurring water, other than sub-surface water, which results from rainfall on or around the *site* or water flowing onto the *site*, including that flowing from a drain, stream, river, lake or sea.

Swimming pool means any excavation or structure containing water and used principally for swimming, wading, paddling, or the like, including a bathing or wading pool, or spa.

Verification Method means a test, inspection, calculation or other method that determines whether a *Building Solution* complies with the relevant *Performance Requirements*.

Window includes a roof light, glass panel, glass block or brick, glass louvre, glazed sash, glazed door, or other device which transmits natural light directly from outside a building to the room concerned when in the closed position.

1.1.2 Adoption of referenced documents

Where a *Deemed-to-Satisfy Provision* adopts a Standard, rule, specification or provision included in any document issued by Standards Australia or other body, that adoption does not include a provision—

- (a) specifying or defining the respective rights, responsibilities or obligations as between themselves of any manufacturer, supplier or purchaser; or
- (b) specifying the responsibilities of any trades person or other building operative, architect, engineer, authority, or other person or body; or
- (c) requiring the submission for approval of any material, building component, form or method of construction, to any person, authority or body other than a person or body empowered under State or Territory legislation to give that approval; or
- (d) specifying that a material, building component, form or method of construction must be submitted to Standards Australia or a committee of Standards Australia for expression of opinion; or
- (e) permitting a departure from the code, rule, specification or provision at the sole discretion of the manufacturer or purchaser, or by arrangement or agreement between the manufacturer and purchaser.

1.1.3 Context of reference

- (a) A reference in a *Deemed-to-Satisfy Provision* to a document under 1.1.2 refers to the edition or issue, together with any amendment, listed in Part 1.4 and only so much as is relevant in the context in which the document is quoted.
- (b) Any—
 - (i) reference in a document listed in Part 1.4 (primary document) to another document (secondary document); and
 - (ii) subsequent references to other documents in secondary documents and those other documents;

is a reference to the secondary and other document as they existed at the time of publication of the primary document listed in Part 1.4.

1.1.4 Differences between referenced documents and the Housing Provisions

The *Housing Provisions* overrule in any difference arising between it and any Standard, rule, specification or provision in a document listed in Part 1.4.

1.1.5 Application of the Housing Provisions to a particular State or Territory

For application within a particular State or Territory, the *Housing Provisions* comprise—

- (a) Sections 1 to 3 (inclusive); and
- (b) the variations and deletions applicable to that State or Territory specified in Sections 1 to 3 inclusive; and
- (c) the additions to Sections 1 to 3 inclusive applicable to that State or Territory specified in the relevant Appendix.

1.1.6 Language

A reference to a building in the *Housing Provisions* is a reference to an entire building or part of a building, as the case requires.

1.1.7 Interpretation of diagrams

Diagrams in the *Housing Provisions* are used to describe specific issues referenced in the associated text. They are not to be construed as containing all design information that is *required* for that particular building element or situation.

Explanatory information:

Diagrams are used to explain the requirements of a particular clause. To ensure the context of the requirement is clearly understood, adjacent construction elements of the building that would normally be required in that particular situation are not always shown.

ie: Diagrams to show the installation of *damp-proof courses* will only depict the *damp-proof course* and associated masonry. It will not necessarily show non-related items such as wall ties, adjacent timber flooring, reinforcing for any footing etc.

Accordingly, aspects of a diagram that are not shown should not be interpreted as meaning these construction details are not *required*.

1.1.8 Explanatory information

These elements of the *Housing Provisions* are non-mandatory. They are used to provide additional guidance on the application of the particular Parts and clauses and do not need to be followed to meet the requirements of the *Housing Provisions*.

PART 1.2

ACCEPTANCE OF DESIGN AND CONSTRUCTION

1.2.1 Suitability of materials

Every part of a building must be constructed in an appropriate manner to achieve the requirements of the *Housing Provisions*, using materials that are fit for the purpose for which they are intended.

1.2.2 Evidence of suitability

- (a) Subject to 1.2.3 and 1.2.4, evidence to support that the use of a material, form of construction or design meets a *Performance Requirement* or a *Deemed-to-Satisfy Provision* may be in the form of one or a combination of the following:
- (i) A report issued by a *Registered Testing Authority*, showing that the material or form of construction has been submitted to the tests listed in the report, and setting out the results of those tests and any other relevant information that demonstrates its suitability for use in the building.
 - (ii) A current *Certificate of Conformity* or a current *Certificate of Accreditation*.
 - (iii) A certificate from a *professional engineer* or other appropriately qualified person which—
 - (A) certifies that a material, design or form of construction complies with the requirements of the *Housing Provisions*; and
 - (B) sets out the basis on which it is given and the extent to which relevant specifications, rules, codes of practice or other publications have been relied upon.
 - (iv) A current certificate issued by a product certification body that has been accredited by the Joint Accreditation Scheme of Australia and New Zealand (JAS–ANZ).
 - (v) A current SSL Product Listing Data Sheet and listing in the latest issue of the Scientific Services Laboratory Register of Accredited Products—Fire Protection Equipment.
 - (vi) Any other form of documentary evidence that correctly describes the properties and performance of the material or form of construction and adequately demonstrates its suitability for use in the building.
- (b) Any copy of documentary evidence submitted, must be a complete copy of the original report or document.

1.2.3 Fire resistance of building elements

Where a *Deemed-to-Satisfy Provision* requires a building element to have an FRL, it must comply with the acceptable construction method or be determined in accordance with [Specification A2.3](#) of BCA Volume One.

1.2.4 Early Fire Hazard Indices

Where a *Deemed-to-Satisfy Provision* requires a building component or assembly to have an Early Fire Hazard Index, it must be determined in accordance with **Specification A2.4** of BCA Volume One.

Explanatory information:

The provisions of **Part 1.2** list acceptable methods to enable verification and acceptance of both the performance (listed in **Section 2**) and deemed-to-satisfy options (listed in **Section 3**) of the *Housing Provisions*.

PART 1.3 CLASSIFICATION

1.3.1 Principles of classification

The classification of a building or part of a building is determined by the purpose for which it is designed, constructed or adapted to be used.

Explanatory information:

1. Class 1 and 10 buildings are classified in accordance with this Part; and
2. Class 2 to 9 buildings are classified in accordance with **Section A** of BCA, Volume One.

1.3.2 Classification

Class 1 and 10 buildings are classified as follows:

Class 1—one or more buildings, which in association constitute—

- (a) **Class 1a**—a single dwelling being—
 - (i) a detached house; or
 - (ii) one or more attached dwellings, each being a building, separated by a *fire-resisting* wall, including a row house, terrace house, town house or villa unit; or
- (b) **Class 1b**—a boarding house, guest house, hostel or the like with a total floor area not exceeding 300 m² and in which not more than 12 persons would ordinarily be resident;

which is not located above or below another dwelling or another Class of building other than a *private garage* (see **Figure 1.3.1**, **1.3.2** and **1.3.3**).

Class 10—a non-habitable building or structure being—

- (a) **Class 10a**—a non-habitable building being a *private garage*, carport, shed, or the like; or
- (b) **Class 10b**—a structure being a fence, mast, antenna, retaining or free-standing wall, *swimming pool*, or the like.

(see **Figure 1.3.3**).

Figure 1.3.1
IDENTIFICATION OF CLASS 1 BUILDINGS

Note:

For fire-resisting construction between
Class 1 buildings see Part 3.7.1.

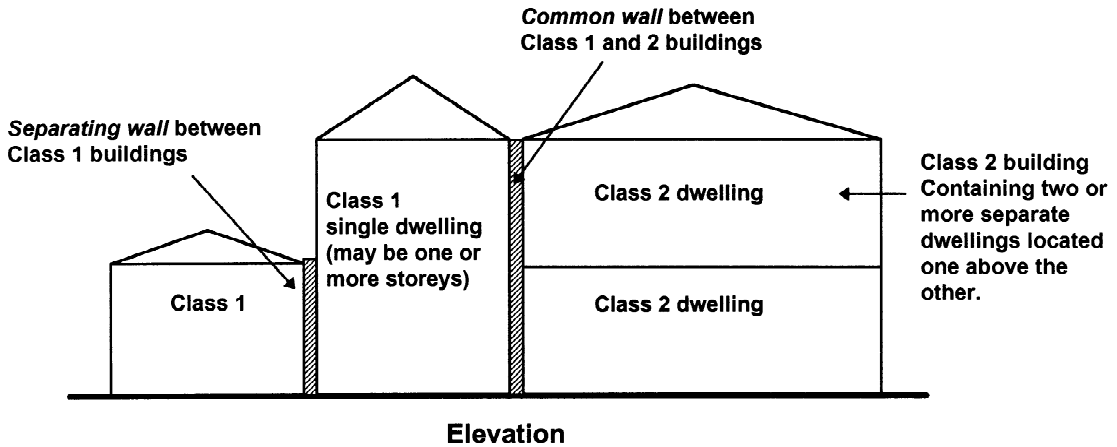
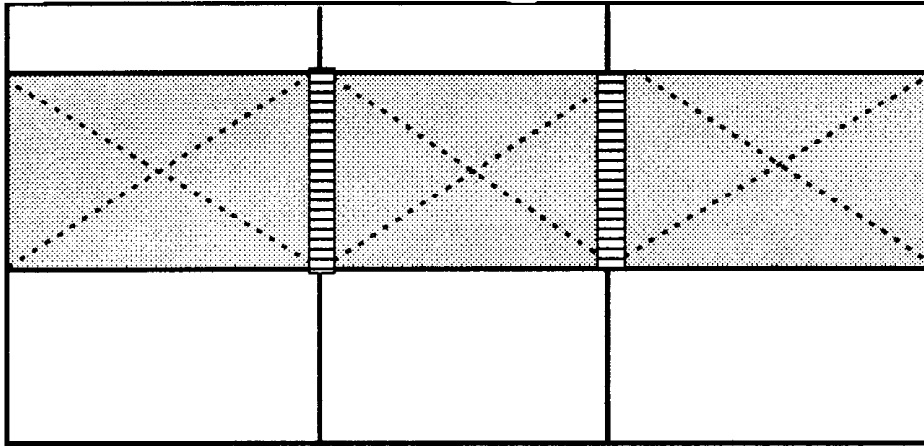
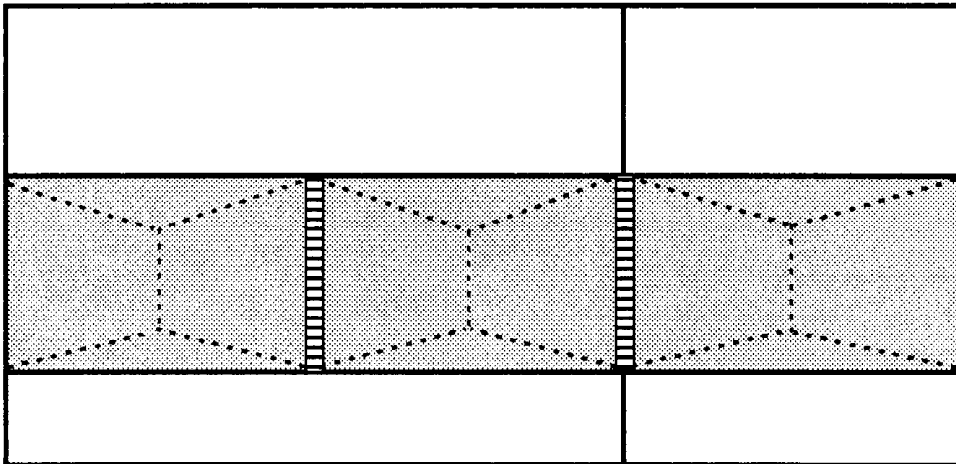

Figure 1.3.2
TYPICAL CLASS 1 CONFIGURATIONS

Note: Legend  = Separating wall



**3 Class 1 buildings on 3
separate allotments**



**3 Class 1 buildings
on 2 separate allotments**

Plan view

Figure 1.3.3

DOMESTIC ALLOTMENT—CLASSIFICATION OF BUILDINGS AND STRUCTURES

- | | | |
|--------------|----|--|
| Note: | 1. | A Class 10 building may be attached to a Class 1 building. |
| | 2. | A Class 1 may consist of one or more buildings (eg detached bedrooms). |

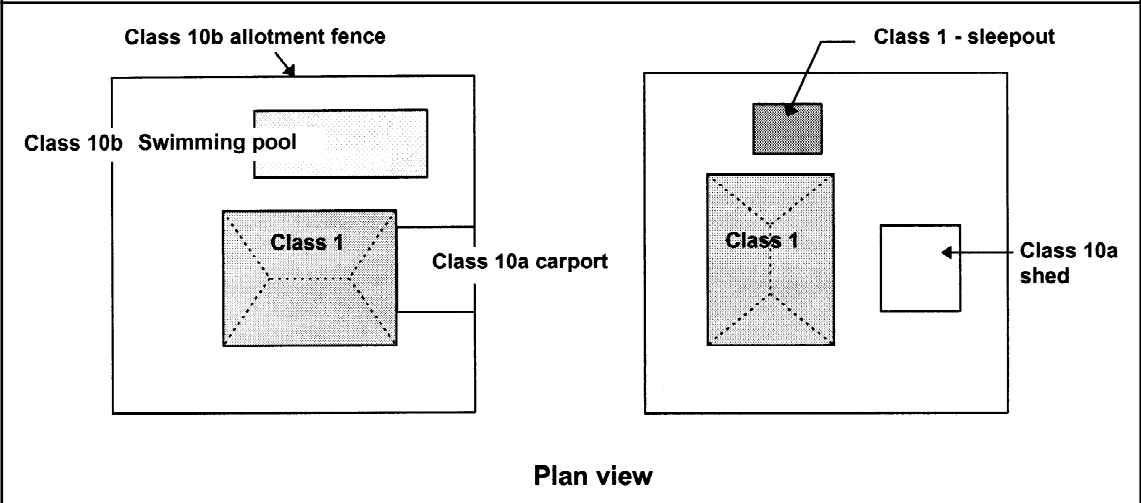

1.3.3 Multiple classifications

Each part of a building must be classified separately, and—

- (a) Classes 1a, 1b, 10a and 10b are separate classifications; and
- (b) a reference to—
 - (i) Class 1—is to Class 1a and 1b; and
 - (ii) Class 10—is to Class 10a and 10b; and
- (c) where parts have different purposes—if not more than 10% of the *floor area* of a Class 1 building is used for a purpose which is a different classification, the classification of Class 1 may apply to the whole building.

SUPERSEDED
GENERAL REQUIREMENTS

PART 1.4 DOCUMENTS ADOPTED BY REFERENCE

1.4.1 Schedule of referenced documents

The Standards and other documents listed in [Table 1.4.1](#) are referred to in the *Housing Provisions*.

Table 1.4.1: SCHEDULE OF REFERENCED DOCUMENTS

	No.	Date	Title
AS/NZS 1170 Amdt No. 11	AS/NZS 1170		Structural design actions
	Part 0	2002	General principles
	Part 1	2002	Permanent, imposed and other actions
	Part 2	2002	Wind actions
AS 1170 Amdt No. 12	AS 1170		Minimum design loads on structures
	Part 1	1989	Dead and live loads and load combinations
			Amdt 1, Jan. 1993
	Part 2	1989	Wind loads
			Amdt 1, Jan. 1991
			Amdt 2, Jan. 1993
			Amdt 3, Dec. 1993
	Part 3	1990	Snow loads
	Part 4	1993	Earthquake loads
			Amdt 1, Oct. 1994
AS/NZS 1200 Amdt No. 8	AS/NZS 1200	2000	Pressure equipment
Deletions Amdt No. 6	AS 1273	1991	Unplasticized PVC (UPVC) downpipe and fittings for rainwater
	AS/NZS 1276		Acoustics—Rating of sound installation in buildings and of building elements
AS/NZS 1276.1 Amdt No. 9	Part 1	1999	Airborne sound insulation

SUPERSEDED
GENERAL REQUIREMENTS

1.4.1

	No.	Date	Title
			[Note: Test reports based on AS 1276—1979 and issued prior to AS/NZS 1276.1—1999 being referenced in the BCA, remain valid. The STC values in reports based on AS 1276—1979 shall be considered to be equivalent to R_w values. Test reports prepared after the BCA reference date for AS/NZS 1276.1—1999 must be based on that version.]
AS 1288 Amdt No. 8	AS 1288	1994	Glass in buildings—Selection and Installation
			Amdt 1, Sept. 1997
			Amdt 2, Dec. 2000
AS 1289 Amdt No. 2	AS 1289		Methods of testing soils for engineering purposes
	Method 6.3.3	1997	Determination of the penetration resistance of a soil—Perth sand penetrometer test
AS 1397 Amdt No. 11	AS 1397	2001	Steel sheet and strip—Hot-dipped zinc-coated or aluminium/zinc-coated
	AS 1530		Methods for fire tests on building materials components and structures
	Part 1	1994	Combustibility test for materials
	Part 2	1993	Test for flammability of materials
			Amdt 1, July 1993
AS 1530.4 Amdt No. 4	Part 4	1997	Fire-resistance tests on elements of building construction
			[Note: Subject to the note to AS 4072.1, reports relating to tests carried out under earlier editions of AS 1530 Parts 1 to 4 remain valid. Reports relating to tests carried out after the date of an amendment to a Standard must relate to the amended Standard]
AS/NZS 1530 Amdt No. 6	AS/NZS 1530		Methods for fire tests on building materials, components and structures
	Part 3	1999	Simultaneous determination of ignitability, flame propagation, heat release and smoke release

SUPERSEDED
GENERAL REQUIREMENTS

1.4.1

	No.	Date	Title	
	AS 1562		Design and installation of sheet roof and wall cladding	
	Part 1	1992	Metal	
				Amdt 1, July 1993
				Amdt 2, Sept. 1995
AS/NZS 1562.2 Amdt No. 6	AS/NZS 1562		Design and installation of sheet roof and wall cladding	
	Part 2	1999	Corrugated fibre-reinforced cement	
AS/NZS 1562.3 Amdt No. 4	Part 3	1996	Plastics	
Deletions Amdt. No. 6	AS 1657	1992	Fixed platforms, walkways, stairways and ladders—Design, construction and installation	
			(SAA Code for Fixed Platforms, Walkways, Stairways and Ladders)	
AS/NZS 1664 Amdt No. 5	AS/NZS 1664		Aluminium structures	
	Part 1	1997	Limit state design	
				Amdt 1, Jan. 1999
	Part 2	1997	Allowable stress design	
				Amdt 1, Jan. 1999
	AS 1668		The use of mechanical ventilation and air-conditioning in buildings	
	Part 2	1991	Mechanical ventilation for acceptable indoor-air quality	
AS/NZS 1680 Amdt No. 13	AS/NZS 1680		Interior lighting	
	Part 0	1998	Safe movement	
AS 1684.2, 3 & 4 Amdt No. 11	AS 1684		Residential timber-framed construction	
	Part 2	1999	Non-cyclonic areas	
				Amdt 1, April 2000
				Amdt 2, Oct. 2000
				Amdt 3, May 2001

SUPERSEDED
GENERAL REQUIREMENTS

1.4.1

	No.	Date	Title
			Amdt 4, May 2002
	Part 3	1999	Cyclonic areas
			Amdt 1, April 2000
			Amdt 2, Oct. 2000
			Amdt 3, May 2001
			Amdt 4, May 2002
	Part 4	1999	Simplified—Non-cyclonic areas
			Amdt 1, April 2000
			Amdt 2, Oct. 2000
			Amdt 3, May 2001
			Amdt 4, May 2002
Deletions Amdt No. 8	AS 1691	1985	Domestic oil-fired appliances—Installation
			Amdt 1, Sept. 1985
AS 1720 Amdt No. 12	AS 1720		Timber structures
			(SAA Timber Structures Code)
	Part 1	1997	Design methods
			Amdt 1, July 1998
			Amdt 2, May 2000
			Amdt 3, April 2001
			Amdt 4, Nov. 2002

SUPERSEDED
GENERAL REQUIREMENTS

1.4.1

	No.	Date	Title
			If AS 1720.1 is being used in conjunction with AS/NZS 1170.0, AS/NZS 1170.1 and AS/NZS 1170.2, it must include Amdt 1 to 4. If AS 1720.1 is being used in conjunction with AS 1170.1 and AS 1170.2, it must only include Amdt 1 to 3.
Deletions Amdt No. 8	AS 1926		Swimming pool safety
AS 1926.1 Amdt No. 7	Part 1	1993	Fencing for swimming pools
			Amdt 1, June 2000
	Part 2	1995	Location of fencing for private swimming pools
AS 2047 Amdt No. 9	AS 2047	1999	Windows in buildings—Selection and installation
			Amdt 1, Jan. 2001
			Amdt 2, June 2001
AS 2049 Amdt No. 13	AS 2049	2002	Roof tiles
AS 2050 Amdt No. 13	AS 2050	2002	Installation of roof tiles
AS 2159 Amdt No. 8	AS 2159	1995	Piling—Design and installation
			Amdt 1, April 1996
	AS/NZS 2179		Specification for rainwater goods, accessories and fasteners
	Part 1	1994	Metal shape or sheet rainwater goods and metal accessories and fasteners
Deletion Amdt No. 9			
AS/NZS 2269 Amdt No. 9	AS/NZS 2269	1994	Plywood-structural
AS/NZS 2269 Amdt No. 9			Amdt 1, Oct. 1996
BCA 2004	AS 2327		Composite structures
	Part 1	2003	Simply supported beams

**SUPERSEDED
GENERAL REQUIREMENTS**

1.4.1

	No.	Date	Title
AS 2464 Amdt No. 12	AS 2464		Method of testing thermal insulation
	Part 3	1983	Thermal resistance of low-density loose-fill insulation
	Part 5	1985	Steady-state thermal transmission properties by means of the heat flow meter
	Part 6	1983	Steady-state thermal transmission properties by means of the guarded hot plate
AS/NZS 2699 Amdt No. 7	AS/NZS 2699		Built in components for masonry construction
	Part 1	2000	Wall ties
	AS 2867	1986	Farm structures—General requirements for structural design
AS 2870 Amdt No. 13	AS 2870	1996	Residential slabs and footings—Construction
			Amdt 1, Jan. 1997
			Amdt 2, June 1999
			Amdt 3, Nov. 2002
			Amdt 4, May 2003
AS/NZS 2904 Amdt No. 3	AS/NZS 2904	1995	Damp-proof courses and flashings
			Amdt 1, March 1998
AS/NZS 2908 Amdt No. 8	AS/NZS 2908		Cellulose cement products
	Part 1	2000	Corrugated sheets
	Part 2	2000	Flat sheets
AS/NZS 2918 Amdt No. 10	AS/NZS 2918	2001	Domestic solid fuel burning appliances—Installation
BCA 2004	AS/NZS 3500		Plumbing and drainage
	Part 3	2003	Storm water drainage
	Part 4	2003	Heated water systems
	Part 5	2000	Domestic installations
Deletions Amdt No. 8	AS 3600	2001	Concrete structures

SUPERSEDED
GENERAL REQUIREMENTS

1.4.1

	No.	Date	Title	
AS 3600 Amdt No. 11				Amdt 1, May 2002
	AS 3623	1993	Domestic metal framing	
AS 3660.1 Amdt No. 8	AS 3660		Termite management	
	Part 1	2000	New building work	
BCA 2004	AS 3700	2001	Masonry structures	
				Amdt 1, May 2002
				Amdt 2, Dec 2003
BCA 2004	AS 3740	2004	Waterproofing of wet areas within residential buildings	
AS 3786 Amdt No. 10BCA 2004	AS 3786	1993	Smoke alarms	
				Amdt 1, April 1994
				Amdt 2, Dec. 1995
				Amdt 3, Nov. 2001
				Amdt 4, Jan. 2004
AS 3798 Amdt No. 2	AS 3798	1996	Guidelines on earthworks for commercial and residential developments	
AS/NZS 3837 Amdt No. 10	AS/NZS 3837	1998	Method of test for heat and smoke release rates for materials and products using an oxygen consumption calorimeter	
AS 3959 Amdt No. 9	AS 3959	1999	Construction of buildings in bushfire-prone areas	
				Amdt 1, Dec. 2000
				Amdt 2, June 2001
	AS 4055	1992	Wind loads for housing	
				Amdt 1, Dec. 1994
AS 4100 Amdt No. 3	AS 4100	1998	Steel Structures	

SUPERSEDED
GENERAL REQUIREMENTS

1.4.1

	No.	Date	Title
	AS/NZS 4200		Pliable building membranes and underlays
	Part 1	1994	Materials
			Amdt 1, Dec. 1994
	Part 2	1994	Installation requirements
AS 4254 Amdt No. 8	AS 4254	1995	Ductwork for air-handling systems in buildings
			Amdt 1, Nov. 1996
			Amdt 2, July 1999
	AS/NZS 4256		Plastic roof and wall cladding material
	Part 1	1994	General requirements
	Part 2	1994	Unplasticized polyvinyl chloride (UPVC) building sheets
Deletions Amdt No. 2	Part 3	1994	Glass fibre reinforced polyester (GRP)
	Part 5	1996	Polycarbonate
	AS/NZS 4600	1996	Cold-formed steel structures
AS/NZS 4859 Amdt No. 13	AS/NZS 4859		Materials for the thermal insulation of buildings
	Part 1	2002	General criteria and technical provisions
ASTM D2898 Amdt No. 7	ASTM D2898	1996	Standard test methods for accelerated weathering of fire-retardant-treated wood for fire testing W1
	ASTM D3018-90	1994	Class A asphalt shingles surfaced with mineral granules
BCA 2004	ABCB	2004	Protocol for House Energy Rating Software, Version 2004.1
	CSIRO—NBTC	1987	Bulletin 5—Earth-wall Construction 4th edition
ISO 717.1 Amdt No. 8	ISO 717		Acoustics—Rating of sound insulation in buildings and of building elements
	Part 1	1996	Airborne sound insulation
ISO 8336 Amdt No. 8	ISO 8336	1993E	Fibre cement flat sheets

SUPERSEDED
GENERAL REQUIREMENTS

1.4.1

	No.	Date	Title
	Northern Territory Deemed to comply Standards manual		
	SSL		Register of Accredited Products—Fire Protection Equipment
	TN 61		Cement and Concrete Association of Australia—Articulated walling
Deletions Amdt No. 8			

STATE AND TERRITORY VARIATIONS—SCHEDULE OF REFERENCED DOCUMENTS

AUSTRALIAN CAPITAL TERRITORY REFERENCED DOCUMENTS			
	No.	Date	Title
Amdt No. 6			Development Control Code for Best Practice Waste Management in the ACT
			Worksafe Australia Asbestos Code of Practice and Guidance Notes, August 1998
NEW SOUTH WALES REFERENCED DOCUMENTS			
AS 1926.3 Amdt No. 13	AS 1926		Swimming pool safety
	Part 3	2003	Water recirculation systems
NSW RFS Planning NSW Amdt No. 12	NSW Rural Fire Service and PlanningNSW	2001	Planning for Bushfire Protection—A Guide for Councils, Planners, Fire Authorities, Developers and Home Owners
SOUTH AUSTRALIAN REFERENCED DOCUMENTS			
South Australian Housing Code 2002 (As amended)			
	* * * * *		
BCA 2004	SA F1.7	2004	South Australian Minister's Specification—Waterproofing of wet areas in buildings—Additional requirements
AS 1428.1 Amdt No. 11	AS 1428		Design for access and mobility
	Part 1	2001	General requirements for access—New building work
BCA 2004	AS 1720.2	1997	Timber Structures
	Part 2		Wind Forces
AS 1926.3 Amdt No. 13	AS 1926		Swimming pool safety
	Part 3	2003	Water recirculation systems
VICTORIAN REFERENCED DOCUMENTS			
BCA 2004	FirstRate		
	Version 3.54	October, 2003	FirstRate house energy rating software, Sustainable Energy Authority Victoria

BCA 2004	NatHERS		
	Version 2.32	August, 2001	Nationwide House Energy Rating Software, CSIRO
BCA 2004	Practice Note		
	2004-55	April, 2004	Residential Sustainability Measures, Building Commission
TASMANIAN REFERENCED DOCUMENTS			
AS 1926.3 Amdt No. 2BCA 2004	AS 1926		Swimming pool safety
	Part 3	2003	Water recirculation systems

PERFORMANCE PROVISIONS

Objectives

Functional Statements

Performance Requirements

- 2.1 Structure**
- 2.2 Damp and Weatherproofing**
- 2.3 Fire safety**
- 2.4 Health and amenity**
- 2.5 Safe movement and access**
- 2.6 Energy Efficiency**

SECTION 2 CONTENTS

SECTION 2 PERFORMANCE PROVISIONS

2.0 Application

2.0 Application

2.1 Structure

P2.1 Structural stability and resistance to actions

2.2 Damp and Weatherproofing

P2.2.1 Surface water

P2.2.2 Weatherproofing

P2.2.3 Dampness

P2.2.4 Drainage from swimming pools

2.3 Fire Safety

P2.3.1 Protection from the spread of fire

P2.3.2 Fire detection and early warning

P2.3.3 Heating appliances

P2.3.4 Bushfire areas

P2.3.5 Alpine areas

2.4 Health and Amenity

P2.4.1 Wet areas

P2.4.2 Room heights

P2.4.3 Facilities

P2.4.4 Light

P2.4.5 Ventilation

P2.4.6 Sound insulation

2.5 Safe Movement and Access

P2.5.1 Stairways and ramps

P2.5.2 Barriers

P2.5.3 Swimming pool access

2.6 Energy Efficiency

P2.6.1 Building

P2.6.2 Services

V2.6 Definitions

V2.6.1 Application of this Part

SUPERSEDED
PERFORMANCE PROVISIONS

V2.6.2 Alternative Verification Methods
V2.6.2.1 Verification using stated value
V2.6.2.2 Verification using a reference building

PART 2.0 APPLICATION

2.0 Application

- (a) This Section contains the *Objectives, Functional Statements* and *Performance Requirements* for Class 1 and 10 buildings (other than access requirements for people with disabilities in Class 10 buildings).
- (b) For the purposes of this Section a reference to a building includes a reference to both Class 1 and 10 buildings unless otherwise specified.

Note:

Access requirements for people with disabilities in Class 10 buildings are contained in [Part D3](#) of the BCA Volume One.

PART 2.1 STRUCTURE

OBJECTIVE

O2.1

The *Objective* is to—

- (a) safeguard people from injury caused by structural failure; and
- (b) safeguard people from loss of amenity caused by structural behaviour; and
- (c) protect *other property* from physical damage caused by structural failure; and
- (d) safeguard people from injury that may be caused by failure of or impact with glazing.

STATE AND TERRITORY VARIATIONS

In Queensland delete O2.1(c) and insert O2.1(c) and (d) as follows:

- (c) protect *other property* from physical damage caused by structural failure; and
- (d) reduce the likelihood of buildings being damaged by subterranean termites.

FUNCTIONAL STATEMENT

F2.1

- (a) A building or structure is to withstand the combination of loads and other actions to which it may be reasonably subjected.
- (b) Glazing is to be installed in a building to avoid undue risk of injury to people.

PERFORMANCE REQUIREMENT

P2.1 Structural stability and resistance to actions

- (a) A building or structure, to the degree necessary, must—
 - (i) remain stable and not collapse; and
 - (ii) prevent progressive collapse; and
 - (iii) minimise local damage and loss of amenity through excessive deformation, vibration or degradation; and

- (iv) avoid causing damage to *other properties*;
by resisting the actions to which it may reasonably be subjected.
- (b) The actions to be considered to satisfy (a) include but are not limited to—
 - (i) permanent actions (dead loads); and
 - (ii) imposed actions (live loads arising from occupancy and use); and
 - (iii) wind action; and
 - (iv) earthquake action; and
 - (v) snow action; and
 - (vi) liquid pressure action; and
 - (vii) ground water action; and
 - (viii) rainwater action (including ponding action); and
 - (ix) earth pressure action; and
 - (x) differential movement; and
 - (xi) time dependent effects (including creep and shrinkage); and
 - (xii) thermal effects; and
 - (xiii) ground movement caused by—
 - (A) swelling, shrinkage or freezing of the subsoil; and
 - (B) landslip or subsidence; and
 - (C) siteworks associated with the building or structure; and
 - (xiv) *construction activity actions*.
- (c) The structural resistance of materials and forms of construction must be determined using five percentile characteristic material properties with appropriate allowance for—
 - (i) known construction activities; and
 - (ii) type of material; and
 - (iii) characteristics of the site; and
 - (iv) the degree of accuracy inherent in the methods used to assess the structural behaviour; and
 - (v) action effects arising from the differential settlement of foundations, and from restrained dimensional changes due to temperature, moisture, shrinkage, creep and similar effects.
- (d) Glass installations that are at risk of being subjected to human impact must have glazing that—
 - (i) if broken on impact, will break in a way that is not likely to cause injury to people; and
 - (ii) resists a reasonably foreseeable human impact without breaking; and
 - (iii) is protected or marked in a way that will reduce the likelihood of human impact.

STATE AND TERRITORY VARIATIONS

In Queensland after P2.1 insert P2.1.1 as follows:

P2.1.1 All *primary building elements* of a Class 1 and 10 building must be protected against damage by subterranean termites by a suitable termite management system appropriate to—

- (a) the ability to replenish the termite management system if it relies on replenishment; and
- (b) the level of accessibility to enable the installation, maintenance and inspection of the termite management system to be carried out; and
- (c) the likelihood of the termite management system inadvertently being damaged or bridged.

PART 2.2 DAMP AND WEATHERPROOFING

OBJECTIVE

O2.2

The *Objective* is to—

- (a) safeguard occupants from illness or injury and protect the building from damage caused by—
 - (i) *surface water*, and
 - (ii) external moisture entering a building; and
 - (iii) the accumulation of internal moisture in a building; and
 - (iv) discharge of *swimming pool* waste water; and
- (b) protect *other property* from damage caused by—
 - (i) redirected *surface water*, and
 - (ii) the discharge of *swimming pool* waste water.

STATE AND TERRITORY VARIATIONS

O2.2(a)(iv) and O2.2(b)(ii) do not apply in the Northern Territory.

FUNCTIONAL STATEMENT

F2.2.1 Surface water

A building including any associated *sitework* is to be constructed in a way that protects people and *other property* from the adverse effects of redirected *surface water*.

F2.2.2 Weatherproofing and dampness

A building is to be constructed to provide resistance to moisture from the outside and moisture rising from the ground.

Limitation:

F2.2.2 does not apply to a Class 10 building except where its construction contributes to the weatherproofing of the Class 1 building.

F2.2.3 Drainage from swimming pools

Adequate means for the disposal of *swimming pool* water and drainage is to be provided to a *swimming pool*.

Note:

The *Housing Provisions* do not contain any *Deemed-to-Satisfy Provisions* for this *Performance Requirement*.

STATE AND TERRITORY VARIATIONS

F2.2.3 does not apply in the Northern Territory.

PERFORMANCE REQUIREMENT

P2.2.1 Surface water

- (a) *Surface water*, resulting from a storm having an *average recurrence interval* of 20 years and which is collected or concentrated by a building or *sitework*, must be disposed of in a way that avoids the likelihood of damage or nuisance to any *other property*.
- (b) *Surface water*, resulting from a storm having an *average recurrence interval* of 100 years must not enter the building.

Limitation:

P2.2.1(b) does not apply to a Class 10 building where in the particular case there is no necessity for compliance.

- (c) A drainage system for the disposal of *surface water* must—
 - (i) convey *surface water* to an appropriate *outfall*; and
 - (ii) avoid the entry of water into a building; and
 - (iii) avoid water damaging the building.

P2.2.2 Weatherproofing

A roof and *external wall* (including openings around *windows* and doors) must prevent the penetration of water that could cause—

- (a) unhealthy or dangerous conditions, or loss of amenity for occupants; and
- (b) undue dampness or deterioration of building elements.

Limitation:

P2.2.2(a) does not apply to a Class 10 building except where its construction contributes to the weatherproofing of the Class 1 building.

P2.2.3 Dampness

Moisture from the ground must be prevented from causing—

- (a) unhealthy or dangerous conditions, or loss of amenity for occupants; and
- (b) undue dampness or deterioration of building elements.

Limitation:

P2.2.3 does not apply to a Class 10 building where in the particular case there is no necessity for compliance.

STATE AND TERRITORY VARIATIONS

P2.2.3 has been replaced in South Australia as follows.

P2.2.3 Dampness

- (a) Moisture from the ground must be prevented from causing—
 - (i) undue dampness or deterioration of building elements; and
 - (ii) unhealthy or dangerous conditions, or loss of amenity for occupants.
- (b) Barriers installed to prevent transfer of moisture from the ground must have—
 - (i) high resistance to moisture penetration; and
 - (ii) high resistance to damage during construction; and
 - (iii) high resistance to degradation by dissolved salts.

In New South Wales delete P2.2.3 and insert NSW P2.2.3 as follows:

NSW P2.2.3 Dampness

- (a) Moisture from the ground must be prevented from causing—
 - (i) unhealthy or dangerous conditions, or loss of amenity for occupants; and
 - (ii) undue dampness or deterioration of building elements.
- (b) Barriers installed beneath slab on ground construction for the purposes of (a) must have a high resistance to damage during construction.

Limitation:

P2.2.3 does not apply to a Class 10 building where in the particular case there is no necessity for compliance.

Explanatory information:

The intent of requiring the barrier to have a high resistance to damage during construction is to increase the barrier's ability to resist punctures during construction. By being less susceptible to puncturing, the barrier will provide increased protection against moisture containing dissolved salts from coming into contact with the concrete slab.

P2.2.4 Drainage from swimming pools

A *swimming pool* must have adequate means of draining the pool in a manner which will not—

- (a) cause illness to people; or
- (b) affect *other property*.

Note:

The *Housing Provisions* do not contain any *Deemed-to-Satisfy Provisions* for this *Performance Requirement*.

STATE AND TERRITORY VARIATIONS

P2.2.4 does not apply in the Northern Territory.

PART 2.3 FIRE SAFETY

OBJECTIVE

O2.3

The *Objective* is to—

- (a) safeguard the occupants from illness or injury—
 - (i) by alerting them of a fire in the building so that they may safely evacuate; and
 - (ii) caused by fire from heating appliances installed within the building; and
 - (iii) in *alpine areas*, from an emergency while evacuating the building; and
- (b) avoid the spread of fire; and
- (c) protect a building from the effects of a bushfire.

FUNCTIONAL STATEMENT

F2.3.1 Protection from the spread of fire

A Class 1 building is to be protected from the spread of fire.

F2.3.2 Fire detection and early warning

A Class 1 building is to be provided with safeguards so that occupants are warned of a fire in the building so that they may safely evacuate.

F2.3.3 Heating appliances

Heating appliances using controlled combustion located in a building are to be installed in a way which reduces the likelihood of—

- (a) fire spreading beyond the appliance; and
- (b) smoke from the appliance entering the building.

F2.3.4 Bushfire areas

A Class 1 building constructed in a *designated bushfire prone area* is to provide resistance to bushfires in order to reduce the danger to life and reduce the risk of the loss of the building.

F2.3.5 Alpine areas

A building in an *alpine area* is to be provided with additional measures in view of the increased difficulties in fighting fire and maintaining access and means of egress in snow conditions.

PERFORMANCE REQUIREMENT

P2.3.1 Protection from the spread of fire

- (a) A Class 1 building must be protected from the spread of fire from—
 - (i) another building other than an associated Class 10 building; and
 - (ii) the allotment boundary, other than a boundary adjoining a road or public space.
 (see [Figure 2.3.1](#))
- (b) A Class 10a building must not significantly increase the risk of fire spread between Class 2 to 9 buildings.

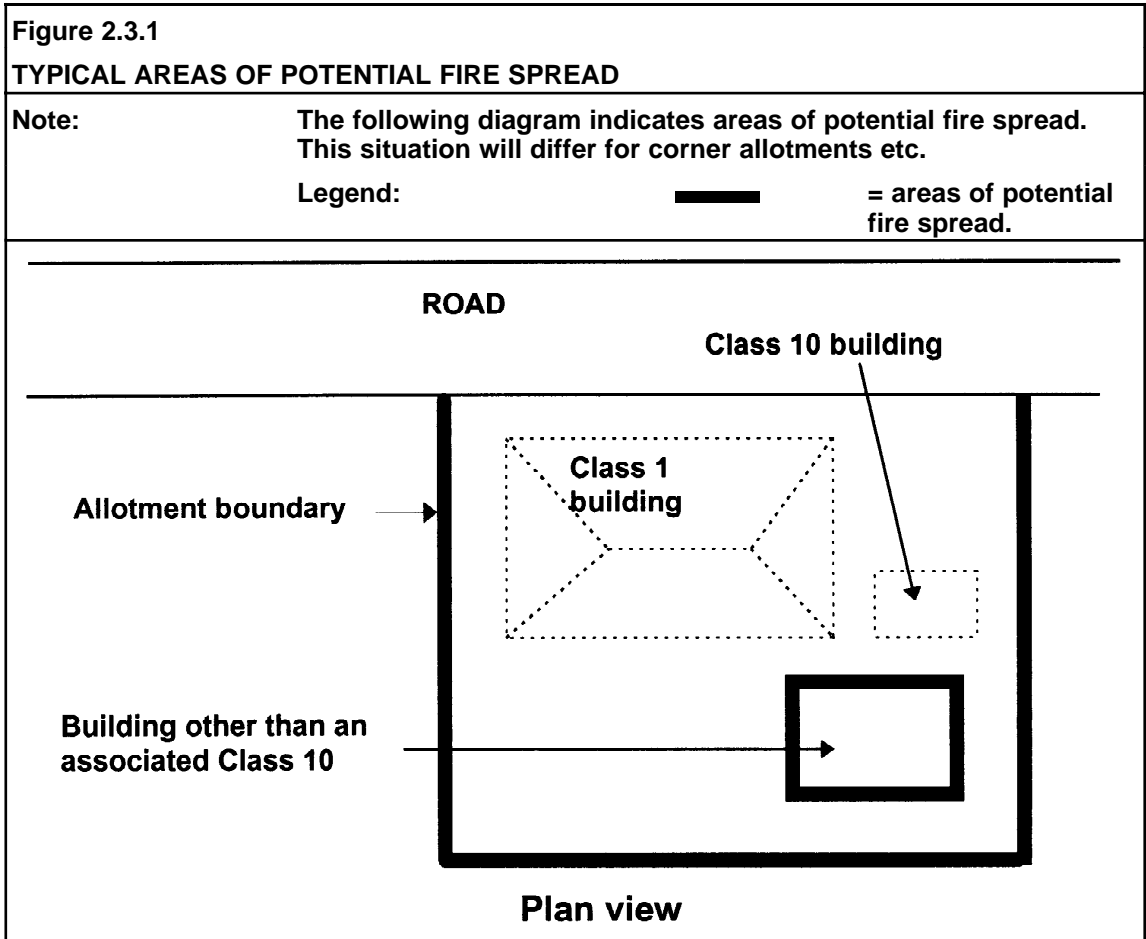

P2.3.2 Fire detection and early warning

In a Class 1 building, occupants must be provided with *automatic* warning on the detection of smoke so that they may evacuate in the event of a fire to a place of safety.

P2.3.3 Heating appliances

A heating appliance and its associated components within a building, including an open fire-place, chimney, or the like, must be installed—

- (a) to withstand the temperatures likely to be generated by the appliance; and
- (b) so that it does not raise the temperature of any building element to a level that would adversely affect the element's physical or mechanical properties or function; and
- (c) so that hot products of combustion will not—
 - (i) escape through the walls of the associated components; and
 - (ii) discharge in a position that will cause fire to spread to nearby *combustible* materials or allow smoke to penetrate through nearby *windows*, ventilation inlets, or the like in the building containing the heating appliance.

P2.3.4 Bushfire areas

A Class 1 building that is constructed in a *designated bushfire prone area* must be designed and constructed to reduce the risk of ignition from a bushfire while the fire front passes.

P2.3.5 Alpine areas

- (a) An external doorway from a building in an *alpine area* must be installed so that opening the door is not obstructed by snow or ice.
- (b) A building in an *alpine area* containing external trafficable structures forming part of the means of egress must be constructed so that they remain, as far as practicable, useable under snow conditions.
- (c) A building in an *alpine area* must be constructed so that snow or ice is not shed from the building onto the allotment, any adjoining allotment, road or public space in a location or manner that will—
 - (i) obstruct a means of egress from any building to a road or *open space*; or
 - (ii) otherwise endanger people.

PART 2.4 HEALTH AND AMENITY

OBJECTIVE

O2.4.1 Wet areas

The *Objective* is to safeguard the occupants from illness or injury and protect the building from damage caused by the accumulation of internal moisture arising from the use of *wet areas* in a building.

O2.4.2 Room heights

The *Objective* is to safeguard the occupants from injury or loss of amenity caused by inadequate height of a room or space.

O2.4.3 Facilities

The *Objective* is to—

- (a) safeguard occupants from illness caused by infection; and
- (b) safeguard occupants from loss of amenity arising from the absence of adequate personal hygiene facilities; and
- (c) enable occupants to carry out laundering; and
- (d) provide for facilities to enable food preparation; and
- (e) enable unconscious occupants of *sanitary compartments* to be removed from the compartment.

O2.4.4 Light

The *Objective* is to safeguard occupants from injury, illness or loss of amenity due to—

- (a) isolation from natural light; and
- (b) lack of adequate artificial lighting.

O2.4.5 Ventilation

The *Objective* is to safeguard occupants from illness or loss of amenity due to lack of air freshness.

O2.4.6 Sound insulation

The *Objective* is to safeguard occupants from illness or loss of amenity as a result of undue sound being transmitted between adjoining dwellings.

FUNCTIONAL STATEMENT

F2.4.1 Wet areas

A building is to be constructed to avoid the likelihood of—

- (a) the creation of any unhealthy or dangerous conditions; or
- (b) damage to building elements,

caused by dampness or water overflow from bathrooms, laundries and the like.

F2.4.2 Room heights

A building is to be constructed to provide height in a room or space suitable for the intended use.

F2.4.3 Facilities

A building is to be provided with suitable—

- (a) space and facilities for personal hygiene; and
- (b) space and facilities for laundering; and
- (c) space and facilities for the preparation and cooking of food; and
- (d) space or other means to permit an unconscious occupant to be removed from a *sanitary compartment*.

Application:

F2.4.3 only applies to a Class 1 building.

F2.4.4 Light

- (a) A *habitable room* within a building is to be provided with openings to admit adequate natural light consistent with its function or use; and
- (b) A space within a building used by occupants is to be provided with artificial lighting consistent with its function or use which, when activated in the absence of suitable natural light, will enable safe movement.

F2.4.5 Ventilation

A space used by occupants within a building is to be provided with adequate ventilation consistent with its function or use.

F2.4.6 Sound insulation

A building element which separates dwellings is to be constructed to prevent undue sound transmission between those dwellings.

PERFORMANCE REQUIREMENT

P2.4.1 Wet areas

To protect the structure of the building and to maintain the amenity of the occupants, water must be prevented from penetrating—

- (a) behind fittings and linings; or
 - (b) into concealed spaces,
- of sanitary facilities, bathrooms, laundries and the like.

P2.4.2 Room heights

A room or space must be of a height that does not unduly interfere with its intended function.

P2.4.3 Facilities

- (a) Suitable sanitary facilities for personal hygiene must be provided in a convenient location within or associated with a building, appropriate to its function or use.
- (b) * * * * *

This clause has been deliberately left blank.

- (c) Laundering facilities or space for laundering facilities must be provided in a convenient location within or associated with a building, appropriate to its function or use.
- (d) A food preparation facility must be provided which includes—
 - (i) a means for food rinsing, utensil washing and waste water disposal; and
 - (ii) a means for cooking food; and
 - (iii) a space for food preparation.
- (e) A *sanitary compartment* must be constructed with sufficient space or other means to enable an unconscious occupant to be removed from the compartment.

Application:

P2.4.3 only applies to a Class 1 building.

P2.4.4 Light

- (a) A *habitable room* must be provided with *windows* so that natural light, when available, provides a level of *illuminance* appropriate to the function or use of that part of the building.
- (b) Artificial lighting must be installed to provide a level of *illuminance* appropriate to the function or use of the building to enable safe movement by occupants.

Application:

P2.4.4(b) only applies—

- (a) to *sanitary compartments*, bathrooms, shower rooms, airlocks, laundries and the like; and

- (b) if natural lighting of a suitable standard is not available.

P2.4.5 Ventilation

- (a) A space within a building used by occupants must be provided with means of ventilation with *outdoor air* which will maintain adequate air quality.
- (b) A mechanical air-handling system installed in a building must control—
- (i) the circulation of objectionable odours; and
 - (ii) the accumulation of harmful contamination by micro-organisms, pathogens and toxins.
- (c) Contaminated air must be disposed of in a manner which does not unduly create a nuisance or hazard to people in the building or *other property*.

P2.4.6 Sound insulation

- (a) Walls separating dwellings must provide insulation against the transmission of airborne sound sufficient to prevent illness or loss of amenity to the occupants.
- (b) Walls separating a bathroom, *sanitary compartment*, laundry or kitchen in a dwelling from a *habitable room* (other than a kitchen) in an adjoining dwelling, must provide insulation against impact generated sound sufficient to prevent illness or loss of amenity to the occupants.
- (c) The *required* sound insulation of walls must not be compromised by the incorporation or penetration of a pipe or other service element.

STATE AND TERRITORY VARIATIONS

In Northern Territory, Queensland and Western Australia P2.4.6 is replaced with the following.

P2.4.6 Sound insulation

- (a) Walls separating dwellings must provide insulation against the transmission of airborne and impact generated sound sufficient to prevent illness or loss of amenity to the occupants.
- (b) The *required* sound insulation of walls must not be compromised by the incorporation or penetration of a pipe or other service element.

VERIFICATION METHOD

V2.4.6 Sound insulation

Compliance with P2.4.6(a) and (c) to insulate against transmission of airborne sound through walls separating dwellings is verified when it is measured that the wall has a weighted standardised level difference with spectrum adaptation term ($D_{nT,w} + C_{tr}$) not less than 45 when determined under AS/NZS 1276.1 or ISO 717.1.

STATE AND TERRITORY VARIATIONS

V2.4.6 does not apply in Northern Territory, Queensland and Western Australia.

PART 2.5 SAFE MOVEMENT AND ACCESS

OBJECTIVE

O2.5

The *Objective* is to—

- (a) provide people with safe access to and within a building; and
- (b) safeguard young children from drowning or injury in a *swimming pool*.

Application:

O2.5 only applies to a *swimming pool* with a depth of water more than 300 mm.

STATE AND TERRITORY VARIATIONS

1. **O2.5(b) does not apply in New South Wales.**

Note: Restriction of access to swimming pools in New South Wales is regulated under the Swimming Pools Act 1992.

2. **O2.5(b) does not apply in the Northern Territory.**

3. **O2.5(b) does not apply in Queensland.**

Note: Restriction of access to swimming pools in Queensland is regulated under the Building Act 1975.

4. **O2.5(b) does not apply in Western Australia.**

Note: Restriction of access to private swimming pools in Western Australia is regulated under the Local Government (Miscellaneous Provisions) Act 1960 and the Building Regulations 1989 as amended.

FUNCTIONAL STATEMENT

F2.5.1 Safety from falling

A building is to provide safe access for people to the services and facilities within.

F2.5.2 Swimming pool access

A *swimming pool* is to be provided with means to restrict access to it by young children.

Application:

F2.5.2 only applies to a *swimming pool* with a depth of water more than 300 mm.

STATE AND TERRITORY VARIATIONS

1. **F2.5.2 does not apply in New South Wales.**

Note: Restriction of access to *swimming pools* in New South Wales is regulated under the Swimming Pools Act 1992.

2. **F2.5.2 does not apply in the Northern Territory.**

3. **F2.5.2 does not apply in Queensland.**

Note: Restriction of access to *swimming pools* in Queensland is regulated under the Building Act 1975.

4. **F2.5.2 does not apply in Western Australia.**

Note: Restriction of access to *swimming pools* in Western Australia is regulated under the Local Government (Miscellaneous Provisions) Act 1960 and the Building Regulations 1989 as amended.

PERFORMANCE REQUIREMENT

P2.5.1 Stairways and ramps

So that people can move safely to and within a building—

- (a) walking surfaces must have safe gradients; and
- (b) any stairway or ramp must—
 - (i) * * * * *

This clause has been deliberately left blank.

- (i) have suitable landings to avoid undue fatigue of users; and
- (iii) be suitable for safe passage in relation to the nature, volume and frequency of likely usage; and
- (iv) have slip-resistant walking surfaces on ramps, and on stairway treads or near the edge of the nosing.

P2.5.2 Barriers

Where people could fall 1 m or more—

- (a) from a floor or roof of a building or through an opening (other than through an openable *window*) in the *external wall*; or
- (b) due to a sudden change of level within or associated with a building, a barrier must be provided which must be—
- (c) continuous and extend for the full extent of the hazard; and
- (d) of a height to protect people from accidentally falling from the floor or roof or through the opening; and
- (e) constructed to prevent people from falling through the barrier; and
- (c) capable of restricting the passage of children; and
- (d) of strength and rigidity to withstand—
 - (i) the foreseeable impact of people; and
 - (ii) where appropriate, the static pressure of people pressing against it.

P2.5.3 Swimming pool access

A barrier must be provided to a *swimming pool* and must—

- (a) be continuous for the full extent of the hazard; and
- (b) be of a strength and rigidity to withstand the foreseeable impact of people; and
- (c) restrict the access of young children to the pool and the immediate pool surrounds; and
- (d) have any gates and doors fitted with latching devices not readily operated by young children, and constructed to automatically close and latch.

Application:

P2.5.3 only applies to a *swimming pool* with a depth of water more than 300 mm.

STATE AND TERRITORY VARIATIONS

1. **P2.5.3 does not apply in New South Wales.**

Note: Restriction of access to *swimming pools* in New South Wales is regulated under the Swimming Pools Act 1992.

2. **P2.5.3 does not apply in the Northern Territory.**

3. **P2.5.3 does not apply in Queensland.**

Note: Restriction of access to *swimming pools* in Queensland is regulated under the Building Act 1975.

4. **P2.5.3 does not apply in Western Australia.**

Note: Restriction of access to *swimming pools* in Western Australia is regulated under the Local Government (Miscellaneous Provisions) Act 1960 and the Building Regulations 1989 as amended.

PART 2.6 ENERGY EFFICIENCY

STATE AND TERRITORY VARIATIONS

1. **Part 2.6 does not apply in the Australian Capital Territory**

Note: The Australian Capital Territory Additions contain energy efficiency measures that apply in the Australian Capital Territory.

2. **Part 2.6 does not apply in New South Wales**

Note: The New South Wales Additions contain energy efficiency measures that apply in New South Wales.

3. **O2.6, F2.6 and P2.6.1 apply in Victoria. The remainder of Part 2.6 does not apply in Victoria**

Note: The Victoria Additions contain energy efficiency measures that apply in Victoria.

OBJECTIVE

O2.6

The *Objective* is to reduce greenhouse gas emissions by efficiently using energy.

FUNCTIONAL STATEMENT

F2.6

To reduce greenhouse gas emissions, a building, including its *domestic services*, is to be capable of efficiently using energy.

PERFORMANCE REQUIREMENT

P2.6.1 Building

A building must have, to the degree necessary, a level of thermal performance to facilitate the efficient use of energy for artificial heating and cooling appropriate to—

- (a) the function and use of the building; and
- (b) the internal environment; and
- (c) the geographic location of the building; and

- (d) the effects of nearby permanent features such as topography, structures and buildings; and
- (e) solar radiation being—
 - (i) utilised for heating; and
 - (ii) controlled to minimise energy for cooling; and
- (f) the sealing of the building *envelope* against air leakage; and
- (g) the utilisation of air movement to assist cooling.

Explanatory information:

The term “facilitate” is used in P2.6.1 to highlight the need to consider the installation of energy efficiency measures in a building where there is a likelihood that an artificial heating or cooling system will be installed in the building irrespective of the initial design.

In P2.6.1(d) the term “permanent” is used to describe features that will have a long term impact on the building and includes natural features of the landscape, such as mountains and escarpments, while permanent man made features would be buildings likely to be in place for a long period of time.

P2.6.2 Services

A building’s *domestic services*, including any associated distribution system and components must have features that, to the degree necessary, facilitate the efficient use of energy appropriate to—

- (a) the *domestic service* and its usage; and
- (b) the geographic location of the building; and
- (c) the location of the *domestic service*; and
- (d) the energy source.

VERIFICATION METHODS

V2.6 Definitions

The following definitions are used in this Part:

Cooling load means the calculated amount of energy removed from the cooled spaces of the building annually by artificial means to maintain the desired temperatures in those spaces.

Heating load means the calculated amount of energy delivered to the heated spaces of the building annually by artificial means to maintain the desired temperatures in those spaces.

Reference building means a hypothetical building that is used to determine the maximum allowable *heating load* and *cooling load* for the proposed building.

Thermal calculation method means a calculation method that identifies—

- (a) a *heating load*; or
 - (b) a *cooling load*; or
 - (c) a *heating load* and a *cooling load* (annual energy load),
- based on the sum of hourly loads or an equivalent approach.

Explanatory information:

The protocol for thermal calculation methods used to determine the energy rating of houses is detailed in the ABCB Protocol for House Energy Rating Software. At the date of publication, version 3.2 of BERS, version 3.5 of FirstRate and version 2.32 of NatHERS were considered to comply with this Protocol.

V2.6.1 Application of this Part

The *Verification Methods* in this Part only apply to—

- (a) a Class 1 building; and
- (b) an enclosed Class 10a building attached to a Class 1 building.

Explanatory information:

The *Verification Methods* in this Part are intended to apply to whole Class 1 buildings and to whole Class 1 buildings that incorporate attached and enclosed Class 10a parts, such as attached garages. The *Verification Methods* are not intended to apply to detached garages or to open carports.

V2.6.2 Alternative Verification Methods

Compliance with [P2.6.1](#) is achieved by verifying the building in accordance with [V2.6.2.1](#) or [V2.6.2.2](#).

STATE AND TERRITORY VARIATIONS

In Northern Territory V2.6.2 is replaced with the following:

V2.6.2 Verification method

Compliance with P2.6.1 is achieved by verifying the building in accordance with V2.6.2.2.

Explanatory information:

The *thermal calculation method* in [V2.6.2.1](#) is intended to be used with a procedure for the energy rating of houses, while the *thermal calculation method* in [V2.6.2.2](#) may be used with a broad range of Australian and international energy analysis software.

V2.6.2.1 Verification using stated value

- (a) A building must have an annual energy load, determined using a *thermal calculation method*, which is equal to or less than—
 - (i) in *climate zones* 1 to 3—

- (A) the annual energy load equivalent to a 3.5 star house energy rating determined in accordance with the ABCB Protocol for House Energy Rating Software; or
- (B) the annual energy load value listed in [Table V2.6.1](#) for—
 - (aa) the location where the building is to be constructed; or
 - (bb) the nearest location with similar climatic conditions, if the location is not listed in [Table V2.6.1](#); and
- (ii) in *climate zones* 4 to 8, the annual energy load equivalent to a 4 star house energy rating.
- (b) In *climate zones* 1 to 3, the maximum annual energy load value may be increased by 20 MJ/m².annum if—
 - (i) a solar hot water supply system having a minimum of 2 solar collectors and a storage capacity of not less than 270 litres is installed to serve the building; or
 - (ii) a gas or electric heat pump hot water system is installed to serve the building.

STATE AND TERRITORY VARIATIONS

1. **In South Australia V2.6.2.1(a)(ii) is replaced with the following:**
 - (ii) in *climate zones* 4, 5 and 6, the annual energy load equivalent to a 4 star house energy rating when the building is assessed with the Nationwide House Energy Rating Scheme (NatHERS version 2.32) or FirstRate house rating software (version 3.5).
2. **V2.6.2.1(b) does not apply in Queensland.**

Explanatory information:

The effects of building fixtures such as carpets, heavy curtains, reflective *window* coverings and the effects of adjoining buildings, topography and the like may be considered in certain situations provided the fixture or feature has a degree of permanency.

Table V2.6.1 MAXIMUM ANNUAL ENERGY LOAD FOR SPECIFIC LOCATIONS (MJ/m².annum)

Location	Load	Location	Load	Location	Load	Location	Load
New South Wales							
Byron Bay	150	Grafton	153	Port Macquarie	190		
Coffs Harbour	153	Lismore	213				
Queensland							
Birdsville	240	Cooktown	450	Mackay	130	Roma	180
Brisbane east	105	Cunnamulla	180	Maryborough	105	Torrens Creek	325
Brisbane west	120	Longreach	300	Mount Isa	325	Townsville	225

Location	Load	Location	Load	Location	Load	Location	Load
Bundaberg	105	Gladstone	130	Normanton	450	Warwick	135
Cairns	225	Labrador	105	Rockhampton	130	Weipa	450
Western Australia							
Broome	405	Derby	405	Halls Creek	413	Port Hedland	405
Carnarvon	183	Shark Bay	183	Karratha	405	Wyndham	405

Explanatory information:

The values in [Table V2.6.1](#) are the theoretical maximum energy loads in *climate zones* 1 to 3 for a house with energy efficiency measures considered appropriate for the location by the respective jurisdiction. They are expressed in terms of values in the Nationwide House Energy Rating Scheme which contains inherent assumptions such as occupancy hours, the heat generated by appliances and how blinds are operated. These values do not necessarily reflect how all people use a building in all circumstances but that they are appropriate as a basis of comparison with the values in [Table V2.6.1](#) as they have been determined using the same assumptions.

Verification using stated values may be available in the Northern Territory when the procedure for energy rating of a house allows for a house that is often operated in a free-running mode.

V2.6.2.2 Verification using a reference building

- (a) A proposed building must, when compared with a *reference building*, have—
 - (i) in *climate zones* 1 and 2, a *cooling load* equal to or less than that of the *reference building*; or
 - (ii) in *climate zones* 7 and 8, a *heating load* equal to or less than that of the *reference building*; or
 - (iii) in *climate zones* 3, 4, 5 and 6, a *heating load* and a *cooling load* equal to or less than that of the *reference building*.
- (b) The *heating load* and *cooling load* for the proposed building and the *reference building* must be determined—
 - (i) using the same *thermal calculation method*; and
 - (ii) using the same location specific data, including that of climate and topography appropriate to the location where the proposed building is to be constructed.
- (c) The *thermal calculation method* used must be capable of assessing the *heating load* and *cooling load* by modelling—
 - (i) the building *fabric*; and
 - (ii) *glazing* and shading; and
 - (iii) air infiltration and ventilation; and
 - (iv) the function and use of the building including zoning, hours of occupation, hours of heating and cooling availability and internal heat gains; and

- (v) space temperature settings in the range 20°C to 21°C for heating and 25°C to 28°C for cooling; and
 - (vi) relevant built-environment and topographical features; and
 - (vii) the sensible heat component of the *cooling load* and *heating load*.
- (d) Climatic data employed in the *thermal calculation method* must be based on hourly recorded values and be representative of a typical year for the proposed location.
- (e) The *reference building* must be modelled using the requirements described in [Table V2.6.2](#).

Explanatory information:

1. In (c)(iv), the number of hours per day for which heating and cooling is available would be expected to lie between 8 and 17, with values outside this range unlikely in other than exceptional circumstances.
2. Suitable climatic data including dry-bulb temperature, direct and diffuse solar radiation, wind speed, wind direction and cloud cover can be obtained from the Australian national climate database.
3. The requirements in [Table V2.6.2](#) provide inputs for the modelling of a hypothetical *reference building* in order to determine the acceptable energy loads. The loads from the modelled *reference building* is then used to establish the maximum loads for the proposed building.

Table V2.6.2 REFERENCE BUILDING MODELLING REQUIREMENTS

Item	Description	Minimum criteria to be modelled	
1	Impact of adjoining structures and features	Same as the proposed building	
2	Soil conditions	Same as the proposed building	
3	Orientation	Same as the proposed building	
4	Floor plan	Same as the proposed building	
5	Number of storeys	Same as the proposed building	
6	Ceilings	2.4 m high horizontal ceiling	
7	Solar absorptance of external surfaces	Same as the proposed building	
8	Building sealing	In accordance with 3.12.3 for the relevant <i>climate zone</i>	
9	Air movement	In accordance with 3.12.4 for the relevant <i>climate zone</i>	
10	Total <i>glazing</i> area for the building (for use in item 11)	The area in Table 3.12.2.1 for—	
		(a)	3 mm single clear glass in a standard aluminium frame; and
		(b)	<i>glazing</i> that has no shading

Item	Description	Minimum criteria to be modelled	
11	<i>Glazing area for each external wall</i>	The area of <i>glazing</i> determined in item 10 is distributed—	
		(a)	to each <i>external wall</i> of the reference building that is suitable for the installation of a window; and
		(b)	in the same ratio to the total <i>glazing area</i> as the area of the wall to the total wall area available for <i>glazing</i>
12	<i>Glazing coverings</i>	Holland blinds operated in a comparable manner as, and using the same criteria applied to, the <i>glazing coverings</i> in the proposed building	
13	Roof	Pitched roof (18 degrees)	
14	Roof cladding	Same as the proposed building	
15	Roof insulation	In accordance with Table 3.12.1.1 for the relevant <i>climate zone</i>	
16	<i>Roof lights</i>	Any <i>roof light</i> in the proposed building provided the <i>roof light</i> is the only means of complying with 3.8.4.2	
17	<i>External walls</i>	Brick veneer with 110 mm thick clay masonry	
18	<i>Separating walls</i>	Same as the proposed building	
19	Wall insulation	In accordance with Table 3.12.1.3 for the relevant <i>climate zone</i>	
20	External non-glazed doors	Same as the proposed building	
21	Internal walls	70 mm wide timber frame complying with 3.4.3	
22	Internal linings	10 mm internal plaster lining	
23	Ground floor	Concrete slab-on-ground	
24	Intermediate floors	Same as the proposed building	
25	Floor coverings	Same as the proposed building	
26	Internal zones	Same as the proposed building	
27	Internal heat gains including people and appliances	Same as the proposed building	

Explanatory information:

The distribution of *glazing* in Item 11(a) will depend on whether it is possible to have *glazing* in all walls. For example, it would not be possible if the house shares a *separating wall* with an adjoining building. However, the reference building would have a proportion of *glazing* on all walls that are permitted to have *glazing* even though *glazing* may not be on all walls of the proposed building.

ACCEPTABLE CONSTRUCTION

Introduction

The scope of these provisions

Suitability of Alternate Solutions

The use of maps

Consultation with appropriate authorities

Layout of Parts 3.1 - 3.12

How to use the requirements of each Part

SECTION 3 CONTENTS

SECTION 3 ACCEPTABLE CONSTRUCTION

3.0 How to Use Section

Introduction
The scope of these provisions
Suitability of Alternative Solutions
The use of maps
Consultation with appropriate authorities
Layout of Parts 3.1 to 3.12
How to use the requirements of each Part

PART 3.1 SITE PREPARATION

Explanatory Information

3.1.1 Earthworks

3.1.1.0 Application
3.1.1.1 Earthworks
3.1.1.2 Excavation adjacent to vacant adjoining property
3.1.1.3 Excavation adjacent to existing buildings
3.1.1.4 Fill

3.1.2 Drainage

3.1.2.0 Acceptable construction manual
3.1.2.1 Application
3.1.2.2 Drainage requirements
3.1.2.3 Surface water drainage
3.1.2.4 Subsoil drainage
3.1.2.5 Stormwater drainage

3.1.3 Termite Risk Management

3.1 Definitions
3.1.3 Application
3.1.3.0 Acceptable construction manual
3.1.3.1 Application
3.1.3.2 Installation of termite barriers
3.1.3.3 Barriers for concrete slab-on-ground
3.1.3.4 Barriers for suspended floors
3.1.3.5 Attachments to buildings

PART 3.2 FOOTINGS AND SLABS

Explanatory Information

3.2 Footings and Slabs

- 3.2 Definitions
- 3.2.0 Acceptable construction manual
- 3.2.1 Application

3.2.2 Preparation

- 3.2.2.1 Excavation for footings
- 3.2.2.2 Filling under concrete slabs
- 3.2.2.3 Foundations for footings and slabs
- 3.2.2.4 Slab edge support on sloping sites
- 3.2.2.5 Stepped footings
- 3.2.2.6 Vapour barriers
- 3.2.2.7 Edge rebates

3.2.3 Concrete and Reinforcing

- 3.2.3.1 Concrete
- 3.2.3.2 Steel reinforcement

3.2.4 Site Classification

- 3.2.4.1 Site classification

3.2.5 Footing and Slab Construction

- 3.2.5.1 Footing and slab construction
- 3.2.5.2 Footings and slabs to extensions to existing buildings
- 3.2.5.3 Shrinkage control
- 3.2.5.4 Minimum edge beam dimensions
- 3.2.5.5 Footings for fireplaces on Class A and S sites
- 3.2.5.6 Stump footing details

PART 3.3 MASONRY

3.3 Definitions

3.3.1 Unreinforced Masonry

- 3.3.1.0 Acceptable construction manual
- 3.3.1.1 Application
- 3.3.1.2 External walls
- 3.3.1.3 Internal walls
- 3.3.1.4 Isolated piers
- 3.3.1.5 Masonry units
- 3.3.1.6 Mortar mixes
- 3.3.1.7 Mortar joints
- 3.3.1.8 Vertical articulation joints
- 3.3.1.9 Sub-floor ventilation
- 3.3.1.10 Shrinkage allowance for timber framing

3.3.2 Reinforced Masonry

- 3.3.2.0 Acceptable construction manual
- 3.3.2.1 Application
- 3.3.2.2 External wall construction

3.3.3 Masonry Accessories

- 3.3.3.0 Acceptable construction manual
- 3.3.3.1 Application
- 3.3.3.2 Wall ties
- 3.3.3.3 Fixing straps and tie down systems
- 3.3.3.4 Lintels

3.3.4 Weatherproofing of Masonry

- 3.3.4 Application of this Part
- 3.3.4.0 Acceptable construction manual
- 3.3.4.1 Application
- 3.3.4.2 Width of cavity
- 3.3.4.3 Cavity ventilation and drainage
- 3.3.4.4 Damp-proof courses - materials
- 3.3.4.5 Damp-proof courses - installation
- 3.3.4.6 Flashings
- 3.3.4.7 Location of flashings
- 3.3.4.8 Flashings at the base of cavity walls
- 3.3.4.9 Sill and head flashing
- 3.3.4.10 Flashings at a roof abutting a wall
- 3.3.4.11 Chimney flashings
- 3.3.4.12 Weatherproofing for single skin masonry walls

3.3.5 Earthwall Construction

- 3.3.5 Definitions
- 3.3.5.0 Acceptable construction manual
- 3.3.5.1 Application
- 3.3.5.2 General construction
- 3.3.5.3 Minimum thickness of walls
- 3.3.5.4 Weatherproofing

PART 3.4 FRAMING

3.4.0 Explanation of Terms

- 3.4.0.1 Explanation of terms

3.4.1 Sub-Floor Ventilation

- 3.4.1.1 Application
- 3.4.1.2 Sub-floor ventilation

3.4.2 Steel Framing

- 3.4.2.0 Acceptable construction manual
- 3.4.2.1 Application
- 3.4.2.2 General
- 3.4.2.3 Steel floor framing
- 3.4.2.4 * * *
- 3.4.2.5 * * *
- 3.4.2.6 Installation of services

3.4.3 Timber Framing

- 3.4.3.0 Acceptable construction manual
- 3.4.3.1 * * *

- 3.4.3.2 * * *
- 3.4.3.3 * * *
- 3.4.3.4 * * *
- 3.4.3.5 * * *
- 3.4.3.6 * * *
- 3.4.3.7 * * *
- 3.4.3.8 * * *

3.4.4 Structural Steel Members

- 3.4.4 Explanation of Terms
- 3.4.4.0 Acceptable construction manuals
- 3.4.4.1 Application
- 3.4.4.2 Structural steel members
- 3.4.4.3 Columns
- 3.4.4.4 Corrosion protection

PART 3.5 ROOF AND WALL CLADDING

Explanatory Information

3.5.1 Roof cladding

- 3.5.1.0 Acceptable construction manuals
- 3.5.1.1 Application
- 3.5.1.2 Roof tiling
- 3.5.1.3 Metal sheet roofing

3.5.2 Gutters and downpipes

- 3.5.2.0 Acceptable construction manual
- 3.5.2.1 Application
- 3.5.2.2 Materials
- 3.5.2.3 Selection of guttering
- 3.5.2.4 Installation of gutters
- 3.5.2.5 Downpipes—size and installation

3.5.3 Wall Cladding

- 3.5.3.1 Application
- 3.5.3.2 Timber weatherboard cladding
- 3.5.3.3 Fibre cement planks and weatherboard cladding
- 3.5.3.4 Sheet wall cladding
- 3.5.3.5 Eaves and soffit linings
- 3.5.3.6 Flashings to wall openings

PART 3.6 GLAZING

3.6 Glazing

- 3.6 Definitions
- 3.6.0 Acceptable construction manuals
- 3.6.1 Application
- 3.6.2 Glazing sizes and installation
- 3.6.3 Perimeter framed glazing
- 3.6.4 Human impact safety requirements

- 3.6.5 Doors
- 3.6.6 Side panels
- 3.6.7 Full height framed glazed panels
- 3.6.8 Glazed panels, other than doors or side panels, on the perimeter of rooms
- 3.6.9 Shower doors, shower screens and bath enclosures

PART 3.7 FIRE SAFETY

3.7.1 Fire separation

- 3.7.1.1 Application
- 3.7.1.2 General concession—non-combustible materials
- 3.7.1.3 External walls of Class 1 buildings
- 3.7.1.4 Measurement of distances
- 3.7.1.5 Construction of external walls
- 3.7.1.6 Class 10a buildings
- 3.7.1.7 Allowable encroachments
- 3.7.1.8 Separating walls
- 3.7.1.9 Fire hazard properties
- 3.7.1.10 Roof lights

3.7.2 Smoke alarms

- 3.7.2.1 Application
- 3.7.2.2 Requirements for smoke alarms
- 3.7.2.3 Location—Class 1a buildings
- 3.7.2.4 Location—Class 1b buildings
- 3.7.2.5 Lighting to assist evacuation—Class 1b buildings

3.7.3 Heating appliances

- 3.7.3.0 Acceptable construction manuals
- 3.7.3.1 Application
- 3.7.3.2 Open fireplace construction
- 3.7.3.3 Chimney construction
- 3.7.3.4 Installation of insert fireplaces and flues
- 3.7.3.5 Installation of free standing heating appliances

3.7.4 Bushfire areas

- 3.7.4.0 Acceptable construction manuals
- 3.7.4.1 Application
- 3.7.4.2 Categories of bushfire attack
- 3.7.4.3 Construction requirements

3.7.5 Alpine areas

- 3.7.5.1 Application
- 3.7.5.2 External doorways
- 3.7.5.3 External ramps
- 3.7.5.4 Discharge of external doorways providing a means of egress
- 3.7.5.5 External trafficable structures

PART 3.8 HEALTH AND AMENITY

3.8.1 Wet areas

- 3.8.1 Definitions
- 3.8.1.0 Acceptable construction manual
- 3.8.1.1 * * * * *

3.8.2 Room heights

- 3.8.2.1 Application
- 3.8.2.2 Ceiling heights

3.8.3 Facilities

- 3.8.3.1 Application
- 3.8.3.2 Required facilities
- 3.8.3.3 Construction of sanitary compartments

3.8.4 Light

- 3.8.4.1 Application
- 3.8.4.2 Natural lighting
- 3.8.4.3 Artificial lighting

3.8.5 Ventilation

- 3.8.5.0 Acceptable construction manual
- 3.8.5.1 Application
- 3.8.5.2 Ventilation requirements
- 3.8.5.3 Location of sanitary compartments

3.8.6 Sound insulation

- 3.8.6.1 Application
- 3.8.6.2 Sound insulation requirements
- 3.8.6.3 General installation requirements for walls
- 3.8.6.4 Services

PART 3.9 SAFE MOVEMENT AND ACCESS

3.9.1 Stair construction

- 3.9.1 Definitions
- 3.9.1.1 Application
- 3.9.1.2 General requirements
- 3.9.1.3 Stair construction
- 3.9.1.4 Riser and going dimensions
- 3.9.1.5 Threshold

3.9.2 Balustrades

- 3.9.2.1 Application
- 3.9.2.2 When balustrades or other barriers are required
- 3.9.2.3 Balustrades or other barrier construction

3.9.3 Swimming pool access

- 3.9.3.0 Acceptable construction manual
- 3.9.3.1 Application
- 3.9.3.2 Safety fencing location
- 3.9.3.3 Safety fencing construction

3.9.3.4 Gates and fittings

PART 3.10 ADDITIONAL CONSTRUCTION REQUIREMENTS

Explanatory Information

3.10.1 High Wind Areas

3.10.1.0 Acceptable construction manual

3.10.2 Earthquake Areas

3.10.2 Definitions

3.10.2.0 Acceptable construction manuals

3.10.2.1 Application

3.10.2.2 Construction requirements

3.10.2.3 Construction for areas with an acceleration coefficient of 0.12 or more but less than 0.15

3.10.2.4 Construction for areas with an acceleration coefficient of 0.15 or greater

PART 3.11 STRUCTURAL DESIGN MANUALS

Explanatory Information

3.11 Structural design manuals

3.11.1 Application

3.11.2 Resistance to actions

3.11.3 Determination of individual actions

3.11.4 Acceptable structural design manuals

3.11.5 Loading requirements

3.11.6 Determination of structural resistance of materials and forms of construction

PART 3.12 ENERGY EFFICIENCY

3.12 Energy efficiency

3.12 Definitions

3.12.0 Application of Part 3.12

3.12.1 Building fabric

3.12.1 Application

3.12.1.1 Building fabric insulation

3.12.1.2 Roofs

3.12.1.3 Roof lights

3.12.1.4 External walls

3.12.1.5 Floors

3.12.1.6 Attached Class 10a buildings

3.12.2 External Glazing

3.12.2 Application

3.12.2.1 External glazing

3.12.2.2 Shading

3.12.3 Building Sealing

- 3.12.3 Application
- 3.12.3.0 A. Acceptable construction manual
- 3.12.3.1 Chimneys and flues
- 3.12.3.2 Roof lights
- 3.12.3.3 External windows and doors
- 3.12.3.4 Exhaust fans
- 3.12.3.5 Construction of roofs, walls and floors

3.12.4 Air Movement

- 3.12.4 Application
- 3.12.4.1 Air movement
- 3.12.4.2 Ventilation openings
- 3.12.4.3 Ceiling fans and evaporative coolers

3.12.5 Services

- 3.12.5 Application
- 3.12.5.0 Acceptable construction manual
- 3.12.5.1 Insulation of services
- 3.12.5.2 Central heating water piping
- 3.12.5.3 Heating and cooling ductwork

PART 3.0 HOW TO USE SECTION 3

Explanatory information:

This is a non mandatory guide on how to use Section 3 of the *Housing Provisions*.

3.1 Introduction

Section 3, Parts 3.1 to 3.12 are *Deemed.to.Satisfy Provisions* that are considered to be acceptable forms of construction that meet the legislative requirements for complying with the *Housing Provisions* (ie they comply with the *Performance Requirements* listed in Section 2 of the *Housing Provisions*).

There is no obligation to adopt any particular option contained in Section 3 of the *Housing Provisions*, if it is preferred to meet the *Performance Requirement* in some other way.

However, if one of the options described in Section 3 is not complied with, then the *appropriate authority* must be satisfied that the *Performance Requirements* have been met.

3.2 The scope of these provisions

The *Deemed.to.Satisfy Provisions* (described as “acceptable construction practice” or “acceptable construction manuals”) are indicative of some of the most common forms of national construction practice.

However, it should be noted that some of these options described as “acceptable construction practice” may have very specific limitations and accordingly will not be suitable for all applications. Generally these limitations relate to climatic (*design wind speed*), geographical and topographical conditions and building geometry.

If the acceptable construction practice option is not suitable for the proposed construction or *site* conditions, an alternative approach may be found in one of the acceptable construction manuals listed at the start of each Part. Similarly, if a particular building element or component *required* to comply with the *Housing Provisions* is not contained in the acceptable construction practice, reference will need to be made to the appropriate acceptable construction manual or Part 3.11.

3.3 Suitability of Alternative Solutions

The options described in Section 3 are typical examples. They are certainly not the only means available of complying with the *Housing Provisions*. The performance nature of this document provides flexibility and allows the use of alternative construction methods even though they may not be specifically described in an acceptable construction manual or as acceptable construction practice.

Alternative Solutions may be used provided they comply with the *Performance Requirements* listed in Section 2 (for further explanation see Part 1.0).

3.4 The use of maps

Maps have been used throughout Section 3 to indicate areas where particular requirements apply. These maps are indicative and some variation in conditions will apply, especially on the border of marked areas.

It is recommended that the *appropriate authority* be consulted and in most cases they may be able to identify what conditions apply in such areas at the early stage of building design.

3.5 Consultation with appropriate authorities

When building in certain locations there may be local conditions that may limit the type of construction that can be used. This is particularly important with *design wind speed* classifications and soil types.

Appropriate authorities have a wide range of experience and information on the geographical and topographical conditions found in their area of responsibility, and should be consulted during the initial design stage.

3.6 Layout of Parts 3.1 to 3.12

Parts 3.1 to 3.12 of the *Housing Provisions* are organised in a manner that follows the logical construction sequence of a building. The following chart outlines some of the more frequently used details and where it is located in this document.

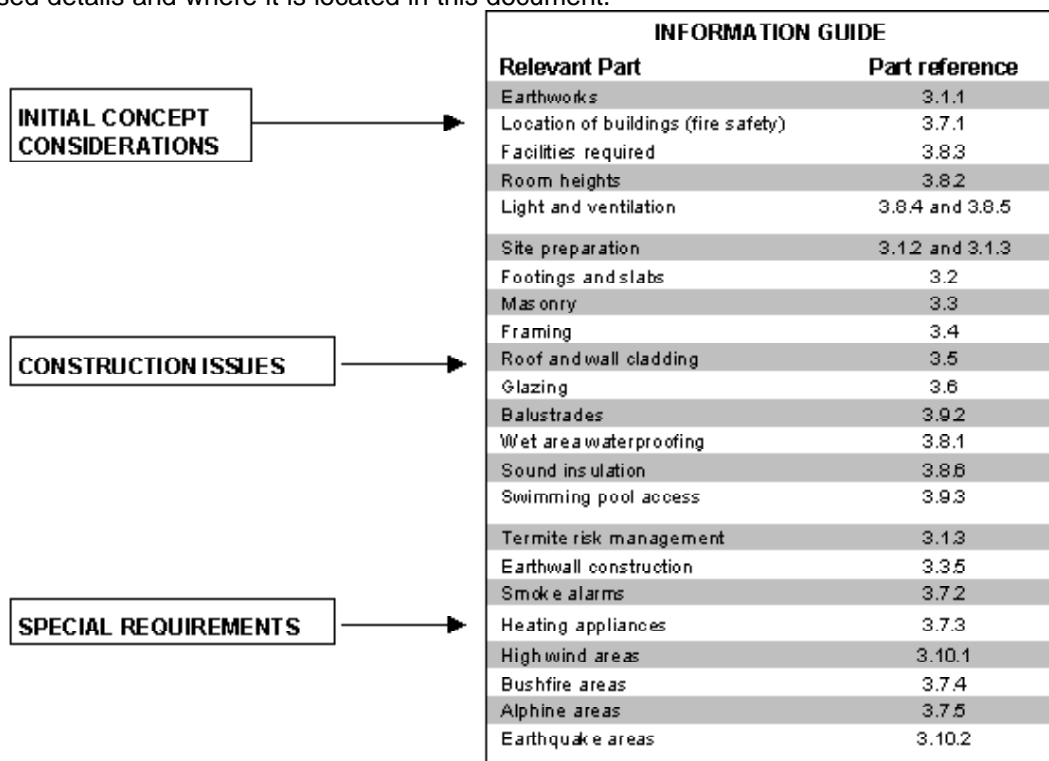

3.7 How to use the requirements of each Part

The following is an example page layout from Part 3.2. This diagram explains the concepts behind typical clauses contained throughout Parts 3.1 to 3.12.

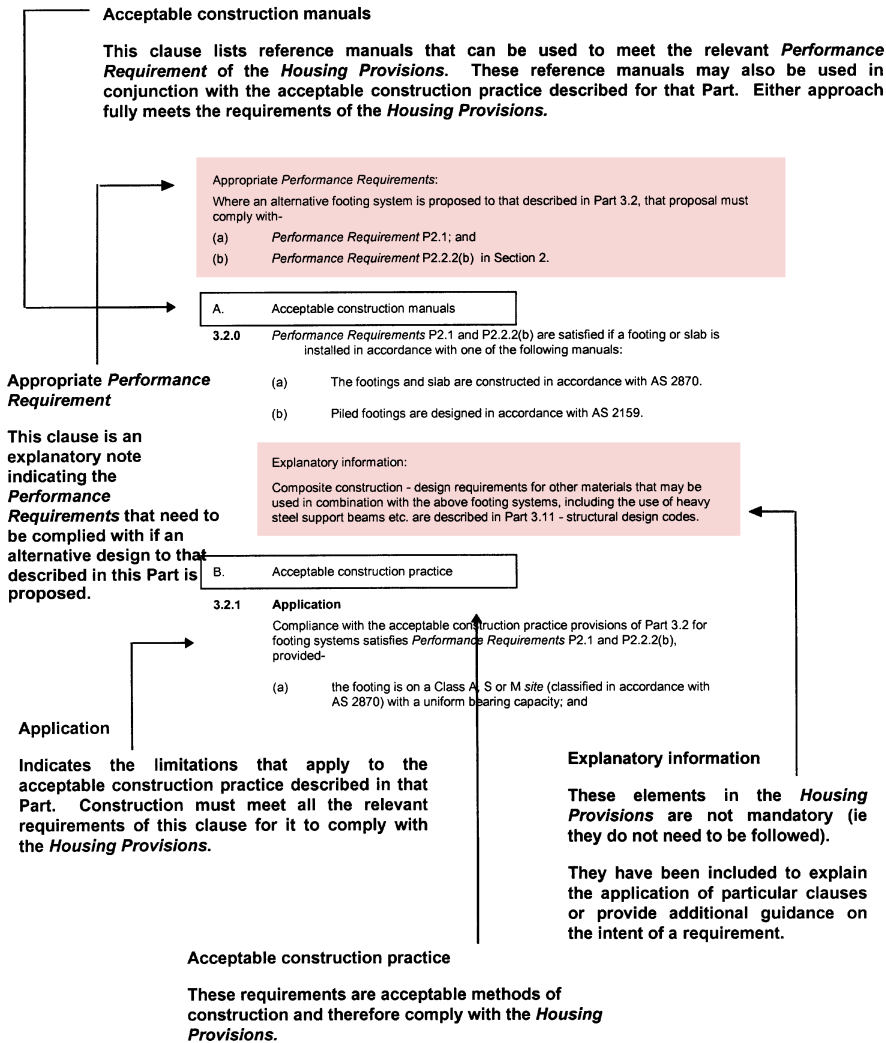

PART **3.1**

SITE PREPARATION

- 3.1.1 Earthworks
- 3.1.2 Drainage
- 3.1.3 Termite risk management

PART 3.1 CONTENTS

PART 3.1 SITE PREPARATION

Explanatory Information

3.1.1 Earthworks

- 3.1.1.0 Application
- 3.1.1.1 Earthworks
- 3.1.1.2 Excavation adjacent to vacant adjoining property
- 3.1.1.3 Excavation adjacent to existing buildings
- 3.1.1.4 Fill

3.1.2 Drainage

- 3.1.2.0 Acceptable construction manual
- 3.1.2.1 Application
- 3.1.2.2 Drainage requirements
- 3.1.2.3 Surface water drainage
- 3.1.2.4 Subsoil drainage
- 3.1.2.5 Stormwater drainage

3.1.3 Termite Risk Management

- 3.1.3 Definitions
- 3.1.3 Application
- 3.1.3.0 Acceptable construction manual
- 3.1.3.1 Application
- 3.1.3.2 Installation of termite barriers
- 3.1.3.3 Barriers for concrete slab-on-ground
- 3.1.3.4 Barriers for suspended floors
- 3.1.3.5 Attachments to buildings

PART 3.1 EXPLANATORY INFORMATION

Explanatory information:

These provisions relate to general *site* preparation for footings, services, drainage and installation of termite barriers to assist in termite management. It should be noted that other construction methods may be used to achieve the same results as specified in this Part provided they comply with the appropriate *Performance Requirement*.

PART 3.1.1 EARTHWORKS

Appropriate Performance Requirements:

Where an alternative approach to earthworks is proposed as an *Alternative Solution* to that described in **Part 3.1.1**, that proposal must comply with—

- (a) *Performance Requirement P2.1*: and
- (b) the relevant *Performance Requirements* determined in accordance with **1.0.10**.

STATE AND TERRITORY VARIATIONS

Except for **Table 3.1.1.1** as referenced by **Figures 3.1.2.1** and **3.1.2.2** and except for **Clause 3.1.1.0 (b)** for determination of a normal site as referenced by **Clause 3.2.1**, **Part 3.1.1** does not apply in New South Wales.

Note: In New South Wales the consent authority can determine to place controls on siteworks associated with the erection of a building, by imposing conditions when it grants development consent. These controls can include the safeguarding of excavations and backfilling, provision of retaining walls to prevent soil movement, and support for neighbouring buildings. Information addressing siteworks can be found in the Department of Infrastructure Planning and Natural Resources' Act and Regulation note "Health, safety and amenity during construction".

Acceptable construction practice

3.1.1.0 Application

Compliance with this Part satisfies *Performance Requirement P2.1* for earthworks provided:

- (a) The work is undertaken in normal *site* conditions.
- (b) For the purposes of this Part, normal *site* conditions are defined by the following parameters—
 - (i) a *site* that is classified as A, S, M, H or E in accordance with **Part 3.2**; and
 - (ii) moisture conditions on *site* are as a result of seasonal and climatic changes; and
 - (iii) the *site* is not subject to unusual moisture conditions caused by drains, dams, channels, ponds or tanks which are maintained or removed from the *site*; and
 - (iv) large trees have not been recently removed from the *site*; and
 - (v) soil moisture conditions have not been significantly modified by the removal of buildings or other structures; and
 - (vi) drainage on the allotment is maintained.

Explanatory information:

The provisions described in **Part 3.1.1** will enable earthworks to be carried out safely and avoid potential damage to adjoining structures and property through the soil collapsing or subsiding during building works. Exceptional *site* conditions (including the effects of torrential rain) may need special consideration and additional advice from appropriately qualified people should be considered.

State and Territory legislation may also have requirements that affect the excavation, especially in relation to adjoining property and notification to owners of that property. Advice should be obtained from the *appropriate authority* before commencement of works.

3.1.1.1 Earthworks

Excavation and fill utilising unprotected embankments can be undertaken in accordance with—

- (a) **Table 3.1.1.1** for general earthwork; or
- (b) **3.1.1.2** for excavation adjacent to vacant adjoining property; or
- (c) **3.1.1.3** for excavation adjacent to existing buildings; or
- (d) **3.1.1.4** for fill adjacent to adjoining property.

3.1.1.2 Excavation adjacent to vacant adjoining property

Excavation work, using unprotected embankments, adjacent to another allotment can be undertaken provided—

- (a) there are no buildings or structures on the adjoining allotment within 3 m of the allotment boundary adjacent to the excavation; and
- (b) the excavation commences at the allotment boundary and is within the area defined as being suitable for excavation in **Figure 3.1.1.1**; and
- (c) the slope of the unprotected embankment of the excavation complies with the appropriate soil classification slope described in **Table 3.1.1.1**.

3.1.1.3 Excavation adjacent to existing buildings

Excavation work for footings, drainage trenches or other similar works, adjacent to existing buildings can be undertaken provided—

- (a) the angle to determine the safe area for excavation is taken from the bottom of the shallowest point of the existing footing in accordance with **Figure 3.1.1.2**; and
- (b) the excavation is within the area defined as being suitable for excavation in **Figure 3.1.1.2**; and
- (c) the slope of the unprotected embankment of the excavation complies with the appropriate soil classification described in **Table 3.1.1.1**; and
- (d) for footing excavation adjacent to existing footings—
 - (i) the footing is placed as soon as practicable after exposing the existing footing; and
 - (ii) the existing footing, where on an adjoining property, is completely isolated from the new footing by means of a flexible bond breaker not less than 10 mm thick; and
- (e) the adjoining footing is not left exposed at the completion of works.

Figure 3.1.1.1
EXCAVATION AFFECTING ADJOINING PROPERTY

Note: The angle for line A-A is defined in Table 3.1.1.1.

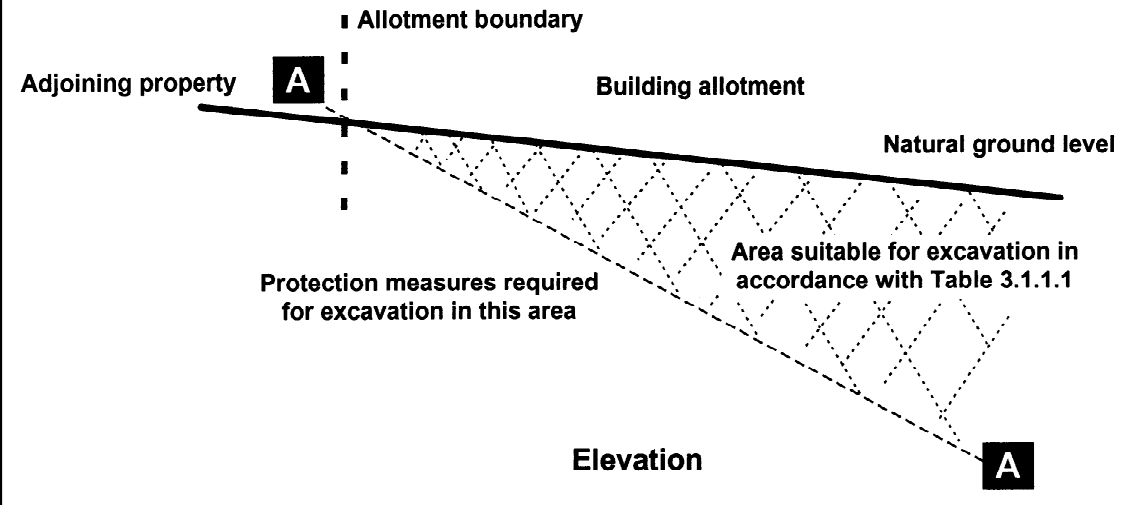
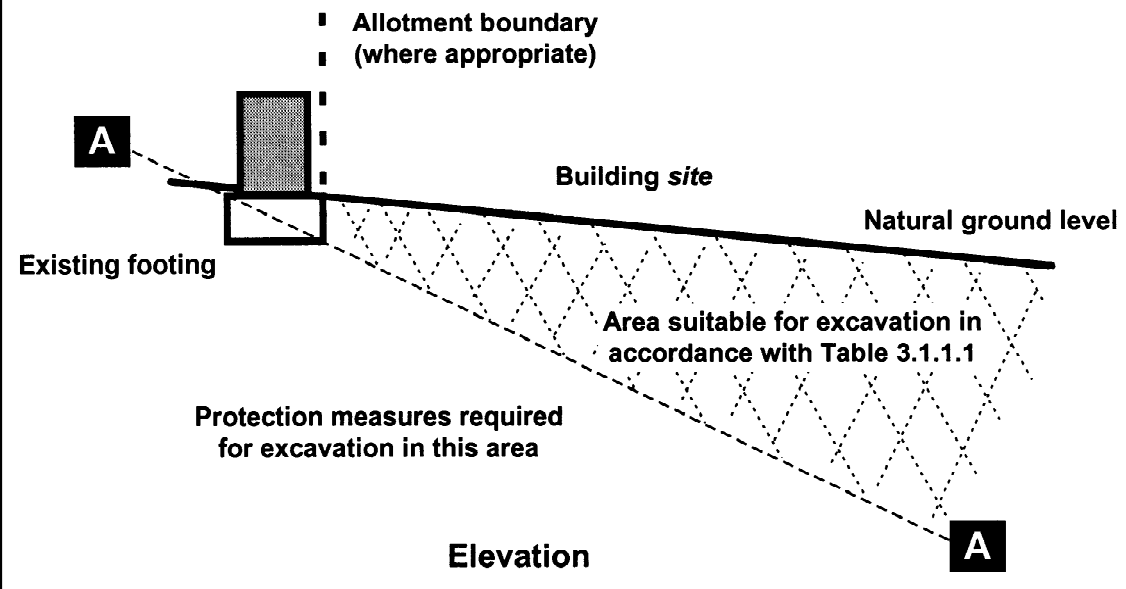

Figure 3.1.1.2
EXCAVATION ADJACENT TO EXISTING BUILDINGS

Note: Line A-A is defined in Table 3.1.1.1 and taken from the bottom of the shallowest point of the existing footing.



3.1.1.4 Fill

Filling works may be carried out provided—

- (a) where the fill is deeper than existing soil level, the gradient of the fill complies with [Table 3.1.1.1](#); and
- (b) where the fill is to be used to support footings or slabs, it is placed and compacted in accordance with [Part 3.2](#).

Table 3.1.1.1			
UNPROTECTED EMBANKMENTS			
Notes:	For the purposes of this Table:		
1.	Retaining walls or other types of soil retaining methods must be installed where—		
	(a)	the slope ratio is more than that described in Table 3.1.1.1 ; or	
	(b)	the soil type is not described in this Table.	
2.	Embankments that are to be left exposed at the end of the construction works must be stabilised by vegetation or similar works to prevent soil erosion.		
<p style="text-align: center;">Elevation</p>			
SOIL TYPE		EMBANKMENT SLOPES H:L	
(*see Part 3.2.4 for material description)		Compacted fill (see Part 3.2)	Cut
Stable rock (A*)		2:3	8:1
Sand (A*)		1:2	1:2
Silt (P*)		1:4	1:4

Table 3.1.1.1				
UNPROTECTED EMBANKMENTS				
Notes:	For the purposes of this Table:			
1.	Retaining walls or other types of soil retaining methods must be installed where—			
	(a)	the slope ratio is more than that described in Table 3.1.1.1; or		
	(b)	the soil type is not described in this Table.		
2.	Embankments that are to be left exposed at the end of the construction works must be stabilised by vegetation or similar works to prevent soil erosion.			
Clay		Firm clay	1:2	1:1
		Soft clay	Not suitable	2:3
Soft soils (P*)			Not suitable	Not suitable

PART 3.1.2 DRAINAGE

Appropriate Performance Requirements:

Where an alternative drainage system is proposed as an *Alternative Solution* to that described in **Part 3.1.2**, that proposal must comply with—

- (a) *Performance Requirement P2.2.1*; and
- (b) the relevant *Performance Requirements* determined in accordance with **1.0.10**.

A. Acceptable construction manual

3.1.2.0

Performance Requirement P2.2.1 is satisfied for drainage if the drainage is designed and constructed in accordance with AS/NZS 3500.3.2—Stormwater drainage, or AS/NZS 3500.5—Domestic installations, Section 5—Stormwater drainage.

B. Acceptable construction practice

3.1.2.1 Application

Compliance with this Part satisfies *Performance Requirement P2.2.1* for drainage of—

- (a) roofs in areas subject to 5 minute duration rainfall intensities of not more than 255 mm per hour over an *average recurrence interval* of 20 years (as per **Table 3.5.2.1**) where a drainage system is *required*; and
- (b) sub-soil areas where excessive soil moisture problems may occur; and
- (c) land adjoining and under buildings,

provided the stormwater drainage system otherwise complies with AS/NZS 3500.3.2 or Section 5 of AS/NZS 3500.5.

Explanatory information:

1. The BCA does not require the installation of drainage systems. Accordingly these requirements need only be applied when these systems are used.
2. Information on the need for drainage systems may be obtained from the *appropriate authority*.
3. The legal discharge point from a building *site* is generally determined by local government authorities.

3.1.2.2 Drainage requirements

Drainage systems must be installed as follows—

- (a) areas adjoining and under buildings—*surface water* drainage in accordance with 3.1.2.3; and
- (b) where *site* conditions exist that create a need for subsoil water to be diverted away from footings, basements, retaining walls etc—sub-soil drainage in accordance with 3.1.2.4; and
- (c) where underground drainage from roof areas is *required* or permitted—underground stormwater drainage in accordance with 3.1.2.5; and
- (d) excavation for drains adjacent to existing footings must be within the area described in Figure 3.1.2.1 as being safe for excavation.

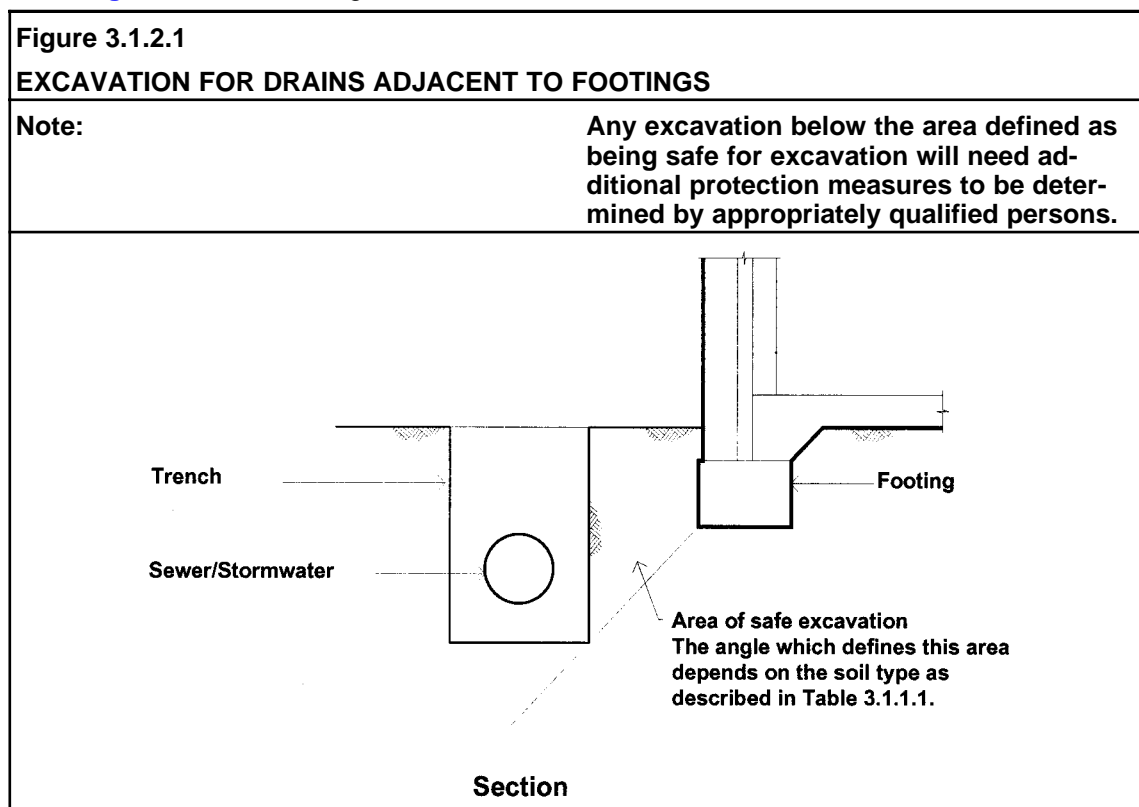

3.1.2.3 Surface water drainage

Surface water must be diverted away from Class 1 buildings as follows:

- (a) Slab-on-ground—finished ground level adjacent to buildings
 The external finished surface surrounding the slab must be drained to move *surface water* away from the building and graded to give a slope of not less than 50 mm over the first 1m from the building (see Figure 3.1.2.2).
- (b) Slab-on-ground—finished slab heights

The height of the slab-on-ground (measured at the slab edge) above external finished surfaces must be not less than—

- (i) 150 mm above finished ground level; or
- (ii) 100 mm above sandy, well-drained areas; or
- (iii) 50 mm above paved or concreted areas that slope away from the building in accordance with (a).

Explanatory information:

The appropriate slab height above finished ground level may vary depending on:

1. The local plumbing requirements; in particular the height of the overflow relief gully relative to drainage fittings and ground level (to work effectively they must be a minimum of 150 mm below the lowest sanitary fixture).
2. The run-off from storms and the local topography.
3. The effect of excavation on a cut and fill *site*.
4. The possibility of flooding.
5. Termite barrier provisions.

- (c) The ground beneath suspended floors must be graded so that the area beneath the building is above the adjacent external finished ground level and *surface water* is prevented from ponding under the building (see **Figure 3.1.2.3**).

STATE AND TERRITORY VARIATIONS

In South Australia 3.1.2.3(a) and (b) are replaced with the following:

Surface water must be directed away from Class 1 buildings as follows:

- (a) Slab-on-ground—finished ground level adjacent to buildings:

The external finished surface surrounding the slab must be drained to move surface water away from the building and graded to give a slope of not less than 25 mm over the first 1 m from the building.

- (b) Slab-on-ground—finished slab heights:

- (i) The height of the finished ground level immediately abutting a slab-on-ground must be not less than—
 - (A) 100 mm below the finished concrete level of the slab; or
 - (B) 80 mm below the finished concrete level of the slab edge rebate.
- (ii) The height of the finished paving level immediately abutting a slab-on-ground must be not less than—
 - (A) 75 mm below the finished concrete level of the slab edge rebate where a perimeter termite barrier is not installed; or
 - (B) where a perimeter termite barrier is installed—
 - (aa) 35 mm below the finished concrete level of the slab; or
 - (bb) 15 mm below the finished concrete level of the slab edge rebate.

**Figure 3.1.2.2
SITE SURFACE DRAINAGE**

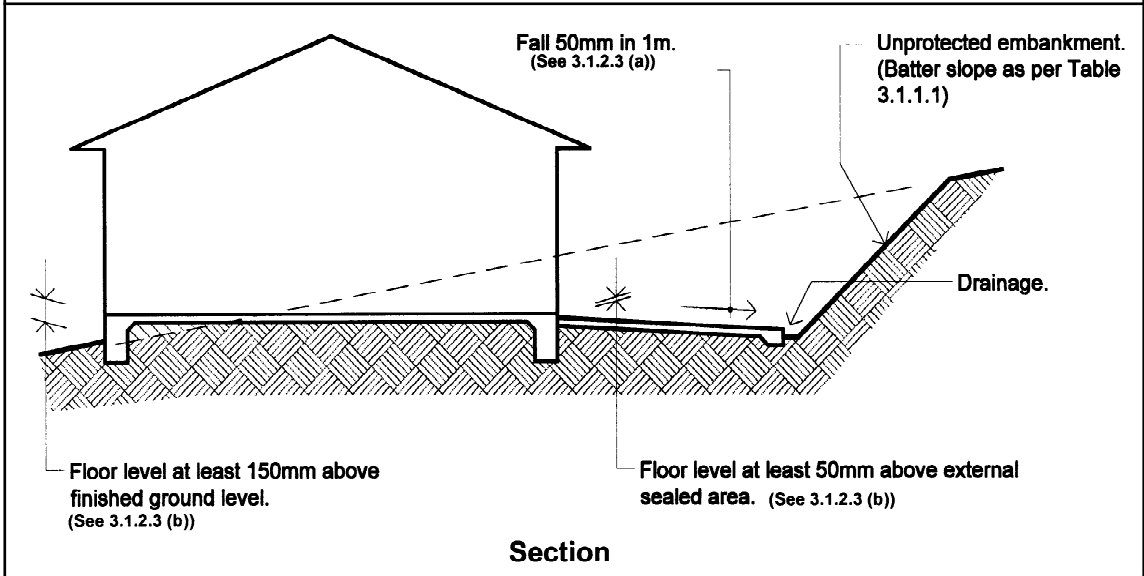

**Figure 3.1.2.3
GRADING OF GROUND UNDER SUSPENDED FLOORS**

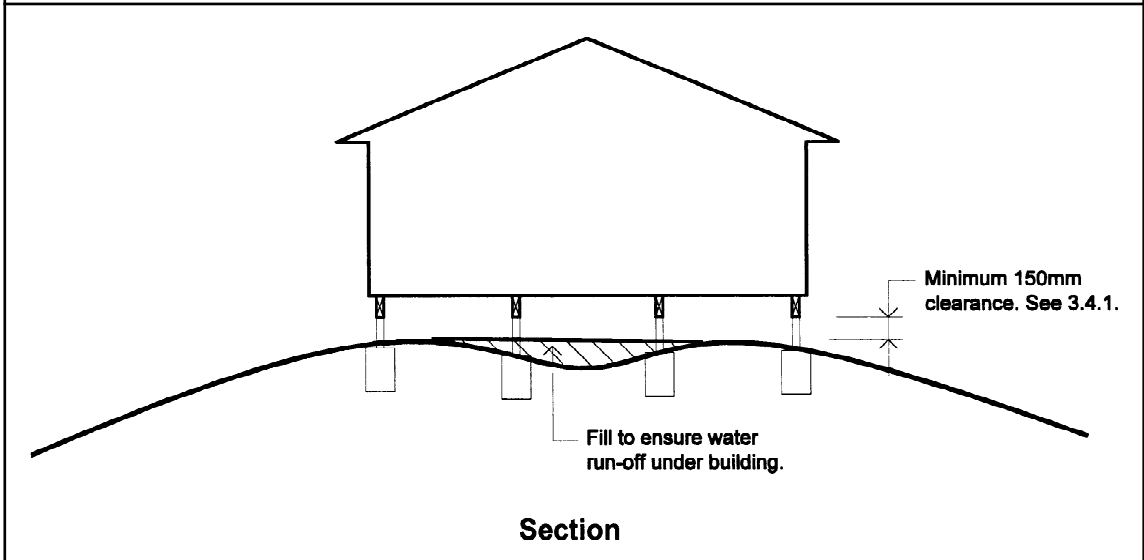

3.1.2.4 Subsoil drainage

Where a subsoil drainage system is installed to divert sub-surface water away from the area beneath the building it must comply with the following:

Explanatory information:

Subsoil drainage may need to be installed where subsoil water movement could damage buildings through the build up of excessive moisture or lateral water pressure on footings.

- (a) The depth to the top of the drain must not be less than 400 mm into the soil; and not less than 100 mm below any adjacent—
 - (i) pavement level; and
 - (ii) footing base.
- (b) Trench bases (as appropriate) must be graded to a uniform fall to suit the following—
 - (i) parallel with pavement grade; and
 - (ii) parallel with overall grade of footings; and
 - (iii) not less than 1:300.
- (c) The bottom of the trench must be well compacted and evenly graded.
- (d) The drain must be laid true to line and gradient on the bottom of the trench or where rock is encountered, on compacted bedding.
- (e) Silt pits or sumps of a suitable size for expected water flow, must be provided at the outlet end of each subsoil drain before it discharges into an impervious drainage line.

Explanatory information:

Silt pits designed to control the amount of silt entering the drainage system are usually installed where the excavation on a *site* exceeds 1 m and there is a need to drain subsoil water movement.

Silt pits are typically prefabricated and designed to suit a range of conditions. Heavy duty silt pits are not commonly used in domestic applications except in areas subject to traffic (such as where a driveway runs down towards a garage located under a dwelling).

To be effective the silt pit must be maintained by regular cleaning.

- (f) Outlets must be installed through walls of silt pits not less than 50 mm below the lowest point of the inlet (see [Figure 3.1.2.4](#)).

Figure 3.1.2.4

CONSTRUCTION OF SILT PITS

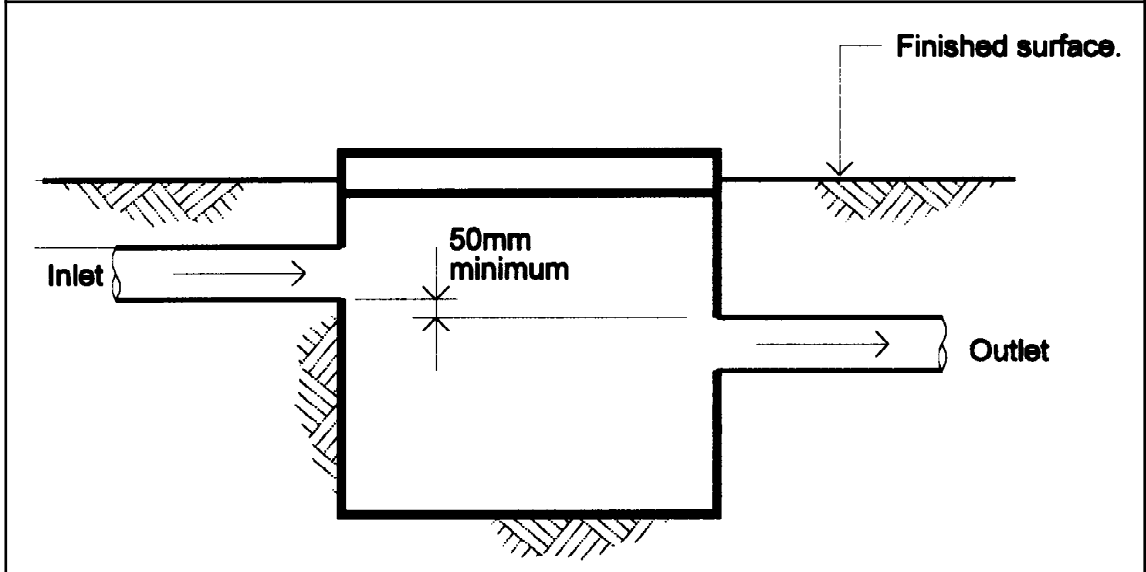

- (g) Drainage trenches in clay soils using sand filters must be constructed in accordance with [Figure 3.1.2.5](#).

Figure 3.1.2.5

BACKFILLING OF SUBSOIL DRAINS

Note:

The impervious fill may be omitted if the drain is also designed to collect *surface water*.

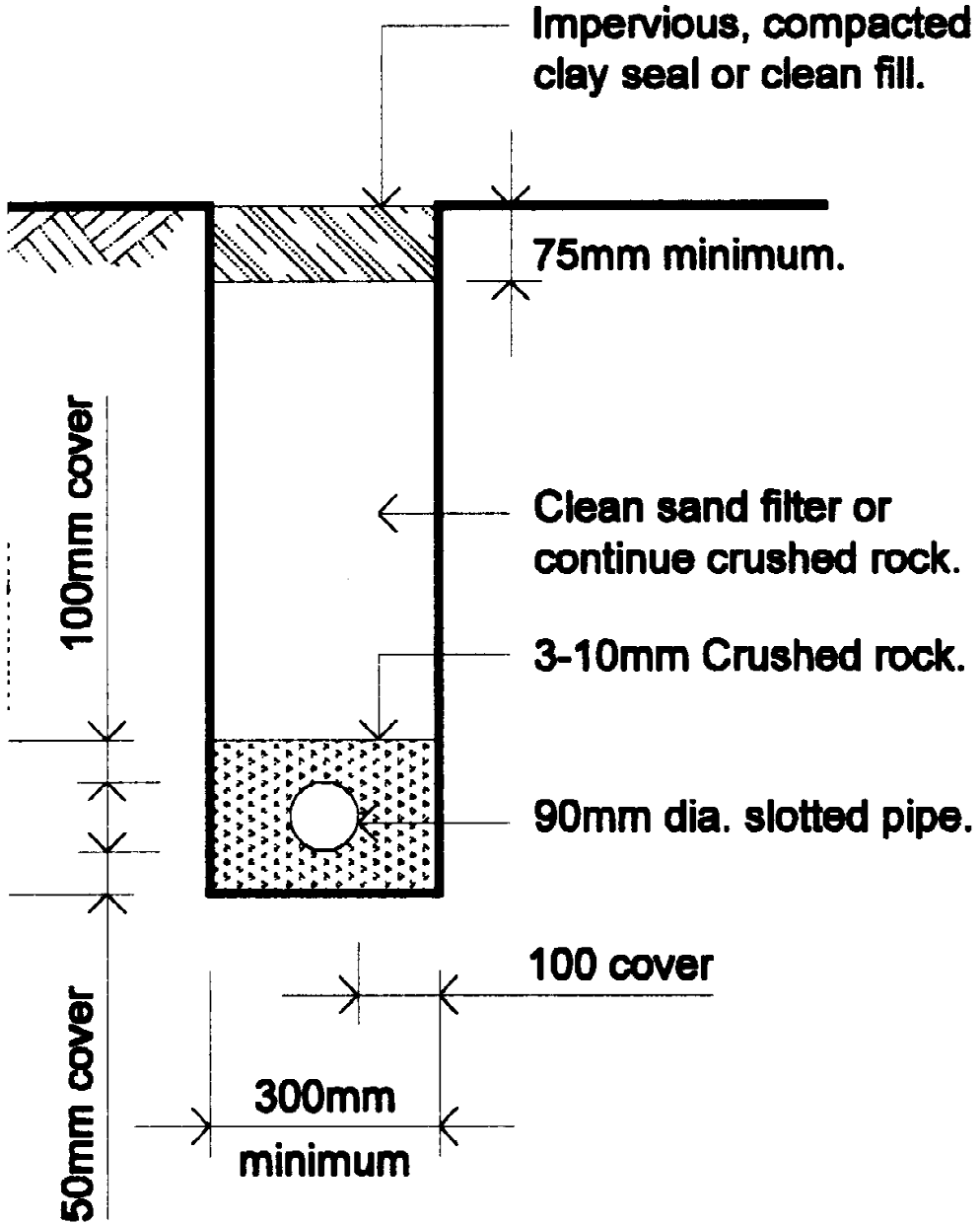

Explanatory information:

The design of alternative subsoil drains will need to consider the nature of the soil and anticipated water level and movement. One of the main concerns with subsoil drains is to keep fine soil particles from clogging the soil filters and accordingly preventing free water movement.

The following are various configurations for subsoil drains using geotextile filters and different pipe configurations. Drainage may be achieved by trenches filled with filter material or enhanced using pipes such as slotted UPVC or geotextile wrapped PVC.

Subsoil drains may also be required on the uphill side of cut and fill sites; adjacent deep strip footings, behind retaining walls, adjacent to basement walls etc in soil with poor drainage qualities or excessive sub-water movement.

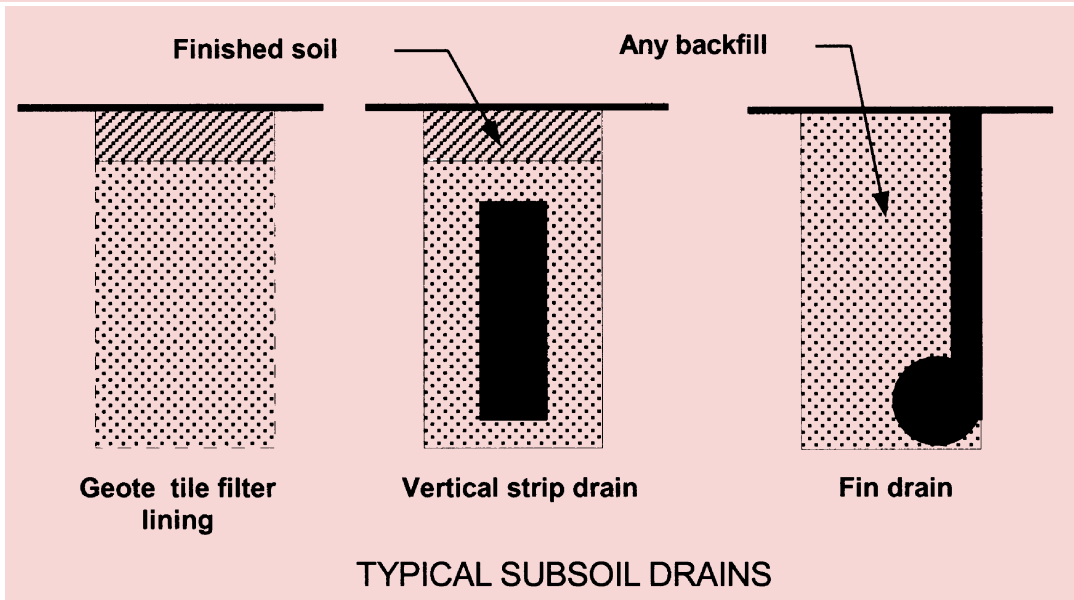

3.1.2.5 Stormwater drainage

Where a stormwater drainage system is installed, it must comply with the following:

- (a) The position and manner of discharge of the stormwater drainage system must be to the satisfaction of the *appropriate authority*.
- (b) The stormwater drainage system must be designed so that any overflow during heavy rain periods is prevented from flowing back into the building.

Explanatory information:

The manner of discharge of stormwater drainage systems includes consideration of discharge points. Some examples of discharge points which may be acceptable to the *appropriate authority* are:

- (a) A legal discharge point at the allotment boundary.
- (b) On-site catchment systems, such as stormwater tanks.
- (c) On-site soil drainage systems, such as soaker wells.

Explanatory information:

Stormwater drainage systems specified in the *Housing Provisions* are not designed to remove all of the water during exceptionally heavy rain, especially in tropical areas. Accordingly, it is necessary to design and install the system so that when overflowing occurs any water is directed away from the inside of the building and away from the building *foundation*.

To ensure that roof gutters do not overflow into the building consideration should be given to using slotted gutters, locating the gutter so that it is below the top edge of the fascia, the installation of rainwater heads with overflow slots etc.

Special attention needs to be given to box gutters, valley gutters etc located above the internal areas of a building. In these situations if adequate overflow controls cannot be implemented there may be a need to increase the size and capacity of drainage components to remove all water anticipated during heavy rain periods.

(c) Cover to stormwater drains

The cover to 90 mm Class 6 UPVC stormwater drains installed underground must be not less than—

- (i) under soil—100 mm; or
- (ii) under paved or concrete areas—50 mm; or
- (iii) under areas subject to light vehicle traffic—
 - (A) reinforced concrete—75 mm; or
 - (B) paved—100 mm.

Explanatory information:

Different depths of soil cover (or no cover at all) can be achieved using other types of pipes. The cover specified is measured from the top of the pipe to either the finished ground level or, in the case of paved or concreted areas, to the underside of the paving or concrete.

PART 3.1.3 TERMITE RISK MANAGEMENT

Definitions

3.1

The following definitions are used in this Part:

Primary building element means a member of a building designed specifically to take part of the building loads and includes roof, ceiling, floor, stairway or ramp and wall framing members including bracing members designed for the specific purpose of acting as a brace to those members.

Explanatory information:

The loads to which a building may be subjected are dead, live, wind, snow and earthquake loads. Further information on building loads can be found in AS 1170.1 or AS/NZS 1170.1.

STATE AND TERRITORY VARIATIONS

In Queensland delete definition of primary building element and replace with the following:

Primary building element means—

- (a) a member of a building designed specially to take part of the building loads and includes roof, ceiling, floor, stairway or ramp and wall framing members including bracing members designed for the specific purpose of acting as a brace to those members; and
- (b) door jambs, window frames and reveals, architraves and skirtings.

3.1.3 Application of this Part

- (a) The requirements of this Part apply when a *primary building element* of a Class 1 and 10 building is considered susceptible to termite attack.
- (b) This Part does not apply to Class 1 and 10 buildings as follows (see also [Figure 3.1.3.1](#)):
 - (i) Buildings in areas where subterranean termites are not known to present a potential risk of attack to the *primary building elements* of the building.

Explanatory information:

Termites are not considered to be a risk in Tasmania and a lesser risk in parts of Victoria. The *appropriate authority* may have records of termite activity for each area and may be able to advise you on whether termite risk management is needed.

- (ii) Buildings that have all their *primary building elements* constructed of one, or a combination of, the following materials:

- (A) Steel, aluminium or other metals.
 - (B) Concrete.
 - (C) Masonry.
 - (D) Fibre-reinforced cement.
 - (E) Naturally termite resistant timber in accordance with Appendix C of AS 3660.1.
 - (F) Preservative treated timber in accordance with Appendix D of AS 3660.1.
- (iii) Buildings in Tasmania.

Explanatory information:

Where individual *primary building elements* are susceptible to termite attack and the remainder of the *primary building elements* are constructed of termite resistant materials, only the susceptible elements need to be provided with a termite barrier.

STATE AND TERRITORY VARIATIONS

3.1.3(b)(ii)(E) is replaced by the following clause in the Northern Territory

(E) Naturally termite resistant timber in accordance with Appendix C of AS 3660.1 in areas where *Mastotermes darwiniensis* are not prevalent.

Figure 3.1.3.1

FLOW CHART FOR IDENTIFYING IF A TERMITE BARRIER IS REQUIRED

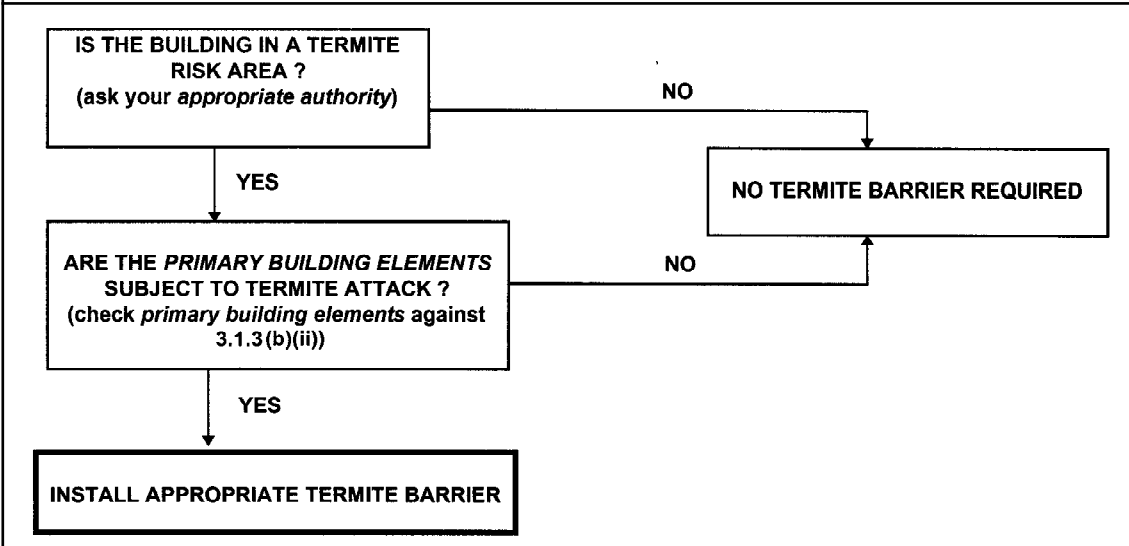

Appropriate Performance Requirements:

Where an alternative termite barrier or system is proposed as an *Alternative Solution* to that described in **Part 3.1.3**, that proposal must comply with—

- (a) *Performance Requirement P2.1*: and
- (b) the relevant *Performance Requirements* determined in accordance with **1.0.10**.

A. Acceptable construction manual

3.1.3.0 Acceptable construction manual

Performance Requirement P2.1 is satisfied for termite risk management if—

- (a) a termite barrier is installed in a Class 1 or 10 building to minimise the risk of termite attack to *primary building elements* in accordance with AS 3660.1—Termite management—New building work; and
- (b) a durable notice is installed in accordance with **3.1.3.2(b)**.

STATE AND TERRITORY VARIATIONS

In the Northern Territory delete 3.1.3.0(b) and insert 3.1.3.0(b) and (c) as follows:

- (b) a durable notice is installed in accordance with **3.1.3.2(b)**; and
- (c) additional termite risk management measures are used in areas where *Mastotermes darwiniensis* are prevalent.

STATE AND TERRITORY VARIATIONS

In Queensland delete 3.1.3.0 and replace with the following:

3.1.3.0 Acceptable construction manual

Performance Requirements P2.1 and **P2.1.1** are satisfied for termite risk management if—

- (a) a termite barrier is installed in a Class 1 or 10 building to minimise the risk of termite attack to *primary building elements* in accordance with AS 3660.1—Termite management—New building work, except that in regard to Clause 8.8.2, and Clause 8.8.3 where access for visual inspection in accordance with **3.7.2** is not possible, a hand sprayed chemical barrier must not be used; and
- (b) where a chemical barrier is used to protect the external perimeter of the building, the barrier must be—
 - (i) installed by excavating trenches, treating the exposed trench and backfilling the trench with treated material; and
 - (ii) protected by a 50 mm thick concrete cover strip not less than 300 mm wide measured from the external wall of the building; and
- (c) durable notices are installed in accordance with **3.1.3.2(b)**.

B. Acceptable construction practice

3.1.3.1 Application

Compliance with this Part satisfies *Performance Requirement P2.1* for termite risk management.

Explanatory information:

The intent of these requirements is to provide for a termite barrier that will ensure that termites will not enter a building by a concealed route. The installation of termite barriers will not stop termite activity from occurring on the site.

STATE AND TERRITORY VARIATIONS

3.1.3.1 is replaced by the following clause in the Northern Territory.

Compliance with this Part satisfies *Performance Requirement P2.1* for termite risk management provided that additional termite risk measures are used in areas where *Mastotermes darwiniensis* are prevalent.

STATE AND TERRITORY VARIATIONS

In Queensland delete 3.1.3.1 and replace with the following:

3.1.3.1 Application

Compliance with this Part satisfies *Performance Requirements P2.1* and *P2.1.1* for termite risk management.

3.1.3.2 Installation of termite barriers

- (a) A termite barrier or combination of barriers must be installed in accordance with—
 - (i) AS 3660.1; or
 - (ii) **3.1.3.3** for concrete slabs on ground; or
 - (iii) **3.1.3.4** for suspended floors.

(For barrier options see **Table 3.1.3.1**).
- (b) A durable notice must be permanently fixed to the building in a prominent location, such as in a meter box or the like, indicating—
 - (i) the method of termite risk management; and
 - (ii) the date of installation of the system; and
 - (iii) where a chemical barrier is used, its life expectancy as listed on the National Registration Authority label; and
 - (iv) the installer's or manufacturer's recommendations for the scope and frequency of future inspections for termite activity.

Explanatory information:

Durable notice

A durable notice must be fixed to the building in a prominent location advising the building occupants that the system should be inspected and maintained.

The notice should be clearly written, on a material that will not deteriorate or fade over time and be located in or near the meter box or similar location so that it can be easily seen and read by future owners of the building. Additional information may be included if desired by the person placing the notice.

STATE AND TERRITORY VARIATIONS

In Queensland delete 3.1.3.2 and replace with the following:

3.1.3.2 Installation of termite barriers

- (a) A termite barrier or combination of barriers must be installed in accordance with—
- (i) AS 3660.1 subject to **Clause 3.1.3.0(a)**; or
 - (ii) **3.1.3.3** for concrete slabs on ground; and
 - (iii) **3.1.3.4** for suspended floors.
- (For barrier options, see **Table 3.1.3.1**)
- (b) At least 2 durable notices must be permanently fixed to the building in prominent locations, such as in a meter box and a kitchen cupboard or the like, indicating—
- (i) the method of termite risk management; and
 - (ii) the date of installation of the system; and
 - (iii) where a chemical barrier is used, its life expectancy as listed on the National Registration Authority label; and
 - (iv) the installer's or manufacturer's recommendations for the scope and frequency of future inspections for termite activity.

Explanatory information:

Durable notices

At least two durable notices must be fixed to the building in prominent locations advising the building occupants that the system should be inspected and maintained. The notices should be clearly written, on a material that will not deteriorate or fade over time and be located in or near the meter box and in a kitchen cupboard or similar location so that it can be easily seen and read by future owners of the building. Additional information may be included if desired by the person placing the notice.

Table 3.1.3.1 ACCEPTABLE TERMITE BARRIERS

TERMITE MANAGEMENT SYSTEM (as per AS 3660.1)	FOOTING SYSTEM				
	Concrete slab on ground complying with AS 2870		Concrete slab on ground not complying with AS 2870		Suspended floors
	Penetrations and control joints	Slab perimeter	Beneath slab (includes penetrations and control joints)	Slab perimeter	
Slab edge exposure	Not suitable	Suitable	Not suitable	Suitable	Not applicable
Termite shielding	Not suitable	Not suitable	Not suitable	Not suitable	Suitable
Stainless steel mesh	Partial; or Full system	Partial; or Full system	Full system	Full system	Suitable
Graded stone	Partial; or Full system	Partial; or Full system	Full system	Full system	Partial; or Full system
Chemicals	Full system beneath slab	Perimeter system	Full system beneath slab	Perimeter system	Full system

Explanatory information:

A “partial system” as referred to in [Table 3.1.3.1](#) is one that when used in a combination with other systems, will form a “full system”. This is similar to [3.1.3.2](#) which refers to a “termite barrier or combination of barriers”.

For example, if a concrete slab is used as a barrier, it in itself will not provide a complete barrier to termites. Then, depending on the construction methods and the site conditions, additional requirements will be necessary for service penetrations. Each of these are “partial” treatment, yet when integrated, will form a “full system”.

In addition to the acceptable termite barriers described in [Table 3.1.3.1](#), other methods or systems can be used if it can be demonstrated that they meet the relevant *Performance Requirements* of the *Housing Provisions*. Forms of evidence of suitability are described in [Part 1.2](#)—Acceptance of design and construction.

STATE AND TERRITORY VARIATIONS

In Queensland delete Table 3.1.3.1 and replace with the following:

Table 3.1.3.1 ACCEPTABLE TERMITE BARRIERS

TERMITE MANAGEMENT SYSTEM (as per AS 3660.1)	FOOTING SYSTEM				
	Concrete slab on ground complying with AS 2870		Concrete slab on ground not complying with AS 2870		Suspended floors
	Penetrations and control joints	Slab perimeter	Beneath slab (includes penetrations and control joints)	Slab perimeter	
Slab edge exposure	Not suitable	Suitable	Not suitable	Suitable	Not applicable
Termite shielding	Not suitable	Not suitable	Not suitable	Not suitable	Suitable
Stainless steel mesh	Partial; or Full system	Partial; or Full system	Full system	Full system	Suitable
Graded stone	Partial; or Full system	Partial; or Full system	Full system	Full system	Partial; or Full system
Chemicals	Full system beneath slab subject to 3.1.3.0(a)	Perimeter system subject to 3.1.3.0(b)	Full system beneath slab subject to 3.1.3.0(a)	Perimeter system subject to 3.1.3.0(b)	Full system subject to 3.1.3.0(a)

3.1.3.3 Barriers for concrete slab-on-ground

- (a) Where a concrete slab-on-ground is to be used as part of a termite barrier system, the slab must be designed and constructed to comply with AS 2870, and—
 - (i) monolithic slabs must have penetrations and the perimeter of the slab treated in accordance with [Table 3.1.3.1](#) (see [Figure 3.1.3.2](#)); and
 - (ii) non-monolithic slabs must have penetrations, control joints and the perimeter of the slab treated in accordance with [Table 3.1.3.1](#) (see [Figure 3.1.3.3](#)).
- (b) Slabs not constructed in accordance with AS 2870 must have the full area beneath the slab and the perimeter treated in accordance with [Table 3.1.3.1](#).
- (c) The edge of a slab-on-ground may be used as a perimeter barrier provided—
 - (i) the slab edge is left exposed, not less than 75 mm above finished ground level; and
 - (ii) the face of the exposed edge is not rough or honeycombed and does not contain ripples caused by folds in vapour barrier or the like that could conceal termite activity; and
 - (iii) the exposed surface is not rendered, tiled, clad or concealed by *flashing*.

Figure 3.1.3.2

AREAS TO BE TREATED FOR CONCRETE SLAB ON GROUND

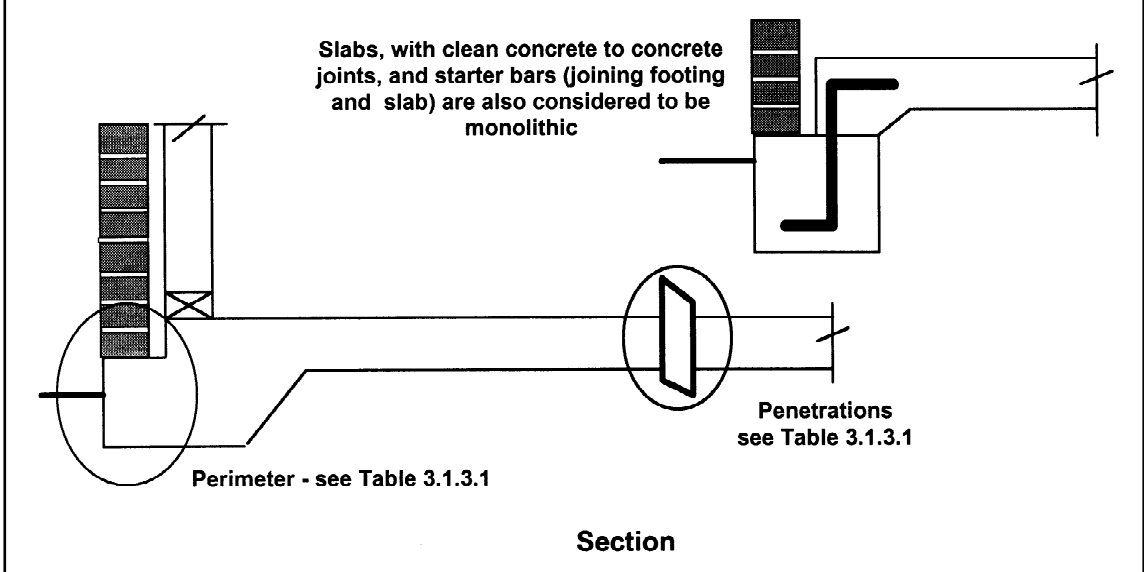
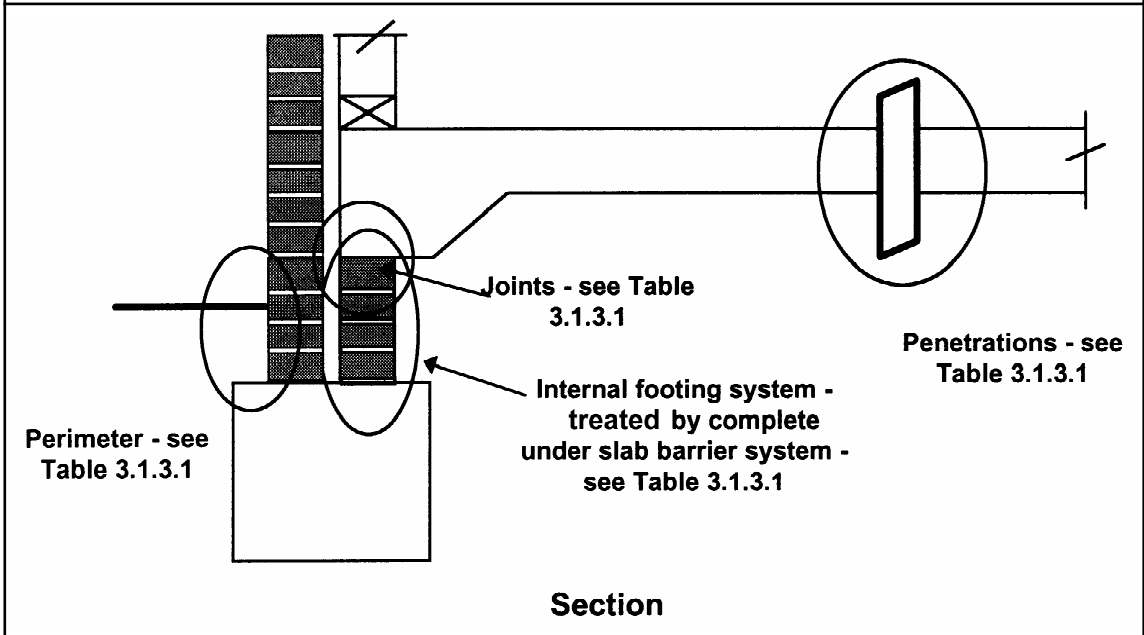

Figure 3.1.3.3

AREAS TO BE TREATED FOR CONCRETE SLABS



3.1.3.4 Barriers for suspended floors

The area beneath a suspended floor of a building must be treated—

- (a) by installing a barrier system in accordance with [Table 3.1.3.1](#); and

- (b) by providing sub-floor ventilation in accordance with [Part 3.4.1](#); and
- (c) where a barrier that needs to be inspected is installed, by providing access to the area of the barrier that needs inspection in accordance with AS 3660.1.

3.1.3.5 Attachments to buildings

- (a) Attachments to buildings such as downpipes and service pipes must have a gap to allow clear and uninterrupted visual inspection across the inspection zone.
- (b) Structures such as steps, verandahs, porches, access ramps, carports, trellises, decks, hot-water systems, airconditioners, or the like which are not provided with one of the barrier systems described in this Part, must be separated from the building by a gap of not less than 25 mm, to allow clear and uninterrupted visual inspection across the inspection zone.
- (c) Where attachments or structures, as outlined in [\(a\)](#) and [\(b\)](#), abut a building and there is no clear gap, a barrier must be provided to the attachment, regardless of the size of the attachment.
- (d) For the purposes of this clause, an inspection zone is an unobstructed space which termites must cross or pass in order to gain access to a building or structure and, as a consequence, reveal their presence during visual inspection.

Explanatory information—Termites:

1. Barriers—Part of a system

There are more than 350 species of termites in Australia, about 30 of which achieve economic importance by causing costly damage to building structures. Due to the nature of termites, it is extremely difficult to prevent them gaining access to a building.

In addition to the correct installation of a termite barrier, its effectiveness will rely on regular maintenance and competent inspection.

The requirements in the BCA are minimum requirements and owners of buildings may choose to incorporate additional termite management systems in their buildings.

2. The slab as a barrier

A concrete slab, designed and constructed in accordance with AS 2870, can form part of an acceptable termite barrier system. Cracking of the slab is common and does not necessarily indicate the failure of the termite barrier. Most cracks, including those that may appear quite wide on the surface do not necessarily extend for the full depth of the slab.

3. Slab edge exposure

This approach is similar to that applied to termite shields in that termite activity is forced onto the exposed edge of the slab where with regular inspections termite ingress via the perimeter of the building can be detected.

The exposed edge of the slab should be kept clean. Debris such as leaves should be removed to ensure the full 75 mm of the slab is always visible.

4. Treatment of sub-floor areas

The area beneath a building requires special attention to ensure the effectiveness of the termite barrier. The following points should be observed.

- a. Sub-floor ventilation—In suspended floor areas it is important that termite activity is not encouraged by inadequate subfloor ventilation. In conjunction with physical or

chemical barriers air flow is critical. Air flow will not only restrict the growth of fungus which attacks subfloor members (which makes them more susceptible to termite attack), but also creates a climatic atmosphere less conducive to termite activity.

- b. Subfloor access—Termite shielding installed below suspended floors relies on access for both inspection and maintenance to be effective. Accordingly, minimum clearance heights will need to be achieved between the building structure (including ducts) and the ground to allow easy access to all areas where termite shields are used.

Perimeter access doors will also be needed where access is required for inspection and maintenance.

PART **3.2**

FOOTINGS AND SLABS

- 3.2 Footings and slabs**
- 3.2.2 Preparation**
- 3.2.3 Concrete and Reinforcing**
- 3.2.4 Site Classification**
- 3.2.5 Footing and Slab Construction**

PART 3.2 CONTENTS

PART 3.2 FOOTINGS AND SLABS

Explanatory Information

3.2 Footings and Slabs

- 3.2 Definitions
- 3.2.0 Acceptable construction manual
- 3.2.1 Application

3.2.2 Preparation

- 3.2.2.1 Excavation for footings
- 3.2.2.2 Filling under concrete slabs
- 3.2.2.3 Foundations for footings and slabs
- 3.2.2.4 Slab edge support on sloping sites
- 3.2.2.5 Stepped footings
- 3.2.2.6 Vapour barriers
- 3.2.2.7 Edge rebates

3.2.3 Concrete and Reinforcing

- 3.2.3.1 Concrete
- 3.2.3.2 Steel reinforcement

3.2.4 Site Classification

- 3.2.4.1 Site classification

3.2.5 Footing and Slab Construction

- 3.2.5.1 Footing and slab construction
- 3.2.5.2 Footings and slabs to extensions to existing buildings
- 3.2.5.3 Shrinkage control
- 3.2.5.4 Minimum edge beam dimensions
- 3.2.5.5 Footings for fireplaces on Class A and S sites
- 3.2.5.6 Stump footing details

PART 3.2

EXPLANATORY INFORMATION

Explanatory information:

Explanatory information: This Part specifies the requirements for the excavation and filling for the footing or slab together with the construction of various alternative concrete slab and footing configurations. The slab and footing configurations detailed in [Part 3.2.5](#) are only suitable for the specified soil classifications. The requirements contained in the remainder of this Part are more general and may be applied to all slab and footing construction.

PART 3.2 FOOTINGS AND SLABS

Appropriate Performance Requirements:

Where an alternative footing system is proposed as an *Alternative Solution* to that described in Part 3.2, that proposal must comply with—

- (a) *Performance Requirement P2.1*; and
- (b) *Performance Requirement P2.2.3*,
- (c) the relevant *Performance Requirements* determined in accordance with **1.0.10**.

Definitions

3.2

The following definitions are used in this Part:

Articulated masonry means masonry construction in which special provisions have been made for movement by articulation (see **3.3.1.8**).

Clad frame means timber or metal frame construction with exterior timber or sheet wall cladding that is not sensitive to minor movement and includes substructure masonry walls up to 1.5 m high.

Controlled fill means material that has been placed and compacted in layers with compaction equipment (such as a vibrating plate) within a defined moisture range to a defined density requirement.

Finished ground level means the ground level adjacent to footing systems at the completion of construction and landscaping.

Footing means construction that transfers the load from the building to the *foundation*.

Loadbearing wall , for the purposes of this part, means any wall imposing on the footing a load greater than 10 kN/m.

Mixed construction means a building consisting of more than one form of construction, particularly in double-storey buildings.

Rolled fill means material placed in layers and compacted by repeated rolling by an excavator.

Single leaf masonry means outer walls constructed with a single thickness of masonry unit.

Waffle raft means a stiffened raft with closely spaced ribs constructed on the ground and with slab panels supported between ribs.

A. Acceptable construction manual

3.2.0

Performance Requirements P2.1 and *P2.2.3* are satisfied for footings and slabs if they are installed in accordance with one of the following manuals:

- (a) The footing or slab is constructed in accordance with AS 2870.
- (b) Piled footings are designed in accordance with AS 2159.

Explanatory information:

Composite construction—design requirements for other materials that may be used in combination with the above footing systems, including the use of heavy steel support beams etc are described in *Part 3.11*—structural design codes.

STATE AND TERRITORY VARIATIONS

In New South Wales delete 3.2.0(a) and insert NSW 3.2.0(a) as follows:

NSW 3.2.0(a)

The footing or slab is constructed in accordance with AS 2870 except that for the purposes of Clause 5.3.3.1 of AS 2870 a damp-proofing membrane is required to be provided.

B. Acceptable construction practice

3.2.1 Application

Compliance with this Part satisfies *Performance Requirements P2.1* and *P2.2.3* for footings and slabs, provided—

- (a) the footing is on a Class A, S, M, M-D, H or H-D *site* (classified in accordance with AS 2870) with a uniform bearing capacity; and
- (b) the slab is not more than 30 m long; and
- (c) slabs containing permanent joints (eg construction joints) are not used; and
- (d) the structure supported by the footing does not contain—
 - (i) more than two trafficable floors; or
 - (ii) a wall height exceeding 8 m, excluding any gable; and
- (e) the footing does not support more than one concrete slab; and

Explanatory Information:

For the purpose of (e) split level slabs are considered as one slab.

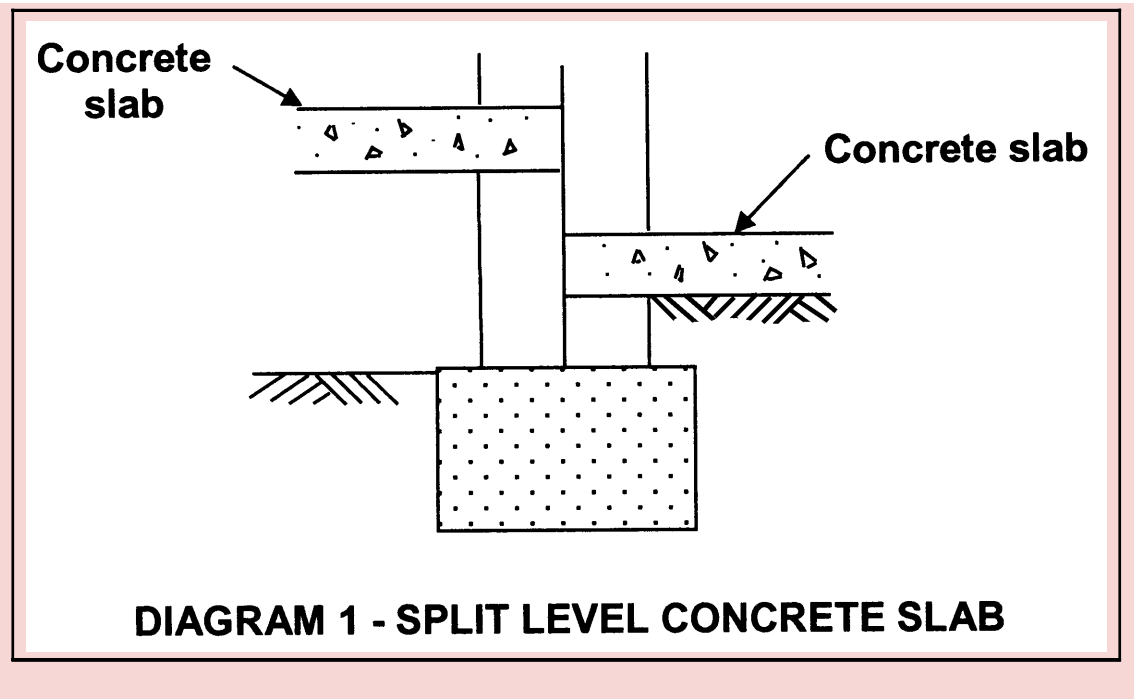

- (f) the building does not include wing walls or masonry arches not detailed for movement in accordance with Cement and Concrete Association of Australia TN 61; and
- (g) single leaf earth or stone masonry walls do not exceed 3 m in height; and
- (h) the *site* is considered to be normal as defined in [Part 3.1.1](#), and
- (i) the *site* is not located in an *alpine area*.

PART 3.2.2 PREPARATION

3.2.2.1 Excavation for footings

- (a) Excavation for footings, including thickenings for slabs and pads must be clean cut with vertical sides, wherever possible.
- (b) The base of the excavation must be—
 - (i) for flat *sites*, generally level but may slope not more than 1:40 to allow excavations to drain; and
 - (ii) sloping *sites* at an angle of not more than 1:10; and
 - (iii) stepped footings in accordance with [3.2.2.5](#).
- (c) Footing excavations must be free of loose earth, tree roots, mud or debris immediately before pouring concrete.
- (d) Topsoil containing grass roots must be removed from the area on which the footing will rest.
- (e) Excavation depths and soil cuts must comply with [Part 3.1.1](#).

STATE AND TERRITORY VARIATIONS

3.2.2.1(e) does not apply in New South Wales.

Note: In New South Wales the consent authority can determine to place controls on siteworks associated with the erection of a building, by imposing conditions when it grants development consent. These controls can include the safeguarding of excavations and backfilling, provision of retaining walls to prevent soil movement and support for neighbouring buildings. Information addressing siteworks can be found in the Department of Infrastructure Planning and Natural Resources' Act and Regulation note "Health, safety and amenity during construction".

- (f) On loose sand *sites* or *sites* subject to wind or water erosion, the depth below *finished ground level* for footings must be not less than 300 mm.
- (g) Height of finished slab-on-ground must be in accordance with [3.1.2.3\(b\)](#).

3.2.2.2 Filling under concrete slabs

Filling placed under a slab (except where the slab is suspended) must comply with the following:

- (a) Filling must be either *controlled fill* or *rolled fill* as follows:
 - (i) Sand used in *controlled fill* or *rolled fill* must not contain any gravel size material and achieve a blow count of 7 or more per 300 mm using the test method described in AS 1289, Method 6.3.3.
 - (ii) Clay used in *controlled fill* or *rolled fill* must be moist during compaction.
 - (iii) *Controlled fill*:
 - (A) Sand fill up to 800 mm deep—well compacted in layers not more than 300 mm deep by vibrating plate or vibrating roller.

- (B) Clay fill up to 400 mm deep—well compacted in layers of not more than 150 mm by a mechanical roller.
- (iv) *Rolled fill*:
 - (A) Sand fill up to 600 mm deep—compact in layers of not more than 300 mm by repeated rolling by an excavator or other suitable mechanical equipment.
 - (B) Clay fill up to 300 mm deep—compact in layers of not more than 150 mm by repeated rolling by an excavator or similar machine.
- (b) Fill with a depth greater than that specified in (a) must be installed in accordance with AS 3798.
- (c) A level layer of clean quarry sand must be placed on top of the fill, with a depth of not less than 20 mm.
- (d) A graded stone termite barrier complying with Part 3.1.3 may be substituted for the sand required in (c).

3.2.2.3 Foundations for footings and slabs

Footings and slabs, including internal and edge beams, must be founded on soil with an allowable bearing pressure as follows:

- (a) Slab panels, load support panels and internal beams—natural soil with an allowable bearing pressure of not less than 50 kPa or *controlled fill* or *rolled fill* compacted in accordance with 3.2.2.2.
- (b) Edge beams connected to the slab—natural soil with an allowable bearing pressure of not less than 50 kPa or *controlled fill* compacted in accordance with 3.2.2.2(a)(iii) and extending past the perimeter of the building 1 m with a slope ratio not steeper than 2 horizontal to 1 vertical (see Figure 3.2.2.1).
- (c) Pad footings, strip footings and edge beams not connected to the slab, must be—
 - (i) founded in natural soil with an allowable bearing pressure of not less than 100 kPa; or
 - (ii) for Class A and S sites they may be founded on controlled sand fill in accordance with 3.2.2.2(a).

3.2.2.4 Slab edge support on sloping sites

Footings and slabs installed on the low side of sloping sites must be as follows:

- (a) Slab panels—in accordance with 3.2.2.3(a).
- (b) Edge beams—
 - (i) supported by *controlled fill* in accordance with 3.2.2.3(b) (see Figure 3.2.2.1, Option 1); or
 - (ii) supported by deepened edge beams or bulk piers designed in accordance with AS 3600 (see Figure 3.2.2.1, Option 2); or
 - (iii) deepened (as per AS 2870) to extend into the natural soil level with a bearing capacity in accordance with 3.2.2.3(b) (see Figure 3.2.2.1, Option 3); or
 - (iv) stepped in accordance with AS 2870.
- (c) Edge beams not connected to the slab, pad footings and strip footings—founded in accordance with 3.2.2.3(c).

- (d) Where an excavation (cut) of the natural ground is used it must be in accordance with [Part 3.1.1](#).

Figure 3.2.2.1

SLAB EDGE SUPPORT ON THE LOW SIDE OF SLOPING SITES

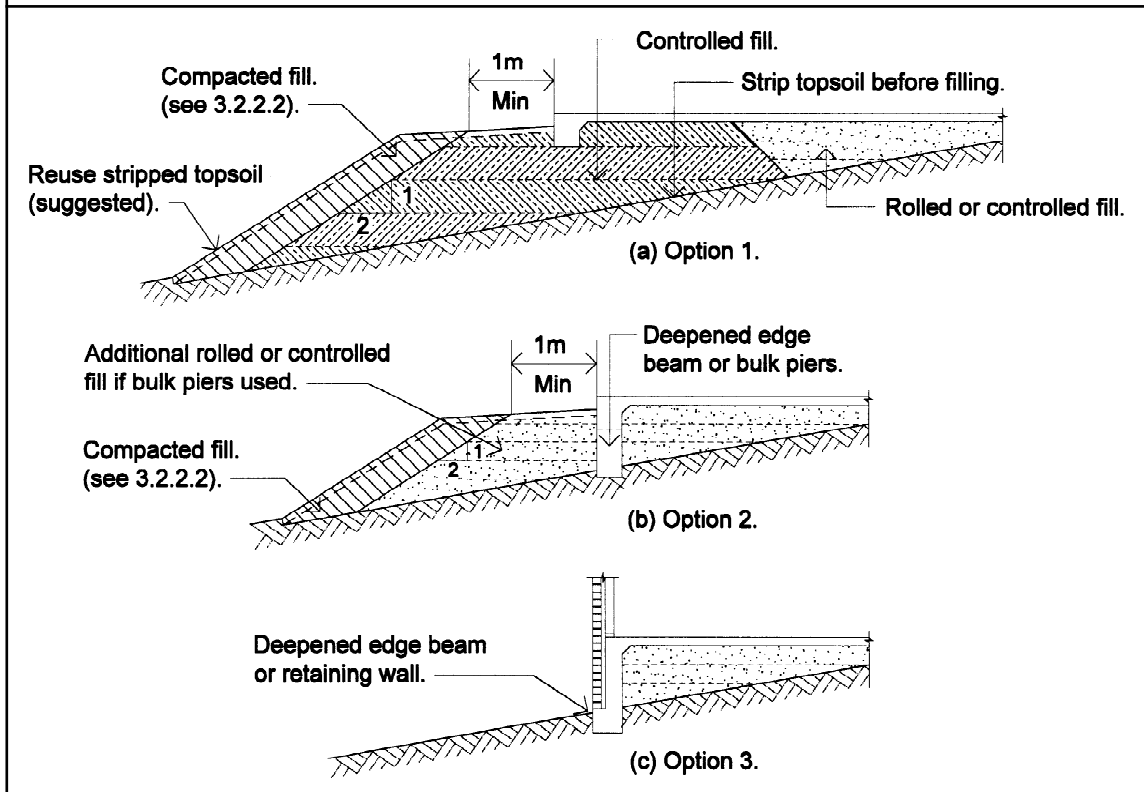

Explanatory information:

The *foundations* of a building are critical to its successful performance. As such, the soil must have the strength or bearing capacity to carry the building load with minimum movement.

The bearing capacity of a soil varies considerably and needs to be determined on a *site* by *site* basis. For this to occur, the appropriate people need to be consulted. These people may include a qualified engineer or experienced engineering geologist, or it may be determined by a person with appropriate local knowledge. The minimum bearing capacity (soil strength rating) may depend on the *site* conditions. The soil may be naturally undisturbed or be disturbed by building work or the like. Where soil is disturbed by building work and the like, the bearing capacity can be dramatically altered. This is typically the case for sloping *sites* where cut and fill procedures are used. In these situations the soil needs to be consolidated, generally via compaction, to achieve the *required* bearing capacity.

There are a number of alternatives for working on cut and filled sites. These are described in [Figure 3.2.2.1](#).

Option 1 of [Figure 3.2.2.1](#) refers to the controlled fill process which involves the compaction of fill in layers to achieve the bearing capacity described in [3.2.2.3](#). The depth of fill for each layer is specified to ensure effective compaction. Fill beyond these depths will need to be installed in accordance with AS 3798.

Option 2 and 3 of **Figure 3.2.2.1** refer to edge beams that extend through the fill into undisturbed soil which provides the **3.2.2.3** required bearing capacity. In this situation the fill is essentially only taking the internal slab loads.

3.2.2.5 Stepped footings

Stepped strip footings must be constructed as follows—

- (a) the base of the footing must be horizontal or have a slope of not more than 1:10; or
- (b) be stepped in accordance with one of the methods shown in **Figure 3.2.2.2**.

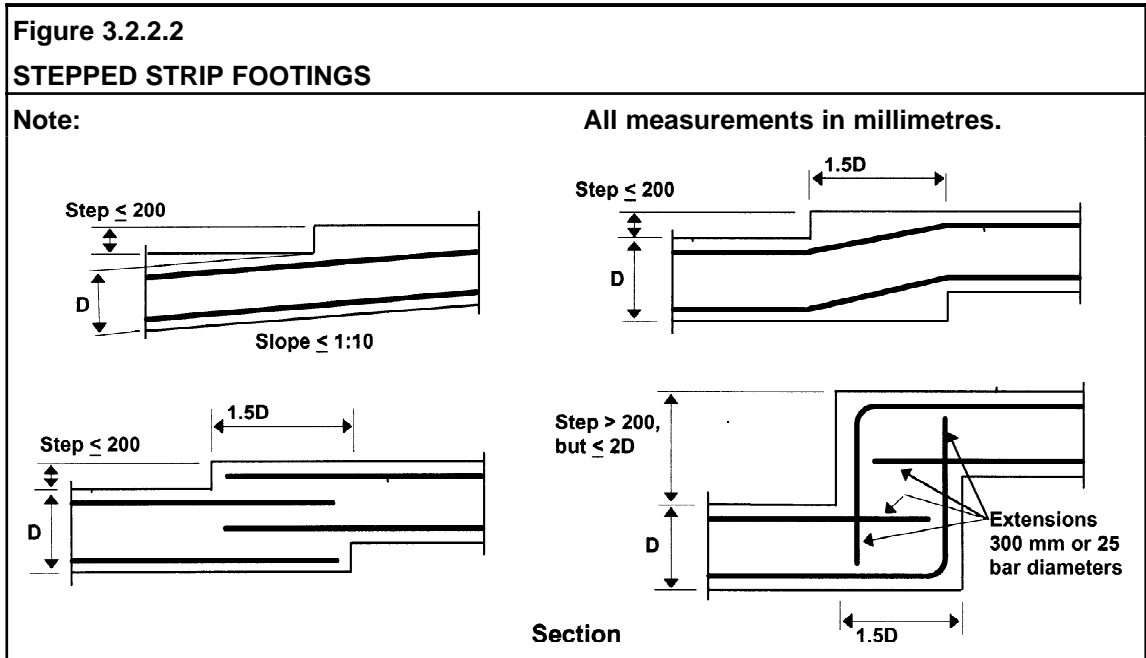

3.2.2.6 Vapour barriers

A vapour barrier must be installed under slab-on-ground construction for all Class 1 buildings and for Class 10 buildings where the slab is continuous with the slab of a Class 1 building as follows—

- (a) Materials

A vapour barrier must be—

- (i) 0.2 mm nominal thickness polyethylene film; and
- (ii) medium impact resistant, determined in accordance with criteria specified in clause 5.3.3.2(c) of AS 2870; and
- (iii) be branded continuously “AS 2870 Concrete underlay, 0.2 mm Medium impact resistance”.

- (b) Installation

A vapour barrier must be installed as follows—

- (i) lap not less than 200 mm at all joints; and
 - (ii) tape or seal with a close fitting sleeve around all service penetrations; and
 - (iii) fully seal where punctured (unless for service penetrations) with additional polyethylene film and tape.
- (c) The vapour barrier must be placed beneath the slab so that the bottom surface of the slab is entirely underlaid and extends under edge beams to finish at ground level in accordance with [Figure 3.2.2.3](#) (also see [Figure 3.3.4.9](#) for single skin masonry details).

STATE AND TERRITORY VARIATIONS

In South Australia delete 3.2.2.6 and insert SA 3.2.2.6 as follows:

SA 3.2.2.6 Damp-proofing membrane

A continuous damp-proofing membrane must be installed under slab-on-ground construction for all Class 1 buildings as follows—

(a) Materials

A damp-proofing membrane must be—

- (i) 0.2 mm nominal thickness polyethylene film; and
- (ii) high impact resistant with resistance to puncturing and moisture penetration, determined in accordance with criteria specified in clause 5.3.3.2(c) of AS 2870; and
- (iii) be branded continuously “AS 2870 Concrete underlay, 0.2 mm High impact resistance” together with the manufacturer’s or distributor’s name, trade mark or code.

(b) Installation

A damp-proofing membrane must be installed as follows—

- (i) lap not less than 200 mm at all joints; and
- (ii) tape or seal with a close fitting sleeve around all service penetrations; and
- (iii) fully seal where punctured (unless for service penetrations) with additional polyethylene film and tape.

- (c) The damp-proofing membrane must be placed beneath the slab so that the bottom surface of the slab is entirely underlaid and extends under edge beams to finish at ground level in accordance with [Figure 3.2.2.3](#) (also see [Figure 3.3.4.9](#) for single skin masonry details).

In New South Wales delete 3.2.2.6 and insert NSW 3.2.2.6 as follows:

NSW 3.2.2.6 Damp-proofing membrane

A damp-proofing membrane must be installed under slab-on-ground construction for all Class 1 buildings and for Class 10 buildings where the slab is continuous with the slab of a Class 1 building as follows—

(a) Materials

A damp-proofing membrane must be—

- (i) 0.2 mm nominal thickness polyethylene film; and
 - (ii) high impact resistant, determined in accordance with criteria specified in clause 5.3.3.2(c) of AS 2870; and
 - (iii) be branded continuously "AS 2870 Concrete underlay, 0.2 mm High impact resistance".
- (b) Installation
- A damp-proofing membrane must be installed as follows—
- (i) lap not less than 200 mm at all joints; and
 - (ii) tape or seal with a close fitting sleeve around all service penetrations; and
 - (iii) fully seal where punctured (unless for service penetrations) with additional polyethylene film and tape.
- (c) The vapour barrier must be placed beneath the slab so that the bottom surface of the slab is entirely underlaid and extends under edge beams to finish at ground level in accordance with [Figure 3.2.2.3](#) (also see [Figure 3.3.4.9](#) for single skin masonry details).

Note:

A range of polyethylene films can be used, including black film and orange film, provided they satisfy the requirements for high impact resistance in accordance with the criteria specified in clause 5.3.3.2(c) of AS 2870.

3.2.2.7 Edge rebates

Edge rebates for slab-on-ground, stiffened raft or *waffle raft* with masonry cavity or veneer construction must comply with the following:

- (a) The rebate must not be less than 20 mm, except as provided for in [\(d\)](#).
- (b) Exterior masonry must not overhang more than 15 mm past the edge of the slab.
- (c) The edge rebate must be flashed and drained in accordance with [Part 3.3.4](#) and where it cannot be flashed it must be filled with mortar.
- (d) Edge rebates are not required for single-leaf masonry.

Explanatory information:

See [3.2.5.4](#) for minimum edge beam details.

Figure 3.2.2.3

ACCEPTABLE VAPOUR BARRIER AND DAMP-PROOFING MEMBRANE LOCATION

Note:

All dimensions in mm.

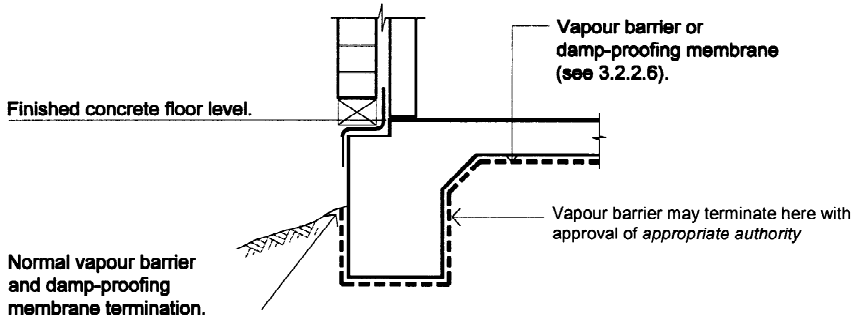

(a) Minimum rebate for cavity masonry or veneer wall.

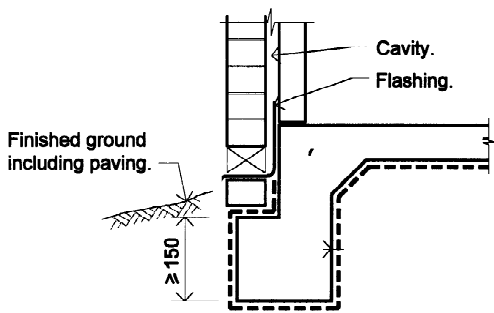

(b) Deep edge rebate alternative.

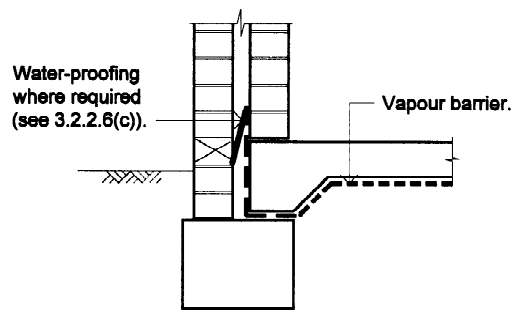

(c) Masonry alternative.

PART 3.2.3 CONCRETE AND REINFORCING

3.2.3.1 Concrete

Concrete must comply with the following:

- (a) Concrete must be manufactured to comply with AS 3600; and—
 - (i) have a strength at 28 days of not less than 20 MPa (denoted as N20 grade); and
 - (ii) have a 20 mm nominal aggregate size; and
 - (iii) have a nominal 80 mm slump.
- (b) Water must not be added to the mix to increase the slump to a value in excess of that specified.
- (c) Concrete must be placed and compacted in accordance with good building practice.
- (d) In hot (above 30°Celsius) and windy conditions concrete must be cured by covering with plastic sheeting, spraying with a liquid membrane curing compound or ponding of water on the top surface.

STATE AND TERRITORY VARIATIONS

In South Australia after 3.2.3.1(d) insert SA 3.2.3.1(e), (f) and (g) as follows:

- (e) Concrete in slabs must be adequately compacted, and slab surfaces, including edges, moist cured for 7 days.
- (f) After vertical surfaces are stripped of formwork, slab edges must be finished prior to curing.
- (g) Loading of concrete slabs with stacked materials or building plant must not occur for a minimum of 7 days after pouring although construction of wall frames and setting out brickwork may be undertaken during this period.

Explanatory information:

Compacting concrete by vibration removes air pockets and works the concrete thoroughly around reinforcement, service penetrations etc and into corners of formwork to increase durability and resistance to termite infestation and salt damp attack. Care should be taken not to over-vibrate.

The finishing and curing of slab edges provides an improved edge finish which is resistant to edge dampness.

Explanatory information:

1. Complete discharge of the concrete from the truck should be made within one and a half hours of initial mixing with water unless a suitable retarder has been specified.
2. Care should be taken when using chemical curing methods, because some products may not be compatible with adhesives used to fix surface finishes to the slab.

3.2.3.2 Steel reinforcement

- (a) Materials used for reinforcing steel must comply with AS 2870 and be—
- (i) welded wire reinforcing fabric; or
 - (ii) trench mesh; or
 - (iii) steel reinforcing bars.
- (b) Steel reinforcing bars may be substituted for trench mesh in accordance with [Table 3.2.3.2](#).

Explanatory information:

Reinforcement types referenced in this Part are described as follows:

1. Square mesh is designated in terms of the diameter of each bar and the spacing of consecutive bars. For example, SL62 consists of 6 mm bar at 200 mm spacings.
2. Trench mesh is designated in terms of the number of longitudinal bars and the diameter of each bar. For example, 3-L11TM consists of 3 longitudinal bars each of which are 11 mm in diameter.
3. Reinforcing bars are designated in terms of the number of bars and the diameter of each bar. For example, 6-N12 consists of 6 bars each of which are 12 mm in diameter.

- (c) Minimum laps for reinforcement as shown in [Table 3.2.3.1](#) and [Figure 3.2.3.1](#) must be provided where reinforcing is used.

Table 3.2.3.1 MINIMUM LAP FOR REINFORCEMENT

Reinforcement	Minimum splice (mm)	Minimum Lap at “T” intersections	Minimum Lap at “L” intersections
Steel reinforcing bars	500	Full width across the junction	One outer bar must be bent and continue 500 mm (min) around corner
Trench mesh	500	Full width across the junction	Full width across the junction
Square and Rectangular Mesh	The two outermost transverse wires of one sheet must overlap the two outermost transverse wires of the other.	Not applicable	Not applicable

Figure 3.2.3.1

LAPS IN REINFORCEMENT

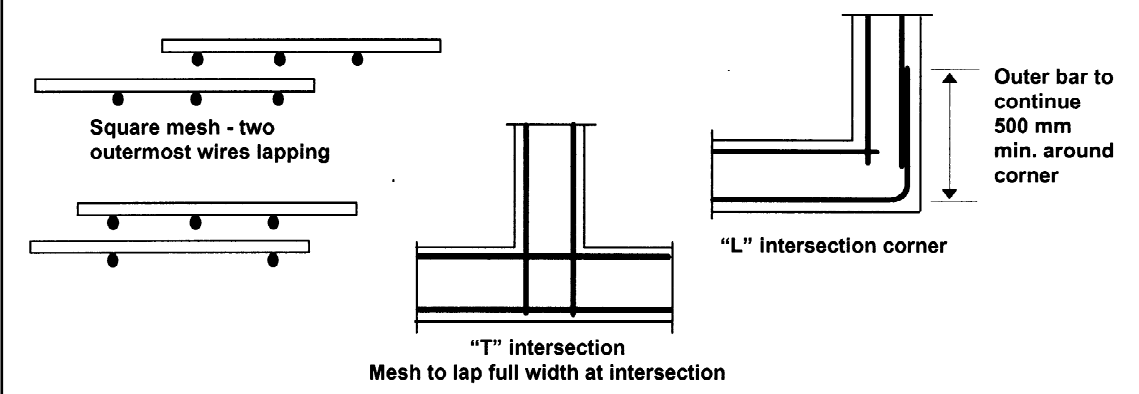

Table 3.2.3.2 ALTERNATIVE MESH/REINFORCING BAR SIZES

Note: Where necessary 2 layers of mesh may be used.

Trench mesh (TM)	Area—mm ²	Reinforcing bar alternative	Trench mesh alternative
2-L8TM	91	2-N10 or 1-N12	not applicable
3-L8TM	136	2-N10 or 2-N12	not applicable
4-L8TM	182	2-N12	2-L11TM
5-L8TM	227	2-N12	3-L11TM
2-L11TM	180	1-N16 or 2-N12	2x2-L8TM
3-L11TM	270	3-N12	2x3-L8TM
4-L11TM	360	2-N16	2x4-L8TM
2-L12TM	222	2-N12	3-L11TM
3-L12TM	333	3-N12	4-L11TM
4-L12TM	444	4-N12	5-L11TM

Notes:

- L11TM and L12TM may be replaced by RL1118 and RL1218 mesh respectively.
- L11TM may be replaced by two layers of L8TM.

- (d) Footings and slabs on ground must have concrete cover between the outermost edge of the reinforcement (including ligatures, tie wire etc) and the surface of the concrete of not less than:
- 40 mm to unprotected ground.
 - 30 mm to a membrane in contact with the ground.
 - 20 mm to an internal surface.
 - 40 mm to external exposure.

- (e) Reinforcement must be cleaned of loose rust, mud, paints and oils immediately prior to the concrete pour.

Explanatory information:

In order to obtain a good bond between concrete and reinforcement, the reinforcement should be free of contamination by mud, paint, oils, etc. It is not necessary for the reinforcement to be completely free of rust. Some rusting is beneficial in promoting a good bond as it roughens the surface of the steel. Loose rust, however, must be removed from the reinforcement.

- (f) Reinforcement must be placed as follows:
- (i) All reinforcement must be firmly fixed in place to prevent it moving during concreting operations.
 - (ii) Reinforcement must be supported off the ground or the forms by bar chairs made from wire, concrete or plastic.
 - (iii) When using wire chairs the minimum concrete cover (see [3.2.3.2\(d\)](#)) to the uncoated portion of the chair must be obtained.
 - (iv) Wire chairs on soft ground or plastic membrane must be placed on flat bases.
 - (v) Bar chairs must be spaced at not more than 800 mm centres for steel fabric.

Explanatory information:

Reinforcement is designed to be in a particular place so as to add strength or to control cracking of the concrete. A displacement from its intended location could make a significant difference to the life or serviceability of the structure.

Supports for fabric reinforcement are provided to prevent the fabric distorting when workers walk on top of it to place the concrete and maintain the correct concrete cover to the fabric.

PART 3.2.4 SITE CLASSIFICATION

3.2.4.1 Site classification

The *foundation* where the footing is to be located must be classified in accordance with AS 2870.

Explanatory information:

Table 3.2.4.1 provides a general description of *foundation* soil types that will assist in the classification of the *site*. More detailed information, including differentiation between classifications, can be found in AS 2870 or alternatively contact the *appropriate authority*.

Due to the limitations of this Part, if a *site* is classified as E or P then reference must be made to AS 2870 for design and construction information.

Explanatory information:

Table 3.2.4.1 GENERAL DEFINITION OF SITE CLASSES

Class	Foundation
A	Most sand and rock <i>sites</i> with little or no ground movement from moisture changes
S	Slightly reactive clay <i>sites</i> with only slight ground movement from moisture changes
M	Moderately reactive clay or silt <i>sites</i> which can experience moderate ground movement from moisture changes
H	Highly reactive clay <i>sites</i> which can experience high ground movement from moisture changes
E	Extremely reactive clay <i>sites</i> which can experience extreme ground movement from moisture changes
A to P	Filled <i>sites</i> —see AS 2870
P	<i>Sites</i> which include soft soils, such as soft clay or silt or loose sands; landslip; mine subsidence; collapsing soils; soils subject to erosion; reactive <i>sites</i> subject to abnormal moisture conditions or <i>sites</i> which cannot be classified otherwise

Note: For classes M, H and E further division based on the depth of the expected movement is *required*. For deep-seated movements, characteristic of dry climates and corresponding to a design depth of suction change H_s , equal to or greater than 3 m, the classification shall be M-D, H-D or E-D as appropriate. For example, H-D represents a highly reactive *site* with deep moisture changes, and H represents a highly reactive *site* with shallow moisture changes.

PART 3.2.5 FOOTING AND SLAB CONSTRUCTION

Explanatory information:

The footings included in this Part reflect the requirements of AS 2870 and apply to the most common types of soil conditions. If the soil conditions on *site* are not covered by this Part then additional guidance can be obtained from AS 2870 or the *appropriate authority*.

These provisions are not meant to prohibit the use of alternative traditional footing methods found through experience to be suitable for local soil conditions (especially those used in stable soils). Such footings may be appropriate, provided they meet the relevant *Performance Requirements* listed in [Section 2](#).

The diagrams in this Part reflect acceptable footing designs only. They do not provide details for termite barriers such as the correct placement of ant capping and slab edge exposure.

For details on termite barriers see [Part 3.1.3](#).

3.2.5.1 Footing and slab construction

- (a) Footing and slab construction, including size and placement of reinforcement, must comply with the relevant provisions of this Part and the following details:
 - (i) Footings for stumps—the appropriate details in [3.2.5.6](#) and [Table 3.2.5.2](#).
 - (ii) Stiffened raft Class A, S, M, M-D, H and H-D *sites*—the appropriate details in [Figure 3.2.5.3\(a\)](#) and [Figure 3.2.5.3\(b\)](#).
 - (iii) Strip footing systems in Class A, S, M, M-D and H *sites*—the appropriate details in [Figure 3.2.5.4\(a\)](#) and [Figure 3.2.5.4\(b\)](#).
 - (iv) Footing slabs for Class A *sites*—the appropriate details in [Figure 3.2.5.5](#).
- (b) Footings for *single leaf masonry*, *mixed construction* and *earth wall masonry* must comply with the equivalent footing construction set out in [Table 3.2.5.1](#).

3.2.5.2 Footings and slabs to extensions to existing buildings

- (a) Footings to extensions to Class 1 or 10 buildings may be of similar proportions and details to those used with an existing same Class of building on the same allotment provided—
 - (i) masonry and masonry veneer walls are articulated at the junction with the existing building; and
 - (ii) the performance of the existing building has been satisfactory, ie there has been no significant cracking or movement (see Section 2 of AS 2870 for acceptable footing performance); and
 - (iii) there are no unusual moisture conditions on the *site*.
- (b) Class 10 buildings of *clad framed* construction may use footing systems appropriate for one class of reactivity less severe than for a house.
eg: Site classification M can be reduced to S.

Table 3.2.5.1 EQUIVALENT FOOTING CONSTRUCTION

Actual construction			Equivalent footing construction (see Figure 3.2.5.2 to 5)
External walls		Internal walls	
Single leaf masonry			
	Reinforced <i>single leaf masonry</i>	<i>Articulated masonry</i> on Class A and S sites; or framed	<i>Articulated masonry veneer</i>
	Reinforced <i>single leaf masonry</i>	<i>Articulated masonry</i> or reinforced <i>single leaf masonry</i>	Masonry veneer
	<i>Articulated single leaf masonry</i>	<i>Articulated masonry</i>	Articulated full masonry
Mixed construction			
	Full masonry	Framed	Articulated full masonry
	Articulated full masonry	Framed	Masonry veneer
Earth wall masonry			
	Infill panels of earth masonry	Framed earth masonry	<i>Articulated masonry veneer</i>
	<i>Loadbearing earth masonry</i>	<i>Loadbearing earth masonry</i>	Articulated full masonry

3.2.5.3 Shrinkage control

- (a) Where brittle floor coverings, such as ceramic tiles, are to be used over an area greater than 16 m², one of the following additional measures must be taken to control the effect of shrinkage cracking—
- (i) the amount of shrinkage reinforcement (steel reinforcement mesh in the slab panel) must be—
 - (A) increased to SL92 or equivalent throughout the affected slab area; or
 - (B) doubled with an additional sheet of slab mesh throughout the affected slab area; or
 - (ii) the bedding system for brittle coverings must be selected on the basis of the expected slab movement and the characteristics of the floor covering (including the use of expansion joints etc); or
 - (iii) the placement of floor covering must be delayed for not less than 3 months after the concrete has been placed.
- (b) At re-entrant or internal corners, two strips, minimum 2 m in length, of 3–L8TM or one strip of 3–L11TM (or 3-N12 bars) must be placed diagonally across the corner in accordance with [Figure 3.2.5.1](#).

Figure 3.2.5.1

REINFORCING AT RE-ENTRANT CORNERS

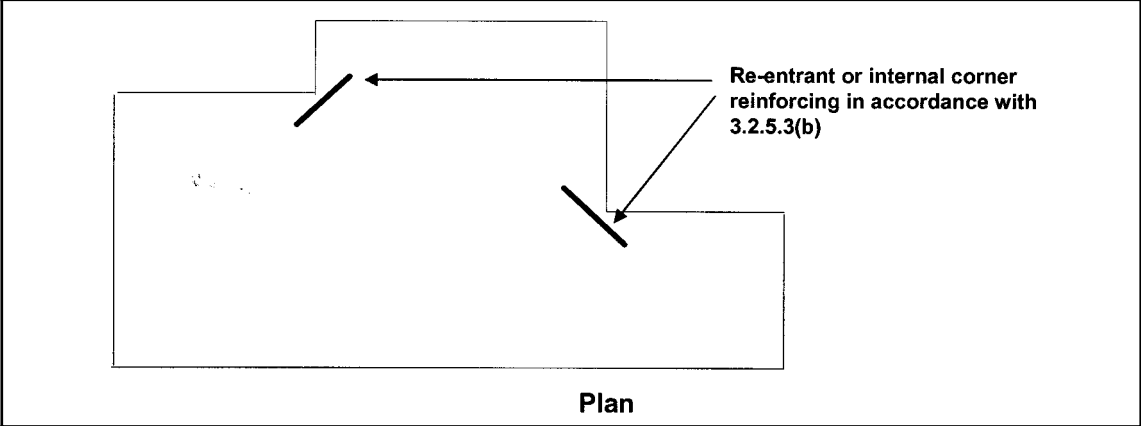

3.2.5.4 Minimum edge beam dimensions

Except for *waffle raft* slabs, where the edge rebate is more than 150 mm in depth, the width of the edge beam at the base of the rebate must not be less than 200 mm, except that if R10 or N10 ties at 900 mm spacing (or equivalent) are provided to resist vertical forces, the width of the edge beam at the base of the rebate can be reduced to 150 mm.

3.2.5.5 Footings for fireplaces on Class A and S sites

- (a) Fireplaces must be supported on a pad footing—
 - (i) 150 mm thick for single storey (one trafficable floor and a wall height not more than 4.2 m) construction; and
 - (ii) 200 mm thick for 2 storey (two trafficable floors and a wall height not more than 8 m) construction; and
 - (iii) reinforced top and bottom with SL72 mesh; and
 - (iv) extending 300 mm past the edges of the masonry except for any edge flush with the outer wall.
- (b) The pad footing may form an integral part of the slab.

3.2.5.6 Stump footing details

- (a) Footings for stumps must comply with—
 - (i) the provisions of [Table 3.2.5.2](#) for Class A and Class S sites; or
 - (ii) the appropriate acceptable construction manual listed in—
 - (A) [Part 3.4.3](#); or
 - (B) [3.2.0](#).
- (b) Concrete stumps must—
 - (i) be designed in accordance with—
 - (A) AS 3600; or

- (B) [Table 3.2.5.2](#); and
- (ii) use a minimum 20 MPa concrete as defined in AS 3600.
- (c) Steel stumps must be—
 - (i) designed in accordance with—
 - (A) AS 4100; or
 - (B) [Table 3.2.5.2](#); and
 - (ii) fully enclosed and sealed with a welded top plate; and
 - (iii) encased in concrete sloping away from the stump and finishing not less than 100 mm above *finished ground level*; and
 - (iv) corrosion protected in accordance with [Part 3.4.4](#).
- (d) Timber stumps must be designed in accordance with—
 - (i) AS 1684 Parts 2, 3 or 4; or
 - (ii) [Table 3.2.5.2](#).
- (e) Stumps must be braced—
 - (i) by a full perimeter masonry base; or
 - (ii) for concrete stumps—in accordance with AS 3600; or
 - (iii) for steel stumps—in accordance with AS 4100; or
 - (iv) for timber stumps—in accordance with AS 1684 Parts 2, 3 or 4.
- (f) Stumps must be embedded into the foundation material not less than 30% of their height above ground level or 450 mm, whichever is the greater.

Table 3.2.5.2 STUMP FOOTING—IN AREAS WITH A DESIGN WIND SPEED OF NOT MORE THAN W33

LENGTH OF STUMP (mm) (including embedded length)	CONCRETE		STEEL	TIMBER
	Minimum size (mm)	REINFORCEMENT Number of 5 mm (min.) hard drawn wires	Minimum size (mm) (SHS = square hollow section)	Minimum size (mm)
Less than 1400	100 × 100 or 110 diameter	1	75 × 75 × 2.0 SHS	100 × 100 or 110 diameter
1401–1800	100 × 100 or 110 diameter	2	75 × 75 × 2.0 SHS	100 × 100 or 110 diameter
1801–3000	125 × 125 or 140 diameter	2	75 × 75 × 2.0 SHS	100 × 100 or 110 diameter

Figure 3.2.5.2

PAD FOOTINGS FOR CLAD FRAME, CLASS A AND S SITES

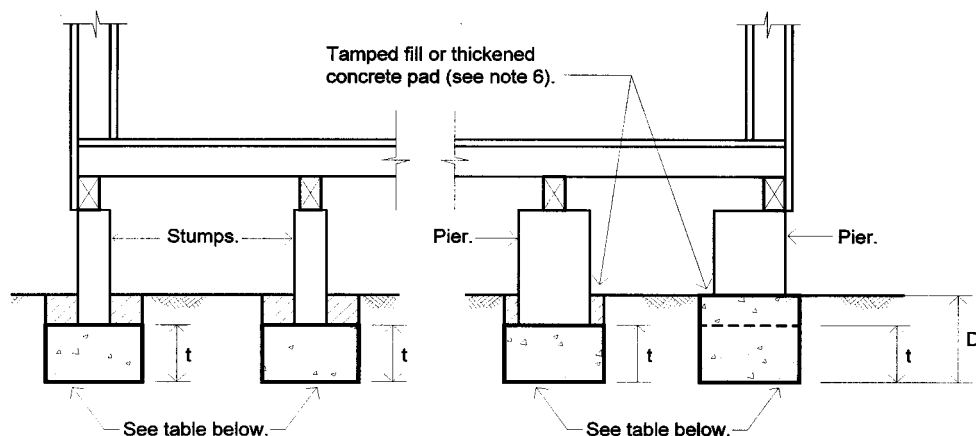

MINIMUM DIMENSIONS OF CIRCULAR AND SQUARE PAD FOOTINGS FOR CLAD FRAME CLASS A AND S SITES

Effective supported areas—m ²	Width of square pad—mm	Width of circular pad—mm	Thickness (t)—mm	Depth—mm
10	400	500	200	400
20	500	600	200	400
30	600	750	250	400

Notes:

1.	The effective area supported by a pad footing is the sum of—
(a)	the supported floor area; and
(b)	the supported roof area (if applicable); and
(c)	half the supported wall area in elevation (if applicable).
2.	The width or diameter can be reduced to one half the above footings on rock.
3.	The pad footings must be constructed in concrete except that masonry footings can be used under masonry piers.
4.	Pad footing sizes must also apply to footings supporting roof and floor loads only.
5.	The <i>foundation</i> must provide an allowable bearing pressure of not less than 100 kPa.
6.	The excavation must be backfilled with manually rodded tamped soil, or the footing thickness shall be increased by 50 mm.
7.	Where stump pad footings provide resistance to horizontal or uplift forces, the minimum size of the footing must comply with AS 2870.
8.	Braced stumps must comply with 3.2.5.6(e).

Figure 3.2.5.3(a)

FOOTING SLAB AND STIFFENED RAFT SLAB DETAILS FOR CLASS A AND S SITES

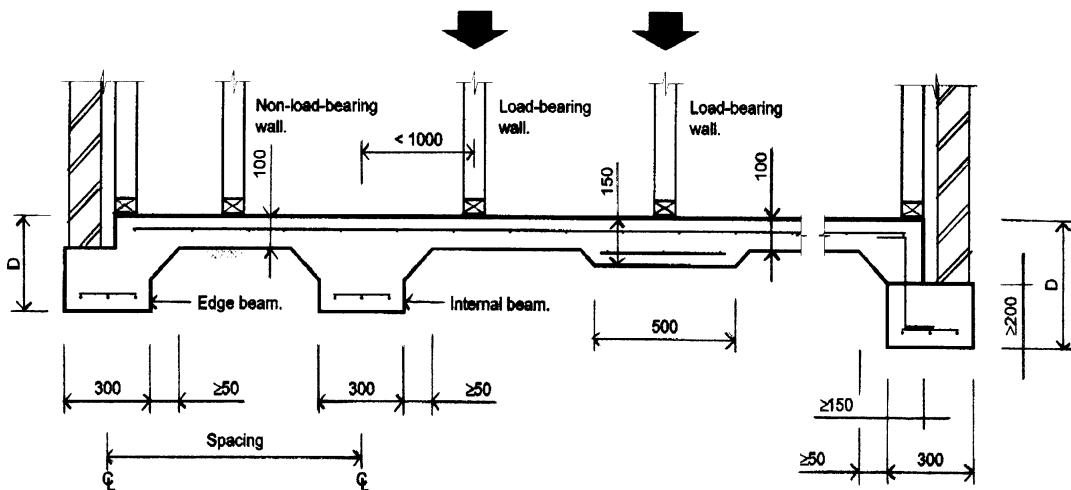

REINFORCEMENT FOR STIFFENED RAFT FOOTINGS

Slab Fabric

Site Class	Type of Construction	Depth (D) mm	Bottom reinf.	Max. spacing c/l to c/l (m)	Slab Fabric		
					Slab length <18 m	Slab length <25 m	Slab length <30 m
Class A	Clad Frame	300	3-L8TM	–	SL72	SL82	SL92
	Articulated masonry veneer	300	3-L8TM	–	SL72	SL82	SL92
	Masonry veneer	300	3-L8TM	–	SL72	SL82	SL92
	Articulated full masonry	400	3-L8TM	–	SL72	SL82	SL92
	Full masonry	400	3-L8TM	–	SL72	SL82	SL92
Class S	Clad Frame	300	3-L8TM	–	SL72	SL82	SL92
	Articulated masonry veneer	300	3-L8TM	–	SL72	SL82	SL92
	Masonry veneer	300	3-L11TM	–	SL72	SL82	SL92
	Articulated full masonry	400	3-L11TM	–	SL72	SL82	SL92
	Full masonry	450	3-L11TM	5.0*	SL82	SL82	SL92

Notes:

1. Internal and external edge beams must be arranged to form an integral structural grid (see Clauses 5.3.8 and 5.3.9 of AS 2870).
2. A 10% increase in spacings is permitted where the spacing in the other direction is 20% less than that specified.

Figure 3.2.5.3(a)

FOOTING SLAB AND STIFFENED RAFT SLAB DETAILS FOR CLASS A AND S SITES

3. Where external beams are wider than 300 mm, an extra bottom bar or equivalent of the same bar size is required for each 100 mm additional width.
4. Where a reinforced single leaf masonry wall is constructed directly above and structurally connected to a concrete edge beam, the beam may be reduced to 300 mm wide by 300 mm deep and reinforced with 3-L8TM reinforcement.
5. Alternative reinforcement sizes must comply with AS 2870.
6. Internal beam details and spacings shall comply with Figure 3.2.5.3. At a re-entrant corner where an external beam continues as an internal beam, the internal beam details shall be continued for a length of 1 m into the external beam.

* See Note 2.

Figure 3.2.5.3(b)

FOOTING SLAB AND STIFFENED RAFT SLAB DETAILS FOR CLASS M, M-D, H AND H-D SITES

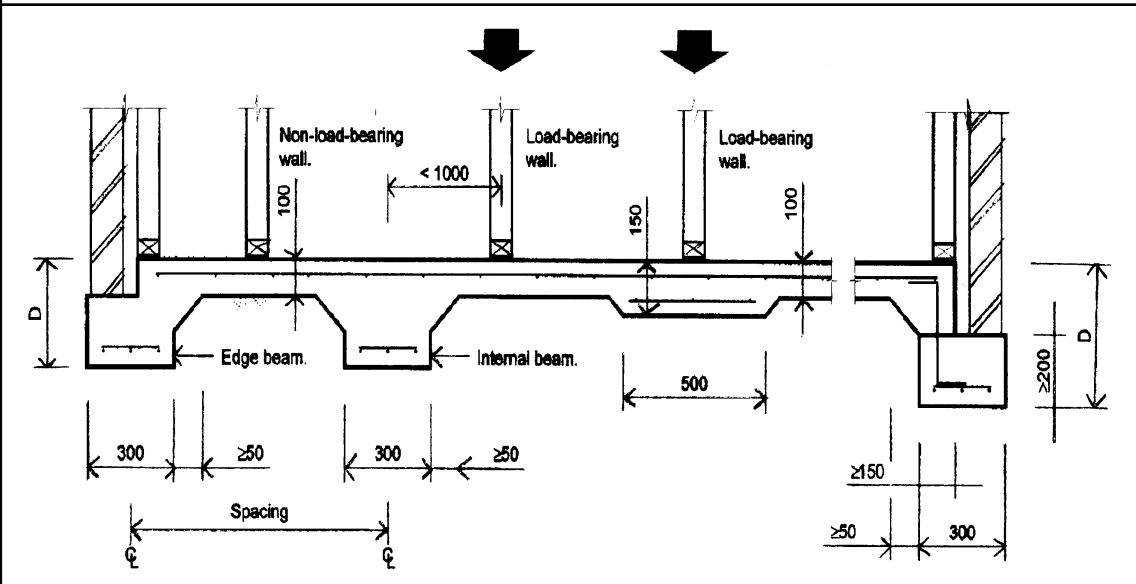

REINFORCEMENT FOR STIFFENED RAFT FOOTINGS					Slab Mesh		
Site Class	Type of Construction	Depth (D) mm	Bottom reinf.	Max. spacing c/l to c/l (m)	Slab length <18 m	Slab length <25 m	Slab length <30 m
Class M	Clad Frame	300	3-L11TM	6.0*	SL72	SL82	SL92
	Articulated masonry veneer	400	3-L11TM	6.0*	SL72	SL82	SL92
	Masonry veneer	400	3-L11TM	5.0*	SL72	SL82	SL92

Figure 3.2.5.3(b)							
FOOTING SLAB AND STIFFENED RAFT SLAB DETAILS FOR CLASS M, M-D, H AND H-D SITES							
	Articulated full masonry	500	3-L12TM	4.0	SL82	SL82	SL92
	Full masonry	800	3-N16	4.0	SL92	SL92	SL92
Class M-D	Clad Frame	400	3-L11TM	5.0*	SL72	SL82	SL92
	Articulated masonry veneer	400	3-L11TM	4.0	SL72	SL82	SL92
	Masonry veneer	500	3-L12TM	4.0	SL82	SL82	SL92
	Articulated full masonry	625	3-L12TM	4.0	SL92	SL92	SL92
	Full masonry	–	–	–	–	–	–
Class H	Clad Frame	400	3-L11TM	5.0*	SL72	SL82	SL92
	Articulated masonry veneer	500	3-L12TM	4.0	SL82	SL82	SL92
	Masonry veneer	700	3-N16	4.0	SL92	SL92	SL92
	Articulated full masonry	1000	4-N16	4.0	SL102	SL102	SL102
	Full masonry	–	–	–	–	–	–
Class H-D	Clad Frame	500	3-L11TM	4.0	SL82	SL82	SL92
	Articulated masonry veneer	600	3-L12TM	4.0	SL92	SL92	SL92
	Masonry veneer	–	–	–	–	–	–
	Articulated full masonry	1200	4-N16	4.0	SL102	SL102	SL102
	Full masonry	–	–	–	–	–	–

Figure 3.2.5.3(b)

FOOTING SLAB AND STIFFENED RAFT SLAB DETAILS FOR CLASS M, M-D, H AND H-D SITES

Notes:

1. Internal and external edge beams must be arranged to form an integral structural grid (see Clauses 5.3.8 and 5.3.9 of AS 2870).
2. A 10% increase in spacings is permitted where the spacing in the other direction is 20% less than that specified.
3. Where external beams are wider than 300 mm, an extra bottom bar or equivalent of the same bar size is required for each 100 mm additional width.
4. Where a reinforced single leaf masonry wall is constructed directly above and structurally connected to a concrete edge beam, the beam may be reduced to 300 mm wide by 300 mm deep and reinforced with 3–L8TM reinforcement.
5. Alternative reinforcement sizes must comply with AS 2870.
6. Internal beam details and spacings shall comply with Figure 3.2.5.3. At a re-entrant corner where an external beam continues as an internal beam, the internal beam details shall be continued for a length of 1 m into the external beam.

* See Note 2.

Figure 3.2.5.4(a)

STRIP FOOTING SYSTEMS IN CLASS A AND S SITES

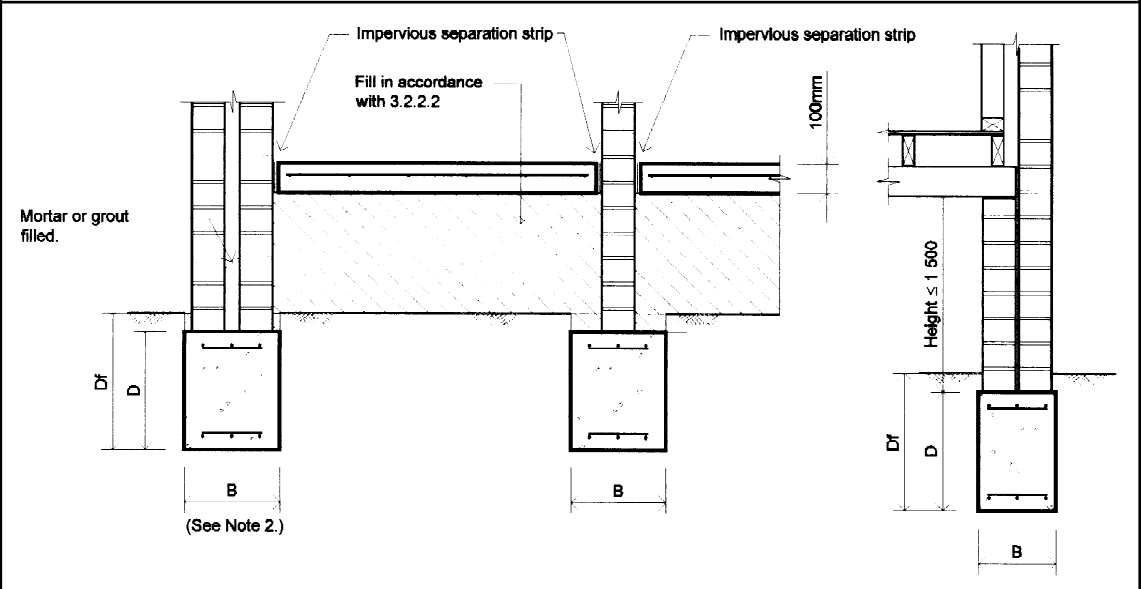

DIMENSIONS AND REINFORCEMENT FOR STRIP FOOTING SYSTEMS

Site Class	Type of construction	D	B	Reinforcement
Class A	Clad frame	300	300	3–L8TM
	Articulated masonry veneer	300	300	3–L8TM

Figure 3.2.5.4(a)				
STRIP FOOTING SYSTEMS IN CLASS A AND S SITES				
	Masonry veneer	300	300	3–L8TM
	Articulated full masonry	300	400	4–L8TM
	Full masonry	300	400	4–L8TM
Class S	Clad frame	400	300	3–L8TM
	Articulated masonry veneer	400	300	3–L8TM
	Masonry veneer	400	300	3–L8TM
	Articulated full masonry	400	400	4–L11TM
	Full masonry	500	400	4–L11TM
Notes:				
1.	All masonry walls must be supported on strip footings.			
2.	Internal strip footings shall be of the same proportions as the external footings and run from external footing to external footing. “Side slip joints” consisting of a double layer of polyethylene shall be provided at the sides of the footing only.			
3.	Infill floors may be concrete slabs, brick paving, stone flags or compacted and stabilised earth. For concrete slab infill panels, mesh may be required to control shrinkage in slab panels and around openings or restrained regions. Concrete infill slabs must use a minimum of SL62 mesh to control shrinkage (see also Clause 3.2.5.3).			
4.	Where footings are wider than the specified width, an extra bottom bar or equivalent of the same bar size is required for each 100 mm additional width. If strip footings deeper than those are required are used, the reinforcement shall be increased to match that specified for the deepened proportions.			
5.	The measurement of D_f is greater or equal to D plus 75 mm.			
6.	Alternative reinforcing sizes must comply with AS 2870.			
Figure 3.2.5.4(b)				
STRIP FOOTING SYSTEMS IN CLASS M, M-D AND H SITES				

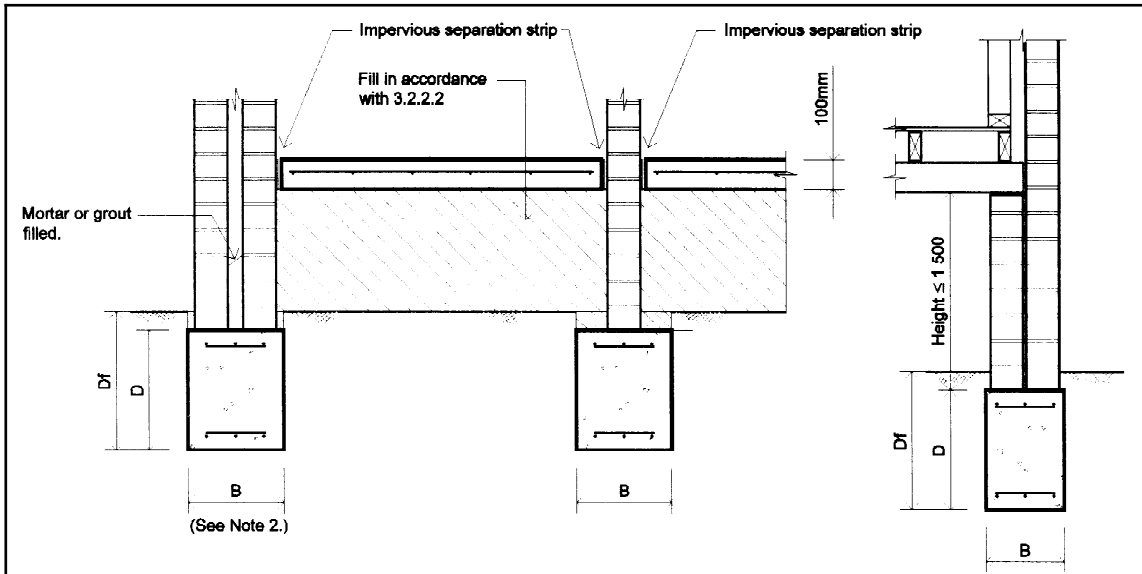

DIMENSIONS AND REINFORCEMENT FOR STRIP FOOTING SYSTEMS

Site Class	Type of construction	D	B	Reinforcement
Class M	Clad frame	400	300	3-L11TM
	Articulated masonry veneer	450	300	3-L11TM
	Masonry veneer	500	300	3-L12TM
	Articulated full masonry	600	400	4-L12TM
	Full masonry	900*	400	4-L12TM
Class M-D	Clad frame	500	300	3-L11TM
	Articulated masonry veneer	550	300	3-L12TM
	Masonry veneer	700*	300	3-N16
	Articulated full masonry	1100*	400	4-N16
Class H	Clad frame	500	300	3-L11TM
	Articulated masonry veneer	600	300	3-L12TM
	Masonry veneer	850*	300	3-N16
	Articulated full masonry	1100*	400	4-N16

Notes:

1. All masonry walls must be supported on strip footings.
2. For beams 700 mm or deeper, as specified in the table above, internal footings shall be provided at no more than 6 m centres and at re-entrant corners to continue footings to the opposite external footing. Internal strip footings shall be of the same proportions as the external footings and run from external footing to external footing. "Side slip joints" consisting of a double layer of polyethylene shall be provided at the sides of the footing only.
3. Infill floors shall only be used for Class A and S sites.

4.	Where footings are wider than the specified width, an extra bottom bar or equivalent of the same bar size is required for each 100 mm additional width. If strip footings deeper than those are required are used, the reinforcement shall be increased to match that specified for the deepened proportions.
5.	The measurement of D_f is greater or equal to D plus 75 mm.
6.	Alternative reinforcing sizes must comply with AS 2870.
7.	For Class M articulated full masonry and full masonry, internal strip footings must be of the same proportions as the external footing and run from external footing to external footing.
8.	For site classes M-D and H, a provision shall be made by methods such as an adequate crawl space to allow for future re-levelling due to drying effects.
* See Note 2.	

Figure 3.2.5.5

FOOTING SLABS FOR CLASS A SITES SUITABLE FOR:

(a)	CLAD FRAME.
(b)	ARTICULATED MASONRY VENEER.
(c)	MASONRY VENEER.
(d)	ARTICULATED FULL MASONRY.
(e)	FULL MASONRY.

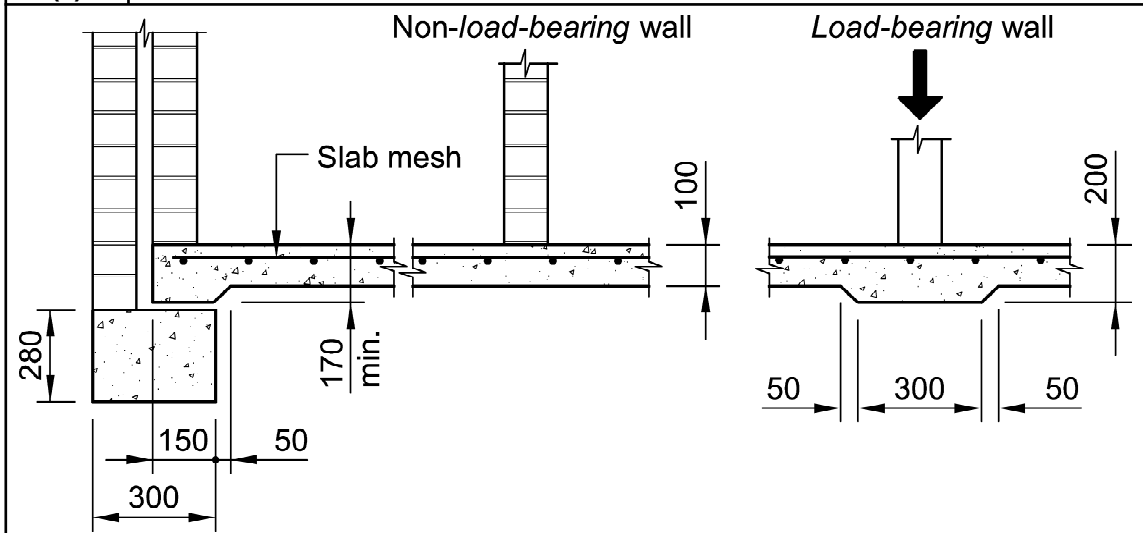

Notes:

1.	Use SL63 when slab length is less than 12 m.
2.	Use SL62 when slab length is less than 18 m.
3.	Use SL72 when slab length is less than 25 m.
4.	Use SL82 when slab length is less than 30 m.
5.	In parts of Western Australia (around Perth) and other locations where the <i>site</i> consists of extremely stable sands, and where specified by a <i>professional engineer</i> , the slab thickness may be reduced to 85 mm and reinforced as follows:

Figure 3.2.5.5

FOOTING SLABS FOR CLASS A SITES SUITABLE FOR:

(a)	CLAD FRAME.
(b)	ARTICULATED MASONRY VENEER.
(c)	MASONRY VENEER.
(d)	ARTICULATED FULL MASONRY.
(e)	FULL MASONRY.
(a)	Use SL53 when slab length is less than 12 m.
(b)	Use SL63 when slab length is less than 18 m.
(c)	Use SL62 when slab length is less than 25 m.
6.	Dune sands may require compaction.

PART **3.3**

MASONRY

3.3 Definitions

3.3.1 Unreinforce Masonry

3.3.2 Reinforced Masonry

3.3.3 Masonry Accessories

3.3.4 Weatherproofing of Masonry

PART 3.3 CONTENTS

PART 3.3 MASONRY

3.3 Definitions

3.3.1 Unreinforced Masonry

- 3.3.1.0 Acceptable construction manual
- 3.3.1.1 Application
- 3.3.1.2 External walls
- 3.3.1.3 Internal walls
- 3.3.1.4 Isolated piers
- 3.3.1.5 Masonry units
- 3.3.1.6 Mortar mixes
- 3.3.1.7 Mortar joints
- 3.3.1.8 Vertical articulation joints
- 3.3.1.9 Sub-floor ventilation
- 3.3.1.10 Shrinkage allowance for timber framing

3.3.2 Reinforced Masonry

- 3.3.2.0 Acceptable construction manual
- 3.3.2.1 Application
- 3.3.2.2 External wall construction

3.3.3 Masonry Accessories

- 3.3.3.0 Acceptable construction manual
- 3.3.3.1 Application
- 3.3.3.2 Wall ties
- 3.3.3.3 Fixing straps and tie down systems
- 3.3.3.4 Lintels

3.3.4 Weatherproofing of Masonry

- 3.3.4 Application of this Part
- 3.3.4.0 Acceptable construction manual
- 3.3.4.1 Application
- 3.3.4.2 Width of cavity
- 3.3.4.3 Cavity ventilation and drainage
- 3.3.4.4 Damp-proof courses - materials
- 3.3.4.5 Damp-proof courses - installation
- 3.3.4.6 Flashings
- 3.3.4.7 Location of flashings
- 3.3.4.8 Flashings at the base of cavity walls
- 3.3.4.9 Sill and head flashing
- 3.3.4.10 Flashings at a roof abutting a wall
- 3.3.4.11 Chimney flashings
- 3.3.4.12 Weatherproofing for single skin masonry walls

3.3.5 Earthwall Construction

- 3.3.5 Definitions
 - 3.3.5.0 Acceptable construction manual
 - 3.3.5.1 Application
 - 3.3.5.2 General construction
 - 3.3.5.3 Minimum thickness of walls
 - 3.3.5.4 Weatherproofing

Definitions

3.3

The following definitions are used in this Part:

Bond beam means a reinforced concrete or masonry member which acts as a lintel or stiffening beam to the masonry.

Cavity means a void between 2 leaves of masonry, or in masonry veneer construction, a void between a leaf of masonry and the supporting frame.

Engaged pier means a pier bonded to a masonry wall by course bonding of masonry units or by masonry ties.

Lateral support means a support (including footing, buttress, cross wall, beam, floor or braced roof structure) that effectively restrains the wall or pier at right angles to the face of the wall or pier.

Perpend means a vertical joint between adjacent masonry units.

Reinforced masonry means masonry reinforced with steel reinforcement that is placed in a bed joint or grouted into a core to strengthen the masonry.

Unreinforced masonry means masonry that is not reinforced.

PART 3.3.1 UNREINFORCED MASONRY

Appropriate Performance Requirements

Where an alternative masonry walling system is proposed as an *Alternative Solution* to that described in Part 3.3.1, that proposal must comply with—

- (a) *Performance Requirement P2.1*; and
- (b) the relevant *Performance Requirements* determined in accordance with 1.0.10.

A. Acceptable construction manual

3.3.1.0

Performance Requirement P2.1 is satisfied for *unreinforced masonry* (including masonry-veneer) if it is designed and constructed in accordance with AS 3700 Masonry structures.

Explanatory information:

Composite construction: Design requirements for other materials that may be used in combination with masonry ie heavy steel support beams etc are described in [Part 3.11](#)—Structural design.

B. Acceptable construction practice

3.3.1.1 Application

Compliance with this part satisfies *Performance Requirement P2.1* for *unreinforced masonry*, provided—

- (a) the *unreinforced masonry* is constructed on footings that comply with [Part 3.2](#); and
- (b) the building is located in an area with a *design wind speed* of not more than W41; and
- (c) for earthquake design, the building is defined as a design category H1 or H2 domestic structure in accordance with AS 1170.4; and

Explanatory information:

1. This covers all *sites* except those identified by the site investigation as having soft soil (having a soil profile with more than 5 m of soft clay, loose sand, silt or uncontrolled fill) as defined by AS 1170.4.
2. For earthquake design H3, see AS 3700.

- (d) the building is not constructed in an *alpine area*; and
- (e) masonry accessories, including wall ties and lintels are installed in accordance with [Part 3.3.3](#).

3.3.1.2 External walls

- (a) Masonry veneer must comply with the relevant provisions of this Part and be constructed as follows:
 - (i) Bracing requirements—masonry veneer *external walls* must be tied to a *loadbearing* frame constructed in accordance with [Part 3.4](#).
 - (ii) Masonry veneer walls, *non-loadbearing*, must be constructed with a leaf of masonry not less than 90 mm wide.
- (b) *Cavity* masonry and solid masonry walls must comply with the relevant provisions of this Part and be constructed as follows:
 - (i) The height of the wall between *lateral supports* (floor or roof) must be not more than 3 m with the exception of a gable where the height to the ridge from a floor which serves as lateral support may be not more than 5 m (refer to [Figure 3.3.1.1](#)).
 - (ii) Masonry cross walls must be—
 - (A) not less than 2 m in length at not more than 9 m centres; and
 - (B) connected directly or by a floor or ceiling diaphragm to the wall being supported.
- (c) *Cavity* walls must be constructed of two leaves, with each leaf not less than 90 mm wide.

Explanatory information:

For minimum *cavity* widths for veneer and *cavity* masonry, see [3.3.4.2](#)

Figure 3.3.1.1

HEIGHT RESTRICTIONS FOR MASONRY WALLS INCLUDING GABLE ROOF

Note:

Flat ceilings may act as lateral support to walls.

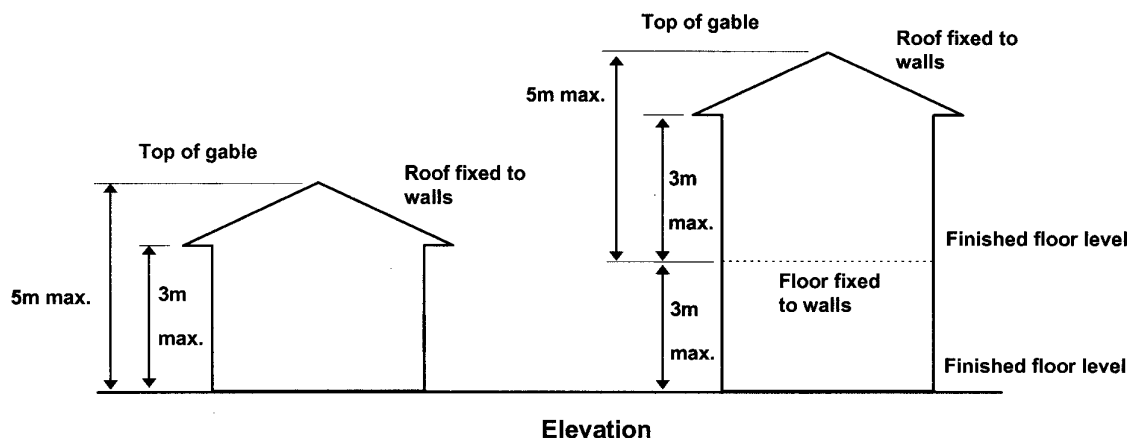

- (d) Unreinforced single leaf walls with *engaged piers* and return walls must comply with the relevant provisions of this Part and be constructed in accordance with the following:
- (i) The adjoining roof structure must be—
 - (A) connected to the *engaged piers*, (see [Figure 3.3.1.2](#)); or
 - (B) fixed to, or within 300 mm, of the return supports (see [Figure 3.3.1.3](#)).
 - (ii) Stack bonded piers must have wall ties at every 4th course.
 - (iii) Pier and return supports size limitations:
 - (A) Single-leaf *unreinforced masonry* walls with *engaged piers* must comply with [Figure 3.3.1.2](#).
 - (B) Single-leaf *unreinforced masonry* walls with return supports must comply with [Figure 3.3.1.3](#).
 - (iv) There must not be more than one opening per wall panel, and any opening must not be more than 900 mm high × 600 mm wide (see [Figure 3.3.1.3](#)).
 - (v) An *engaged pier* or return wall, must be provided at both sides of a door or full height window opening (see [Figure 3.3.1.2](#)).
 - (vi) Articulation joints must be located within 300 mm of vertical supports (see [3.3.1.8](#)).

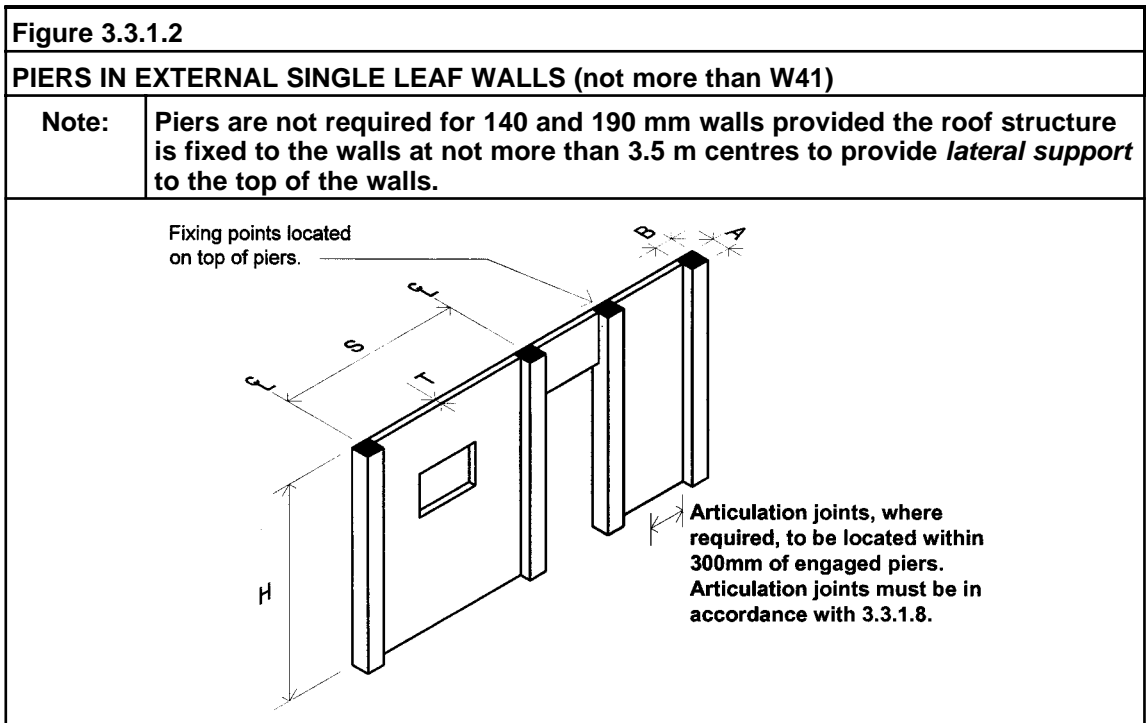

Table a. (Dimensions in mm)

Thickness of wall (min.)		T	90	110	140	190
Pier size (min.)	Not more than W33	AxB	290x190	350x230	–	–
	Not more than W41	AxB	290x290*	350x350*	–	–

Figure 3.3.1.2					
PIERS IN EXTERNAL SINGLE LEAF WALLS (not more than W41)					
Note:	Piers are not required for 140 and 190 mm walls provided the roof structure is fixed to the walls at not more than 3.5 m centres to provide <i>lateral support</i> to the top of the walls.				
Spacing of piers (max.)	S	1650	1800	–	–
Height (max.)	H	2400	2700	2400	2700
*	Piers in areas with a design wind speed of more than W33 must be vertically reinforced with at least 1/Y12, tied to the footing.				

- (e) A Class 10a building containing not more than 1 storey may be enclosed with masonry *external walls* not less than 110 mm in thickness, provided that—
- (i) the building measured in the direction of the span of the roof is not more than 9 m and the height is not more than 3 m; and
 - (ii) piers are formed that are not less than 230 mm wide, project not less than 120 mm and are spaced at not more than 3 m centres; and
 - (iii) the roof does not place any thrust onto the *external walls*; and
 - (iv) cross walls are constructed at not more than 9 m centres; and
 - (v) the Class 10a building is located in an area with a *design wind speed* of not more than W33; and
 - (vi) the building is a design category H1 domestic structure in accordance with AS 1170.4.

STATE AND TERRITORY VARIATIONS

3.3.1.2(e) does not apply in NSW.

Figure 3.3.1.3

RETURN SUPPORTS LIMITATIONS FOR EXTERNAL SINGLE-LEAF WALLS (for earthquake design category H1)

Note: Return supports are not required for 140 mm and 190 mm walls provided the roof structure is fixed at not more than 3.5 m centres to provide *lateral support* to the top of the walls.

Fixing points and articulation joints, where required, to be located within 300 mm of return walls. Articulation joints must be in accordance with 3.3.1.8.

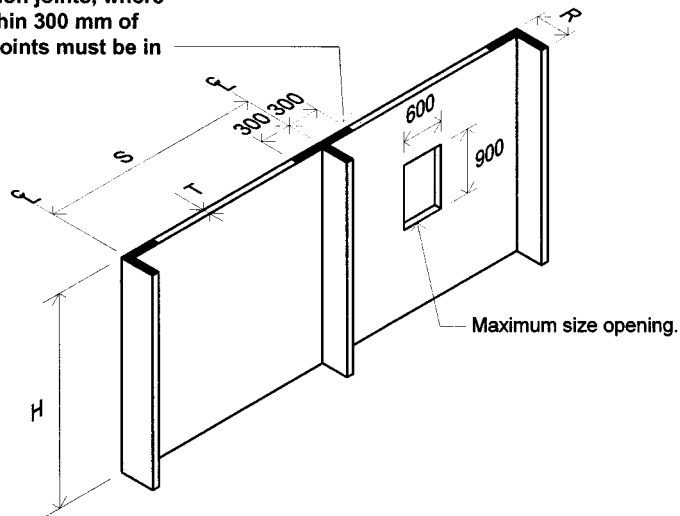

Table a. (Dimensions in mm)

Thickness of wall (min.)	T	90	110	140	190
Return length (min.)	R	450	450	–	–
Spacing of returns (max.)	S	3000 (W33)	3700 (W33)	–	–
		2500 (W41)	3000 (W41)		
Height (max.)	H	2400	2400	2400	2700

3.3.1.3 Internal walls

Internal masonry walls must comply with the relevant provisions of this Part and be constructed as follows:

- (a) Internal masonry walls must be not less than 75 mm thick.
- (b) Where wall junctions occur they must be bonded or an articulation joint provided in accordance with 3.3.1.8.
- (c) Single leaf internal walls must be supported by either—
 - (i) the ceiling structure in accordance with Figure 3.3.1.4(a); or
 - (ii) return walls in accordance with Figure 3.3.1.4(b). A full height door frame or stud fastened at the ceiling framing and tied to the wall at 300 mm centres can be considered equivalent to a return wall.

Figure 3.3.1.4

SUPPORT FOR INTERNAL WALLS (Dimensions in mm)

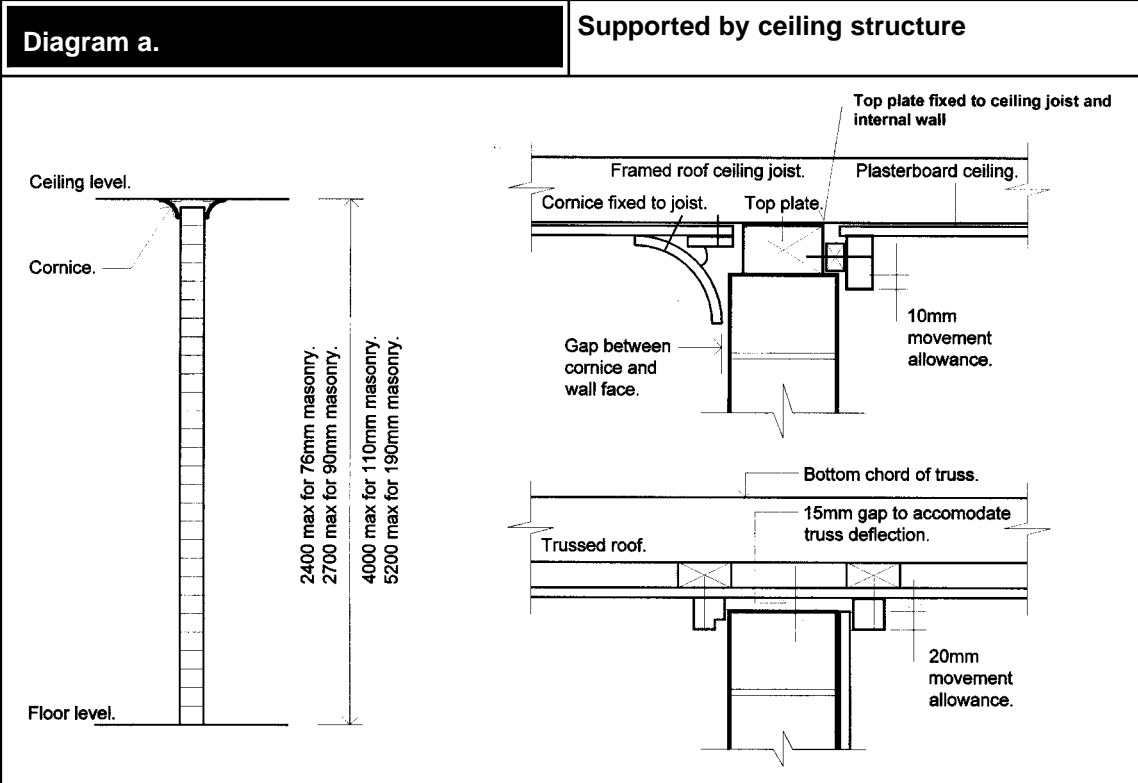
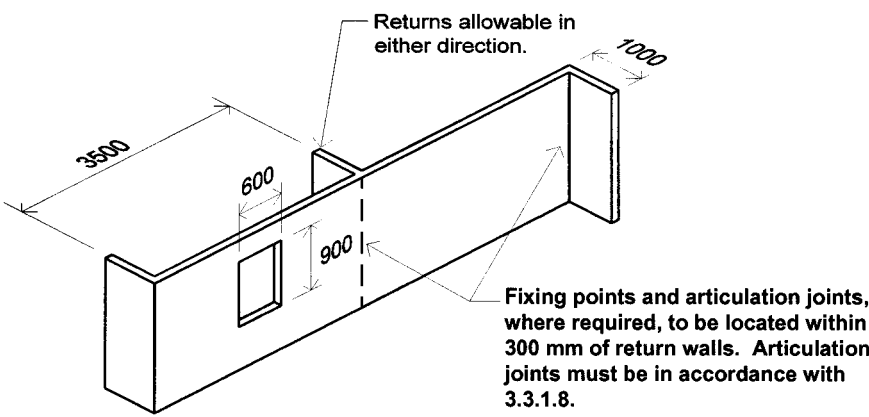

Figure 3.3.1.4	
SUPPORT FOR INTERNAL WALLS (Dimensions in mm)	
Diagram b.	Supported by return walls
Note:	
1.	An opening of not more than 600x900 mm is allowed to internal walls; and
2.	The maximum allowable height for the wall is described in Diagram a.
	

3.3.1.4 Isolated piers

- (a) Isolated masonry piers supporting carports, verandahs, porches and similar roof structures, which form part of the main roof, or are attached to a wall of a Class 1 building must be not less than 290×290 mm and—
- (i) must be not more than 2.7 m high (see [Figure 3.3.1.5](#)); and
 - (ii) must be spaced at not more than 3 m centres (see [Figure 3.3.1.5](#)); and
 - (iii) must comply with the relevant parts of [\(b\)](#), [\(c\)](#) or [\(d\)](#); and
 - (iv) may also support a roller door.
- (b) Isolated piers supporting tiled roofs
- Isolated piers supporting tiled roofs must have a built-in 32×0.8 mm galvanised steel strap fixed to the roof structure and looped around a 10 mm diameter galvanised steel rod built into the pier not less than six courses below the top of the pier.
- (c) Isolated piers supporting sheet roofs must have—
- (i) a built-in 32×0.8 mm galvanised steel strap fixed to the roof structure and extending the full height of the pier which is looped around a 10 mm diameter galvanised steel rod cast into the footing when poured; or
 - (ii) a 10 mm diameter galvanised steel rod cast into the footing, threaded at the top and extending the full height of the pier.
- (d) Piers for a free standing carport must—

- (i) be not less than 290×290 mm with the central core filled with 20 MPa concrete, or an exposure class mortar (see [Table 3.3.1.2](#)) complying with 3.3.1.6; and
 - (ii) have the core reinforced with 1 Y12 steel reinforcing rod cast into the footing and extending the full height of the pier to connect to the roof structure.
- (e) Sub-floor isolated piers must comply with [Figure 3.3.1.6](#).

**Figure 3.3.1.5
ISOLATED PIERS UNDER MAIN ROOF**

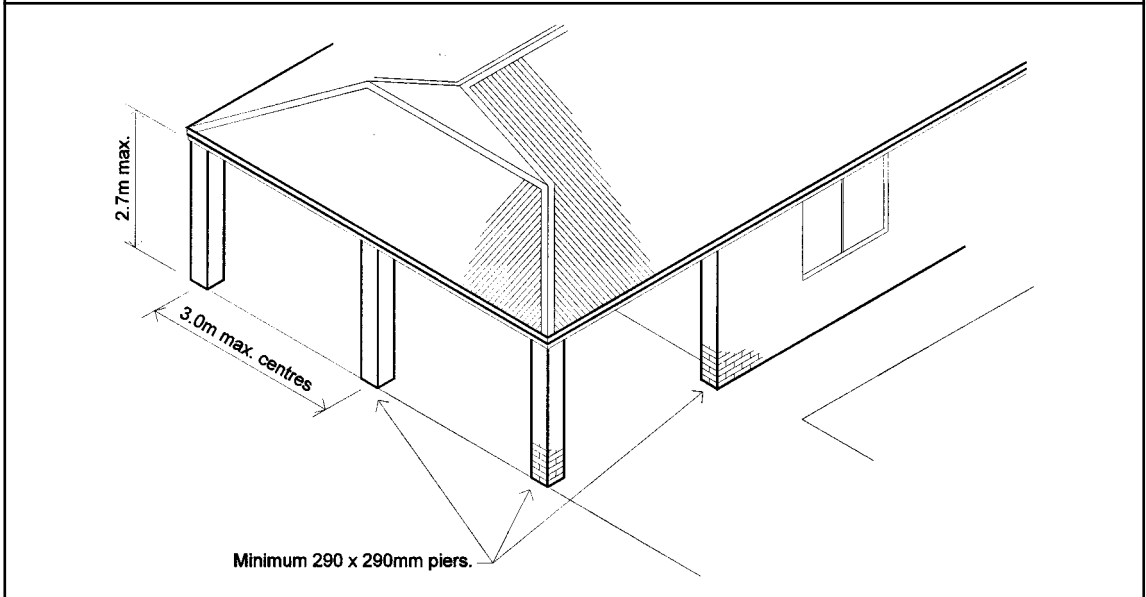

**Figure 3.3.1.6
SUB-FLOOR ISOLATED PIERS—MAXIMUM HEIGHTS**

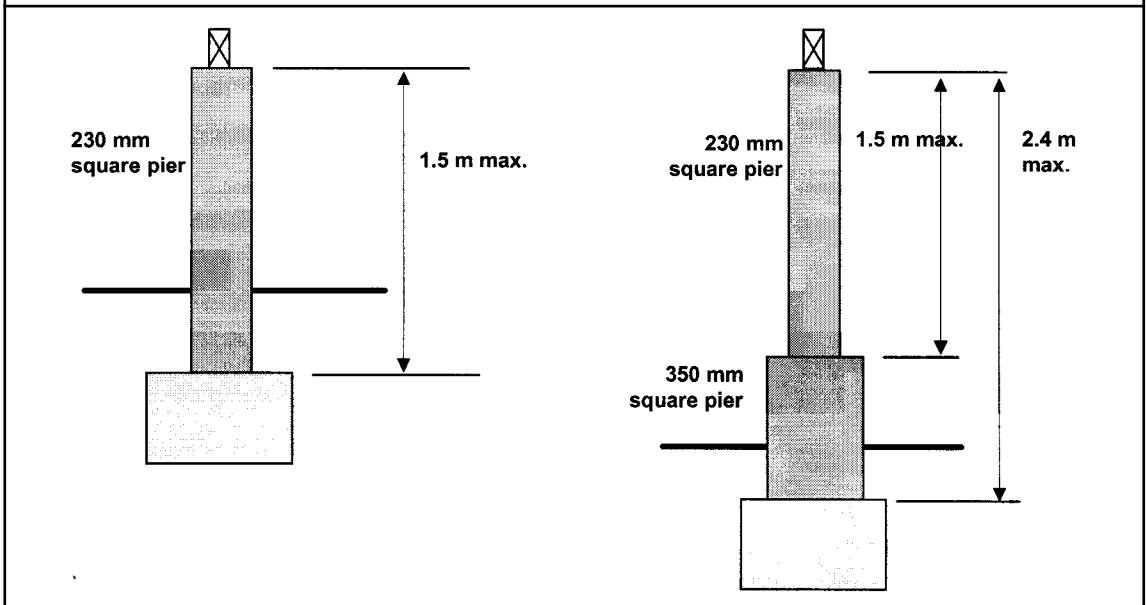

3.3.1.5 Masonry units

- (a) Mixing of clay with concrete or calcium silicate masonry panels for walling is not permitted; unless—
- (i) at vertical junctions, a control joint is installed; and
 - (ii) at horizontal junctions, a slip joint using a membrane similar to that used for *damp-proof courses* is installed between the panels of the two different materials.
- (b) Masonry units must be classified and used in the exposure conditions appropriate to their classification as described in [Table 3.3.1.1](#).

Table 3.3.1.1 EXPOSURE CONDITIONS

CLASSIFICATION	APPLICATION	
Protected (PRO)	Suitable for use above <i>damp-proof course</i> provided they are protected at the top of the wall by appropriate roofs, eaves, copings or toppings in—	
	(a)	internal walls; and
	(b)	coated or rendered <i>external walls</i>
General purpose (GP)	Suitable for all uses except exposure class	
Exposure Class (EXP)	Suitable for use in all classifications including severe local conditions such as:	
	(a)	Below the <i>damp-proof course</i> in areas where walls are expected to be attacked by salts in the ground water or brickwork itself (salt attack or salt damp).
	(b)	On sea fronts where walls are exposed to attack from salt spray, or in heavily polluted areas subject to deposition of atmospheric pollution (further protection may be required in severe environments).
	(c)	In retaining walls.
	(d)	Under regular cyclic freeze and thaw conditions.

3.3.1.6 Mortar mixes

Mortar used for masonry construction must—

- (a) comply with AS 3700; and
- (b) be mixed by volume in the proportions stated in [Table 3.3.1.2](#); and

- (c) contain fine aggregate sand with low clay content and free from efflorescing salts; and
- (d) contain water which is potable (drinkable).

Table 3.3.1.2 MORTAR MIXES

Note: Additives may be used provided they comply with the appropriate specified rate.		
BRICK CLASSIFICATION (as per Table 3.3.1.1)	MORTAR MIXED BY VOLUME Cement: Lime: Sand	
	General use	Suitable for concrete masonry—requires the use of methyl cellulose water thickener
Protected	1:2:9	1:0:5
General purpose	1:1:6	1:0:5
Exposure class	1:0.5:4.5	1:0:4

3.3.1.7 Mortar joints

- (a) Unless otherwise specified masonry bed and *perpend* joints are to be a nominal 10 mm.
- (b) Where raked joints are used they must not be—
 - (i) deeper than 10 mm; or
 - (ii) used in saline environments or areas subject to heavy industrial air-borne pollution.

3.3.1.8 Vertical articulation joints

- (a) Vertical articulation joints must be provided in *unreinforced masonry* walls except walls built where the *site* soil classification is A or S (see [Part 3.2.4](#)).
- (b) Articulation joints must have a width not less than 10 mm and be provided (see [Figure 3.3.1.7](#))—
 - (i) in straight, continuous walls having no openings, at not more than 6 m centres and not closer than the height of the wall away from corners; and
 - (ii) where the height of the wall changes by more than 20%, at the position of change in height; and
 - (iii) where openings more than 900×900 mm occur, at not more than 5 m centres, and positioned in line with one edge of the opening; and
 - (iv) where walls change in thickness; and
 - (v) at control or construction joints in footing slabs; and
 - (vi) at junctions of walls constructed of different masonry materials; and
 - (vii) at deep chases (rebates) for service pipes.

Figure 3.3.1.7

TYPICAL VERTICAL ARTICULATION JOINT LOCATIONS

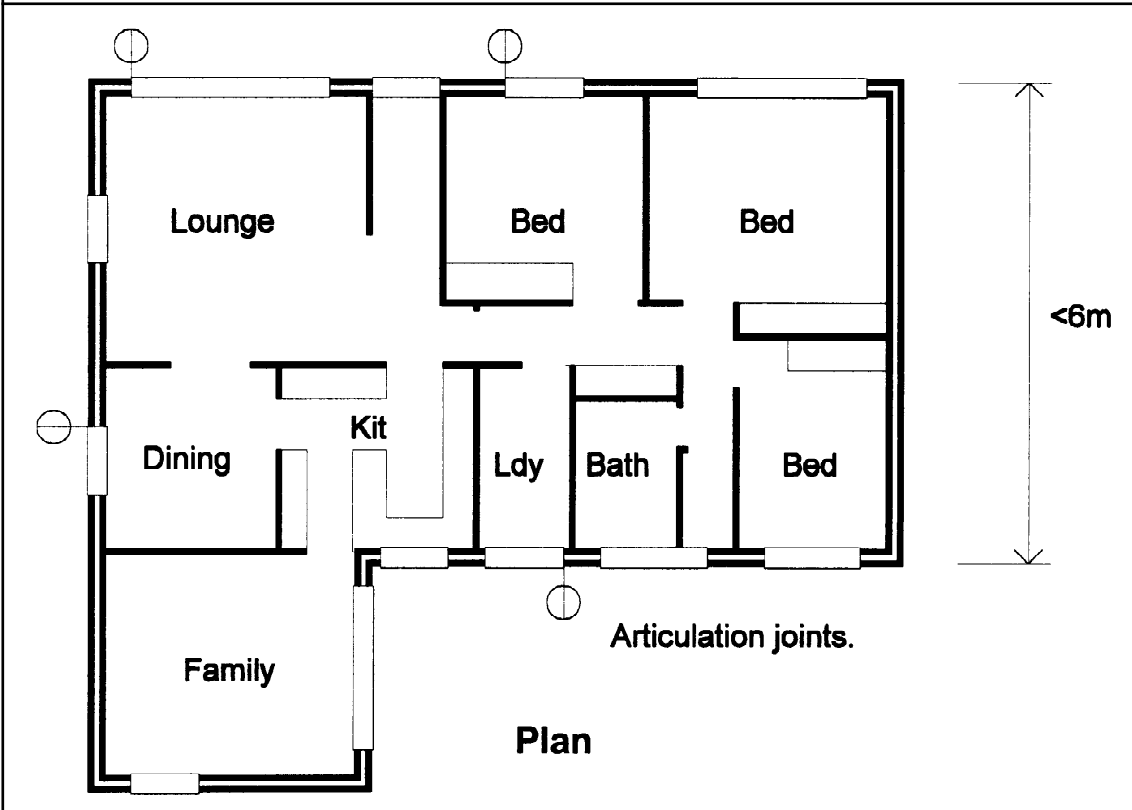

- (c) For all articulation joints in *cavity* walls, extendable masonry anchors must be built in at every fourth course (see [Figure 3.3.1.9](#)). For veneer construction the extendable ties may be omitted.
- (d) Where articulation joints are adjacent to door or window frames, a 10 mm gap must be left between the edge of the frame and the masonry to allow for movement (see [Figure 3.3.1.9](#)).
- (e) For single leaf masonry walls stabilised by return walls, or *engaged piers*, any articulation joints must be within 300 mm of the vertical support (see [Figures 3.3.1.3](#), and [3.3.1.4](#)).
- (f) All joints in single skin masonry must be sealed with a flexible, compressible material (see [Figure 3.3.1.9](#)).
- (g) Articulation joints constructed adjacent to arched openings must be constructed with minimum abutments between the opening and the articulation joint, in accordance with the Cement and Concrete Association of Australia—Technical Note 61.

Explanatory information: Design for other masonry wall types

The above design criteria are typical for clay masonry construction. Alternative designs may be appropriate and consideration should be given to a number of important factors to achieve an effective system, including—

- (a) expected soil movement—based on soil engineer’s report; and
- (b) expected masonry unit growth—based on manufacturer’s specifications; and

(c) construction of wall ie openings, length of wall, height.

For more detailed requirements of articulation joints, refer to the Cement and Concrete Association Construction Technical Note 61.

Figure 3.3.1.8

TYPICAL LOCATIONS FOR ARTICULATION JOINTS

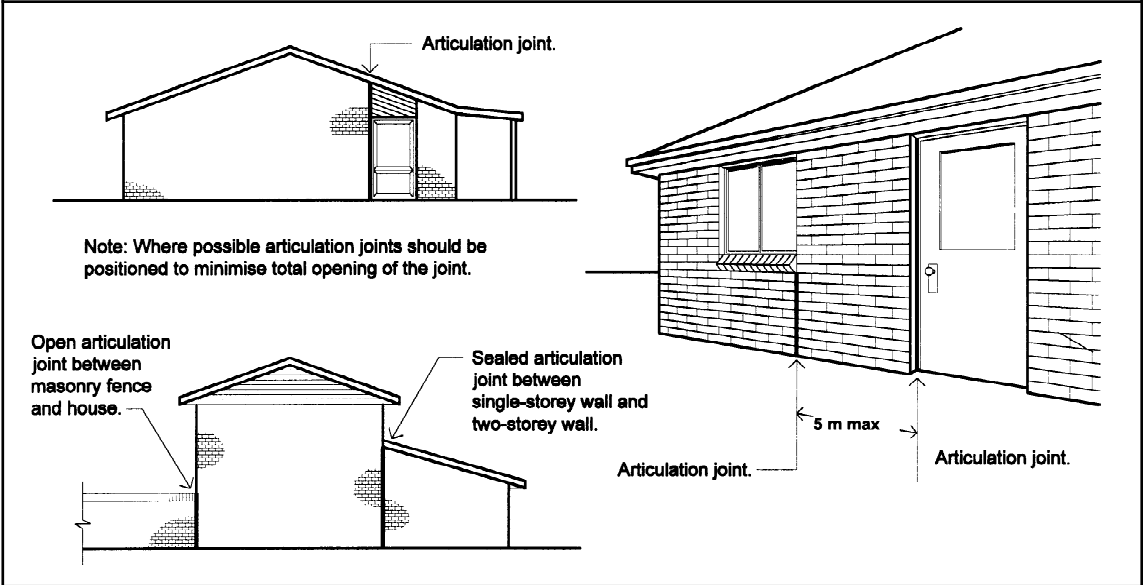
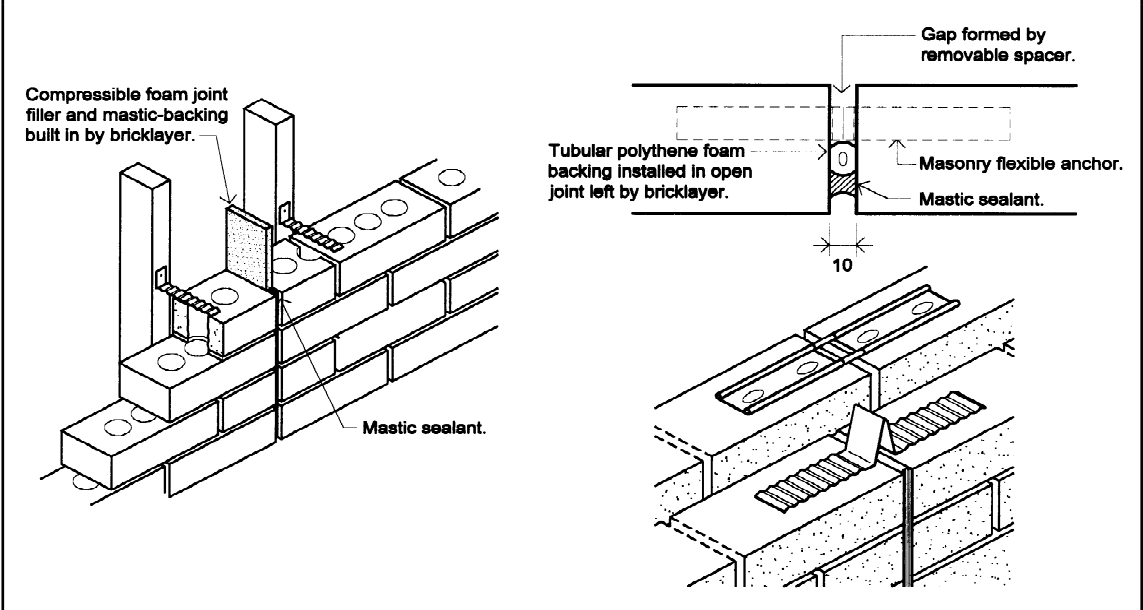

Figure 3.3.1.9

VERTICAL ARTICULATION JOINT DETAILS

Note:

Mastic sealant is optional in *cavity* brick construction.



3.3.1.9 Sub-floor ventilation

Ventilation under suspended floors must be in accordance with [Part 3.4.1](#).

3.3.1.10 Shrinkage allowance for timber framing

- (a) In masonry veneer walls a gap must be left between the timber frame and the top of the masonry wall, including *window* sills etc, to allow for settlement of the timber framing caused by timber shrinkage. These clearances must be not less than—
 - (i) 5 mm at sills or lower and single storey windows; and
 - (ii) 8 mm at roof overhangs of single storey buildings; and
 - (iii) 10 mm at sills of second storey windows; and
 - (iv) 12 mm at roof overhangs to two storey buildings.
- (b) The clearances described in (a) must be doubled if the timber framing is unseasoned hardwood.

PART 3.3.2 REINFORCED MASONRY

Appropriate Performance Requirements

Where an alternative *reinforced masonry* system is proposed as an *Alternative Solution* to that described in Part 3.3.2, that proposal must comply with—

- (a) *Performance Requirement P2.1*; and
- (b) the relevant *Performance Requirements* determined in accordance with **1.0.10**.

A. Acceptable construction manual

3.3.2.0

Performance Requirement P2.1 is satisfied for *reinforced masonry* if it is designed and constructed in accordance with AS 3700 Masonry Code.

Explanatory information:

Design requirements for other materials that may be used in combination with masonry (heavy steel support beams etc) are described in **Part 3.11**—Structural design.

B. Acceptable construction practice

3.3.2.1 Application

Compliance with this Part satisfies *Performance Requirement P2.1* for *reinforced masonry*, provided—

- (a) the *reinforced masonry* is constructed on footings that comply with **Part 3.2**; and
- (b) the building is located in an area with a *design wind speed* of not more than W41; and

Explanatory information:

1. Information on *design wind speeds* for particular areas may be obtained from the *appropriate authority*.
2. Masonry walls in an area with a *design wind speed* of more than W41 should be designed in accordance with AS 3700 or **Part 3.10.1**.

- (c) for earthquake design, the building is defined as a design category H1 or H2 domestic structure in accordance with AS 1170.4; and

Explanatory information:

1. This covers all *sites* except those identified by the site investigation as having soft soil (having a soil profile with more than 5 m of soft clay, loose sand, silt or uncontrolled fill) as defined by AS 1170.4.
2. For earthquake design H3, see AS 3700.

(d) the building is not constructed in an *alpine area*.

3.3.2.2 External wall construction

Reinforced masonry external walls must consist of masonry units complying with AS 3700 and constructed in accordance with the following (see also [Figure 3.3.2.1](#)):

- (a) The *external wall* thickness must not be less than 140 mm.
- (b) Tie down rods must be provided and be—
 - (i) not less than one Y12 steel reinforcing bar (or equivalent); and
 - (ii) spaced at not more than 1.8 m centres between openings; and
 - (iii) fully grouted into the block work with a grout having a characteristic compressive strength of 20 MPa; and
 - (iv) lapped with cogged steel starter bars of a size not less than the tie down rods, set 250 mm into the concrete edge beam or footing in accordance with [Figure 3.3.2.1](#).

Figure 3.3.2.1

TYPICAL FOOTING/TIE DOWN DETAILS

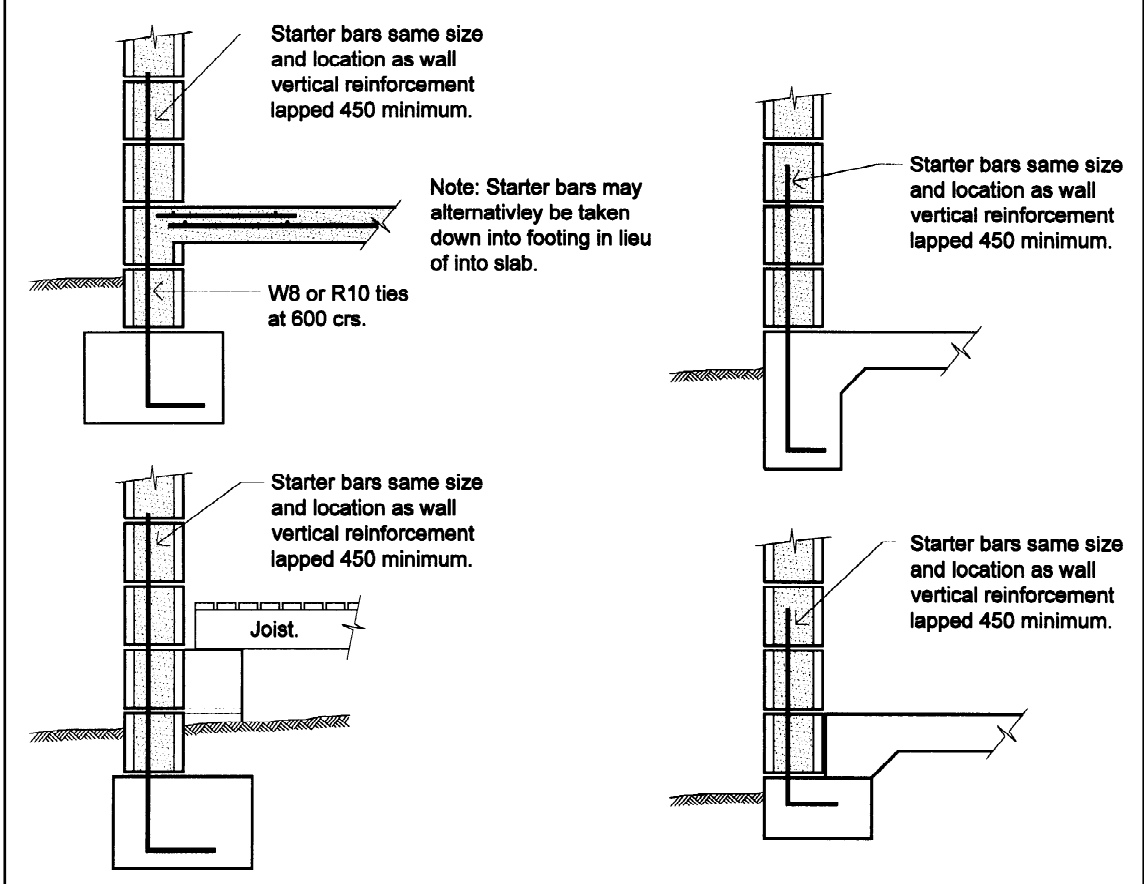

- (c) A continuous reinforced concrete *bond beam* must—
- (i) be installed at the top of the walls in accordance with [Figure 3.3.2.2](#) and [Figure 3.3.2.3](#); and
 - (ii) have not less than two Y12 bars set in concrete grout with a characteristic compressive strength of 20 MPa; and
 - (iii) at door and *window* openings the *bond beam* may serve as a lintel supporting the roof trusses, provided additional reinforcement is placed in accordance with [Figure 3.3.2.4](#); and
 - (iv) at first floor level a one course *bond beam* must be constructed in accordance with [Figure 3.3.2.2](#).
- (d) All cores in masonry hollow block work below ground level must be filled with concrete grout.

Figure 3.3.2.2

TYPICAL BOND BEAM DETAILS

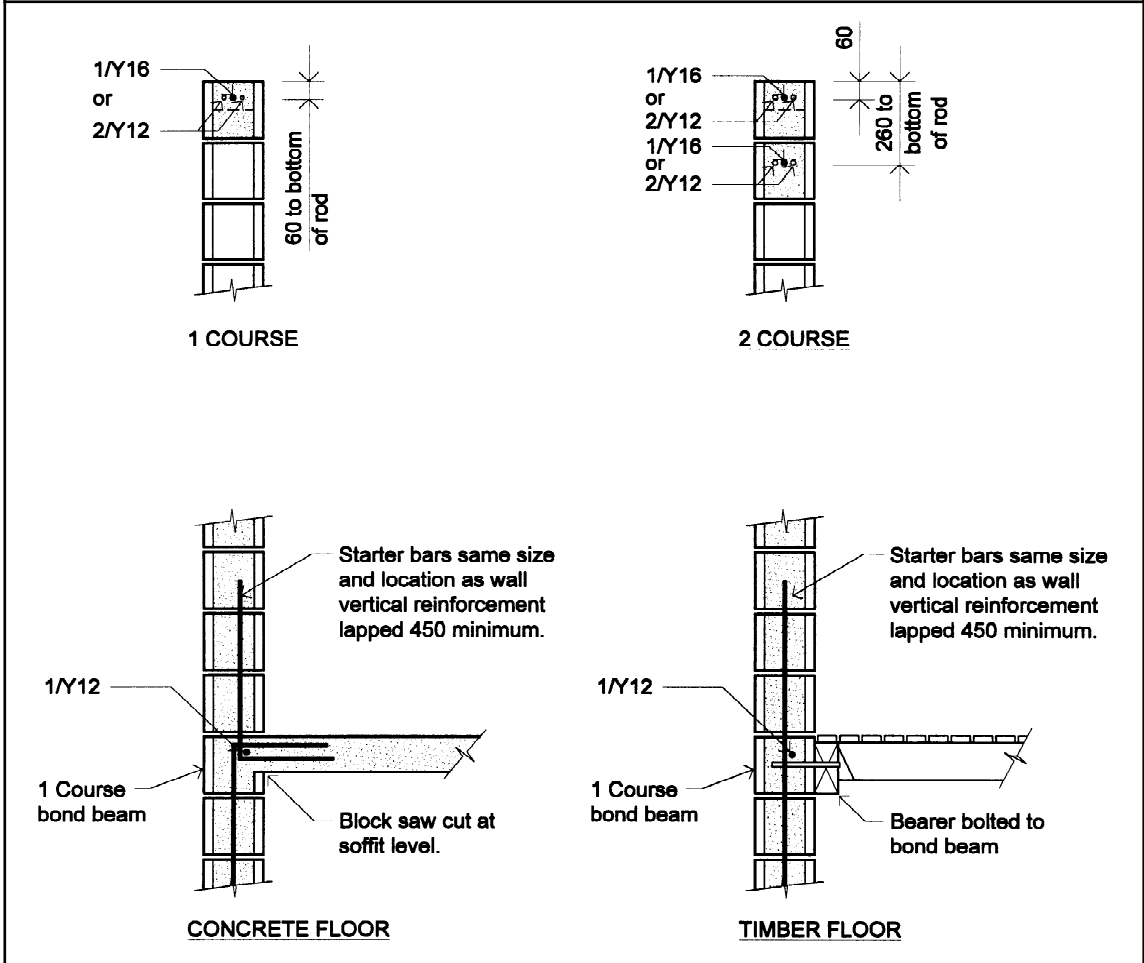

- (e) Lintels must be installed in accordance with the following:
- (i) Lintels must be supported on reinforced piers in accordance with [Table 3.3.2.1](#) (where appropriate).
 - (ii) Lintels carrying roof loads must be constructed in accordance with the appropriate requirements of [Figure 3.3.2.3](#) and [Figure 3.3.2.4](#).

Table 3.3.2.1

ADDITIONAL WALL PIER REINFORCING

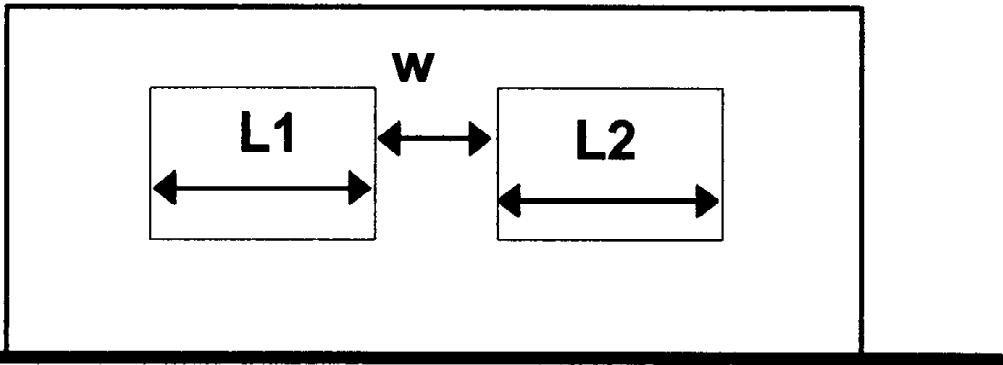

MAXIMUM SUM OF OPENINGS BESIDE PIERS "L1 + L2"

ALL CORES REINFORCED WITH ONE Y12 ROD			END CORES ONLY REINFORCED WITH Y12 ROD	
WIDTH OF PIER "W" (mm)			WIDTH OF PIER "W" (mm)	
200	400	600	600	800
4000	6000	6000	6000	6000

Figure 3.3.2.3

TYPICAL REINFORCED WALL

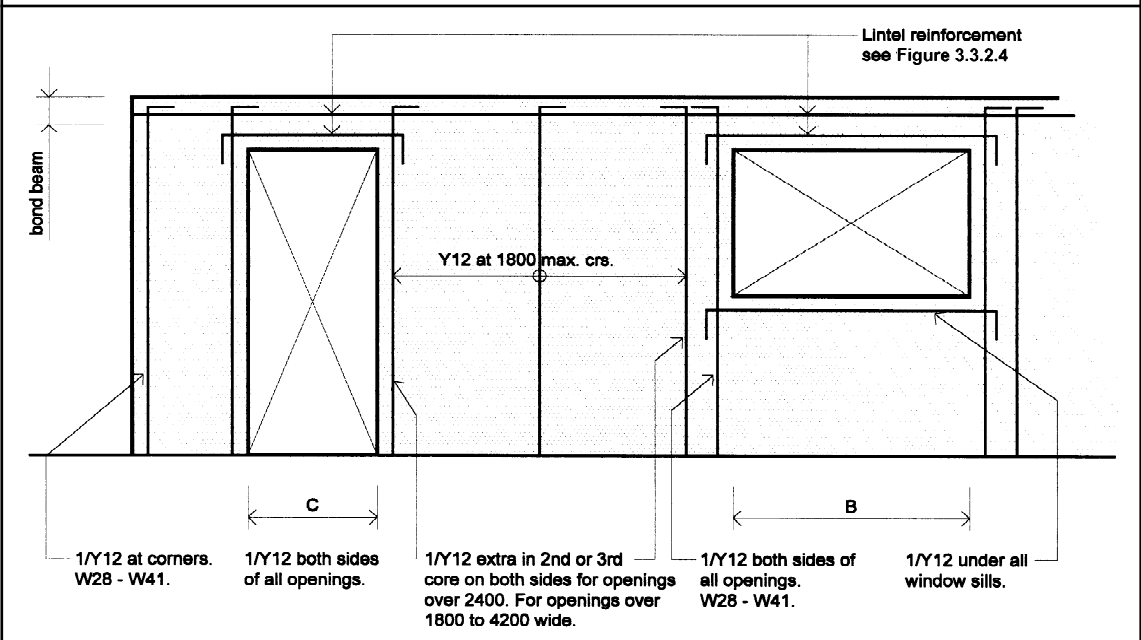

Figure 3.3.2.4

REINFORCEMENT AND CONSTRUCTION OF LINTELS

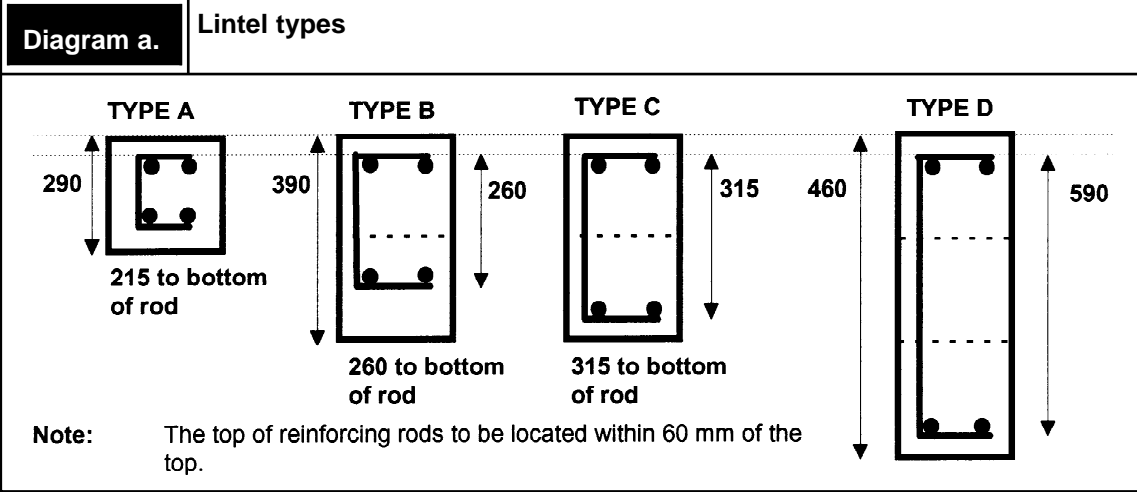

Table a. Reinforcement for lintel types

CODE				REINFORCEMENT	
A1	B1	C1	D1	2-Y12	Top and Bottom
A2	B2	C2	D2	1-Y16	Top and Bottom
A3S	B3S	C3S	D3S	2-Y12	Top and Bottom with W8 Stirrups @ 200 crs
A4S	B4S	C4S	D4S	1-Y16	Top and Bottom with W8 Stirrups @ 200 crs
A5	B5	C5	D5	2-Y16	Top and Bottom
A6S	B6S	C6S	D6S	2-Y16	Top and Bottom with W8 Stirrups @ 200 crs

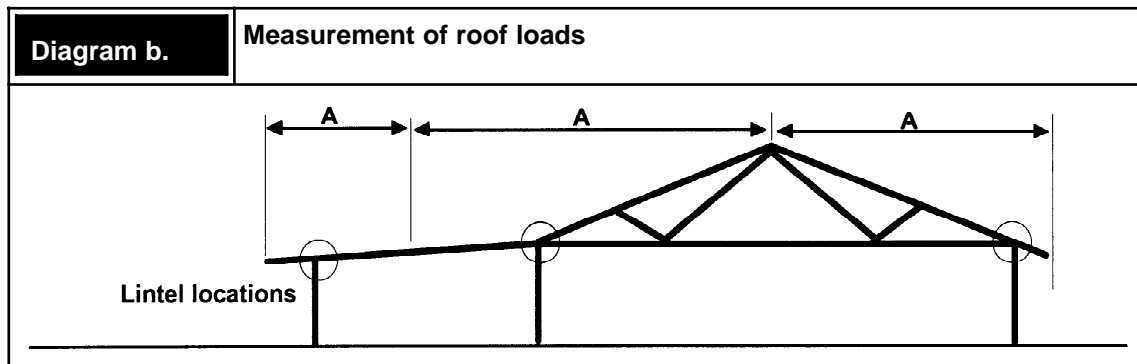

Table b. Lintel reinforcing for standard truss loading

Note:	In lintels and bond beams using 2/Y12 bars, 1/Y16 bar may be used instead								
OPENING	MINIMUM LINTEL REINFORCEMENT FOR STANDARD TRUSS LOADING								
(mm)	Maximum "A"–4.6 m			Maximum "A"–5.6 m			Maximum "A"–6.6 m		
	LINTEL DEPTH (mm)			LINTEL DEPTH (mm)			LINTEL DEPTH (mm)		
	300	400	600	300	400	600	300	400	600
900	A1	B1 OR C1	D212	A1	B1 OR C1	D1	A1	B1 OR C1	D1
1200	A1	B1 OR C1	D212	A1	B1 OR C1	D1	A1	B1 OR C1	D1
1800	A1	B1 OR C1	D212	A1	B1 OR C1	D1	A3S	B1 OR C1	D1
2400	A1	B1 OR C1	D212	A3S	B1 OR C1	D1	A6S	B3S OR C1	D1
3000	A6S	B3S OR C1	D5	A6S	B6S OR C5	D1		B6S OR C66	D1
3600	–	B3S OR C5	D5		B6S OR C6S	D1		– C6S	D5
4200	–	– C6S	D5		– C6S	D5			D6
4800	–	– C6S	D5			D6			D6

- (f) Bracing walls must be installed in buildings to control lateral loading in accordance with the following:
- (i) The walls must be constructed in accordance with [Figure 3.3.2.5](#).
 - (ii) The permissible bracing capacity is determined in accordance with [Table 3.3.2.2](#) after considering [Figure 3.3.2.6](#).

Figure 3.3.2.5

TYPICAL BRACING WALL DETAILS

90 AND 110 mm WALLS TIED TO EXTERNAL WALL

Maximum height of wall 2.7 m

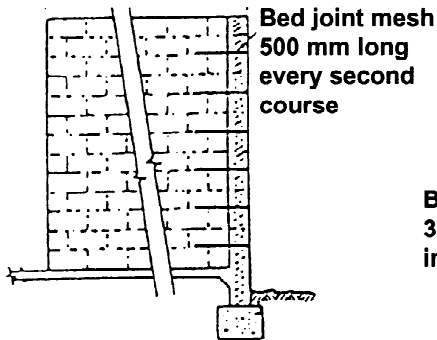

Bed joint mesh
500 mm long
every second
course

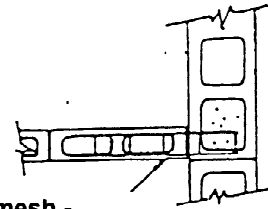

Bed joint mesh -
350 mm min into
internal wall

140 AND 190 mm WALLS TIED TO EXTERNAL WALL WITH OR WITHOUT TIE-DOWN INTO SLAB

Maximum height of wall 2.7 m

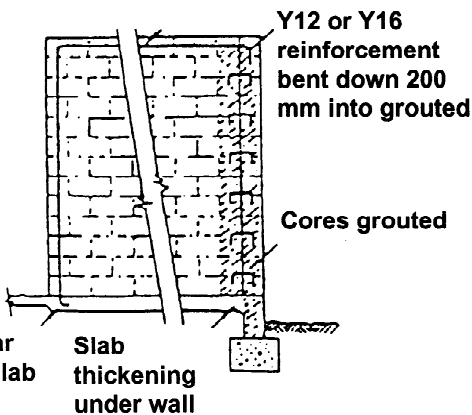

Y12 or Y16
reinforcement
bent down 200
mm into grouted

Cores grouted

1Y12 or Y15 starter bar
anchored down into slab

Slab
thickening
under wall

W8 ties every
second course bent
down 100 mm into
grouted core

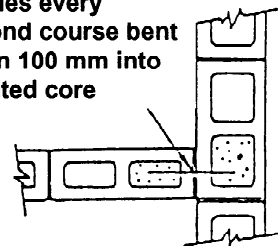

Figure 3.3.2.6

IDENTIFYING WALL LENGTHS—(To be used with [Table 3.3.2.2](#))

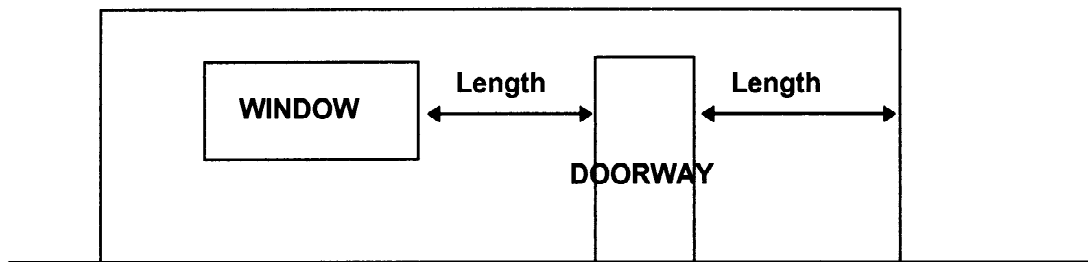

Table 3.3.2.2 BRACING CAPACITY OF WALLS 2.7 m HIGH

Note: Where a bracing wall is connected at only one end to a wall with a single course *bond beam*, the bracing value is limited by shear through the *bond beam* to 28.8 kN. Where it is necessary to use higher values a double *bond beam* must be used.

Wall Length (m)	PERMISSIBLE BRACING CAPACITY (kN)						
	90 mm & 110 mm Walls	140 mm Wall			190 mm Wall		
		No Tie down	Tie down size		No Tie down	Tie down size	
			Y12	Y16		Y12	Y16
0.4	–	–	2.4	4.1	0.1	2.4	4.2
0.6	–	0.1	4.1	6.7	0.2	4.1	7.4
0.8	0.2	0.3	5.8	7.8	0.3	6.0	10.0
1.0	0.4	0.5	7.6	9.0	0.6	7.8	11.2
1.2	0.5	0.7	9.5	10.0	0.8	9.7	12.4
2.4	2.1	2.8	16.8	16.8	3.3	19.6	19.6
3.0	3.3	4.4	20.2	20.2	5.2	23.2	23.2
3.6	4.8	6.3	23.5	23.5	7.4	26.8	26.8
4.2	6.6	8.6	26.9	26.9	10.2	30.4	30.4
4.8	8.6	11.2	30.2	30.2	13.3	34.0	34.0
5.4	10.5	14.2	33.6	33.6	16.8	37.6	37.6
6.0	10.5	17.6	37.0	37.0	20.7	40.4	40.4

- (g) Roof trusses must be tied to the *reinforced masonry* wall with a method appropriate to the design strength nominated in [Figure 3.3.2.7\(a\)](#) or [\(b\)](#) after taking into consideration—
- (i) the uplift force as determined in accordance with [Table 3.3.2.3](#); and
 - (ii) the net design uplift pressure as determined in accordance with AS 4055, AS 1170.2 or AS/NZS 1170.2.

Table 3.3.2.3 ROOF TRUSSES—UPLIFT FORCES

DESIGN WIND SPEED	NET DESIGN UPLIFT PRESSURE (kPa)		NET DESIGN UPLIFT FORCE ON STANDARD TRUSS (kN)								
			TRUSSES AT 600 mm SPACING			TRUSSES AT 900 mm SPACING					
			TILE ROOF			TILE ROOF			SHEET ROOF		
	TILE ROOF	SHEET ROOF	DIMENSION “A” (m)			DIMENSION “A” (m)			DIMENSION “A” (m)		
			4.6	5.6	6.6	4.6	5.6	6.6	4.6	5.6	6.6
W33	0.00	0.42	0.0	0.0	0.0	0.0	0.0	0.0	1.7	2.1	2.5
W41	0.44	0.81	1.2	1.5	1.7	1.8	2.2	2.6	3.4	4.1	4.8

Note:

DESIGN WIND SPEED	NET DESIGN UPLIFT PRESSURE (kPa)		NET DESIGN UPLIFT FORCE ON STANDARD TRUSS (kN)								
			TRUSSES AT 600 mm SPACING			TRUSSES AT 900 mm SPACING					
			TILE ROOF			TILE ROOF			SHEET ROOF		
	TILE ROOF	SHEET ROOF	DIMENSION "A" (m)			DIMENSION "A" (m)			DIMENSION "A" (m)		
			4.6	5.6	6.6	4.6	5.6	6.6	4.6	5.6	6.6

1. For a standard truss, the uplift force at each end is equal to the pressure multiplied by dimension "A" multiplied by the truss spacing.
2. Uplift forces for other values of dimension "A" may be interpolated.
3. Sheet roof includes metal tile.
4. Dimension "A" is determined in accordance with [Figure 3.3.2.4](#) Diagram b.

Figure 3.3.2.7(a)
TYPICAL TRUSS TIE DOWN METHODS USING THREADED ROD

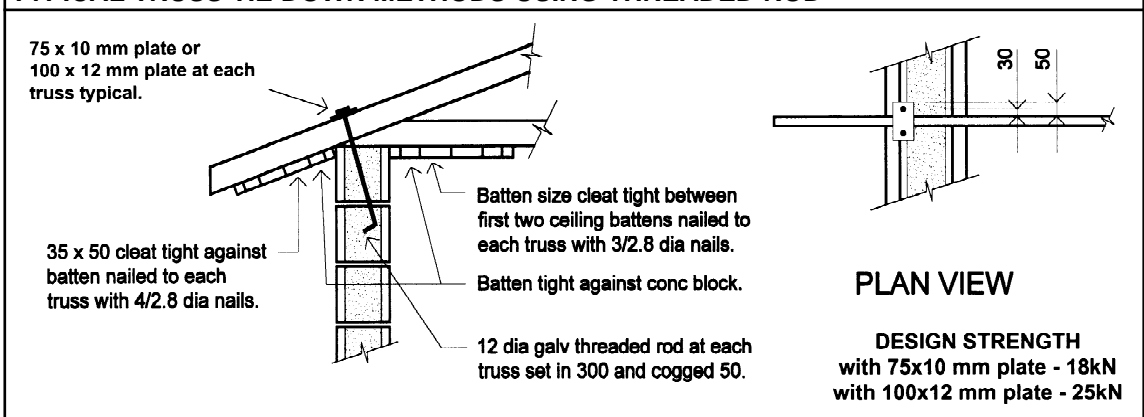
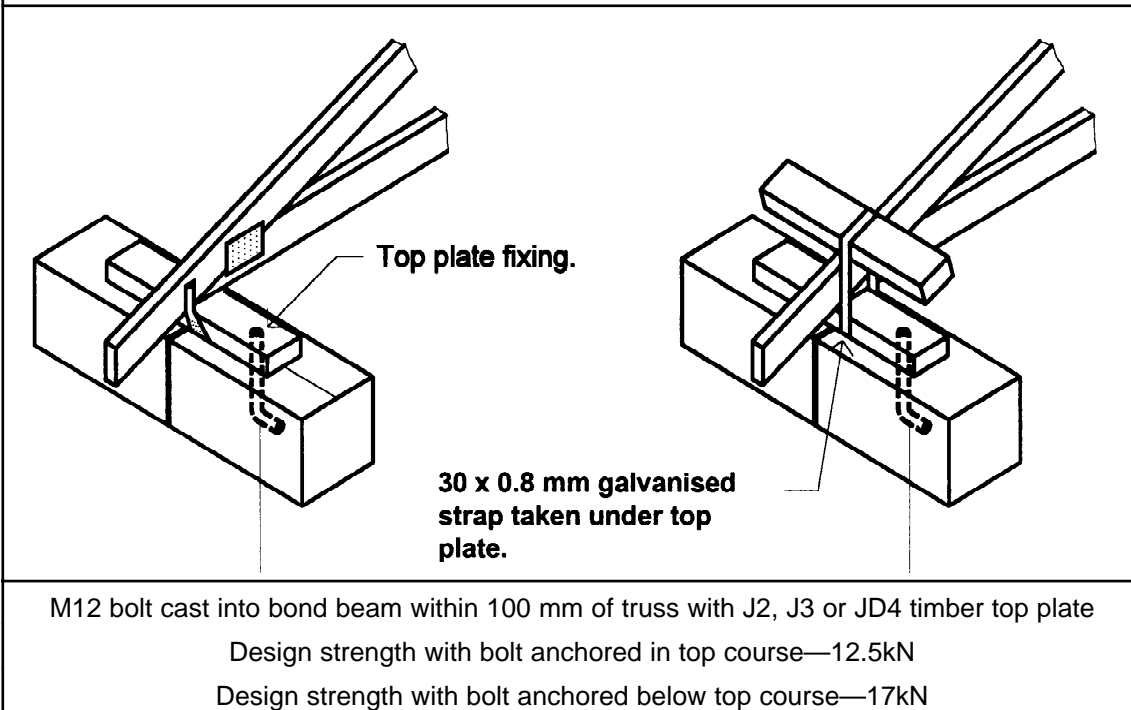

Figure 3.3.2.7(b)

TYPICAL TRUSS TIE DOWN METHODS—USING TOP PLATE



Explanatory information:

Joint groups (J2, J3 and JD4) are a classification of the strength of a timber species for the purpose of joint design. Typically, mixed Australian grown softwoods are joint group JD4 and mixed hardwoods are joint group J2 or J3.

- (h) Gable ends to buildings must be constructed in accordance with one of the following:
 - (i) Where a timber frame is used above the *bond beam* the gable end must be supported by a ceiling diaphragm in accordance with [Figure 3.3.2.8](#), Diagram a, by—
 - (A) anchoring the end truss to the wall; or
 - (B) bracing the end truss back to the internal trusses.
 - (ii) Where block work continues above the *bond beam*, fixed to the blockwork in accordance with [Figure 3.3.2.8](#), Diagram b.

Figure 3.3.2.8

TYPICAL GABLE END CONSTRUCTION DETAILS

Diagram a.

Timber frame above *bond beam*

MAXIMUM HORIZONTAL
SPACING OF FIXINGS

Design wind speed W33 - 3.6 m

Design wind speed W41 - 3.6 m

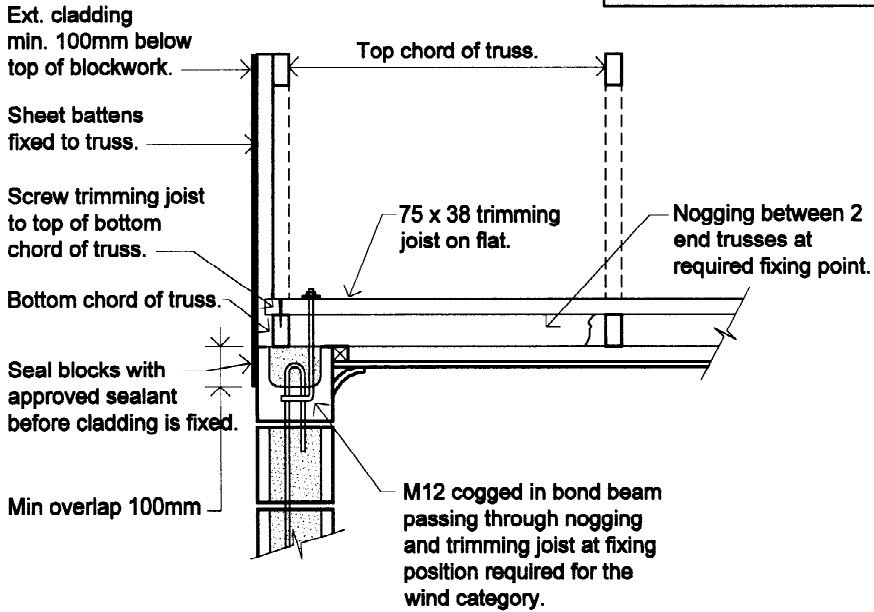

Diagram b.

Blockwork above *bond beam*

**MAXIMUM HORIZONTAL SPACING
OF FIXINGS**

Design wind speed W33 - 3.6 m

Design wind speed W41 - 2.4 m

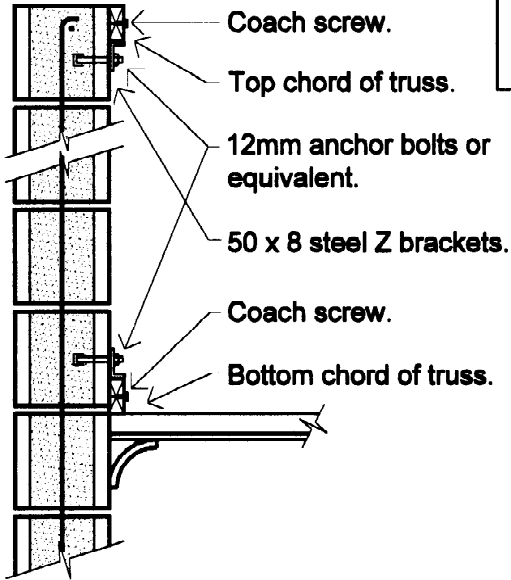

PART 3.3.3 MASONRY ACCESSORIES

Appropriate Performance Requirements

Where an alternative masonry accessory is proposed as an *Alternative Solution* to that described in Part 3.3.3, that proposal must comply with—

- (a) *Performance Requirement P2.1*; and
- (b) the relevant *Performance Requirements* determined in accordance with **1.0.10**.

A. Acceptable construction manual

3.3.3.0

Performance Requirement P2.1 is satisfied for masonry accessories if they are constructed and installed in accordance with AS 3700—Masonry Code.

B. Acceptable construction practice

3.3.3.1 Application

Compliance with this Part satisfies *Performance Requirement P2.1* for masonry accessories provided—

- (a) the building is located in an area with a *design wind speed* of not more than W41; and

Explanatory information:

1. Information on wind speeds for particular areas may be available from the *appropriate authority*.
2. Masonry walls in an area with a *design wind speed* of more than W41 must be designed in accordance with AS 3700.

- (b) for earthquake design, the building is defined as a design category H1 or H2 domestic structure in accordance with AS 1170.4; and

Explanatory information:

1. This covers all *sites* except those identified by the site investigation as having soft soil (having a soil profile with more than 5 m of soft clay, loose sand, silt or uncontrolled fill) as defined by AS 1170.4.
2. For earthquake design H3, see AS 3700.

- (c) The building is not constructed in an *alpine area*.

3.3.3.2 Wall ties

- (a) Masonry wall ties must be used to connect—
 - (i) masonry veneer wall cladding to a timber or metal *loadbearing* frame complying with **Part 3.4**; and
 - (ii) the two leaves of *cavity* masonry; and
 - (iii) two leaves of masonry forming a single wall with no *cavity*; and
 - (iv) intersecting masonry walls at a joint where course bonding is not employed.
- (b) Where articulation joints occur in masonry walls, ties must be built in both sides of the joint and spaced not more than 300 mm from the joint (see **Figure 3.3.3.1**).
- (c) Masonry wall ties must be installed in such a manner as to prevent moisture travelling along the tie to the inner leaf of masonry or frame.
- (d) Masonry veneer ties must be installed in accordance with Figure 3.3.3.1.
- (e) Wall ties must be classified in accordance with AS/NZS 2699.1 and installed as follows:
 - (i) Light duty ties must only be used in veneer clad buildings in areas where the *design wind speed* is not more than W33, and must be spaced in accordance with **Figure 3.3.3.1** as if for medium duty ties.
 - (ii) Medium duty ties must be—
 - (A) for veneer and *cavity* construction—spaced in accordance with **Figure 3.3.3.1**; and
 - (B) for solid or monolithic construction, in accordance with **(f)**.
- (f) Ties for solid or monolithic construction must be medium duty classification spaced not more than 400 mm in each direction and—
 - (i) the intersection of internal and external *cavity* or solid masonry walls must be bonded at the joint using medium duty ties at not more than 400 mm vertical spacing; and
 - (ii) in walls more than 200 mm in thickness, an additional tie is *required* within the spacing specified in **(i)** for every 200 mm of the thickness of the masonry units making the connection.
- (g) Masonry wall ties must be protected against corrosion in accordance with **Table 3.3.3.1**.

Figure 3.3.3.1	
TYPICAL BRICK TIES SPACINGS IN CAVITY AND VENEER CONSTRUCTION	
Note:	
1.	Solid masonry ties must be of a size appropriate to the <i>cavity</i> width and built not less than 50 mm into each leaf.
2.	Wall tie spacings indicated on the diagram are indicative and may be reduced according to nature of the wall.
3.	Location of wall ties immediately adjacent to ties connecting an intersecting wall may be increased to not more than 600 mm away from the intersecting wall ties.
Diagram a.—Spacing for medium duty wall ties—cavity and veneer construction	
Legend:	For the purposes of this diagram:

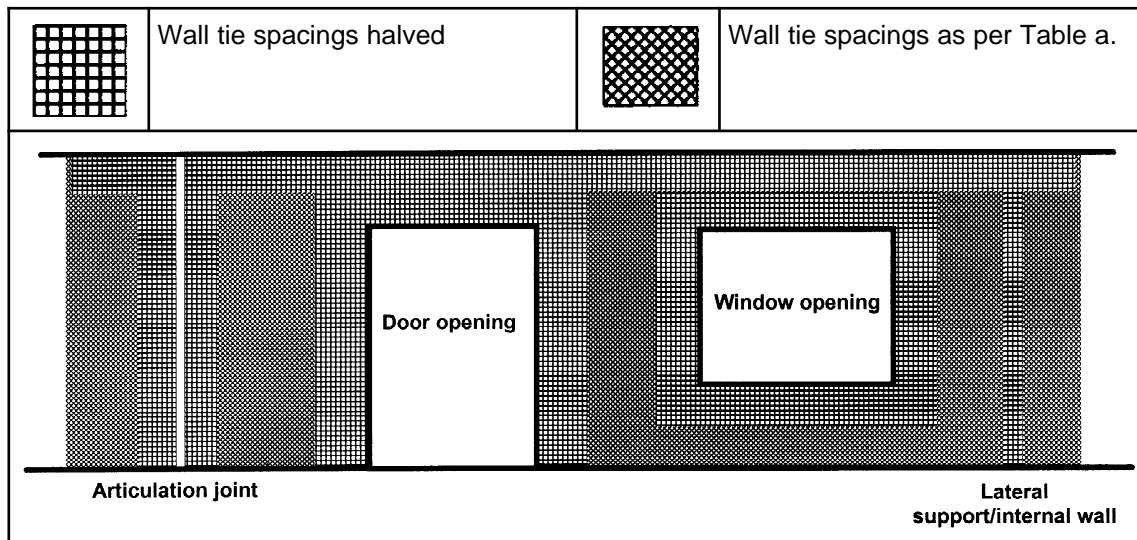

Table a.—Spacing for medium duty wall ties—cavity and veneer construction

DESIGN WIND SPEED (non-cyclonic)	CAVITY MASONRY	MASONRY VENEER CONSTRUCTION	
		450 STUD WALLS	600 STUD WALLS
W28–W41	600 x 600	600 x 450	600 x 600
Note:			
1.	Inner leaf masonry thickness 70 to 150 mm for cavity walls.		
2.	Around openings and at control joints, the vertical tie spacings are halved (ie the number of ties must be doubled).		
3.	In veneer construction, masonry must be tied to stud wall framing at all regular stud positions, including gable ends.		

Table 3.3.3.1 CORROSION PROTECTION FOR WALL TIES

EXPOSURE CONDITION	TIE SPECIFICATION (minimum corrosion protection)
Areas— <ul style="list-style-type: none"> • less than 1 km from breaking surf; or • less than 100 m from salt water not subject to breaking surf; or • within heavy industrial areas. 	<ul style="list-style-type: none"> • Grade 316 or 316L stainless steel. • Engineered polymer.
Areas— <ul style="list-style-type: none"> • 1 km or more but less than 10 km from breaking surf; or 	<ul style="list-style-type: none"> • Sheet steel ties galvanised after manufacture—470g/m² on each side. • Galvanised wire ties—470g/m² coating mass.

EXPOSURE CONDITION	TIE SPECIFICATION (minimum corrosion protection)
<ul style="list-style-type: none"> • 100 m or more but less than 1 km from salt water not subject to breaking surf. 	
<p>All other areas.</p>	<ul style="list-style-type: none"> • Ties manufactured from galvanised sheet steel—Z600. • Sheet steel ties galvanised after manufacture—300g/m² on each side.

Explanatory information:

Wall ties that are suitable for use in a more severe exposure condition are also suitable for use in the less severe exposure conditions, ie stainless steel and engineered polymer ties are suitable for use in all conditions and 470g/m² galvanised ties can be used in all exposure conditions except the most severe.

3.3.3.3 Fixing straps and tie down systems

- (a) Timber door and *window* frames abutting masonry must be—
 - (i) fixed with 300 mm long 32×0.8 mm kinked galvanised steel straps; and
 - (ii) fixed to back of frames; and
 - (iii) set into courses not less than 150 mm at not more than 400 mm intervals.
- (b) For areas with a *design wind speed* of W28 or W33 and a roof system span of not more than 10 m, sheet metal and tiled roofs must be tied down using one of the following methods:
 - (i) 32×0.8 mm galvanised steel straps at not more than 1.2 m centres and corresponding with truss or rafter positions, looped around 10 mm diameter galvanised mild steel rods—
 - (A) built in across the *cavity* at a course not less than 900 mm below the top of the wall; and
 - (B) embedded not less than 50 mm into each leaf.
 - (ii) 25×1 mm galvanised steel straps at not more than 1.2 m centres and corresponding with truss or rafter positions, built into the masonry inner leaf not less than 50 mm and 900 mm below the top of the wall (see [Figure 3.3.3.3](#)).

Figure 3.3.3.3

SUITABLE TIE DOWN STRAP DETAILS

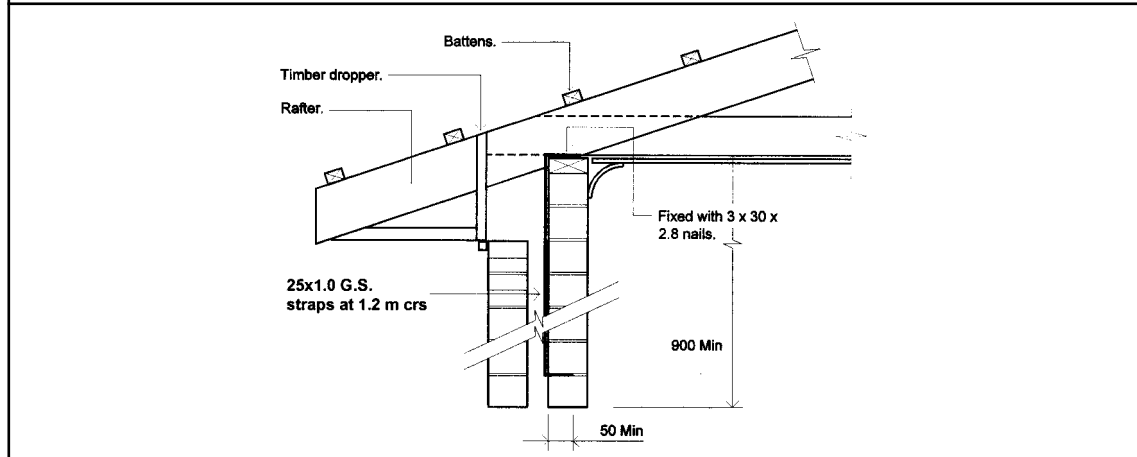

3.3.3.4 Lintels

- (a) Lintels in masonry may be—
- steel lintels complying with this Part; or
 - steel lintels complying with AS 4100, AS/NZS 4600; or
 - reinforced concrete beams designed in accordance with AS 3600.

Explanatory information:

Lintels that support structures other than masonry walls are covered in [Section 3.4.4](#)—Structural steel members.

- (b) Steel lintels must comply with [Figure 3.3.3.5](#) and—
- the long leg of angles must be vertical (see [Figure 3.3.3.4](#)); and
 - each angle or flat can carry a maximum 110 mm wall thickness; and
 - the minimum bearing length at each end of the lintel must be—
 - for clear spans less than 1 m—100 mm; and
 - for clear spans more than 1 m—150 mm (see [Figure 3.3.3.4](#)); and
 - there must be not less than three courses of brickwork over openings; and
 - all loads must be uniformly distributed (point loads are not allowed).
- (c) Corrosion protection of lintels must be in accordance with [Table 3.4.4.2](#).

Figure 3.3.3.4
LINTEL INSTALLATION

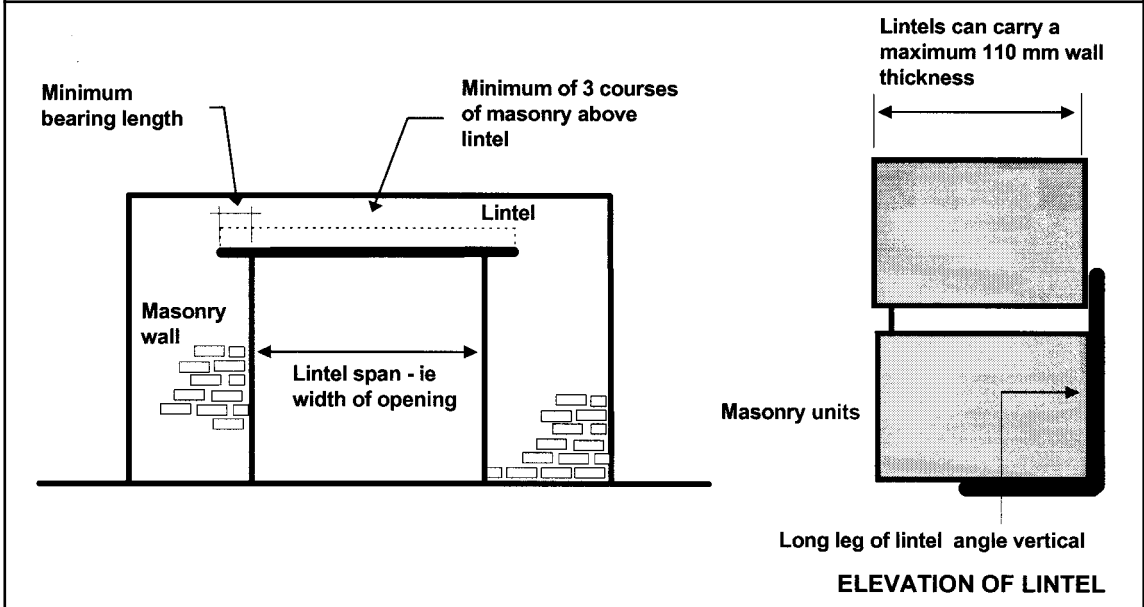

Figure 3.3.3.5
LINTELS SUPPORTING ROOFS AND MASONRY WALLS

Diagram a.—Lintel types as described in Table a.

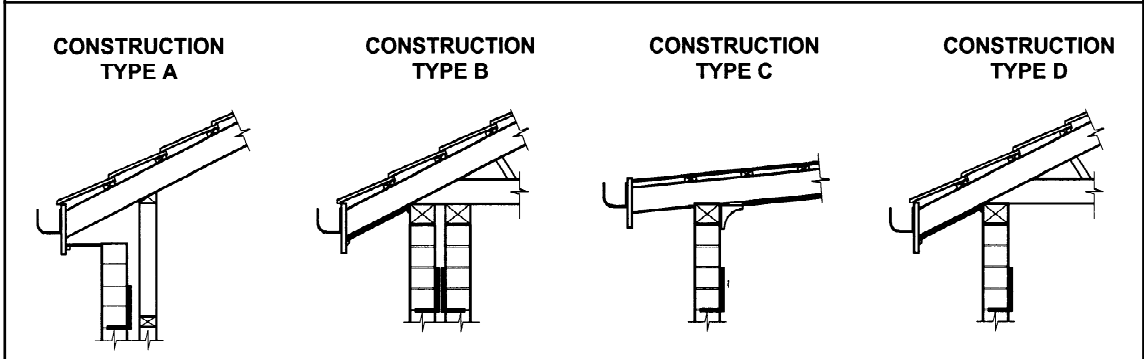

Table a.—Lintels spans

Design wind speed not more than W41—Maximum roof span 10 m

Steel Section	Mass(kg/m)	Construction Type See Diagram a.			
		A	B	C	D
Angles		MAXIMUM CLEAR SPAN OF LINTEL (mm)			
90x90x6EA	8.22	3010	2050	2050	1570
90x90x8EA	10.6	3010	2170	2170	1810
100x100x6EA	9.16	3130	2290	2290	1810

Figure 3.3.3.5

LINTELS SUPPORTING ROOFS AND MASONRY WALLS

100x100x8EA	11.8	3370	2410	2410	1930
150x90x8UA	14.3	4210	3370	3370	2770
150x100x10UA	18	4330	3490	3610	3010
Flats					
75x8	4.71	490	250	–	–
75x10	5.89	610	250	250	250

PART 3.3.4 WEATHERPROOFING OF MASONRY

Appropriate Performance Requirements

Where an alternative waterproofing system is proposed as an *Alternative Solution* to that described in Part 3.3.4, that proposal must comply with— **P2.2.2** in Section 2.

- (a) *Performance Requirement* **P2.2.2**; and
- (b) the relevant *Performance Requirements* determined in accordance with **1.0.10**.

3.3.4 Application of this Part

- (a) This Part applies to every external wall (including the junction between the wall and any window or door) of a Class 1 building.
- (b) This Part does not apply to any Class 10 building except where its construction contributes to the weatherproofing of the Class 1 building.

A. Acceptable construction manual

3.3.4.0

Performance Requirement **P2.2.2** is satisfied for weatherproofing of masonry if it is carried out in accordance with the appropriate provisions of AS 3700.

B. Acceptable construction practice

3.3.4.1 Application

Compliance with this Part satisfies *Performance Requirement* **P2.2.2** for weatherproofing of masonry, provided the masonry wall is constructed in accordance with **Part 3.3.1** or **Part 3.3.2**.

3.3.4.2 Width of cavity

In brick veneer and *cavity* masonry construction, a *cavity* must be provided between the inner and outer walls as follows:

- (a) Brick veneer—not less than 25 mm width.
- (b) *Cavity* masonry—not less than 35 mm nor more than 65 mm width.
- (c) The minimum *cavity* width specified in (a) and (b) is to be maintained between the outer masonry leaf and any services, insulation, sheet bracing or other element located in the *cavity*.

3.3.4.3 Cavity ventilation and drainage

Open perpendicular joints (weepholes) must be created in the course immediately above any *DPC* or *flashing*, at centres not exceeding 1.2 m, except in the following situations:

- (a) Weepholes are not *required* for head or sill openings less than 1 m wide.
- (b) Weepholes are not *required* where—
 - (i) the external masonry is weatherproofed in accordance with [3.3.4.12\(a\)](#); and
 - (ii) the perimeter joint of all windows are sealed; and
 - (iii) a *damp-proof course* is installed in accordance with [3.3.4.5](#).

Figure 3.3.4.1

LOCATION OF DPCs AND FLASHINGS IN SUB-FLOOR STRUCTURES

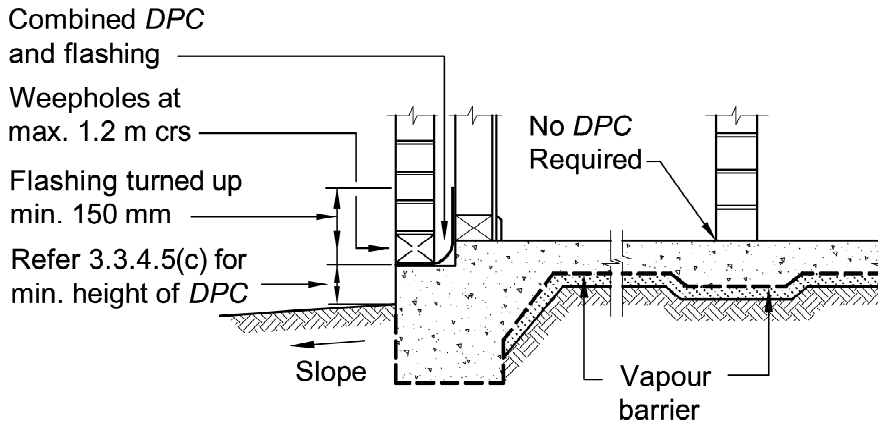

(a) Masonry veneer

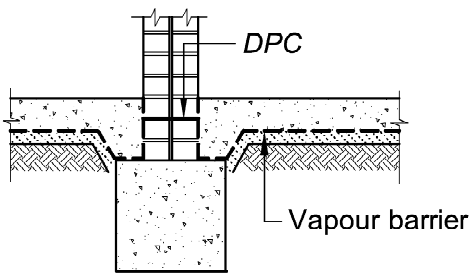

(b) Internal wall

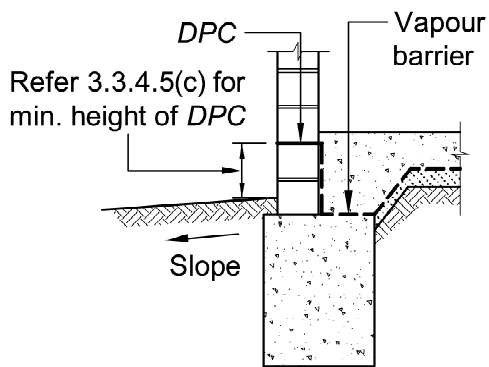

(c) Single leaf

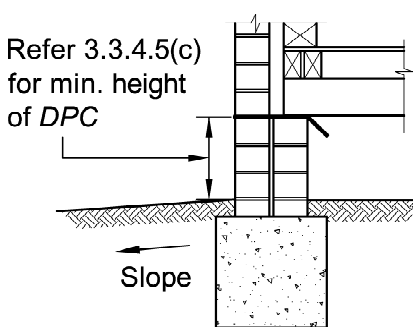

(d) Suspended floor

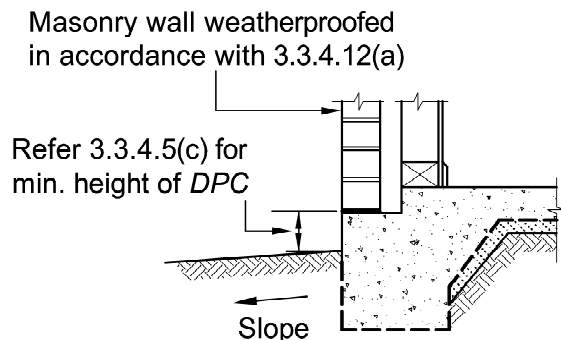

(e) Weatherproofed masonry veneer

3.3.4.4 Damp-proof courses—materials

Damp-proof courses must consist of—

- (a) a material that complies with AS/NZS 2904; or
- (b) embossed black polyethylene film of high impact resistance and low slip, with a nominal thickness of 0.5 mm prior to embossing, and meeting the requirements of clause 7.6 of AS/NZS 2904; or
- (c) polyethylene coated metal, that has an aluminium core of not less than 0.1 mm thick, is coated both sides with bitumen adhesive enclosed in polyethylene film of not less than 0.1 mm thick on each face, and has a nominal total thickness of not less than 0.5 mm prior to embossing; or
- (d) bitumen impregnated materials of not less than 2.5 mm thickness, that meet the requirements of clause 7.5 of AS/NZS 2904, when used in walls which are not higher than 7.8 m above the level of the *DPC*; or
- (e) termite shields (with no penetrations) continuous through the wall or pier.

STATE AND TERRITORY VARIATIONS

In South Australia delete 3.3.4.4 and insert SA 3.3.4.4 as follows:

SA 3.3.4.4 Damp-proof courses—materials

Damp-proof courses and *flashings* used as *DPC*'s must consist of—

- (a) embossed black polyethylene film meeting the requirements of clause 7.6 of AS/NZS 2904; or
- (b) polyethylene coated aluminium meeting the requirements of clause 7.4 of AS/NZS 2904; or
- (c) bitumen impregnated materials of not less than 2.5 mm thickness, meeting the requirements of clause 7.5 of AS/NZS 2904, when used in walls not higher than 7.8 m above the level of the *damp-proof course*.

3.3.4.5 Damp-proof courses—installation

- (a) *DPC*s must be—
 - (i) located in accordance with [Figure 3.3.4.1](#) to form a continuous damp-proofing barrier around buildings, and in walls and piers below suspended floors; and
 - (ii) of sufficient width to extend through the entire width of the masonry leaves.
- (b) A *flashing* that extends through the entire width of the masonry leaves may also be used as a *DPC* (see [Figure 3.3.4.1](#)).
- (c) The height of a *DPC*, or *flashing* serving as a *DPC*, (see [Figure 3.3.4.1](#)), must be not less than—
 - (i) 150 mm above the adjacent ground level; or
 - (ii) 75 mm above the finished surface level of adjacent paved, concreted or landscaped areas that slope away from the wall (see [Figure 3.3.4.1](#)); or

- (iii) 50 mm above finished paved, concreted or landscaped areas complying with **3.1.2.3(b)(iii)** and protected from the direct effects of the weather by a carport, verandah or the like.

Explanatory information:

150 mm clearance between the *DPC* and adjacent ground level reduces the risk of the effectiveness of the *DPC* being affected by changes in the surface level. Where changes in surface level are less likely to occur, such as where the adjacent surface is finished with paving, concreting or landscaping, the height of the *DPC* above that surface may be reduced to 75 mm. When also protected from the weather by a carport, verandah or the like the height of the *DPC* may be reduced to 50 mm.

- (d) Masonry units and mortar below the lowest *DPC* must be of the appropriate classification for the exposure condition (see **Table 3.3.1.1** and **Table 3.3.1.2**).
- (e) *DPCs* may be stepped where a change in floor level occurs.
- (f) *DPCs* must be installed under the coping to parapets where the parapet is more than 300 mm above the adjoining roof cladding (see **Figure 3.3.4.2**).
- (g) In chimney stacks—
 - (i) the *DPC* must be installed between 150 mm and 300 mm above the highest point where the chimney meets the roof; or
 - (ii) two *DPCs* may be used to avoid a high *flashing* upstand (see **Figure 3.3.4.3**).
- (h) Lap joints in a *DPC* must be not less than 150 mm.

Explanatory information:

A *DPC* is used to prevent the penetration of water and moisture into a building. As a result, careful consideration must be given to the location of a *DPC* and its intended use. In addition to the provision of this clause, termite risk management in accordance with **Clause 3.1.3** may also need to be considered when determining the appropriate location of the *DPC*.

STATE AND TERRITORY VARIATIONS

In South Australia delete 3.3.4.5(b) and (c) and insert SA 3.3.4.5(b) and (c) as follows:

- (b) A *flashing* that extends through the entire width of the masonry leaves and complies with SA 3.3.4.4 may also be used as a *DPC*.
- (c)
 - (i) Where there is no perimeter termite barrier installed, the height of a *DPC*, or a *flashing* serving as a *DPC* (see **Figure 3.3.4.1**) must be not less than 75 mm above the finished paved areas.
 - (ii) Where there is a perimeter termite barrier installed and the site classification is A, S, M-D, or H-D, the height of a *DPC*, or a *flashing* serving as a *DPC* (see **Figure 3.3.4.1**), must be not less than—
 - (A) 15 mm above the finished paving level; or
 - (B) level with the finished paved area that is graded in accordance with SA 3.1.2.3 and which is protected from the direct effects of the weather by a carport, verandah or the like.

- (iii) Where there is a perimeter termite barrier installed and the site classification is E or P, the height of a DPC, or a flashing serving as a DPC (see [Figure 3.3.4.1](#)), must be not less than 75 mm above the finished paving level.

Figure 3.3.4.2

INSTALLATION OF DPCs AND FLASHINGS FOR PARAPET WALLS

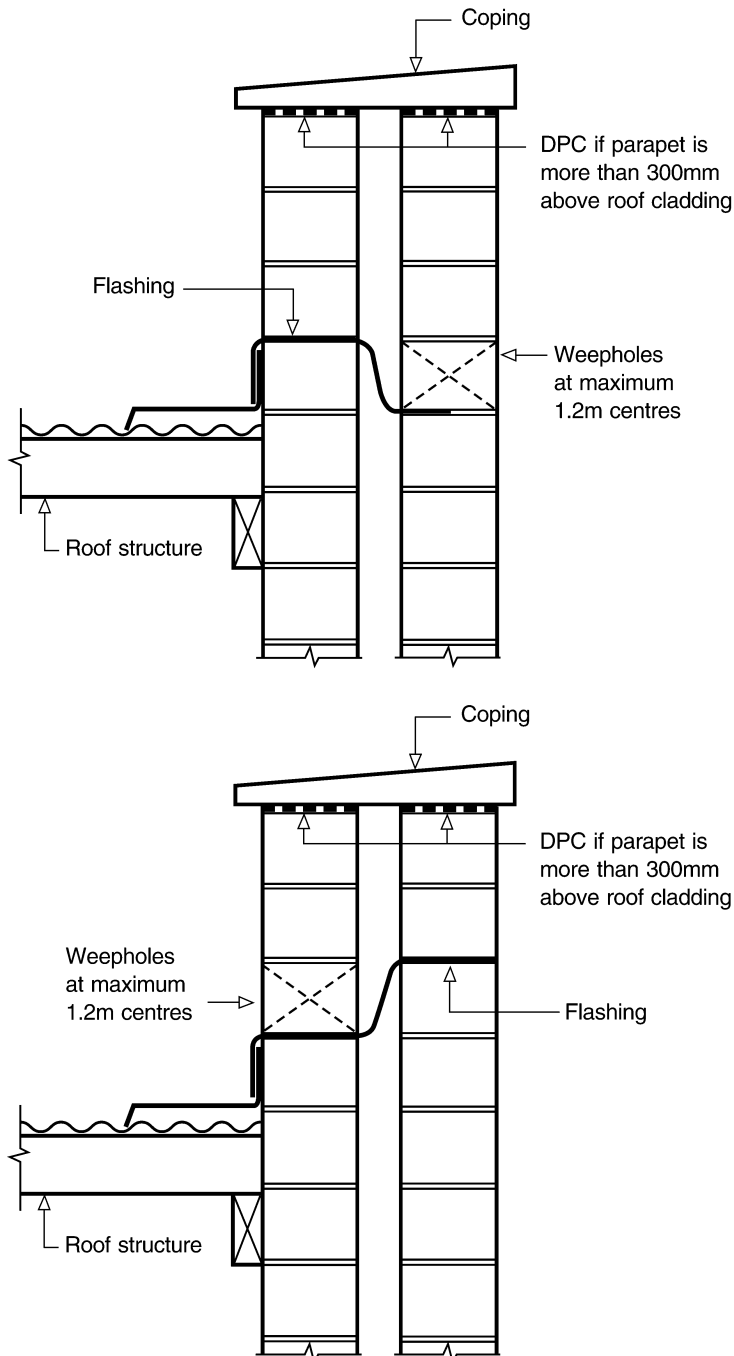
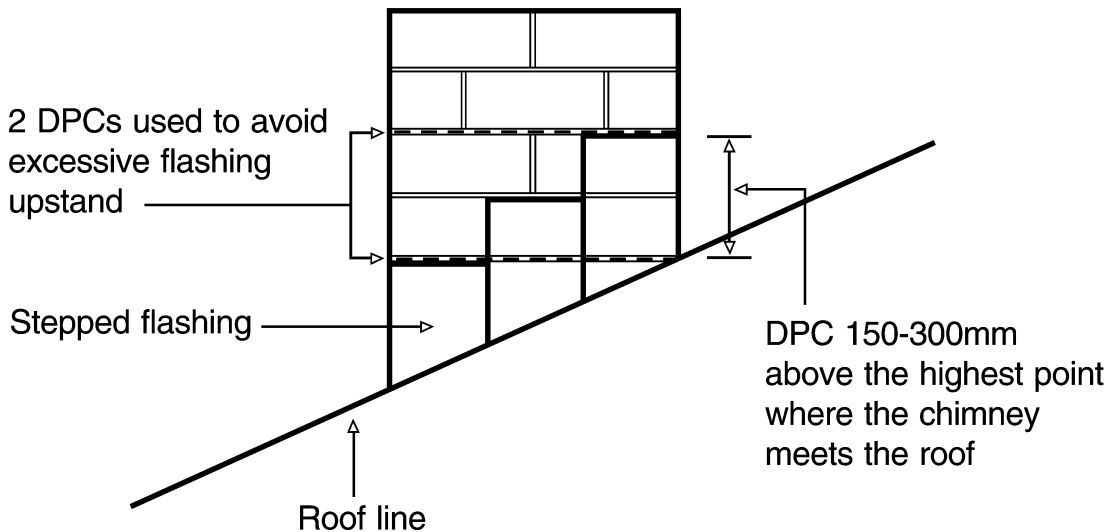
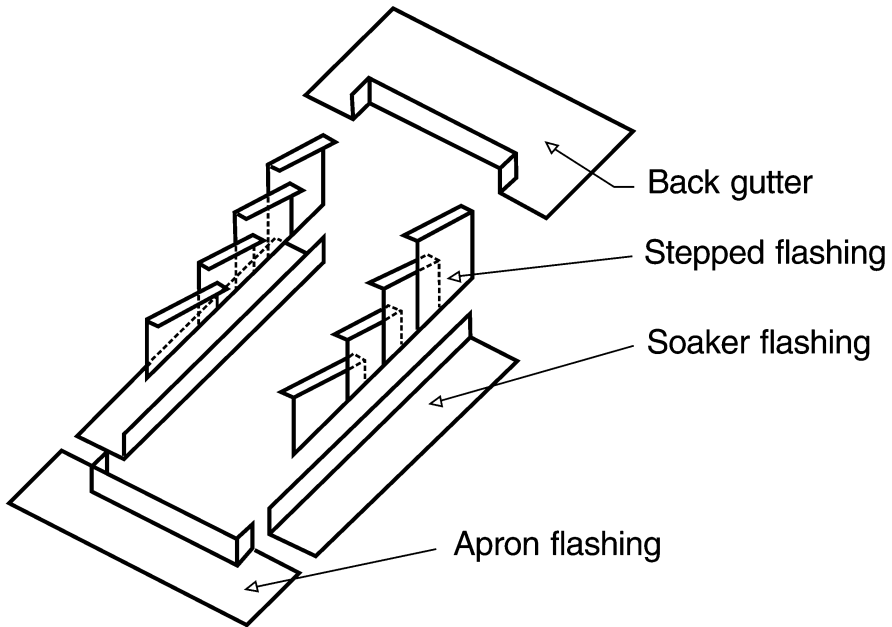

Figure 3.3.4.3

INSTALLATION OF DPCs AND FLASHINGS FOR CHIMNEYS



3.3.4.6 Flashings

Flashings materials must comply with AS/NZS 2904 or [Table 3.3.4.1](#) and—

- (a) be built in as the work proceeds; and
- (b) where electrolytic action could otherwise occur, different materials must be isolated in accordance with [Table 3.5.1.2](#); and
- (c) lead flashings must not be used on any roof that is part of a potable water catchment area.

STATE AND TERRITORY VARIATIONS

In South Australia delete 3.3.4.6 and insert SA 3.3.4.6 as follows:

SA 3.3.4.6 Flashings

- (a) *Flashing* materials (except where used as a *DPC*) must comply with AS/NZS 2904 or [Table 3.3.4.1](#) and—
 - (i) be built in as the work proceeds; and
 - (ii) where electrolytic action could otherwise occur, different materials must be isolated in accordance with [Table 3.5.1.2](#).
- (b) *Flashings* used as *DPCs* must comply with SA 3.3.4.4.

Table 3.3.4.1 SUITABLE FLASHING MATERIALS FOR CONCEALED AND EXPOSED LOCATIONS

LOCATION	SUITABLE FLASHING MATERIAL
CONCEALED (e.g. <i>cavity flashing</i>)	<ul style="list-style-type: none"> • Uncoated annealed lead having a mass of not less than 10 kg/m². • Uncoated copper having a mass of not less than 2.8 kg/m² and having a thickness of 0.3 mm to 0.5 mm. • Bitumen coated metal (normally aluminium) with a total coated thickness of 0.6 to 1.00 mm. • Zinc coated steel with a thickness of not less than 0.6 mm • Embossed/Quilted polyethylene sheet with an average thickness of not less than 0.5 mm.

LOCATION	SUITABLE FLASHING MATERIAL
EXPOSED (e.g. roof to masonry wall flashings)	<ul style="list-style-type: none"> • Uncoated annealed lead having a mass of not less than 20 kg/m² in lengths not exceeding 1.5 m. • Uncoated copper having a mass of not less than 2.8 kg/m² and having a thickness of 0.3 mm to 0.5 mm. • Bitumen coated metal (normally aluminium) with a total coated thickness of 0.6 to 1.00 mm. • Zinc coated steel with a thickness of not less than 0.6 mm.

Figure 3.3.4.4

PROTECTION OF OPENINGS IN EXTERNAL WALLS

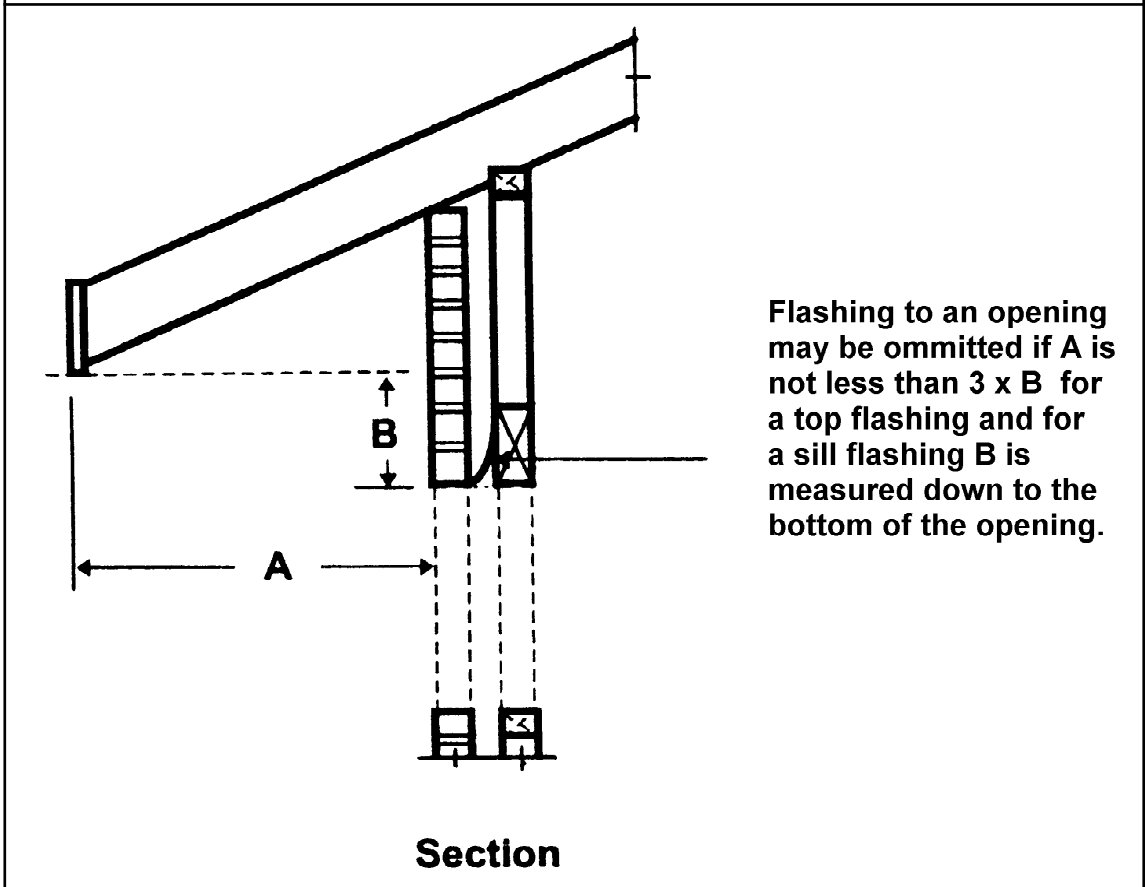

Figure 3.3.4.5

INSTALLATION OF SILL AND HEAD FLASHINGS

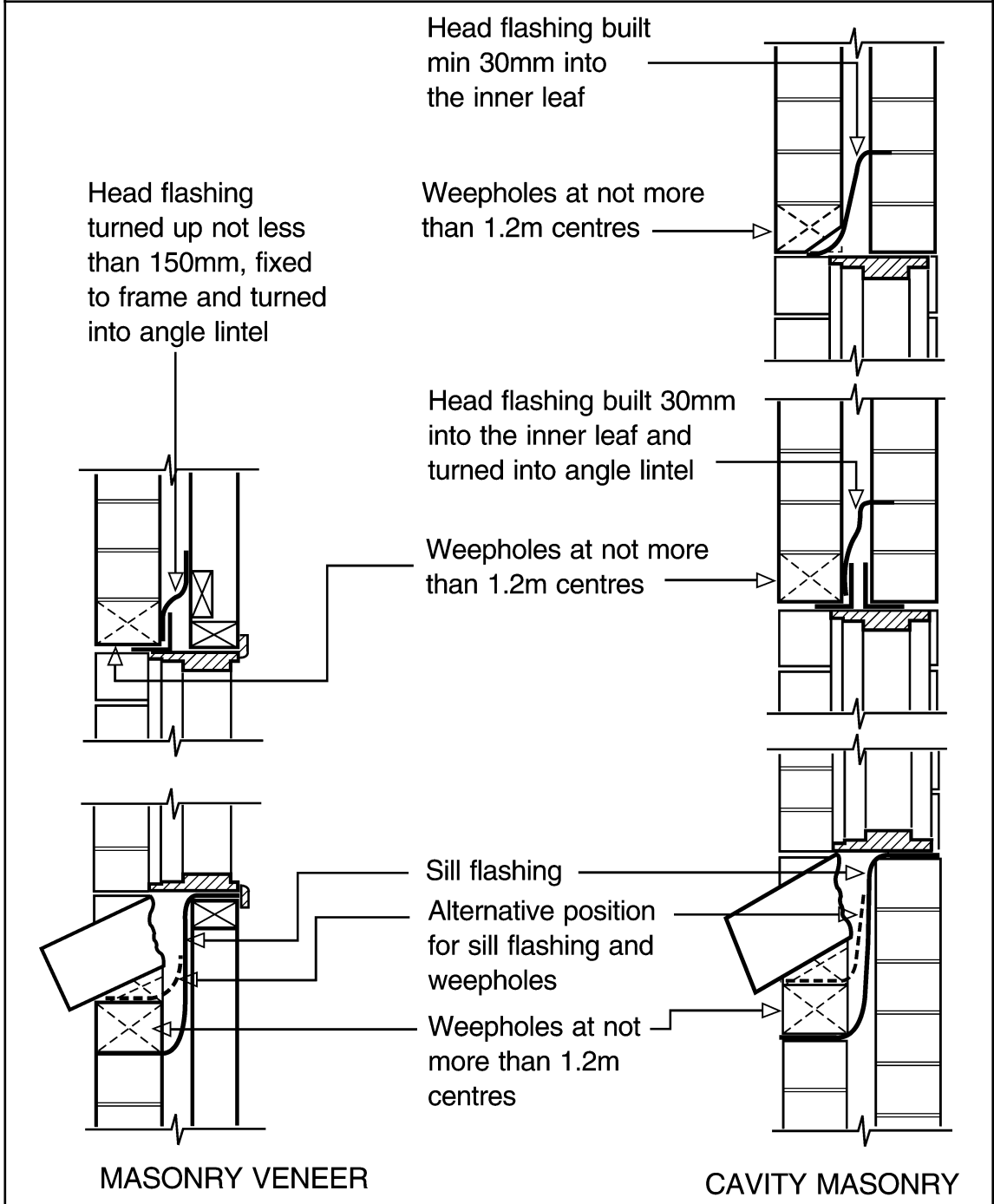

Figure 3.3.4.6

INSTALLATION OF FLASHINGS AT ROOF/WALL JUNCTIONS

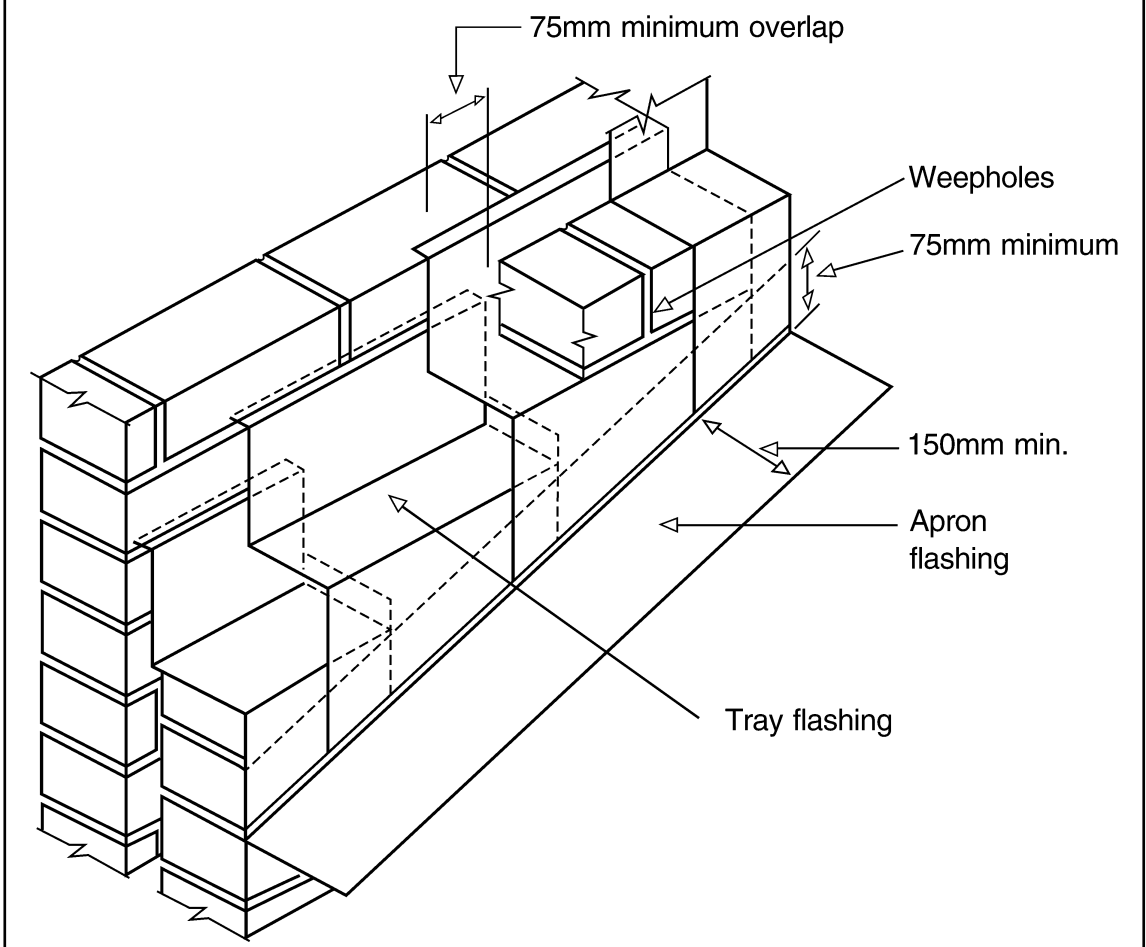
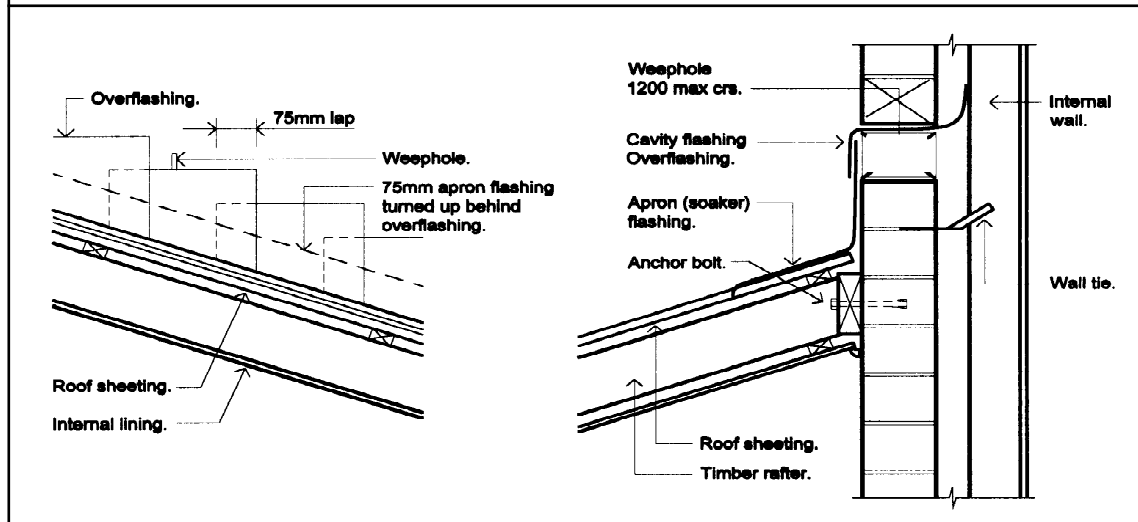

Figure 3.3.4.7

STEPPED CAVITY FLASHINGS



3.3.4.7 Location of flashings

A *flashing* must be provided—

- (a) where the *cavity* of a *cavity* masonry or masonry veneer wall is interrupted by a structural element (other than a wall tie), opening or the like; and
- (b) within the *cavity* where a roof abuts a *cavity* wall and an external masonry leaf or veneer becomes a wholly or partly internal wall; and
- (c) from an external masonry leaf or veneer onto an abutting roof; and
- (d) at the base of a *cavity* where—
 - (i) there is no other means of dispersing water from the *cavity*; and
 - (ii) the external masonry has not been waterproofed in accordance with [3.3.4.12\(a\)](#); and
- (e) from a masonry chimney onto the abutting roof.

3.3.4.8 Flashings at the base of cavity walls

A *flashing* at the base of a *cavity* masonry or masonry veneer wall—

- (a) in masonry veneer construction, must extend across the *cavity* and be turned up not less than 150 mm and fixed to the frame; and
- (b) in *cavity* masonry construction, must extend across the *cavity* and be turned up not less than 150 mm and built 30 mm into the inner masonry leaf; and
- (c) must have a continuous fall towards the outer leaf or veneer.

3.3.4.9 Sill and head flashing

(a) A *flashing* above (*head flashing*) and below (*sill flashing*) an opening in a *cavity* wall—

- (i) must extend not less than 100 mm past each side of the opening; and
 - (ii) must extend across the cavity and have a continuous fall towards the outer leaf or veneer.
- (b) A head *flashing*—
- (i) in masonry veneer construction, must be turned up not less than 150 mm and fixed to the frame; and
 - (ii) in *cavity* masonry construction, must be turned up not less than 150 mm and built 30 mm into the inner leaf (see [Figure 3.3.4.5](#)).
- (c) A sill or head *flashing* may be omitted where the opening is protected by eaves or the like with a width of not less than three times the distance between the location of the *flashing* and the overhang (see [Figure 3.3.4.4](#)).

3.3.4.10 Flashings at a roof abutting a wall

- (a) For a *cavity* wall, an end or raked apron *flashing* must be installed where the external masonry leaf or veneer abuts a roof and must—
- (i) follow the roof line, allowing not less than 75 mm upturn to the masonry and 150 mm in width for dressing or scribing onto the roof covering; and
 - (ii) have a horizontal overflashing, stepped overflashing or raked overflashing built into the masonry leaf or veneer, except that one continuous *flashing* may be used as both an apron *flashing* or an overflashing; and
 - (iii) for parapets, be installed in accordance with [Figure 3.3.4.2](#).
- (b) Where a roof abuts a *cavity* wall, and an external masonry leaf or veneer becomes wholly or partly an internal wall, a tray *flashing* must be installed in the cavity and—
- (i) the tray *flashing* may be stepped to follow the rake of the roof provided that each tray *flashing* overlaps the one below by not less than 75 mm; and
 - (ii) the tray *flashing* must cover the vertical leg of the apron *flashing* required by (a) (see [Figure 3.3.4.6](#)).
- (c) For a single leaf masonry wall, an apron *flashing* onto an abutting roof must be not less than 150 mm in width for dressing or scribing onto the roof covering and must be—
- (i) stepped to follow the rake of the roof; or
 - (ii) set not less than 30 mm into a groove cut into the masonry parallel and between 100–150 mm above the line of the roof covering.

3.3.4.11 Chimney flashings

- (a) *Flashings* to chimneys must consist of an apron, stepped overflashings, soaker *flashings* and a back gutter (see [Figure 3.3.4.3](#)).
- (b) The apron *flashing* must be turned up the masonry not less than 75 mm and be dressed over the roof covering not less than 150 mm and installed under the soaker *flashing* not less than 75 mm.
- (c) The soaker *flashings* must be turned up the masonry not less than 75 mm and be lapped over the roof covering not less than 150 mm and installed under the back gutter not less than 75 mm.

- (d) The back gutter must be turned up the masonry not less than 75 mm, be lapped under the roof covering not less than 150 mm and extend past the full width of the soaker *flashings*.
- (e) The stepped *flashings* must be built not less than 30 mm into the masonry and must completely cover the vertical leg of the apron *flashings*, soaker *flashings* and back gutter.

3.3.4.12 Weatherproofing for single skin masonry walls

- (a) A waterproof coating material must be applied to all external single skin masonry walls in accordance with the following:
 - (i) The coating must extend from the upper most exposed part of the wall—
 - (A) to a level adjacent the internal finished floor level, if the external blockwork overhangs the edge of the slab 10 mm; or
 - (B) 50 mm below the internal floor level if no edge overhang is provided to the blockwork (see [Figure 3.3.4.9](#)).
 - (ii) Acceptable external waterproof finishes are—
 - (A) three coats of 100% acrylic based exterior quality gloss paint; or
 - (B) one complete coat of cement based paint and two coats of 100% acrylic based exterior quality gloss paint; or
 - (C) clear water repellent, provided the wall is protected by a roof overhang.
- (b) *Windows* must be installed in accordance with [Figure 3.3.4.8](#).
- (c) A damp-proof course and vapour barrier or damp-proofing membrane must be installed in accordance with [Figure 3.3.4.9](#).

Limitation:

[3.3.4.12](#) does not apply to a Class 10 building where in the particular case there is no necessity for compliance.

Figure 3.3.4.8

TYPICAL WINDOW INSTALLATION DETAILS FOR SINGLE SKIN MASONRY

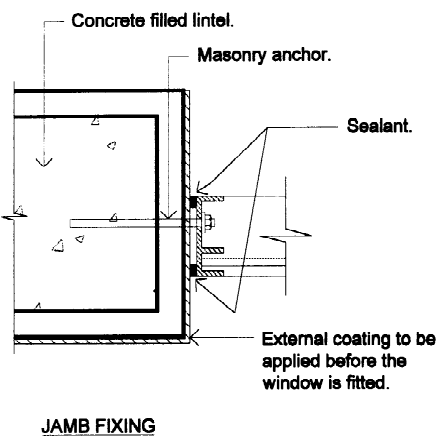
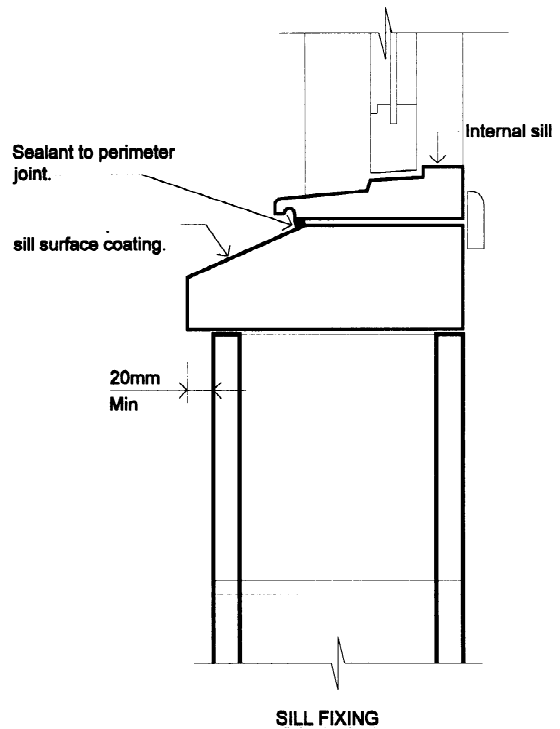
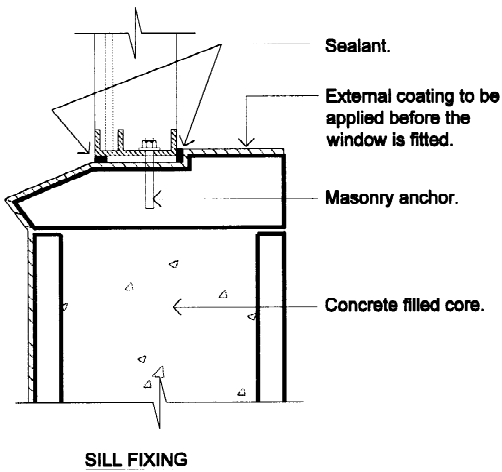
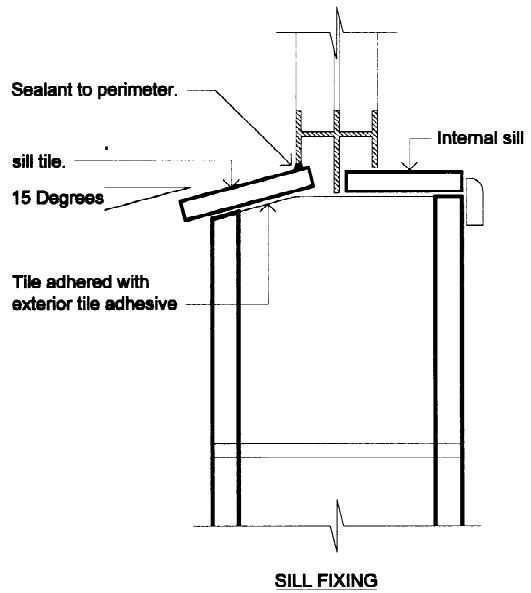
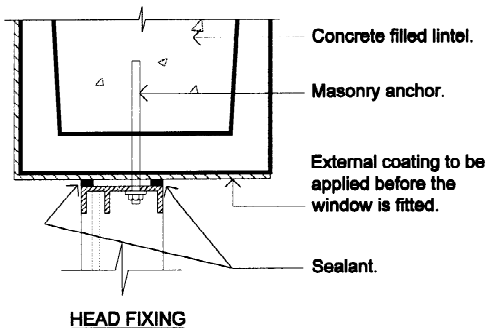

**Figure 3.3.4.9
TYPICAL DPC AND WEATHERPROOFING DETAILS FOR SINGLE SKIN MASONRY**

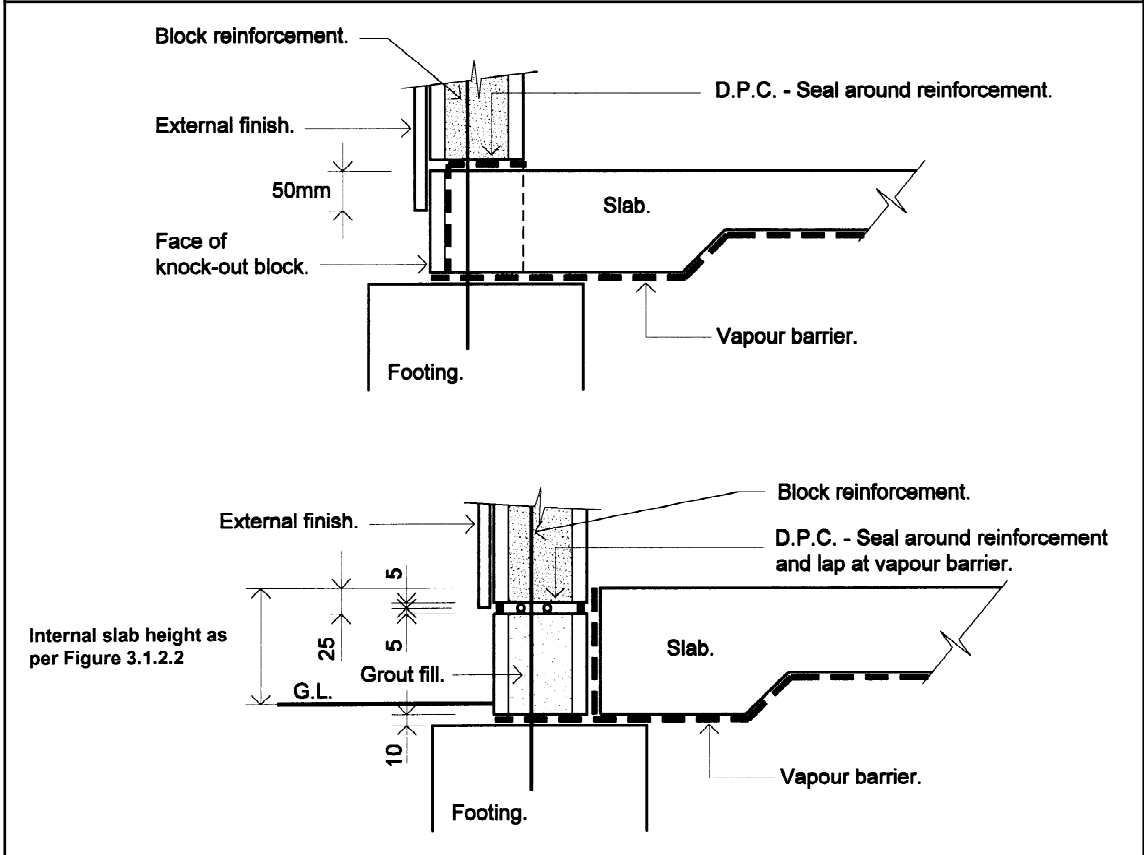

PART 3.3.5 EARTH WALL CONSTRUCTION

Appropriate Performance Requirements

Where an alternative earthwall building system is proposed as an *Alternative Solution* to that described in Part 3.3.5, that proposal must comply with—

- (a) *Performance Requirement* **P2.1**; and
- (b) *Performance Requirement* **P2.2.2**; and
- (c) the relevant *Performance Requirements* determined in accordance with **1.0.10**.

Definitions

3.3.5

For the purpose of this Part:

Adobe construction means a type of construction using blocks of sun dried mud.

Bulletin 5 means CSIRO-NBTC Bulletin 5 Earthwall construction 4th Edition 1987.

Earthwall construction means *adobe construction, mechanically pressed-soil block construction or rammed-earth construction*.

Mechanically pressed-soil block construction means construction using blocks produced by pressed block making machines.

Rammed-earth construction means construction in which damp earth is tamped in situ between temporary movable formwork.

A. Acceptable construction manual

3.3.5.0

Performance Requirements **P2.1** and **P2.2.2** are satisfied for *earthwall construction* if it is designed and constructed in accordance with *Bulletin 5*.

Explanatory information:

Design requirements for other materials that may be used in combination with masonry ie heavy steel support beams etc are described in **Part 3.11**—Structural design.

B. Acceptable construction practice

3.3.5.1 Application

Compliance with this Part satisfies *Performance Requirements* [P2.1](#) and [P2.2.2](#) for *earthwall construction*, provided—

- (a) the earthwall is constructed on footings that comply with [Part 3.2](#); and
- (b) the *design wind speed* of the area is not more than W41; and

Explanatory information:

Information on design wind speeds for particular areas may be available from the *appropriate authority*.

- (c) the *earthwall construction* does not exceed two storeys in height and walls must be laterally restrained at intermediate floor levels; and
- (d) the building is not situated on a *site* that is subject to flooding; and
- (e) for earthquake design, the building is defined as a design category H1 or H2 domestic structure in accordance with AS 1170.4.

Explanatory information:

1. This covers all *sites* except those identified by the *site* investigation as having soft soil (having a soil profile with more than 5 m of soft clay, loose sand, silt or uncontrolled fill) as defined by AS 1170.4.
2. For earthquake design H3, see AS 3700 or [Part 3.10.2](#).

3.3.5.2 General construction

A building of *earthwall construction* must be constructed in accordance with the recommendations contained in *Bulletin 5* except where varied by this Part.

3.3.5.3 Minimum thickness of walls

In a building of *earthwall construction*, the thickness of a wall must be—

- (a) in the case of *adobe construction* or *rammed-earth construction*—
 - (i) for an *external wall*, not less than 250 mm; and
 - (ii) for an internal wall, not less than 200 mm; and
- (b) in the case of *mechanically pressed-soil block construction*—
 - (i) for an *external wall*, not less than 250 mm; and
 - (ii) for an internal wall, not less than 150 mm.

3.3.5.4 Weatherproofing

Every building of *earthwall construction*—

- (a) must be provided with a suitable means of protection to prevent water from the roof running down the face of every wall; and

- (b) must, except in the case illustrated in Figure 1.3 of *Bulletin 5*, have the ground adjacent to the walls graded and paved in accordance with 1.2, 1.2.2 and 1.2.3 to prevent any *surface water* from reaching the walls.

Explanatory information:

Prior to and during construction, the following tests may be required by the *appropriate authority*—

- (a) In the case of—
- (i) *rammed-earth construction*—a sample panel not less than 900 mm long by 900 mm high;
 - (ii) *adobe construction*—a sample comprising not less than 3 blocks, made of the materials and by the methods to be used in the construction, to be provided for inspection on the *site*.
- (b) In the case of *mechanically pressed-soil block construction*—tests, conducted in accordance with Appendix E of *Bulletin 5*, made on blocks of the kind to be used in the construction after they have been moist cured for seven days.

PART **3.4**

FRAMING

- 3.4 Explanation of terms**
- 3.4.1 Sub-floor Ventilation**
- 3.4.2 Steel Framing**
- 3.4.3 Structural Steel Memembrs**

PART 3.4 CONTENTS

PART 3.4 FRAMING

3.4.0 Explanation of Terms

3.4.0.1 Explanation of terms

3.4.1 Sub-Floor Ventilation

3.4.1.1 Application

3.4.1.2 Sub-floor ventilation

3.4.2 Steel Framing

3.4.2.0 Acceptable construction manual

3.4.2.1 Application

3.4.2.2 General

3.4.2.3 Steel floor framing

3.4.2.4 * * *

3.4.2.5 * * *

3.4.2.6 Installation of services

3.4.3 Timber Framing

3.4.3.0 Acceptable construction manual

3.4.3.1 * * *

3.4.3.2 * * *

3.4.3.3 * * *

3.4.3.4 * * *

3.4.3.5 * * *

3.4.3.6 * * *

3.4.3.7 * * *

3.4.3.8 * * *

3.4.4 Structural Steel Members

3.4.4 Explanation of Terms

3.4.4.0 Acceptable construction manuals

3.4.4.1 Application

3.4.4.2 Structural steel members

3.4.4.3 Columns

3.4.4.4 Corrosion protection

PART 3.4.0 EXPLANATION OF TERMS

Explanation of terms

3.4.0.1

The following diagrams depict framing members and associated terminology used to describe them in the *Housing Provisions*.

In most cases the terminology is applicable for both steel and timber frame members.

Figure 3.4.0.1

SPAN AND SPACING TERMS

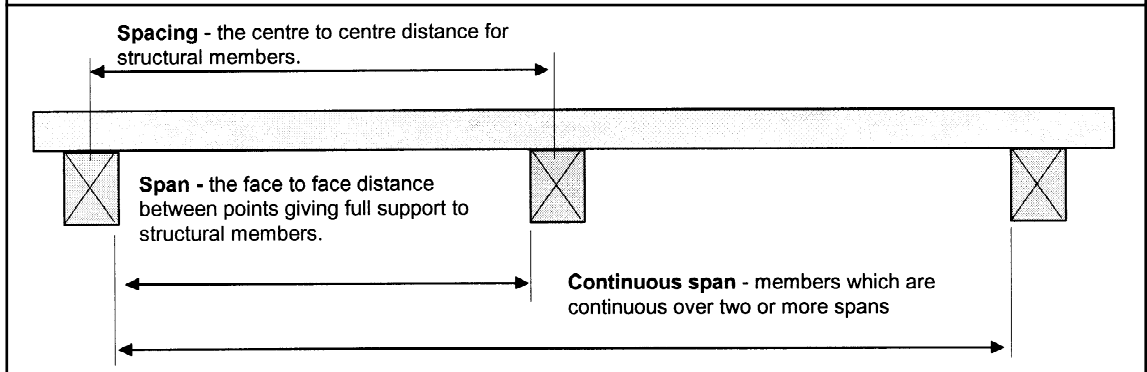

Figure 3.4.0.2

TYPICAL ROOF FRAMING MEMBERS

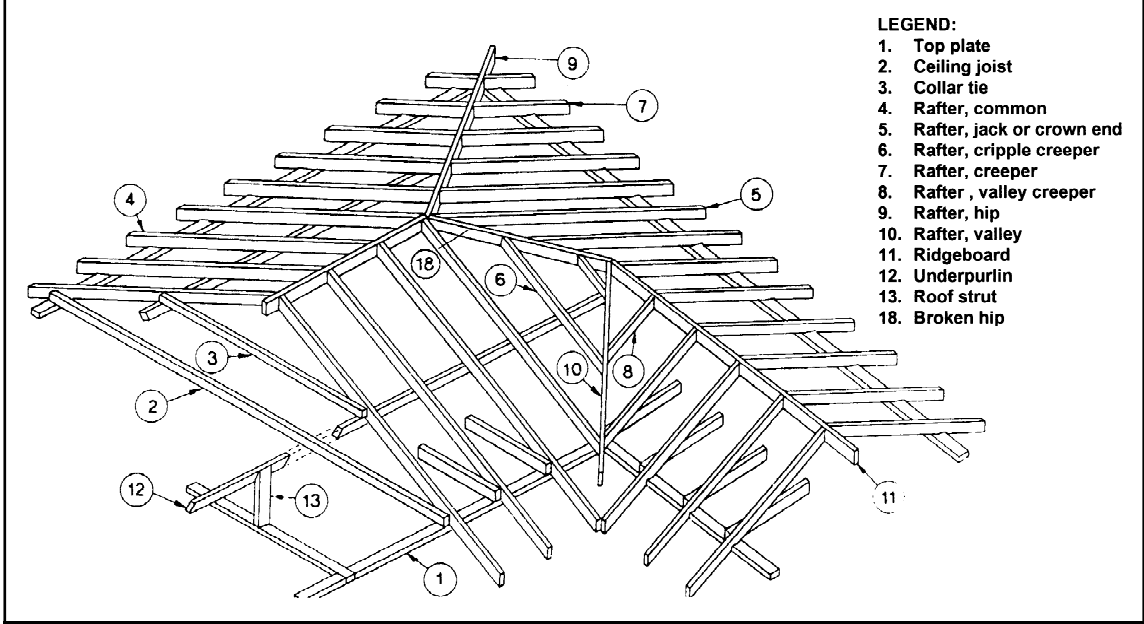
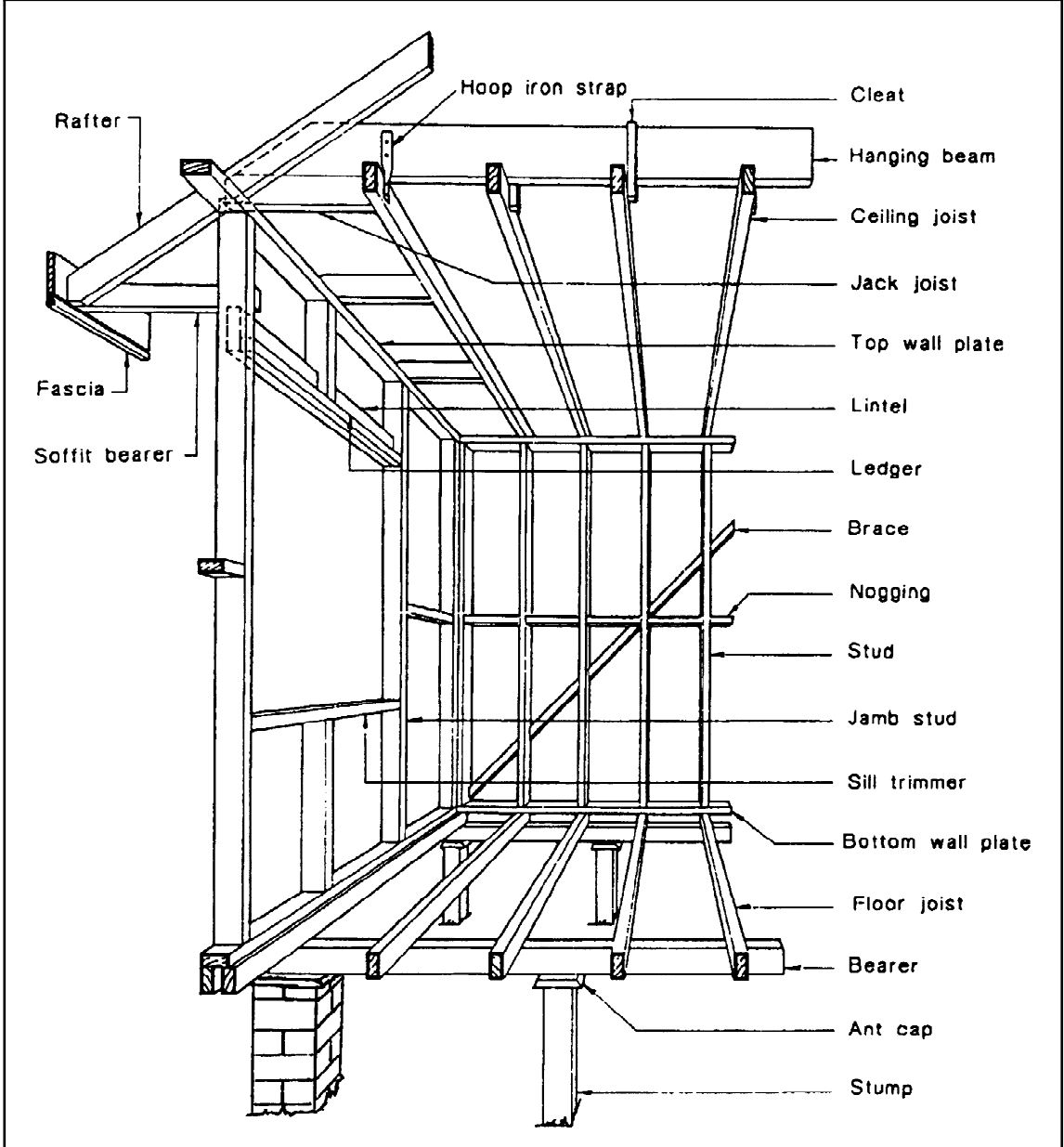

Figure 3.4.0.3
TYPICAL WALL, FLOOR AND CEILING FRAMING MEMBERS



PART 3.4.1 SUB-FLOOR VENTILATION

Appropriate Performance Requirements

Where an alternative sub-floor ventilation system is proposed as an *Alternative Solution* to that described in Part 3.4.1, that proposal must comply with—

- (a) *Performance Requirement* **P2.2.3**; and
- (b) the relevant *Performance Requirements* determined in accordance with **1.0.10**.

Acceptable construction practice

3.4.1.1 Application

Compliance with this Part satisfies *Performance Requirement* **P2.2.3** for sub-floor ventilation.

3.4.1.2 Sub-floor ventilation

The sub-floor space between a suspended floor of a building and the ground must be in accordance with the following:

- (a) The sub-floor space must—
 - (i) be cleared of all building debris and vegetation; and
 - (ii) be cross-ventilated by means of openings; and
 - (iii) contain no dead air spaces; and
 - (iv) be graded in accordance with **3.1.2.3**; and
 - (v) have evenly spaced ventilation openings in accordance with **Figure 3.4.1**, Diagram a.
- (b) In double leaf masonry walls, the cross ventilation openings specified in (a) must be provided in both leaves of the masonry, with inner-leaf openings being aligned with outer leaf openings to allow an unobstructed flow of air.
- (c) Internal walls constructed in sub-floor spaces must be provided with openings—
 - (i) having an unobstructed area equivalent to that *required* for the adjacent external openings; and
 - (ii) which are evenly distributed throughout such internal walls.
- (d) The clearance between the ground surface and the underside of the floor, must be in accordance with **Table 3.4.1.2**.
- (e) The sub-floor ventilation openings in internal and *external walls* must be in accordance with **Table 3.4.1.2** for the climatic zones given in **Figure 3.4.1.2**.
- (f) Where ventilation is obstructed by patios, paving or the like, additional ventilation must be provided to ensure that the overall level of ventilation is maintained.

- (g) Where the ground or sub-floor space is excessively damp or subject to frequent flooding, in addition to the requirements of (a) to (f)—
- (i) the area of sub-floor ventilation *required* in (e) must be increased by 50%; or
 - (ii) a sealed impervious membrane must be provided over the ground; or
 - (iii) Durability Class 1 or 2 timbers or H3 preservative treated timbers in accordance with AS 1684 Parts 2, 3 or 4.

Figure 3.4.1

TYPICAL SUB-FLOOR VENTILATION DETAILS

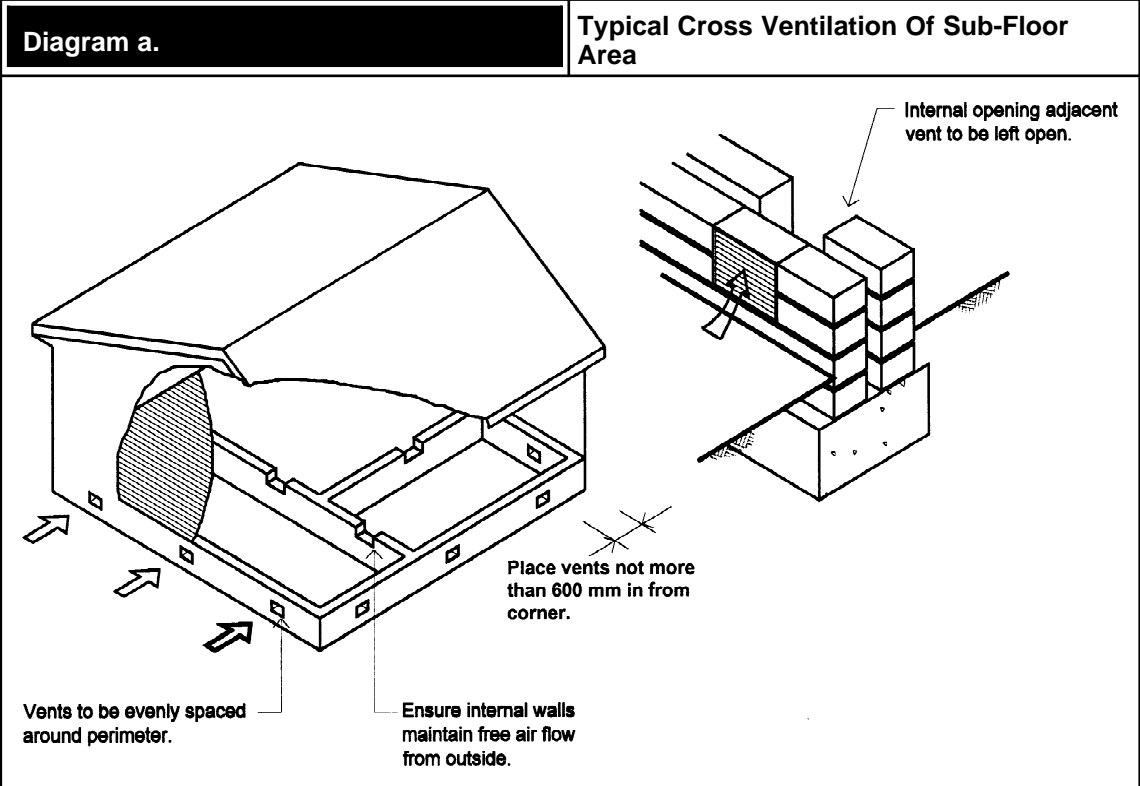

Figure 3.4.1

TYPICAL SUB-FLOOR VENTILATION DETAILS

Note:	(a)	400 mm clearance required only where termite barriers are installed that need to be inspected (see Part 3.1.3).
	(b)	On sloping sites, 400 mm clearance may be reduced to 150 mm within 2 m of external walls in accordance with Diagram b.

Diagram b.	Sub-Floor Clearance Requirements
-------------------	---

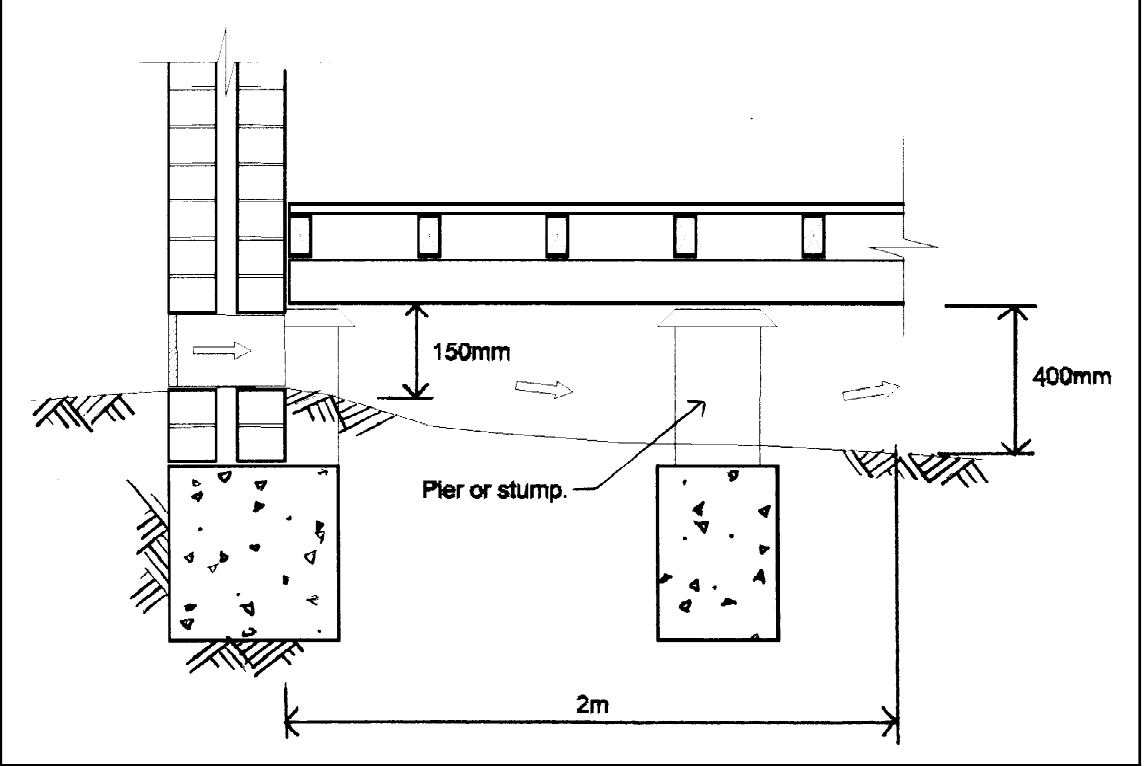

Figure 3.4.1.2
CLIMATIC ZONES BASED ON RELATIVE HUMIDITY

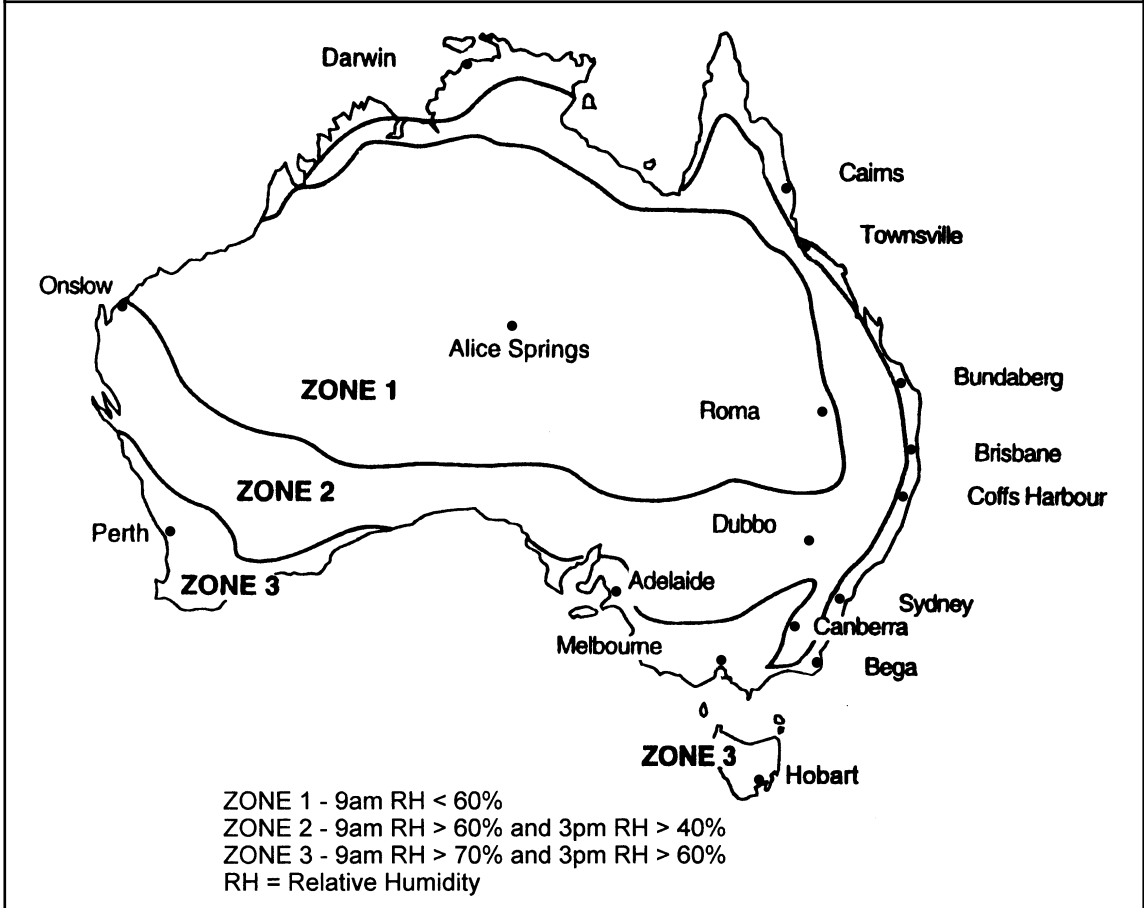

Table 3.4.1.2 SUB-FLOOR VENTILATION AND CLEARANCE

CLIMATE ZONE (see Figure 3.4.1.2)	Minimum sub-floor ventilation (mm ² /m of wall)		Minimum height from ground surface (mm)	
	No membrane	Ground sealed with impervious membrane	Termite inspection not required	Termite inspection required (see note)
1	2000	1000	150	400
2	4000	2000	150	400
3	6000	3000	150	400

Note: On sloping sites, 400 mm clearance may be reduced to 150 mm within 2 m of *external walls* in accordance with [Figure 3.4.1](#) Diagram b.

Explanatory information:

The amount of sub-floor ventilation required for a building is related to the relative humidity likely to be encountered in that location. [Figure 3.4.1.2](#) shows three broad climatic zones

based on the prevailing relative humidity and includes a description of the relative humidity conditions which define each zone. If reliable weather data is available, these descriptions may be useful in determining which zone a particular location is in.

The zones shown in **Figure 3.4.1.2** were determined by analysis of the average relative humidity at 9 am and 3 pm in January and July. The season with the highest relative humidity is used. Generally this will be July for southern Australia and January for northern Australia.

PART 3.4.2 STEEL FRAMING

Appropriate Performance Requirements

Where an alternative steel framing system is proposed as an *Alternative Solution* to that described in Part 3.4.2, that proposal must comply with—

- (a) *Performance Requirement P2.1*; and
- (b) the relevant *Performance Requirements* determined in accordance with **1.0.10**.

A. Acceptable construction manual

3.4.2.0

Performance Requirement P2.1 is satisfied for cold formed steel framing if it is designed and constructed in accordance with one of the following manuals:

- (a) AS 3623—Domestic metal framing.
- (b) AS 4100—Steel structures.
- (c) AS/NZS 4600—Cold-formed steel structures.

Explanatory information:

Design requirements for other materials used in combination with steel framing, including the use of concrete floors, heavy steel support beams etc are described in **Part 3.11**—Structural design; or **Part 3.4.4** for structural steel members.

B. Acceptable construction practice

3.4.2.1 Application

Compliance with this Part satisfies *Performance Requirement P2.1* for steel framing, provided—

- (a) the frame is cold-formed metal framing designed and constructed in accordance with AS 3623 or AS/NZS 4600; and
- (b) the frame material has a yield stress of not less than 250 MPa.

3.4.2.2 General

- (a) The steel frame must be protected from corrosion in accordance with the following:
 - (i) Where the steel frame is within the building envelope, in locations—
 - (A) more than 300 m from breaking surf, or

- (B) not in a heavy industrial area; or
- (ii) Where the steel frame is outside the building envelope—in locations—
 - (A) more than 1 km from salt water which is not subject to breaking surf, such as a lake or protected bay; or
 - (B) more than 10 km from a coastal area with breaking surf; or
 - (C) not in a heavy industrial area,
 the steel frame must have a minimum coating class in accordance with AS 1397 of Z275 (275 grams of zinc per square metre) or AZ150 (150 grams of aluminium/zinc per square metre).
- (iii) In areas not specified in (i) or (ii), a higher level of corrosion protection is *required*.
- (b) The frame must be permanently electrically earthed on completion of fixing.

Explanatory information:

The steel frame requirements of this Part should be considered in conjunction with steel frame design and construction advice from the manufacturer.

For the purpose of 3.4.2.2, the building envelope is deemed to be a space in the building where the steel frame does not have direct contact with the external atmosphere, other than for normal ventilation purposes. Examples of such locations are frames which are clad or lined on both sides or frames in masonry veneer construction. Areas not within the building envelope include floor framing members where there is no continuous perimeter sub-floor walling or verandah roof framing members with no ceiling lining.

Cut edges on framing components do not constitute a corrosion problem, as the surface area of the metallic coating on either side of the cut edge is far greater than the surface area of the cut edge itself.

Where hole cutting or cutting of members is required, cutting methods that clearly shear or leave clean edges are preferred over those that leave burred edges or swarf.

The adoption of appropriate brick cleaning measures will ensure no damage of any metal or metallic coated components, this would include the shielding of these components during the acid cleaning process. Channels to steel framing should be cleaned of mortar droppings.

Metallic coated steel should not come into contact with green wood containing acidic material or CCA treated timbers unless an impervious non-conductive material is located between the dissimilar elements. The use of kiln or appropriately dried timbers is recommended where contact between the metallic coated steel component and timber is considered.

3.4.2.3 Steel floor framing

The following provisions apply to suspended steel floor framing for single-storey and both floors of two-storey construction:

- (a) The two types of suspended floor systems referred to in 3.4.2.3 are—
 - (i) in-plane systems, such as joist-only systems or systems with integral bearers; and
 - (ii) conventional joist-over-bearer systems (see Tables 3.4.2.1 and 3.4.2.2 for acceptable sizes and spacings).
- (b) When used in ground floor construction, all such systems must be installed on stumps, piers or masonry footings complying with Part 3.2. Conventional flooring can be installed on top of the floor frame.

- (c) Fibre cement packers or similarly durable and compatible materials may be used when packing is necessary under suspended flooring systems and must be at least the width of the member to ensure adequate bearing capacity.

Table 3.4.2.1 SPANS FOR C-SECTION FLOOR JOISTS

SPAN	SECTION	Maximum Joist spacing (mm)	
		450	600
		Maximum span (mm)	
Single span	C15012	2.7	2.7
	C15015	3.3	3.0
	C15019	3.6	3.3
	C20015	4.5	3.9
	C20019	4.8	4.2
	C20024	5.1	4.5
Continuous span	C15012	4.2	3.0
	C15015	4.5	4.2
	C15019	4.8	4.5
	C20015	5.4	4.8
	C20019	5.7	5.4
	C20024	6.0	5.7

Explanatory information:

The size of C-section steel members are identifiable by their description. For example, a C15012 is 150 mm deep and is made from 1.2 mm thick steel.

Table 3.4.2.2 SPANS FOR C-SECTION BEARERS

Steel Section	SINGLE SPAN					CONTINUOUS SPAN				
	Effective Bearer Spacing (m)					Effective Bearer Spacing (m)				
	1.8	2.4	3.0	3.6	4.2	1.8	2.4	3.0	3.6	4.2
	MAXIMUM SPAN OF BEARER (m)					MAXIMUM SPAN OF BEARER (m)				
C15015	2.2	2.1	1.9	1.8	1.7	2.7	2.5	2.4	2.3	2.1
C15019	2.4	2.2	2.0	1.9	1.8	2.9	2.7	2.5	2.4	2.2
C20015	2.9	2.7	2.4	2.1	1.8	3.4	2.7	2.4	2.1	1.8
C20019	3.1	2.9	2.7	2.5	2.4	3.8	3.5	3.3	3.2	3.0
C25019	3.6	3.4	3.2	3.0	2.6	4.6	3.8	3.4	3.0	2.6
C25024	3.9	3.7	3.4	3.3	3.0	4.8	4.6	4.2	4.1	3.8

Steel Section	SINGLE SPAN					CONTINUOUS SPAN				
	Effective Bearer Spacing (m)					Effective Bearer Spacing (m)				
	1.8	2.4	3.0	3.6	4.2	1.8	2.4	3.0	3.6	4.2
	MAXIMUM SPAN OF BEARER (m)					MAXIMUM SPAN OF BEARER (m)				
Note:	For the purpose of this Table:									
	(a)	Loads must be evenly distributed along the member.								
	(b)	Sections must be stiffened at end supports.								

Figure 3.4.2.1

TYPICAL JOIST OVER BEARER FLOORING SYSTEM

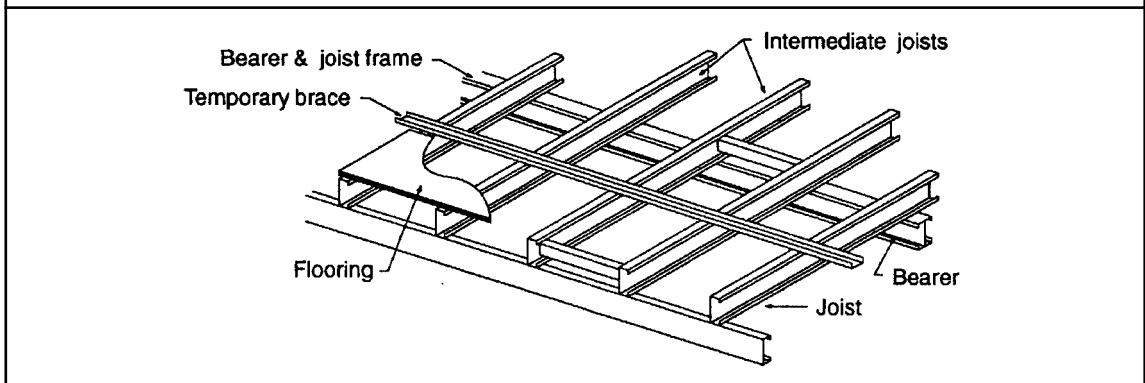

3.4.2.4 * * *

This clause has deliberately been left blank.

3.4.2.5 * * *

This clause has deliberately been left blank.

3.4.2.6 Installation of services

To maintain the structural integrity of the frame, all ancillary work must be in accordance with the following:

- (a) Service penetrations in floor joists must comply with [Figure 3.4.2.8](#).
- (b) Plumbing pipe-work in steel framed construction must be run in the following ways:
 - (i) Pipe-work must be—
 - (A) run through pre-punched service holes in steel studs; and
 - (B) extra holes, where necessary, must be located near the centre-line of each stud provided—
 - (aa) the structural integrity of the member is not reduced; and
 - (bb) the hole is not more than 10% larger than the existing holes.

- (ii) In masonry veneer construction, pipe runs may be located in the *cavity* and fixed to the studs with full pipe saddles and self drilling screws properly protected against galvanic corrosion in accordance with (v).
- (iii) In construction where external cladding is attached directly to the steel stud work, piping can be—
 - (A) installed over the ceiling; or
 - (B) suspended under the floor; or
 - (C) installed in accordance with (i).
- (iv) Plumbing fittings may be attached by—
 - (A) timber or steel noggings fitted between studs to support tap sets, baths and sinks; and
 - (B) where a steel nogging is used, the tap set must be isolated to prevent corrosion by a durable non corrosive material such as timber, cement sheet etc (see [Figure 3.4.2.7](#)).
- (v) Copper and brass pipes and fittings must be prevented from coming into contact with the steel frame by one of the following methods:
 - (A) Where plumbing services pass through service holes, plastic grommets must be snapped into the service hole.

Explanatory information:

The use of grommets also has the effect of securely fixing the pipe to prevent water hammer.

- (B) In other areas where copper pipes may come into contact with metal framing, they must be lagged or isolated with neoprene sheeting or tape.
- (c) Electrical cables must be—
- (i) run through pre-punched service holes in steel studs (see [Figure 3.4.2.7](#)); or
 - (ii) secured to steel framing with—
 - (A) P clips; or
 - (B) plastic ratchet straps; or
 - (C) half saddles fixed with screws or rivets; and
 - (iii) extra holes, where necessary, must comply with (b)(i)(B); and
 - (iv) steel frames must be permanently earthed immediately after the frame is erected; and
 - (v) backing plates for switches and power points should be fixed at the appropriate positions with suitable fasteners. Where it is impractical to fix directly onto studwork, steel or timber noggings can be fitted between the studs to provide necessary fixing and support.

Figure 3.4.2.7

TYPICAL INSTALLATION AND FIXING OF SERVICES

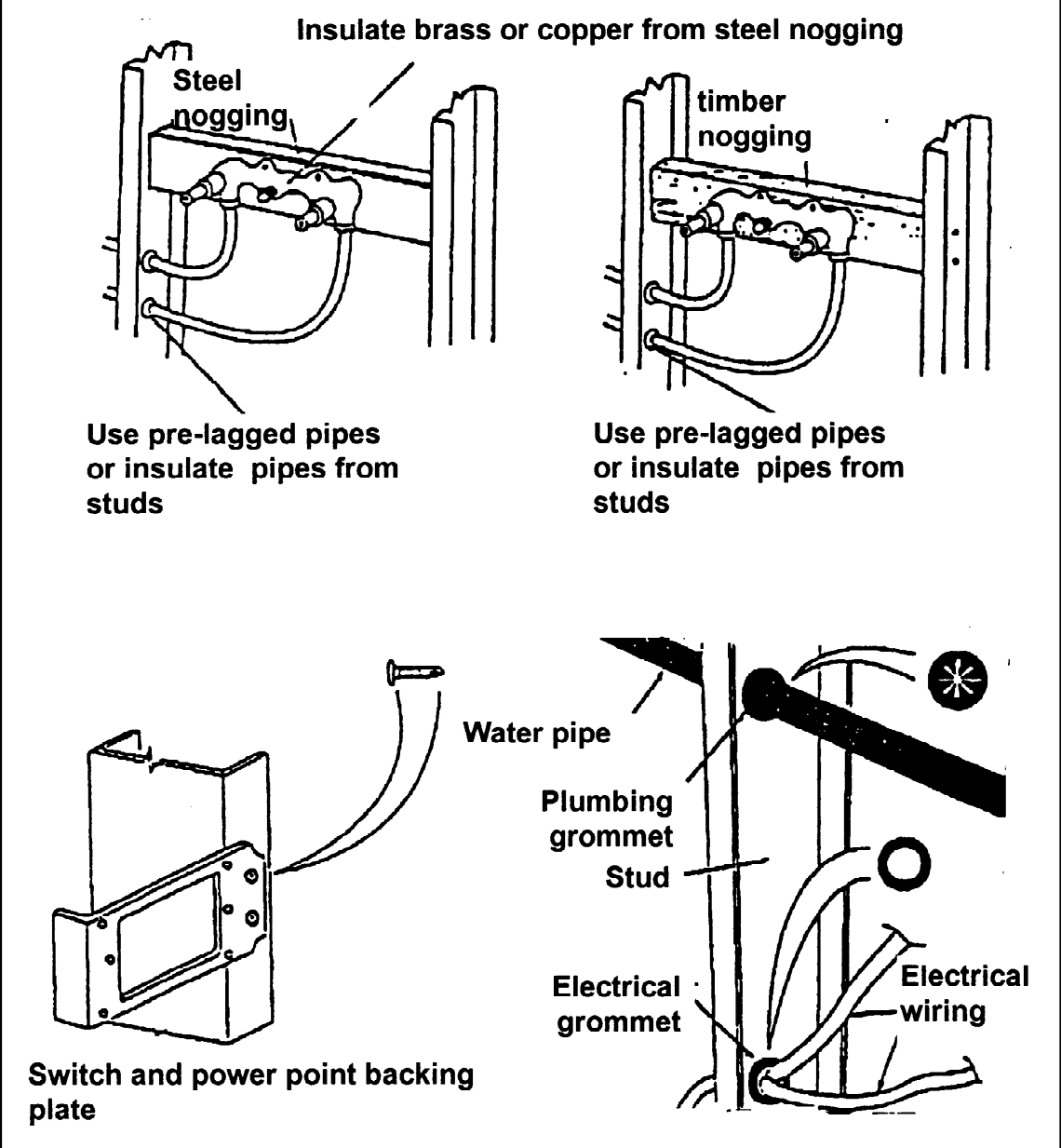

Explanatory information:

There are many different types of steel framing systems available. Each of these systems have unique design and installation requirements. Due to this diversity, there are no generic examples of acceptable construction practice for steel wall and roof framing. Accordingly, the design of these systems must be in accordance with the appropriate acceptable construction manual in [3.4.2.0](#).

Some of the important elements of steel frame design are contained in the following information.

Wall framing

Frames are either in rigid or adjustable form. In the case of rigid frames, minor irregularities in flooring are accommodated by packing.

With adjustable frames, the tensioner assembly on the bracing can usually be adjusted to accommodate these irregularities. After tensioning, bracing straps should be securely fixed to each stud and nogging.

Long runs of external walling may have to be temporarily braced, until the roof members have been fixed. This can be carried out by using lengths of steel, timber or roof battens fixed to the top of the studs and secured to the ground or floor, as temporary props.

Further construction stage bracing may be required to be installed before roof cladding commences. This is required to prevent side sway of the building during construction.

Construction bracing should be provided in the following minimum percentage of required vertical bracing:

40% single storey slab-on-ground buildings;

40% upper storey of buildings with suspended floors;

50% lower storey of 2 storey construction.

Roof framing

Trusses and rafters are fixed in accordance with the design details. Generally, the roof members are fixed to the wall structure using conventional building methods.

The fixings may incorporate nails, self-drilling screws, bolts and nuts or shear plate connectors. The fixings should be adequate to ensure that a continuous load path exists from the roof to the foundations for all types of loading including uplift, downward and shear loading.

Temporary roof bracing is generally achieved using one run of roof battens along the full length of the house. It is preferable if the run nearest the roof apex is used for this purpose and fixed as each truss is properly positioned. Next, one run of ceiling battens should be positioned and fitted. This should preferably be the batten run nearest the centre of the building.

Where ceiling battens are not used a bottom chord tie should be installed in accordance with the design details.

Wind bracing should be attached when all trusses have been erected and fixed. Generally all gable roofs and long hipped roofs require bracing in the roof plane. The strap bracing is installed similar to wall bracing and runs from the apex of the roof to the external wall, over the top of at least three trusses or rafters, at approximately 45° to the *external walls*. The bracing is fixed at the ends, tensioned and fixed to each intermediate truss or rafter.

Connections for steel framing

The following fasteners and connections are acceptable for the assembly and erection of steel framed houses:

Bolts: Bolted connections are used as a means of on-site jointing, particularly where joints are highly loaded and offer a consistent design strength. Bolt design for cold-formed sections is adequately covered in the Australian Standards.

Rivets: Riveted connections (either pre-drilled or self-piercing) are used for both factory and on-site fabrication and have also been used as elements of proprietary joining systems.

Screw: Self-drilling screws are widely used as a means of connection in almost every aspect of on-site work during the erection of steel framed houses. They are used for connecting wall frame modules, through to attachment of claddings and internal linings.

Adhesives: Adhesives are used in steel framing for attachment of internal linings, including flooring. They are generally used in combination with mechanical fasteners such as self-drilling screws. The screws are primarily used to fasten the linings while the adhesives set, although they continue to act as part of a composite fastening system.

Clinches: Clinching involves the connection of two thicknesses of sheet steel by extruding one sheet into the other using a punch and die, in such a way that the two pieces cannot be subsequently separated. A typical clinched joint used in factory fabrication is usually hydraulically activated whereas clinching systems used on-site are typically pneumatic or electrically driven.

Welds: Welding (typically Mig) has been the most common form of connection during factory assembly for many years. The welded joint strength can vary and the metallic coating is affected in the weld area, the affected area will require post-painting (cold galvanising).

Nails: Hard steel twist nails are used in steel framing for both factory and on-site fabrication. These nails can be used in materials up to 2 mm thick. Nails have also been used for the connection of wall plates to concrete slabs. Where this is done by hand, a timber starter block is normally used. More recently, power actuated nails have been used.

Figure 3.4.2.8

ACCEPTABLE PENETRATIONS TO STEEL FLOOR JOISTS

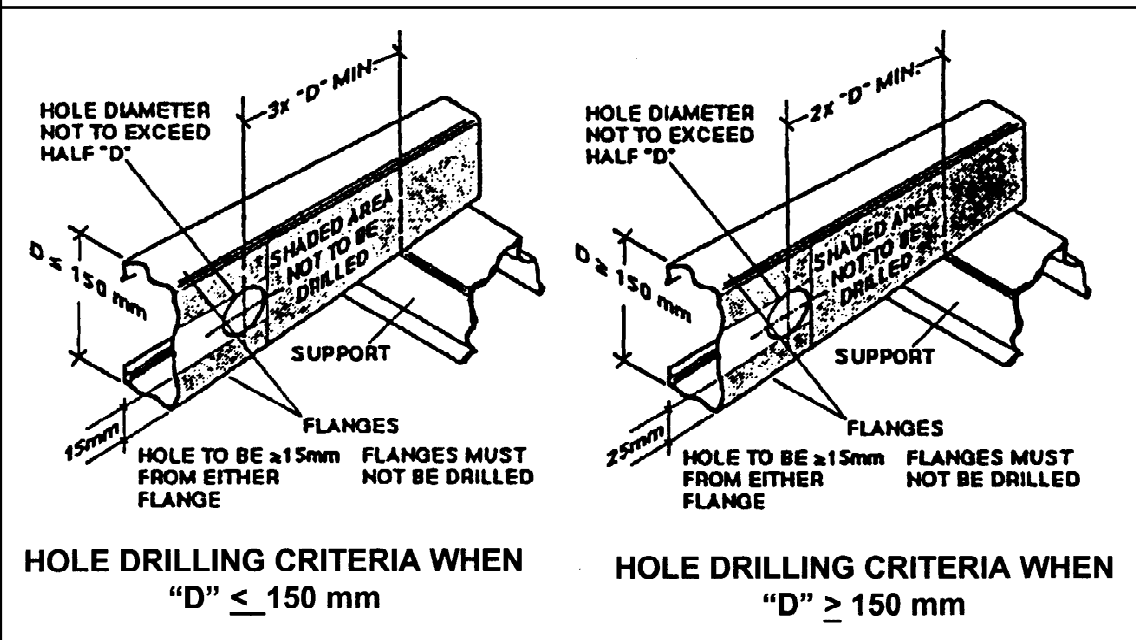

PART 3.4.3 TIMBER FRAMING

Appropriate Performance Requirements

Where an alternative timber framing design is proposed as an *Alternative Solution* to that described in Part 3.4.3, that proposal must comply with—

- (a) *Performance Requirement P2.1*; and
- (b) the relevant *Performance Requirements* determined in accordance with **1.0.10**.

A. Acceptable construction manual

3.4.3.0

Performance Requirement P2.1 is satisfied for a timber frame if it is designed and constructed in accordance with one of the following manuals:

- (a) * * *
- (b) * * *
- (c) * * *
- (d) * * *
- (e) * * *
- (f) * * *
- (g) AS 1684.2—Residential timber-framed construction—Non-cyclonic areas.
- (h) AS 1684.4—Residential timber-framed construction—Simplified—Non-cyclonic areas.

STATE AND TERRITORY VARIATIONS

In Queensland after 3.4.3.0(h) insert Qld 3.4.3.0(i) as follows:

Qld 3.4.3.2(i) Timber Species

- (i)
 - Timber Species
 - In addition to subclauses (a) to (h) above, timber used for structural purposes must be a species scheduled for the appropriate use in Schedules A, B or C in Queensland Forest Service of the Department of Primary Industries Technical Pamphlet No. 1—Building Timbers, Properties and Recommendations for their Use in Queensland.

Explanatory information:

1. Design requirements for other materials used in combination with timber framing, including the use of concrete floors, heavy steel support beams etc are described in [Part 3.11](#)—Structural design; or [Part 3.4.4](#)—Structural steel members.
2. For additional construction requirements in *high wind areas* (ie >W41), see [Part 3.10.1](#).

B. Acceptable construction practice**3.4.3.1 * * ***

This clause has deliberately been left blank.

3.4.3.2 * * *

This clause has deliberately been left blank.

3.4.3.3 * * *

This clause has deliberately been left blank.

3.4.3.4 * * *

This clause has deliberately been left blank.

3.4.3.5 * * *

This clause has deliberately been left blank.

3.4.3.6 * * *

This clause has deliberately been left blank.

3.4.3.7 * * *

This clause has deliberately been left blank.

3.4.3.8 * * *

This clause has deliberately been left blank.

PART 3.4.4 STRUCTURAL STEEL MEMBERS

Appropriate Performance Requirements

Where an alternative structural steel member system is proposed as an *Alternative Solution* to that described in Part 3.4.4, that proposal must comply with—

- (a) *Performance Requirement P2.1*; and
- (b) the relevant *Performance Requirements* determined in accordance with **1.0.10**.

Explanation of Terms

3.4.4

The following terms are used in this Part:

Figure 3.4.4.0		
EFFECTIVE MEMBER SPACING FOR STRUCTURAL STEEL BEARERS AND STRUTTING BEAMS		
Diagram a.	Single spanning rafter or joist	
Design member	Member 1	Member 2
Effective member spacing	$0.5 \times \text{Span 1}$	$0.5 \times (\text{Span 1} + \text{Span 2})$

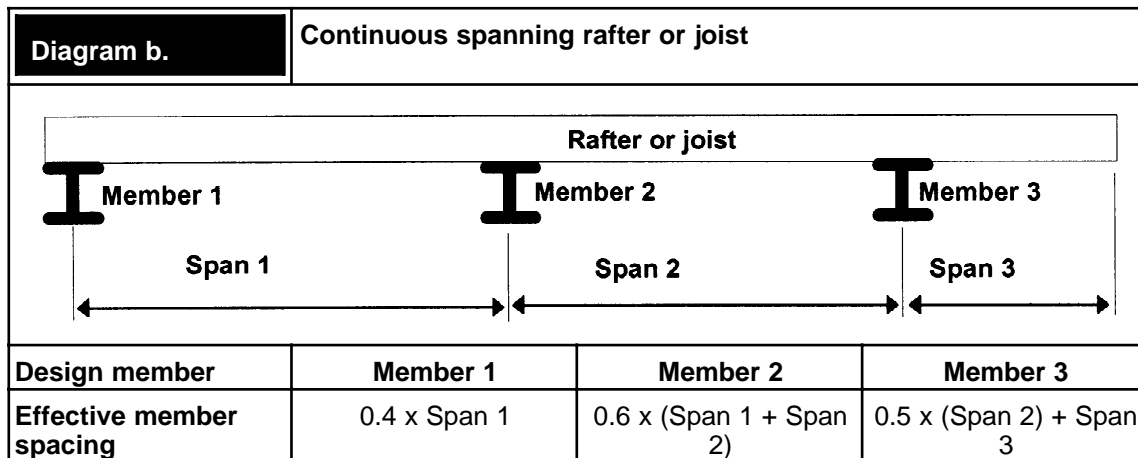

Steel member abbreviations are as follows:

TFB means a tapered flange beam.

UB means a universal beam.

RHS means a rectangular hollow section.

PFC means a parallel flange channel.

TFC means a tapered flange channel.

EA means an equal angle.

UA means an unequal angle.

SHS means a square hollow section.

CHS means a circular hollow section.

A. Acceptable construction manuals

3.4.4.0

Performance Requirement P2.1 is satisfied for structural steel sections if they are designed and constructed in accordance with one of the following manuals:

- (a) AS 4100—Steel structures.
- (b) AS/NZS 4600—Cold-formed steel structures.

Explanatory information:

Design requirements for other materials used in combination with structural steel members are described in [Part 3.4.2](#), [3.4.3](#) or [Part 3.11](#)—Structural design.

B. Acceptable construction practice

3.4.4.1 Application

- (a) Compliance with this Part satisfies **P2.1** in respect to structural stability, provided—
- (i) the building is located in an area with a *design wind speed* of not more than W41; and

Explanatory information:

1. Information on *design wind speeds* for particular areas may be available from the *appropriate authority*.
2. A map indicating cyclonic regions of Australia is contained in **Part 3.10.1**.

- (ii) the first dimension of steel sections is installed vertically; and
- (iii) all loads are uniformly distributed (unless otherwise noted or allowed for); and
- (iv) for earthquake design, the building is defined as a design category H1 or H2 domestic structure in accordance with AS 1170.4; and

Explanatory information:

1. This covers all *sites* except those identified by the site investigation as having soft soil (having a soil profile with more than 5 m of soft clay, loose sand, silt or uncontrolled fill) as defined by AS 1170.4.
2. For earthquake design H3, see **Part 3.10.2**.

- (v) the structural steel member is not subject to snow loads.
- (b) Compliance with **3.4.4.4** satisfies **P2.1** in respect to corrosion protection requirements.

3.4.4.2 Structural steel members

- (a) Structural steel members may be used as follows:
- (i) Bearers supporting a timber floor or non-loadbearing stud wall—in accordance with **Figure 3.4.4.1**.
- (ii) Strutting beams supporting roof and ceiling loads—in accordance with **Figure 3.4.4.2**.
- (iii) Lintels supporting roof, ceiling, frame and timber floor—in accordance with **Figure 3.4.4.3**.
- (iv) Columns—in accordance with **3.4.4.3**.
- (b) Structural steel members described in this Part must be protected against corrosion in accordance with **3.4.4.4**.
- (c) Joists, bearers and lintels must be restrained from lateral movement or twisting along their length by fixing rafters or joists to the top flange of the member so that it prevents that member from moving laterally.
- (d) End supports for joists, bearers and lintels must transfer loads to the footings and have a bearing distance as follows:

- (i) For single spans, the bearing distance must not be less than the width of the member.
- (ii) For continuous spans, internal bearing must be not less than 2 times the width of the member.

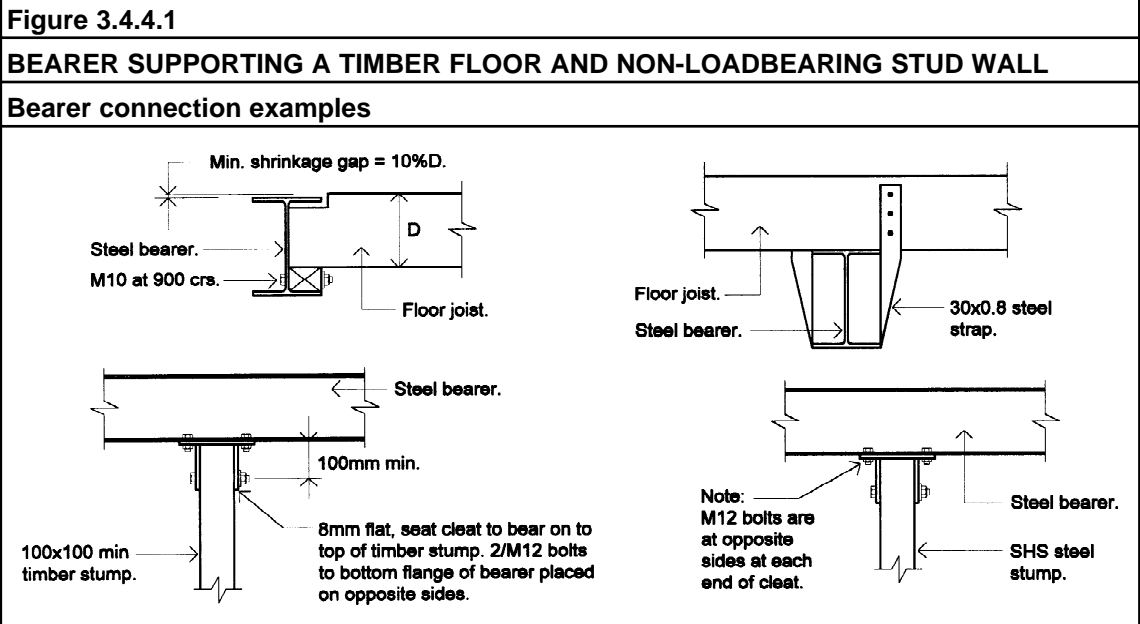

Table a.—Acceptable bearer spans

Steel Section	SINGLE SPAN					CONTINUOUS SPAN				
	<i>Effective Bearer Spacing (m)</i>					<i>Effective Bearer Spacing (m)</i>				
	1.8	2.4	3.0	3.6	4.2	1.8	2.4	3.0	3.6	4.2
	MAXIMUM SPAN OF BEARER (M)					MAXIMUM SPAN OF BEARER (M)				
125TFB	4.1	3.8	3.6	3.4	3.2	4.7	4.3	3.8	3.5	3.2
180UB16.1	5.1	4.7	4.5	4.3	4.1	5.9	5.5	5.2	5.0	4.7
200UB18.2	5.6	5.2	5.0	4.7	4.6	6.5	6.0	5.7	5.5	5.3
250UB25.7	6.8	6.4	6.0	5.8	5.6	7.9	7.4	7.0	6.7	6.4
250x150x9.0 RHS	7.7	7.1	6.7	6.4	6.2	8.8	8.2	7.8	7.4	7.1
250x150x5.0 RHS	6.8	6.3	5.9	5.7	5.5	7.8	7.2	6.8	6.5	6.3
310UB32.0	7.9	7.3	7.0	6.7	6.4	9.1	8.5	8.1	7.7	7.4
125x75x2.0 RHS	3.1	2.8	2.6	2.5	2.4	4.0	3.7	3.5	3.3	3.1
125x75x3.0 RHS	3.5	3.2	3.0	2.8	2.7	4.4	4.1	3.9	3.7	3.5
150x50x2.0 RHS	3.4	3.1	2.8	2.7	2.5	4.2	3.9	3.7	3.5	3.4
150x50x3.0 RHS	3.7	3.4	3.2	3.0	2.9	4.6	4.3	4.1	3.9	3.7
100TFC	3.2	2.9	2.7	2.6	2.4	3.7	3.2	2.8	2.6	2.4
150PFC	4.8	4.5	4.2	4.0	3.9	5.5	5.1	4.9	4.7	4.5

Figure 3.4.4.1

BEARER SUPPORTING A TIMBER FLOOR AND NON-LOADBEARING STUD WALL

Bearer connection examples

180PFC	5.4	5.1	4.8	4.6	4.4	6.3	5.9	5.6	5.3	5.1
200PFC	5.9	5.5	5.2	5.0	4.8	6.8	6.3	6.0	5.7	5.50
250PFC	7.2	6.7	6.4	6.1	5.9	8.4	7.8	7.4	7.1	6.8
300PFC	8.1	7.6	7.2	6.9	6.6	9.4	8.8	8.3	8.0	7.7

Notes:

1. Steel is base grade.
2. Load must be evenly distributed along the member.
3. For continuous floor bearers, the variation in span length should not be more than 10%.
4. See 3.4.2.3 for provisions that apply to suspended floors in single storey and ground floor construction of suspended steel floor frames.
5. Effective bearer spacing is a measure of the width of the load area being supported by the member (see Figure 3.4.4.0).

Figure 3.4.4.2

STRUTTING BEAM SUPPORTING A ROOF AND CEILING

Strutting beam application

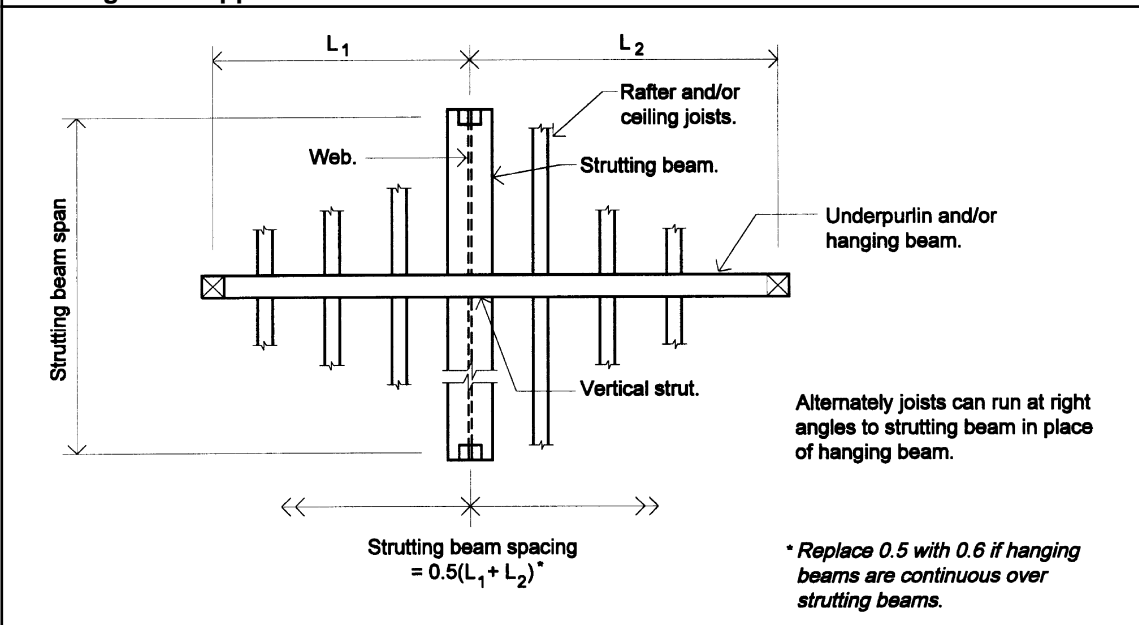

Figure 3.4.4.2										
STRUTTING BEAM SUPPORTING A ROOF AND CEILING										
Strutting beam application										
Table a.—Acceptable strutting beam spans										
Steel Section	STEEL SHEET ROOF					TILED ROOF				
	<i>Strutting Beam Spacing (m)</i>					<i>Strutting Beam Spacing (m)</i>				
	1.8	2.4	3.0	3.6	4.2	1.8	2.4	3.0	3.6	4.2
	MAXIMUM SPAN OF STRUTTING BEAM (M)					MAXIMUM SPAN OF STRUTTING BEAM (M)				
125TFB	5.7	5.4	5.1	4.9	4.6	4.9	4.6	4.4	4.2	4.1
150UB14.0	6.4	6.0	5.7	5.4	5.1	5.5	5.2	4.9	4.7	4.5
200UB18.2	7.9	7.4	7.1	6.8	6.5	6.9	6.4	6.1	5.8	5.6
250UB31.4	10.0	9.4	9.0	8.7	8.4	8.8	8.2	7.8	7.5	7.2
310UB46.2	11.9	11.3	10.8	10.5	10.1	10.6	10.0	9.5	9.1	8.8
100TFC	4.6	4.4	4.2	3.9	3.7	4.0	3.7	3.6	3.4	3.2
150PFC	6.7	6.3	6.0	5.8	5.6	5.8	5.5	5.2	5.0	4.8
200PFC	8.2	7.7	7.4	7.1	6.8	7.2	6.7	6.4	6.1	5.9
250PFC	10.0	9.4	9.0	8.7	8.4	8.8	8.2	7.8	7.5	7.3
300PFC	11.1	10.5	10.1	9.7	9.4	9.8	9.3	8.8	8.4	8.2
Note:										
1.	If point load applied, then it should be located within the middle third of the strutting beam span.									
2.	Top and bottom flanges of strutting beam must be laterally restrained at the loading point.									
3.	Strutting beam must be tied down at the support points, in the case of steel sheet roofs.									
4.	Steel is base grade.									

Figure 3.4.4.3

LINTELS SUPPORTING ROOF, FRAMES AND TIMBER FLOORS

Lintels supporting roof and floors

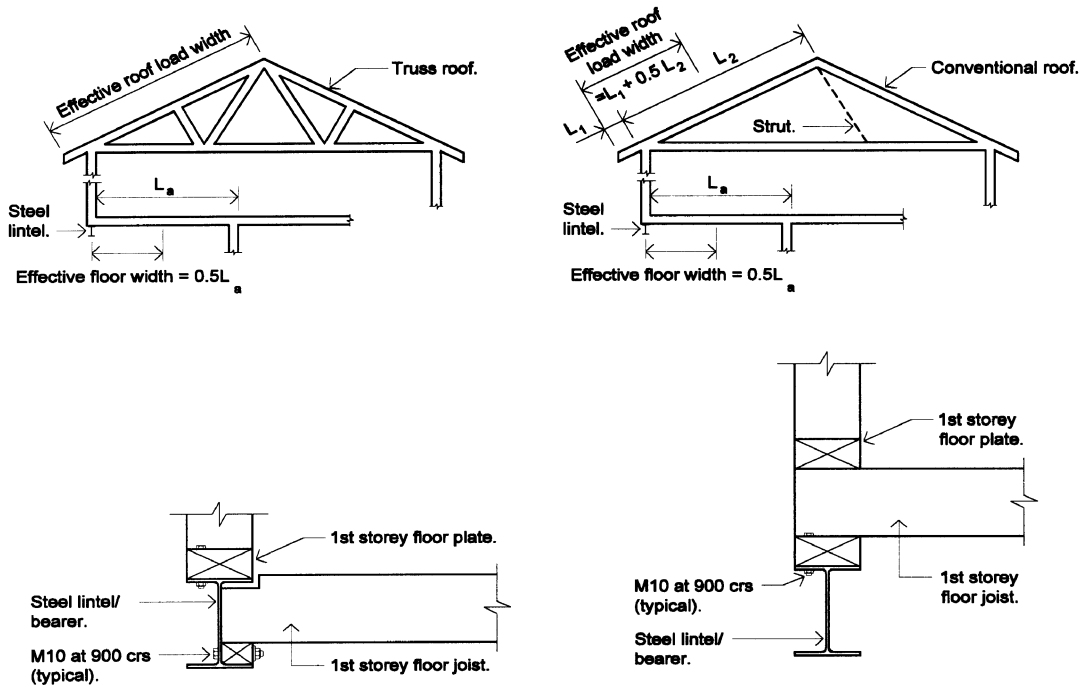

Table a.—Acceptable spans for lintels

Steel Section	STEEL SHEET ROOF					TILED ROOF				
	Effective Load Width (m)					Effective Load Width (m)				
	1.8	2.4	3.0	3.6	4.2	1.8	2.4	3.0	3.6	4.2
	MAXIMUM SPAN OF LINTEL (M)					MAXIMUM SPAN OF LINTEL (M)				
125TFB	3.7	3.4	3.2	3.0	2.8	3.6	3.3	3.0	2.9	2.7
150UB14.0	4.1	3.9	3.7	3.5	3.3	4.0	3.7	3.5	3.3	3.2
200UB25.4	5.6	5.3	5.0	4.8	4.7	5.4	5.1	4.8	4.6	4.5
250UB31.4	6.6	6.2	5.9	5.7	5.5	6.3	6.0	5.7	5.4	5.2
100TFC	2.8	2.6	2.4	2.3	2.1	2.7	2.5	2.3	2.1	2.0
150PFC	4.4	4.1	3.9	3.7	3.6	4.2	3.9	3.7	3.6	3.4
200PFC	5.4	5.0	4.8	4.6	4.4	5.1	4.8	4.6	4.4	4.2
250PFC	6.6	6.2	5.9	5.7	5.5	6.3	6.0	5.7	5.4	5.3
75x75x5EA	1.3	1.2	1.1	—	—	1.3	1.1	—	—	—
90x90x6EA	1.9	1.6	1.5	1.3	1.2	1.7	1.5	1.4	1.3	1.2
100x100x6EA	2.0	1.8	1.6	1.5	1.4	1.9	1.7	1.5	1.4	1.3

Figure 3.4.4.3										
LINTELS SUPPORTING ROOF, FRAMES AND TIMBER FLOORS										
Lintels supporting roof and floors										
125x75x6UA	2.3	2.0	1.8	1.7	1.5	2.2	1.9	1.7	1.6	1.4
150x100x10UA	3.9	3.6	3.2	2.9	2.7	3.7	3.3	3.0	2.8	2.6
Note:										
1.	Top flange of lintel must be laterally restrained at the loading points.									
2.	Load must be evenly distributed along the member, eg joists.									
3.	Angle lintels—first dimension corresponds to vertical leg, eg 100x75x6UA, 100 mm leg is vertical.									
4.	For lintels supporting masonry walls, see Part 3.3.3.									

3.4.4.3 Columns

Columns may support the area provided for in [Table 3.4.4.1](#) provided—

- (a) the effective height of the column is determined in accordance with [Figure 3.4.4.4](#); and
- (b) the *floor area* to be supported is determined in accordance with [Figure 3.4.4.5](#); and
- (c) the load eccentricity between the centre of the column and the applied vertical loading complies with [Figure 3.4.4.6](#).

Figure 3.4.4.4	
DETERMINING EFFECTIVE COLUMN HEIGHT	
Note:	For the purposes of this Figure, to determine the column effective height, the actual column height (H) in Diagram a. must be multiplied by a column height factor (F1) in Table a.
Diagram a. Column height (H)	
Note:	H = Distance measured from the top of footing to underside of supported beam or bearer, or between intermediate lateral bracing points.

Figure 3.4.4.4		
DETERMINING EFFECTIVE COLUMN HEIGHT		
Note:	For the purposes of this Figure, to determine the column effective height, the actual column height (H) in Diagram a. must be multiplied by a column height factor (F1) in Table a.	
Diagram a. Column height (H)		
Note:	H = Distance measured from the top of footing to underside of supported beam or bearer, or between intermediate lateral bracing points.	
Table a. Column height factor (F1)		
BASE DETAIL	BRACING SYSTEM	
	Fully Braced ⁽¹⁾ Construction	Unbraced Construction (cantilever columns) ⁽²⁾
Cast into footing	1.00	2.60
Fixed by bolts to footing or slab	1.20	must not be used
Fixed by intermediate floor or bracing in both directions	1.20	2.60
Note:		
The flooring system must be fully braced to footing level by—		
(a)	a combination of column bracing sets, and timber or masonry bracing walls; or	
(b)	the provision of cantilever steel columns only (ie no column bracing sets, timber or masonry bracing walls).	

Figure 3.4.4.5

DETERMINING FLOOR AREA SUPPORTED

Note: The total area supported depends on the position of the column in the structure as shown in Diagram a. To calculate the correct area supported by a column, match the column's position with those shown in Diagram a. which shows a plan view of a floor and then calculate the total area supported from Table a.

Diagram a.	AREA SUPPORTED BY COLUMNS (Plan view)	Table a.	AREA SUPPORTED BY COLUMNS
	COLUMN	TOTAL AREA SUPPORTED	
	C1	$0.375L1 \times 0.375LA$	
	C2	$0.625(L1 + L2) \times 0.375LA$	
	C3	$0.375L1 \times 0.625(LA + LB)$	
	C4	$0.625(L1 + L2) \times 0.625(LA + LB)$	
	C5	$0.375L1 \times (L \text{ cant} + 0.5LC)$	
	C6	$0.625(L1 + L2) \times (L \text{ cant} + 0.5LC)$	

Figure 3.4.4.6

ACCEPTABLE LOAD ECCENTRICITY FOR COLUMNS

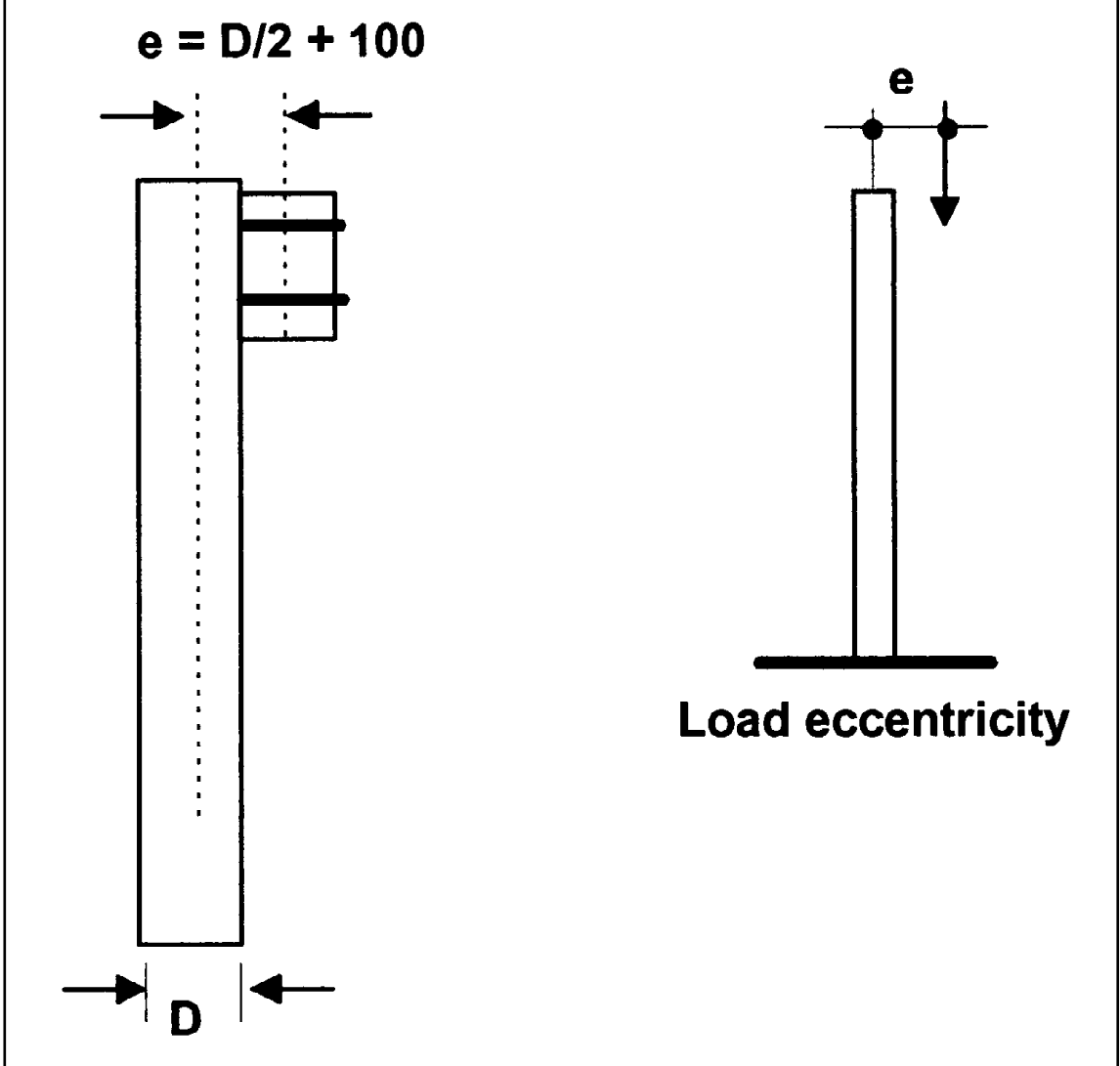

Table 3.4.4.1 COLUMNS—SUPPORTING TIMBER FLOOR ONLY

Note: Tabulated values are the columns sections to be used.						
COLUMN EFFECTIVE HEIGHT (mm)		FLOOR AREA SUPPORTED(m²)				
		5	10	15	20	25
CHS C250	600	60.3 x 3.6	88.9 x 4.0	101.6 x 5.0	114.3 x 5.4	139.7 x 5.0
	1200	60.3 x 4.5	88.9 x 4.0	101.6 x 5.0	114.3 x 5.4	139.7 x 5.0
	1800	60.3 x 4.5	88.9 x 4.0	101.6 x 5.0	114.3 x 5.4	139.7 x 5.0
	2400	60.3 x 4.5	88.9 x 4.0	101.6 x 5.0	114.3 x 5.4	139.7 x 5.0
	3600	76.1 x 3.6	101.6 x 4.0	114.3 x 4.5	139.7 x 5.0	139.7 x 5.0
CHS C350	600	60.3 x 2.9	88.9 x 2.6	101.6 x 3.2	114.3 x 3.6	139.7 x 3.5
	1200	60.3 x 2.9	88.9 x 2.6	101.6 x 3.2	114.3 x 3.6	139.7 x 3.5
	1800	60.3 x 2.9	101.6 x 2.6	114.3 x 3.2	114.3 x 3.6	139.7 x 3.5
	2400	76.1 x 2.3	101.6 x 2.6	114.3 x 3.2	139.7 x 3.0	139.7 x 3.5
	3600	88.9 x 2.6	101.6 x 2.6	114.3 x 3.2	139.7 x 3.0	165.1 x 3.0
SHS C350	600	50 x 50 x 2.5	75 x 75 x 2.5	75 x 75 x 4.0	100 x 100 x 4.0	100 x 100 x 4.0
	1200	65 x 65 x 2.0	75 x 75 x 2.5	75 x 75 x 4.0	100 x 100 x 4.0	100 x 100 x 4.0
	1800	65 x 65 x 2.0	75 x 75 x 3.0	100 x 100 x 3.0	100 x 100 x 4.0	100 x 100 x 4.0
	2400	65 x 65 x 2.0	75 x 75 x 3.0	100 x 100 x 3.0	100 x 100 x 4.0	100 x 100 x 5.0
	3600	65 x 65 x 2.5	75 x 75 x 4.0	100 x 100 x 3.0	100 x 100 x 4.0	100 x 100 x 5.0
SHS C450	600	50 x 50 x 2.0	65 x 65 x 2.5	75 x 75 x 3.0	100 x 100 x 2.8	100 x 100 x 3.3
	1200	50 x 50 x 2.0	65 x 65 x 2.5	75 x 75 x 3.0	100 x 100 x 3.0	100 x 100 x 3.3
	1800	50 x 50 x 2.3	75 x 75 x 2.3	75 x 75 x 3.3	100 x 100 x 3.0	100 x 100 x 3.8
	2400	65 x 65 x 2.0	75 x 75 x 2.5	75 x 75 x 3.5	100 x 100 x 3.0	100 x 100 x 3.8
	3600	65 x 65 x 2.3	100 x 100 x 2.0	100 x 100 x 2.8	100 x 100 x 3.8	100 x 100 x 4.0

Note: Tabulated values are the columns sections to be used.						
COLUMN EFFECTIVE HEIGHT (mm)		FLOOR AREA SUPPORTED(m²)				
		5	10	15	20	25
COLUMNS—SUPPORTING TILE ROOF ONLY						
COLUMN EFFECTIVE HEIGHT (mm)		ROOF AREA SUPPORTED (m²)				
		5	10	15	20	25
CHS C250	600	60.3 x 3.6	60.3 x 3.6	76.1 x 3.6	76.1 x 4.5	88.9 x 4.0
	1200	60.3 x 3.6	60.3 x 3.6	76.1 x 3.6	76.1 x 4.5	101.6 x 4.0
	1800	60.3 x 3.6	60.3 x 3.6	76.1 x 3.6	76.1 x 4.5	101.6 x 4.0
	2400	60.3 x 3.6	60.3 x 4.5	76.1 x 3.6	88.9 x 4.0	101.6 x 4.0
	3600	60.3 x 3.6	76.1 x 3.6	76.1 x 4.5	88.9 x 4.0	101.6 x 4.0
CHS C350	600	60.3 x 2.3	60.3 x 2.3	76.1 x 2.3	88.9 x 2.6	101.6 x 2.6
	1200	60.3 x 2.3	60.3 x 2.9	76.1 x 2.3	88.9 x 2.6	101.6 x 2.6
	1800	60.3 x 2.3	60.3 x 2.9	88.9 x 2.6	88.9 x 2.6	101.6 x 2.6
	2400	60.3 x 2.3	76.1 x 2.3	88.9 x 2.6	88.9 x 2.6	101.6 x 2.6
	3600	60.3 x 2.3	76.1 x 2.3	88.9 x 2.6	101 x 2.6	101.6 x 3.2
SHS C350	600	50 x 50 x 2.0	50 x 50 x 2.5	65 x 65 x 2.5	75 x 75 x 2.5	75 x 75 x 3.0
	1200	50 x 50 x 2.0	50 x 50 x 2.5	65 x 65 x 2.5	75 x 75x 2.5	75 x 75 x 3.0
	1800	50 x 50 x 2.0	65 x 65 x 2.0	65 x 65 x 2.5	75 x 75 x 2.5	75 x 75 x 3.0
	2400	50 x 50 x 2.0	65 x 65 x 2.0	65 x 65 x 2.5	75 x 75 x 2.5	75 x 75 x 4.0
	3600	50 x 50 x 2.5	65 x 65 x 2.5	75 x 75 x 2.5	75 x 75 x 3.0	75 x 75 x 4.0
SHS C450	600	50 x 50 x 1.6	50 x 50 x 2.0	65 x 65 x 2.0	65 x 65 x 2.3	65 x 65 x 2.8
	1200	50 x 50 x 1.6	50 x 50 x 2.0	65 x 65 x 2.0	65 x 65 x 2.3	65 x 65 x 2.8
	1800	50 x 50 x 1.6	65 x 65 x 1.6	65 x 65 x 2.0	65 x 65 x 2.5	75 x 75 x 2.5
	2400	50 x 50 x 1.6	50 x 50 x 2.5	65 x 65 x 2.3	75 x 75 x 2.3	75 x 75 x 2.8
	3600	50 x 50 x 2.0	65 x 65 x 2.0	75 x 75 x 2.3	100 x 100 x 2.0	100 x 100 x 2.3

3.4.4.4 Corrosion protection

Structural steel members must be protected against corrosion in accordance with [Table 3.4.4.2](#).

Explanatory information:

1. For internal steelwork, where the steel is situated in a basically permanently dry location, the steel normally needs little or no protection.
2. Beams over kitchens and bathrooms and the like, where moisture may be present, may need increased protection.
3. For applications outside the scope of this table, seek specialist advice.

Table 3.4.4.2 PROTECTIVE COATINGS FOR STEELWORK

ENVIRONMENT	LOCATION	MINIMUM PROTECTIVE COATING		
		General structural steel members	Lintels in masonry	
MODERATE	INTERNAL	No protection required		
More than 1 km from breaking surf or more than 100 m from salt water not subject to breaking surf or non-heavy industrial areas	EXTERNAL	Option 1.	2 coats alkyd primer; or	
		Option 2.	2 coats alkyd gloss	
		Option 3.	Hot dip galvanise 300 g/ m ² min	
		Option 4.	Hot dip galvanise 100 g/m ² min plus—	
			(a) 1 coat solvent based vinyl primer; or	
			(b) 1 coat vinyl gloss or alkyd.	
SEVERE	INTERNAL	Option 1.	2 coats alkyd primer	
		Option 2.	2 coats alkyd gloss	
Within 1 km from breaking surf or within 100 m of salt water not subject to breaking surf or heavy industrial areas	EXTERNAL	Option 1.	Inorganic zinc primer plus 2 coats vinyl gloss finishing coats	Hot dip galvanise 600g/m ²
		Option 2.	Hot dip galvanise 300g/m ²	
		Option 3.	Hot dip galvanise 100 g/m ² min plus—	
			(a) 2 coats solvent based vinyl primer; or	
			(b) 2 coats vinyl gloss or alkyd.	

Notes:

1. Heavy industrial areas means industrial environments around major industrial complexes. There are only a few such regions in Australia, examples of which occur around Port Pirie and Newcastle.

ENVIRONMENT	LOCATION	MINIMUM PROTECTIVE COATING	
		General structural steel members	Lintels in masonry
2.	The outer leaf and cavity of an external masonry wall of a building, including walls under open carports are considered to be external environments. A part of an internal leaf of an external masonry wall which is located in the roof space is considered to be in an internal environment.		
3.	Where a paint finish is applied the surface of the steel work must be hand or power tool cleaned to remove any rust immediately prior to painting.		
4.	All zinc coatings (including inorganic zinc) require a barrier coat to stop conventional domestic enamels from peeling.		
5.	Refer to the paint manufacturer where decorative finishes are required on top of the minimum coating specified in the table for protection of the steel against corrosion.		

PART **3.5**

ROOF AND WALL CLADDING

- 3.5.1 Roof Cladding
- 3.5.2 Gutters and Downpipes
- 3.5.3 Wall Cladding

PART 3.5 CONTENTS

PART 3.5 ROOF AND WALL CLADDING

Explanatory Information

3.5.1 Roof cladding

- 3.5.1.0 Acceptable construction manuals
- 3.5.1.1 Application
- 3.5.1.2 Roof tiling
- 3.5.1.3 Metal sheet roofing

3.5.2 Gutters and downpipes

- 3.5.2.0 Acceptable construction manual
- 3.5.2.1 Application
- 3.5.2.2 Materials
- 3.5.2.3 Selection of guttering
- 3.5.2.4 Installation of gutters
- 3.5.2.5 Downpipes—size and installation

3.5.3 Wall Cladding

- 3.5.3.1 Application
- 3.5.3.2 Timber weatherboard cladding
- 3.5.3.3 Fibre cement planks and weatherboard cladding
- 3.5.3.4 Sheet wall cladding
- 3.5.3.5 Eaves and soffit linings
- 3.5.3.6 Flashings to wall openings

PART 3.5

EXPLANATORY INFORMATION

Explanatory information:

Explanatory information:

These provisions relate to installing systems to waterproof roofs, walls and wall openings.

It should be noted that other construction methods may be used to achieve the same results as specified in this Part provided they comply with the appropriate *Performance Requirement*.

PART 3.5.1 ROOF CLADDING

Appropriate Performance Requirements

Where an alternative roof cladding is proposed as an *Alternative Solution* to that described in Part 3.5.1, that proposal must comply with—

- (a) Performance Requirement **P2.1**; and
- (b) Performance Requirement **P2.2.2**; and
- (c) the relevant *Performance Requirements* determined in accordance with **1.0.10**.

A. Acceptable construction manuals

3.5.1.0

Performance Requirements **P2.1** and **P2.2.2** are satisfied for roof cladding on Class 1 and 10 buildings if it complies with one of the following manuals:

- (a) AS 2049—Roof tiles.
- (b) AS 2050—Installation of roof tiles.
- (c) AS 1562.1—Design and installation of sheet roof and wall cladding—Metal.
- (d) AS/NZS 4256 Pts 1, 2, 3 and 5; and AS/NZS 1562.3—Plastic sheet roofing.
- (e) AS/NZS 1562.2—Design and installation of sheet roof and wall cladding—Corrugated fibre reinforced cement.
- (f) ASTM D3018-90—Asphalt shingles.
- (g) AS/NZ 4200—Installation of pliable membrane and underlay.

B. Acceptable construction practice

3.5.1.1 Application

Compliance with this Part satisfies *Performance Requirements* **P2.1** and **P2.2.2** for roof cladding, provided—

- (a) the building is located in an area with a *design wind speed* of not more than W41; and

Explanatory information:

1. Information on *design wind speeds* for particular areas may be available from the *appropriate authority*.
2. A map indicating cyclonic regions of Australia is contained in **Part 3.10.1**.

- (b) roof tiles are installed in accordance with 3.5.1.2; and
- (c) sheet roofing is installed in accordance with 3.5.1.3.

3.5.1.2 Roof tiling

- (a) Roof tiles, complying with AS 2049, must be installed, fixed and flashed in accordance with the relevant provisions of this Part.
- (b) Roof tiles on roofs with a pitch not more than 35 degrees must be fixed in accordance with Figure 3.5.1.1.
- (c) Fixings for roof battens and batten sizes must comply with Part 3.4.3.
- (d) All tiled roof flashings, ridge and hip tiles must be installed in accordance with Figure 3.5.1.2.
- (e) Lead flashings must not be used on any roof that is part of a potable water catchment area.

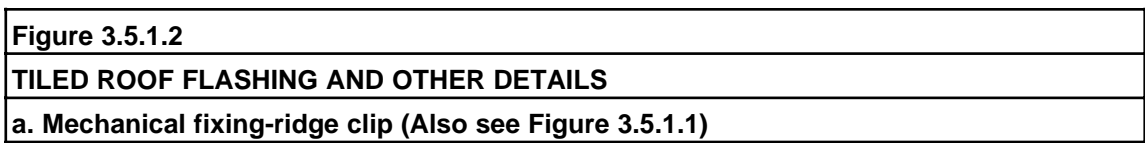
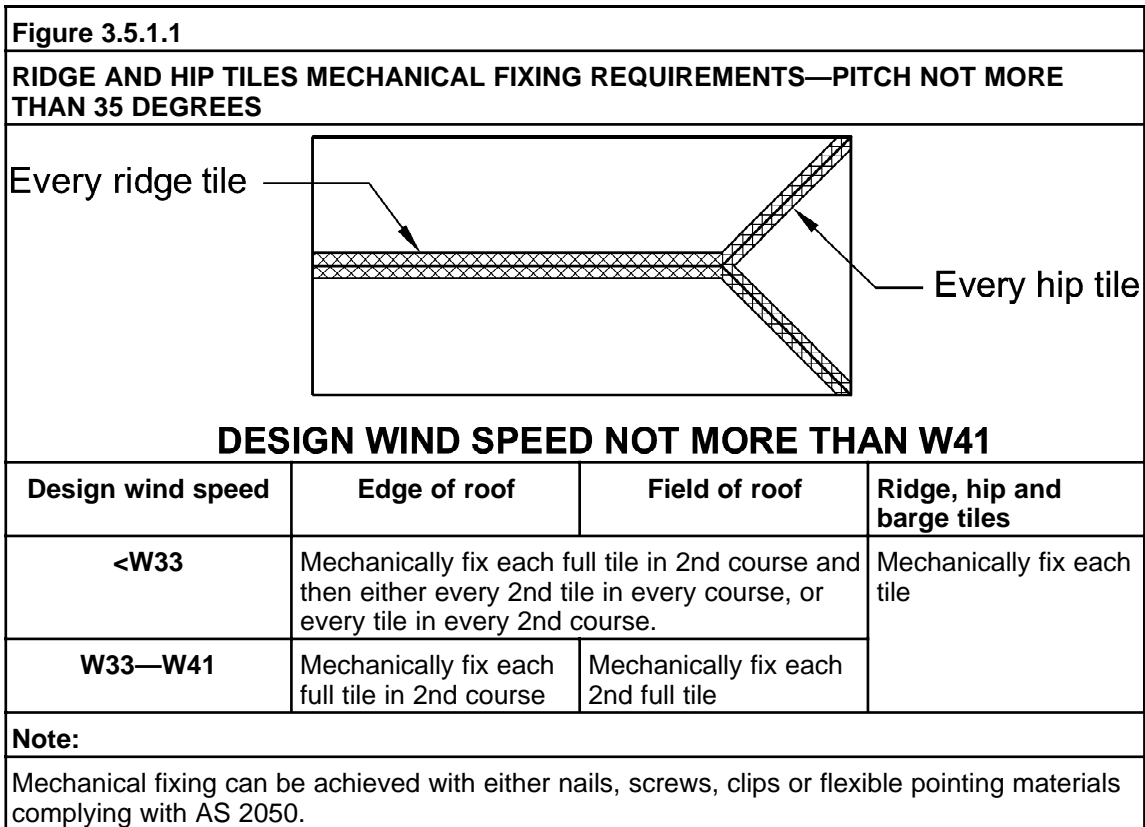

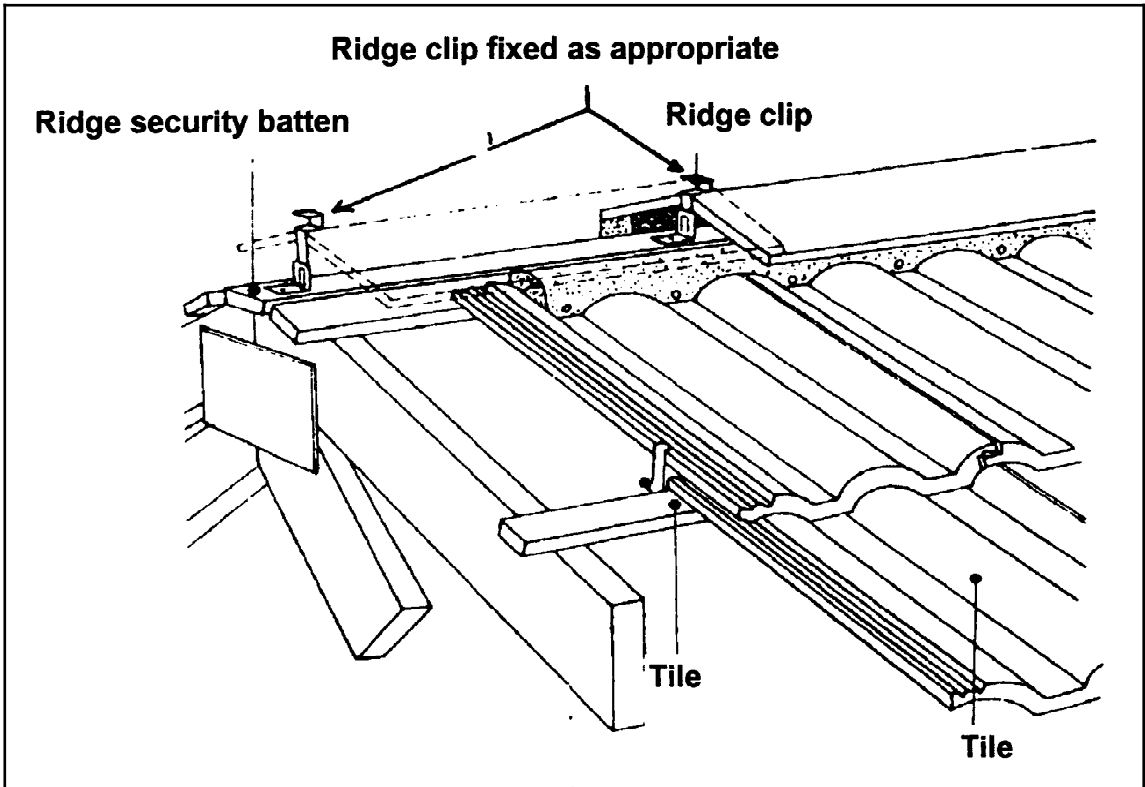

b. Dry valley

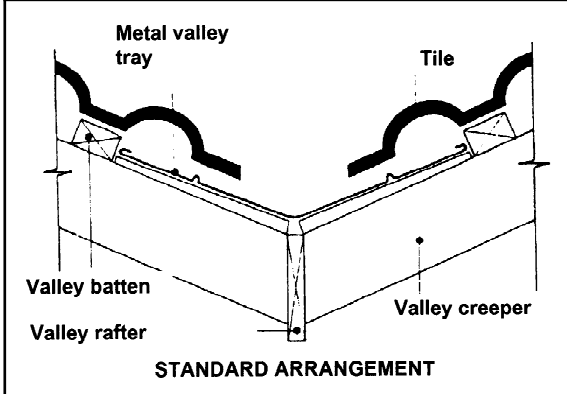

c. Bedded and pointed valley

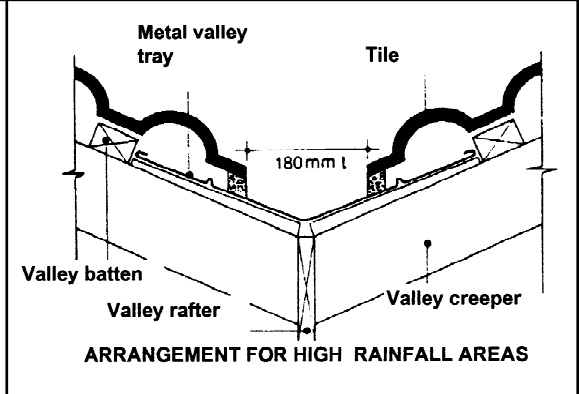

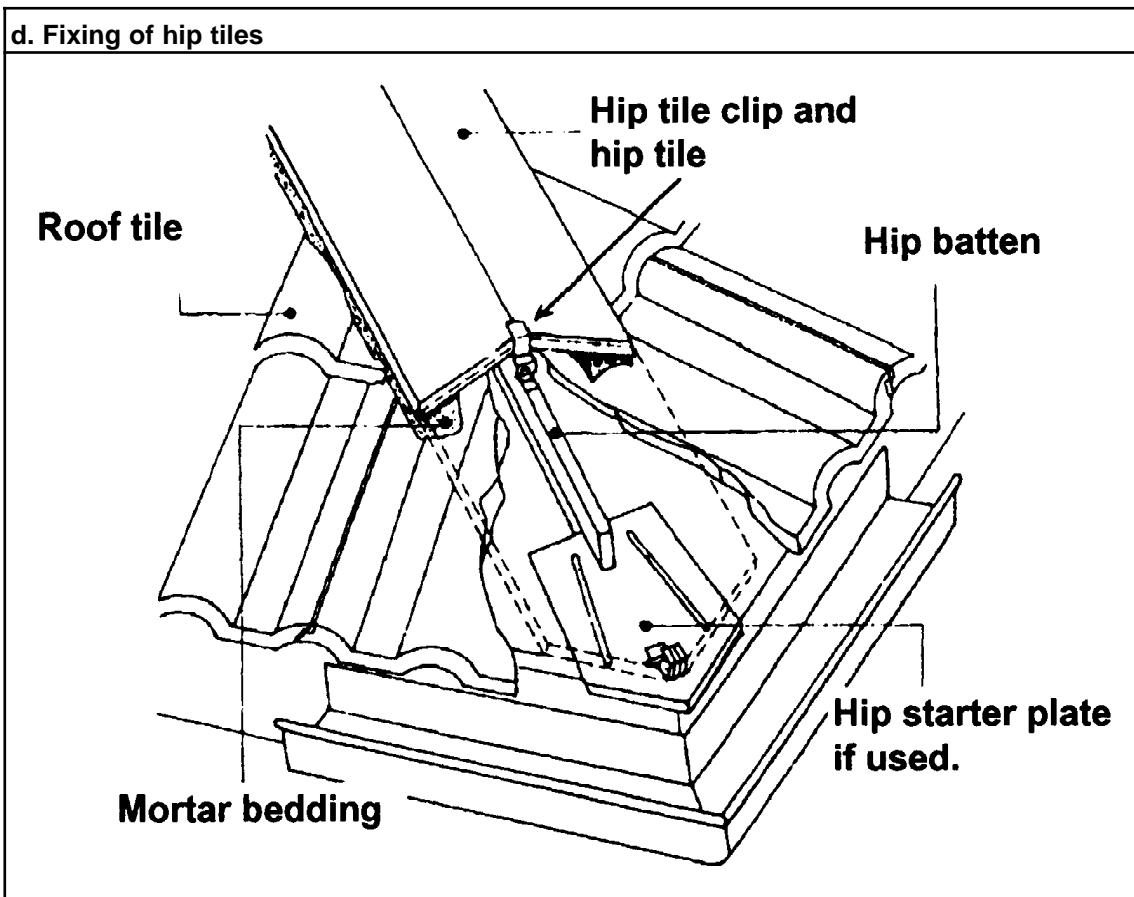

3.5.1.3 Metal sheet roofing

- (a) The design and installation of metal sheet roofing must comply with the relevant provisions of this Part.
- (b) Metal sheet roofing must be protected from corrosion in accordance with [Table 3.5.1.1](#).

Table 3.5.1.1 ACCEPTABLE CORROSION PROTECTION FOR SHEET ROOFING

ROOF ENVIRONMENT	METAL COATING IN ACCORDANCE WITH AS 1397	
	Metallic coated steel	Metallic and organic coating
Moderate	(a) Z450 galvanised	(a) Z275 galvanised
Inland areas with no salt or heavy industry pollution	(b) AZ150 zinc/aluminium	(b) AZ150 zinc/aluminium
Severe		
Close to the sea with frequent onshore winds and in local areas with heavy industrial pollution	AZ200	Not suitable

- (c) Where different metals are used in a roofing system, including cladding, *flashings*, fasteners, downpipes etc, they must be compatible with each other (to prevent corrosion due to an adverse chemical reaction) as described in [Table 3.5.1.2](#) and—
- (i) no lead materials can be used upstream from zinc-aluminium coated materials; and
 - (ii) no copper materials can be used upstream from galvanised coated materials.
- (d) Metal sheet roofing must—
- (i) be fixed at spacings in accordance with [Figure 3.5.1.5](#); and
 - (ii) use fastening devices made of a compatible metal to the roofing in accordance with [3.5.1.3\(c\)](#); and
 - (iii) when using both clipped and pierced fastening systems—
 - (A) employ an anti-capillary feature in the side lap of the sheet, to prevent capillary action drawing moisture into the lap and allowing the lap to drain (achieved by not over tightening the sheet fixings, see [Figure 3.5.1.3](#)); and
 - (B) wherever possible have the sheets laid so that the side lap is facing away from prevailing weather.

Table 3.5.1.2 ACCEPTABILITY OF CONTACT BETWEEN DIFFERENT ROOFING MATERIALS

Note:								
1. No—means the metal cannot be used in association with the other metal.								
2. Yes—means the metal can be used in association with the other metal.								
CLADDING MATERIAL	ACCESSORY OR FASTENER MATERIAL							
	Stainless steel		Zinc-coated steel and Zinc		Zinc/Aluminium coated steel		Lead	
	Atmosphere Classification (S = Severe and M = Moderate environment as Per Table 3.5.1.1)							
	S	M	S	M	S	M	S	M
Copper and copper alloys	No	Yes	No	No	No	No	No	Yes
Stainless steel (300 series)	Yes	Yes	No	No	No	No	No	Yes
Zinc-coated steel and zinc	No	Yes	Yes	Yes	Yes	Yes	No	Yes
Zinc/aluminium coated steel	No	Yes	Yes	Yes	Yes	Yes	No	No
Lead	Yes	Yes	No	Yes	No	No	Yes	Yes

Figure 3.5.1.3

SIDE LAPPING FASTENING DETAIL

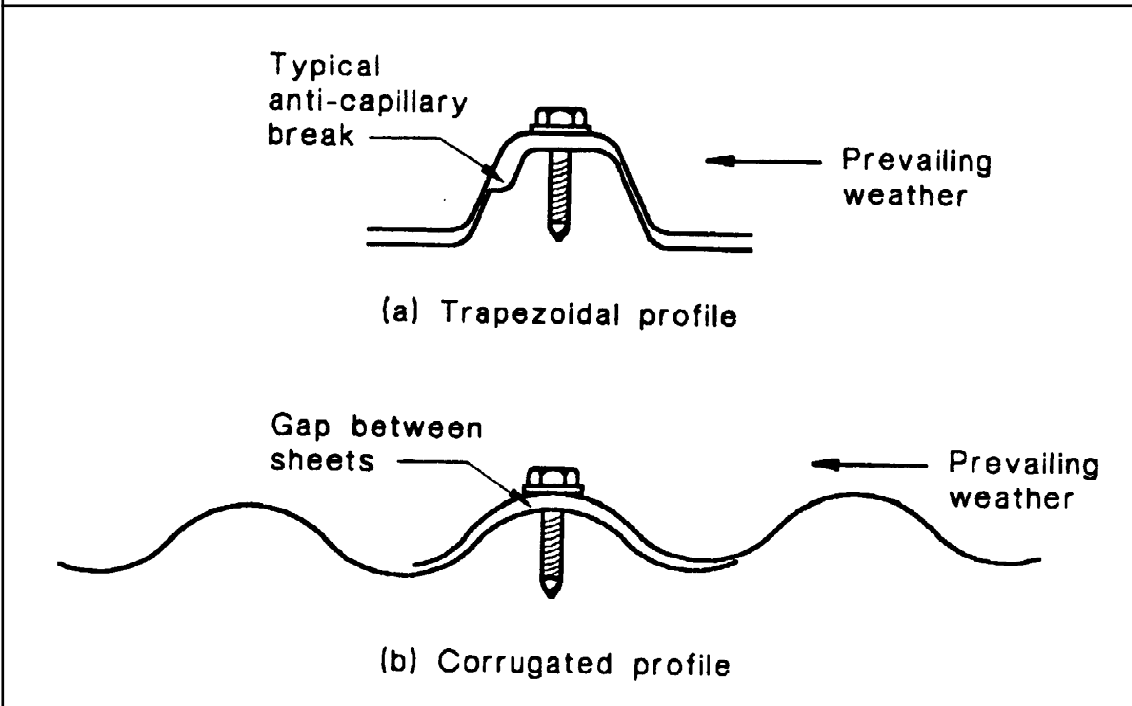

- (e) Sheets must be—
- (i) laid wherever possible using complete lengths from ridge to eaves; or
 - (ii) where a complete length cannot be laid—
 - (A) each run should be laid in specific sequence (see [Figure 3.5.1.4](#)) from bottom to top before moving on to the next run; and
 - (B) the distance for end lapping where sheets meet is—
 - (aa) for roof slopes between 5–15 degrees (1:12–1:4)—a lap of 200 mm; and
 - (bb) for roof slopes above 15 degrees (1:4)—a lap of 150 mm; and
 - (iii) stop ended (ie each valley turned up 60 degrees) at the ridge line of each length.

Figure 3.5.1.4
SHEET LAYING SEQUENCE

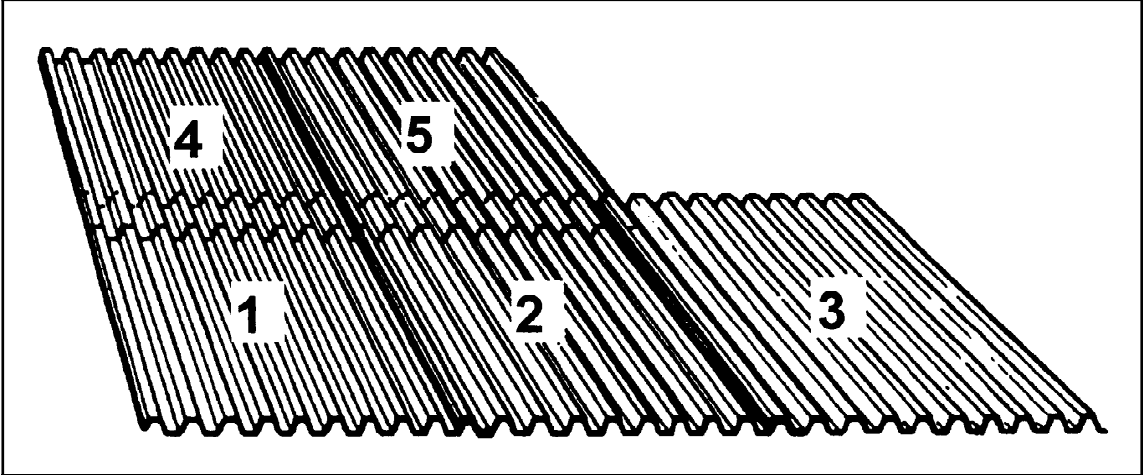

(f) Metal sheet roofing must comply with the pitch and span limitations between roofing supports as shown in [Figure 3.5.1.5](#).

Figure 3.5.1.5
MAXIMUM SPAN AND FIXING FOR METAL SHEET ROOFING

Note: The end span of some trapezoidal roofing systems may need to be reduced to 1.5 m (see proprietary information).

Diagram a. Typical profiles—Pitch is appropriate for a sheet run up to 25 m in length

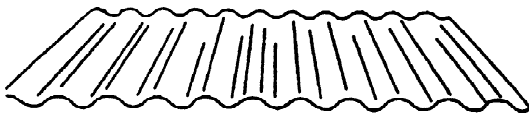

Corrugated
 Minimum pitch - 5 degrees



Close Pitched Trapezoidal
 Minimum pitch - 3 degrees



Trapezoidal
 Minimum pitch - 3 degrees



Concealed Fastened
 Minimum pitch - 1 degree

Figure 3.5.1.5

MAXIMUM SPAN AND FIXING FOR METAL SHEET ROOFING

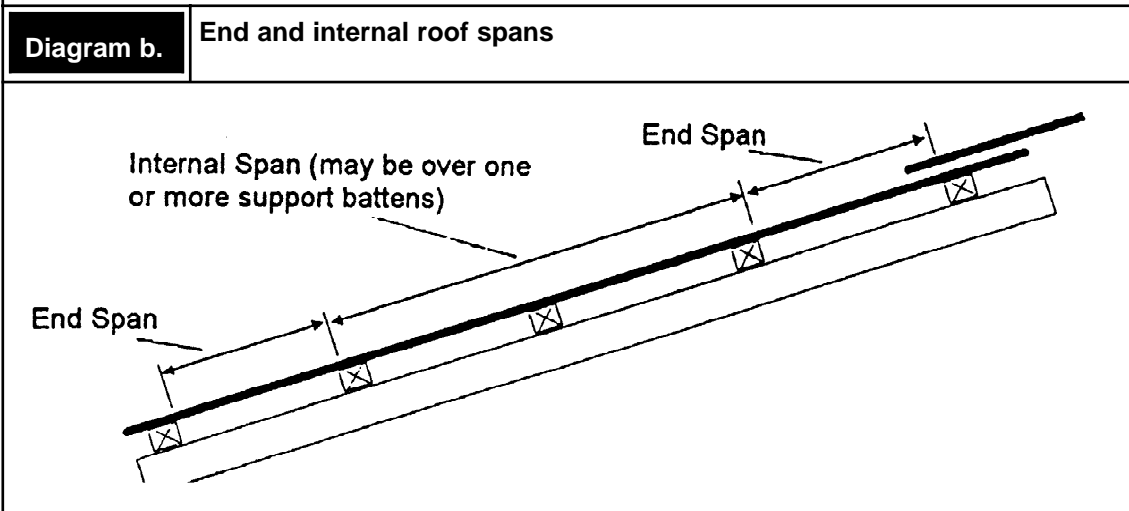

Note: End span is also the end of sheets where they overlap with an adjoining sheet.

PROFILE	BASE METAL THICKNESS (mm)	END SPAN (mm)	INTERNAL SPAN (mm)	FIXING (crest fastening)	
				END SPAN	INTERNAL SPANS
Corrugated	0.42	950	1200	Every second rib	Every third rib
Close pitched trapezoidal	0.42	1900*	2400	Every rib	Every second rib
Trapezoidal	0.42	1350	1700	Every rib	
Concealed Fasteners	0.48	1800	2100	Every rib	

- (g) Sheet metal roof *flashings* and cappings must comply with the following:
- (i) Roof *flashings* and cappings must be purpose made, machine-folded sheet metal sections of materials compatible with all up and downstream metal roof covering materials in accordance with [3.5.1.3\(c\)](#).
 - (ii) The type of fasteners for *flashings* and cappings must comply with [3.5.1.3\(d\)](#).
 - (iii) The frequency of fastener fixings for transverse *flashings* and cappings must comply with [Table 3.5.1.3](#).

Table 3.5.1.3 FASTENER FREQUENCY FOR TRANSVERSE FLASHINGS AND CAPPINGS

ROOF TYPE	FIXING FREQUENCY	FASTENER TYPE
Concealed fastened roofs	Every rib	Rivets and self drilling screws
Pierced fastened roofs	Every 2nd rib	Self drilling screws or rivets

ROOF TYPE	FIXING FREQUENCY	FASTENER TYPE
Corrugated roofs	Every 4th rib	Self drilling screws or rivets

- (iv) Joints in *flashing* and cappings must be not less than 25 mm, fastened at intervals not more than 40 mm and lapped in the direction of the fall of the roof.
- (v) Wall and step *flashings* must be fastened into masonry walls with galvanised or zinc/aluminium sheet metal wedges at each end of each length and at intermittent intervals of not more than 500 mm and must overlap by not less than 75 mm in the direction of flow.
- (vi) Lead *flashings* must not be used with prepainted steel or zinc/aluminium steel or on any roof if the roof is part of a potable (drinking) water catchment area.
- (vii) Anti capillary breaks must be installed in accordance with **Figure 3.5.1.6** and be—
 - (A) for flat surfaces—10 mm/30 degree fold; and
 - (B) all other surfaces—10 mm/90 degree or 135 degree fold.

Figure 3.5.1.6

ANTI CAPILLARY BREAKS

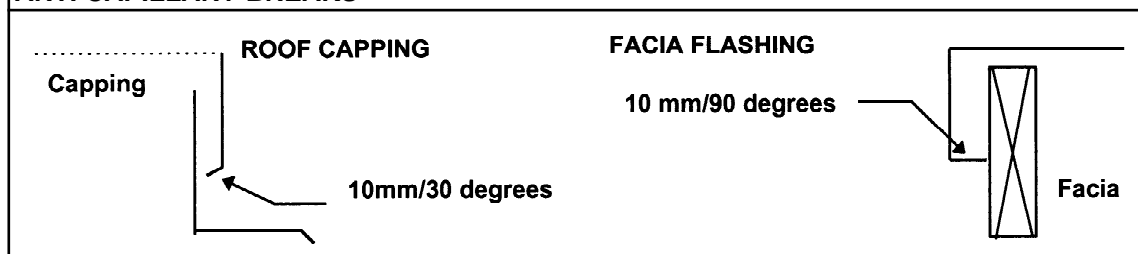

- (viii) Acceptable *flashing* configurations are shown in **Figure 3.5.1.7**.

Figure 3.5.1.7

ACCEPTABLE FLASHING DETAILS

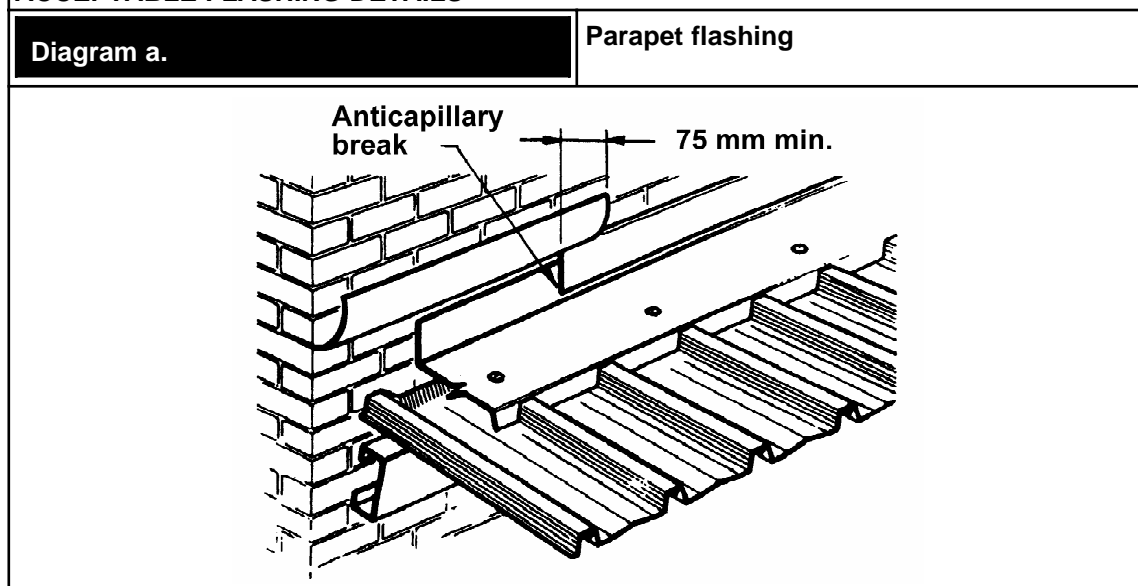
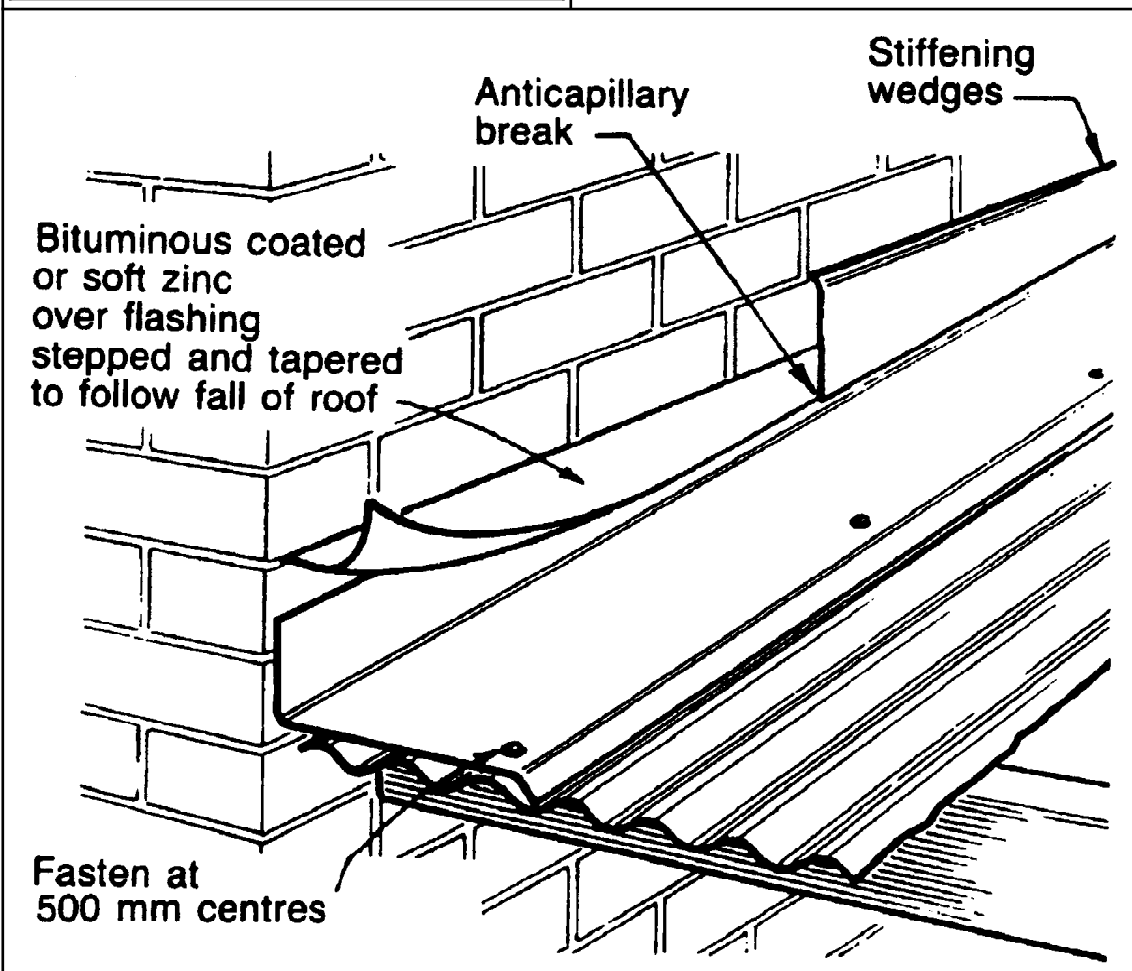

Figure 3.5.1.7

ACCEPTABLE FLASHING DETAILS

Diagram b.

Parapet and end wall flashing



- (h) *Flashing* of penetrations must comply with the following:
- (i) Collar *flashings* must permit the total drainage of the area above the penetration.
 - (ii) On the completion of installation, the roof structure must be restored to its original strength by installing roof trimmers and soaker supports as necessary.
 - (iii) The type of fasteners for *flashings* and cappings must comply with [3.5.1.3\(d\)](#).
 - (iv) Lead *flashings* must not be used with prepainted steel or zinc/aluminium steel or on any roof if the roof is part of a potable water catchment area.
 - (v) Acceptable *flashings* for penetrations are shown in [Figure 3.5.1.8](#).
 - (vi) Clearance for heating appliance roof support members must be in accordance with [Part 3.7.3](#).

Figure 3.5.1.8

TYPICAL ROOF PENETRATION FLASHING DETAILS

a. PVC aprons

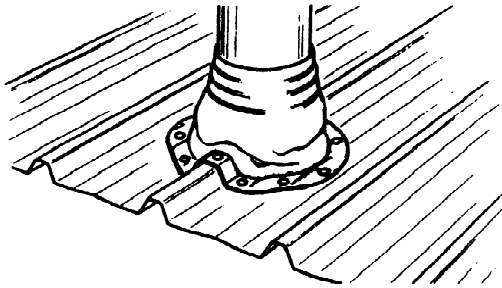

b. Collar flashings

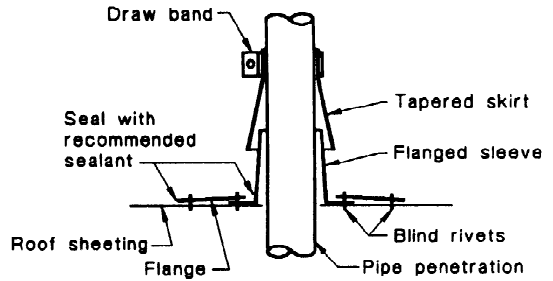

c. Large penetrations—using apron

Tray sealed and fastened to roof sheeting

Apron flashing turned down between ribs

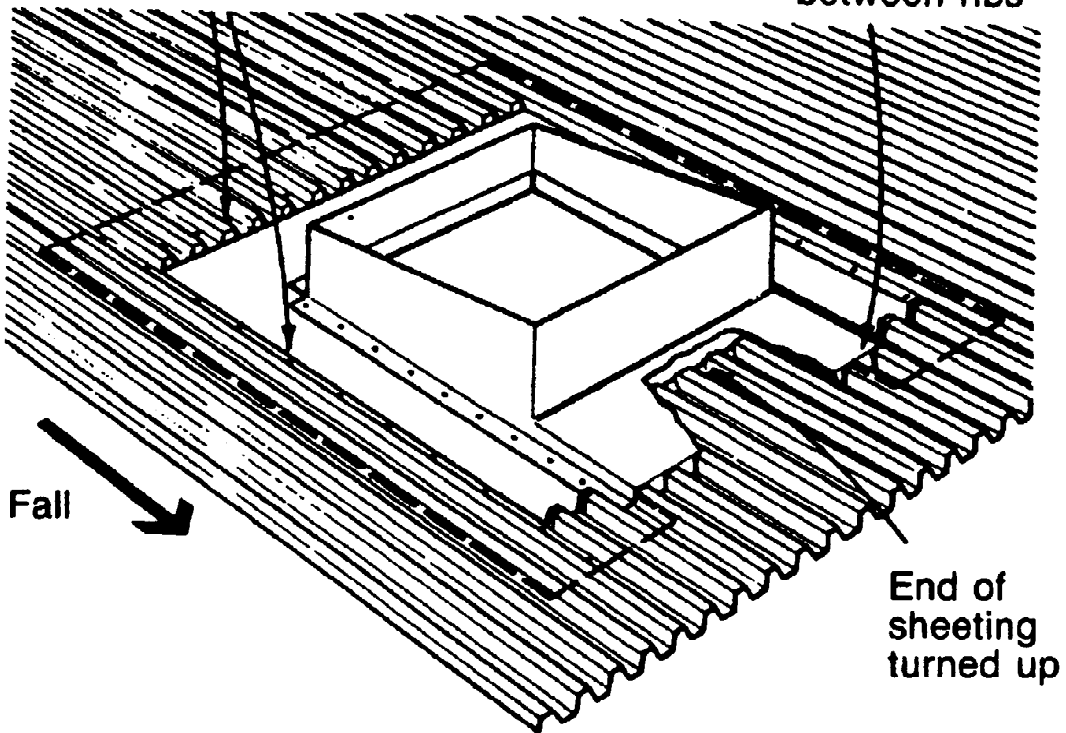

PART 3.5.2 GUTTERS AND DOWNPIPES

Appropriate Performance Requirements:

Where an alternative gutter and downpipe system is proposed as an *Alternative Solution* to that described in Part 3.5.2, that proposal must comply with—

- (a) Performance Requirement **P2.2.1**; and
- (b) the relevant Performance Requirements determined in accordance with **1.0.10**.

A. Acceptable construction manuals

3.5.2.0

Performance Requirement **P2.2.1** is satisfied for gutters and downpipes if they are designed and constructed in accordance with AS/NZS 3500.3.2—Stormwater drainage, or AS/NZS 3500.5—Domestic installations, Section 5—Stormwater drainage.

B. Acceptable construction practice

3.5.2.1 Application

Compliance with this Part satisfies Performance Requirement **P2.2.1** for gutters and downpipes provided—

- (a) the roof drainage system is connected to a stormwater drainage system that complies with **Part 3.1.2**; and
- (b) the roof drainage system is designed so that any overflow during heavy rain periods is prevented from flowing back into the building.

Explanatory information:

1. The requirement to install drainage systems from roofs and sub-soil drains should be confirmed with the *appropriate authority*. These provisions need only be applied when drainage systems are necessary.
2. Information on drainage requirements outside the allotment can be obtained from the *appropriate authority*.

3.5.2.2 Materials

Gutters, downpipes and *flashings* must—

- (a) be manufactured in accordance with AS/NZS 2179.1 for metal; and

- (b) be manufactured in accordance with AS 1273 for UPVC components; and
- (c) be compatible with all upstream roofing materials in accordance with **3.5.1.3(c)**; and
- (d) not contain any lead if used on a roof forming part of a potable water catchment area.

3.5.2.3 Selection of guttering

The size of guttering must—

- (a) be in accordance with **Table 3.5.2.2**; and
- (b) be suitable to remove rainwater falling at the appropriate rainfall intensity listed in **Table 3.5.2.1** as follows—
 - (i) for eaves gutters—20 year *average recurrence interval*; or
 - (ii) for internal box and valley gutters—100 year *average recurrence interval*.

3.5.2.4 Installation of gutters

- (a) Gutters must be installed with a fall of not less than—
 - (i) 1:500 for eaves gutters, unless fixed to metal facias; and
 - (ii) 1:100 for box gutters.
- (b) Eaves gutters must be supported by brackets securely fixed at stop ends and at not more than 1.2 m centres.
- (c) Valley gutters on a roof with a pitch—
 - (i) more than 12.5 degrees—must have width of not less than 400 mm and be wide enough to allow the roof covering to overhang not less than 150 mm each side of the gutter; or
 - (ii) not more than 12.5 degrees—must be designed as a box gutter.

3.5.2.5 Downpipes—size and installation

- (a) Downpipes must be securely fixed to walls.
- (b) The spacing between downpipes must not be more than 12 m.
- (c) Downpipes must be fixed as close as possible to valley gutters and, if the downpipe is more than 1.2 m from a valley, provision for overflow must be made.
- (d) Where high-fronted gutters are installed, provision must be made to avoid any overflow from flowing back into the roof or building structure by installing slotted gutters or the like.
- (e) Downpipes must—
 - (i) be compatible with other roofing materials used in the roofing system in accordance with **3.5.1.3(c)**; and
 - (ii) be selected in accordance with appropriate eaves gutter section as shown in **Table 3.5.2.2**.

Table 3.5.2.1 RAINFALL INTENSITIES

Locality	5 minute rainfall intensity (mm/h)		Locality	5 minute rainfall intensity (mm/h)	
	Average recurrence interval, once in—			Average recurrence interval, once in—	
	20 years	100 years		20 years	100 years
ACT			SA		
Canberra	137	194	Adelaide	123	186
			Mt Gambier	108	168
NSW			Murray Bridge	117	181
Albury	135	191	Port Augusta	124	189
Broken Hill	130	181	Port Pirie	125	201
Goulburn	145	197	Yorktown	118	197
Kiama	224	283			
Newcastle	181	233	WA		
Orange	152	214	Albany	142	217
Sydney	214	273	Broome	252	343
Tweed Heads	245	303	Bunbury	148	215
Wollongong	233	294	Derby	254	343
			Geraldton	132	173
VIC			Kalgoorlie	116	180
Ballarat	127	184	Perth	146	214
Benalla	133	187	Port Hedland	233	332
Geelong	118	172	Tom Price	164	222
Horsham	120	174			
Lakes Entrance	124	179	TAS		
Melbourne	127	186	Burnie	118	191
Mildura	125	174	Flinders Island	128	184
Stawell	127	185	Hobart	99	155
			Launceston	101	150
QLD			Queenstown	118	183
Brisbane	251	333	St. Marys	205	266
Bundaberg	241	318			
Cairns	282	368	NT		
Cape York	301	388	Alice Springs	139	204
Cloncurry	172	228	Darwin	285	366

Locality	5 minute rainfall intensity (mm/h)		Locality	5 minute rainfall intensity (mm/h)	
	Average recurrence interval, once in—			Average recurrence interval, once in—	
	20 years	100 years		20 years	100 years
Innisfail	254	323	Katherine	230	304
Mackay	273	363			
Mt Isa	169	223			
Noosa	253	320			
Rockhampton	248	336			
Toowoomba	189	251			
Townsville	260	346			
Weipa	293	370			

Table 3.5.2.2 GUTTER AND DOWNPIPE SELECTION

Table a. Gutter sizes for various rainfall intensities and roof catchment areas per downpipe					
Design Rainfall Intensity (mm/h) (as per Table 3.5.2.1)	Roof Catchment Area per Downpipe—m ²				
	30	40	50	60	70
	Size of Gutter Required to Drain Roof Catchment Area into One (1) Downpipe (A, B, C, D, E and F defined in Table b.)				
90	A or C	A or C	A or C	A or C	A or C
120	A or C	A or C	A or C	A or C	A or D
140	A or C	A or C	A or C	A or D	B or E
160	A or C	A or C	A or C	A or E	B or E
175	A or C	A or C	A or D	B or E	E
200	A or C	A or C	A or D	B or E	F
225	A or C	A or C	A or B	E	F
255	A or C	A or D	B or E	E	F
275	A or C	A or D	B or E	F	F
325	A or C	B or E	F	F	F
425	A or C	E	F	F	F

Table b. Gutter sizes for various rainfall intensities		
Gutter Type (as per Table a.)	Gutter description	Minimum Cross Sectional Area mm ²
A	Medium Rectangular Gutter	6500
B	Large Rectangular Gutter	7900

Table b. Gutter sizes for various rainfall intensities		
Gutter Type (as per Table a.)	Gutter description	Minimum Cross Sectional Area mm ²
C	115 mm D Gutter	5200
D	125 mm D Gutter	6300
E	150 mm D Gutter	9000
F	Gutter must be designed in accordance with AS/NZS 3500.3.2 or Section 5 of AS/NZS 3500.5	

Table c. Downpipe selection					
Down pipe Section	Gutter Sections—(as per Table b.)				
	A	B	C	D	E
75 mm dia.	Yes	Yes	Yes	Yes	No
100 mm × 50 mm	Yes	Yes	Yes	Yes	Yes
90 mm dia.	Yes	Yes	Yes	Yes	Yes
100 mm × 75 mm	Yes	Yes	Yes	Yes	Yes
Legend:	Yes—downpipe is suitable for the eaves gutter selection; and				
	No—downpipe is not suitable for the eaves gutter selection.				

Explanatory information:

Stormwater drainage systems specified in the *Housing Provisions* are not designed to remove all of the water during exceptionally heavy rain, especially in tropical areas. Accordingly, it is necessary to design and install the system so that when overflowing occurs any water is directed away in a manner which ensures it does not pond against, or enter into, the building.

This may be achieved by using slotted gutters, oversized gutters and downpipes, locating the gutter so that it is below the top edge of the fascia or the installation of rainwater heads with overflow slots.

The installation of downpipes, especially near valley gutters, are designed to ensure rainwater from areas on the roof that have concentrated water flows perform adequately. If downpipe spacings are to be increased, allowance for overflow should be considered.

Consideration needs to be given to box gutters, valley gutters etc located above the internal areas of a building. In these situations if adequate overflow controls cannot be implemented there may be a need to increase the size and capacity of drainage components to remove all water anticipated during heavy rain periods.

There are many options available to designers using the requirements of the *Housing Provisions*. The designer will need to choose an overflow system that will cope with the expected rain intensity, ie in heavy downpours a slotted gutter may be inadequate.

PART 3.5.3 WALL CLADDING

Appropriate Performance Requirements

Where an alternative wall cladding is proposed as an *Alternative Solution* to that described in Part 3.5.3, that proposal must comply with—

- (a) *Performance Requirement P2.1*; and
- (b) *Performance Requirement P2.2.2*; and
- (c) the relevant *Performance Requirements* determined in accordance with **1.0.10**.

Acceptable construction practice

3.5.3.1 Application

Compliance with this Part satisfies *Performance Requirements P2.1* and **P2.2.2** for wall cladding provided—

- (a) the building is located in an area with a *design wind speed* of not more than W41; and

Explanatory information:

1. Information on *design wind speeds* for particular areas may be available from the *appropriate authority*.
2. A map indicating cyclonic regions of Australia is contained in **Part 3.10.1**.
3. For wall cladding in areas with a *design wind speed* of more than W41 refer to the appropriate design manual listed in **Part 3.11**.

- (b) wall cladding is installed in accordance with—
 - (i) **3.5.3.2** for timber weatherboard cladding; and
 - (ii) **3.5.3.3** for fibre cement planks and weatherboard cladding; and
 - (iii) **3.5.3.4** for fibre cement sheet and plywood sheet cladding; and
- (c) fibre cement sheet eaves are installed in accordance with **3.5.3.5**; and
- (d) openings in cladding are flashed in accordance with **3.5.3.6**.

3.5.3.2 Timber weatherboard cladding

Timber cladding must be installed as follows:

- (a) Splayed timber weatherboards must be fixed in accordance with **Figure 3.5.3.1** and with a lap not less than—
 - (i) 30 mm for hardwood, cypress and treated pine; and
 - (ii) 20 mm for western red cedar; and

- (iii) 25 mm for baltic pine.
- (b) Profiled timber boards must be—
 - (i) fixed with the overlap and groove closely fitted; and
 - (ii) with tongue and groove profile, fixed tongue edge up.
- (c) Spacing of fixings must be—
 - (i) one nail per board at each stud at not more than 650 mm centres measured along the board; and
 - (ii) nailed so that they do not penetrate the tip or thinner edge of the board beneath, ie for 30 mm lap, nail 35 mm from the butt (see [Figure 3.5.3.1](#)).
- (d) Nails used to fix timber cladding must comply with the following:
 - (i) Where nails are punched and filled prior to painting, with standard steel bullet-head nails.
 - (ii) Uncoated copper or steel nails must not be used for western red cedar (silicon bronze, monel metal, stainless steel or hot-dipped galvanised are suitable).
 - (iii) In all other cases, nails must be hot-dipped galvanised flat head or bullet head.
- (e) Acceptable nail sizes are—
 - (i) for hardwood and cypress frames—50×2.8 mm plain shank; and
 - (ii) for softwood frames—50×3.15 mm annular threaded.

3.5.3.3 Fibre cement planks and weatherboard cladding

Fibre cement plank and weatherboard cladding must be installed as follows:

- (a) 7.5 mm (minimum) fibre cement planks and weatherboards must be—
 - (i) manufactured in accordance with AS/NZS 2908.2 or ISO 8336; and
 - (ii) fixed with a lap of not less than 25 mm (see [Figure 3.5.3.1](#)).
- (b) 7.5 mm (minimum) fibre cement planks and weatherboards must be fixed in accordance with [Figure 3.5.3.1](#) with a stud spacing of not more than 600 mm.
- (c) Acceptable fixings for 7.5 mm fibre cement planks and weatherboards are—
 - (i) for timber studs—40×2.8 mm galvanised fibre cement nails; and
 - (ii) for steel studs—8–18×35 mm self embedding head screws (see [Figure 3.5.3.1](#)).

Figure 3.5.3.1

FIXING OF WALL CLADDING

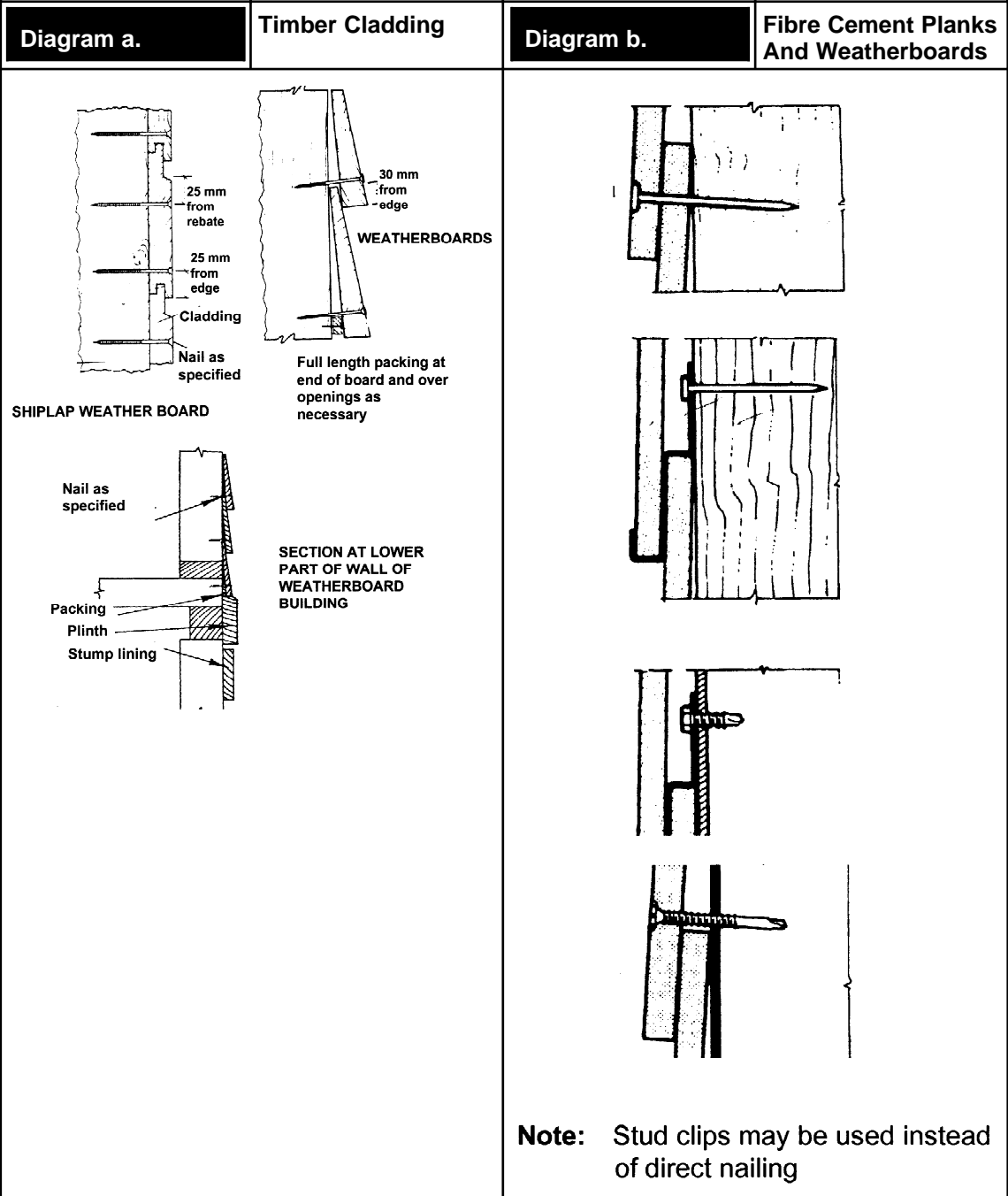

3.5.3.4 Sheet wall cladding

(a) Fibre cement sheets must comply as follows:

- (i) Fibre cement sheets used as external wall cladding must be fixed in accordance with **Table 3.5.3.1** and **Figure 3.5.3.2**.
- (ii) Where the external cladding also acts as structural sheet bracing, the lesser of the stud and fixing spacings for both applications must be used.
- (iii) External fibre cement sheets and claddings must comply with AS/NZS 2908.2 or ISO 8336.

Table 3.5.3.1 STUD AND WALL SPACINGS FOR 6mm FIBRE CEMENT SHEET WALL CLADDING

<i>Design wind speed</i>	STUD SPACING		NAIL SPACING (2.8 mm fibre cement nails)			
	Within 1.2 m of ends of building	Elsewhere	Within 1.2 m of ends of building		Elsewhere	
			Body	Edges	Body	Edges
W28	600	600	300	200	300	200
W33	600	600	200	200	300	200
W41	450	600	200	200	200	200

Figure 3.5.3.2

SHEET FIXING DETAIL

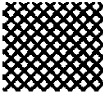
Legend:		= Nails at 300 mm spacings
		= Nails at 200 mm spacings

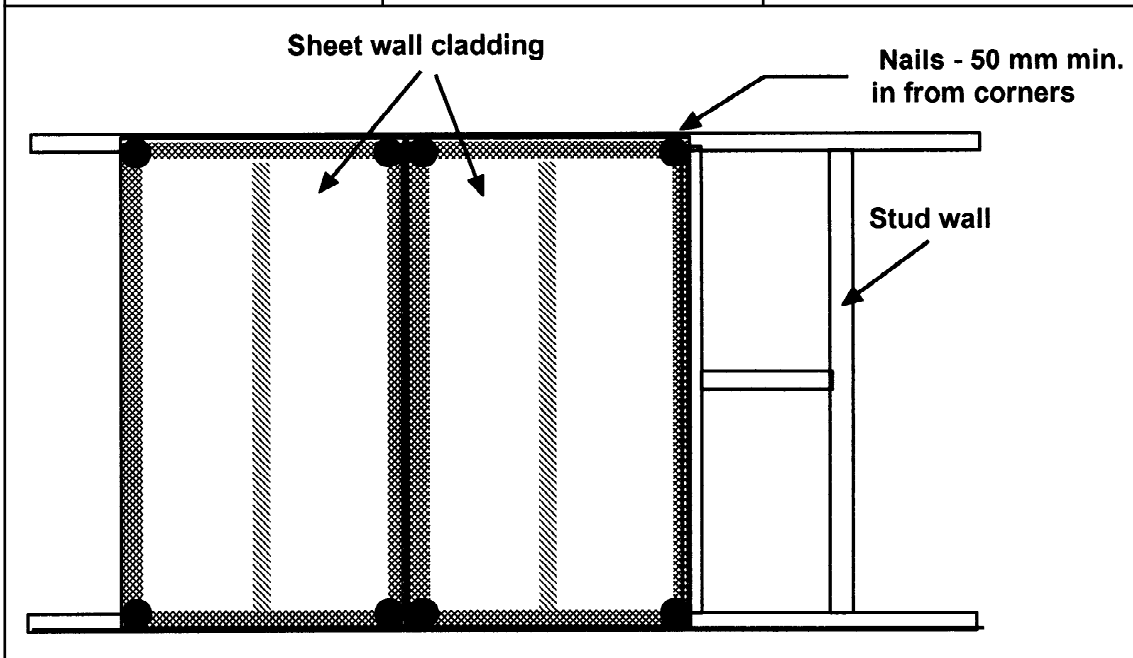

- (b) Structural plywood external cladding must comply as follows:
- (i) Structural plywood cladding must comply with AS/NZS 2269.
 - (ii) Where structural plywood acts as cladding and combined structural bracing it must comply with [Table 3.5.3.2](#).
 - (iii) Sheets, not more than 9 mm thick must be fixed using 2.8/3.5×30 mm long galvanised clouts or flat head nails spaced at—
 - (A) 150 mm centres along sheet edges; and
 - (B) 300 mm for intermediate fixings; and
 - (iv) Sheets thicker than 9 mm must be fixed with 2.8 or 3.5 mm galvanised clouts or flat head nails with a length calculated using the following formula:

$$\text{MIN NAIL LENGTH } L = PL + 10 Da$$

Where PL = Plywood thickness and
Da = Diameter of nail
 - (v) The fixings must be located not less than 9 mm from the edge of the sheet.

Explanatory information:

The above formula is applied as follows:

For 12 mm plywood and 2.8 mm diameter nail

$L = 12 + 28$ mm; therefore the nail length must be 40 mm.

Table 3.5.3.2 MINIMUM STRUCTURAL PLYWOOD THICKNESS FOR COMBINED BRACING AND EXTERNAL CLADDING (mm)

Plywood stress grade	Stud spacing (mm)					
	Plywood face grain Parallel to studs			Plywood face grain At right angles to studs		
	450	600	900	450	600	900
F8	9	12	16	7	9	12
F11	8	12	16	6	8	12
F14	7	12	16	6	7	12

3.5.3.5 Eaves and soffit linings

External fibre cement sheets and linings used as eaves and soffit linings must—

- (a) comply with AS/NZS 2908.2 or ISO 8336; and
- (b) be fixed in accordance with [Table 3.5.3.3](#) and [Figure 3.5.3.3](#) using—
 - (i) 2.8x30 mm Fibre cement nails; or
 - (ii) No. 8 Wafer head screws (for 4.5 mm and 6 mm sheets only); or
 - (iii) No. 8 Self embedding head screws (for 6 mm sheets only).

Table 3.5.3.3 TRIMMER AND FASTENER SPACINGS FOR 4.5 AND 6 mm FIBRE CEMENT EAVES AND SOFFIT LININGS

Maximum eaves Width	Design wind speed	Maximum Trimmer spacings (mm)		Maximum Fastener Spacings (mm)	
		Within 1200 mm of the external corners of the building	Remainder of sheet	Within 1200 mm of the external corners of the building	Remainder of sheet
600	W28	600	900	200	300
	W33	600	800	200	300
	W41	500	700	200	300
1200	W28	600	750	200	300
	W33	600	700	200	300
	W41	500	650	200	300

Figure 3.5.3.3
EAVES TRIMMER DETAIL

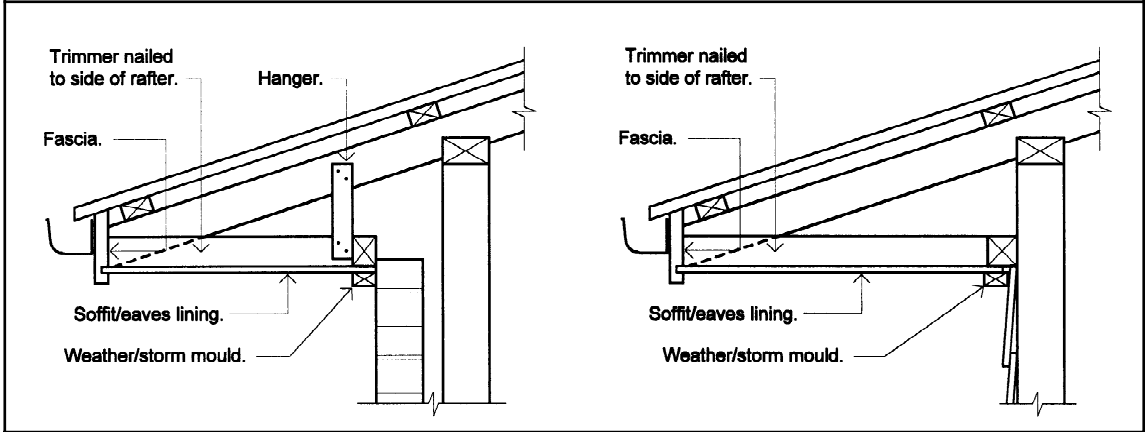

3.5.3.6 Flashings to wall openings

Openings in external wall cladding exposed to the weather must be flashed as follows:

- (a) All openings must be adequately flashed using materials that comply with AS/NZS 2904.
- (b) *Flashings* must be securely fixed at least 25 mm under the cladding and extend over the ends and edges of the framing of the opening (see [Figure 3.5.3.4](#)).

Figure 3.5.3.4
TYPICAL WINDOW FLASHING DETAIL

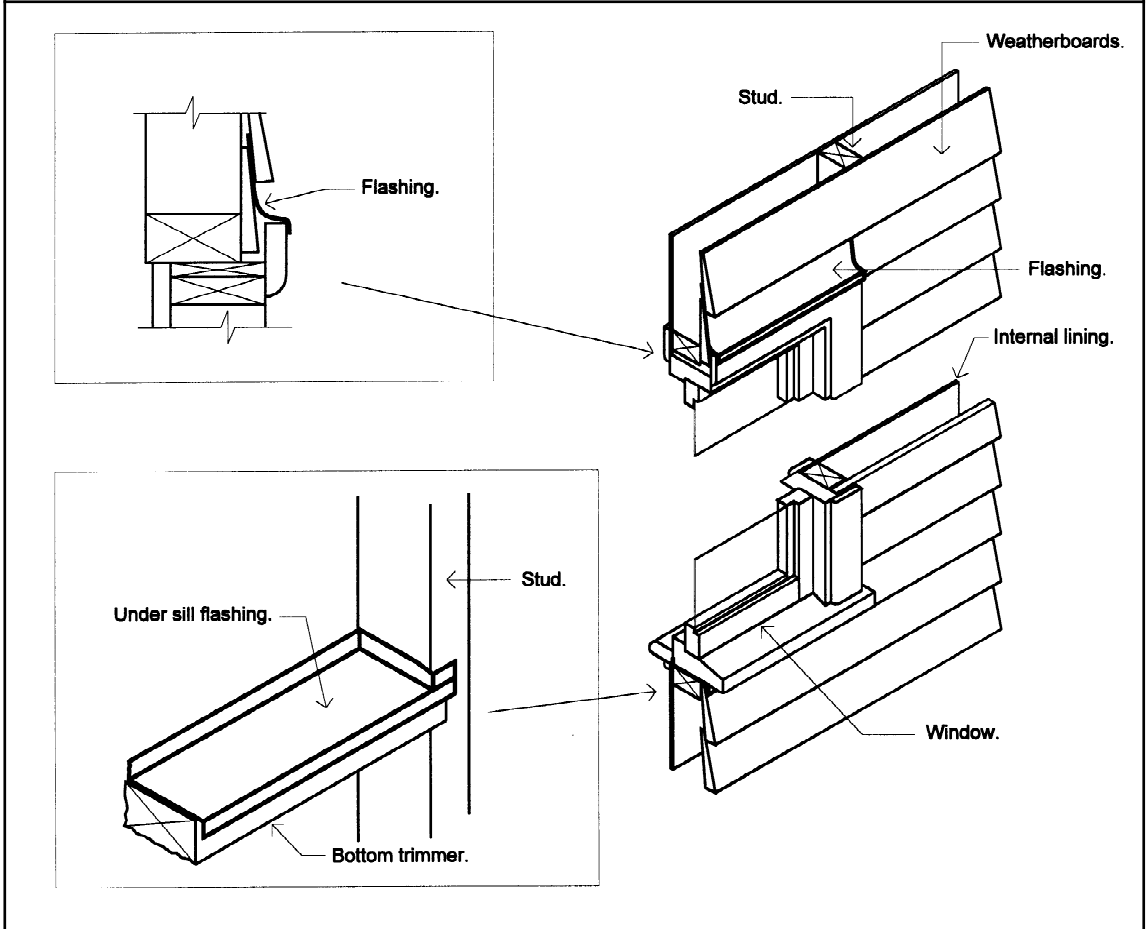

PART **3.6**

GLAZING

- 3.6 Definitions**
- 3.6.0 Acceptable Construction Manual**
- 3.6.1 Application**
- 3.6.2 Glazing Sizes and Installation**
- 3.6.3 Perimeter Framed Glazing**
- 3.6.4 Human Impact Safety Requirements**
- 3.6.5 Doors**
- 3.6.6 Side Panels**
- 3.6.7 Full Height Framed Glazed Panels**

- 3.6.8 Glazed Panels, Other than Doors or Slide Panels, on the Perimeter of Rooms**

- 3.6.9 Shower Doors, Shower Screens and Bath Enclosures**

PART 3.6 CONTENTS

PART 3.6 GLAZING

3.6 Glazing

- 3.6 Definitions
- 3.6.0 Acceptable construction manuals
- 3.6.1 Application
- 3.6.2 Glazing sizes and installation
- 3.6.3 Perimeter framed glazing
- 3.6.4 Human impact safety requirements
- 3.6.5 Doors
- 3.6.6 Side panels
- 3.6.7 Full height framed glazed panels
- 3.6.8 Glazed panels, other than doors or side panels, on the perimeter of rooms
- 3.6.9 Shower doors, shower screens and bath enclosures

PART 3.6 GLAZING

Appropriate Performance Requirements

Where an alternative glazing system is proposed as an *Alternative Solution* to that described in Part 3.6, that proposal must comply with—

- (a) *Performance Requirement* **P2.1**; and
- (b) *Performance Requirement* **P2.2.2**; and
- (c) the relevant *Performance Requirements* determined in accordance with **1.0.10**.

Definitions

3.6

The following definitions are used in this Part:

Perimeter of building means the external envelope of a building.

Unobstructed opening means a glazed area that a person could mistake for an open doorway or clearway and walk into the glazed panel.

A. Acceptable construction manuals

3.6.0

Performance Requirements **P2.1** and **P2.2.2** are satisfied for glazing and windows if designed and constructed in accordance with one of the following manuals:

- (a) AS 2047 for the following glazed assemblies in an external wall:
 - (i) Windows excluding those listed in (b).
 - (ii) Sliding doors with a frame.
 - (iii) Adjustable louvres.
 - (iv) Window walls with one piece framing.
- (b) AS 1288 for all glazed assemblies not covered by (a) and the following glazed assemblies:
 - (i) All glazed assemblies not in an external wall.
 - (ii) Hinged doors, including French doors and bi-fold doors.
 - (iii) Revolving doors.
 - (iv) Fixed louvres.

- (v) Skylights, roof lights and windows in other than the vertical plane.
- (vi) Sliding doors without a frame.
- (vii) Windows constructed on site and architectural one-off windows, which are not design tested in accordance with AS 2047.
- (viii) Second-hand windows, re-used windows, recycled windows and replacement windows.
- (ix) Heritage windows.

Explanatory information:

The reference to heritage windows in **3.6.0(b)(ix)** is intended to apply to windows in heritage buildings. The method of determining a heritage building is normally covered by the relevant State or Territory authority.

STATE AND TERRITORY VARIATIONS

3.6.0(a) is replaced by the following clause in Queensland:

- (b) AS 2047 for the following glazed assemblies in an external wall, with the exception that Tables 2.1 and 2.5 of AS 2047 are omitted and the following Tables are inserted:
 - (i) Windows excluding those listed in (b).
 - (ii) Sliding doors with a frame.
 - (iii) Adjustable louvres.
 - (iv) Window walls with one piece framing.

TABLE 2.1 WINDOW RATINGS FOR HOUSING

Window rating	Serviceability design wind pressure, Pa
N1	500
N2	700
N3, C1	1000
N4, C2	1500
N5, C3	2200
N6, C4	3000

TABLE 2.5 ULTIMATE STRENGTH TEST PRESSURES

Window rating	Ultimate strength test pressure, Pa
N1	700
N2	1000
N3, C1	1500
N4, C2	2300
N5, C3	3300
N6, C4	4500

B. Acceptable construction practice

3.6.1 Application

Compliance with this Part satisfies *Performance Requirements* **P2.1** and **P2.2.2** for glazing, provided—

- (a) the building is located in an area with a *design wind speed* of not more than W41; and

Explanatory information:

1. Information on *design wind speeds* for particular areas may be available from the *appropriate authority*.
2. For glazing in *high wind areas* refer to **Part 3.10.1**.

- (b) glass is manufactured in accordance with AS 1288; and
- (c) safety glazing must be legibly marked in accordance with AS 1288; and
- (d) glazing used in balustrades and sloped overhead glazing complies with AS 1288.

3.6.2 Glazing sizes and installation

Glazing used in buildings must comply with the following:

- (a) Glazing used in the *perimeter of buildings* and supported on all sides must comply with the appropriate provisions listed in **3.6.3**.
- (b) Glazing used in areas where the potential for human impact could occur must comply with the appropriate provisions listed in **3.6.4**.

3.6.3 Perimeter framed glazing (supported on all sides)

Glazing installed in the *perimeter of buildings* must comply with—

- (a) for ordinary annealed fully framed glass—**Table 3.6.1** (see also **Figure 3.6.2**); and
- (b) for ordinary annealed patterned fully framed glass—**Table 3.6.1**.

Explanatory information:

For other types of perimeter glazing including toughened, wired, laminated and unframed glazing refer to AS 1288.

Table 3.6.1 FULLY FRAMED GLASS—MAXIMUM AREAS IN SQUARE METRES

Minimum nominal thickness (mm)	<i>Design Wind Speed</i>		
	W28	W33	W41
Ordinary annealed fully framed glass			
3	2.0	1.4	1.0

Minimum nominal thickness (mm)	Design Wind Speed		
	W28	W33	W41
4	3.5	2.4	1.7
5	5.2	3.6	2.6
6	7.4	5.2	3.6
8	11.0	7.9	5.4
Ordinary annealed, patterned, fully framed glass			
3	1.7	1.1	0.8
4	3.0	2.1	1.5
5	4.8	3.3	2.4
6	6.6	4.8	3.5

3.6.4 Human impact safety requirements

The thickness and type of glazing installed in areas of a building that have a high potential for human impact (an area of a building frequented by the occupants during everyday activities in which a person could fall into or against the glazed panel) must comply as follows:

- (a) Doors—in accordance with [3.6.5](#).
- (b) Door side panels—in accordance with [3.6.6](#).
- (c) Full height glass panels—in accordance with [3.6.7](#).
- (d) Glazed panels, other than doors or side panels, on the perimeter of rooms—in accordance with [3.6.8](#).
- (e) Shower screens, shower doors and bath enclosures—in accordance with [3.6.9](#).

3.6.5 Doors

Glass (except leadlight panels) in doors must be Grade A safety glazing material in accordance with [Table 3.6.3](#) and [Figure 3.6.1](#), except that—

- (a) in fully framed panels, ordinary annealed glass with a maximum area of 0.5 m² in accordance with [Table 3.6.4](#) may be used provided a chair rail not less than 40 mm wide is installed in the door; and
- (b) unframed doors must be glazed with toughened safety glass with a standard nominal thickness of not less than 10 mm; and
- (c) doors to showers and bath enclosures must be glazed in accordance with [3.6.9](#).

3.6.6 Side panels

- (a) All framed glass (except leadlight panels) in side panels with their nearest vertical sight line less than 300 mm from the nearest edge of the doorway opening must be of Grade A safety glazing material in accordance with [Table 3.6.3](#) and [Figure 3.6.1](#), except that—
 - (i) where the lowest visible sight line is 1.2 m or greater above the highest abutting finished floor level, ordinary annealed glass in accordance with [Table 3.6.2](#) may be used; or

- (ii) where the lowest visible sight line is less than 1.2 m above the highest abutting finished floor level, ordinary annealed glass in accordance with [Table 3.6.4](#), with an area of not more than 0.5 m², may be used; or
- (iii) where the side panel consists of glass louvres with exposed edges or where the louvres are installed less than 500 mm above the highest abutting finished floor level—
 - (A) for blade widths not greater than 230 mm, Grade A toughened safety glazing not less than 5 mm thick; and
 - (B) for blade widths greater than 230 mm, Grade A toughened safety glazing not less than 10 mm thick.
- (b) Framed glass panels with the nearest vertical sight line not less than 300 mm from the nearest edge of the door opening are not considered to be side panels for the purposes of the *Housing Provisions*.

Table 3.6.2 MAXIMUM AREAS OF ORDINARY ANNEALED GLASS IN SIDE PANELS

Minimum nominal thickness (mm)	Maximum area of pane (m ²)
3	0.8
4	1.4
5	2.2
6	3.3

3.6.7 Full height framed glazed panels

- (a) A glazed panel located in a building so that it is capable of being mistaken for an *unobstructed opening* must be glazed with—
 - (i) Grade A safety glazing material in accordance with [Table 3.6.3](#), or
 - (ii) ordinary annealed glass complying with [Table 3.6.3](#) provided the glazed area is not greater than 0.9 m².
- (b) Glazed panels are not considered capable of being mistaken for an *unobstructed opening* where any of the following apply:
 - (i) The clear opening width is not more than 500 mm.
 - (ii) The lowest sight line of the opening is not less than 500 mm above the highest abutting finished floor level.
 - (iii) The glass is marked by means of a permanent motif or other decorative treatment on or etched into the glass, of sufficient magnitude to be readily apparent, or the glass is opaquely coloured or patterned to indicate its presence.
 - (iv) A chair rail or handrail not less than 40 mm thick, or the like is provided at a height of 865 mm above the adjoining ground level.
 - (v) Internal partitions clearly form walls of a passageway and conform with item (a).
 - (vi) The difference in floor level on either side of the panel is greater than 500 mm.

Figure 3.6.1

IDENTIFICATION OF GLAZING REQUIREMENTS FOR DOORS AND SIDE PANELS

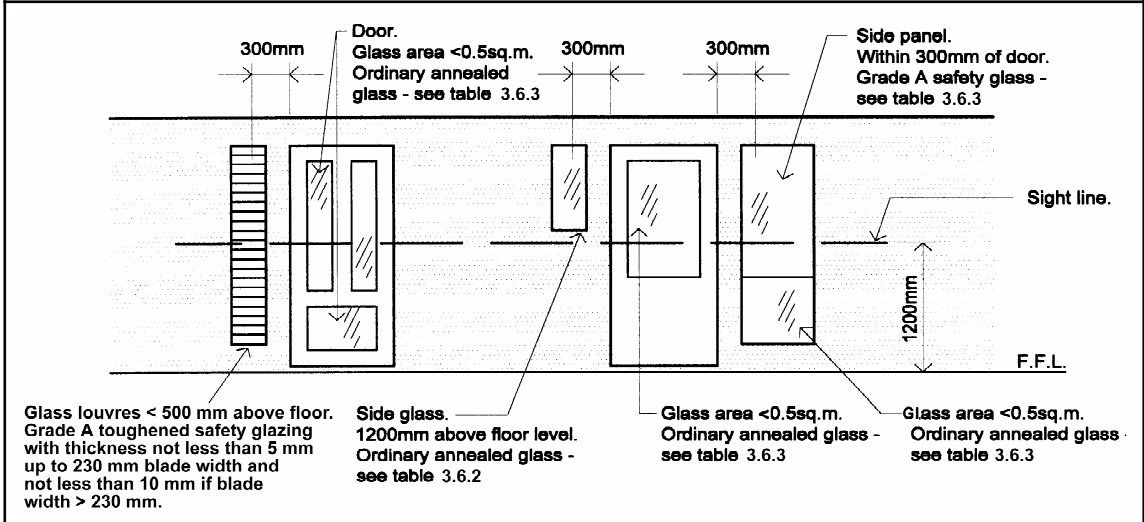

TABLE 3.6.3 MAXIMUM AREAS OF GLAZING MATERIAL FOR FRAMED GLASS DOORS, FRAMED GLASS SIDE PANELS, AND OTHER FRAMED GLAZED PANELS

Type of Glass	Minimum nominal thickness (mm)	Maximum area of pane (m ²)
Patterned or clear ordinary annealed glass	3	0.1
	4	0.3
	5	0.5
	6	0.9
Grade A Toughened safety glass	3	1
	4	2
	5	3
	6	4
Grade A Laminated safety glass	5.38	2
	6.38	3
	8.38	5

3.6.8 Glazed panels, other than doors or side panels, on the perimeter of rooms

All framed glazing where the lowest sight line of the glazing panel is less than 500 mm from the highest abutting finished floor level must be—

- (a) Grade A safety glazing material in accordance with [Table 3.6.3](#); or
- (b) ordinary annealed glass in accordance with [Table 3.6.4](#) (see also [Figure 3.6.2](#)).

TABLE 3.6.4 MAXIMUM AREAS OF ORDINARY ANNEALED GLASS WHERE THE LOWEST SIGHT LINE IS LESS THAN 500 MM FROM THE HIGHEST ABUTTING FLOOR LEVEL

Minimum nominal thickness (mm)	Maximum area of pane (m ²)
3	0.1
4	0.3
5	2.0

Figure 3.6.2

IDENTIFICATION OF GLAZING REQUIREMENTS FOR GLAZED PANELS

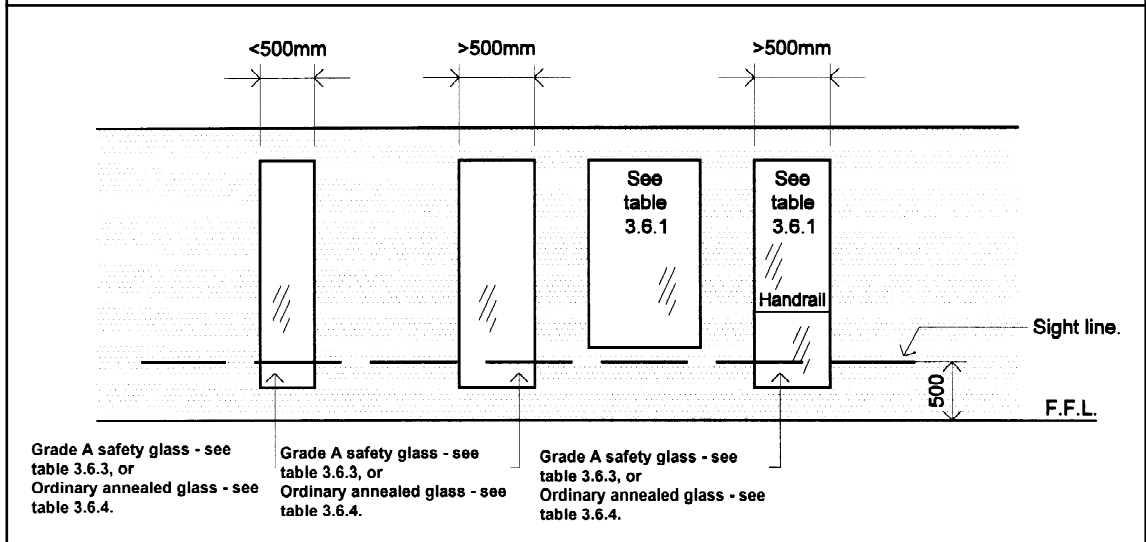

3.6.9 Shower doors, shower screens and bath enclosures

- (a) All shower doors, shower screens, bath enclosures, and associated *windows*, where the lowest sight line is less than 1.5 m above the highest abutting finished level of the floor, bottom of the bath, or shower base, must—
 - (i) for framed panels, be glazed with—
 - (A) Grade A safety glazing material in accordance with [Table 3.6.3](#); or
 - (B) Grade B safety glazing material in accordance with [Table 3.6.5](#); or
 - (ii) for panels or doors with any edge exposed must be toughened safety glass in accordance with [Table 3.6.3](#) with a minimum nominal thickness of 5 mm.
- (b) For the purposes of this part—
 - (i) a *window* is part of a bath enclosure or shower if it is less than 500 mm horizontally from the internal perimeter of the floor of the bath or shower (see [Figure 3.6.3](#)); and
 - (ii) a *window* is not part of the bath or shower if a person in the bath or shower is protected from the *window* by permanent safety glazing or permanent material able to resist human impact.

- (c) Associated *windows* referred to in (b) (i), in *external walls* may incorporate annealed glass panels of not less than 4 mm thickness, provided that they are not more than 0.1 m² in area.

Explanatory information:

Care should be taken when using showers fitted with safety wired glass, safety organic-coated glass, and laminated safety glass products that are liable to damage from thermal shock. Thermal shock occurs from hot water from the shower hitting the shower screen during cold weather.

TABLE 3.6.5 MAXIMUM AREAS OF GRADE B SAFETY GLAZING MATERIALS FOR SHOWER DOORS, SHOWER SCREENS AND BATH ENCLOSURES

Type of Glass	Standard nominal thickness (mm)	Maximum area of pane (m ²)	Area (Fig. 3.6.3)
Safety wired glass	Greater than or equal to 6	2.5	A, B, C
Safety organic coated glass	3	1	A, B, C, D
	4	1.5	
	5	2	
	Greater than or equal to 6	3	

Figure 3.6.3

IDENTIFICATION OF GLAZING REQUIREMENTS FOR SHOWER DOORS, SHOWER SCREENS AND BATH ENCLOSURES

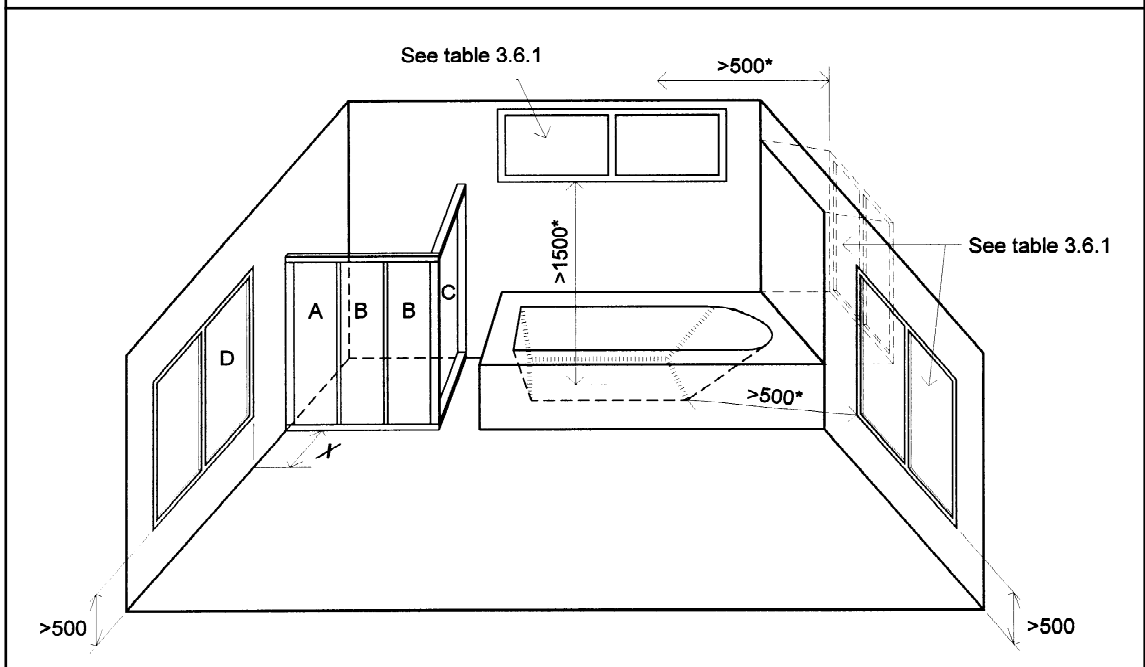

PART **3.7**

FIRE SAFETY

- 3.7.1 Fire Separation**
- 3.7.2 Smoke Alarms**
- 3.7.3 Heating Appliances**
- 3.7.4 Bushfire Areas**
- 3.7.5 Alpine Areas**

PART 3.7 CONTENTS

PART 3.7 FIRE SAFETY

3.7.1 Fire separation

- 3.7.1.1 Application
- 3.7.1.2 General concession—non-combustible materials
- 3.7.1.3 External walls of Class 1 buildings
- 3.7.1.4 Measurement of distances
- 3.7.1.5 Construction of external walls
- 3.7.1.6 Class 10a buildings
- 3.7.1.7 Allowable encroachments
- 3.7.1.8 Separating walls
- 3.7.1.9 Fire hazard properties
- 3.7.1.10 Roof lights

3.7.2 Smoke alarms

- 3.7.2.1 Application
- 3.7.2.2 Requirements for smoke alarms
- 3.7.2.3 Location—Class 1a buildings
- 3.7.2.4 Location—Class 1b buildings
- 3.7.2.5 Lighting to assist evacuation—Class 1b buildings

3.7.3 Heating appliances

- 3.7.3.0 Acceptable construction manuals
- 3.7.3.1 Application
- 3.7.3.2 Open fireplace construction
- 3.7.3.3 Chimney construction
- 3.7.3.4 Installation of insert fireplaces and flues
- 3.7.3.5 Installation of free standing heating appliances

3.7.4 Bushfire areas

- 3.7.4.0 Acceptable construction manuals
- 3.7.4.1 Application
- 3.7.4.2 Categories of bushfire attack
- 3.7.4.3 Construction requirements

3.7.5 Alpine areas

- 3.7.5.1 Application
- 3.7.5.2 External doorways
- 3.7.5.3 External ramps
- 3.7.5.4 Discharge of external doorways providing a means of egress
- 3.7.5.5 External trafficable structures

PART 3.7.1 FIRE SEPARATION

Appropriate Performance Requirements

Where an alternative fire separation design is proposed as an *Alternative Solution* to that described in Part 3.7.1, that proposal must comply with—

- (a) *Performance Requirement* **P2.3.1**; and
- (b) the relevant *Performance Requirements* determined in accordance with **1.0.10**.

Acceptable construction practice

3.7.1.1 Application

Compliance with this Part satisfies *Performance Requirement* **P2.3.1** for fire separation.

3.7.1.2 General concession—non-combustible materials

The following materials, though *combustible* or containing *combustible* fibres, may be used wherever a *non-combustible* material is *required* in the *Housing Provisions*—

- (a) plasterboard; and
- (b) perforated gypsum lath with a normal paper finish; and
- (c) fibrous-plaster sheet; and
- (d) fibre-reinforced cement sheeting; and
- (e) pre-finished metal sheeting having a *combustible* surface finish not exceeding 1 mm thick and where the *Spread-of-Flame Index* of the product is not more than 0; and
- (f) bonded laminated materials where—
 - (i) each laminate is *non-combustible*; and
 - (ii) each adhesive layer is not more than 1 mm thick; and
 - (iii) the total thickness of adhesive layers is not more than 2 mm; and
 - (iv) the *Spread-of-Flame Index* and the *Smoke-Developed Index* of the laminated material as a whole does not exceed 0 and 3 respectively.

3.7.1.3 External walls of Class 1 buildings

An *external wall* of a Class 1 building, and any openings in that wall, must comply with **3.7.1.5** if the wall is less than—

- (a) 900 mm from an allotment boundary other than the boundary adjoining a road alignment or other public space; or

- (b) 1.8 m from another building on the same allotment other than an appurtenant Class 10 building or a detached part of the same Class 1 building.

3.7.1.4 Measurement of distances

- (a) The distance from any point on an *external wall* of a building to an allotment boundary or another building is the distance to that point measured along a line at right angles from the allotment boundary or *external wall* of the other building which intersects that point without being obstructed by a wall complying with [3.7.1.5](#).
- (b) Where a wall within a specified distance is *required* to be constructed in a certain manner, only that part of the wall (including any openings) within the specified distance need be constructed in that manner.

(see [Figure 3.7.1.1](#) and [3.7.1.2](#))

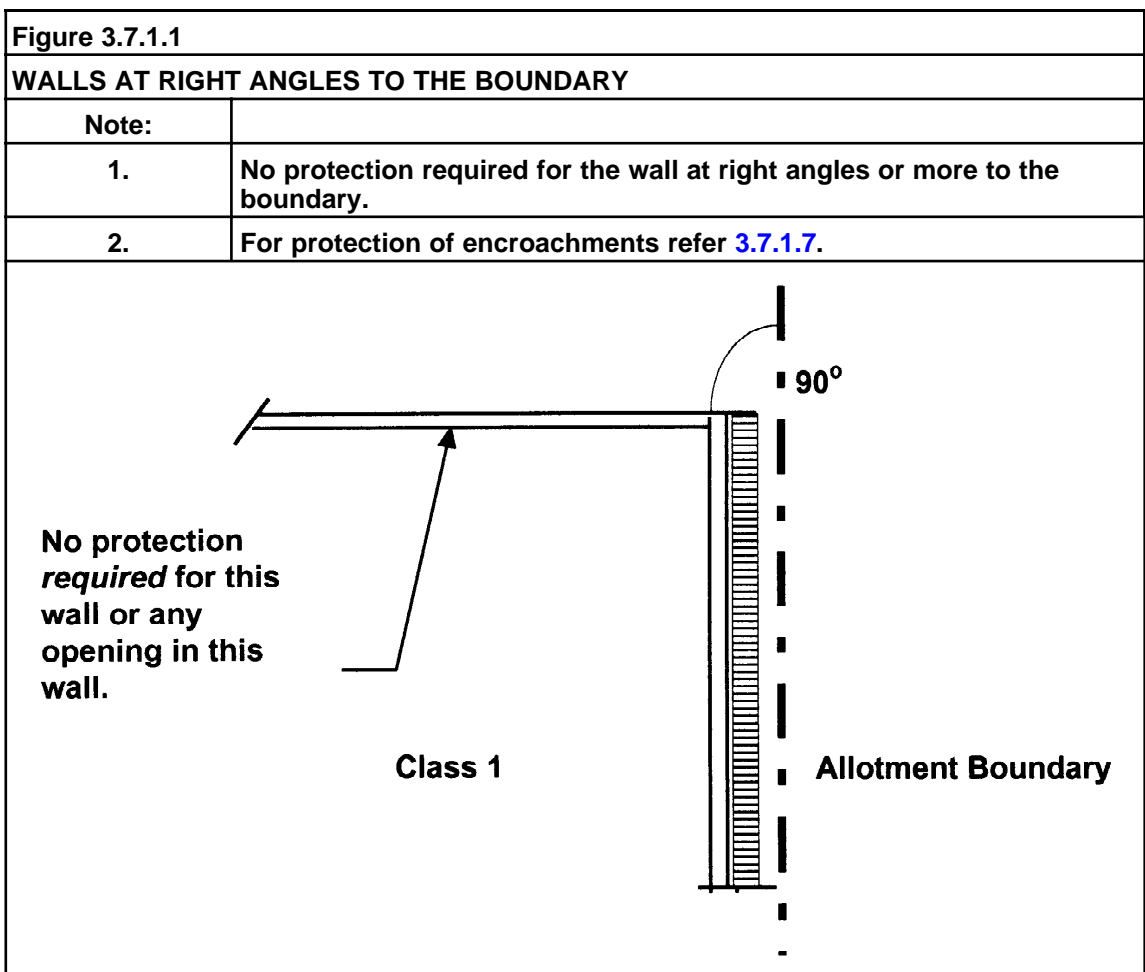

3.7.1.5 Construction of external walls

- (a) *External walls* (including gables) *required* to be *fire resisting* (referred to in [3.7.1.3](#) or [3.7.1.6](#)) must extend to the underside of a *non-combustible* roof covering or *non-combustible* eaves lining (See [Figure 3.7.1.3\(a\)](#) and [\(b\)](#)) and must—

- (i) have an FRL of not less than 60/60/60 when tested from the outside; or
- (ii) be of masonry-veneer construction in which the external masonry veneer is not less than 90 mm thick; or
- (iii) be of masonry construction not less than 90 mm thick.

Explanatory information:

The intent of the typical methods of construction shown in Figures 3.7.1.3(a) and (b) is to ensure that no gap exists between an *external wall required* to be fire-resisting and the underside of a *non-combustible roof covering or eaves*. Other forms of construction may also be acceptable provided that they achieve this intent.

See **Figure 3.7.1.10** and **3.8.6.3** for internal *separating wall* construction under one common roof.

Figure 3.7.1.2

MEASUREMENT OF DISTANCES (Plan view)

Note:	Setback distance is measured at right angles to the boundary.
--------------	--

Diagram a.

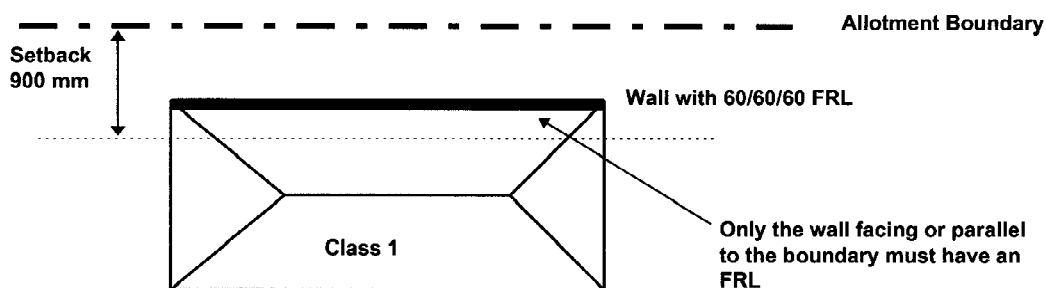
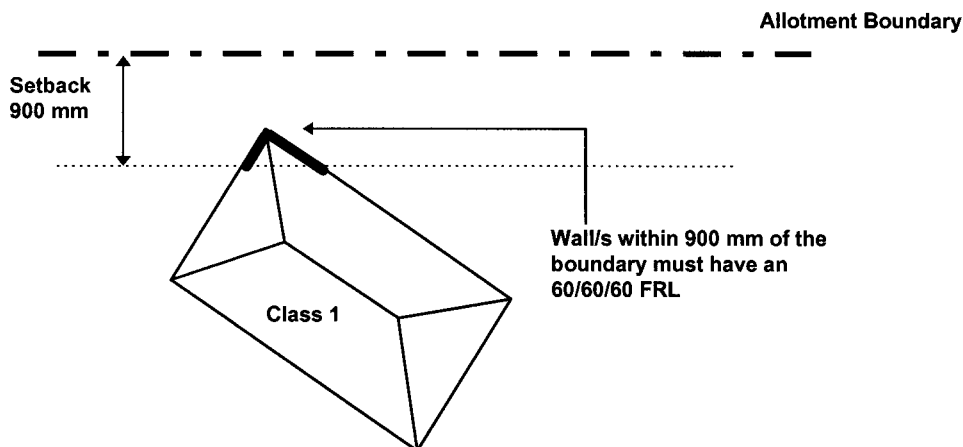

Diagram b.



- (b) Openings in *external walls* required to be *fire resisting* (referred to in 3.7.1.3 or 3.7.1.6) must be protected by—
- (i) non-openable fire *windows* or other construction with an FRL of not less than -/60/-; or
 - (ii) *self-closing* solid core doors not less than 35 mm thick.
- (c) Sub-floor vents, roof vents, weepholes and penetrations for pipes, conduits and the like need not comply with (b).
- (d) Concessions for non-*habitable* room *windows*
- Despite the requirements in (b), in a non-*habitable* room, a *window* that faces the boundary of an adjoining allotment may be not less than 600 mm from that boundary or, where the window faces another building on the same allotment, not less than 1200 mm from that building provided that—
- (i) in a bathroom, laundry or toilet, the opening has an area of not more than 1.2 m²; or
 - (ii) in a room other than referred to in (i), the opening has an area of not more than 0.54 m² and—
 - (A) the *window* is steel-framed, there are no opening sashes and it is glazed in wired glass; or
 - (B) the opening is enclosed with translucent hollow glass blocks.

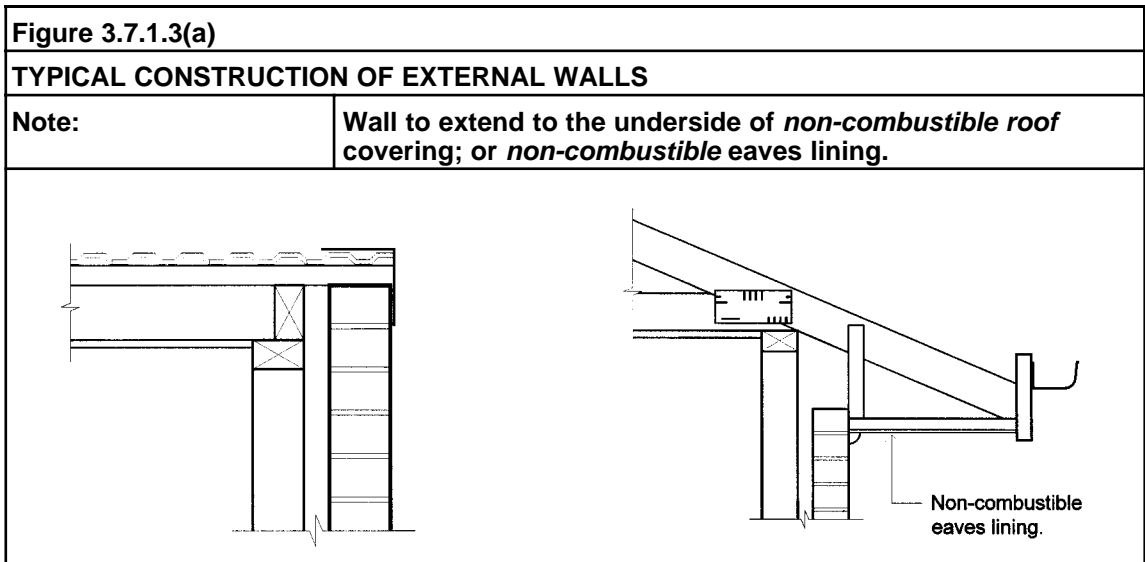
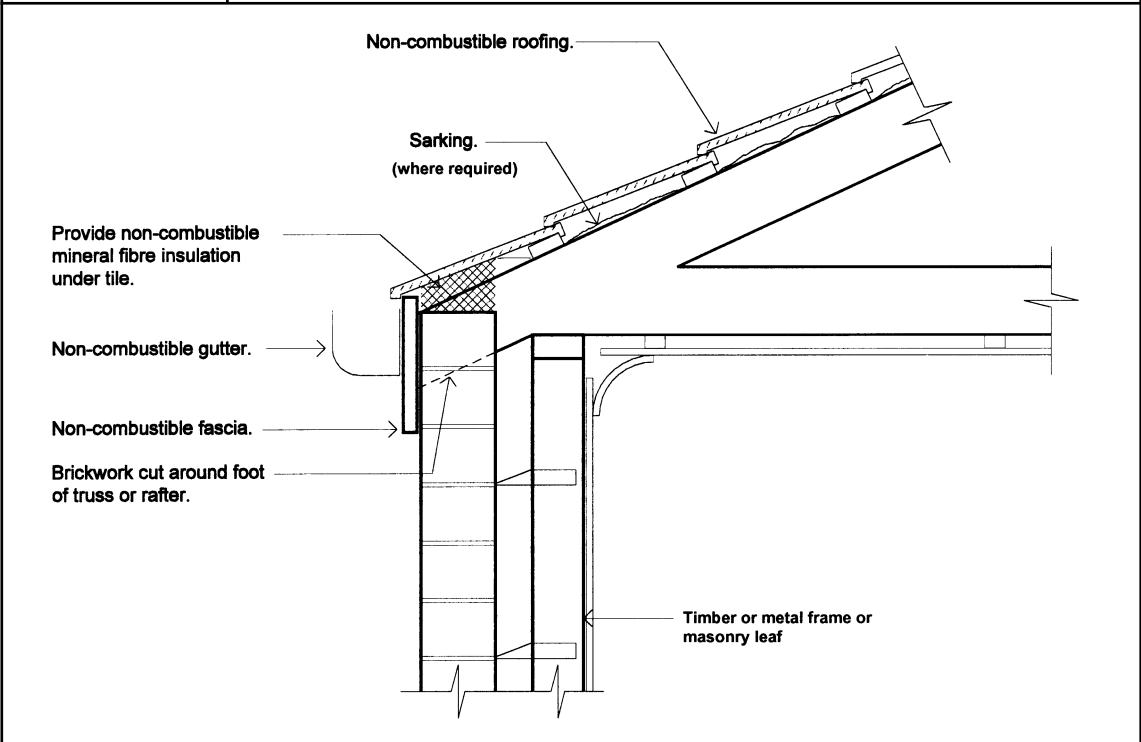

Figure 3.7.1.3(b)

TYPICAL CONSTRUCTION OF EXTERNAL WALLS

Notes:

- | | |
|-----------|---|
| 1. | The external wall must extend to the underside of a non-combustible roof covering; or non-combustible eaves lining. |
| 2. | Where sarking is installed it must be located so that ponding of water is avoided between the fascia and the first roofing batten. |



3.7.1.6 Class 10a buildings

- (a) Where a Class 10a building is located between a Class 1 building and the allotment boundary, other than the boundary adjoining a road alignment or other public space, the Class 1 building must be protected by one of the following methods shown in [Figure 3.7.1.4](#).
- (b) Where a Class 10a building is located between a Class 1 building to which it is appurtenant and another building on the same allotment, the Class 1 building must be protected by one of the methods shown in [Figure 3.7.1.5](#).
- (c) Where two or more Class 10a buildings on the same allotment are appurtenant to different Class 1 buildings, the Class 10a buildings must be separated in accordance with one of the methods shown in [Figure 3.7.1.6](#).

Figure 3.7.1.4

PROTECTION OF CLASS 1 BUILDINGS—CLASS 10a BETWEEN CLASS 1 AND THE ALLOTMENT BOUNDARY

Legend:

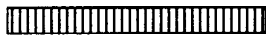

Wall with an FRL of 60/60/60



Allotment boundary

a. 900 mm from allotment boundary

The Class 10a building is not less than 900 mm from the allotment boundary, other than the boundary adjoining a road alignment or other public space.

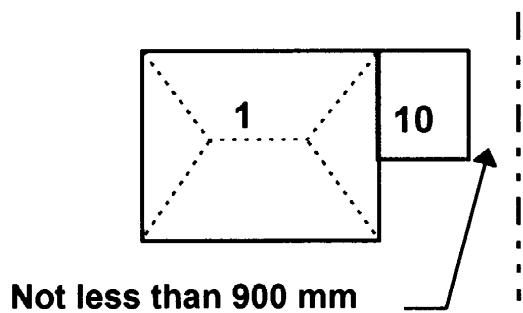

b. External wall to Class 10a building with FRL

An *external wall* of the Class 10a building which is less than 900 mm from an allotment boundary, other than the boundary adjoining a road alignment or other public space, complies with [3.7.1.5](#).

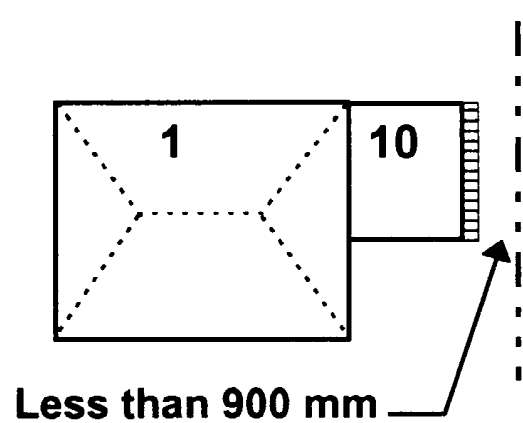

c. External wall to Class 10a building with FRL

An *external wall* of the Class 10a building which is less than 900 mm from the Class 1 building complies with [3.7.1.5](#).

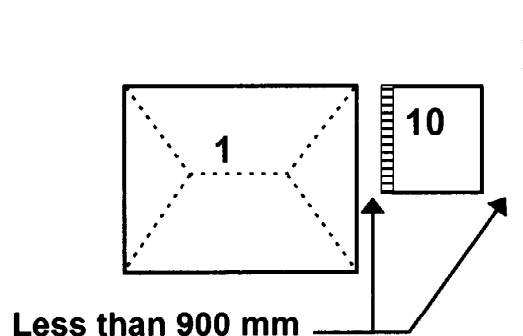

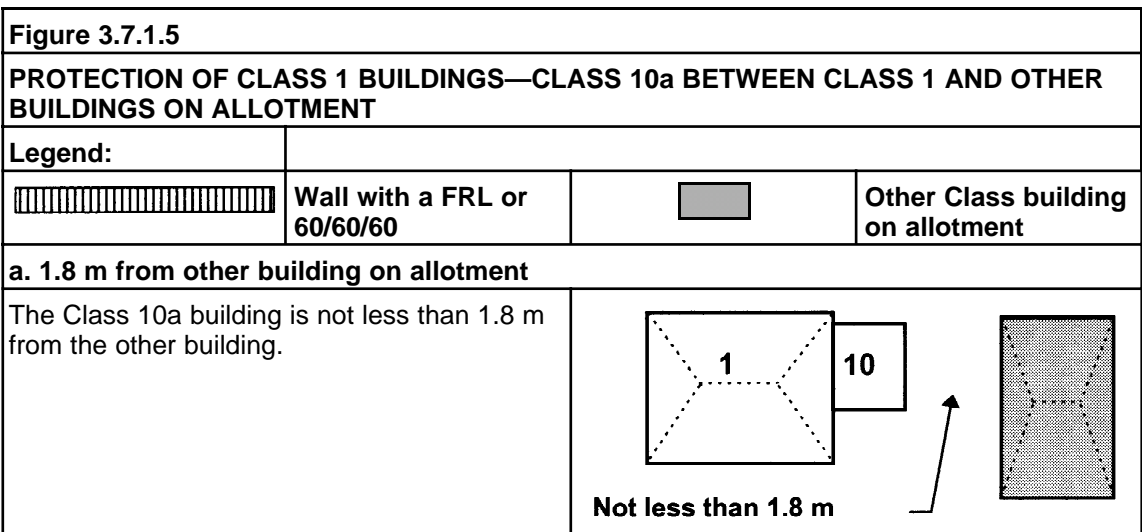
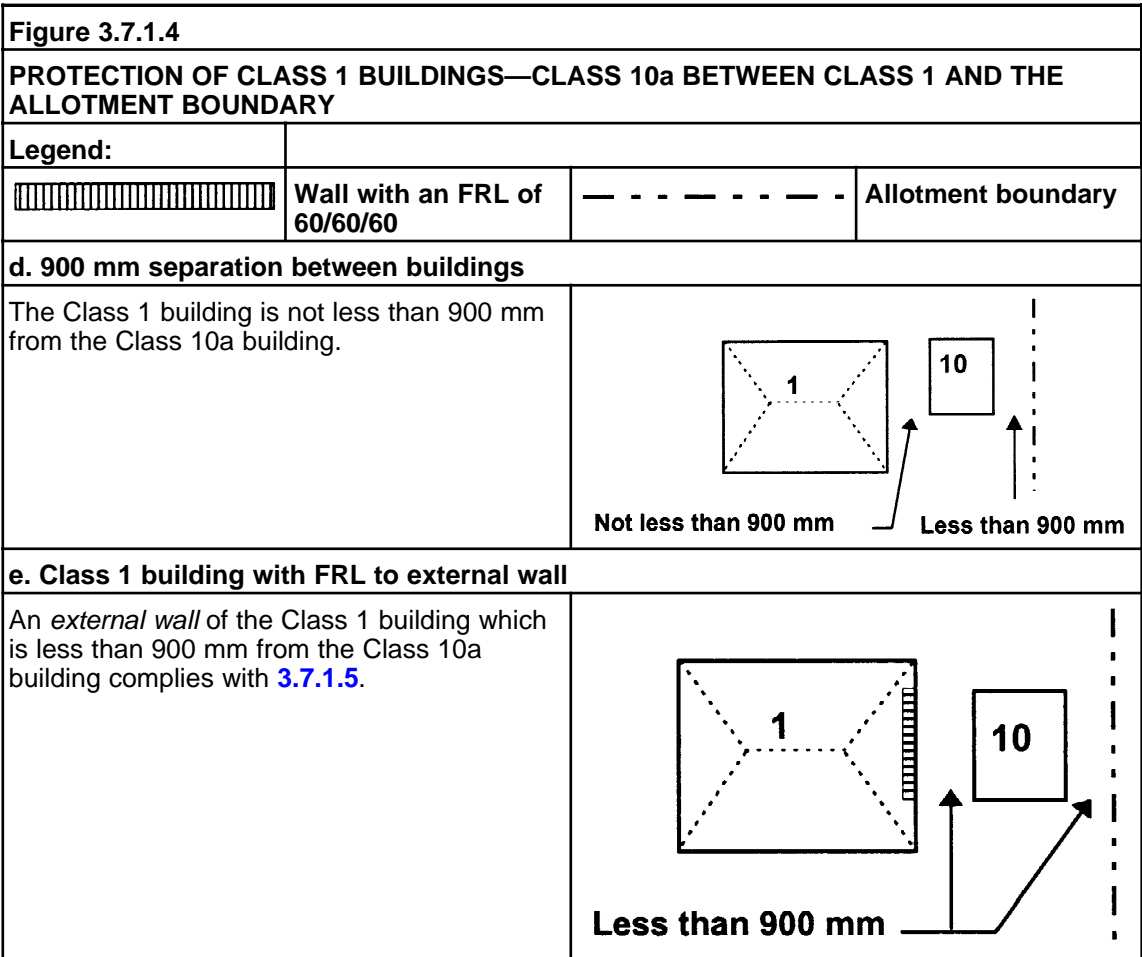

Figure 3.7.1.5

PROTECTION OF CLASS 1 BUILDINGS—CLASS 10a BETWEEN CLASS 1 AND OTHER BUILDINGS ON ALLOTMENT

Legend:



Wall with a FRL or 60/60/60



Other Class building on allotment

b. External wall to Class 10a building with FRL

An *external wall* of the Class 10a building which is less than 1.8 m from the other building complies with [3.7.1.5](#).

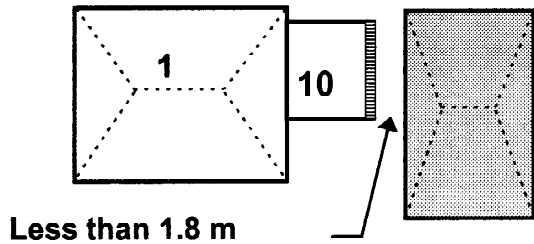

c. External wall to Class 10a building with FRL

An *external wall* of the Class 10a building which is less than 1.8 m from the Class 1 building complies with [3.7.1.5](#).

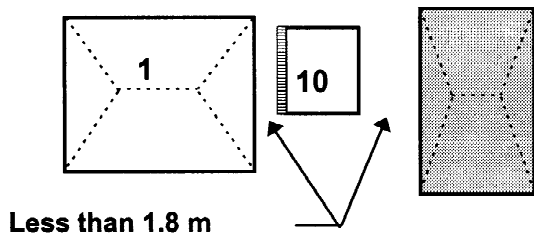

d. 1.8 m separation between Class 1 and 10a

The Class 1 building is not less than 1.8 m from the Class 10a building.

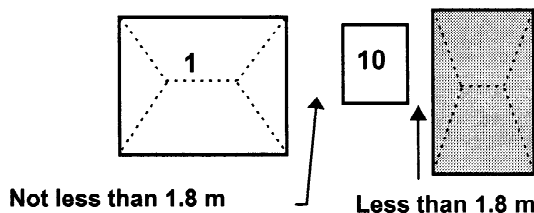

e. Class 1 building with FRL to external wall

An *external wall* of the Class 1 building which is less than 1.8 m from the Class 10a building complies with [3.7.1.5](#).

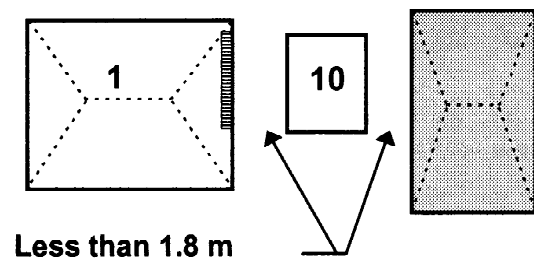

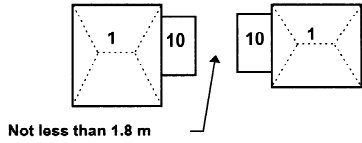
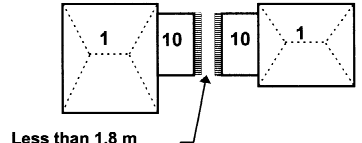
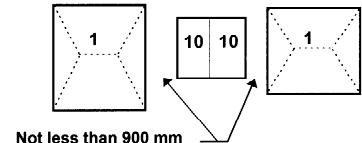
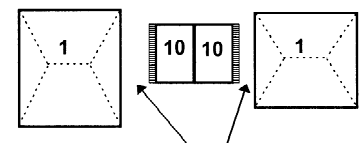
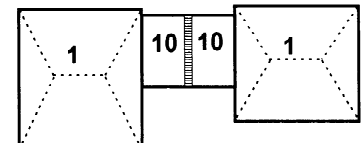
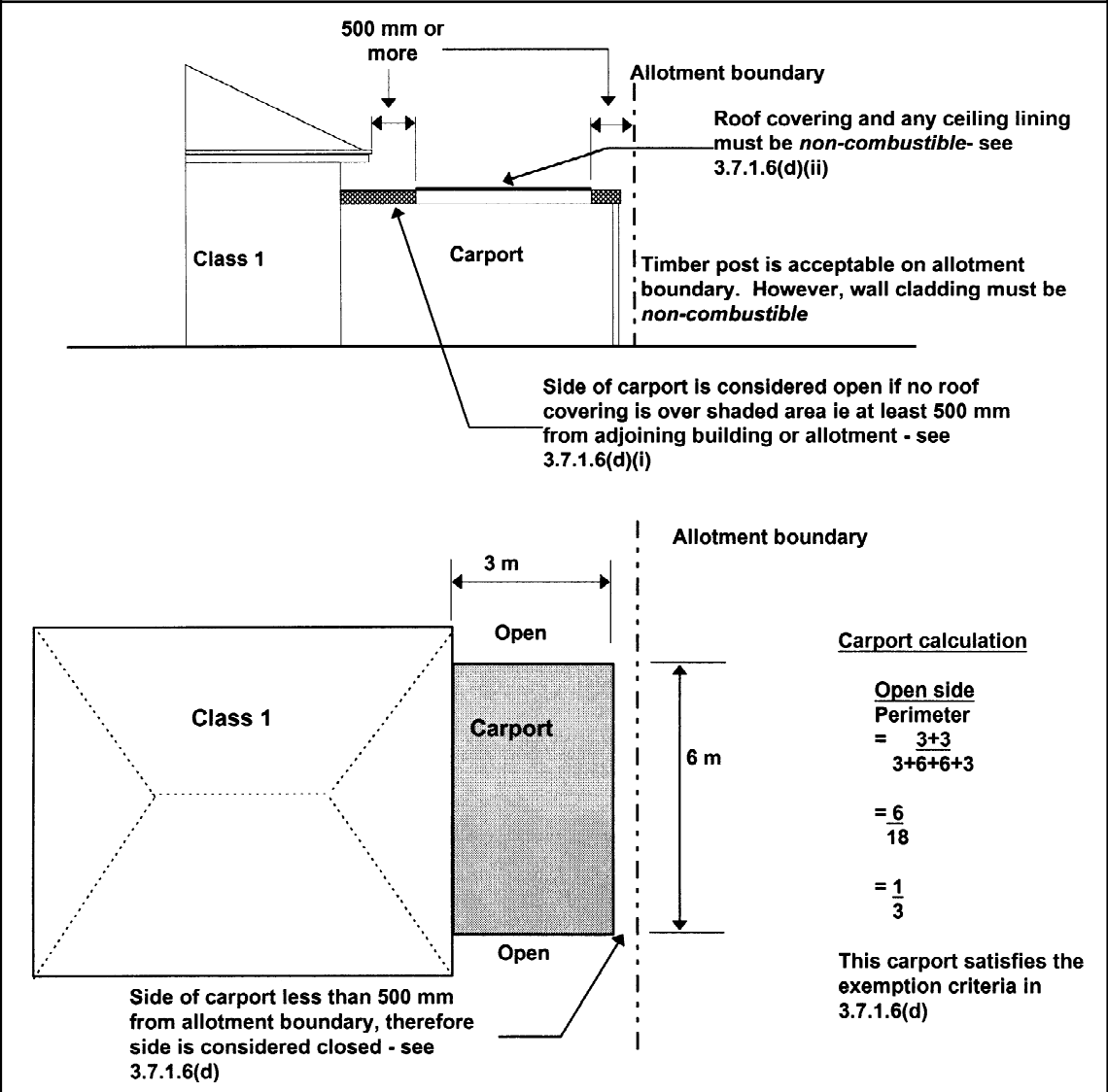

Figure 3.7.1.6	
PROTECTION OF CLASS 1 BUILDINGS—SEPARATION OF CLASS 10a BUILDINGS ON AN ALLOTMENT	
Legend:	 Wall with a FRL or 60/60/60
a. 1.8 m between Class 10a buildings	
Each 10a must be separated from each other by a distance of not less than 1.8 m.	
b. External wall to Class 10a building with FRL	
Each 10a must be separated from each other by <i>external walls</i> complying with 3.7.1.5 .	
c. 900 mm separation between Class 10a and Class 1 buildings	
Each 10a must be separated from each Class 1 building by a distance of not less than 900 mm.	
d. External wall to Class 10a buildings with FRL	
Each 10a must be separated from each Class 1 building by <i>external walls</i> complying with 3.7.1.5 .	
e. Class 10a buildings with FRL to separating wall	
Each 10a must be separated by a wall complying with 3.7.1.8 .	

- (d) A carport is exempt from (a), (b) and (c) if—
- (i) it has two or more sides open and not less than one third of its perimeter open and, for the purposes of this clause, a side is considered to be open if the roof covering adjacent to that side is not less than 500 mm from another building or allotment boundary; and
 - (ii) it has a *non-combustible* roof covering and any ceiling lining and wall cladding, including gables, is also *non-combustible* (see [Figure 3.7.1.7](#)); and

Figure 3.7.1.7

IDENTIFYING AN OPEN CARPORT



- (iii) it does not provide direct vertical support to any part of the Class 1 building; and
- (iv) in the case where it has a common roof structure with the Class 1 building and the carport does not have a ceiling (see [Figure 3.7.1.8](#)), the opening between the top of the wall of the Class 1 building and the underside of the roof covering is infilled with—
 - (A) a *non-combustible* material; or
 - (B) construction clad with *non-combustible* material on the carport side.

Figure 3.7.1.8

REQUIREMENTS FOR NON-COMBUSTIBLE INFILL PANELS TO CARPORT

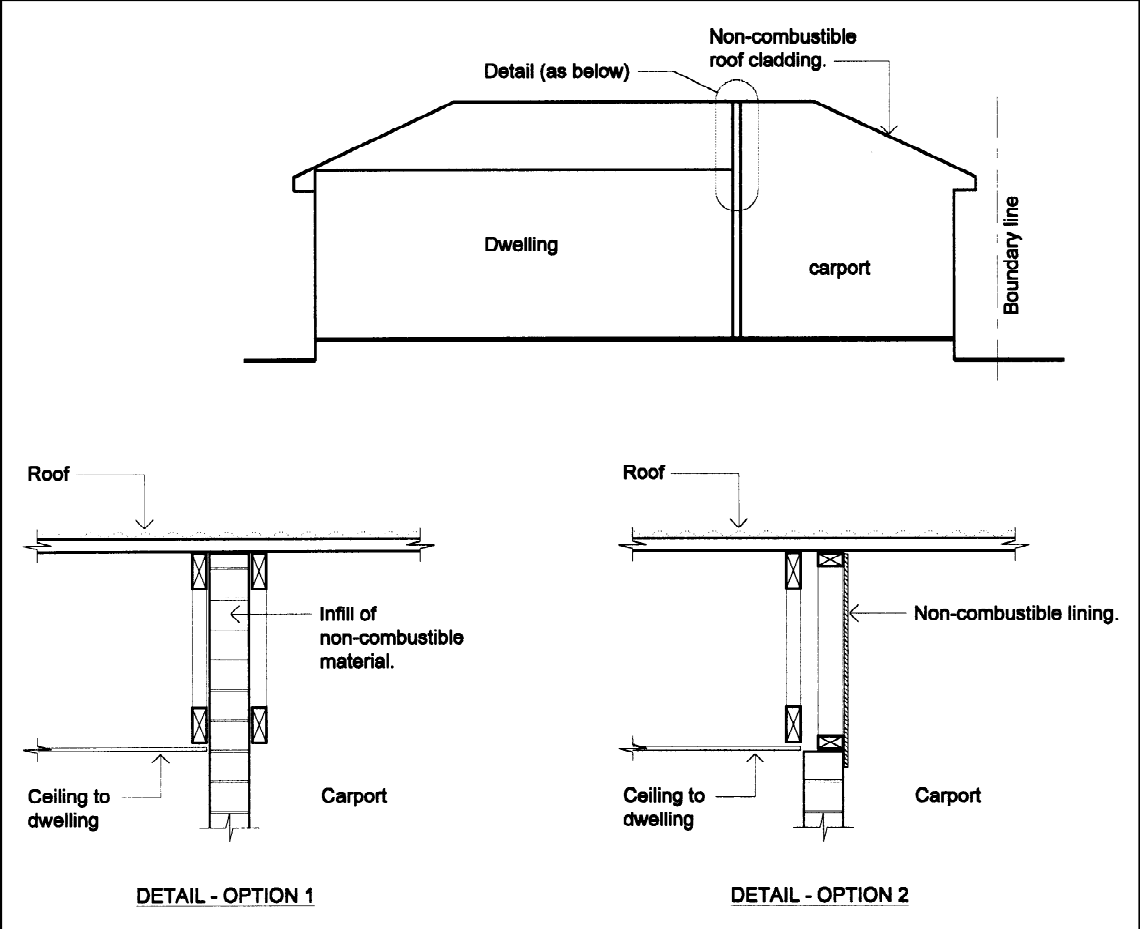

(e) Class 10a buildings must not significantly increase the risk of spread of fire between Class 2 to 9 buildings.

3.7.1.7 Allowable encroachments

- (a) An encroachment is any construction between the *external wall* of the building and the allotment boundary other than a boundary adjoining a road or other public space, or the *external walls* of two buildings on the same allotment and relates to any *external wall* of—
 - (i) a Class 10a building required to comply with 3.7.1.5; or
 - (ii) a Class 1 building.
- (b) The encroachments allowed within 900 mm of an allotment boundary or within 1.8 m of another building on the same allotment are—
 - (i) fascias, gutters, downpipes and the like; and
 - (ii) eaves with *non-combustible* roof cladding and *non-combustible* lining; and
 - (iii) flues, chimneys, pipes, domestic fuel tanks, rainwater tanks, cooling or heating appliances or other services; and

- (iv) light fittings, electricity or gas meters, aerials or antennas; and
 - (v) pergolas or sun blinds; and
 - (vi) unroofed terraces, landings, steps and ramps, not more than 1 m in height.
- (c) Encroachments listed in **(b)(i)**, if *combustible*, **(b)(ii)** and **(b)(iii)** must not be built within 450 mm of an allotment boundary nor be built within 900 mm of the *external wall* or associated encroachments of another building on the same allotment. (see **Figure 3.7.1.9**)

Figure 3.7.1.9

ALLOWABLE ENCROACHMENTS FOR NON-COMBUSTIBLE CONSTRUCTION

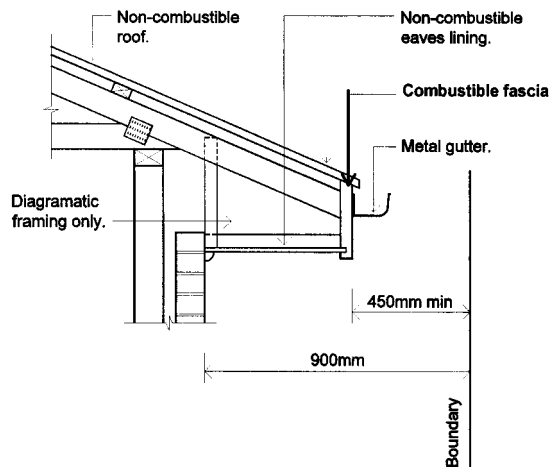

3.7.1.8 Separating walls

- (a) A wall that separates Class 1 dwellings, or separates a Class 1 building from a Class 10a building which is not appurtenant to that Class 1 building must have an FRL of not less than 60/60/60 and—
- (i) commence at the footings or ground slab (see **Figure 3.7.1.10**); and
 - (ii) extend—
 - (A) if the building has a *non-combustible* roof covering, to the underside of the roof covering (see **Figure 3.7.1.10** and **Figure 3.7.1.11**); or
 - (B) if the building has a *combustible* roof covering, to not less than 450 mm above the roof covering (see **Figure 3.7.1.10**).
- (b) A *separating wall of lightweight construction* must be tested in accordance with **Specification C1.8** of the BCA Volume One.

Figure 3.7.1.10

SEPARATING WALL CONSTRUCTION

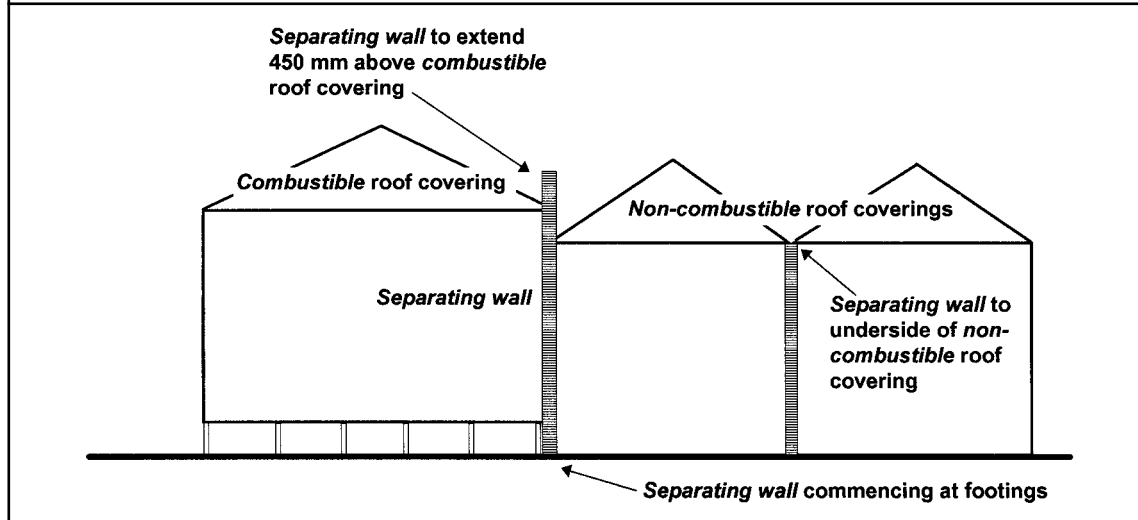

- (c) A separating wall complying with (a)(ii)(A)—
 - (i) must not be crossed by timber or other *combustible* building elements except for roof battens with dimensions of 75x50 mm or less, or roof sarking; and
 - (ii) must have any gap between the top of the wall and the underside of the roof covering packed with mineral fibre or other suitable *fire-resisting* material.
- (d) Where a building has a masonry veneer *external wall*, any gap between the *separating wall* and the external masonry veneer must be—
 - (i) not more than 50 mm; and
 - (ii) packed with a mineral fibre or other suitable *fire-resisting* material with the packing arranged to maintain any weatherproofing requirements of [Part 3.3.4](#).
- (e) Eaves, verandahs and similar spaces that are open to the roof space and are common to more than one Class 1 dwelling must be separated by a *non-combustible* vertical lining (see [Figure 3.7.1.11](#) Diagram b).

3.7.1.9 Fire hazard properties

The fire hazard properties of materials used in a Class 1 building, including common floor or ceiling spaces with a Class 10 building, must comply with the following:

- (a) *Sarking-type materials* used in the roof must have a *flammability index* not greater than 5.
- (b) Flexible ductwork used for the transfer of products initiating from a heat source that contains a flame must comply with the fire hazard properties set out in AS 4254.

3.7.1.10 Roof lights

Combustible roof lights, skylights or the like installed in a roof or part of a roof *required* to have a *non-combustible* covering must—

- (a) have an aggregate area not more than 20% of the roof or part of the roof; and
- (b) be not less than—

- (i) 900 mm from—
 - (A) the allotment boundary other than the boundary adjoining a road alignment or other public space; and
 - (B) the vertical projection of a *separating wall* extending to the underside of the roof covering; and
 - (ii) 1.8 m from any roof light or the like in another building on the allotment other than an appurtenant building or a detached part of the same building.
- (See [Figure 3.7.1.12](#))

Figure 3.7.1.11

SEPARATING WALL CONSTRUCTION—UNDERSIDE OF NON-COMBUSTIBLE ROOF CLADDING

Diagram a.

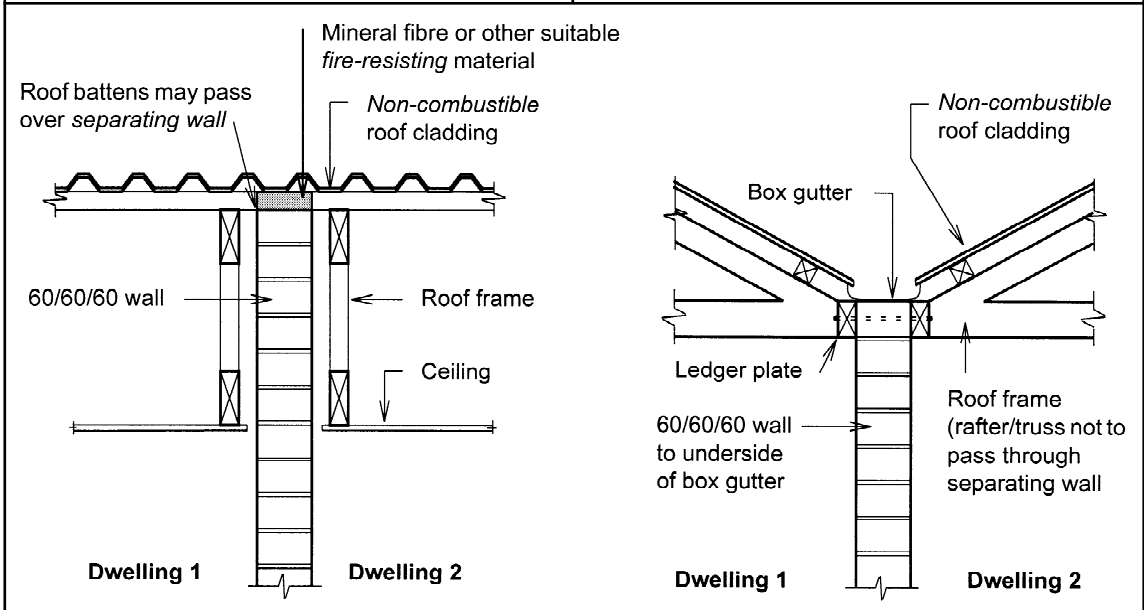

Figure 3.7.1.11

SEPARATING WALL CONSTRUCTION—UNDERSIDE OF NON-COMBUSTIBLE ROOF CLADDING

Diagram b.

OPTION 1 *Non-combustible* vertical lining installed between roof space of one Class 1 and the common eaves or verandah space

Elements crossing the *non-combustible* vertical lining must comply with Clause 3.7.1.8 (c)(i)

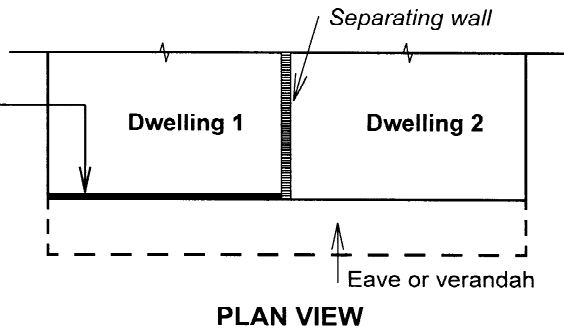

OPTION 2 *Non-combustible* vertical lining installed in common eaves or verandah space

Elements crossing the *non-combustible* vertical lining must comply with Clause 3.7.1.8 (c)(i)

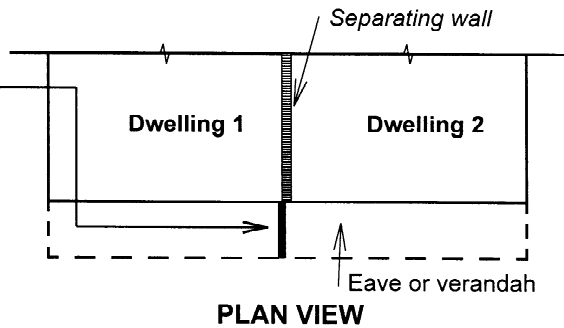

Note: The *Non-combustible* vertical lining need only be installed on one side of a rafter, truss or supporting framework, provided that it forms a continuous barrier with the *separating wall*

Figure 3.7.1.12

LOCATION OF COMBUSTIBLE ROOF LIGHTS

Note:

Roof lights depicted in Figure 3.7.1.12 are *combustible*.

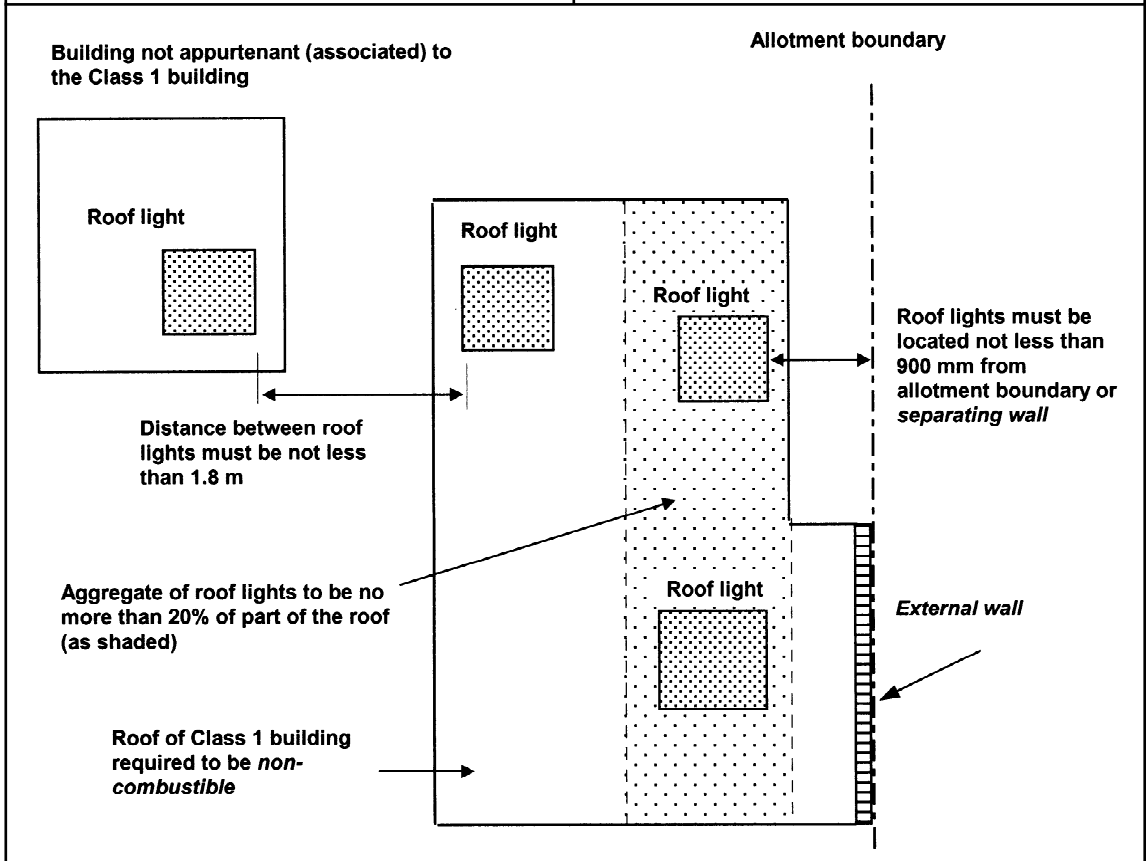

PART 3.7.2 SMOKE ALARMS

Appropriate Performance Requirements

Where an alternative smoke alarm system is proposed as an *Alternative Solution* to that described in Part 3.7.2, that proposal must comply with—

- (a) *Performance Requirement* **P2.3.2**; and
- (b) the relevant *Performance Requirements* determined in accordance with **1.0.10**.

Acceptable construction practice

3.7.2.1 Application

Compliance with this Part satisfies *Performance Requirement* **P2.3.2** for smoke alarms.

3.7.2.2 Requirements for smoke alarms

- (a) Smoke alarms must be installed in—
 - (i) Class 1a buildings in accordance with **3.7.2.3**; and
 - (ii) Class 1b buildings in accordance with **3.7.2.4** and **3.7.2.5**.
- (b) Smoke alarms must comply with AS 3786.
- (c) Smoke alarms must be connected to the consumer mains power where consumer power is supplied to the building.

3.7.2.3 Location—Class 1a buildings

Smoke alarms must be installed in a Class 1a building on or near the ceiling in—

- (a) any storey containing bedrooms—
 - (i) between each part of the dwelling containing bedrooms and the remainder of the dwelling; and
 - (ii) where bedrooms are served by a hallway, in that hallway, and
- (b) any other storey not containing bedrooms.
(see **Figure 3.7.2.1**, Diagram a and **Figure 3.7.2.2**)

3.7.2.4 Location—Class 1b buildings

In a Class 1b building, smoke alarms must be installed on or near the ceiling—

- (a) in every bedroom; and
- (b) in every corridor or hallway associated with a bedroom, or if there is no corridor or hallway, in an area between the bedrooms and the remainder of the building; and

(c) on each other storey.

(see [Figure 3.7.2.1](#), Diagram b and [Figure 3.7.2.2](#))

3.7.2.5 Lighting to assist evacuation—Class 1b buildings

In a Class 1b building, a system of lighting must be installed to assist evacuation of occupants in the event of a fire, and—

- (a) be activated by the smoke alarm *required by 3.7.2.4(b)*; and
- (b) consist of—
 - (i) a light incorporated within the smoke alarm; or
 - (ii) the lighting located in the corridor, hallway or area served by the smoke alarm.

Explanatory information:

The lighting required by [3.7.2.5](#) may consist of the artificial lighting which may already be installed in a corridor, hallway or area, provided that lighting is activated by the smoke alarm.

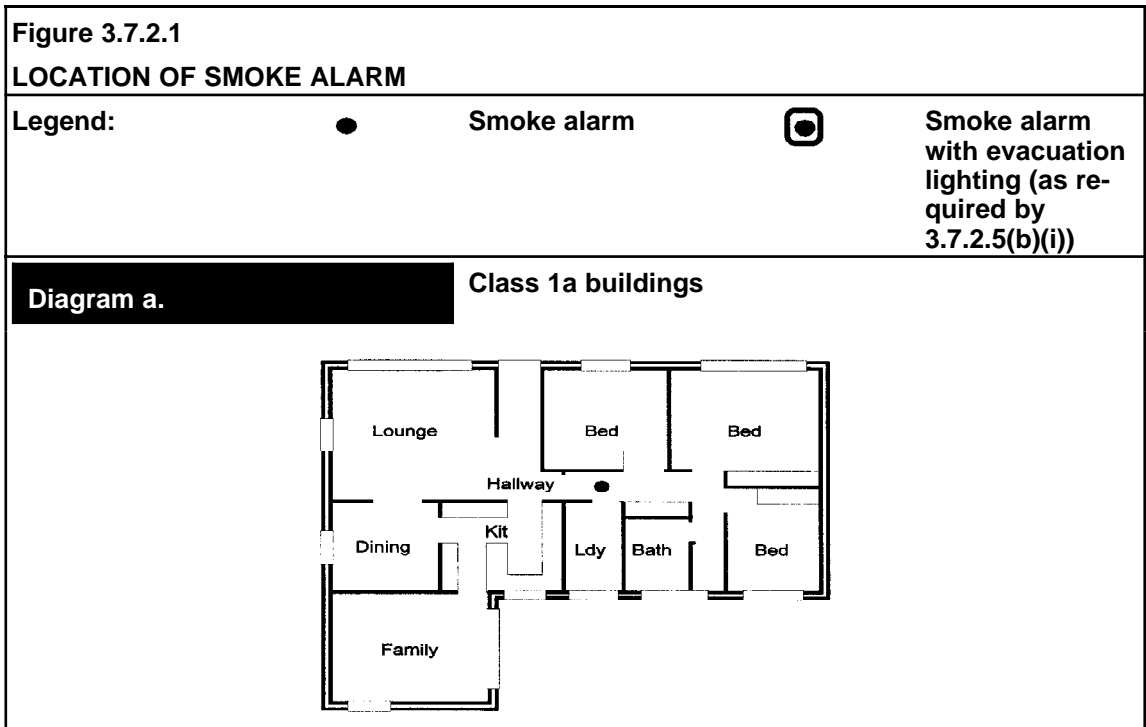

Figure 3.7.2.1

LOCATION OF SMOKE ALARM

Legend:	●	Smoke alarm	◻	Smoke alarm with evacuation lighting (as required by 3.7.2.5(b)(i))
----------------	---	-------------	---	---

Diagram b.

Class 1b buildings

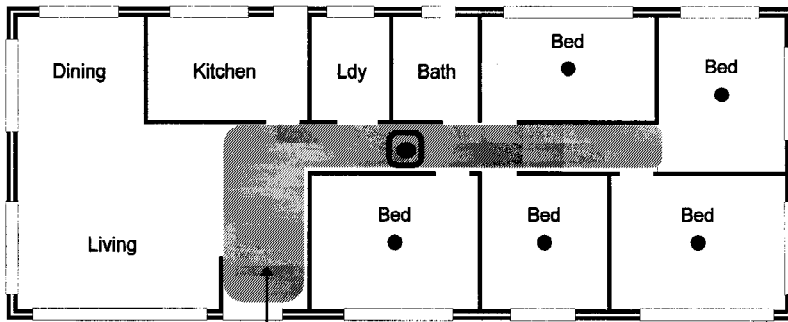

Lights in this area to be activated by smoke alarm if using 3.7.2.5(b)(ii).

Figure 3.7.2.2

LOCATION OF SMOKE ALARMS ON DIFFERENT STOREYS

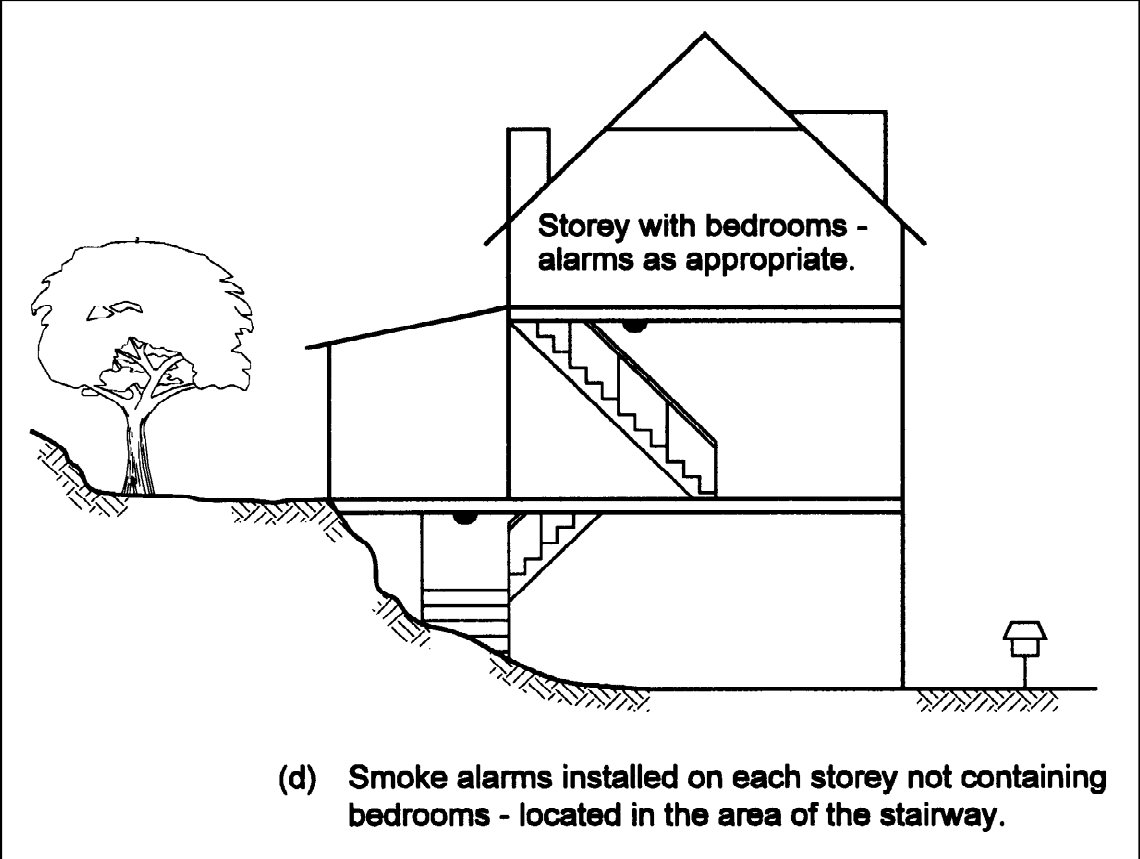

Explanatory information:

1. HOW DOES A SMOKE ALARM WORK ?

There are two types of smoke alarms.

1.1 Photoelectric:

This type of smoke alarm uses a light source and photocell. As the smoke enters the detection chamber it interferes with the light beam which in turn causes the alarm to sound.

1.2 Ionisation:

A small amount of radioactive material is used to create an electrical current which travels through ionised air. When smoke enters the detection chamber it impedes the flow of current and causes the alarm to sound.

2. LOCATION OF SMOKE ALARMS

When deciding on the position of smoke alarms it is important to remember that they are intended to detect smoke before it reaches the sleeping occupants of a building.

The ensuing alarm is designed to wake the occupants and give them time to evacuate the building.

2.1 Added flexibility when considering detector location

As mentioned earlier, the introduction of the *Performance Requirement* gives the *appropriate authority* flexibility when considering the location of smoke alarms.

For instance, in Class 1a buildings if the *Deemed-to-Satisfy Provision* states that the smoke alarm should be located in the hallway, and there is a bathroom adjacent this location (that will potentially cause nuisance alarms) the *appropriate authority* could accept the alarm being installed in the bedroom as a suitable option using the performance clause.

This approach should also be adopted when considering sleep-outs or similar type residential buildings that are not connected to the remainder of the building by a hallway or other enclosed structure. In these situations the alarm could be located in the room itself.

2.2 Protection of sleeping areas in Class 1a buildings

The deemed-to-satisfy provisions require that a smoke alarm be located “between each area containing bedrooms and the remainder of the dwelling”.

In some dwellings the bedrooms are located in a common area and connected by a hallway. In this instance the alarm should be located as shown in Figure 3.7.2.1, diagram a.

2.3 Location of the smoke alarm on other storeys

A smoke alarm is also required on each other storey that is not already provided with a smoke alarm. It should be noted that smoke alarms are required to be installed in other storeys even if those storeys consist of only carparking, bathrooms, laundries and the like. “Storey” in this context differs from the definition contained in BCA96 Volume One which excludes such spaces from being considered as storeys.

The favoured location for this alarm will be in the path of travel people will most likely take to evacuate the building. This will ensure an alarm will be raised before smoke makes the common exit path impassable.

eg If the bedrooms are on the first floor, then an alarm should be positioned near the area of the inter connecting stair at ground level.

If the other storey is not connected to the remainder of the building (for instance a ground floor garage) then the alarm should be centrally located in the lower area. However, it may be reasonable, using a performance approach, not to install smoke alarms where the storey is predominantly open, such as the basement level of a highset house on stumps that is used for carparking or laundry purposes.

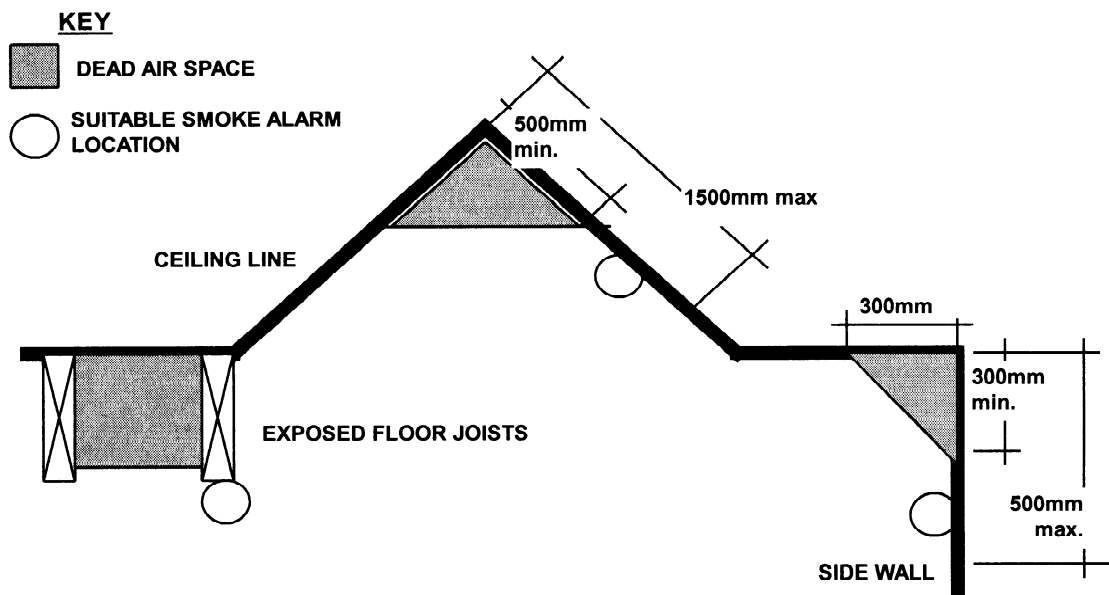

DIAGRAM 1 - DEAD AIR SPACE AND PROPER MOUNTING OF SMOKE ALARMS ON SIDE WALLS

2.4 Installation of smoke alarms

Smoke alarms should be installed on or near the ceiling with special care being taken to avoid dead air spaces.

A dead air space is an area in which trapped hot air will prevent smoke from reaching the alarm. This space generally occurs at the apex of cathedral ceilings, the corner junction of walls and ceilings, between exposed floor joists etc (see Diagram 1).

If it is impractical to mount the smoke alarm on the ceiling then it may be located on the wall. The recommended position is between 300 mm and 500 mm off the ceiling (see Diagram 1).

The distance from the apex of a cathedral ceiling to the top of the alarm should be between 500 mm and 1500 mm.

3. NUISANCE ALARMS

Smoke alarms are extremely sensitive and may detect smoke and moisture created by common household activities (such as burnt toast or steam from a bathroom).

Accordingly, to reduce the likelihood of nuisance alarms, the smoke alarm should not be located near cooking appliances and bathrooms. However, if it is necessary to locate alarms in these positions, an ionisation type alarm is more suitable near bathrooms, while a photoelectric alarm may be used near cooking appliances.

4. INTERCONNECTION OF SMOKE ALARMS

SUPERSEDED
FIRE SAFETY

Some types of alarm are capable of interconnection to the other alarms so that if one alarm sounds then the other alarms are also activated adding an enhanced level of safety. There is no requirement in the BCA that smoke alarms be interconnected.

PART 3.7.3 HEATING APPLIANCES

Appropriate Performance Requirements

Where an alternative heating appliance is proposed as an *Alternative Solution* to that described in Part 3.7.3, that proposal must comply with—

- (a) *Performance Requirement* **P2.3.3**; and
- (b) the relevant *Performance Requirements* determined in accordance with **1.0.10**.

A. Acceptable construction manuals

3.7.3.0

Performance Requirement **P2.3.3** is satisfied for a heating appliance if it is installed in accordance with one of the following manuals:

- (a) Domestic oil-fired appliances are installed in accordance with AS 1691.
- (b) Domestic solid-fuel burning appliances are installed in accordance with AS/NZS 2918.
- (c) Boilers and pressure vessels are installed in accordance with AS/NZS 1200.

B. Acceptable construction practice

3.7.3.1 Application

Compliance with this Part satisfies *Performance Requirement* **P2.3.3** for heating appliances.

3.7.3.2 Open fireplace construction

An open fireplace must be constructed as follows (also see **Figure 3.7.3.1**):

- (a) All masonry must be constructed in accordance with **Part 3.3**.
- (b) The front hearth must be constructed of stone, concrete, masonry or similar material so that—
 - (i) it extends not less than 300 mm beyond the front of the fireplace opening and not less than 150 mm beyond each side of that opening; and
 - (ii) its upper surface does not slope away from the back hearth.
- (c) The base of the back hearth must be constructed of stone, concrete, masonry or similar material and any *combustible* flooring or framing members must be situated not less than 150 mm from its upper surface.

-
- (d) The fireplace rear and side walls up to a height of 300 mm above the underside of the arch or lintel—
- (i) must be constructed in 2 separate leaves of solid masonry with an overall thickness not less than 180 mm thick, excluding any *cavity*; and
 - (ii) must not consist of concrete block masonry in the construction of the inner leaf; and
 - (iii) must be constructed of masonry units with a net volume, excluding cored and similar holes, not less than 75% of their gross volume, measured on the overall rectangular shape of the units, and with an actual thickness of not less than 100 mm.
- (e) The fireplace must be constructed on footings complying with [3.2.5.5](#).

Figure 3.7.3.1

FIRE PLACE CLEARANCE FROM COMBUSTIBLE MATERIALS

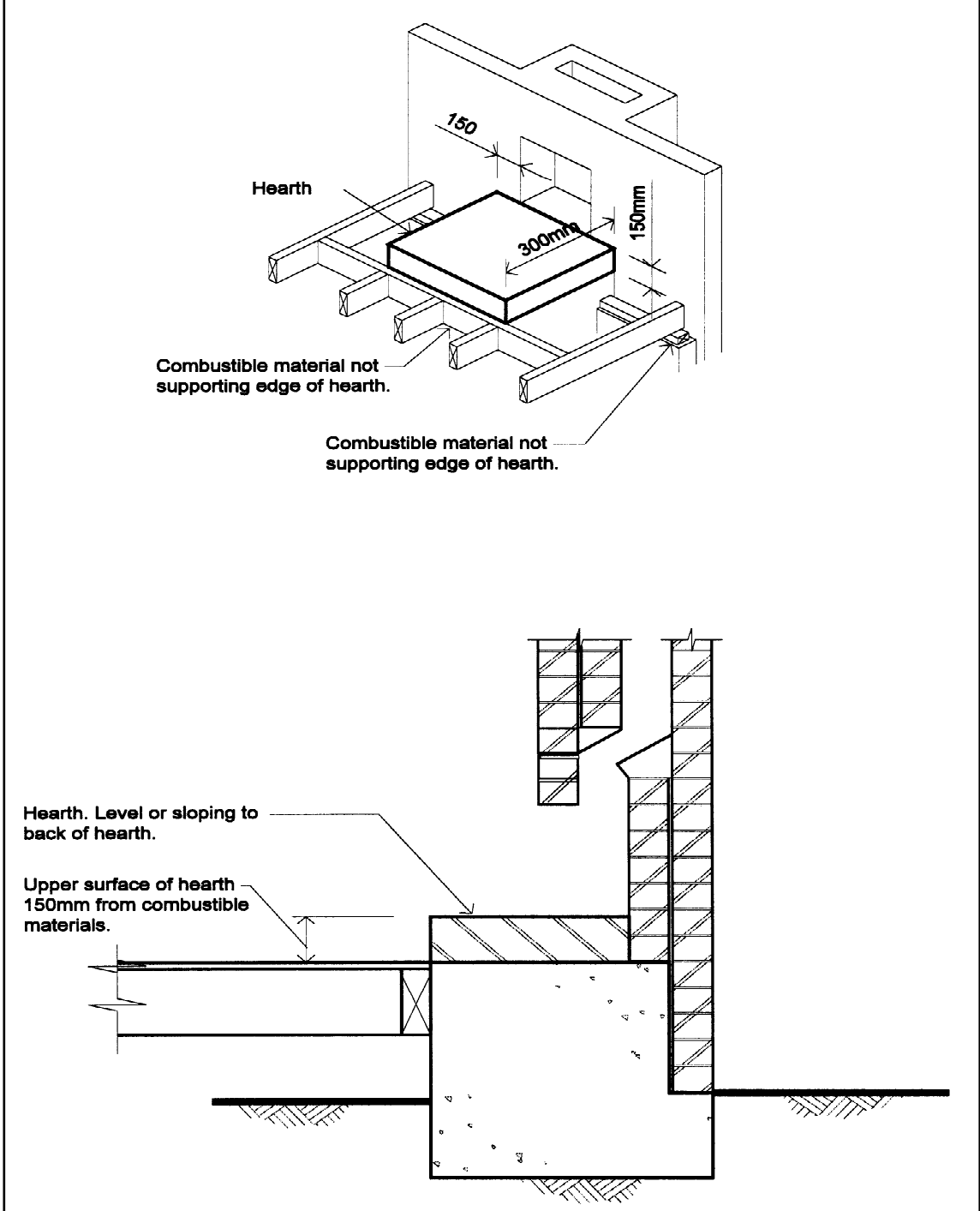

3.7.3.3 Chimney construction

The construction of a chimney must comply with [Part 3.3](#) and the following:

- (a) The walls of the chimney above the level referred to in [3.7.3.2\(d\)](#) must be lined internally to a thickness of not less than 10 mm with composition mortar parging.
- (b) The chimney or flue must terminate not less than 300 mm above the highest part of the building within a horizontal distance of 3.6 m of the chimney or flue (see [Figure 3.7.3.2](#)).

Explanatory information:

The requirements of this Part are to be read in conjunction with the building sealing requirements in [Part 3.12.3](#). However, it should be noted that [Part 3.12.3](#) does not apply in Australian Capital Territory, New South Wales, Queensland, Victoria and Western Australia.

Figure 3.7.3.2

SECTION SHOWING HEIGHT AND POSITION OF CHIMNEY

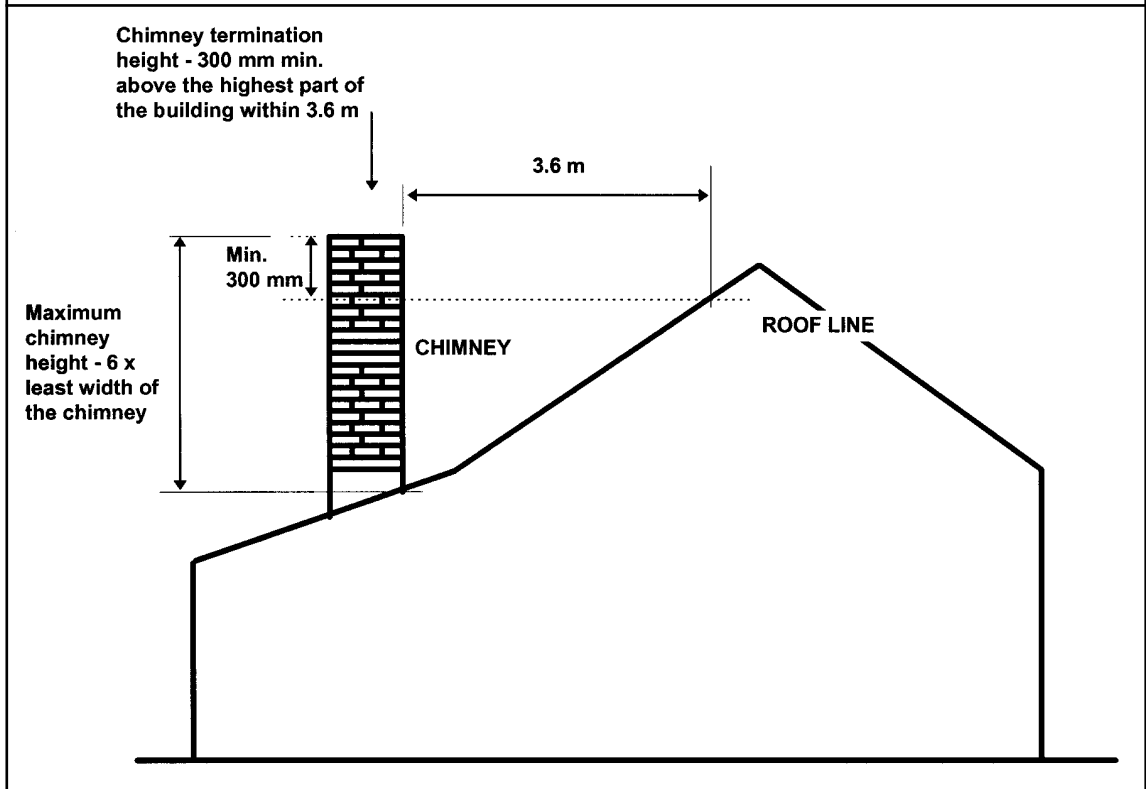

3.7.3.4 Installation of insert fireplaces and flues

An insert fireplace and flue must comply with the following:

- (a) The insert fireplace must be tested and passed the tests required by AS/NZS 2918.
- (b) The insert fireplace must be fitted into a masonry fireplace (including chimney) constructed in accordance with [Part 3.3](#).

- (c) The flue must be—
- (i) double skin and have been tested and pass the tests required by AS/NZS 2918; or
 - (ii) cast iron, cellulose fibre reinforced cement not less than 9.5 mm thick, galvanised steel not less than 1.2 mm thick or such other material of at least equivalent strength and durability, installed in accordance with Section 6 of AS 1691, as though it is a flue connected to an oil heating appliance.

Figure 3.7.3.3
TYPICAL INSTALLATION OF FIRE PLACE FLUE INSERTS

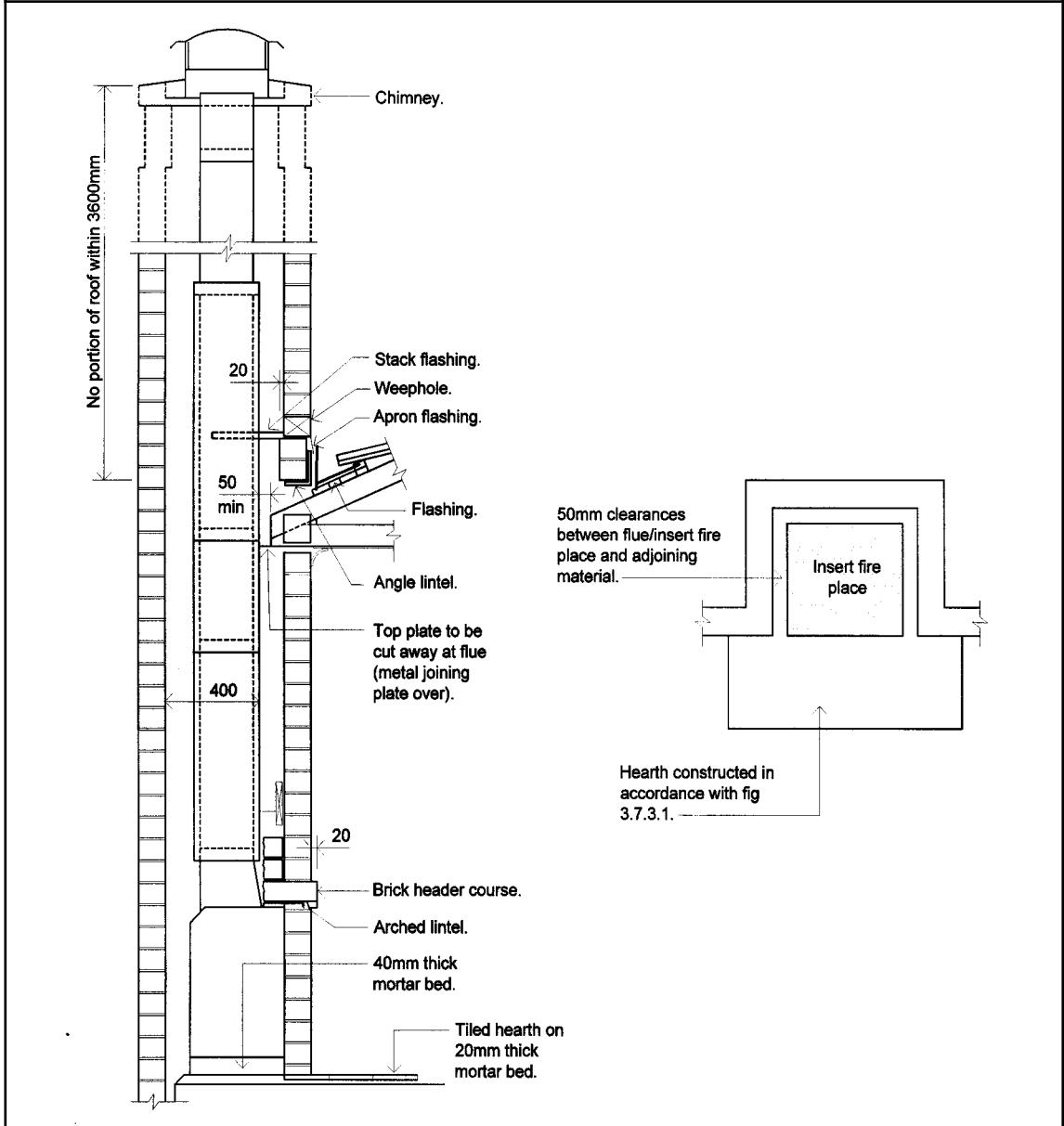

- (d) There must be a clearance of 50 mm between the outer flue and adjacent materials.

- (e) The flue must terminate in accordance with [Figure 3.7.3.2](#).
- (f) The hearth must be constructed in accordance with [3.7.3.2\(b\)](#), [\(c\)](#) and [\(e\)](#).

3.7.3.5 Installation of free standing heating appliances

The installation of a free standing heating appliance must comply with the following:

- (a) The appliance must—
 - (i) be installed with safety clearances determined by testing in accordance with AS/NZS 2918; or
 - (ii) be located not less than 1.2 m from adjoining walls (other than a masonry wall); or
 - (iii) have a heat shield between the adjoining wall (other than a masonry wall) and the heating appliance in accordance with [Figure 3.7.3.4](#).
- (b) Where a heat shield is used, it must be installed in accordance with [Figure 3.7.3.4](#) and it must be not less than 90 mm thick masonry constructed in accordance with [Part 3.3](#).
- (c) The heating appliance must be installed on a hearth—
 - (i) complying with [3.7.3.2\(b\)](#) and [\(c\)](#), except that the hearth must extend 400 mm from the appliance in accordance with [Figure 3.7.3.4](#); or
 - (ii) where a heat shield is installed, in accordance with [Figure 3.7.3.4](#).
- (d) The flue must—
 - (i) have been tested and passed the tests required by AS/NZS 2918; and
 - (ii) be installed in accordance with [Figure 3.7.3.5](#); and
 - (iii) terminate in accordance with [Figure 3.7.3.2](#).
- (e) Flue types or installation of flues in areas not specifically covered by [Figures 3.7.3.4](#) and [3.7.3.5](#) must be installed in accordance with AS/NZS 2918.

Figure 3.7.3.4

ACCEPTABLE LOCATION OF FREE STANDING HEATING APPLIANCES

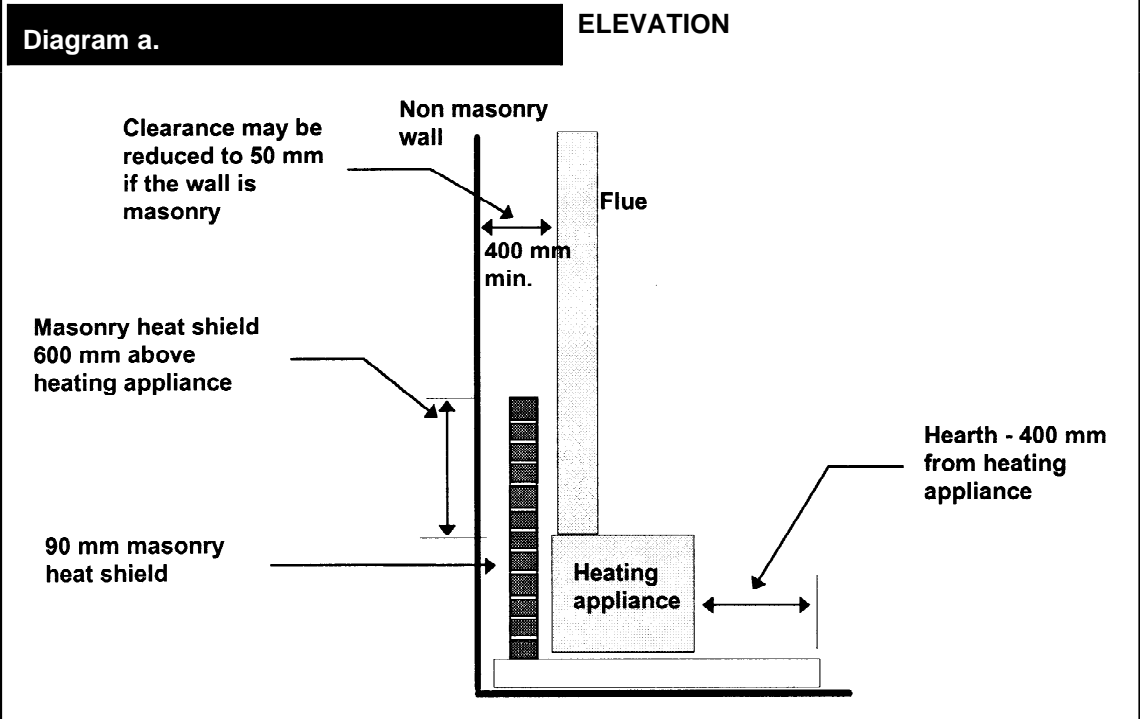
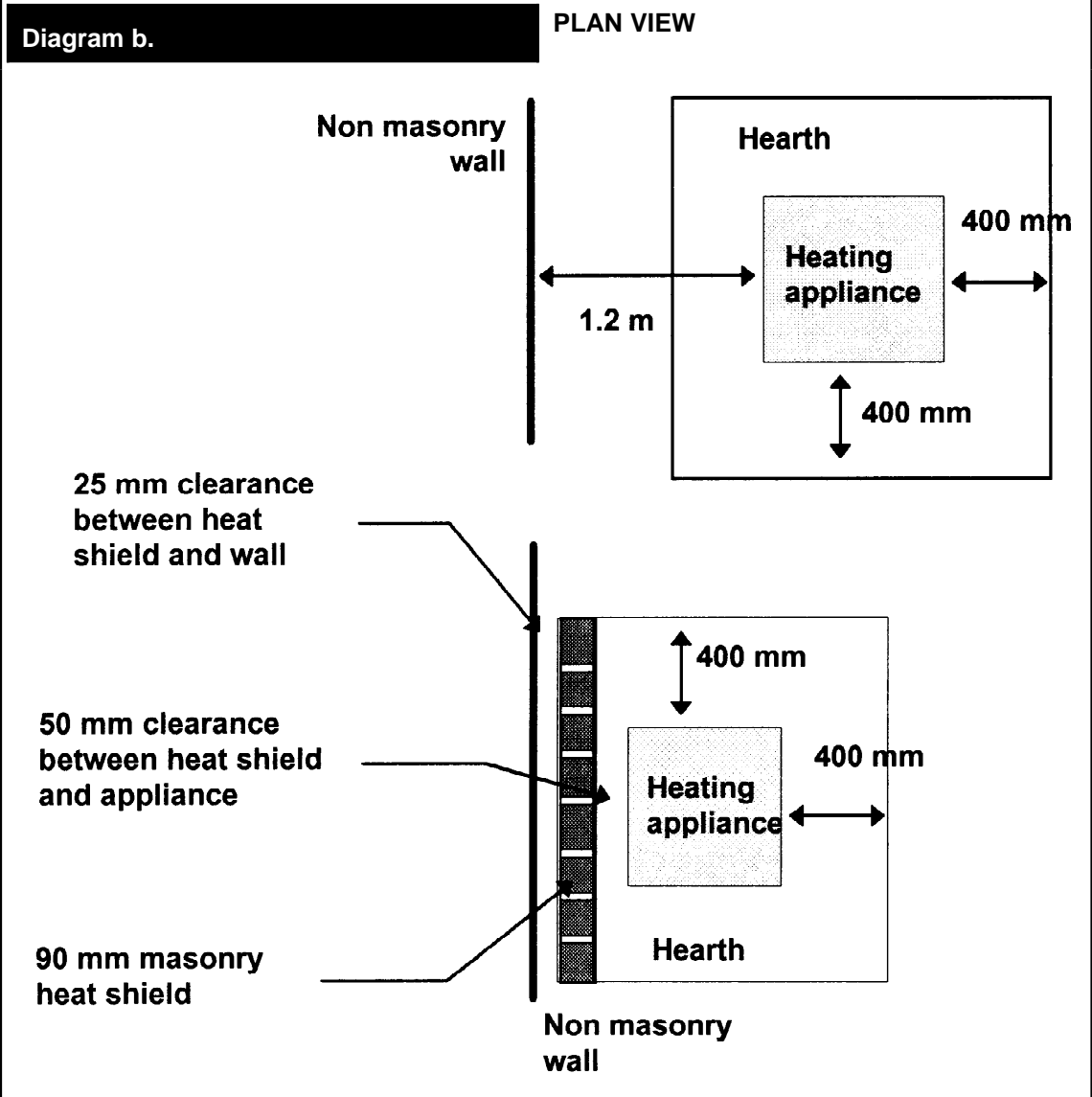

Figure 3.7.3.4

ACCEPTABLE LOCATION OF FREE STANDING HEATING APPLIANCES



**Figure 3.7.3.5
ACCEPTABLE FLUE INSTALLATION DETAILS**

Note: Flue pipe size—150 mm maximum (for other sizes see AS/NZS 2918)

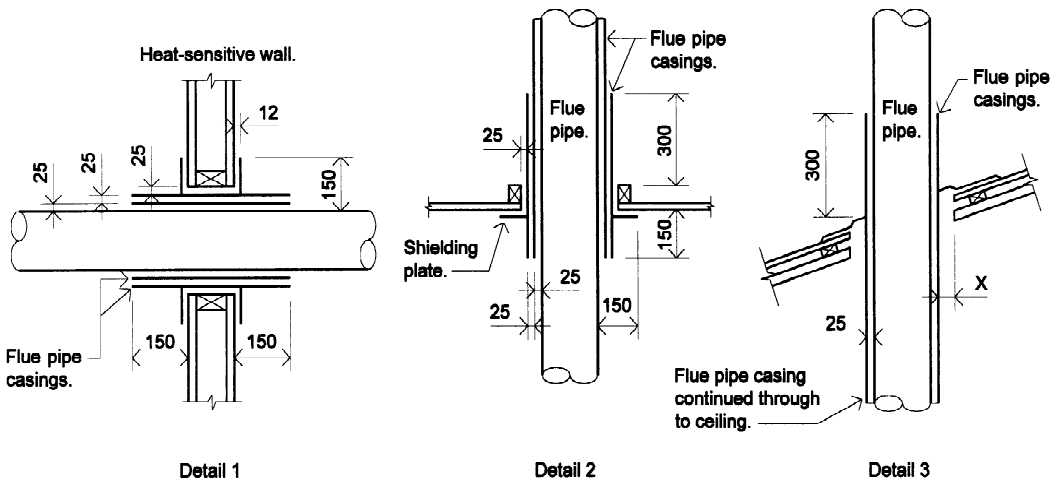
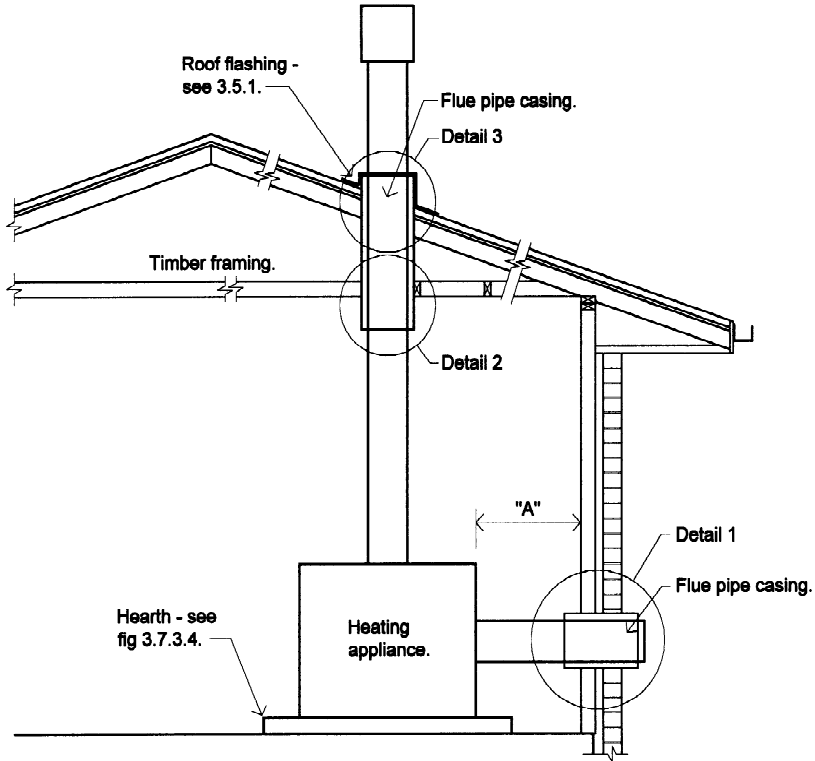

PART 3.7.4 BUSHFIRE AREAS

Appropriate Performance Requirements

Where an alternative bushfire protection design is proposed as an *Alternative Solution* to that described in Part 3.7.4, that proposal must comply with—

- (a) Performance Requirement **P2.3.4**; and
- (b) the relevant *Performance Requirements* determined in accordance with **1.0.10**.

A. Acceptable construction manuals

3.7.4.0

Performance Requirement **P2.3.4** is satisfied for a Class 1 building located in a *designated bushfire prone area* if it is constructed in accordance with AS 3959—Construction of buildings in bushfire prone areas.

STATE AND TERRITORY VARIATIONS

In New South Wales 3.7.4.0 is replaced with the following:

Performance Requirement **P2.3.4** is satisfied for a Class 1 building located in a *designated bushfire prone area* if it is constructed in accordance with the following—

- (a) AS 3959—Construction of buildings in bushfire prone areas, excluding Section 2 “Site Bushfire Attack Assessment”, which is replaced by Planning for Bushfire Protection, Appendix 3 “Site Assessment for Bushfire Attack”; or
- (b) subclause (a) as modified by the development consent following consultation with NSW Rural Fire Service under section 79BA of the Environmental Planning and Assessment Act 1979; or
- (c) subclause (a) as modified for the development consent with a bushfire safety authority issued under section 100B of the Rural Fires Act 1997 for the purposes of integrated development.

STATE AND TERRITORY VARIATIONS

3.7.4.0 is replaced by the following clause in South Australia:

Performance Requirement **P2.3.4** is satisfied for a Class 1 building located in a *designated bushfire prone area* as defined under relevant State and Territory legislation, if it is constructed in accordance with AS 3959 with the following variation—

The requirement to use fire retardant treated timber is varied to allow hardwood timber (as defined in AS 1720.2) with a minimum density at 12% moisture content of 650 kg/m³ in lieu of fire retardant treated timber.

The following additional bushfire protection shall be provided in medium, high and extreme attack categories (as determined from AS 3959) as follows:

- (a) A framed floor, the underside of which is greater than 600 mm above ground level shall have the sub-floor space completely protected by—
 - (i) a wall complying with AS 3959; or
 - (ii) a *non-combustible* sheet material; or
 - (iii) a vertical *non-combustible* sheet material that extends around the perimeter of the floor from the underside of the lowest framing member to ground level; and
 - (iv) if fibre-reinforced sheets are used as a *non-combustible* sheet material they must have a minimum thickness of 6 mm.
- (b) Wall cladding of *non-combustible* material or fire-retardant timber shall be provided within 400 mm of finished ground level, paving level or any balcony or deck with solid flooring.
- (c) Penetrations through the roof cladding for vent pipes and the like shall be sealed with a *non-combustible* collar or fire-retardant sealant.
- (d) Where a garage, carport, verandah or similar structure is attached to or shares a common roof space with a building *required* to comply with AS 3959, it must also comply with AS 3959.

B. Acceptable construction practice

3.7.4.1 Application

Compliance with this Part for Class 1 buildings constructed in a *designated bushfire prone area* satisfies *Performance Requirement P2.3.4*.

STATE AND TERRITORY VARIATIONS

3.7.4.1 is replaced by the following clause in South Australia:

Compliance with this Part, and the following, for Class 1 buildings constructed in a *designated bushfire prone area* satisfies *Performance Requirement P2.3.4*:

The requirement to use fire retardant treated timber is varied to allow hardwood timber (as defined in AS 1720.2) with a minimum density at 12% moisture content of 650 kg/m³ in lieu of fire retardant treated timber.

The following additional bushfire protection shall be provided in medium, high and extreme attack categories (as determined from AS 3959) as follows:

- (a) A framed floor, the underside of which is greater than 600 mm above ground level shall have the sub-floor space completely protected by—
 - (i) a wall complying with AS 3959; or
 - (ii) a *non-combustible* sheet material; or
 - (iii) a vertical *non-combustible* sheet material that extends around the perimeter of the floor from the underside of the lowest framing member to ground level; and

- (iv) if fibre-reinforced sheets are used as a *non-combustible* sheet material they must have a minimum thickness of 6 mm.
- (b) Wall cladding of *non-combustible* material or fire-retardant timber shall be provided within 400 mm of finished ground level, paving level or any balcony or deck with solid flooring.
- (c) Penetrations through the roof cladding for vent pipes and the like shall be sealed with a *non-combustible* collar or fire-retardant sealant.
- (d) Where a garage, carport, verandah or similar structure is attached to or shares a common roof space with a building *required* to comply with AS 3959, it must also comply with AS 3959.

3.7.4.2 Categories of bushfire attack

The category of bushfire attack for a *site* must be determined in accordance with AS 3959.

Explanatory information:

AS 3959 contains a methodology for assessment of the category of bushfire attack for a *site*. The categories are determined by considering the predominant vegetation type, the distance between the *site* and the predominant vegetation, and the average slope of the land between the *site* and the predominant vegetation. The categories of bushfire attack are low, medium, high and extreme.

For the category of low bushfire attack, the degree of bushfire attack is considered insufficient to warrant specific construction requirements.

STATE AND TERRITORY VARIATIONS

3.7.4.2 in New South Wales is replaced with the following:

The category of bushfire attack for a *site* must be determined in accordance with Planning for Bushfire Protection, Appendix 3 “Site Assessment for Bushfire Attack”; except—

- (a) as modified by the development consent following consultation with the NSW Rural Fire Service under section 79BA of the Environmental Planning and Assessment Act 1979; or
- (c) as modified for the development consent with a bush fire safety authority issued under section 100B of the Rural Fires Act 1997 for the purposes of integrated development.

3.7.4.3 Construction requirements

- (a) A Class 1 building must be constructed using the acceptable methods listed in [Table 3.7.4.1](#) for the category of bushfire attack for the *site*.
- (b) For the purposes of [Part 3.7.4](#), fire-retardant-treated timber is timber that has been tested to AS/NZS 3837 and meets the following parameters after having been subjected to the regime of ASTM D2898 Method B:
 - (i) Ignition does not occur when the material is exposed to an irradiance level of 10 kW/m².

- (ii) The maximum heat release rate is not greater than 100 kW/m² and the average heat release rate for 10 minutes following ignition is not greater than 60 kW/m² when the material is exposed to an irradiance level of 25 kW/m².
- (c) Where the timber is protected from the weather as described in Appendix C of AS 1684.2 and AS 1684.3, the timber need not be subjected to the regime of ASTM D2898 Method B before being tested to AS/NZS 3837.

Explanatory information:

External timbers are regarded as protected if they are covered by a roof (or similar structure) at 30° or greater to the vertical (see [Figure 3.7.4.5](#)) and they are well detailed and maintained (ie painted or stained and kept well ventilated).

Some timbers used in building construction may be capable of meeting the parameters identified in [3.7.4.3\(b\)](#) without having to be subjected to fire retardant treatment.

STATE AND TERRITORY VARIATIONS

Add subclause (d) New South Wales as follows:

- (d) Subclauses (a), (b) and (c) may be modified—
 - (i) by the development consent following consultation with the NSW Rural Fire Service under section 79BA of the Environmental Planning and Assessment Act 1979; or
 - (ii) for development consent with a bush fire safety authority issued under section 100B of the Rural Fires Act 1997 for the purposes of integrated development.

Table 3.7.4.1 CONSTRUCTION FOR MEDIUM, HIGH AND EXTREME CATEGORIES OF BUSHFIRE ATTACK

FLOORING SYSTEMS	
1.	Medium bushfire attack category
(a)	Concrete slab on ground.
(b)	Suspended concrete floor.
(c)	Framed floor with all joists and/or bearers not less than 600 mm above finished ground level.
(d)	Framed floor where any joist and/or bearer is less than 600 mm above finished ground level, where—
(i)	any timber bearers, joists or flooring are of fire-retardant-treated timber; or
(ii)	the sub-floor space is fully enclosed with a wall complying with the requirements of this table for an <i>external wall</i> ; or
(iii)	the sub-floor space is fully enclosed with <i>non-combustible</i> sheet material that extends not less than 400 mm above finished ground level and to the bottom of the wall cladding material. If fibre-reinforced cement sheets are used for this purpose, the sheets must have a minimum thickness of 6 mm (see Figure 3.7.4.1).
2.	High bushfire attack category
As per requirements for category of medium bushfire attack.	

3.	Extreme bushfire attack category
As per requirements for category of medium bushfire attack except that, in the case of a framed floor, where any bearer or joist is greater than 600 mm above finished ground level and the floor is not enclosed, the bearer, joists and flooring must be fire-retardant-treated timber or sheeted underneath with <i>non-combustible</i> material.	
SUPPORTING POSTS, COLUMNS, STUMPS, PIERS AND POLES (except in sub-floor spaces enclosed by one of the methods described in FLOORING SYSTEMS 1(d)(iii))	
1.	Medium bushfire attack category
(a)	<i>Non-combustible</i> material.
(b)	Fire-retardant-treated timber for not less than 400 mm above <i>finished ground level</i> .
(c)	Timber mounted on metal stirrups with a clearance of not less than 75 mm above finished ground or paving level (see Figure 3.7.4.2).
2.	High bushfire attack category
As per requirements for category of medium bushfire attack.	
3.	Extreme bushfire attack category
As per requirements for category of medium bushfire attack except that all timber shall be fire-retardant-treated timber.	
EXTERNAL WALLS	
1.	Medium bushfire attack category
(a)	Masonry, concrete or earthwall construction for the external leaf.
(b)	Framed wall with—
(i)	sarking having a <i>Flammability Index</i> of not more than 5; or
(ii)	an insulation material conforming with the appropriate standard for that material.
(c)	Timber logs with all joints between the logs gauge-planed and sealed.
(d)	<i>Combustible</i> sheet cladding provided that the cladding within 400 mm of the finished ground or paving level is covered by, or substituted with—
(i)	<i>non-combustible</i> sheet material; or
(ii)	fire-retardant-treated timber.
2.	High bushfire attack category
As per requirements for category of medium bushfire attack, except that—	
(a)	PVC cladding must not be used; and
(b)	timber wall cladding must be of fire-retardant-treated timber.
3.	Extreme bushfire attack category
As per requirements for category of high bushfire attack.	

WINDOWS	
1.	Medium bushfire attack category
The openable part of a <i>window</i> , including louvres, must be screened with corrosion-resistant steel, bronze or aluminium mesh with a maximum aperture size of 1.8 mm.	
2.	High bushfire attack category
As per requirements for category of medium bushfire attack, except that—	
(a)	where timber is used, it must be fire-retardant-treated timber, except where protected by <i>non-combustible</i> shutters; and
(b)	where leadlight <i>windows</i> are used, they must be protected by shutters made of <i>non-combustible</i> material or of toughened glass.
(c)	aluminium mesh must not be used in the <i>window</i> screens.
3.	Extreme bushfire attack category
As per requirements for category of high bushfire attack except that if the windows are not protected by non-combustible shutters, they shall be glazed with toughened glass.	
EXTERNAL DOORS	
1.	Medium bushfire attack category
External doors must be fitted with—	
(a)	weather strips or draught excluders to prevent the build-up of burning debris beneath the door; and
(b)	tight-fitting screen doors with corrosion-resistant steel, bronze or aluminium mesh with a maximum aperture size of 1.8 mm.
2.	High bushfire attack category
As per requirements for category of medium bushfire attack, except that—	
(a)	aluminium mesh must not be used in the screen door; and
(b)	if leadlight glazing panels are used in the door, they must be protected by shutters made from <i>non-combustible</i> material or of toughened glass.
3.	Extreme bushfire attack category
As per requirements for category of high bushfire attack, except that—	
(a)	timber doors must be fire-retardant-treated timber or have a <i>non-combustible</i> covering on the exterior surface; or
(b)	doors must be protected by <i>non-combustible</i> shutters; or
(c)	doors must be solid-core having a minimum thickness of 35 mm.
VENTS AND WEEPHOLES	
1.	Medium bushfire attack category
Vents and weepholes must be protected with spark guards made from corrosion-resistant steel, bronze or aluminium mesh with a maximum aperture size of 1.8 mm.	

2.	High bushfire attack category
As per requirements for category of medium bushfire attack, except that aluminium mesh must not be used in the spark guards.	
3.	Extreme bushfire attack category
As per requirements for category of high bushfire attack.	
ROOF COVERING, EAVES AND FASCIAS	
1.	Medium bushfire attack category
(a)	Timber shakes or shingles must not be used for the roof covering.
(b)	Sheet roofing must be metal or fibre-reinforced cement.
(c)	Gaps under corrugations or ribs of sheet roofing must be sealed or protected at the wall or fascia line by—
(i)	fully sarking the roof; or
(ii)	providing corrosion-resistant steel or bronze mesh with a maximum aperture size of 1.8 mm, profiled metal sheet, neoprene seal or compressed mineral wool.
(d)	Rib caps and ridge capping on sheet roofing must be preformed or the gaps between the capping and the sheeting sealed or protected in accordance with (c).
(e)	The roof/wall junction must be sealed by—
(i)	the use of fascia and eaves lining; or
(ii)	sealing the gaps between the rafters at the line of the wall with a <i>non-combustible</i> material (see Figure 3.7.4.3).
(f)	Tiled roofs must be fully sarked, including the ridge, and the sarking must be located directly beneath the tiling battens.
(g)	Any sarking used in the roof must have a <i>Flammability Index</i> of not more than 5.
2.	High bushfire attack category
As per requirements for category of medium bushfire attack, except that—	
(a)	all roof sheeting must be <i>non-combustible</i> and sarked; and
(b)	timber eaves lining and joining strips must be of fire-retardant-treated timber (see Figure 3.7.4.3); and
(c)	fascias must be <i>non-combustible</i> or of fire-retardant-treated timber (see Figure 3.7.4.3).
3.	Extreme bushfire attack category
As per requirements for category of high bushfire attack, except that—	
(a)	fibre-reinforced cement or aluminium sheet must not be used for roof sheeting or fascias; and
(b)	aluminium must not be used for eaves linings.
ROOF LIGHTS	
1.	Medium bushfire attack category
(a)	Roof light penetrations and associated shafts through the roof space must be sealed with a <i>non-combustible</i> sleeve or lining (see Figure 3.7.4.4).

(b)	A roof light may consist of thermoplastic sheet in a metal frame, provided that the diffuser at ceiling level is of wired or toughened glass in a metal frame.
-----	--

(c)	Openings in ventilated roof lights must be provided with corrosion-resistant steel or bronze mesh having a maximum aperture size of 1.8 mm.
-----	---

2.	High bushfire attack category
-----------	--------------------------------------

As per requirements for category of medium bushfire attack, except that roof light glazing must be of wired glass. Thermoplastic material or toughened glass must not be used.

3.	Extreme bushfire attack category
-----------	---

As per requirements for category of high bushfire attack.

ROOF VENTILATORS	
-------------------------	--

1.	Medium bushfire attack category
-----------	--

All components of roof ventilators, including rotary ventilators, must be of *non-combustible* material and have ventilation openings protected by corrosion-resistant steel or bronze mesh having a maximum aperture size of 1.8 mm.

2.	High bushfire attack category
-----------	--------------------------------------

As per requirements for category of medium bushfire attack.

3.	Extreme bushfire attack category
-----------	---

As per requirements for category of medium bushfire attack.

ROOF-MOUNTED EVAPORATIVE COOLING UNITS	
---	--

1.	Medium bushfire attack category
-----------	--

All openings into the cooling unit must be protected by corrosion-resistant steel or bronze mesh with a maximum aperture size of 1.8 mm.

2.	High bushfire attack category
-----------	--------------------------------------

As per requirements for category of medium bushfire attack, except that the outer case of the evaporative cooling unit must be of *non-combustible* material.

3.	Extreme bushfire attack category
-----------	---

As per requirements for category of high bushfire attack.

GUTTERS AND DOWNPIPES	
------------------------------	--

1.	Medium bushfire attack category
-----------	--

Materials or devices used to stop leaves collecting in gutters must have a *Flammability Index* of not more than 5.

2.	High bushfire attack category
-----------	--------------------------------------

As per requirements for category of medium bushfire attack.

3.	Extreme bushfire attack category
-----------	---

As per requirements for category of medium bushfire attack.

SERVICE PIPES (water and gas)	
1.	Medium bushfire attack category
Piping for water and gas supplies must—	
(a)	be buried to a depth of not less than 300 mm below finished ground level; or
(b)	be of metal.
2.	High bushfire attack category
As per requirements for category of medium bushfire attack.	
3.	Extreme bushfire attack category
As per requirements for category of medium bushfire attack.	
VERANDAHS AND DECKS	
1.	Medium bushfire attack category
(a)	Slab on ground or suspended concrete slab.
(b)	Any supporting posts or columns must comply with the requirements of this table for supporting posts, columns stumps, piers and poles.
(c)	Any supporting walls must comply with the requirements of this table for <i>external walls</i> .
(d)	Where sheeted or tongue and grooved solid flooring is used, the flooring system must comply with the requirements of this table for flooring systems.
(e)	Where spaced timber deck flooring is used—
(i)	the gap between the timber deck flooring must be not less than 5 mm; and
(ii)	to facilitate access for extinguishment, the perimeter of the area beneath the deck must not be enclosed or access to the space beneath the deck impeded; and
(iii)	the timber deck flooring must be separated from the remainder of the building in a manner that will not spread fire into the building.
2.	High bushfire attack category
As per requirements for category of medium bushfire attack, except that if spaced timber deck flooring is used, fire-retardant-treated timber must be used for the decking material.	
3.	Extreme bushfire attack category
As per requirements for category of high bushfire attack, except that all materials (including any balustrades) must be <i>non-combustible</i> or if timber is used, it must be fire-retardant-treated.	

Figure 3.7.4.1

PROTECTION OF SUB-FLOOR SPACES WITH LESS THAN 600 MM CLEARANCE

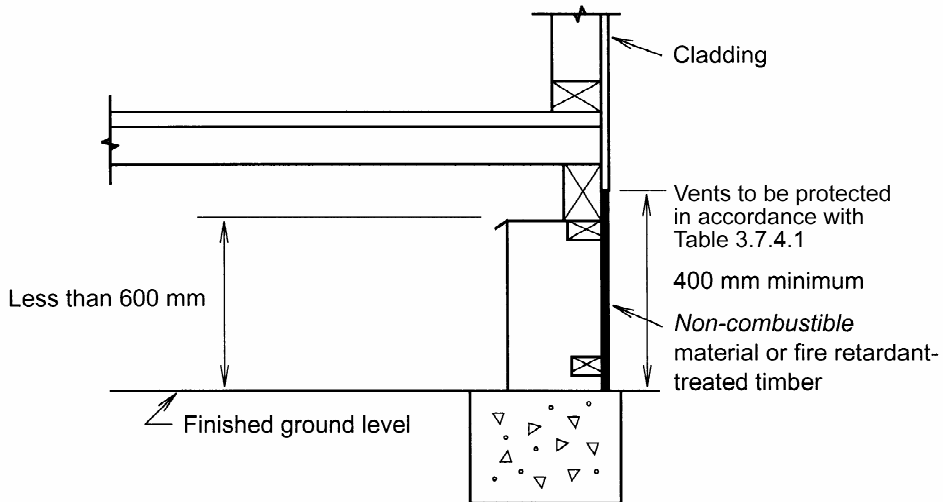

Figure 3.7.4.2

METAL STIRRUP CLEARANCE

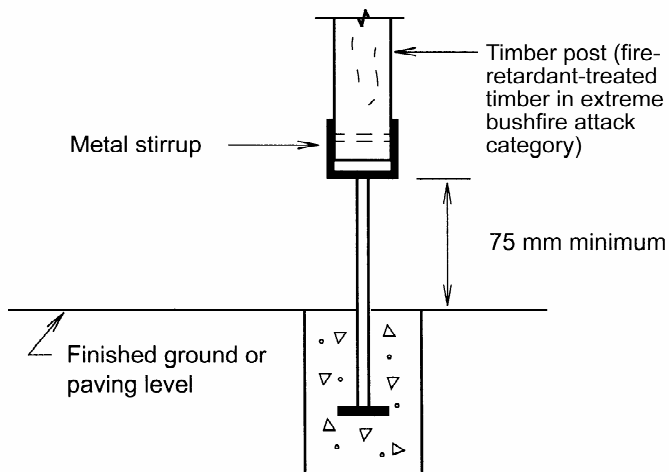
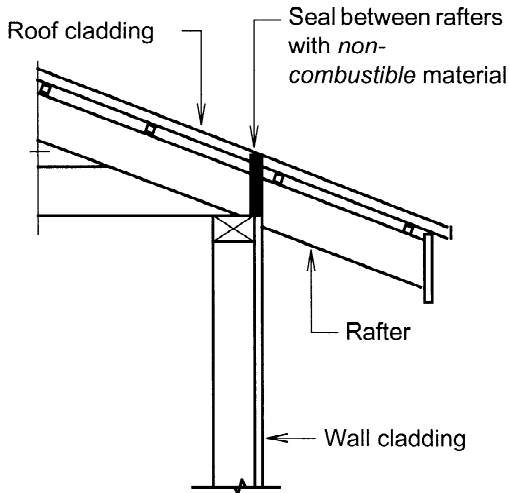

Figure 3.7.4.3

SEALING OF ROOF/WALL JUNCTION

A. Seal between rafters



B. Seal with eaves lining and fascia

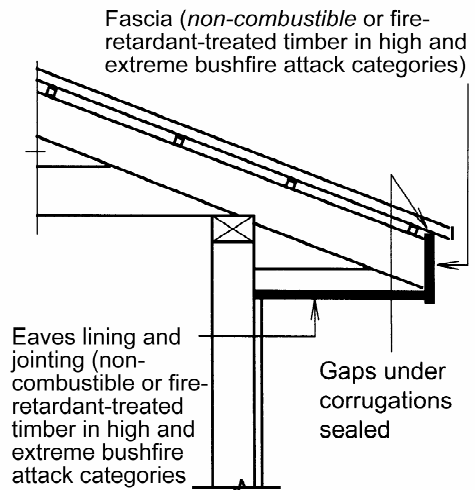
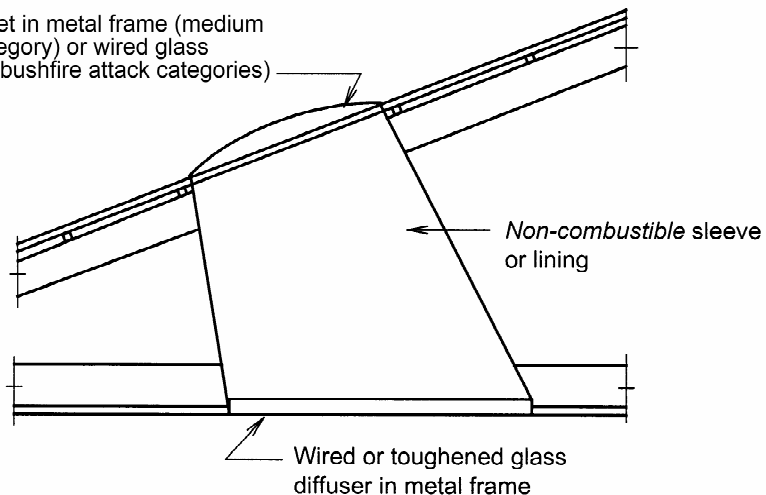

Figure 3.7.4.4

ROOF LIGHTS

Thermoplastic sheet in metal frame (medium bushfire attack category) or wired glass (high and extreme bushfire attack categories)



Explanatory information:

Sub-floor spaces: The method of treating sub-floor spaces is determined by whether sufficient access is available for extinguishment of burning debris that may accumulate beneath the floor. A height of 600 mm has been selected as providing reasonable access for that purpose.

Fully sarked roofs: Where roofing systems are fully sarked, it may be necessary to provide ventilation to prevent moisture condensation from occurring in the roof space. If vents are provided, care needs to be taken to ensure that sparks and embers cannot enter the roof space via the openings.

Termite risk management: If the subject building is *required* to be provided with termite risk management measures, particular care should be taken to ensure that the construction requirements of this Part do not compromise such measures. Details for enclosure of sub-floor spaces and for the protection of *combustible* wall cladding near ground level in particular, may provide a means for concealed access to the building by subterranean termites.

Figure 3.7.4.5
EXTERNAL TIMBERS REGARDED AS PROTECTED

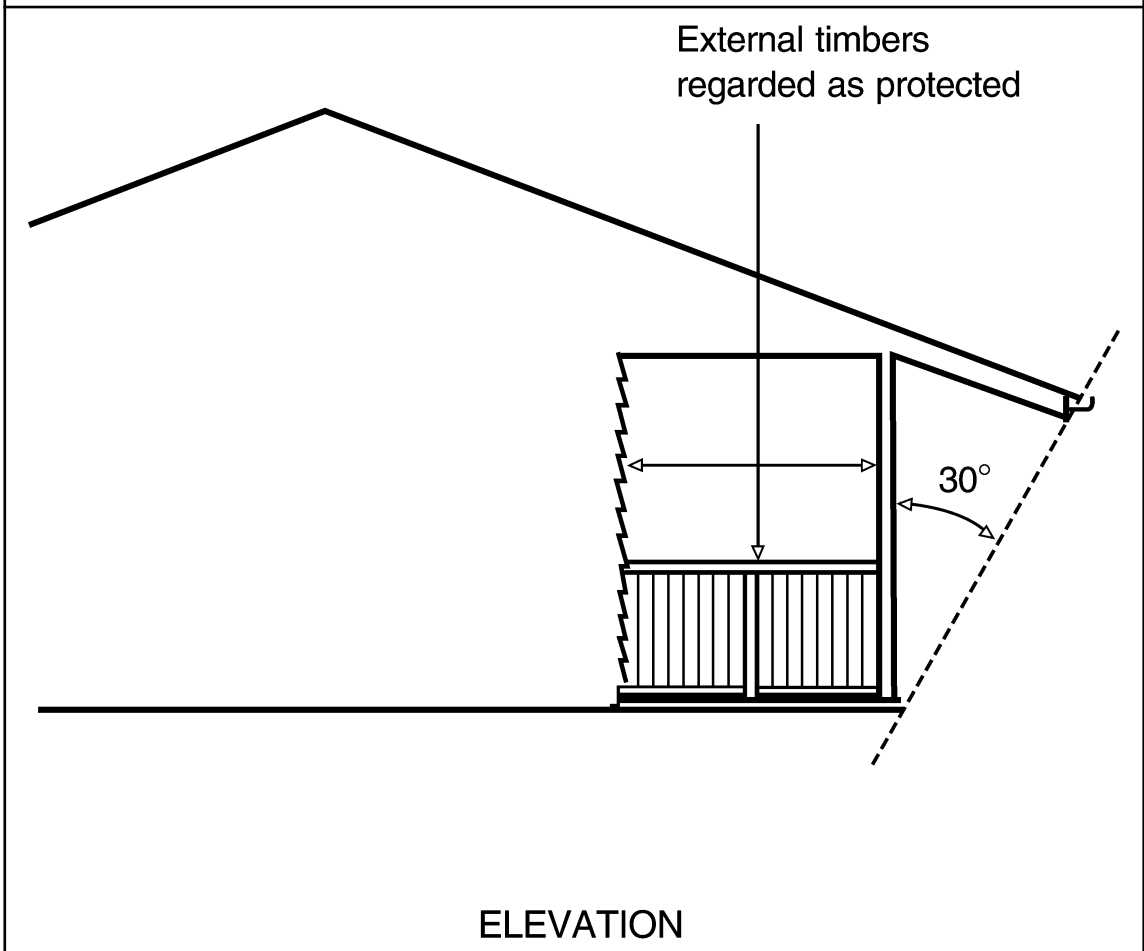

PART 3.7.5 ALPINE AREAS

Appropriate Performance Requirements

Where an alternative *alpine area* egress design is proposed as an *Alternative Solution* to that described in Part 3.7.5, that proposal must comply with—

- (a) Performance Requirement **P2.3.5**; and
- (b) the relevant Performance Requirements determined in accordance with **1.0.10**.

Acceptable construction practice

3.7.5.1 Application

Compliance with this Part for buildings which are located in *alpine areas* (see **Figure 3.7.5.2**) satisfies Performance Requirement **P2.3.5**.

3.7.5.2 External doorways

An external door in a building constructed in an *alpine area*, which may be subject to a build-up of snow must—

- (a) open inwards; and
- (b) be marked “OPEN INWARDS” on the inside face of the door in letters not less than 75 mm high and in a colour contrasting with that of the background; and
- (c) if it serves a corridor or stairway, be positioned in an alcove or recess with—
 - (A) no horizontal dimension of the alcove or recess less than twice the width of the door; and
 - (B) the door positioned to open against a wall such that the distance from any part of its swing to the nearest point of entry of the stairway or corridor is not less than the width of the door.

3.7.5.3 External ramps

An external ramp serving an external doorway must have a gradient not steeper than 1:12.

3.7.5.4 Discharge of external doorways providing a means of egress

A building in an *alpine area* must be constructed so that—

- (a) for any *external walls* more than 3.6 m above the natural ground level, the distance of that part of the building from the allotment boundary (other than a road alignment) must be not less than 2.5 m plus 100 mm for each 300 mm or part by which that part of the *external wall* exceeds a height of 3.6 m; and

- (b) an external doorway may discharge into a court between wings of a building provided the wings are at least 6 m apart; and
- (c) where an external doorway discharges opposite a barrier or embankment which is more than 900 mm above the threshold of that doorway, the distance between the threshold and the barrier is not less than twice the height of the barrier or 6 m, whichever is the lesser (see [Figure 3.7.5.3](#)).

3.7.5.5 External trafficable structures

External stairways, ramps, access bridges or other trafficable structures serving the building must have—

- (a) a floor surface that consists of steel mesh or other suitable material if it is used as a means of egress; and
- (b) any required balustrade or other barrier constructed so that its sides are not less than 75% open.

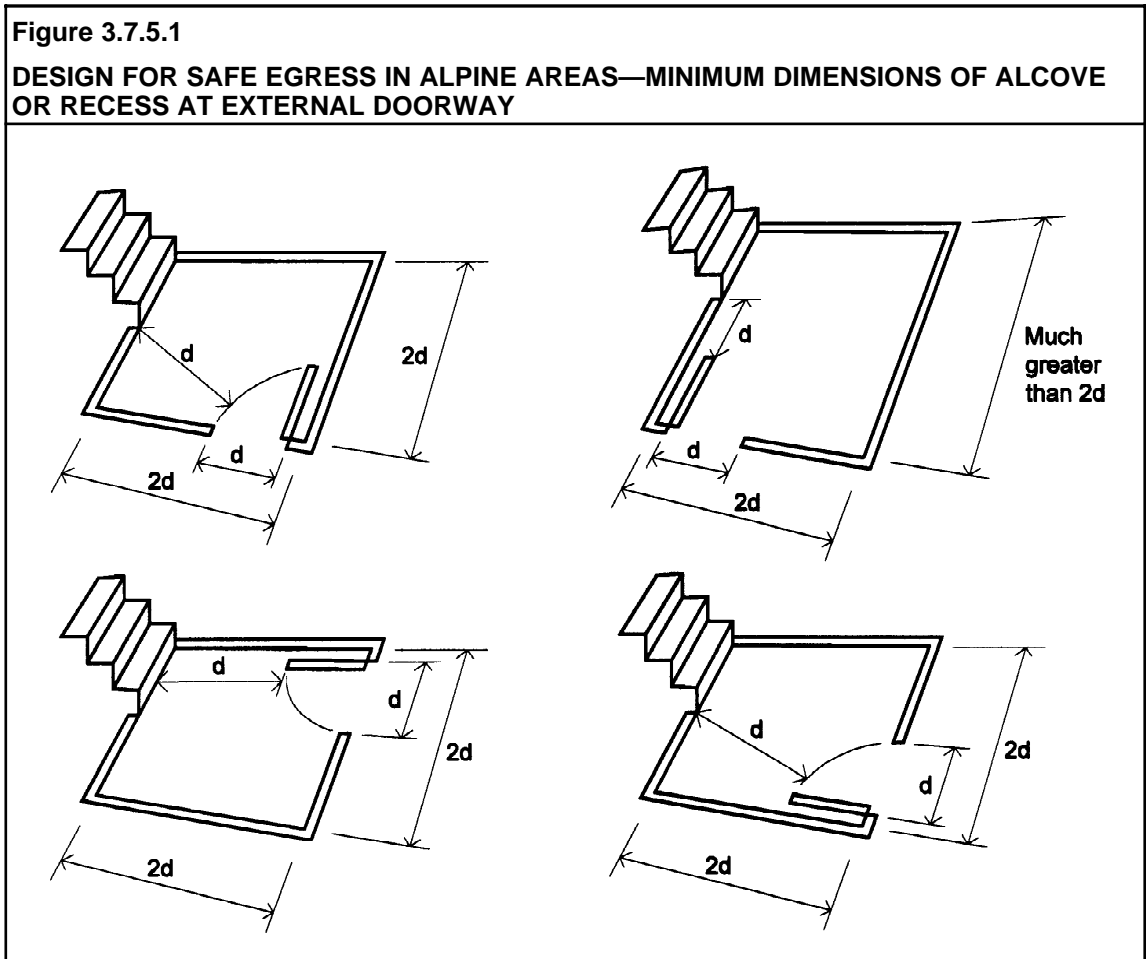
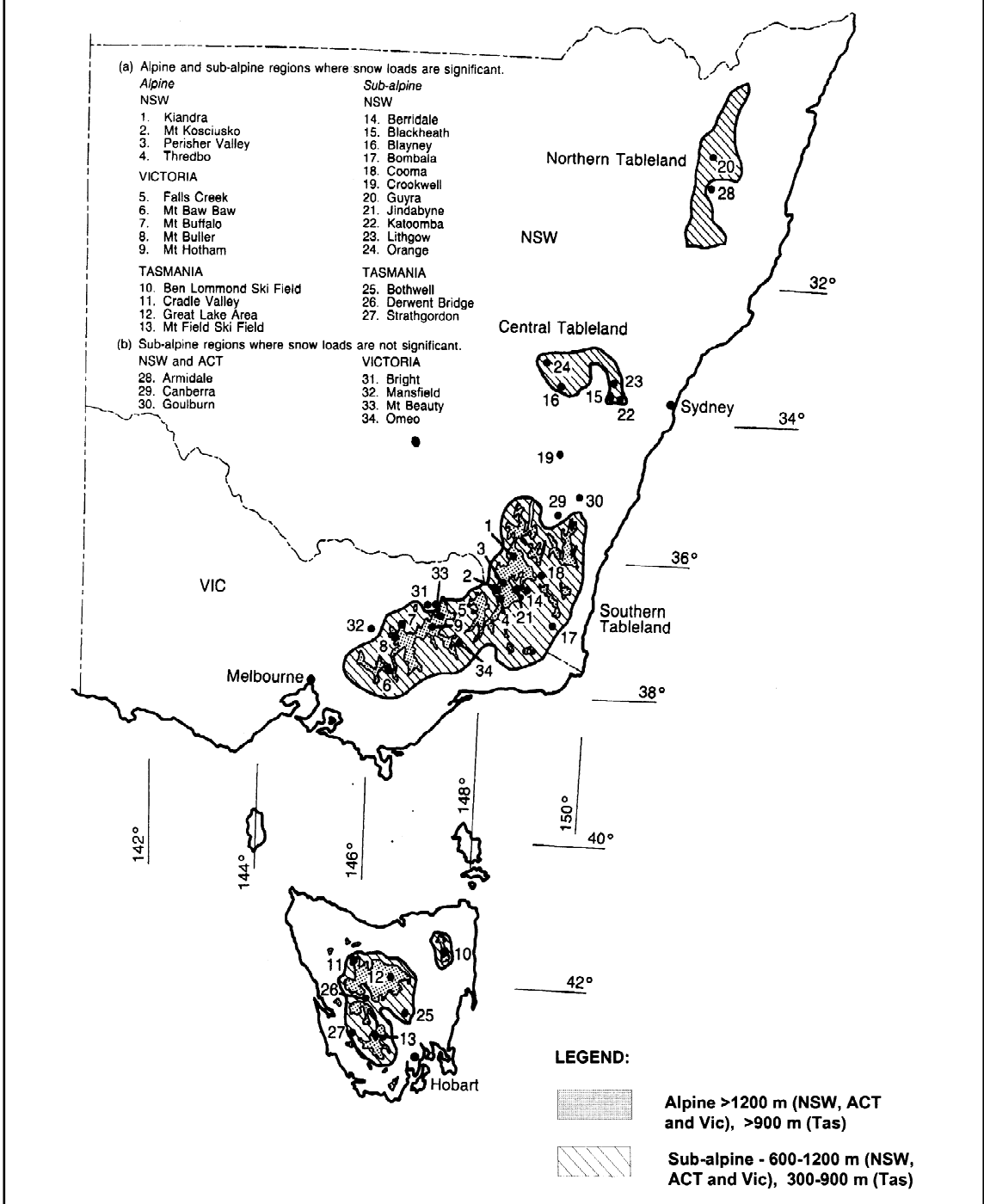

Figure 3.7.5.2

ALPINE AREAS



Explanatory information:

Alpine and sub-alpine areas are located in ACT, NSW, Victoria and Tasmania.

Alpine areas are areas 1200 m or more above Australian Height Datum (AHD) for NSW, ACT and Victoria, and 900 m or more above AHD for Tasmania, as shown in **Figure 3.7.5.2**.

Significant snowfalls (snowfalls which result in an average snow accumulation on the ground of 175 mm or greater) may occur in the sub-alpine areas shown in **Figure 3.7.5.2**. **Part 3.7.5** does not apply to those areas because, unlike alpine areas, successive snowfalls are not likely to accumulate.

It is noted that in the ACT, the Canberra area is designated as a sub-alpine region where snow loads are not considered significant.

Figure 3.7.5.3

DESIGN FOR SAFE EGRESS IN ALPINE AREAS — DISCHARGE OF EXTERNAL DOORWAY

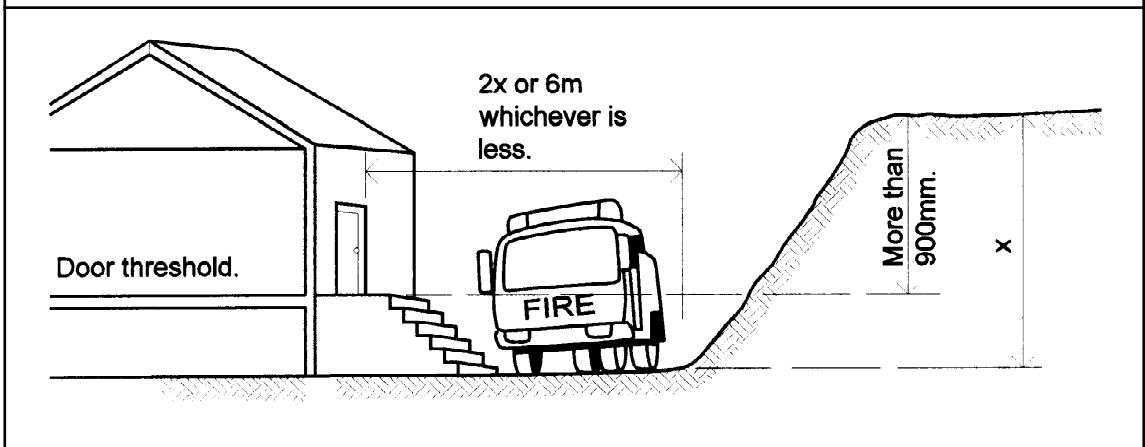

PART **3.8**

HEALTH AND AMENITY

- 3.8.1 Wet Areas**
- 3.8.2 Room Heights**
- 3.8.3 Facilities**
- 3.8.4 Light**
- 3.8.5 Ventilation**
- 3.8.6 Sound Insulation**

PART 3.8 CONTENTS

PART 3.8 HEALTH AND AMENITY

3.8.1 Wet areas

3.8.1 Definitions

3.8.1.0 Acceptable construction manual

3.8.1.1 * * * * *

3.8.2 Room heights

3.8.2.1 Application

3.8.2.2 Ceiling heights

3.8.3 Facilities

3.8.3.1 Application

3.8.3.2 Required facilities

3.8.3.3 Construction of sanitary compartments

3.8.4 Light

3.8.4.1 Application

3.8.4.2 Natural lighting

3.8.4.3 Artificial lighting

3.8.5 Ventilation

3.8.5.0 Acceptable construction manual

3.8.5.1 Application

3.8.5.2 Ventilation requirements

3.8.5.3 Location of sanitary compartments

3.8.6 Sound insulation

3.8.6.1 Application

3.8.6.2 Sound insulation requirements

3.8.6.3 General installation requirements for walls

3.8.6.4 Services

PART 3.8.1 WET AREAS

Appropriate *Performance Requirements*

Where an alternative system for protecting *wet areas* is proposed as an *Alternative Solution* to that described in Part 3.8.1, that proposal must comply with—

- (a) *Performance Requirement* **P2.4.1**; and
- (b) the relevant *Performance Requirements* determined in accordance with **1.0.10**.

Definitions:

3.8.1 * * * * *

This clause has deliberately been left blank.

A. Acceptable construction manual

3.8.1.0

Performance Requirement **P2.4.1** is satisfied for *wet areas* in Class 1 and 10 buildings if they are *waterproofed* in accordance with AS 3740—Waterproofing of wet areas within residential buildings.

STATE AND TERRITORY VARIATIONS

3.8.1.0 is replaced in South Australia with the following clause.

Performance Requirements **P2.4.1** and SA 3.1 are satisfied for *wet areas* in Class 1 and 10 buildings if they are waterproofed in accordance with AS 3740 and the additional requirements of Minister's Specification SA F1.7.

B. Acceptable construction practice

3.8.1.1 * * * * *

This clause has deliberately been left blank.

PART 3.8.2 ROOM HEIGHTS

Appropriate Performance Requirements

Where an alternative ceiling height is proposed as an *Alternative Solution* to that described in Part 3.8.2, that proposal must comply with—

- (a) *Performance Requirement* **P2.4.2**; and
- (b) the relevant *Performance Requirements* determined in accordance with **1.0.10**.

Acceptable construction practice

3.8.2.1 Application

Compliance with this Part satisfies *Performance Requirement* **P2.4.2** for room heights.

3.8.2.2 Ceiling heights

Ceiling heights (see **Figure 3.8.2.1**) must be not less than—

- (a) in a *habitable room* excluding a kitchen—2.4 m; and
- (b) in a kitchen—2.1 m; and
- (c) in a corridor, passageway or the like—2.1 m; and
- (d) in a bathroom, shower room, laundry, *sanitary compartment*, airlock, pantry, storeroom, garage, car parking area or the like—2.1 m; and
- (e) in an attic room, room with a sloping ceiling or projection below ceiling line or a *non-habitable room* or similar space—a height that does not unduly interfere with the proper functioning of the room or space; and
- (f) in a stairway—2.0 m measured vertically above the nosing line.

Figure 3.8.2.1

MEASUREMENT OF ACCEPTABLE CEILING HEIGHTS

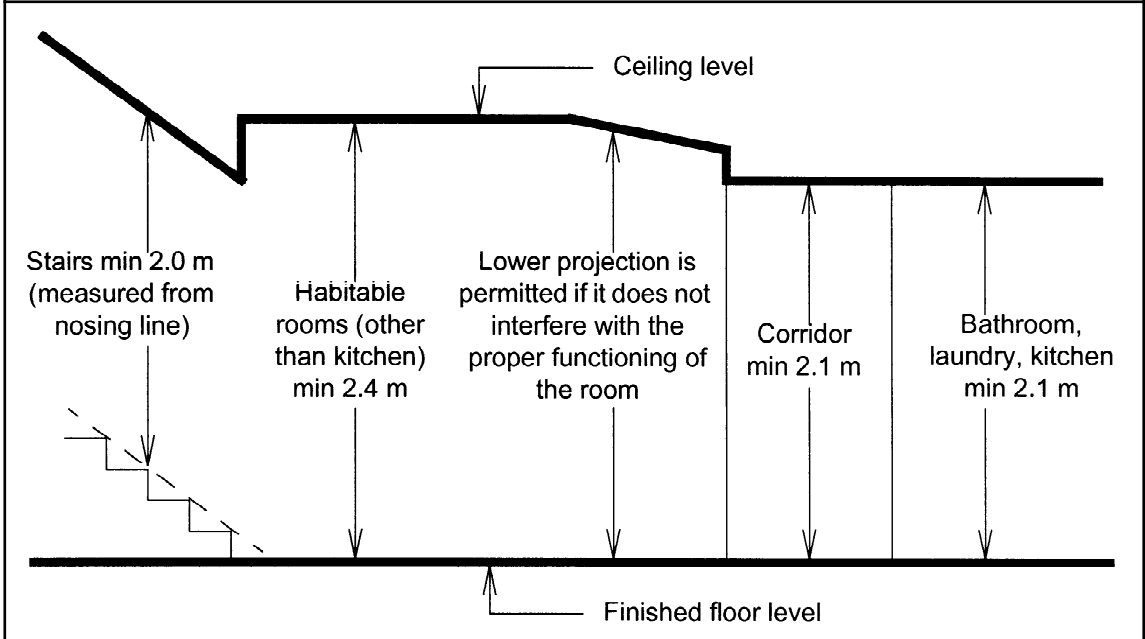

PART 3.8.3 FACILITIES

Appropriate Performance Requirements

Where an alternative arrangement for facilities is proposed as an *Alternative Solution* to that described in Part 3.8.3, that proposal must comply with—

- (a) *Performance Requirement* P2.4.3; and
- (b) the relevant *Performance Requirements* determined in accordance with 1.0.10.

Acceptable construction practice

3.8.3.1 Application

Compliance with this Part satisfies *Performance Requirement* P2.4.3 for facilities.

3.8.3.2 Required facilities

- (a) A Class 1 building must be provided with—
 - (i) a kitchen sink and facilities for the preparation and cooking of food; and
 - (ii) a bath or shower; and
 - (iii) clothes washing facilities, comprising at least one washtub and space in the same room for a washing machine; and
 - (iv) a closet pan and washbasin.
- (b) If any of the facilities in (a) are detached from the main building, they must be set aside for the exclusive use of the occupants of the building.

3.8.3.3 Construction of sanitary compartments

The door to a fully enclosed *sanitary compartment* must—

- (a) open outwards; or
- (b) slide; or
- (c) be readily removable from the outside of the compartment,

unless there is a clear space of at least 1.2 m between the closet pan within the *sanitary compartment* and the nearest part of the doorway.

Explanatory information:

3.8.3.3 requires means of removing an unconscious occupant from a fully enclosed sanitary compartment. If the enclosure has gaps that are large enough to allow access for a person into the *sanitary compartment*, the compartment is not considered enclosed for the purpose of this clause.

STATE AND TERRITORY VARIATIONS

Part 3.8.3.4 is added as follows in Tasmania.

Installation of closet fixtures

- (a) If a sufficient sewerage system is not available, an authorised alternative means of disposal of sewage, may be installed.
- (b) If sanitary facilities are not water-flushed, the following provisions apply.
 - (i) A pit latrine, an incinerating toilet, a chemical toilet, a removable pan or a non-flushing urinal must not be within 2 m of a building containing habitable rooms.
 - (ii) The floor on which a removable pan is placed must be impervious.
 - (iii) A room containing a composting toilet must be separated from habitable rooms by way of a permanently ventilated air lock (which may be a circulation space).
 - (iv) The minimum ventilation *required* under (iii) shall be the greater of—
 - (A) 8000 mm² ; or
 - (B) 1/500th of the *floor area* of the circulation space.
 - (v) Access for maintenance or removal of waste from a composting toilet must be by way of an access door which opens directly to the outside of the building.

PART 3.8.4 LIGHT

Appropriate Performance Requirements

Where an alternative lighting system is proposed as an *Alternative Solution* to that described in Part 3.8.4, that proposal must comply with—

- (a) *Performance Requirement P2.4.4*; and
- (b) the relevant *Performance Requirements* determined in accordance with **1.0.10**.

Acceptable construction practice

3.8.4.1 Application

Compliance with this Part for a Class 1 building satisfies *Performance Requirement P2.4.4* for lighting.

3.8.4.2 Natural lighting

Natural lighting must be provided in a Class 1 building to all *habitable rooms*, in accordance with the following:

- (a) Natural lighting must be provided by *windows* that—
 - (i) have an aggregate light transmitting area measured exclusive of framing members, glazing bars or other obstructions of not less than 10% of the *floor area* of the room; and
 - (ii) are open to the sky or face a court or other space open to the sky or an open verandah, carport or the like.
- (b) A *window required* to provide natural light that faces a boundary of an adjoining allotment must not be less than a horizontal distance of 900 mm from that boundary.
- (c) Natural lighting to a room in a Class 1 building may come through a glazed panel or opening from an adjoining room (including an enclosed verandah) if—
 - (i) the glazed panel or opening has an area of not less than 10% of the *floor area* of the room to which it provides light; and
 - (ii) the adjoining room has *windows* with an aggregate light transmitting area of not less than 10% of the combined *floor areas* of both rooms; and
 - (iii) the areas specified in (i) and (ii) may be reduced as appropriate if direct natural light is provided from another source.

(see **Figure 3.8.4.1**)

Figure 3.8.4.1

METHOD OF DETERMINING AREAS OF OPENINGS FOR BORROWED LIGHT

$$A = \frac{a \times b}{10} \text{ m}^2$$

$$B = \frac{a \times c}{10} \text{ m}^2$$

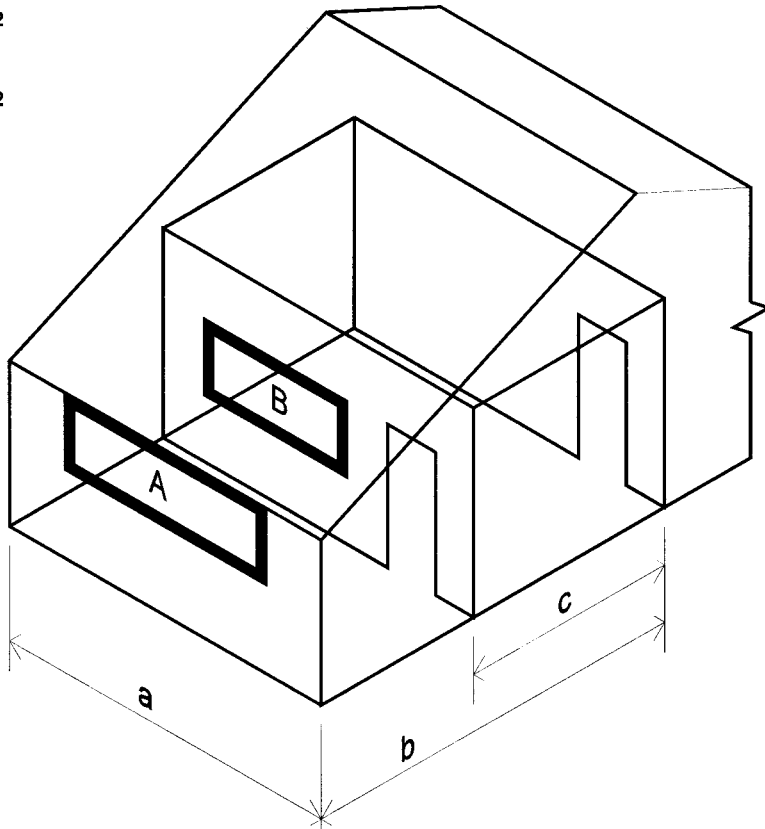

3.8.4.3 Artificial lighting

Sanitary compartments, bathrooms, shower rooms, airlocks and laundries must be provided with artificial light if natural lighting in accordance with the relevant provisions of 3.8.4.2 is not available—

- (a) at a rate of not less than one light fitting per 16 m² of *floor area*; or
- (b) in accordance with AS/NZS 1680.0.

PART 3.8.5 VENTILATION

Appropriate Performance Requirements

Where an alternative ventilation system is proposed as an *Alternative Solution* to that described in Part 3.8.5, that proposal must comply with—

- (a) *Performance Requirement P2.4.5*; and
- (b) the relevant *Performance Requirements* determined in accordance with **1.0.10**.

Explanatory information:

The requirements of this Part are to be read in conjunction with the air movement requirements in Part 3.12.4. However, it should be noted that Part 3.12.4 does not apply in the Australian Capital Territory, New South Wales and Victoria.

A. Acceptable construction manual

3.8.5.0

Performance Requirement P2.4.5 is satisfied for a mechanical ventilation system if it is installed in accordance with AS 1668.2—Mechanical ventilation for acceptable indoor air quality, except that any contaminated air from a *sanitary compartment* or bathroom must—

- (a) exhaust directly to outside the building by way of ducts; or
- (b) exhaust into the roof space provided—
 - (i) it is adequately ventilated by open eaves, and/or roof vents; or
 - (ii) the roof is clad in roofing tiles without sarking or similar materials which would prevent venting through gaps between tiles.

B. Acceptable construction practice

3.8.5.1 Application

Compliance with this Part satisfies *Performance Requirement P2.4.5* for ventilation.

3.8.5.2 Ventilation requirements

Ventilation must be provided to a *habitable room*, *sanitary compartment*, bathroom, shower room, laundry and any other room occupied by a person for any purpose by any of the following means:

- (a) Permanent openings, *windows*, doors or other devices which can be opened—

- (i) with an aggregate opening or openable size not less than 5% of the *floor area* of the room *required* to be ventilated; and
- (ii) open to—
 - (A) a suitably sized court, or space open to the sky; or
 - (B) an open verandah, carport, or the like; or
 - (C) an adjoining room in accordance with (b).
- (b) Natural ventilation to a room may come through a *window*, opening, ventilating door or other device from an adjoining room (including an enclosed verandah) if—
 - (i) the room to be ventilated or the adjoining room is not a *sanitary compartment*; and
 - (ii) the *window*, opening, door or other device has a ventilating area of not less than 5% of the *floor area* of the room to be ventilated; and
 - (iii) the adjoining room has a *window*, opening, door or other device with a ventilating area of not less than 5% of the combined *floor areas* of both rooms; and
 - (iv) the ventilating areas specified may be reduced as appropriate if direct natural ventilation is provided from another source.

(See [Figure 3.8.5.1](#))

Figure 3.8.5.1

METHOD OF DETERMINING AREAS OF OPENINGS FOR BORROWED VENTILATION

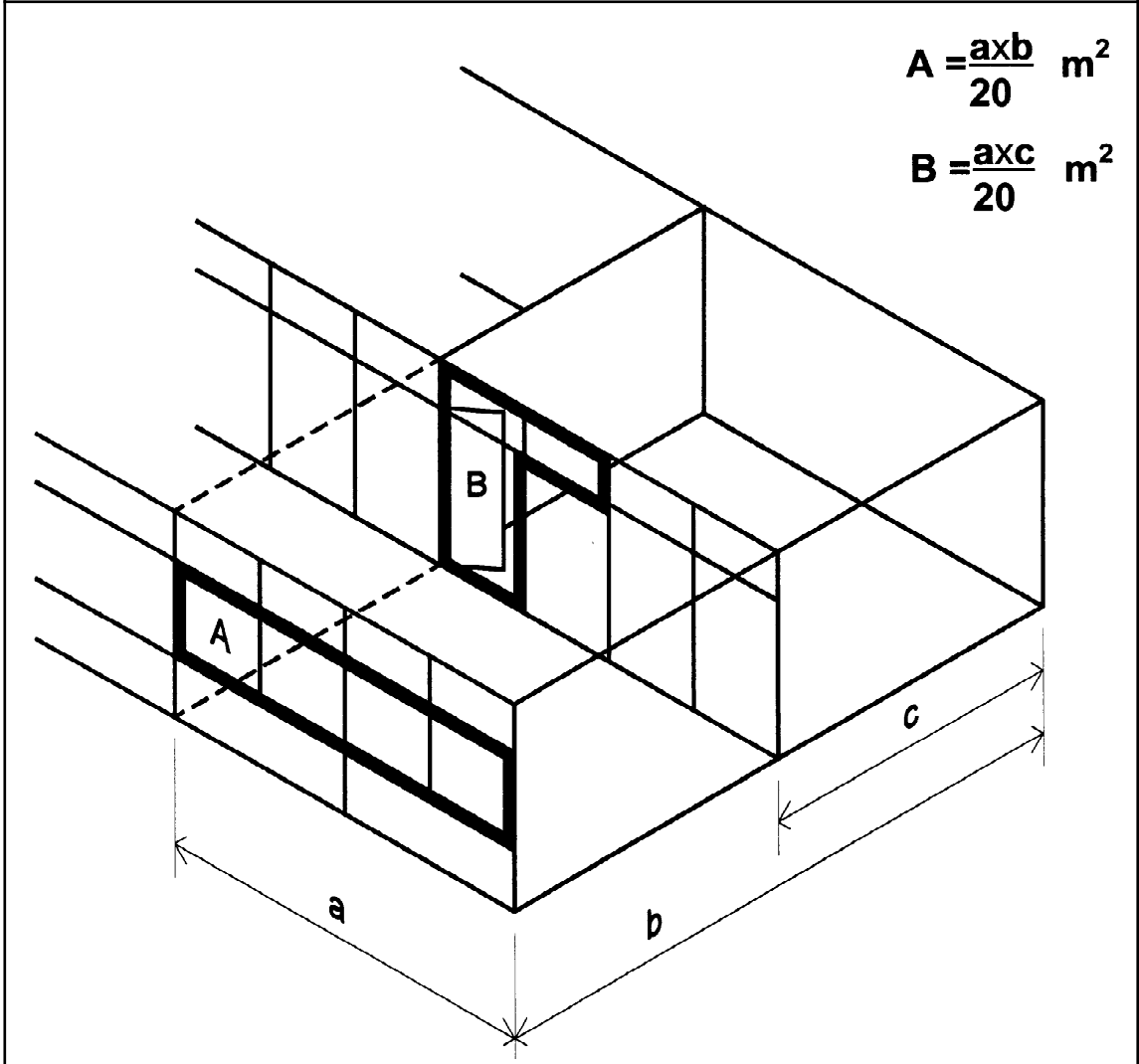

3.8.5.3 Location of sanitary compartments

Sanitary compartments must not open directly into a kitchen or pantry unless—

- (a) access is by an airlock, hallway or other room, (see [Figure 3.8.5.2](#)); or
- (b) the room containing the closet pan is provided with mechanical exhaust ventilation installed in accordance with [Part 3.8.5](#).

Figure 3.8.5.2

ACCEPTABLE LOCATION OF NON MECHANICALLY VENTILATED SANITARY COMPARTMENT

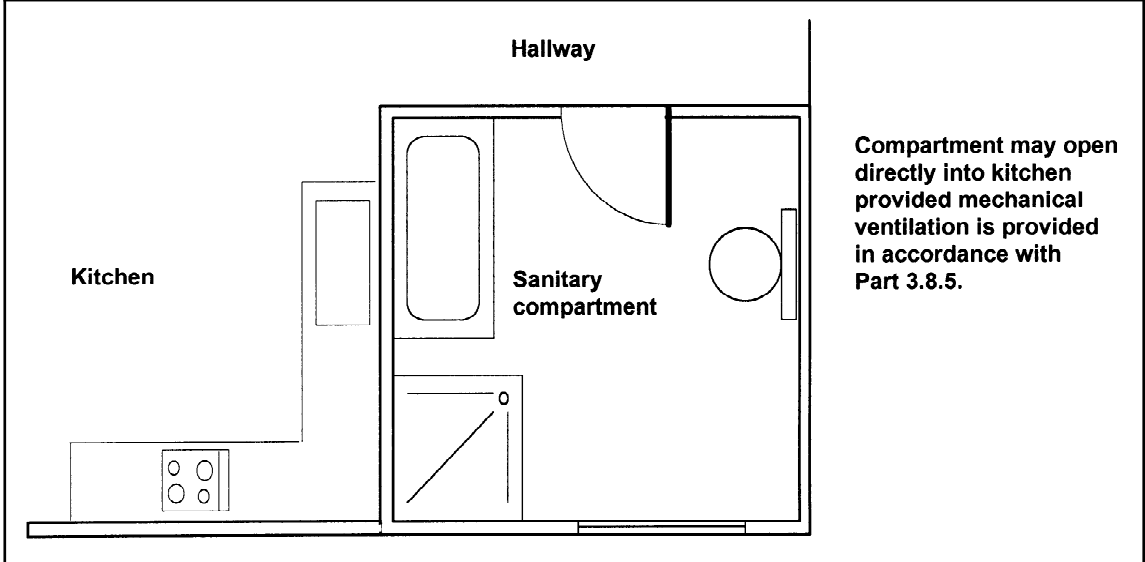

PART 3.8.6 SOUND INSULATION

Appropriate Performance Requirements

Where an alternative sound insulation system is proposed as an *Alternative Solution* to that described in Part 3.8.6, that proposal must comply with—

- (a) *Performance Requirement* **P2.4.6**; and
- (b) the relevant *Performance Requirements* determined in accordance with **1.0.10**.

Acceptable construction practice

3.8.6.1 Application

Compliance with this Part satisfies *Performance Requirement* **P2.4.6** for sound insulation.

3.8.6.2 Sound insulation requirements

- (a) To provide insulation from airborne and impact sound, a separating wall between two or more Class 1 buildings must—
 - (i) achieve the weighted sound reduction index with spectrum adaptation term ($R_w + C_{tr}$) and discontinuous construction requirements, as *required* by **Table 3.8.6.1**; and
 - (ii) be installed in accordance with the appropriate requirements of **3.8.6.3** and **3.8.6.4**.
- (b) For the purpose of this Part, the $R_w + C_{tr}$ must be determined in accordance with AS/NZS 1276.1 or ISO 717.1, using results from laboratory measurements.

Table 3.8.6.1 REQUIRED AIRBORNE AND IMPACT SOUND LEVELS FOR SEPARATING WALLS

SEPARATING WALL—LOCATION AND PENETRATIONS	DISCONTINUOUS CONSTRUCTION REQUIRED	$R_w + C_{tr}$ (As per Table 3.8.6.2)
Between a bathroom, <i>sanitary compartment</i> , laundry or kitchen and a <i>habitable room</i> (other than a kitchen) in an adjoining Class 1 building (dwelling) (see Figure 3.8.6.1).	YES	50
In all other cases to those listed above. (See Figure 3.8.6.1)	NO	50

SEPARATING WALL—LOCATION AND PENETRATIONS	DISCONTINUOUS CONSTRUCTION REQUIRED	$R_w + C_{tr}$ (As per Table 3.8.6.2)
Duct, Soil, Waste, Water Supply and Storm Water Pipes		
A duct, soil, waste, water supply pipe or storm water pipe that passes through a <i>separating wall</i> between Class 1 buildings—		
(a) if the adjacent room is a <i>habitable room</i> (other than a kitchen); or	NO	40
(b) if the room is a kitchen or any other room.	NO	25
Note:		
Discontinuous construction means a wall system having a minimum 20 mm cavity between two separate leaves, with—		
(a)	for masonry, where wall ties are required to connect leaves, the ties are of the resilient type; and	
(b)	for other than masonry, there is no mechanical linkage between leaves except at the periphery.	
A staggered stud wall is not deemed to be discontinuous construction.		

Figure 3.8.6.1

REQUIRED AIRBORNE AND IMPACT SOUND INSULATION—PLAN VIEW

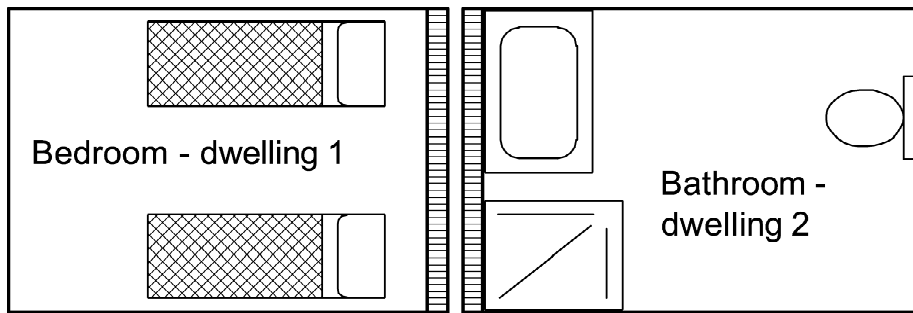

Rw + Ctr 50
and
discontinuous construction

(a) Adjoining bedroom/bathroom

Waste pipe - must be separated from the adjoining dwelling if it passes through a separating wall, by a wall with a $Rw + Ctr 40$, this may be reduced to a $Rw + Ctr 25$ if the adjoining room is kitchen

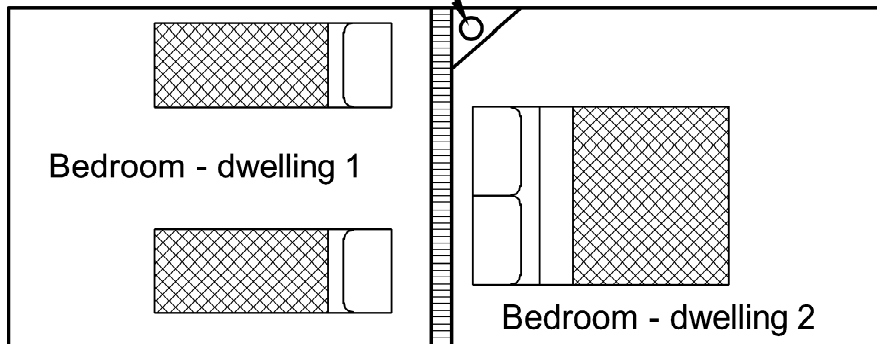

Rw + Ctr 50

(b) Adjoining bedrooms

3.8.6.3 General installation requirements for walls

- (a) To achieve the appropriate level of sound insulation, walls must—
 - (i) be constructed in accordance with the appropriate requirements contained in (b) to (f); and

- (ii) at the junction of sound insulated walls with any perimeter walls and roof cladding, be sealed in accordance with [Figure 3.8.6.2](#).

Figure 3.8.6.2

SOUND INSULATION BETWEEN BUILDINGS—STAGGERED STUD WALL CONFIGURATION

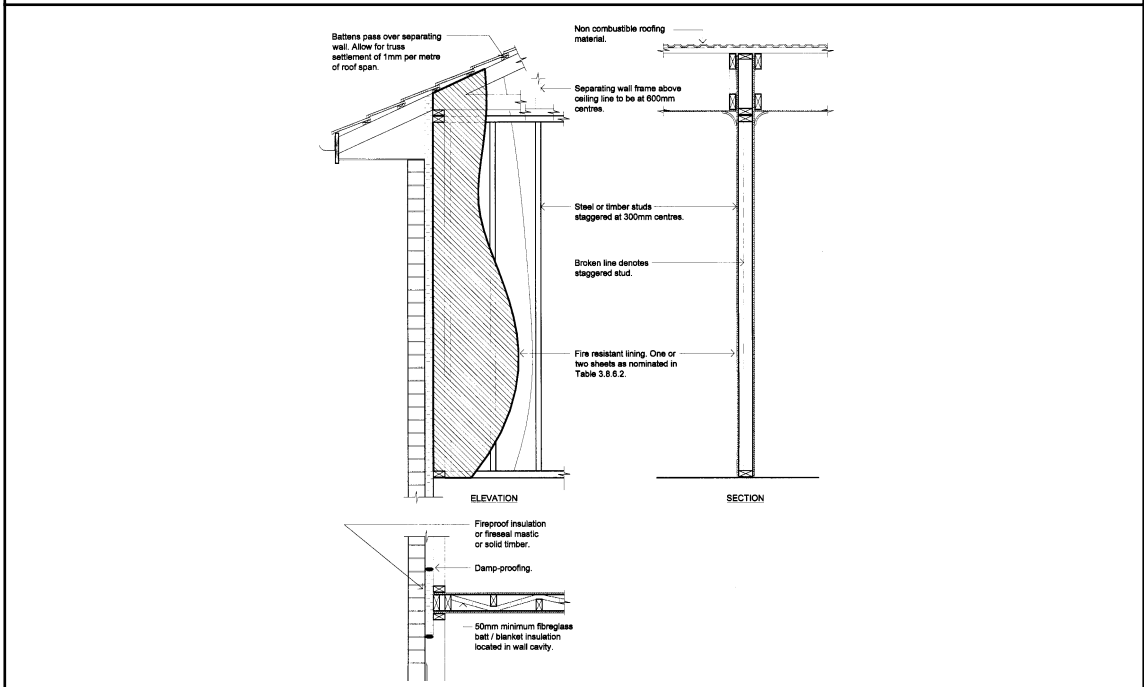

- (b) Masonry units must be laid with all joints filled solid, except for adequately sound insulated articulation joints, including those between the masonry and any adjoining construction.
- (c) Concrete panels must have joints between panels and any adjoining construction filled solid.
- (d) Sheeting materials must be installed as follows:
- (i) If one layer is *required* on both sides of a wall the joints must be staggered on opposite sides (See [Figure 3.8.6.3](#)).
 - (ii) If 2 layers are *required*, the first layer must be fastened in accordance with (i) and the second layer joints must not coincide with those of the first layer (See [Figure 3.8.6.3](#)).
 - (iii) The following joints must be taped and filled solid:
 - (A) Outer layer joints between sheets.
 - (B) Joints between sheets and any adjoining construction.

Figure 3.8.6.3

TYPICAL INSTALLATION OF PLASTER SHEETS FOR SOUND INSULATION

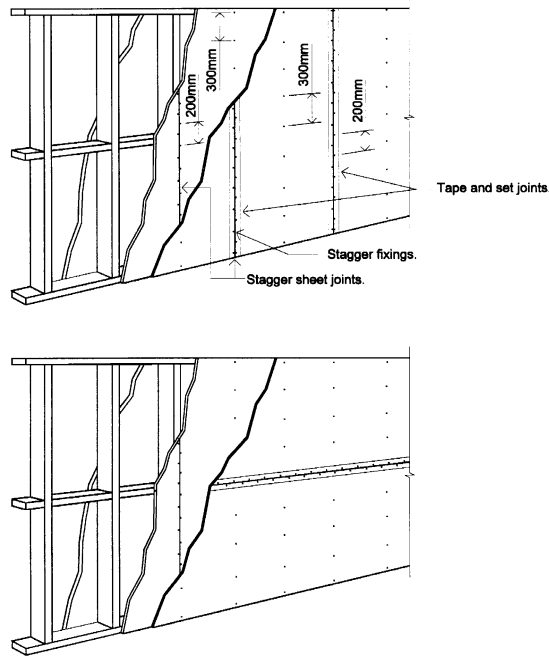

- (e) Steel framing must be installed as follows:
- (i) The section of steel must be not less than 0.6 mm thick.
 - (ii) Studs must be not less than 63 mm in depth unless another depth is specified in [Table 3.8.6.2](#).
 - (iii) Studs must be fixed to steel top and bottom plates of sufficient depth to permit secure fixing of the plasterboard.
 - (iv) All steel members at the perimeter of the wall must be securely fixed to the adjoining structure and bedded in resilient compound or the joints must be caulked so that there are no voids between the steel members and the wall.
- (f) Timber framing must be installed as follows:
- (i) Studs must be fixed to top and bottom plates of sufficient depth to permit secure fixing of the plasterboard.
 - (ii) Noggings and like members must not bridge between studs supporting different wall leaves.
 - (iii) All timber members at the perimeter of the wall must be securely fixed to the adjoining structure and bedded in resilient compound or the joints must be caulked so there are no voids between the timber members and the wall.

3.8.6.4 Services

- (a) Services must not be chased into concrete or masonry *separating walls*.

- (b) If a duct, soil, waste, water supply or storm water pipe serves or passes through a *separating wall* or is located in a *separating wall*—
- (i) a door or panel providing access to a duct or pipe required to be separated must—
 - (A) not open into any *habitable room*, other than a kitchen; and
 - (B) in any other part must be firmly fixed so as to overlap the frame or rebate of the frame by not less than 10 mm and be constructed of—
 - (aa) wood, plasterboard or blockboard not less than 33 mm thick; or
 - (bb) compressed fibre reinforced cement sheeting not less than 9 mm thick; or
 - (cc) other suitable material with a mass per unit area not less than 24.4 kg/m²; and
 - (ii) in the case of a water supply pipe, it must—
 - (A) only be installed in discontinuous construction; and
 - (B) in the case of a water supply pipe that serves one dwelling, not be fixed to the wall leaf on the side of any other dwelling and have a clearance not less than 10 mm to the other wall leaf.
- (c) Electrical outlets must be offset from each other—
- (i) in masonry walling, not less than 100 mm; and
 - (ii) in timber or steel framed walling, not less than 300 mm.

Table 3.8.6.2 ACCEPTABLE FORMS OF CONSTRUCTION

Description	$R_w + C_{tr}$ (not less than)	Design Diagram—Plan View
Wall construction type: Masonry		
Two leaves of 110 mm clay brick masonry with: <ul style="list-style-type: none"> (a) cavity not less than 50 mm between leaves; and (b) 50 mm thick glass wool insulation with a density of 11 kg/m³ or 50 mm thick polyester insulation with a density of 20 kg/m³ in the cavity. 	50	
Two leaves of 110 mm clay brick masonry with: <ul style="list-style-type: none"> (a) cavity not less than 50 mm between leaves; and (b) 13 mm cement render on each outside face. 	50	

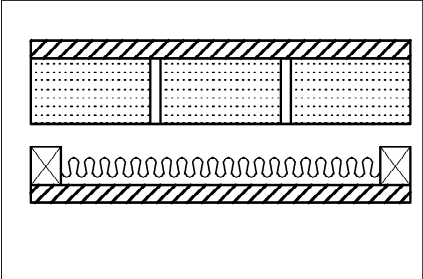
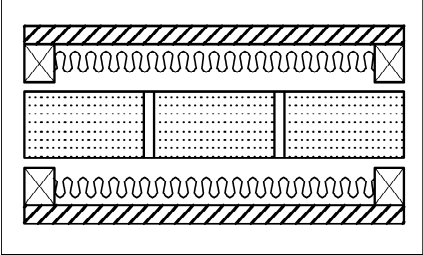
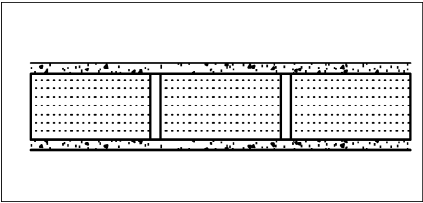
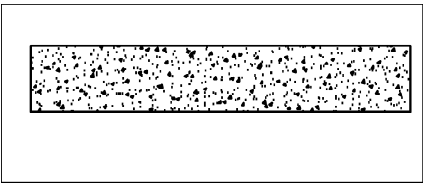
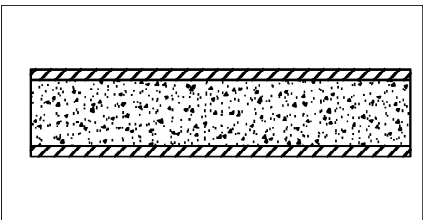
Description	$R_w + C_{tr}$ (not less than)	Design Diagram—Plan View
Single leaf of 110 mm clay brick masonry with: <ul style="list-style-type: none"> (a) a row of 70 mm x 35 mm timber studs or 64 mm steel studs at 600 mm centres, spaced 20 mm from the masonry wall; and (b) 50 mm thick mineral insulation or glass wool insulation with a density of 11 kg/m³ positioned between studs; and (c) one layer of 13 mm plasterboard fixed to outside face of studs and outside face of masonry. 	50	
Single leaf of 90 mm clay brick masonry with: <ul style="list-style-type: none"> (a) a row of 70 mm x 35 mm timber studs or 64 mm steel studs at 600 mm centres, spaced 20 mm from each face of the masonry wall; and (b) 50 mm thick mineral insulation or glass wool insulation with a density of 11 kg/m³ positioned between studs in each row; and (c) one layer of 13 mm plasterboard fixed to studs on each outside face. 	50	
Single leaf of 220 mm brick masonry with 13 mm cement render on each face.	50	
Wall construction type: Concrete		
150 mm thick plain off form concrete.	50	
200 mm thick concrete panel with one layer of 13 mm plasterboard or 13 mm cement render on each face.	50	

Description	$R_w + C_{tr}$ (not less than)	Design Diagram—Plan View
<p>100 mm thick concrete panel with:</p> <p>(a) a row of 64 mm steel studs at 600 mm centres, spaced 25 mm from the concrete panel; and</p> <p>(b) 80 mm thick polyester insulation or 50 mm thick glass wool insulation with a density of 11 kg/m³, positioned between studs; and</p> <p>(c) two layers of 13 mm plasterboard fixed to outside face of studs and one layer of 13 mm plasterboard fixed to outside face of concrete panel.</p>	50	
<p>125 mm thick concrete panel with:</p> <p>(a) a row of 64 mm steel studs at 600 mm centres, spaced 20 mm from the concrete panel; and</p> <p>(b) 70 mm polyester insulation with a density of 9 kg/m³, positioned between studs; and</p> <p>(c) one layer of 13 mm plasterboard fixed to the outside face of the studs.</p>	50	
Wall construction type: Autoclaved aerated concrete		
<p>75 mm thick autoclaved aerated concrete wall panel with:</p> <p>(a) a row of 64 mm steel studs at 600 mm centres, spaced 20 mm from the autoclaved aerated concrete wall panel; and</p> <p>(b) 75 mm thick glass wool insulation with a density of 11 kg/m³ positioned between studs; and</p> <p>(c) one layer of 10 mm moisture resistant plasterboard or 13 mm fire protective grade plasterboard fixed to outside face of studs and outside face of autoclaved aerated concrete wall panel.</p>	50	

Description	$R_w + C_{tr}$ (not less than)	Design Diagram—Plan View
<p>75 mm thick autoclaved aerated concrete wall panel with:</p> <p>(a) a row of 64 mm steel studs at 600 mm centres, spaced 35 mm from the autoclaved aerated concrete panel wall; and</p> <p>(b) 28 mm metal furring channels fixed to the outside face of the autoclaved aerated concrete wall panel, with 50 mm thick polyester insulation with a density of 9 kg/m³ positioned between furring channels and one layer of 13 mm fire protective grade plasterboard fixed to furring channels; and</p> <p>(c) 105 mm thick glass wool insulation with a density of 7 kg/m³ positioned between studs; and</p> <p>(d) one layer of 13 mm fire protective grade plasterboard fixed to the outside face of the studs.</p>	50	
<p>Two leaves of 75 mm autoclaved aerated concrete wall panel with:</p> <p>(a) a cavity not less than 30 mm between panels containing 50 mm glass wool insulation with a density of 11 kg/m³; and</p> <p>(b) one layer of 10 mm plasterboard fixed to outside face of each panel.</p>	50	
Wall construction type: Timber and steel framing		
<p>Two rows of 90 x 35 mm timber studs or two rows of 64 mm steels studs at 600 mm centres with:</p> <p>(a) an air gap not less than 20 mm between the rows of studs; and</p> <p>(b) 50 mm thick glass wool insulation or 60 mm thick polyester insulation with a density of 11 kg/m³; positioned between one row of studs, and</p> <p>(c) two layers of 13 mm fire protective grade plasterboard or one layer of 6 mm fibre cement sheet and one layer of 13 mm fire protective grade plasterboard, fixed to outside face of studs.</p>	50	

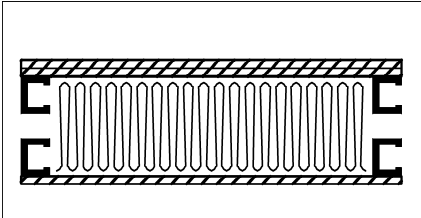
Description	$R_w + C_{tr}$ (not less than)	Design Diagram—Plan View
<p>Two rows of 64 mm steel studs at 600 mm centres with:</p> <p>(a) an air gap not less than 80 mm between the rows of studs; and</p> <p>(b) 200 mm thick polyester insulation with a density of 14 kg/m³; positioned between studs; and</p> <p>(c) one layer of 13 mm fire-protective grade plasterboard and one layer 13 mm plasterboard on one outside face and one layer of 13 mm fire-protective grade plasterboard on the other outside face.</p>	50	

Explanatory information:

The wall configurations shown in Tables 3.8.6.2 are typical examples. Other proprietary methods are available for meeting the $R_w + C_{tr}$ requirements of 3.8.6.2.

STATE AND TERRITORY VARIATIONS

In Northern Territory, Queensland and Western Australia Part 3.8.6 acceptable construction practice is replaced with the following.

Acceptable construction practice

3.8.6.1 Application

Compliance with this Part satisfies *Performance Requirement P2.4.6* for sound insulation.

3.8.6.2 Sound insulation requirements

- (a) A *separating wall* between two or more Class 1 buildings must—
 - (i) achieve the weighted sound reduction index (R_w) and impact sound resistance required by [Table 3.8.6.1](#); and
 - (ii) be installed in accordance with the appropriate requirements of [3.8.6.3](#) and [3.8.6.4](#); and
- (b) for the purpose of this Part, the R_w may be determined in accordance with AS/NZS 1276.1 or ISO 717.1.

Table 3.8.6.1 REQUIRED R_w AND SOUND IMPACT LEVELS FOR SEPARATING WALLS

SEPARATING WALL—LOCATION AND PENETRATIONS		IMPACT SOUND RESISTANCE (As per Table 3.8.6.2)	R_w (As per Table 3.8.6.3)
TYPE A	Between a bathroom, <i>sanitary compartment</i> , laundry or kitchen and a <i>habitable room</i> (other than a kitchen) in an adjoining Class 1 building (dwelling) (see Figure 3.8.6.1).	YES	50
TYPE B	In all other cases to those listed as Type A. (See Figure 3.8.6.1)	NO	45
SOIL AND WASTE PIPES			
A waste pipe or other penetration that serves or passes through a <i>separating wall</i> between houses—			
(a)	If the adjacent room is a <i>habitable room</i> (other than a kitchen); or	NO	45
(b)	If the room is a kitchen or any other room.	NO	30

Figure 3.8.6.1

REQUIRED R_w — PLAN VIEW

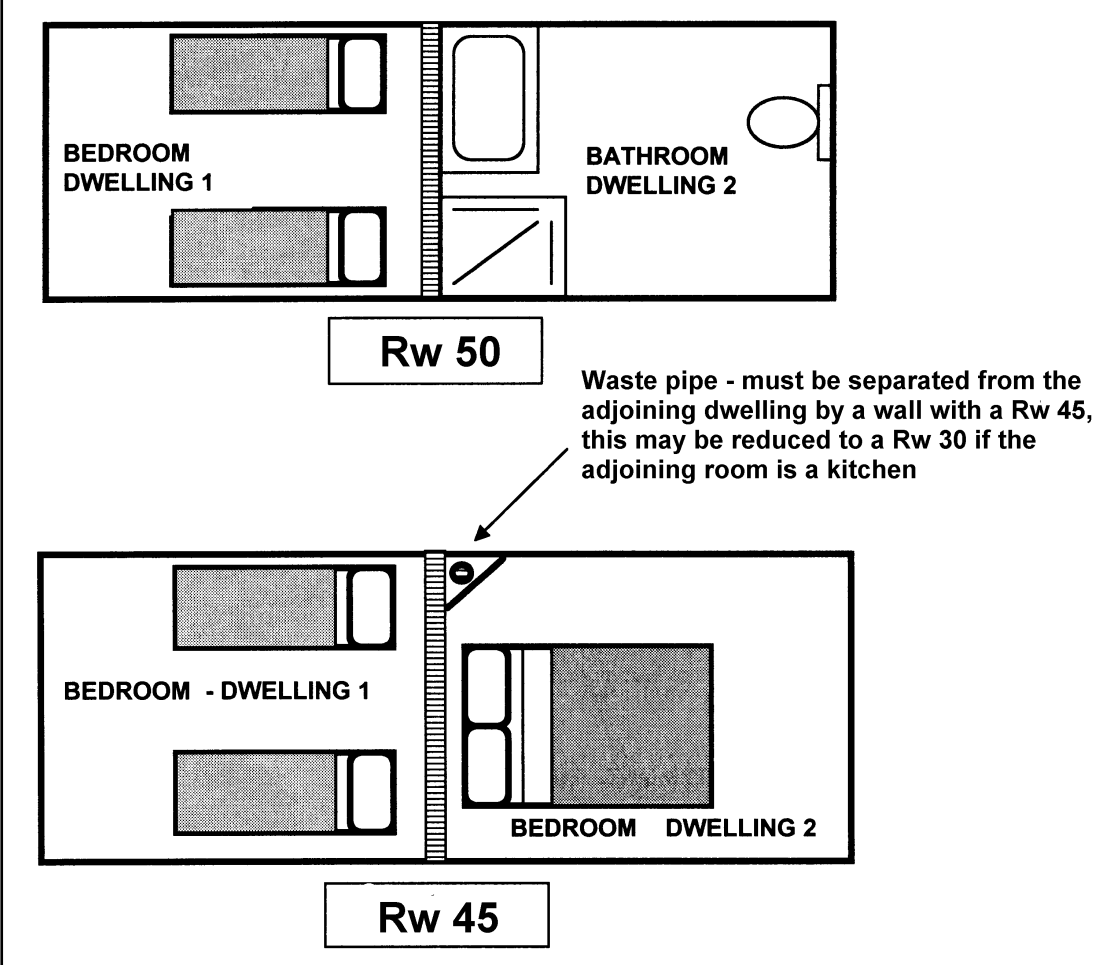

3.8.6.3 General installation requirements for walls

- (a) To achieve the appropriate R_w and impact sound resistance, walls must—
 - (i) be installed in accordance with the appropriate requirements contained in (b) to (f); and
 - (ii) at the junction of sound insulated walls with perimeter walls and roof cladding, be sealed in accordance with any relevant detail in [Figure 3.8.6.3](#).
- (b) Masonry units must—
 - (i) be laid with all joints filled solid, including those between the masonry and any adjoining construction; and
 - (ii) not be chased for services.
- (c) Joints between concrete slabs, wall units and any adjoining construction must be filled solid.
- (d) Plasterboard must be installed as follows:

- (i) If one layer is *required* under this Part, joints must be staggered with the joints in sheets on the opposite face of the wall.
- (ii) If 2 layers are *required*, the first layer must be fixed according to (i) and the second layer must be fixed to the first layer with nails, screws or adhesive so that the joints do not coincide with those of the first layer.
- (iii) Joints between sheets or between sheets and any adjoining construction must be taped and filled solid.
- (iv) Fire-protective grade plasterboard (when nominated) must be the grade manufactured for use in *fire-resisting* construction.

Figure 3.8.6.2

TYPICAL INSTALLATION OF PLASTER SHEETS FOR SOUND INSULATION

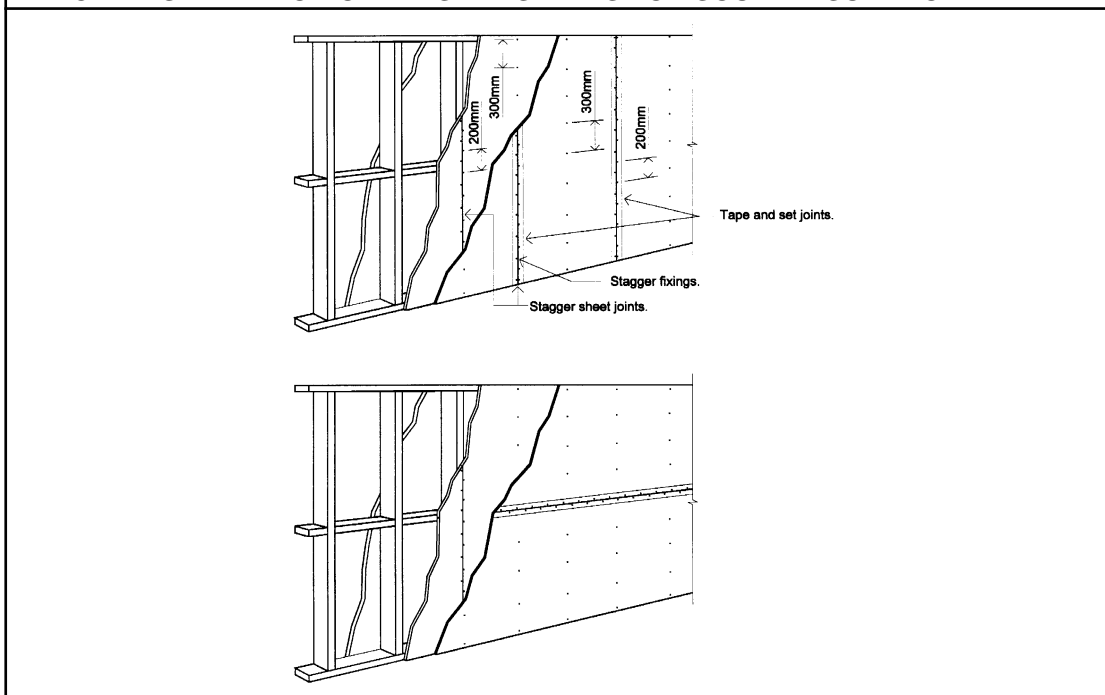

- (e) Steel studs and perimeter members must be installed as follows:
 - (i) The section of steel must be not less than 0.6 mm thick.
 - (ii) Studs must be not less than 63 mm in depth unless another depth is specified in the Table.
 - (iii) Studs must be fixed to steel top and bottom plates of sufficient depth to permit secure fixing of the plasterboard.
 - (iv) All steel members at the perimeter of the wall must be securely fixed to the adjoining structure and bedded in resilient compound or the joints must be caulked so that there are no voids between the steel members and the wall.

- (f) Timber studs and perimeter members must be installed as follows:
- (i) Studs must be fixed to top and bottom plates of sufficient depth to permit secure fixing of the plasterboard.
 - (ii) Noggings and like members must not bridge between studs supporting different wall leaves.
 - (iii) All timber members at the perimeter of the wall must be securely fixed to the adjoining structure and bedded in resilient compound or the joints must be caulked so there are no voids between the timber members and the wall.

3.8.6.4 Soil and waste pipes

If a soil or waste pipe passes through a *separating wall*—

- (a) a door or panel providing access to the pipe must not open into any *habitable room*, other than a kitchen; and
- (b) an access door or panel in any other part must be firmly fixed so as to overlap the frame or rebate of the frame by not less than 10 mm, be fitted with a sealing gasket along all edges and constructed of—
 - (i) wood, plasterboard or blockboard not less than 38 mm thick; or
 - (ii) compressed fibre reinforced cement sheeting not less than 9 mm thick; or
 - (iii) other suitable material with a mass per unit area not less than 24.4 kg/m².

Explanatory information:

The wall configurations shown in Tables 3.8.6.2 and 3.8.6.3 are typical examples. Other proprietary methods are available for meeting the R_w and sound impact levels required by Table 3.8.6.1.

Table 3.8.6.2	
CONSTRUCTION OF WALLS TO:	(A) REDUCE IMPACT SOUND; AND (B) ACHIEVE A 50 R_w
WALL CONSTRUCTION TYPE	DESIGN DIAGRAM—PLAN VIEW
<p>CAVITY BRICKWORK</p> <p>2 leaves 90 mm brick masonry with—</p> <ul style="list-style-type: none"> (a) all joints filled solid with mortar; and (b) an air space not less than 40 mm between the leaves; and (c) the leaves connected only by ties in accordance with AS 3700 and wall tie spacing details as set out in Part 3.3. 	

Table 3.8.6.2	
CONSTRUCTION OF WALLS TO:	(A) REDUCE IMPACT SOUND; AND (B) ACHIEVE A 50 Rw
WALL CONSTRUCTION TYPE	DESIGN DIAGRAM—PLAN VIEW
<p>SINGLE LEAF BRICKWORK</p> <p>80 mm thick brick masonry with—</p> <ul style="list-style-type: none"> (a) each face rendered 13 mm thick; and (b) 50x12 mm thick timber battens at not more than 610 mm centres fixed to each face but not recessed into the render; and (c) one layer of 12 mm thick softboard nailed to the battens; and (d) 6 mm thick medium density hardboard adhesive-fixed to the softboard. 	
<p>CONCRETE BLOCKWORK</p> <p>190 mm thick concrete block masonry with—</p> <ul style="list-style-type: none"> (a) each face of the blocks fitted with 50x50 mm timber battens, spaced at not more than 610 mm centres, screw-fixed into resilient plugs with rubber inserts; and (b) the space between the battens completely filled with mineral or glass wool blanket or batts not less than 50 mm thick; and (c) the outer face of the battens finished with plasterboard not less than 10 mm thick. 	
<p>TIMBER FRAMED WALLING</p> <p>70 x 45 mm F5 staggered timber studs at 600 mm centres both sides on 120 x 35 mm F5 timber plates with—</p> <ul style="list-style-type: none"> (a) one layer of 16 mm fire protective grade plasterboard on both faces; and (b) 50 mm glass fibre batts. 	

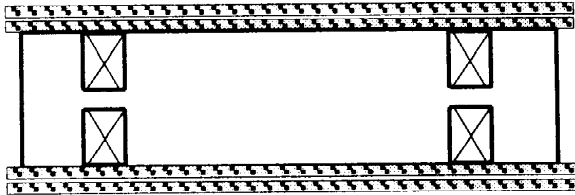
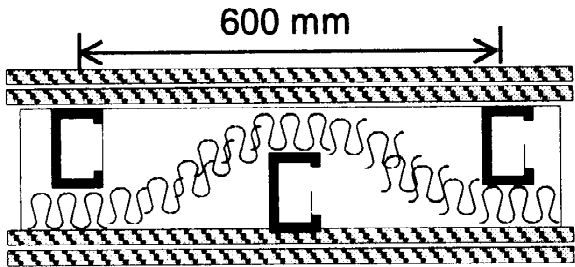
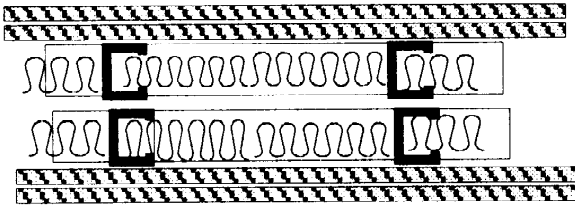

Table 3.8.6.2	
CONSTRUCTION OF WALLS TO:	(A) REDUCE IMPACT SOUND; AND (B) ACHIEVE A 50 Rw
WALL CONSTRUCTION TYPE	DESIGN DIAGRAM—PLAN VIEW
<p>TIMBER FRAMED WALLING</p> <p>70 x 45 mm F5 timber double studs at 450–600 mm centres with an air space not less than 20 mm between studs with two layers of 13 mm fire protective grade plasterboard on both faces.</p>	
<p>STEEL STUD WALLING</p> <p>64 mm staggered metal studs (0.75 mm base metal thickness) at 600 mm centres both sides, clipped in 92 mm metal tracks with—</p> <p>(a) two layers of 13 mm fire protective grade plasterboard to each side; and</p> <p>(b) 50 mm glasswool cavity batts.</p>	
<p>STEEL STUD WALLING</p> <p>64 mm double metal studs (0.75 mm base metal thickness) at 600 mm centres with an air space not less than 20 mm between studs, in separate frames with no mechanical links with—</p> <p>(a) two layers of 13 mm fire protective grade plasterboard to each side; and</p> <p>(b) 50 mm glasswool cavity batts.</p>	

Table 3.8.6.3		
Rw APPLICABLE TO CONSTRUCTION		
WALL CONSTRUCTION TYPE	Rw	DESIGN DIAGRAM—PLAN VIEW
<p>CLAY BRICKWORK</p> <p>(a) 110 mm thick in one or more leaves and with a mass per unit area of not less than 290 kg/m².</p>	45	
<p>(b) 80 mm thick, pressed brick and rendered 13 mm on one side, the mass per unit area of the unrendered wall being not less than 215 kg/m².</p>	45	

CALCIUM SILICATE BRICKWORK

(a) 90 mm thick calcium silicate brick with one layer of 10 mm fire protective grade plasterboard on each side.

45

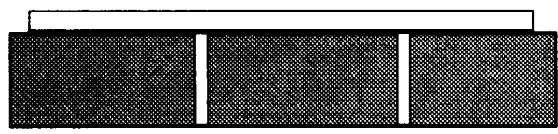
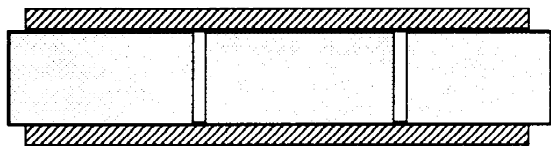

(b) 90 mm thick calcium silicate brick with one layer of 10 mm fire protective plasterboard and one layer of fire protective plasterboard on metal furring channels.

45

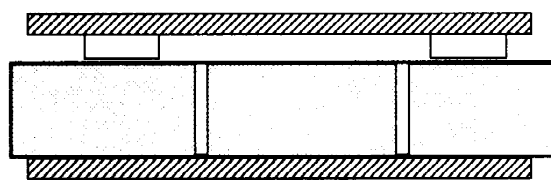

CONCRETE BLOCKWORK

(a) 190 mm solid units (or thicker)
Material density 2200 kg/m³

45



(b) 110 mm solid units (or thicker)
Material density 2200 kg/m³
Material thickness—83 mm min.
10 mm plasterboard or 12 mm render on each face.

45

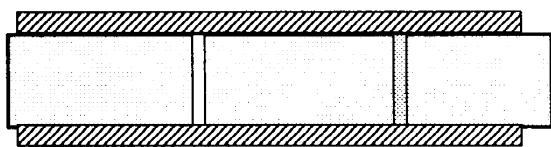

CONCRETE WALL

In-situ concrete—125 mm thick and with a density of not less than 2200 kg/m³.

45



STEEL STUD WALLING

(a) With 2 layers of 16 mm thick fire-protective grade plasterboard fixed to each face.

45

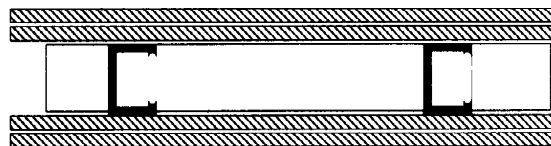

(b) With 2 layers of 13 mm plasterboard on both sides of 75 mm studs.

45

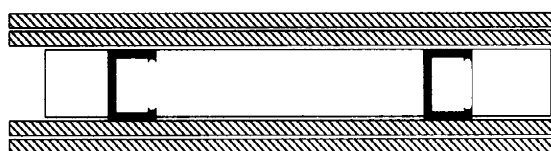

TIMBER STUD WALLING

70 x 45 mm timber studs at 450–600 mm centres with—

49

- (a) one layer of 16 mm fire protective grade plasterboard on one face; and
- (b) 50 mm glass fibre batts; and
- (c) one layer of 16 mm fire protective grade plasterboard on metal resilient channel.

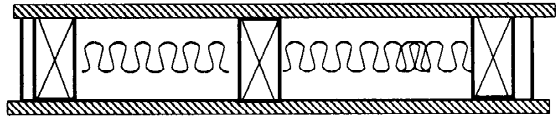

70 x 45 mm timber studs at 450–600 mm centres with two layers of 16 mm fire protective grade plasterboard on both sides.

46

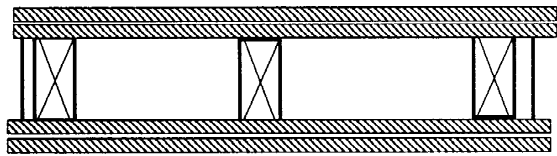

DUCTS OR OTHER CONSTRUCTION SEPARATING SOIL AND WASTE PIPES FROM UNITS

MASONRY—

Not less than 90 mm thick.

30



PLASTERBOARD—

- (a) 2 layers of plasterboard each 10 mm thick, fixed to timber studs not less than 75 mm x 50 mm and spaced at not more than 400 mm centres.

30

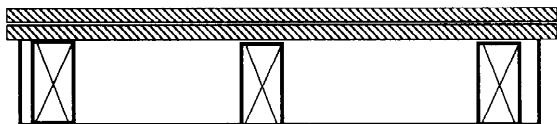

- (b) 2 layers of plasterboard each 13 mm thick, one on each side of steel studs not less than 50 mm deep and spaced at not more than 400 mm centres.

30



Figure 3.8.6.3

SOUND INSULATION BETWEEN UNITS — DOUBLE STUD WALL CONFIGURATION

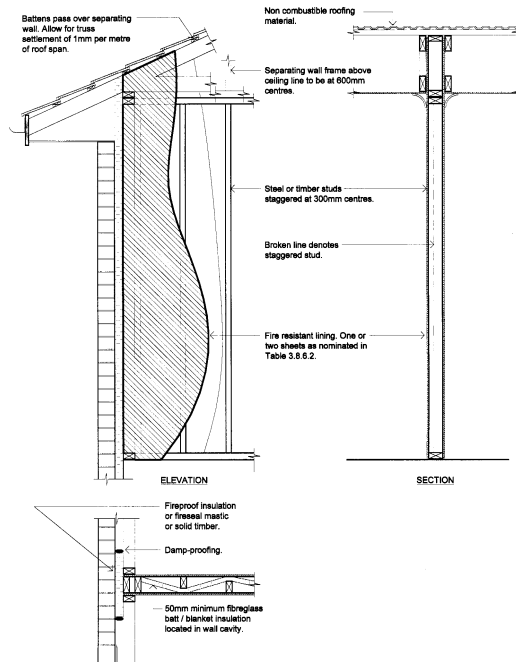

PART **3.9**

SAFE MOVEMENT AND ACCESS

- 3.9.1 Stair Construction**
- 3.9.2 Balustrades**
- 3.9.3 Swimming Pool Access**

PART 3.9 CONTENTS

PART 3.9 SAFE MOVEMENT AND ACCESS

3.9.1 Stair construction

- 3.9.1 Definitions
- 3.9.1.1 Application
- 3.9.1.2 General requirements
- 3.9.1.3 Stair construction
- 3.9.1.4 Riser and going dimensions
- 3.9.1.5 Threshold

3.9.2 Balustrades

- 3.9.2.1 Application
- 3.9.2.2 When balustrades or other barriers are required
- 3.9.2.3 Balustrades or other barrier construction

3.9.3 Swimming pool access

- 3.9.3.0 Acceptable construction manual
- 3.9.3.1 Application
- 3.9.3.2 Safety fencing location
- 3.9.3.3 Safety fencing construction
- 3.9.3.4 Gates and fittings

PART 3.9.1 STAIR CONSTRUCTION

Appropriate Performance Requirements

Where an alternative stair system is proposed as an *Alternative Solution* to that described in Part 3.9.1, that proposal must comply with—

- (a) Performance Requirement **P2.5.1**; and
- (b) the relevant Performance Requirements determined in accordance with **1.0.10**.

Definitions

3.9.1

The following definitions are used in this Part:

Flight means that part of a stair that has a continuous series of *risers*, including *risers* of *winders*, not interrupted by a *landing* or floor (see **Figure 3.9.1.1**).

Explanatory information:

A *flight* is the area of a stair that has a continuous slope created by the nosing line of treads. The length of a *flight* is limited to restrict the distance a person could fall down a stair. Quarter *landings*, as shown in **Figure 3.9.1.1**, are considered sufficient to halt a person's fall and therefore are considered for the purposes of this document not to be part of the *flight*.

Figure 3.9.1.1

IDENTIFICATION OF STAIR FLIGHTS — Plan view

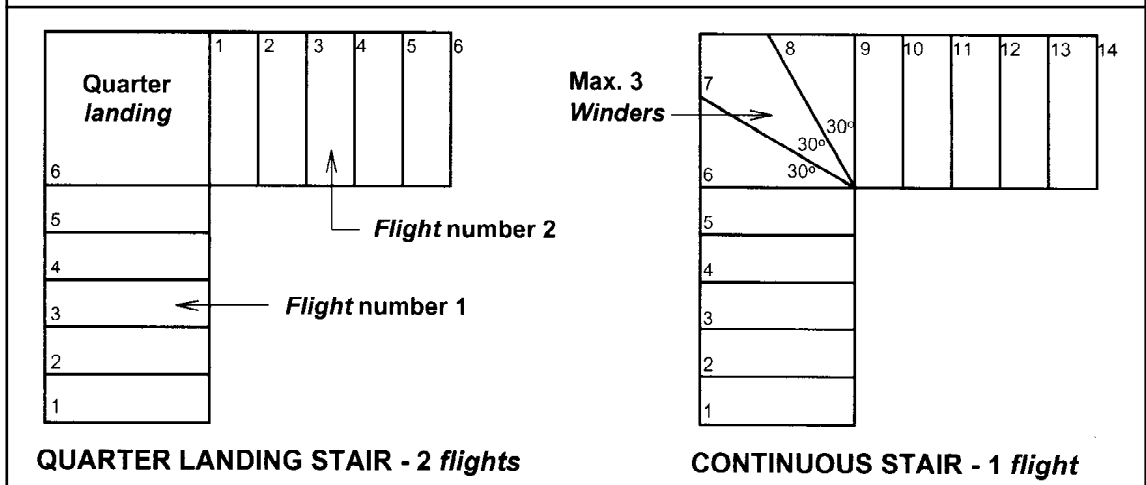

Going means the horizontal dimension from the front to the back of a tread less any overhang from the next tread above (see [Figure 3.9.1.2](#)).

Landing means an area at the top or bottom of a *flight* or between two *flights*.

Riser means the height between consecutive treads.

Spiral stair means a stair with a circular plan, winding around a central post with steps that radiate from a common centre or several radii (see [Figure 3.9.1.4](#)).

Tapered tread means a stair tread with a walking area that grows smaller towards one end.

Winders means treads within a straight *flight* that are used to change direction of the stair (see [Figure 3.9.1.1](#)).

Acceptable construction practice

3.9.1.1 Application

Compliance with this Part satisfies *Performance Requirement P2.5.1*, provided the stair complies with the appropriate structural requirements of the *Housing Provisions*.

3.9.1.2 General requirements

- (a) Stairs serving *habitable rooms*, including external stairs must comply with [3.9.1.3](#) and [3.9.1.4](#).
- (b) Stairs serving only *non-habitable rooms*, such as attics, storerooms and the like that are not used on a regular or daily basis, must be constructed in accordance with—
 - (i) the provisions of this Part; or
 - (ii) AS 1657—Fixed platforms, walkways, stairways and ladders.

3.9.1.3 Stair construction

Stairs must be constructed in accordance with the following:

- (a) Each *flight* must have not more than 18 nor less than 2 *risers*.
- (b) The nominal dimension of *goings* and *risers* of a stair must be constant throughout each stair *flight* except that the *going* of *winders* in lieu of a quarter or half *landing* may vary from the *going* of the straight treads within the same *flight* provided that the *going* of all such *winders* is constant.
- (c) Treads must be of solid construction (not mesh or other perforated material) if the stairway is more than 10 m high or connects more than 3 storeys.
- (d) A *flight* of stairs must not have more than 3 *winders* in lieu of each quarter *landing* or 6 *winders* in lieu of each half *landing*.
- (e) The *riser* opening must not allow a 125 mm sphere to pass through between the treads.
- (f) * * * * *
- (g) Treads must have a non-slip finish or a suitable non-skid strip near the edge of the nosings.
- (h) *Landings* must—

- (i) be not less than 750 mm long and where this involves a change in direction, the length is measured 500 mm from the inside edge of the *landing* (see [Figure 3.9.1.5](#), Diagram a); and
- (ii) have a gradient not steeper than 1:50; and
- (iii) be provided where the sill of a threshold of a doorway opens on to a stair that provides a change in floor level or floor to ground level greater than 3 *risers* or 570 mm (see [Figure 3.9.1.5](#), Diagram b).

3.9.1.4 Riser and going dimensions

The *riser* and *going* dimensions for each *flight*, except for the *going* of *winders* in lieu of a quarter or half *landing*, must comply with the following:

- (a) The *going* (G), *riser* (R) and slope relationship quantity (2R+G) must be in accordance with [Figure 3.9.1.2](#).
- (b) The point for measurement of the *going* (G) in the slope relationship quantity as described in [Figure 3.9.1.3](#) must be—
 - (i) for *tapered treads* (other than treads in a *spiral stair*)—
 - (A) not more than 1 m wide, the middle of the unobstructed width of the stair (see [Figure 3.9.1.3](#), Diagram b) and
 - (B) more than 1 m in width, 400 mm from the unobstructed width of each side of the stair (see [Figure 3.9.1.3](#), Diagram c); and
 - (ii) for treads in *spiral stairs*, the point seven tenths of the unobstructed distance from the face of the centre pole or support towards the handrail side (see [Figure 3.9.1.4](#)).

Figure 3.9.1.2

STAIR RISER AND GOING DIMENSIONS (mm)

STAIR TYPE	RISER (R)		GOING (G)		SLOPE RELATIONSHIP	
	(see Figure below)		(see Figure below)		(2R+G)	
	Max	Min	Max	Min	Max	Min
Stairs (other than spiral)	190	115	355	240	700	550
Spiral	220	140	370	210	680	590

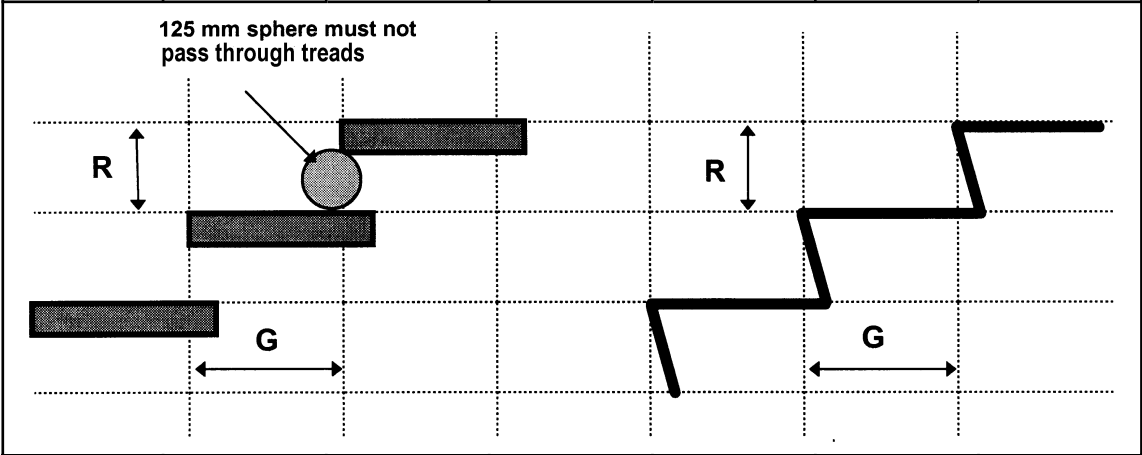

Figure 3.9.1.3

MEASUREMENT OF SLOPE RELATIONSHIP—Plan view

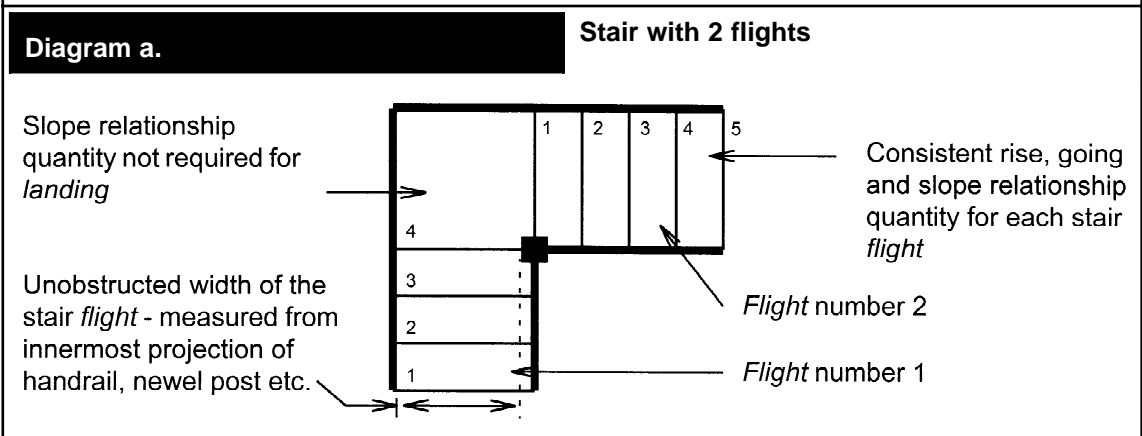

Figure 3.9.1.3

MEASUREMENT OF SLOPE RELATIONSHIP—Plan view

Diagram b.

Tapered treads—less than 1 m wide

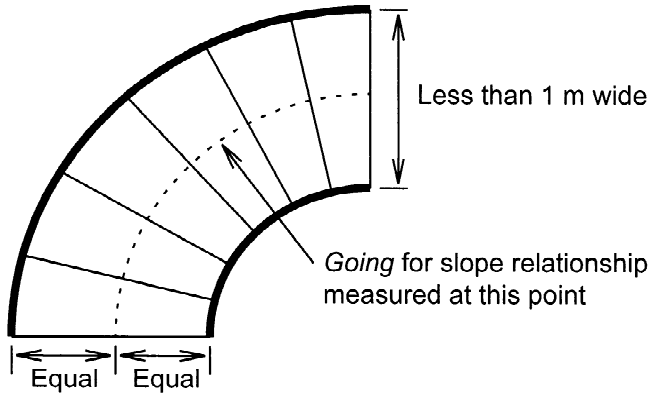

Diagram c.

Tapered treads—1 m or more in width

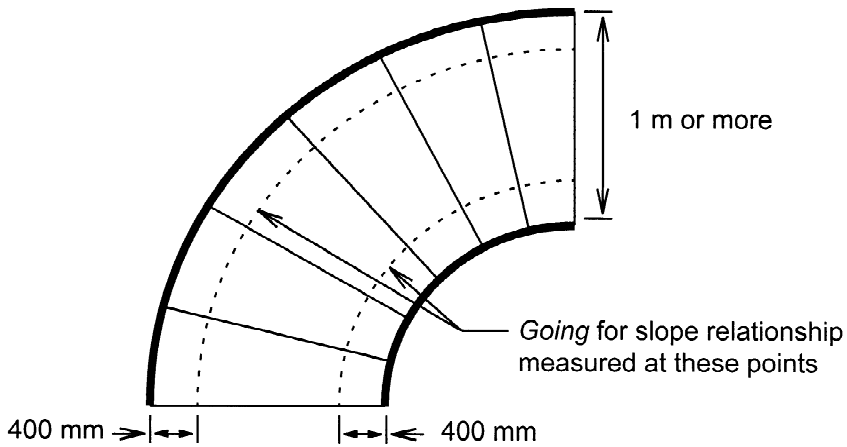

Figure 3.9.1.4
SPIRAL STAIRS

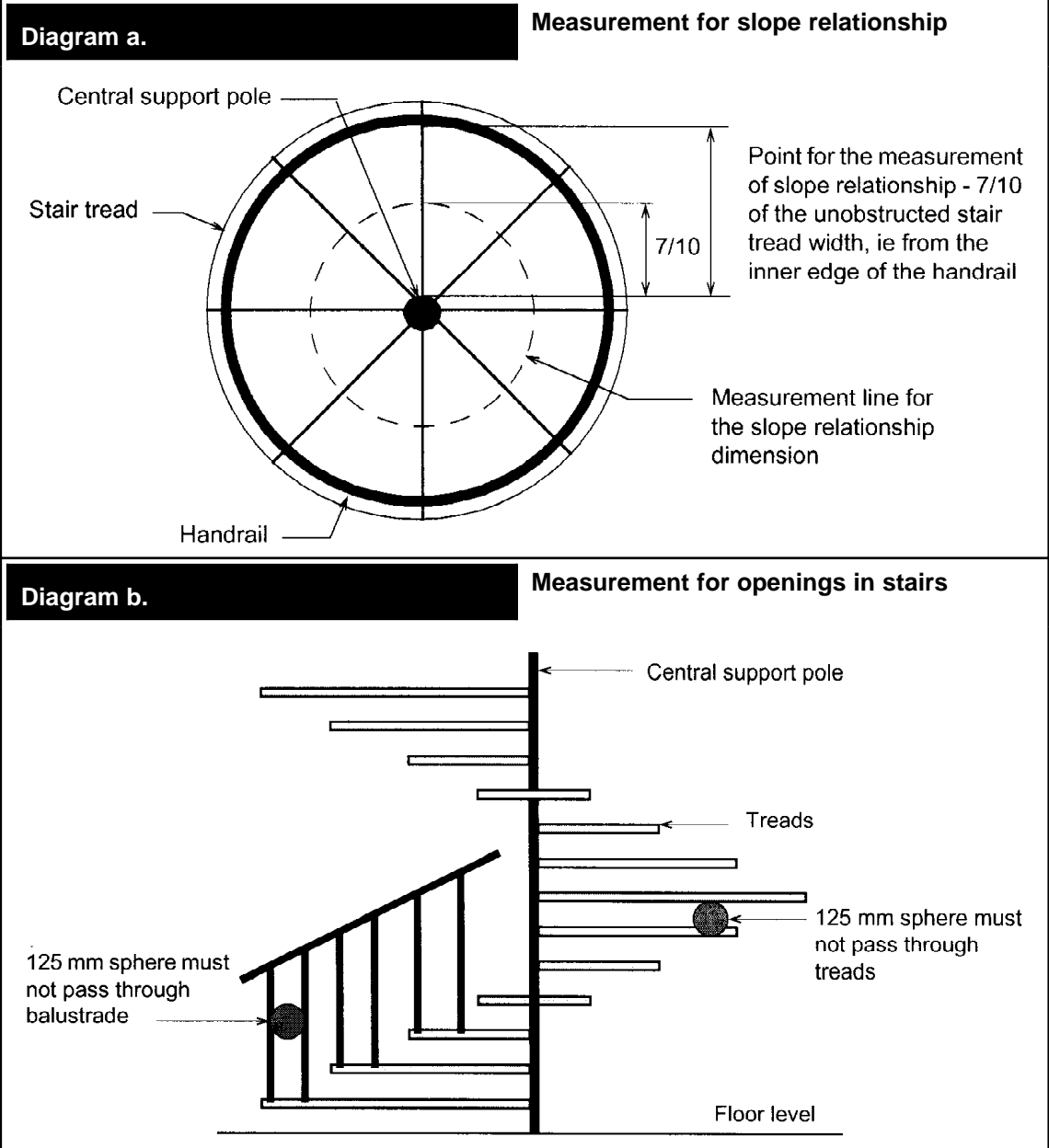

Figure 3.9.1.5

LANDINGS

Diagram a.

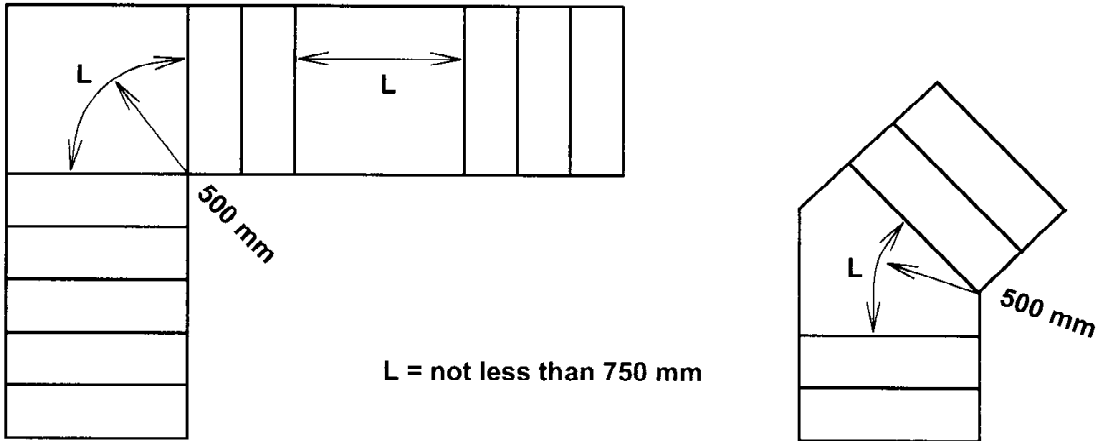
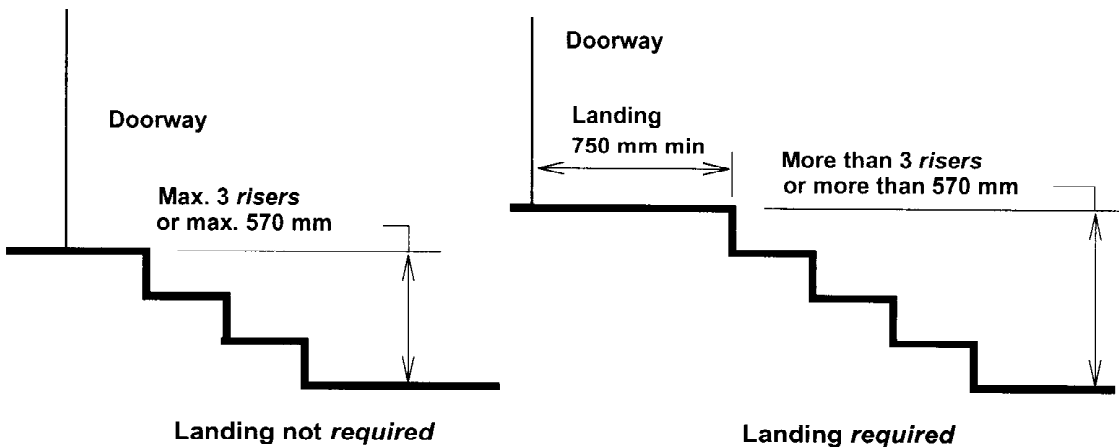

Diagram b.



3.9.1.5 Thresholds

Where a threshold is more than 190 mm above the adjoining surface it must incorporate steps having *riser* and *going* dimensions in accordance with [3.9.1.4](#).

PART 3.9.2 BALUSTRADES

Appropriate Performance Requirements

Where an alternative balustrade or other barrier is proposed as an *Alternative Solution* to that described in Part 3.9.2, that proposal must comply with—

- (a) Performance Requirement **P2.1**; and
- (b) Performance Requirement **P2.5.2**; and
- (c) the relevant *Performance Requirements* determined in accordance with **1.0.10**.

Acceptable construction practice

3.9.2.1 Application

Compliance with this Part satisfies *Performance Requirement P2.5.2* for balustrades or other barriers.

3.9.2.2 When balustrades or other barriers are required

- (a) A continuous balustrade or other barrier must be provided along the side of any roof to which public access is provided, any stairway or ramp, any floor, corridor, hallway, balcony, verandah, mezzanine, access bridge or the like and along the side of any path of access to a building, if—
 - (i) it is not bounded by a wall; and
 - (ii) any level is more than 1 m above the surface beneath (see **Figure 3.9.2.3**).
- (b) The requirements of (a) do not apply to a *window* opening.

3.9.2.3 Balustrades or other barrier construction

- (a) The height of a balustrade or other barrier must be in accordance with the following:
 - (i) The height must not be less than 865 mm above the nosings of the stair treads or the floor of a ramp.
 - (ii) The height must not be less than—
 - (A) 1 m above the floor of any access path, balcony, *landing* or the like (see **Figure 3.9.2.1**); or
 - (B) 865 mm above the floor of a *landing* to a stair or ramp where the balustrade or other barrier is provided along the inside edge of the *landing* and is not more than 500 mm long.
- (b) A transition zone may be incorporated where the balustrade or other barrier height changes from 865 mm on the stair *flight* or ramp to 1 m at the *landing* (see **Figure 3.9.2.2**).

- (c) Openings in balustrades (including decorative balustrades) or other barriers must be constructed so that any opening does not permit a 125 mm sphere to pass through it and for stairs, the space is tested above the nosing line.
- (d) A balustrade or other barrier must be designed to take loading forces in accordance with AS 1170.1 or AS/NZS 1170.1.
- (e) For floors more than 4 m above the surface beneath, any horizontal elements within the balustrade or other barrier between 150 mm and 760 mm above the floor must not facilitate climbing.

Figure 3.9.2.1

BALUSTRADE OR OTHER BARRIER CONSTRUCTION

Note:

For the purposes of this Figure, a 125 mm sphere must not pass between rails or through the gap when tested above the nosing line.

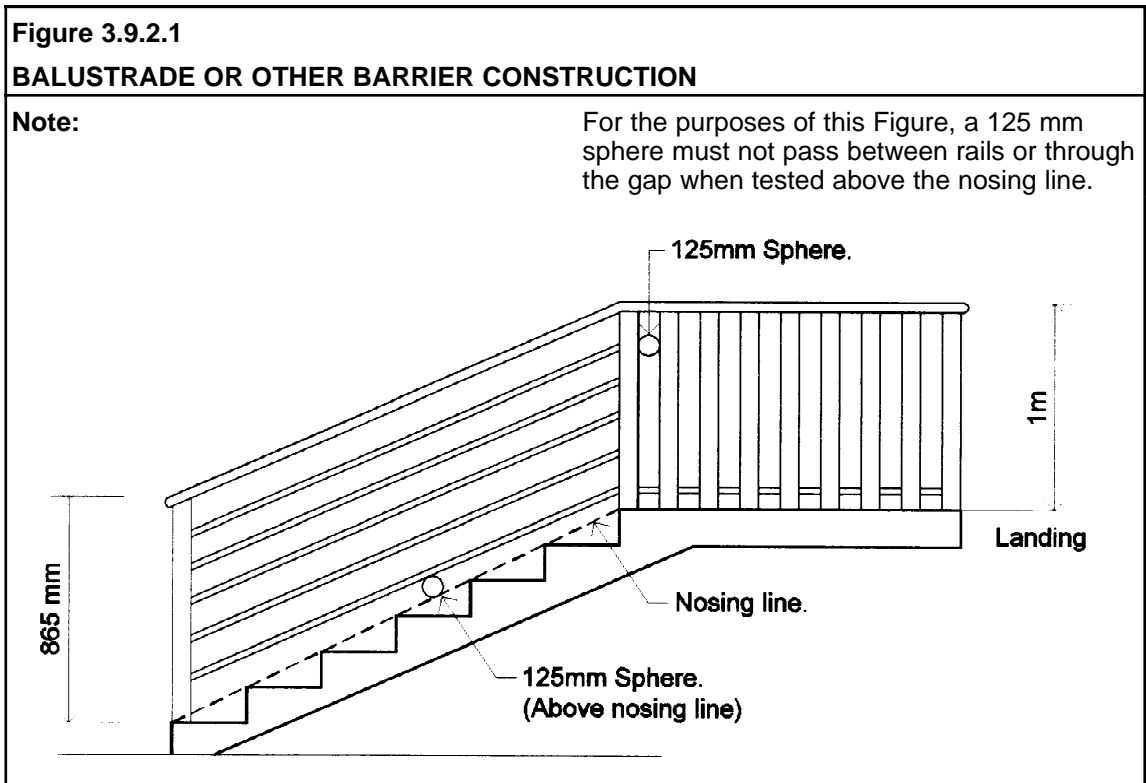

Figure 3.9.2.2
TRANSITION ZONES

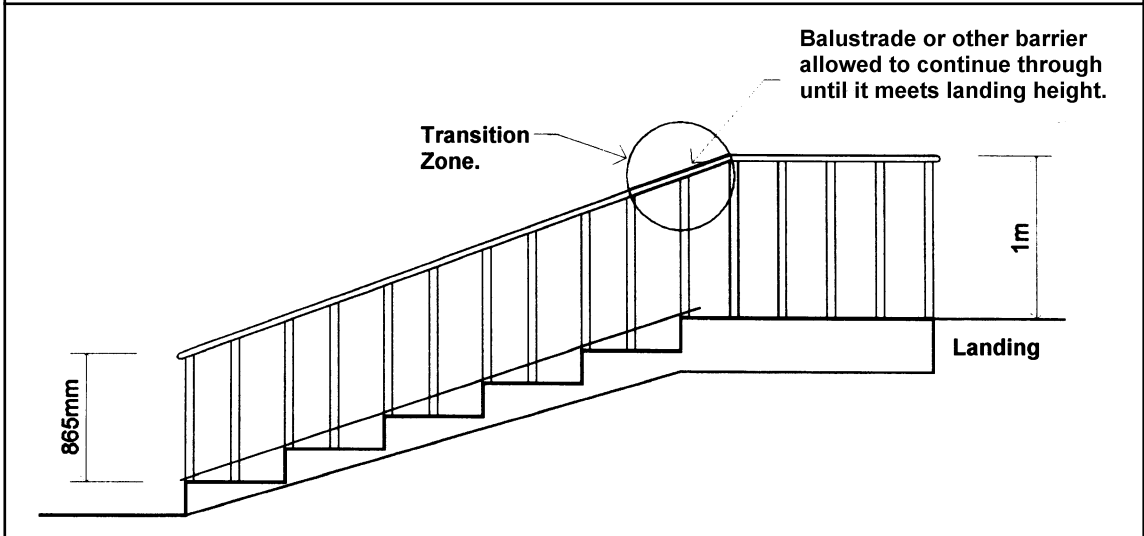
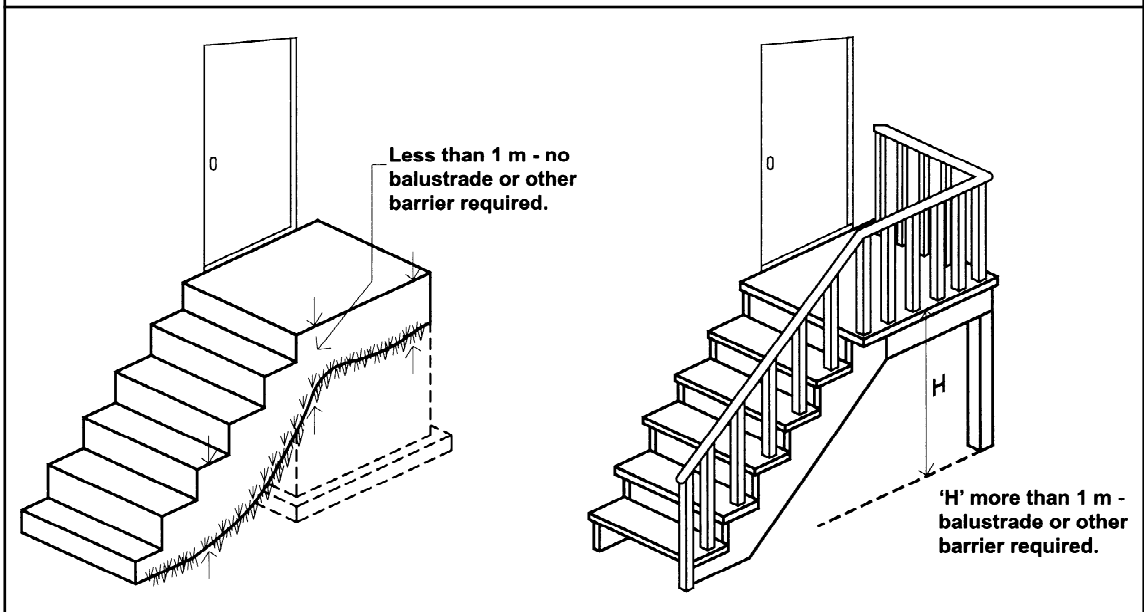

Figure 3.9.2.3
BALUSTRADES OR OTHER BARRIERS—WHEN REQUIRED



PART 3.9.3 SWIMMING POOL ACCESS

Appropriate Performance Requirements

Where an alternative *swimming pool* safety fence is proposed as an *Alternative Solution* to that described in Part 3.9.3, that proposal must comply with—

- (a) *Performance Requirement* **P2.5.3**; and
- (b) the relevant *Performance Requirements* determined in accordance with **1.0.10**.

STATE AND TERRITORY VARIATIONS

1. Part 3.9.3 does not apply in New South Wales.

Notes: 1. Restriction of access to *swimming pools* in New South Wales is regulated under the Swimming Pools Act 1992.

2. See NSW 1 for additional requirements for *swimming pool* construction.

2. Part 3.9.3 does not apply in Queensland.

Note: Restriction of access to *swimming pools* in Queensland is regulated under the Building Act 1975.

3. Part 3.9.3 does not apply in Western Australia.

Note: Restriction of access to private *swimming pools* in Western Australia is regulated under the Local Government (Miscellaneous Provisions) Act 1960 and the Building Regulations 1989 as amended.

4. Part 3.9.3 does not apply in the Northern Territory.

A. Acceptable construction manual

3.9.3.0

Performance Requirement **P2.5.3** is satisfied for a *swimming pool* associated with a Class 1 building, with a depth of water more than 300 mm if it has safety fencing installed in accordance with AS 1926.1—Swimming pool safety.

B. Acceptable construction practice

3.9.3.1 Application





Compliance with this Part satisfies *Performance Requirement* **P2.5.3** for *swimming pools* with a depth of water more than 300 mm, installed on allotments associated with Class 1 buildings.

3.9.3.2 Safety fencing location

- (a) Safety fencing must be located in accordance with one of the options shown in [Figure 3.9.3.1](#).
- (b) The location of safety fencing must ensure that the effective fencing height is not reduced by nearby objects or projections (see [Figure 3.9.3.4](#)).

Figure 3.9.3.1

TYPICAL EXAMPLES OF SAFETY FENCING

Legend:			
	Gate complying with AS 1926.1		Fence, retaining wall or other barrier complying with AS 1926.1
	Child resistant door or window complying with AS 1926.1		Allotment boundary

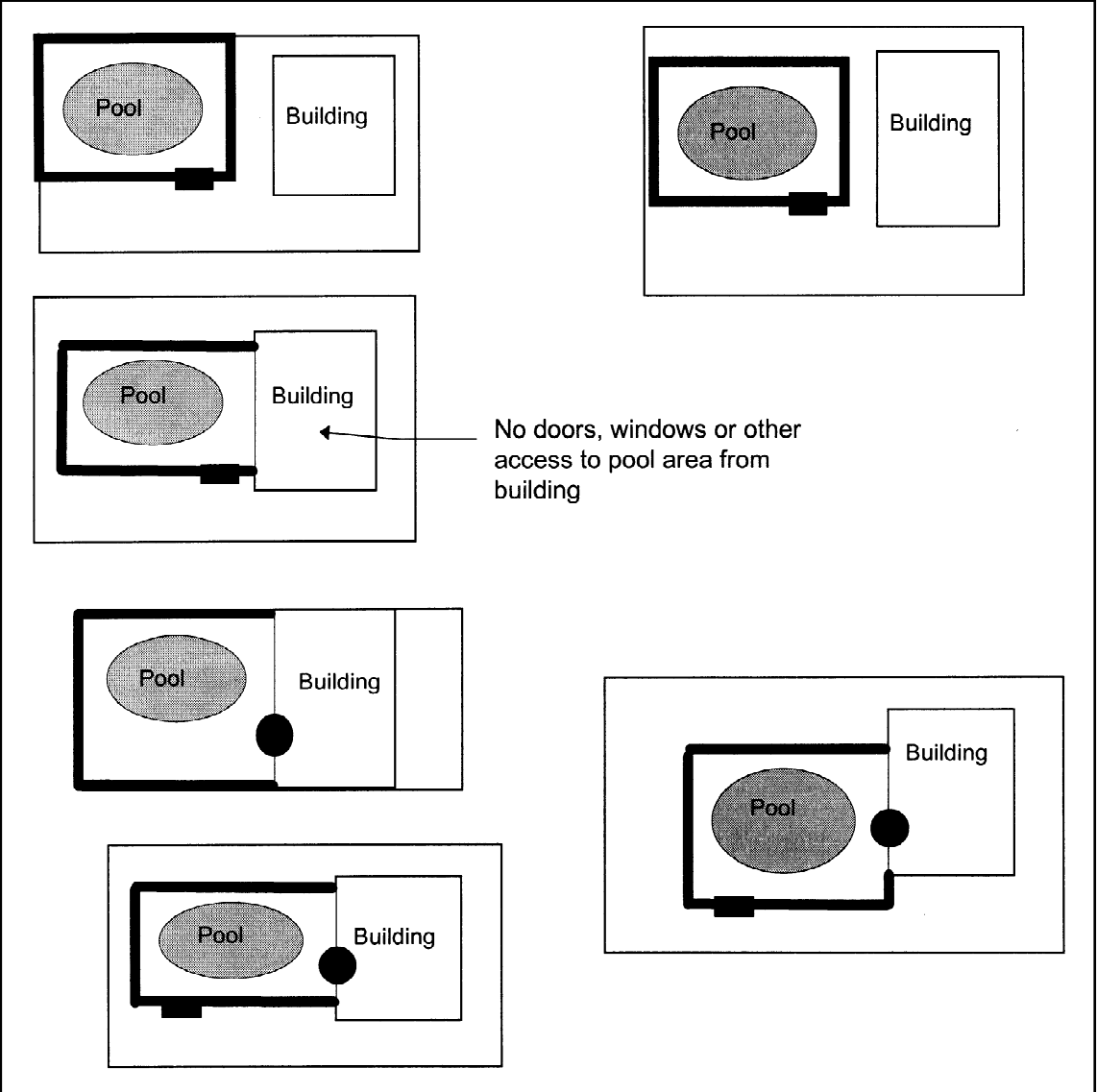

3.9.3.3 Safety fencing construction

Safety fences and gates must comply with the following:

- (a) The strength and rigidity of fencing components and elements must comply with AS 1926.1.
- (b) The effective height of fencing must be not less than 1.2 m, except for fencing constructed of perforated or mesh material with apertures more than 13 mm but less than 100 mm, in which case the effective height must be not less than that shown in [Figure 3.9.3.3](#).
- (c) Retaining walls or other similar barriers which form part of the safety fencing must comply with [Figure 3.9.3.5](#).
- (d) The clearance between the bottom of the fencing and the finished ground level must not be more than 100 mm.
- (e) Projections or indentations on the outside surface of the fencing must not exceed the dimensions shown in [Figure 3.9.3.2\(a\)](#).
- (f) Horizontal or near horizontal fencing components, such as rails, rods, wires or bracing, that could be used as holds for climbing must—
 - (i) if located on the outside of the fencing; or
 - (ii) if located on the inside of the fencing and the vertical members are spaced more than 10 mm apart;be spaced in accordance with [Figure 3.9.3.2](#).
- (g) The clear gap between adjacent vertical or near vertical members must not be more than 100 mm.

Figure 3.9.3.2

SPACING OF ACCESSIBLE HORIZONTAL MEMBERS, PROJECTIONS OR INDENTATIONS IN FENCING

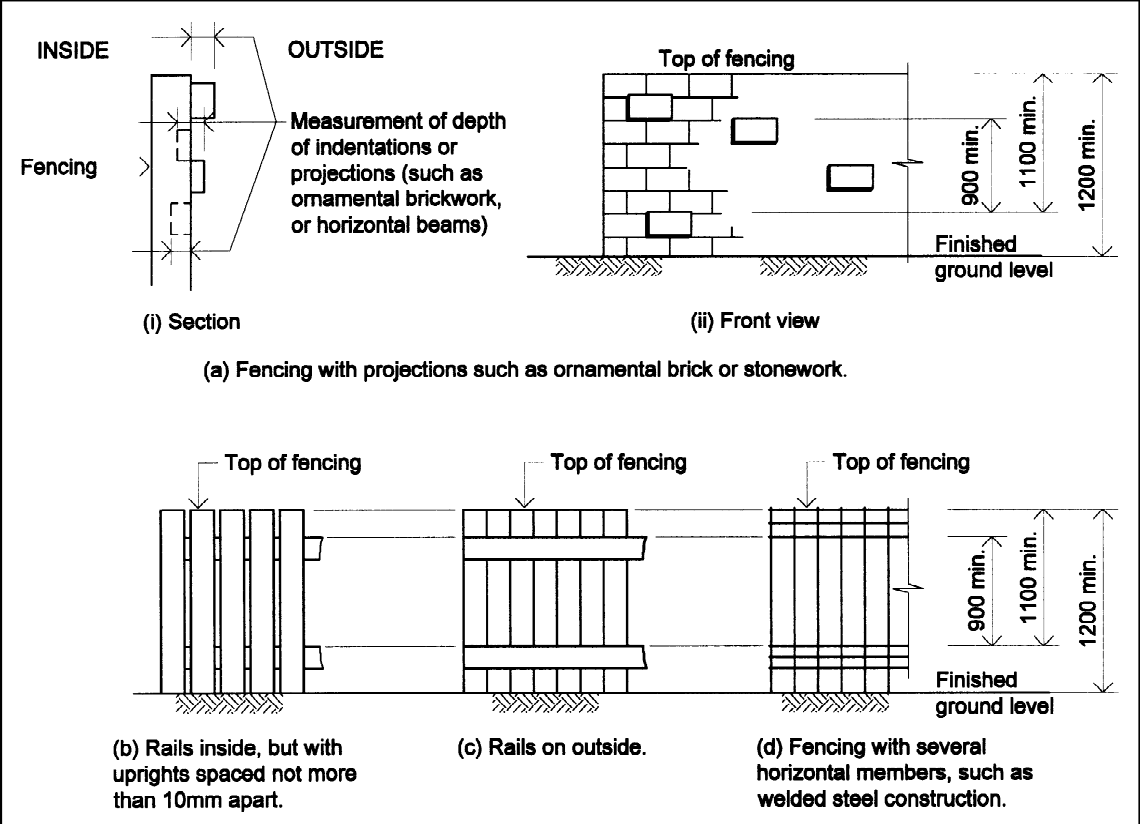

Figure 3.9.3.3

CHAIN WIRE OR MESH FENCE

Note: Fencing material with an aperture more than 13 mm, but less than 100 mm.

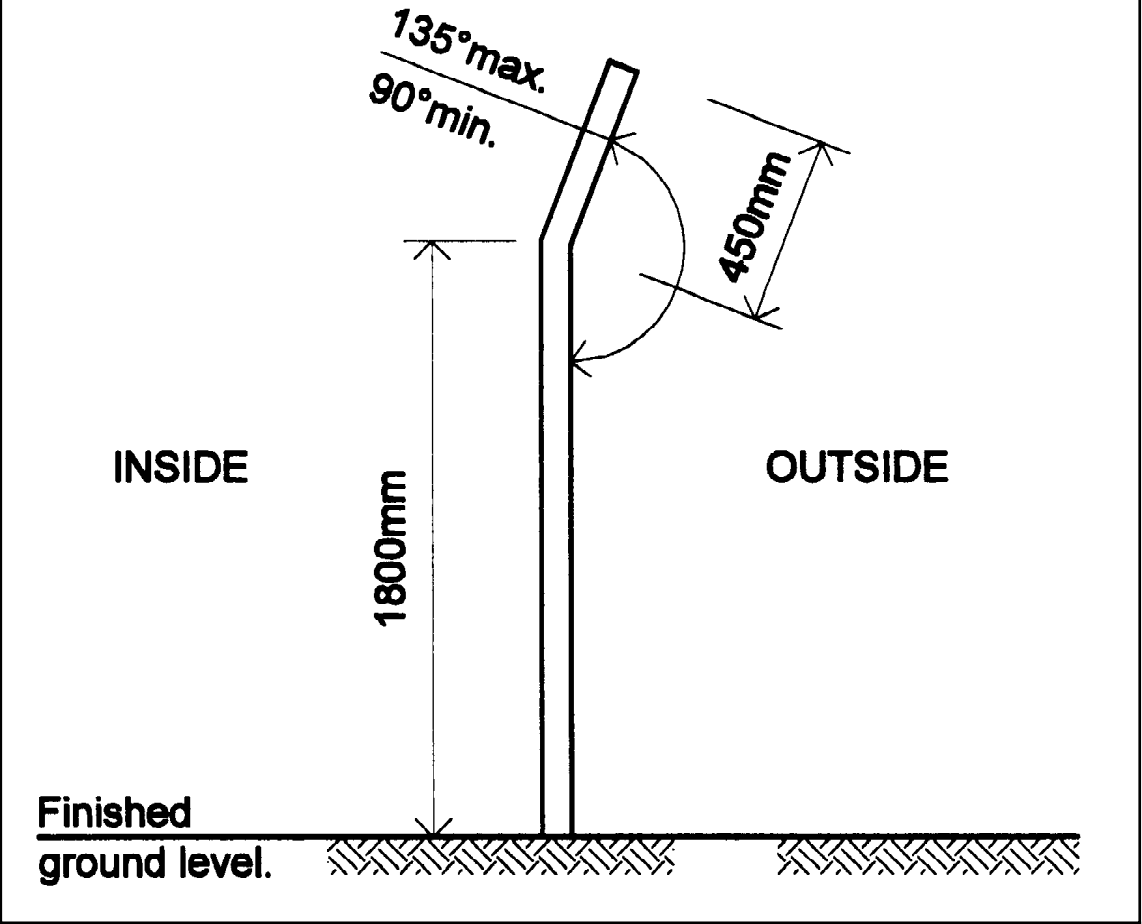

Figure 3.9.3.4

EFFECTIVE FENCING HEIGHT

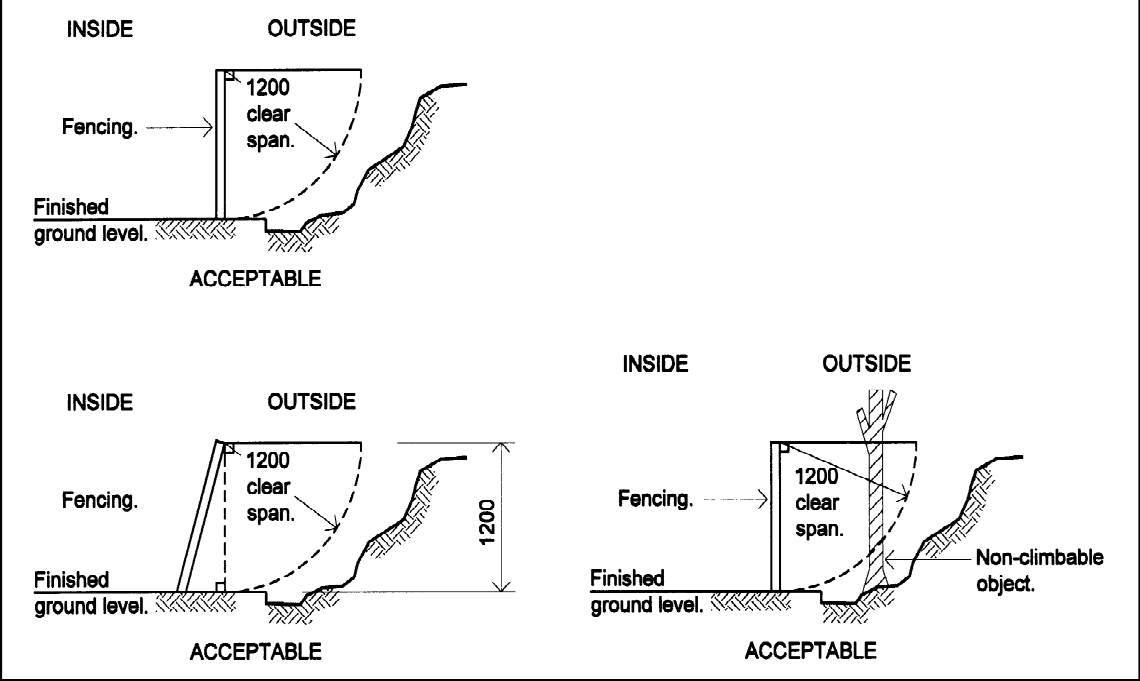
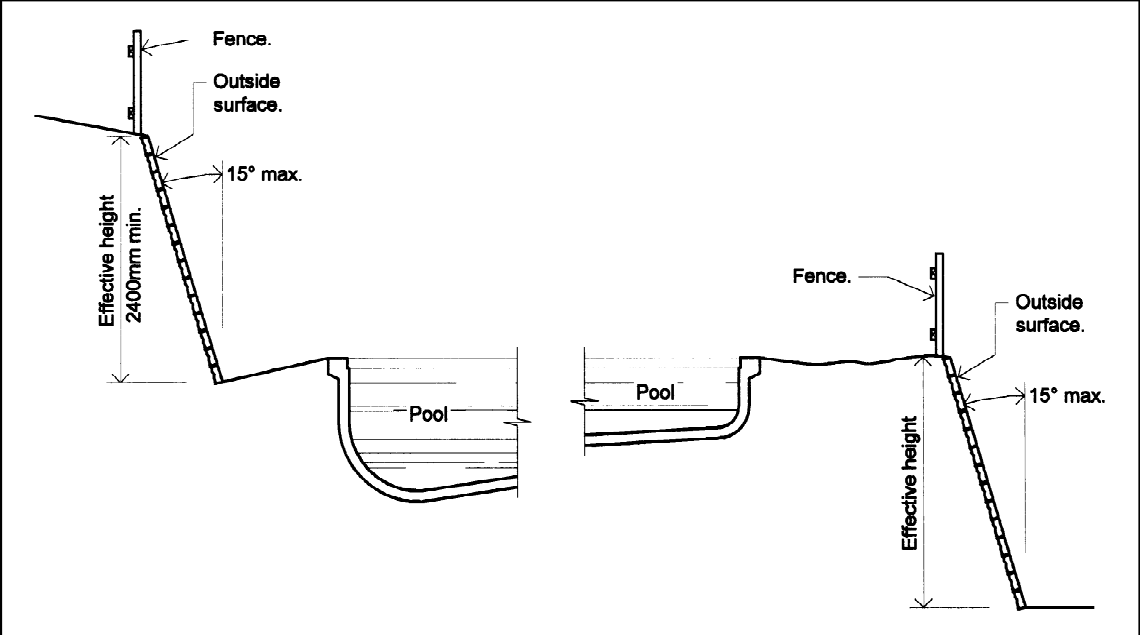

Figure 3.9.3.5

RETAINING WALLS AND OTHER SUCH BARRIERS



3.9.3.4 Gates and fittings

Gates and fittings must comply with the relevant requirements of 3.9.3.2 and the following:

- (a) Gates must swing outwards from the pool area.
- (b) Gates must be fitted with a self closing device that will return the gate to the closed position and operate the latching device—
 - (i) from any position from resting on the latching mechanism to fully open; and
 - (ii) from a stationary start without the application of a manual force.
- (c) Gates must be fitted with a latching device—
 - (i) that will automatically operate on the closing of the gate and prevent the gate from being re-opened without manual release; and
 - (ii) that cannot be inadvertently adjusted in operation or adjusted without the use of tools; and
 - (iii) located and shielded in accordance with one of the options shown in [Figure 3.9.3.7](#).

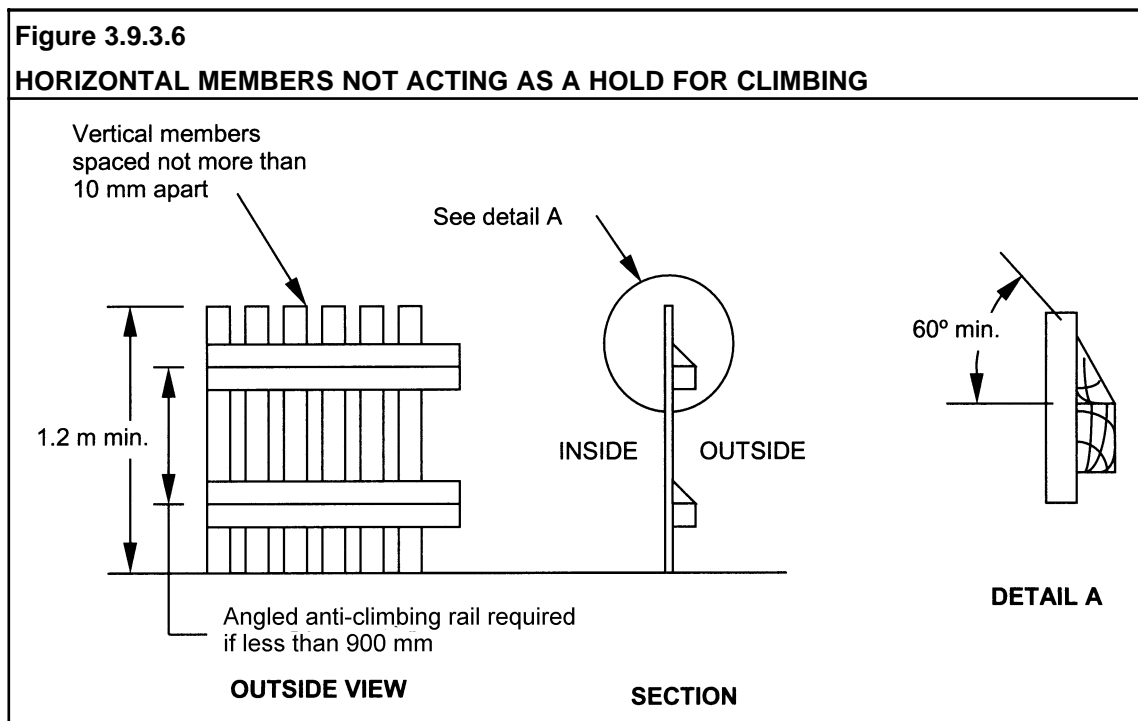
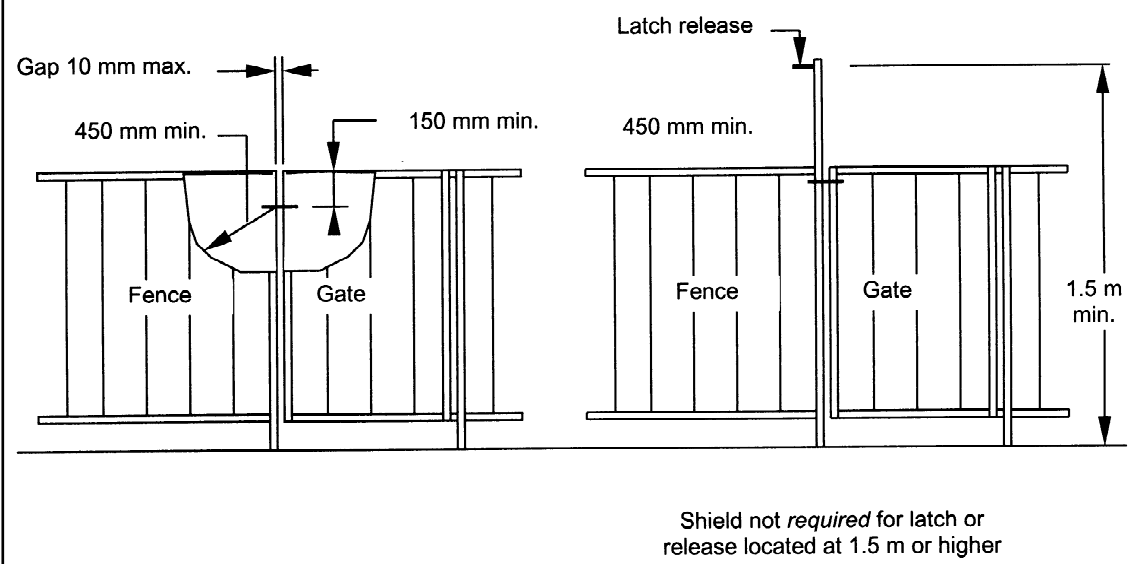

Figure 3.9.3.7

LOCATION AND SHIELDING OF GATE LATCHES



Explanatory information:

Safety fencing should consist of barriers or walls of sufficient height and designed and constructed without openings and footholds that would enable a young child to climb through or over the fence and provided with child-resistant self-closing and latching devices on gates and doors and if incorporating an external wall of a building, any doors and openable windows to the pool area should be fitted with self-closing and latching devices that are child-resistant.

It should be noted that in NSW, Qld, WA and NT restriction of access to *swimming pools* is regulated under other legislation. ACT, Qld, SA and Tas impose additional requirements for *swimming pools* which may include provisions affecting the design of pools and pool surrounds, drainage of *swimming pools*, water recirculation and inlet and outlet openings and skimmer boxes and electrical installations.

The provisions of AS 1926.2 provide a number of options for the location of pool safety fencing. One option consists of enclosing the pool with isolation safety fencing completely separating the pool area from any other part of the allotment and any buildings. Alternatively the pool area should be separated from other parts of the allotment, any buildings and neighbouring allotments with barriers complying with the standards for safety fencing including the external wall of a building provided there is no access from the building to the pool area.

If access is provided from the building to the pool area any access door and window opening to the pool area must be protected with child-resistant doorsets and child-resistant openable portions of window.

Swimming pool safety fencing should be designed and constructed so as to be non-climbable by young children having regard to the height of the fence, any horizontal climbable members, openings and footholds in the fence and the operation of self-closing and latching gates.

Typical examples of satisfactory safety fencing are illustrated in AS 1926.1.

STATE AND TERRITORY VARIATIONS

See ACT 6 for additional requirements for *swimming pool construction*.

See NSW 1 for additional requirements for *swimming pool construction*.

See SA 4 for additional requirements for *swimming pool construction*.

See TAS 2 for additional requirements for *swimming pool construction*.

PART **3.10**

ADDITIONAL CONSTRUCTION REQUIREMENTS

3.10.1 High Wind Areas

3.10.2 Earth Quake Areas

PART 3.10 CONTENTS

PART 3.10 ADDITIONAL CONSTRUCTION REQUIREMENTS

Explanatory Information

3.10.1 High Wind Areas

3.10.1.0 Acceptable construction manual

3.10.2 Earthquake Areas

3.10.2 Definitions

3.10.2.0 Acceptable construction manuals

3.10.2.1 Application

3.10.2.2 Construction requirements

3.10.2.3 Construction for areas with an acceleration coefficient of 0.12 or more but less than 0.15

3.10.2.4 Construction for areas with an acceleration coefficient of 0.15 or greater

PART 3.10 EXPLANATORY INFORMATION

Explanatory information:

These provisions have been introduced to address design requirements for increased structural loading conditions that may occur due to geographical, topographical or climatic conditions that are beyond the scope of the preceding Parts of the *Housing Provisions*.

These provisions are to be read in conjunction with the other relevant requirements of this code.

eg For masonry construction in [Part 3.10.1](#), the walls will be required to be designed in accordance with AS 3700. However, the lintels, *flashings* and *damp proof courses* can be installed in accordance with [Part 3.3](#).

PART 3.10.1 HIGH WIND AREAS

Appropriate Performance Requirements

Where an alternative method of constructing in *high wind areas* is proposed as an *Alternative Solution* to that described in Part 3.10.1, that proposal must comply with—

- (a) *Performance Requirement P2.1*; and
- (b) the relevant *Performance Requirements* determined in accordance with **1.0.10**.

Acceptable construction manuals
--

3.10.1.0

Performance Requirement P2.1 is satisfied for a building constructed in a *high wind area* if it complies with one or more of the following manuals:

- (a) Masonry—AS 3700 Masonry structures.
- (b) The Northern Territory Deemed-to-Comply Standards Manual.
- (c) Timber—
 - (i) * * * * *
 - (ii) * * * * *
 - (iii) AS 1684.2—Residential timber-framed construction—Non-cyclonic areas.
 - (iv) AS 1684.3—Residential timber-framed construction—Cyclonic areas.
- (d) Steel—
 - (i) AS 3623—Domestic metal framing; or
 - (ii) AS 4100—Steel framing; or
 - (iii) AS 4600—Cold-formed steel structures.
- (e) Glazed assemblies:
 - (i) AS 2047 for the following glazed assemblies in an external wall:
 - (A) Windows excluding those listed in (ii).
 - (B) Sliding doors with a frame.
 - (C) Adjustable louvres.
 - (D) Window walls with one piece framing.
 - (ii) AS 1288 for all glazed assemblies not covered by (i) and the following glazed assemblies:
 - (A) All glazed assemblies not in an external wall.
 - (B) Hinged doors, including French doors and bi-fold doors.
 - (C) Revolving doors.

- (D) Fixed louvres.
- (E) Skylights, roof lights and windows in other than the vertical plane.
- (F) Sliding doors without a frame.
- (G) Windows constructed on site and architectural one-off windows, which are not design tested in accordance with AS 2047.
- (H) Second-hand windows, re-used windows, recycled windows and replacement windows.
- (I) Heritage windows.
- (J) Timber windows in wind classification N3 or C1.

Explanatory information:

The reference to heritage windows in **3.10.1.0(e)(ii)(I)** is intended to apply to windows in heritage buildings. The method of determining a heritage building is normally covered by the relevant State or Territory authority.

The reference to timber windows in wind classification N3 or C1 in **3.10.1.0(e)(ii)(J)** is limited to a six month period to allow industry time to expand the generic design provisions in AS 2047 to include designs suitable for these wind classifications. After this period, timber windows in wind classification N3 or C1 will need to fully comply with AS 2047.

STATE AND TERRITORY VARIATIONS

Add 3.10.1.0(f) and (g) in the Northern Territory.

- (f) Metal clad roofing

Test for strength—Metal roofing and its fitments should be capable of withstanding without failure, the test application of 10,000 cycles of working load from zero to that maximum at a rate of 3 Hz, followed by a static load test of 1.8 times the working load.

- (g) Masonry veneer—Masonry veneer construction must be designed so that the structural framing to which the masonry veneer is tied will ensure the stability of the masonry veneer.

STATE AND TERRITORY VARIATIONS

3.10.1.0(e)(i) is replaced by the following clause in Queensland:

- (i) AS 2047 for the following glazed assemblies in an external wall, with the exception that Tables 2.1 and 2.5 of AS 2047 are omitted and the following Tables are inserted:
 - (A) Windows excluding those listed in (ii).
 - (B) Sliding doors with a frame.
 - (C) Adjustable louvres.
 - (D) Window walls with one piece framing.

TABLE 2.1 WINDOW RATINGS FOR HOUSING

Window rating	Serviceability design wind pressure, Pa
N1	500
N2	700

Window rating	Serviceability design wind pressure, Pa
N3, C1	1000
N4, C2	1500
N5, C3	2200
N6, C4	3000

TABLE 2.5 ULTIMATE STRENGTH TEST PRESSURES

Window rating	Ultimate strength test pressure, Pa
N1	700
N2	1000
N3, C1	1500
N4, C2	2300
N5, C3	3300
N6, C4	4500

Figure 3.10.1.4
CYCLONIC AREAS

Note: High wind areas exist outside the cyclonic regions indicated on this map.

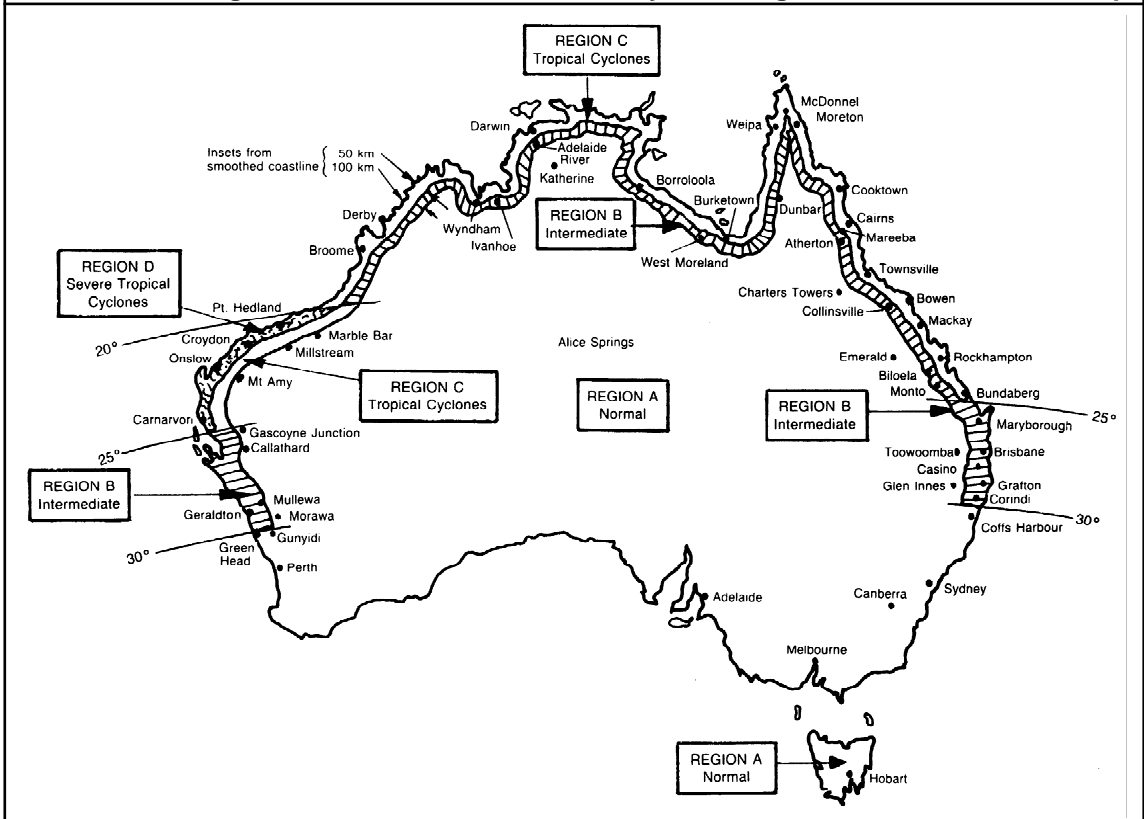

Explanatory information: Construction in high wind areas

The intent of building construction in *high wind areas* is to ensure the structure has sufficient strength to transfer wind forces to the ground with an adequate safety margin to prevent the collapse of the building and the building being lifted, or slid off its foundations.

To resist these forces it is necessary to have—

- (a) an anchorage system, where the roof is connected by the walls to the footings by a chain of connections; and
- (b) a bracing system to prevent horizontal collapse due to wind forces; and
- (c) continuity of the system where each structural element is interlocked to its adjoining structural element throughout the building.

Anchorage

Anchorage of the system is achieved by using a variety of proprietary connectors. Each connector must be capable of carrying the uplift force, because the ability of the building to resist the wind forces is directly related to its weakest link.

Acceptable construction manuals to achieve these requirements are described in this Part.

PART 3.10.2 EARTHQUAKE AREAS

Appropriate Performance Requirements

Where an alternative design is proposed as an *Alternative Solution* to that described in Part 3.10.2, that proposal must comply with—

- (a) *Performance Requirement P2.1*; and
- (b) the relevant *Performance Requirements* determined in accordance with **1.0.10**.

Definitions

3.10.2

The following definitions are used in this Part:

Acceleration coefficient means an index related to the expected severity of earthquake ground motion, as determined under AS 1170.4 and described in **Figure 3.10.2.1**.

Design category : means the *design category* given in Table 2.6 of AS 1170.4. Domestic structures are separated into three earthquake design categories H1, H2 and H3 in order of increasing potential to be damaged by earthquake loads.

Framing connector means a manufactured connector system for timber joints formed from 1.2 mm minimum thickness galvanised steel and punched to take nails.

A. Acceptable construction manuals

3.10.2.0

Performance Requirement P2.1 for Class 1 and 10 buildings constructed in areas subject to seismic activity is satisfied if the building is constructed in accordance with the applicable construction manuals listed in **Part 3.11**.

Explanatory information:

Most domestic structures are not required to be specifically designed for earthquakes, because the construction system already in place for wind resistance is usually adequate for earthquake resistance.

Accordingly, compliance with other acceptable construction details in the *Housing Provisions* are suitable for areas with an acceleration co-efficient below 0.12 provided the building is built in an area that is not considered to be complying with a structural *design category* of H3 as defined in AS 1170.4.

SUPERSEDED
ADDITIONAL CONSTRUCTION REQUIREMENTS

Class H3 are typically *sites* identified as having soft soil (having a soil profile with more than 5 m of soft clay, loose sand, silt or uncontrolled fill) which need to be designed in accordance with [Part 3.11](#).

B. Acceptable construction practice

3.10.2.1 Application

Compliance with this Part for Class 1 and 10 buildings constructed in areas with a seismic activity *acceleration coefficient* of 0.12 or more satisfies *Performance Requirement P2.1*, provided—

- (a) the soil profile of the *site* does not have more than 5 m of soft clay, loose sand, silt or uncontrolled fill; and
- (b) the buildings—
 - (i) have a rise in storeys not more than 1; and
 - (ii) do not have—
 - (A) a roof clad with concrete or terracotta tiles; or
 - (B) masonry projections or overhangs, masonry parapets or unbraced masonry chimneys.

3.10.2.2 Construction requirements

Construction in earthquake areas must comply with the following:

- (a) In locations with an *acceleration co-efficient* of 0.12 or more but less than 0.15, a Class 1 and 10 building must comply with [3.10.2.3](#).
- (b) In locations with an *acceleration co-efficient* of 0.15 or more, a Class 1 and 10 building must comply with [3.10.2.4](#).
- (c) See [Figure 3.10.2.1](#) for *acceleration co-efficient* design values.

Explanatory information:

The principal requirement for structural detailing in domestic structures is that each of the system components are sufficiently connected together such that the forces generated by an earthquake are carried to the foundation.

Trusses, beams and the like should be restrained horizontally at their support, and for this purpose, framing connectors are sufficient.

Bracing requirements, in horizontal and vertical directions, are the same as for wind loads.

Figure 3.10.2.1
ACCELERATION CO-EFFICIENT MAP OF AUSTRALIA

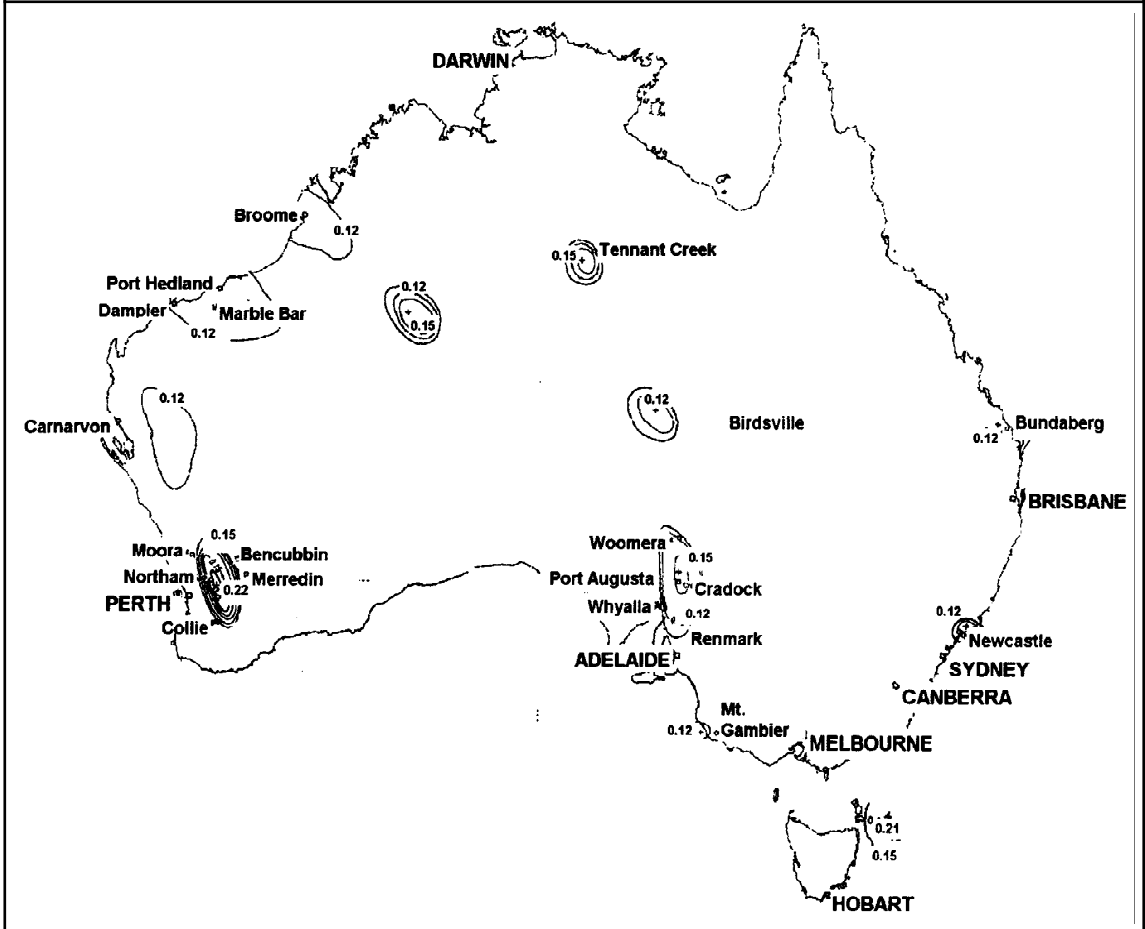

3.10.2.3 Construction for areas with an acceleration co-efficient of 0.12 or more but less than 0.15

Buildings in areas with an *acceleration co-efficient* of 0.12 or more but less than 0.15 must be constructed as follows:

- (a) Footings must comply with the appropriate provisions of [Part 3.2](#) and the additional requirements of this clause:
 - (i) Stumps must be steel, timber or reinforced concrete.
 - (ii) Bracing to stumps must be connected with galvanised M12 bolts or equivalent to comply with AS 1684 Part 2, 3 or 4—
 - (A) at not more than 10 m intervals; and
 - (B) at corner stumps—in two directions; and
 - (C) to every stump projecting more than 650 mm out of the ground.

- (iii) Floor beams must be fixed to the top of stumps with two M10 diameter bolts or equivalent fixing.
 - (iv) Bottom plates of framed structures, where fixed to a concrete slab or strip footing, must be fixed with M10 bolts or masonry anchors at not more than 1.2 m centres.
 - (v) Concrete strip footings must be continuously reinforced with two layers of reinforcement comprising two 12 mm diameter bars (Grade 400Y) per layer and tied with R6 ligatures at centres not more than 2.5 times the depth of the footing.
 - (vi) Raft slabs must incorporate monolithic edge beams.
- (b) Framed wall construction must comply with the appropriate provisions of **Part 3.4** and the additional requirements of this clause:
- (i) Metal framing must—
 - (A) comply with **Part 3.4**, AS/NZS 4600, AS/NZS 1664.1 or AS/NZS 1664.2; and
 - (B) be not less than 1.2 mm thick (other than bracing); and
 - (C) have wall plates that are continuous between cross walls or spliced to maintain strength.
 - (ii) Timber framing—
 - (A) must be fixed with timber *framing connectors* nailed with not less than three 2.8 mm diameter × 30 mm long nails to each fixing plate or the connector; and
 - (B) must be constructed of seasoned timber, fixed with at least two 2.8 mm diameter nails, machine nailed through the top or bottom wall plate into the stud; and
 - (C) wall plates must be continuous between cross walls or spliced to maintain strength.
- (c) *Unreinforced masonry* must comply with the appropriate provisions of **Part 3.3** and the additional requirements of this clause:
- (i) Internal or *external walls* 4 m or more in length must be stiffened by cross walls, columns or bracing complying with AS 1170.4 and AS 3700; and—
 - (A) cross walls must be tied to the internal leaf of *cavity walls* by fully bonding or by metal ties at every second course; and
 - (B) the mortar mix must be at least as strong as a 1:1:6; and
 - (C) masonry units must have good mortar adherence properties.
 - (ii) Bricks must—
 - (A) be laid on a full bed joint with full perpend; and
 - (B) when laid in the top two courses of internal walls and the internal leaf of *external walls*, contain no perforations.
 - (iii) Reinforcement consisting of two R6 bars (Grade 250R), or two 3.15 mm diameter bars (Grade 450W), must—
 - (A) be placed in both leaves of *external walls* in the course immediately under *window sills* and over door and *window heads*; and
 - (B) be galvanised when placed in the external leaf of an *external wall*; and
 - (C) extend not less than 300 mm beyond any supporting cross walls or columns; and
 - (D) be spliced not less than 300 mm.

- (iv) Continuous reinforced brick bond beams must be installed, comprising two R6 bars (Grade 250R), or two 3.15 mm diameter bars (Grade 450W), in each of the top three bed joints, constructed—
 - (A) on the internal leaf of all *external walls* and on all cross walls; and
 - (B) where the roof is pitched on the external leaf of an *external wall*, in that external leaf; and
 - (C) in cross walls, turned and lapped 300 mm into the *external walls*.
- (v) Top wall plates must be fixed by masonry anchors or equivalent fixing connected to the second top course of walls, at not more than 1.8 m centres.
- (d) Veneers that comprise an external leaf of masonry connected to internal walls of timber or metal framing must be fixed in accordance with AS 3700.
- (e) Roof framing must comply with the appropriate provisions of [Part 3.4](#); and
 - (i) be fixed to the top wall plate using timber *framing connectors* nailed with not less than three 2.8 mm diameter × 30 mm long nails to each fixing plate of the connector; and
 - (ii) incorporate roof bracing to transfer all horizontal loads directly to cross walls.

3.10.2.4 Construction for areas with an acceleration co-efficient of 0.15 or greater

Buildings in areas with an *acceleration co-efficient* of 0.15 or greater must be constructed as follows:

- (a) Footings must comply with the appropriate provisions of [Part 3.2](#) and the additional requirements of this clause:
 - (i) Stumps must be steel, timber or reinforced concrete.
 - (ii) Bracing to stumps must be connected with galvanised M12 bolts or equivalent to comply with AS 1684 Part 2, 3 or 4—
 - (A) at not more than 8 m intervals; and
 - (B) at corner stumps—in two directions; and
 - (C) to every stump projecting more than 500 mm out of the ground.
 - (iii) Floor beams must be fixed to the top of stumps with two M10 diameter bolts or equivalent fixing.
 - (iv) Bottom plates of framed structures, where fixed to a concrete raft or strip footing, must be fixed with M10 bolts or masonry anchors at not more than 1.2 m centres.
 - (v) Concrete strip footings must be continuously reinforced with two layers of reinforcement comprising two 12 mm diameter bars (Grade 400Y) per layer and tied with R6 ligatures at centres not more than 2.5 times the depth of the footing.
 - (vi) Raft slabs must incorporate monolithic edge beams.
- (b) Framed wall construction must comply with the appropriate provisions of [Part 3.4](#) and the additional requirements of this clause:
 - (i) Metal framing—
 - (A) must comply with [Part 3.4](#), AS/NZS 4600 or AS/NZS 1664.1 or AS/NZS 1664.2; and
 - (B) must be not less than 1.2 m thick (other than bracing); and

- (C) wall plates must be continuous between cross walls or spliced to maintain strength.
- (ii) Timber framing must comply with the following—
 - (A) *Timber framing connectors* must be nailed with not less than three 2.8 mm diameter × 30 mm long nails to each fixing plate or the connector.
 - (B) Seasoned timber, must be fixed with not less than two 2.8 mm diameter nails, machine nailed through the top or bottom wall plate into the stud.
 - (C) Wall plates must be continuous between cross walls or spliced to maintain strength.
- (c) Veneer on frame construction must comply with the following:
 - (i) Veneers that comprise an external leaf of masonry connected to internal walls of timber or metal framing must be fixed in accordance with AS 3700.
 - (ii) Timber framing:
 - (A) Wall plates must be—
 - (aa) fixed to transfer lateral loads between frames of *external walls* and frames of internal walls; and
 - (bb) at least F8 grade timber minimum dimensions not less than 100 × 50 mm where cross walls are spaced at not more than 4.8 m centres.
 - (B) *External walls* must be fixed to supporting cross walls at or near top wall plate level by not less than two *framing connectors* with not less than three 2.8 mm diameter nails to each plate of the connector or by bolting the frames together with M10 minimum diameter bolts.
 - (iii) Metal framing:
 - (A) Wall plates must—
 - (aa) be fixed to transfer lateral loads between frames of *external walls* and frames of internal walls; and
 - (bb) have minimum dimensions of 78×31×1.2 mm where cross walls are spaced at not more than 5.5 m centres, and stiffened by an additional 75×78×1.6 mm plate where the span is more than 3.5 m.
 - (B) *External walls* must be fixed to supporting cross walls at or near top wall plate level by at least two *timber framing connectors* or by bolting the frames together with M10 minimum diameter bolts.
 - (iv) The veneer of *external walls* must be fixed to the frame with 100 × 100 mm galvanised steel mesh.
 - (v) Masonry veneer must not be placed over openings or in gables.
- (d) Roof framing must comply with the appropriate provisions of Part 3.4; and
 - (i) incorporate roof bracing to transfer all horizontal loads directly to cross walls; and
 - (ii) be fixed to the top wall plate using timber *framing connectors* nailed with at least three 2.8 mm diameter × 30 mm long nails to each fixing plate of the connector.

PART **3.11**

STRUCTURAL DESIGN MANUALS

- 3.11.1 Application
- 3.11.2 Acceptable Structural Design Manuals
- 3.11.3 Loading Requirements
- 3.11.4 Structural Design manuals

PART 3.11 CONTENTS

PART 3.11 STRUCTURAL DESIGN MANUALS

Explanatory Information

3.11 Structural design manuals

- 3.11.1 Application
- 3.11.2 Resistance to actions
- 3.11.3 Determination of individual actions
- 3.11.4 Acceptable structural design manuals
- 3.11.5 Loading requirements
- 3.11.6 Determination of structural resistance of materials and forms of construction

PART 3.11 EXPLANATORY INFORMATION

Explanatory information:

This Part of the *Housing Provisions* contains a list of deemed-to-satisfy codes (structural design manuals) that can be used to design building elements using engineering principles.

These provisions can be used in conjunction with both the *Performance Requirements* (listed in Section 2) and the *Deemed-to-Satisfy Provisions* (listed in Section 3—Parts 1 to 12). This combined approach is acceptable and meets the requirements of the *Housing Provisions*.

PART 3.11 STRUCTURAL DESIGN MANUALS

Appropriate Performance Requirements

Where it is proposed to use an alternative structural design manual as an *Alternative Solution* to that described in Part 3.11, that proposal must comply with—

- (a) *Performance Requirement P2.1*; and
- (b) the relevant *Performance Requirements* determined in accordance with **1.0.10**.

Acceptable construction manuals

3.11.1 Application

Performance Requirement P2.1 is satisfied by complying with—

- (a) **3.11.2**, **3.11.3** and **3.11.6**; or
- (b) **3.11.4**, **3.11.5** and **3.11.6**; or
- (c) the relevant provisions of other Parts of Section 3 of the *Housing Provisions* relating to structural elements; or
- (d) a combination of (a) and (c); or
- (e) a combination of (b) and (c).

Explanatory information:

The basic difference between **3.11.1(a)** and **3.11.1(b)** is that **3.11.1(a)** allows the use of the 2002 editions of AS/NZS 1170 Parts 0, 1 and 2, whereas **3.11.1(b)** allows the use of the 1989 editions of AS 1170 Parts 1 and 2.

Although **3.11.1** allows a combination of methods for determining the structural requirements for a building, it is not acceptable to use a combination of **3.11.1(a)** and **3.11.1(b)**.

3.11.2 Resistance to actions

The resistance of a building or structure must be greater than the most critical action effect resulting from different combinations of actions, where—

- (a) the most critical action effect on a building or structure must be determined in accordance with **3.11.3** and the general design procedures contained in AS/NZS 1170.0; and
- (b) the resistance of a building or structure must be determined in accordance with **3.11.6**.

3.11.3 Determination of individual actions

The magnitude of individual actions must be determined in accordance with the following:

- (a) Permanent actions:

- (i) the design or known dimensions of the building or structure; and
 - (ii) the unit weight of the construction; and
 - (iii) AS/NZS 1170.1.
- (b) Imposed actions:
- (i) the known loads that will be imposed during the occupation or use of the building or structure; and
 - (ii) *construction activity actions*; and
 - (iii) AS/NZS 1170.1.
- (c) Wind, snow and earthquake actions:
- (i) the applicable annual probability of design event for safety, determined by—
 - (A) assigning the building or structure an Importance Level in accordance with [Table 3.11.3a](#); and
 - (B) determining the corresponding annual probability of exceedance for safety in accordance with [Table 3.11.3b](#); and
 - (ii) AS/NZS 1170.2, AS 1170.3 (as modified by AS/NZS 1170.1) and AS 1170.4 (as modified by AS/NZS 1170.0) as appropriate.
- (d) Action not covered in (a), (b) and (c) above:
- (i) the nature of the action; and
 - (ii) the nature of the building or structure; and
 - (iii) the Importance Level of the building or structure determined in accordance with [Table 3.11.3a](#); and
 - (iv) AS/NZS 1170.1.
- (e) For the purposes of (d) the actions include but are not limited to—
- (i) liquid pressure action; and
 - (ii) ground water action; and
 - (iii) rainwater action (including ponding action); and
 - (iv) earth pressure action; and
 - (v) differential movement; and
 - (vi) time dependent effects (including creep and shrinkage); and
 - (vii) thermal effects; and
 - (viii) ground movement caused by—
 - (A) swelling, shrinkage or freezing of the subsoil; and
 - (B) landslip or subsidence; and
 - (C) siteworks associated with the building or structure; and
 - (ix) *construction activity actions*.

Table 3.11.3a IMPORTANCE LEVELS OF BUILDINGS AND STRUCTURES

Importance Level	Building types
1	Buildings or structures presenting a low degree of hazard to life and <i>other property</i> in the case of failure.
2	Buildings or structures not included in Importance Level 1.

Table 3.11.3b DESIGN EVENTS FOR SAFETY

Importance Level	Annual probability of exceedance			
	Wind		Snow	Earthquake
	Non-cyclonic	Cyclonic		
1	1:100	1:200	1:100	1:500
2	1:500	1:500	1:150	1:500

3.11.4 Acceptable structural design manuals

A Class 1 and 10 building must be designed—

- (a) to resist the loads determined in accordance with the appropriate aspects of the design codes described in [3.11.5](#); and
- (b) in accordance with the appropriate structural design code listed in [3.11.6](#).

3.11.5 Loading requirements

A Class 1 and 10 building must be designed to resist loads as determined in accordance with the following design codes as appropriate:

- (a) Dead and live loads and load combinations—AS 1170.1.
- (b) Wind loads—AS 1170.2 or AS 4055.
- (c) Snow loads—AS 1170.3.
- (d) Earthquake loads—AS 1170.4.

3.11.6 Determination of structural resistance of materials and forms of construction

The structural resistance of materials and forms of construction must be determined in accordance with the following:

- (a) Steel construction:
 - (i) AS/NZS 4600—Cold formed steel structures.
 - (ii) AS 3623—Domestic metal framing.
 - (iii) AS 4100—Steel structures.
- (b) Aluminium construction:
 - (i) AS/NZS 1664—Aluminium structures, Part 1—Limit state design.

- (ii) AS/NZS 1664—Aluminium structures, Part 2—Allowable stress design.
- (c) Timber construction:
AS 1720.1—Timber structures code.
- (d) Footings:
(i) AS 2870—Residential slabs and footings.
(ii) AS 3600—Concrete structures.
- (e) Piling:
AS 2159—Piling—Design and information.
- (f) Concrete construction (including reinforced and prestressed concrete):
AS 3600—Concrete structures.
- (g) Masonry (including masonry-veneer, *unreinforced masonry* and *reinforced masonry*):
AS 3700—SAA Masonry structures.
- (h) Composite steel and concrete:
AS 2327.1—Composite construction in steel and concrete.
- (i) Glazed assemblies:
(i) AS 2047 for the following glazed assemblies in an external wall:
 - (A) Windows excluding those listed in (ii).
 - (B) Sliding doors with a frame.
 - (C) Adjustable louvres.
 - (D) Window walls with one piece framing.
- (ii) AS 1288 for all glazed assemblies not covered by (i) and the following glazed assemblies:
 - (A) All glazed assemblies not in an external wall.
 - (B) Hinged doors, including French doors and bi-fold doors.
 - (C) Revolving doors.
 - (D) Fixed louvres.
 - (E) Skylights, roof lights and windows in other than the vertical plane.
 - (F) Sliding doors without a frame.
 - (G) Windows constructed on site and architectural one-off windows, which are not design tested in accordance with AS 2047.
 - (H) Second-hand windows, re-used windows, recycled windows and replacement windows.
 - (I) Heritage windows.

Explanatory information:

The reference to heritage windows in **3.11.6(i)(ii)(I)** is intended to apply to windows in heritage buildings. The method of determining a heritage building is normally covered by the relevant State or Territory authority.

STATE AND TERRITORY VARIATIONS

3.11.6(i)(i) is replaced by the following clause in Queensland:

- (i) AS 2047 for the following glazed assemblies in an external wall, with the exception that Tables 2.1 and 2.5 of AS 2047 are omitted and the following Tables are inserted:
 - (A) Windows excluding those listed in (ii).
 - (B) Sliding doors with a frame.
 - (C) Adjustable louvres.
 - (D) Window walls with one piece framing.

TABLE 2.1 WINDOW RATINGS FOR HOUSING

Window rating	Serviceability design wind pressure, Pa
N1	500
N2	700
N3, C1	1000
N4, C2	1500
N5, C3	2200
N6, C4	3000

TABLE 2.5 ULTIMATE STRENGTH TEST PRESSURES

Window rating	Ultimate strength test pressure, Pa
N1	700
N2	1000
N3, C1	1500
N4, C2	2300
N5, C3	3300
N6, C4	4500

- (j) Earthwall construction.
NBTC Bulletin 5, Edition 4.
- (k) Structures for primary production purposes in rural areas:
AS 2867—Farm structures—General requirements for structural design.

PART **3.12**

ENERGY EFFICIENCY

- 3.12.1 Building Fabric
- 3.12.2 External Glazing
- 3.12.3 Building Sealing
- 3.12.1 Air Movement
- 3.12.1 Services

PART 3.12 CONTENTS

PART 3.12 ENERGY EFFICIENCY

3.12 Energy efficiency

3.12 Definitions

3.12.0 Application of Part 3.12

3.12.1 Building fabric

3.12.1 Application

3.12.1.1 Building fabric insulation

3.12.1.2 Roofs

3.12.1.3 Roof lights

3.12.1.4 External walls

3.12.1.5 Floors

3.12.1.6 Attached Class 10a buildings

3.12.2 External Glazing

3.12.2 Application

3.12.2.1 External glazing

3.12.2.2 Shading

3.12.3 Building Sealing

3.12.3 Application

3.12.3.0 A. Acceptable construction manual

3.12.3.1 Chimneys and flues

3.12.3.2 Roof lights

3.12.3.3 External windows and doors

3.12.3.4 Exhaust fans

3.12.3.5 Construction of roofs, walls and floors

3.12.4 Air Movement

3.12.4 Application

3.12.4.1 Air movement

3.12.4.2 Ventilation openings

3.12.4.3 Ceiling fans and evaporative coolers

3.12.5 Services

3.12.5 Application

3.12.5.0 Acceptable construction manual

3.12.5.1 Insulation of services

3.12.5.2 Central heating water piping

3.12.5.3 Heating and cooling ductwork

PART 3.12 ENERGY EFFICIENCY

Appropriate Performance Requirements

Where an alternative energy efficiency design is proposed as an *Alternative Solution* to that described in Part 3.12, that proposal must comply with—

- (a) Performance Requirement **P2.6.1**; and
- (b) Performance Requirement **P2.6.2**; and
- (c) the relevant *Performance Requirements* determined in accordance with **1.0.10**.

STATE AND TERRITORY VARIATIONS

1. **Part 3.12 does not apply in the Australian Capital Territory**

Note: The Australian Capital Territory Additions contain energy efficiency measures that apply in the Australian Capital Territory.

2. **Part 3.12 does not apply in New South Wales**

Note: The New South Wales Additions contain energy efficiency measures that apply in New South Wales.

3. **3.12.1.1(d) applies in Victoria. The remainder of Part 3.12 does not apply in Victoria except in circumstances outlined in the Victoria Additions.**

Note: The Victoria Additions contain energy efficiency measures that apply in Victoria.

Definitions

3.12

The following definitions are used in this Part:

Conditioned space means a space within a building—

- (a) that is heated or cooled by the building's *domestic services*; but
- (b) excludes a heater with a capacity of not more than 1.2 kW installed in a non-habitable room.

Piping means an assembly of pipes, with or without valves or other fittings, connected together for the conveyance of liquids.

Reflective insulation means a building membrane with a reflective surface such as a reflective foil laminate, reflective barrier, foil batt or the like capable of reducing radiant heat flow.

Explanatory information:

1. Typical *R-values* achieved by adding *reflective insulation* are given in the explanatory information accompanying Figures 3.12.1.1, 3.12.1.3 and 3.12.1.4. Information on specific products may be obtained from *reflective insulation* manufacturers.
2. The surface of *reflective insulation* may be described in terms of its emittance (or infra-red emittance) or in terms of its reflectance (or solar reflectance). Generally, for the surface of a particular *reflective insulation*—
emittance + reflectance = 1

R-Value means the thermal resistance ($m^2.K/W$) of a component calculated by dividing its thickness by its thermal conductivity.

Total R-Value means the sum of the *R-Values* of the individual component layers in a composite element including the air space and associated surface resistances.

Total U-Value means the thermal transmittance ($W/m^2.K$) of the composite element including the air space and associated surface transmittance.

Ventilation opening means an opening in the *external wall*, floor or roof of a building designed to allow air movement into or out of the building by natural means including a permanent opening, an openable part of a *window*, a door or other device which can be held open.

3.12.0 Application of Part 3.12

- (a) *Performance Requirement* P2.6.1 for the thermal performance of the building is satisfied by complying with—
 - (i) for the building *fabric*, Part 3.12.1; and
 - (ii) for external *glazing* and shading, Part 3.12.2; and
 - (iii) for building sealing, **Part 3.12.3**; and
 - (iv) for air movement, **Part 3.12.4**.
- (b) Compliance with **Part 3.12.5** satisfies *Performance Requirement* **P2.6.2** for the energy efficiency of a central heating water system and heating and cooling ductwork.

Explanatory information:

It is expected that most houses constructed to meet the *Deemed-to-Satisfy Provisions* in this Part for *climate zones* 4, 5, 6, 7 and 8 will achieve a level of thermal performance equivalent to a 4 star house energy rating as described in **V2.6.2.1(b)**.

PART 3.12.1 BUILDING FABRIC

3.12.1 Application

This Part applies to—

- (a) a Class 1 building; and
- (b) a Class 10a building with a *conditioned space*.

Acceptable construction practice

3.12.1.1 Building fabric thermal insulation

- (a) Where *required*, insulation must comply with 3.12.1.1(d) and be installed so that it—
 - (i) abuts or overlaps adjoining insulation; and
 - (ii) forms a continuous barrier with ceilings, walls, bulkheads, floors or the like that inherently contribute to the thermal barrier; and
 - (iii) does not affect the safe or effective operation of a *domestic service* or fitting.

Explanatory information:

Typical arrangements for continuous thermal barriers.

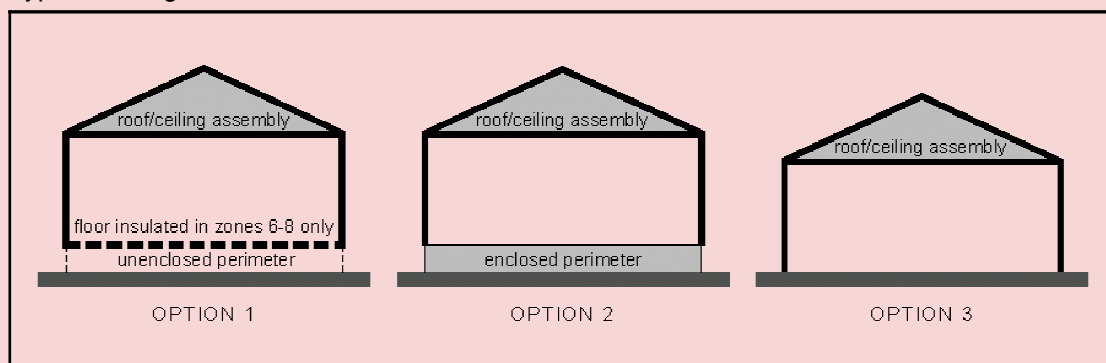

- (b) *Reflective insulation* must be installed with—
 - (i) an airspace, specified in accordance with 3.12.1.1(d), between a reflective side of the *reflective insulation* and a building lining or cladding; and
 - (ii) the *reflective insulation* closely fitted against any penetration, door or *window* opening; and
 - (iii) the *reflective insulation* adequately supported by framing members; and
 - (iv) each adjoining sheet of roll membrane being—

- (A) overlapped not less than 50 mm; or
 - (B) taped together.
- (c) Bulk insulation must be installed—
- (i) so that it maintains its position and thickness; and
 - (ii) in ceilings where there is no bulk insulation or *reflective insulation* in the wall, so that it overlaps the wall member by not less than 50 mm; and
- (d) Insulation must be in accordance with—
- (i) AS/NZS 4859.1; or
 - (ii) AS 2464.3 for loose fill insulation; or
 - (iii) AS 2464.5 for determining thermal transmission properties by means of a heat flow meter; or
 - (iv) AS 2464.6 for determining thermal transmission properties by means of a guarded hot plate.

Explanatory information:

1. The *R-Value* of *reflective insulation* is affected by the airspace between a reflective side of the *reflective insulation* and the building lining or cladding. For further information on *reflective insulation*, refer to the explanatory information accompanying Figure 3.12.1.1.
2. Care should be taken when installing insulation to ensure that it does not interfere with the safety or performance of *domestic services* and fittings such as heating flues, recessed light fittings, gas appliances and general plumbing and electrical components. This includes providing appropriate clearance as detailed in relevant legislation and referenced standards such as for electrical, gas and fuel oil installations.
3. Artificial cooling of buildings in some climates can cause condensation to form inside the layers of the building *envelope*. Such condensation can cause significant structural or cosmetic damage to the *envelope* before it is detected. Associated mould growth may also create health risks to the occupants. Effective control of condensation is a complex issue. In some locations a fully sealed vapour barrier may need to be installed on the more humid, or generally warmer, side of the insulation.
4. AS/NZS 4859 Part 1 supersedes AS 2464 Parts 3, 5 and 6. To provide industry time to adjust to AS/NZS 4859 Part 1, sub-clause 3.12.1.1(d) allows the use of either standard. It is anticipated in May 2005, AS 2464 Parts 3, 5 and 6 will be withdrawn from BCA 2005.

3.12.1.2 Roofs

A roof must—

- (a) achieve the minimum *Total R-Value* specified in [Table 3.12.1.1](#); or
- (b) in *climate zones* 1, 2 and 3 for a pitched roof with a flat ceiling have—
 - (i) a solar absorptance value of not more than 0.55; and
 - (ii) *reflective insulation* with an emittance of not more than 0.05 downwards and 0.2 upwards, installed below the roof; and
 - (iii) a roof space ventilated by—

- (A) gable vents, ridge vents, eaves vents, roof vents or the like that—
 - (aa) are evenly distributed to allow an unobstructed flow of air; and
 - (bb) are located to ensure, where practicable, there are no dead air spaces; and
 - (cc) have an aggregate fixed open area of not less than 1.0% of the ceiling area; or
- (B) not less than 2 wind-driven roof ventilators having an aggregate opening area of not less than 0.14 m² in conjunction with gable vents, ridge vents, eaves vents, roof vents or the like having an aggregate fixed open area of not less than 0.2% of the ceiling area.

Table 3.12.1.1 ROOFS—MINIMUM TOTAL R-VALUE FOR EACH CLIMATE ZONE

Climate Zones	1	2		3	4	5	6	7	8
		Altitude less than 300 m	Altitude 300 m or more						
Minimum Total R-Value	2.2	2.2	2.5	2.2	3.0	2.7	3.2	3.8	4.3
Direction of heat flow	Downwards		Downwards and upwards	Upwards					
<p>Note: Altitude means the height above the Australian Height Datum at the location where the building is to be constructed.</p>									

Explanatory information:

1. The roof space ventilation option applies to a pitched roof with a flat ceiling to ensure that efficient cross ventilation is achieved in the roof space to remove hot air. Roof space ventilation is generally not suitable for most flat, skillion, cathedral ceiling and similar roof types because of the lack of space between the ceiling and roof.
2. Care should be taken to ensure that the roof *ventilation openings* do not allow rain penetration and that they comply with appropriate bushfire provisions.
3. Gaps between roof tiles with sarking (or *reflective insulation* at rafter level) and metal sheet roofing are not acceptable methods of providing roof space ventilation.
4. Compliance with the ventilation provisions in 3.12.1.2(b)(iii) may result in the ingress of wind driven rain or fine dust, or stimulate the growth of mould or fungus in the roof enclosure. Consideration should therefore be given to the surrounding environmental features prior to adopting this as an alternative to the roof insulation provisions in 3.12.1.2(a).
5. A light coloured roof reduces the flow of heat from solar radiation better than a dark colour roof. A roof with a solar absorptance value of less than 0.55 means the roof is of

a light colour such as white, off-white, cream or dull zinc aluminium. Typical absorptance values are as follows.

Typical Absorptance Values

Colour	Value
Slate (dark grey)	0.9
Red, green	0.75
Yellow, buff	0.6
Zinc aluminium—dull	0.55
Galvanised steel—dull	0.55
Light grey	0.45
Off white	0.35
Light cream	0.3

- (c) A roof, or roof and associated ceiling, is deemed to have the *Total R-Value* required by [Table 3.12.1.1](#) for the relevant *climate zone* if it complies with the appropriate construction in [Figure 3.12.1.1](#).

Figure 3.12.1.1 TYPICAL INSULATION OPTIONS FOR TYPICAL ROOF AND CEILING CONSTRUCTION									
<i>Climate zones</i>	1, 2 (below 300 m altitude)	2 (at or above 300 m altitude)	3	4	5	6	7	8	
Minimum required <i>Total R-Value</i>	2.2	2.5	2.2	3.0	2.7	3.2	3.8	4.3	
Direction of heat flow	Downwards	Downwards and upwards		Upwards					
(a)	Flat roof, skillion roof and cathedral ceiling—Ceiling lining under rafters								
Tiled roof	<i>Total R-Value</i> of roof and ceiling materials	0.4	0.4		0.41				
	Minimum added <i>R-Value</i> of insulation	1.8	2.1	1.8	2.59	2.29	2.79	3.39	3.89

Figure 3.12.1.1 TYPICAL INSULATION OPTIONS FOR TYPICAL ROOF AND CEILING CONSTRUCTION									
Climate zones		1, 2 (below 300 m altitude)	2 (at or above 300 m altitude)	3	4	5	6	7	8
Metal roof	<i>Total R-Value of roof and ceiling materials</i>	0.38	0.38	0.39					
	<i>Minimum added R-Value of insulation</i>	1.82	2.12	1.82	2.61	2.31	2.81	3.41	3.91
(b)	Flat roof, skillion roof and cathedral ceiling—Ceiling lining on top of rafters (exposed rafters)								
Tiled roof	<i>Total R-Value of roof and ceiling materials</i>	0.41	0.41	0.41					
	<i>Minimum added R-Value of insulation</i>	1.79	2.09	1.79	2.59	2.29	2.79	3.39	3.89
Metal roof	<i>Total R-Value of roof and ceiling materials</i>	0.37	0.37	0.39					
	<i>Minimum added R-Value of insulation</i>	1.83	2.13	1.83	2.61	2.31	2.81	3.41	3.91

Figure 3.12.1.1 TYPICAL INSULATION OPTIONS FOR TYPICAL ROOF AND CEILING CONSTRUCTION									
Climate zones		1, 2 (below 300 m altitude)	2 (at or above 300 m altitude)	3	4	5	6	7	8
(a)	Flat roof, skillion roof and cathedral ceiling—Ceiling lining under rafters		(b)	Flat roof, skillion roof and cathedral ceiling—Exposed rafters					
	Minimum required Total R-Value	2.2	2.5	2.2	3.0	2.7	3.2	3.8	4.3
Direction of heat flow		Downwards	Downwards and upwards	Upwards					
(c)	Flat ceiling with pitched roof—Tiled roof								
Total R-Value of roof and ceiling materials		0.7	0.35	0.35					
Minimum added R-Value of insulation		1.5	2.15	1.85	2.65	2.35	2.85	3.45	3.95
(d)	Flat ceiling with pitched roof—Metal roof								
Total R-Value of roof and ceiling materials		0.5	0.4	0.4					
Minimum added R-Value of insulation		1.7	2.1	1.8	2.6	2.3	2.8	3.4	3.9
(c)	Flat ceiling with pitched roof—Tiled roof		(d)	Flat ceiling with pitched roof—Metal roof					

Figure 3.12.1.1 TYPICAL INSULATION OPTIONS FOR TYPICAL ROOF AND CEILING CONSTRUCTION

<i>Climate zones</i>	1, 2 (below 300 m altitude)	2 (at or above 300 m altitude)	3	4	5	6	7	8
Note:								
1.	The <i>Total R-Value</i> of the roof and ceiling materials may need to be adjusted if other building elements such as sarking are also installed.							
2.	<i>Required</i> insulation can be installed in the roof, the ceiling or a combination of both.							
3.	Altitude means the height in metres above the Australian Height Datum where the building is to be constructed.							
4.	The <i>Total R-Value</i> in Figure 3.12.1.1(c) is based on there being some ventilation of the roof space through the gaps in the roof tiles. However, Figures 3.12.1.1(a), (b) and (d) assume that there is no ventilation of the roof space through the metal roofing.							

Explanatory information:

1. Typical construction:

Figures 3.12.1.1, 3.12.1.3 and 3.12.1.4 provide examples of typical locations for insulation in various roofs and ceiling, walls and floors. The *Total R-Value required* is achieved by adding the *Total R-Value* of the basic element, ie roof and ceiling, walls or floors, and the *R-Value* of any additional insulation incorporated in that element (described in **Figures 3.12.1.1, 3.12.1.3 and 3.12.1.4** as the “minimum added *R-Value* of insulation”). The *Total R-Value* of the basic roof and ceiling has been determined by adding together the *R-Values* of the outdoor air film, roof cladding, roof air space, ceiling sheet lining and internal film.
2. Bridging:

Irrespective of the framing material used, the minimum added *R-Value* specified in **Figures 3.12.1.1, 3.12.1.3 and 3.12.1.4** is deemed to include the effect of thermal bridging created by framing members.
3. Location of insulation:

The insulation location options can be used either separately or in combination provided the *required* thermal performance is achieved and other aspects of the building's integrity are not compromised. Alternatively, the designer may choose another method to insulate provided the *Total R-Value* is achieved. It should be noted that insulation installed under the roof, rather than on the ceiling, in a building with a large roof space is less effective because of the additional volume of roof air space that would need to be heated or cooled.

4. Choice of insulation

There are a number of different insulation products that may be used to achieve the minimum added *R-Value*. However, care should be taken to ensure that the choice made is appropriate for the construction and climatic conditions as the location and relationship between options in [Figures 3.12.1.1, 3.12.1.3 and 3.12.1.4](#) may not be suitable in all circumstances for both practical and technical reasons. For instance, in some *climate zones*, *reflective insulation* sheet should be installed with due consideration of condensation and associated interaction with adjoining building materials.

Reflective insulation with two reflective sides is considered to achieve the following *R-Values* when used in conjunction with the *Total R-Value* of a pitched roof and ceiling construction described in [Figure 3.12.1.1](#). To achieve these values, *reflective insulation* is *required* to have a minimum air space of 15 mm between a reflective side of the *reflective insulation* and the adjoining building lining or cladding (see [3.12.1.1\(b\)](#)).

The actual *R-Value* added by *reflective insulation* should be determined for each product in accordance with the standards prescribed in 3.12.1.1(d), which take into consideration factors such as the number of adjacent airspaces, dimensions of the adjacent airspace, whether the space is ventilated and the presence of an anti-glare coating. When *reflective insulation* has an anti-glare coating on one side, the emittance value of that side will be greater than the value of the uncoated side.

Also, where another emittance value for *reflective insulation* is used (other than the value used in the table below), care should be taken to ensure that the number of airspaces allowed for is consistent with the form of construction and whether the airspace is reflective, partially reflective or non-reflective. Where bulk insulation fills the airspace, the *Total R-Value* should be reduced to take account of the loss of airspace.

Emittance of added <i>reflective insulation</i>	Direction of heat flow	<i>R-Value added by reflective insulation</i>					
		Pitched roof ($\geq 10^\circ$) with horizontal ceiling		Flat skillion or pitched roof ($\leq 10^\circ$) with horizontal ceiling	Pitched roof with cathedral ceilings		
		Ventilated roof space	Non-ventilated roof space		22° pitch	30° pitch	45° pitch
0.2 outer 0.05 inner	Downwards	1.21	1.21	1.28	0.96	0.86	0.66
0.2 outer 0.05 inner	Upwards	0.59	0.75	0.68	0.72	0.74	0.77
0.9 outer 0.05 inner	Downwards	1.01	0.92	1.06	0.74	0.64	0.44

Emittance of added reflective insulation	Direction of heat flow	R-Value added by reflective insulation					
		Pitched roof ($\geq 10^\circ$) with horizontal ceiling		Flat skillion or pitched roof ($\leq 10^\circ$) with horizontal ceiling	Pitched roof with cathedral ceilings		
		Ventilated roof space	Non-ventilated roof space		22° pitch	30° pitch	45° pitch
0.9 outer 0.05 inner	Upwards	0.40	0.55	0.49	0.51	0.52	0.53

Note: Ventilated roof space means ventilated at least in accordance with 3.12.1.2(b)(iii).

3.12.1.3 Roof lights

- (a) *Roof lights* serving a *habitable room* or an interconnecting space such as a corridor, hallway, stairway or the like—
- (i) if the total area of the *roof lights* is 5% or less of the *floor area* of the room or space, must comply with [Table 3.12.1.2](#); or
 - (ii) if the total area of the *roof lights* is more than 5% of the *floor area* of the room or space, may only be used, where—
 - (A) compliance with [3.8.4.2](#) can be provided only by a *roof light*; and
 - (B) the transparent and translucent area of the *roof lights*, including any imperforate ceiling diffuser, achieves—
 - (aa) a Solar Heat Gain Co-efficient of not more than 0.5; and
 - (bb) a *Total U-Value* of not more than 2.5.
- (b) The aggregate area of *roof lights* serving a building must not exceed 3% of the total floor area of the building.

Table 3.12.1.2 ROOF LIGHTS—THERMAL PERFORMANCE OF TRANSPARENT AND TRANSLUCENT ELEMENTS

Roof light shaft length (m)(see Note 1)	Total area of <i>roof lights</i> serving the room or space as a percentage of the room or space <i>floor area</i>		
	Less than 1.5%	1.5% to 3%	More than 3% and up to 5%
< 0.6	No Requirement	<i>Roof light</i> to achieve a SHGC of not more than 0.75 and a <i>Total U-Value</i> of not more than 5.0	<i>Roof light</i> to achieve a SHGC of not more than 0.75 and a <i>Total U-Value</i> of not more than 5.0

Roof light shaft length (m)(see Note 1)	Total area of <i>roof lights</i> serving the room or space as a percentage of the room or space <i>floor area</i>		
	Less than 1.5%	1.5% to 3%	More than 3% and up to 5%
0.6 to < 1.5	No Requirement	No Requirement	<i>Roof light</i> to achieve a SHGC of not more than 0.75 and a <i>Total U-Value</i> of not more than 5.0
1.5 and above	No Requirement	No Requirement	No Requirement
Notes:			
1.	<i>Roof light</i> shaft length is determined by measuring the distance from the centre of the shaft at the roof to the centre of the shaft at the ceiling level.		
2.	The total area of <i>roof lights</i> is the combined area for all <i>roof lights</i> serving the room or space.		
3.	The area of a <i>roof light</i> is the area of the roof opening that allows light to enter the building.		
4.	SHGC means Solar Heat Gain Co-efficient.		
5.	The thermal performance of a roof light may include that of an imperforate ceiling diffuser.		

3.12.1.4 External walls

- (a) The *external wall* must—
- (i) achieve the minimum *Total R-Value* specified in [Table 3.12.1.3](#) for the relevant *climate zone*; or
 - (ii) in *climate zones* 1, 2 and 3 for each storey of the building, be shaded by a verandah, balcony, eaves, carport or the like, including any attached guttering—
 - (A) having a horizontal projection from the external face of the building to the outer edge of the projection of not less than one quarter of the overall height of the wall; and
 - (B) with the overall height of the wall measured vertically from the internal floor level in accordance with [Figure 3.12.1.2](#); or
 - (iii) in *climate zones* 4 and 5, achieve a surface density of not less than 220 kg/m²; or
 - (iv) in *climate zone* 6—
 - (A) achieve a surface density of not less than 220 kg/m²; and
 - (B) be constructed on a flooring system that is in direct contact with the ground, such as a concrete slab-on-ground or the like; or
 - (v) in *climate zones* 6, 7 and 8—
 - (A) achieve a surface density of not less than 220 kg/m²; and
 - (B) incorporate insulation with an *R-Value* of not less than 1.

STATE AND TERRITORY VARIATIONS

In Queensland after 3.12.1.4 (a)(v) insert Qld 3.12.1.4 (a)(vi) as follows:

- (vi) in *climate zone* 1, 2 and 3, satisfy (i) or (ii) for the top storey, if the building or part of the building is two storey and—
- (A) constructed of single leaf masonry not less than 140 mm thick; or
 - (B) the lower storey of the building or part is constructed of single leaf masonry not less than 140 mm thick.

Notes

- 1 For a single storey house of single leaf masonry, either (i) or (ii) must be used.
- 2 For two storey houses with the upper storey external walls of lightweight construction and the lower storey of single leaf masonry, the upper storey must comply with (i) or (ii). The lower storey needs nothing.
- 3 For a two storey house with only single leaf masonry external walls, the upper storey must comply with (i) or (ii). The lower storey needs nothing.
- 4 For a two storey house with external walls of lightweight construction, both storeys must comply with (i) or (ii).

Table 3.12.1.3 WALLS—MINIMUM TOTAL R-VALUE FOR EACH CLIMATE ZONE

<i>Climate zones</i>	1, 2, 3 and 5	4 and 6	7	8
Minimum Total R-Value	1.4	1.7	1.9	2.8

STATE AND TERRITORY VARIATIONS

In Queensland Table 3.12.1.3 is replaced with the following :

Table 3.12.1.3 WALLS—MINIMUM TOTAL R-VALUE FOR EACH CLIMATE ZONE

<i>Climate zones</i>	1, 2 and 3	5
Minimum Total R-Value	1	1.4

- (b) The requirements of (a) do not apply in the following cases:
- (i) Walls facing the south orientation sector of [Figure 3.12.2.1](#), in *climate zones* 1, 2 and 3 south of latitude 20° south.
 - (ii) Opaque non-glazed openings in *external walls* such as doors (including garage doors), vents, penetrations, shutters and the like.

Figure 3.12.1.2

MEASUREMENT OF BUILDING PROJECTION FOR WALL SHADING

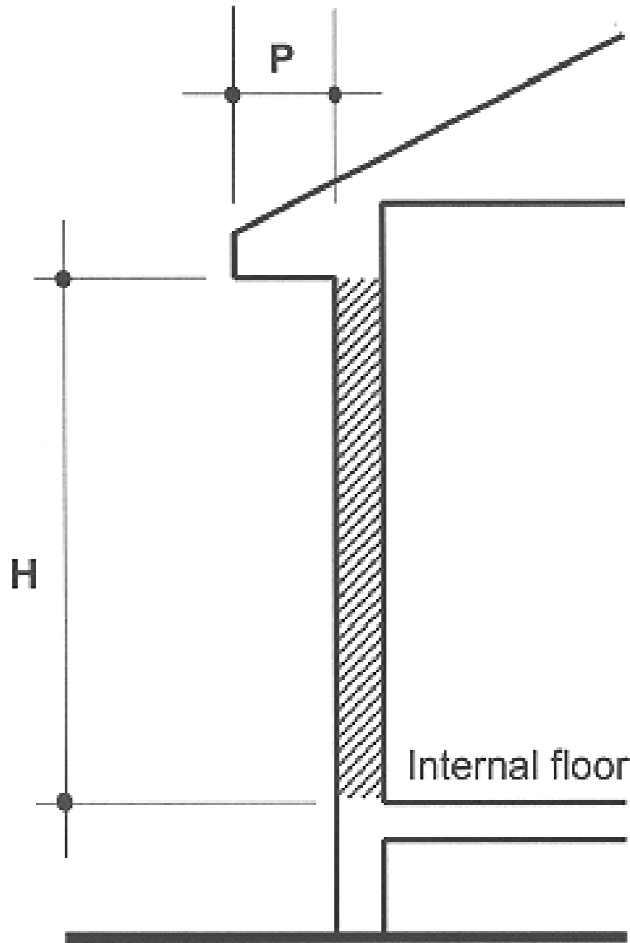

Projection (P) must be no less than one quarter (1/4) of the wall height (H) measured from the internal floor level to the underside of the projection.

Explanatory information:

Gutters can only be considered as providing shading if attached to a building projection such as a verandah, fixed canopy, eaves, shading hood, balcony or the like.

(c) A wall is deemed to have the *Total R-Value* required by [Table 3.12.1.3](#) for the relevant *climate zone* if it complies with the appropriate construction in [Figure 3.12.1.3](#).

Figure 3.12.1.3 TYPICAL INSULATION OPTIONS FOR TYPICAL WALL CONSTRUCTION					
Climate zones		1, 2, 3 and 5	4 and 6	7	8
Minimum required Total R-Value for walls		1.4	1.7	1.9	2.8
Typical wall construction R-Values					
(a)	Weatherboard (minimum 70 mm frame)	<i>Total R-Value</i> of wall materials	0.47		
		Minimum added <i>R-Value</i> of insulation	0.93	1.23	1.43
(b)	Cement and metal sheet (minimum 70 mm frame)	<i>Total R-Value</i> of wall materials	0.4		
		Minimum added <i>R-Value</i> of insulation	1.0	1.3	1.5
(c)	Clay masonry veneer (minimum 110 mm external masonry)	<i>Total R-Value</i> of wall materials	0.54		
		Minimum added <i>R-Value</i> of insulation	0.86	1.16	1.36
(d)	Concrete blockwork masonry (minimum 140 mm masonry)	<i>Total R-Value</i> of wall materials	0.52		
		Minimum added <i>R-Value</i> of insulation	0.88	1.18	1.38
(a)	Weatherboard	(b)	Cement sheet		
					

Figure 3.12.1.3 TYPICAL INSULATION OPTIONS FOR TYPICAL WALL CONSTRUCTION						
Climate zones		1, 2, 3 and 5	4 and 6	7	8	
(c)	Clay masonry veneer	(d)	Concrete blockwork masonry			
<p style="text-align: right;"><u>Wall materials</u> External masonry Studs & noggings Plasterboard</p> <p style="text-align: right;"><u>Added R-Value options</u> Sheet insulation Insulation</p>		<p style="text-align: right;"><u>Wall materials</u> External masonry Wall batten or furring channel Plasterboard</p> <p style="text-align: right;"><u>Added R-Value options</u> Insulation</p>				
(e)	Cavity clay masonry (minimum 110 mm external, minimum 90 mm internal)	<i>Total R-Value of wall materials</i>	0.67			
		<i>Minimum added R-Value of insulation</i>	0.73	Refer to 3.12.1.4(a)(iii), (iv) and (v)		
(f)	External insulated clay masonry (minimum 110 mm masonry)	<i>Total R-Value of wall materials</i>	0.5			
		<i>Minimum added R-Value of insulation</i>	0.9	1.2	1.4	2.3
(g)	Externally insulated concrete masonry (minimum 140 mm masonry)	<i>Total R-Value of wall materials</i>	0.48			
		<i>Minimum added R-Value of insulation</i>	0.92	1.22	1.42	2.32
(h)	Autoclaved aerated concrete masonry (minimum 200 mm thick, minimum 500 kg/m ³ density)	<i>Total R-Value of wall materials</i>	1.73			
		<i>Minimum added R-Value of insulation</i>	Nil	Nil	0.17	1.07

Figure 3.12.1.3 TYPICAL INSULATION OPTIONS FOR TYPICAL WALL CONSTRUCTION				
<i>Climate zones</i>	1, 2, 3 and 5	4 and 6	7	8
Typical wall construction diagrams (minimum dimensions nominated)				
(e)	Cavity clay masonry	(f)	External insulated clay masonry	
(g)	Externally insulated concrete masonry	(h)	Autoclaved aerated concrete masonry	

STATE AND TERRITORY VARIATIONS

In Queensland Figure 3.12.1.3 is amended as follows:

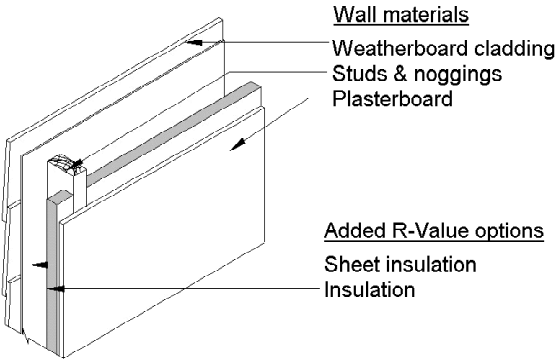
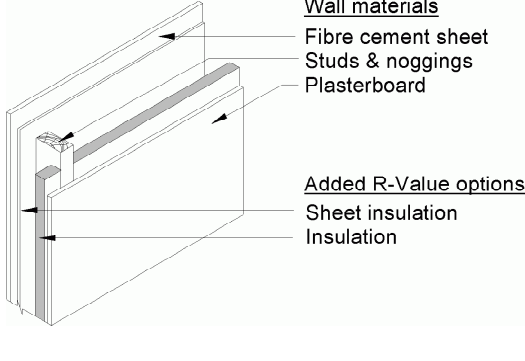
Figure 3.12.1.3 TYPICAL INSULATION OPTIONS FOR TYPICAL WALL CONSTRUCTION

<i>Climate zones</i>		1, 2 and 3	5
Minimum required Total R-Value for walls		1.0	1.4
Typical wall construction R-Values			
(a)	Weatherboard (minimum 70 mm frame)	<i>Total R-Value of wall materials</i>	0.47
		<i>Minimum added R-Value of insulation</i>	0.53 0.93
(b)	Cement and metal sheet (minimum 70 mm frame)	<i>Total R-Value of wall materials</i>	0.4
		<i>Minimum added R-Value of insulation</i>	0.60 1.0
(c)	Clay masonry veneer (minimum 110 mm external masonry)	<i>Total R-Value of wall materials</i>	0.54
		<i>Minimum added R-Value of insulation</i>	0.46 0.86
(d)	Concrete blockwork masonry (minimum 140 mm masonry)	<i>Total R-Value of wall materials</i>	0.52
		<i>Minimum added R-Value of insulation</i>	0.48 Refer to Qld 3.12.1.4(a) (vi) 0.88
(a)	Weatherboard	(b)	Cement sheet

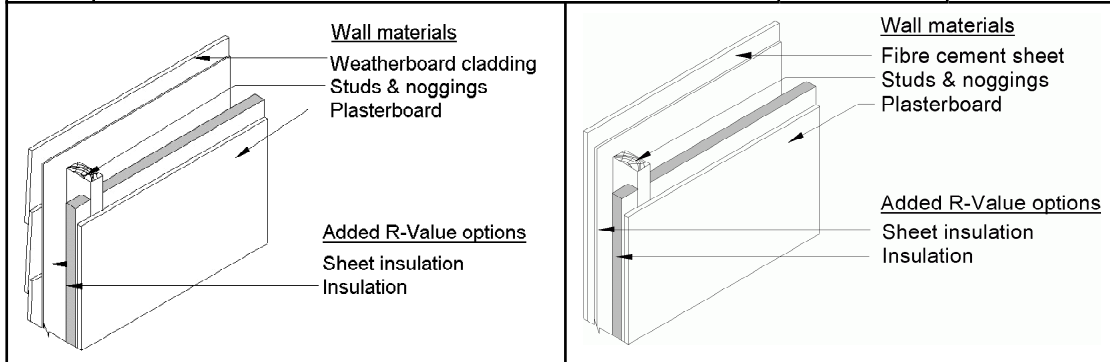
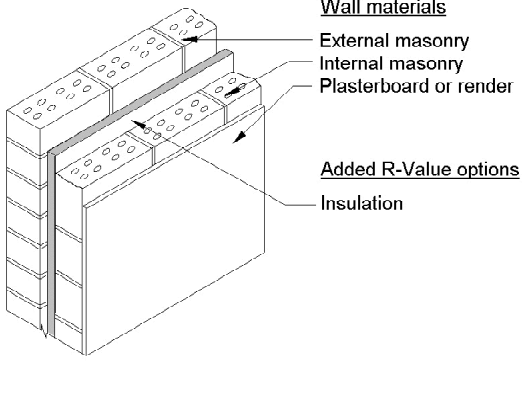
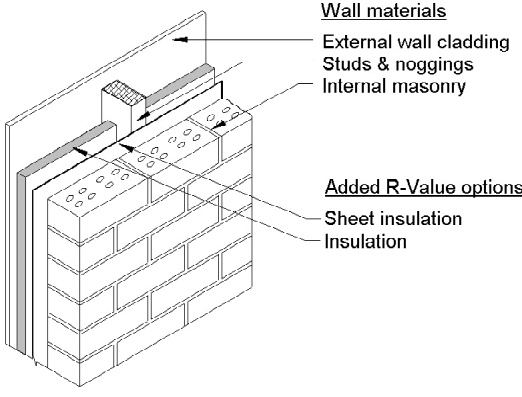
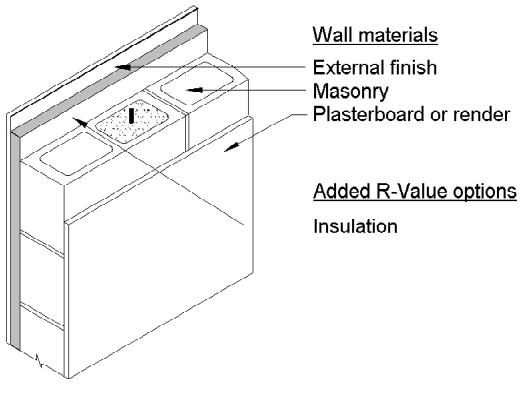
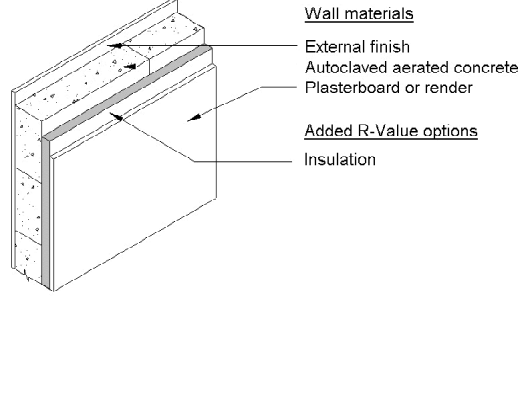

Figure 3.12.1.3 TYPICAL INSULATION OPTIONS FOR TYPICAL WALL CONSTRUCTION

<i>Climate zones</i>		1, 2 and 3	5
(c)	Clay masonry veneer	(d)	Concrete blockwork masonry
<p style="text-align: center;"><i>Wall materials</i> External masonry Studs & noggings Plasterboard</p> <p style="text-align: center;"><i>Added R-Value options</i> Sheet insulation Insulation</p>		<p style="text-align: center;"><i>Wall materials</i> External masonry Wall batten or furring channel Plasterboard</p> <p style="text-align: center;"><i>Added R-Value options</i> Insulation</p>	
(e)	Cavity clay masonry (minimum 110 mm external, minimum 90 mm internal)	<i>Total R-Value of wall materials</i>	0.67
		Minimum added <i>R-Value</i> of insulation	0.33
			0.73 Refer to 3.12.1.4 (a)(iii)
(f)	Externally insulated clay masonry (minimum 110 mm masonry)	<i>Total R-Value of wall materials</i>	0.5
		Minimum added <i>R-Value</i> of insulation	0.50
			0.90
(g)	Externally insulated concrete masonry (minimum 140 mm masonry)	<i>Total R-Value of wall materials</i>	0.48
		Minimum added <i>R-Value</i> of insulation	0.52
			0.92
(h)	Autoclaved aerated concrete masonry (minimum 200 mm thick, minimum 500 kg/m ³ density)	<i>Total R-Value of wall materials</i>	1.73
		Minimum added <i>R-Value</i> of insulation	Nil
			Nil

Figure 3.12.1.3 TYPICAL INSULATION OPTIONS FOR TYPICAL WALL CONSTRUCTION

Climate zones		1, 2 and 3	5
(e)	Cavity clay masonry	(f)	External insulated clay masonry
			
(g)	Externally insulated concrete masonry	(h)	Autoclaved aerated concrete masonry
			

Explanatory information:

1. **Figure 3.12.1.3** provides examples of typical insulation locations in various types of wall construction. The *Total R-Value required* is achieved by adding the *R-Value* of the basic wall and the *R-Value* of any additional insulation incorporated. The *Total R-Value* of the typical wall construction has been arrived at by adding together the *R-Values* for outdoor air film, wall cladding, wall air space, internal lining and internal air film.
2. *Reflective insulation* with one reflective surface having an emittance of not more than outwards is considered to achieve the following *R-Values* when used in conjunction with the *Total R-Value* of a wall construction, as described in **Figure 3.12.1.3**. The actual *R-Value* added by *reflective insulation* should be determined for each product in accordance with the standards prescribed in 3.12.1.1(d), which take into consideration factors such as the number of adjacent air spaces, dimensions of the adjacent air space, whether the space is ventilated and the presence of an anti-glare coating.

Wall construction	Reflective air space details	<i>R-Value</i> added by <i>reflective insulation</i>
Concrete masonry with internal plasterboard on battens	One 20 mm reflective air space located between <i>reflective insulation</i> and plasterboard	0.38
Cement sheet (70 mm frame with internal plaster lining)	One 70 mm reflective air space located between <i>reflective insulation</i> and plasterboard	0.42
Clay masonry veneer (70 mm timber frame with internal plaster lining)	a. One 70 mm reflective air space located between <i>reflective insulation</i> and plasterboard; and b. One 25 mm anti-glare air space located between <i>reflective insulation</i> and masonry	0.67

3. The width for any reflective air spaces adjacent to *reflective insulation* will not override other Housing Provisions such as minimum cavity requirements for masonry waterproofing.
4. Where a diagram shows *reflective insulation* or insulation, these are indicative only and neither may be necessary in some climates with some materials while in other cases *reflective insulation* or insulation may be provided separately or in combination to give the *required R-Value*.
5. For further information on *reflective insulation*, refer to the explanatory information accompanying [Figure 3.12.1.1](#).
6. A minimum thickness of 70 mm is stated for framing. In some cases, the frame thickness may need to be increased to avoid compressing the bulk insulation and thus reducing its *R-Value*.
7. Walls with a surface density of 220 kg/m² or more are deemed to achieve acceptable levels of thermal performance in certain *climate zones* due to their ability to store heat and therefore slow the heat transfer through the building *fabric*. These walls are defined by surface density (kg/m²) to reduce the complexity when measuring mass walls with voids.

The following are examples of some typical wall constructions that achieve a surface density of 220 kg/m²:

- (a) Two leaves each of 90 mm thick or greater clay or concrete masonry.
- (b) 140 mm thick or greater dense-weight hollow concrete or clay blocks with—
 - (i) 10 mm plasterboard or render; and
 - (ii) at least one concrete grouted horizontal bond beam; and
 - (iii) vertical cores filled with concrete grout at centres not exceeding 1000 mm.
- (c) 140 mm thick or greater concrete wall panels and dense-weight hollow concrete or clay blocks with all vertical cores filled with concrete grout.
- (d) 190 mm thick or greater dense-weight hollow concrete or clay blocks with—
 - (i) at least one concrete grouted horizontal bond beam; and
 - (ii) vertical cores filled with concrete grout at centres not exceeding 1800 mm.
- (e) Earth-wall construction with a minimum wall thickness of 200 mm.

3.12.1.5 Floors

- (a) A suspended floor—
- (i) with an unenclosed perimeter must have a *Total R-Value*—
 - (A) in *climate zones* 6 and 7, of not less than 1; and
 - (B) in *climate zone* 8, of not less than 2.5; or
 - (ii) with a heated slab must be insulated at the perimeter and underneath the slab with insulation having a minimum *R-Value* of not less than 1.0.

Explanatory information:

1. An unenclosed perimeter means that the sub-floor is not enclosed by ground-to-floor cladding such as masonry or cement sheet.
2. The ground-to-floor cladding can have the *required* sub-floor vents and still be considered enclosed.

- (b) A floor is deemed to have the *Total R-Value required* by (a)(i) for the relevant *climate zone* if it complies with the appropriate construction in **Figure 3.12.1.4**.

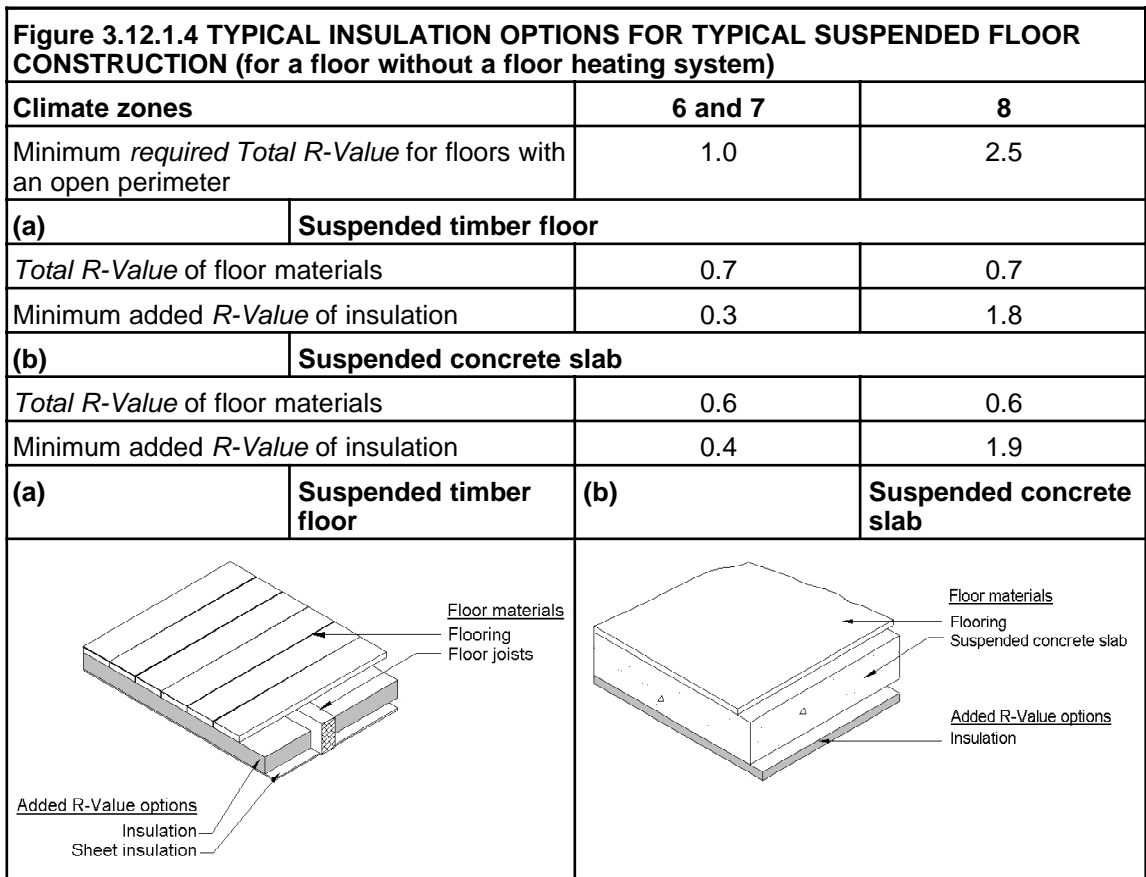

Explanatory information:

1. **Figure 3.12.1.4** provides examples of typical locations for insulation in two types of suspended floor construction. The *Total R-Value required* is achieved by adding the *R-Value* of the basic floor and the *R-Value* of any additional insulation that is incorporated.
2. The construction details depicted in **Figure 3.12.1.4** are some of the more commonly used floor construction methods and indicate how to achieve the *required Total R-Value* for building elements.
3. Any non-reflective membrane fixed between or under floor joists is considered to add an *R-Value* of 0.2 to the *Total R-Value* of the base construction in **Figure 3.12.1.4**. *Reflective insulation* will achieve a higher value and will need to be determined for each product in accordance with the standards prescribed in subclause 3.12.1.1(d).
4. *Reflective insulation* sheet should be installed with due consideration of condensation in some *climate zones* and associated interaction with adjoining building materials.
5. For further information on *reflective insulation*, refer to the explanatory information accompanying **Figure 3.12.1.1**.

(c) A concrete slab-on-ground—

- (i) with an in-slab heating system; or
- (ii) in *climate zone* 8,

must have insulation installed around the vertical edge of its perimeter.

(d) Insulation required by (c) must—

- (i) have an R-Value of not less than 1.0; and
- (ii) be water resistant; and
- (iii) be continuous from the adjacent finished surface level—
 - (A) to a depth of 300 mm; or
 - (B) for the full extent of the vertical edge of the concrete slab-on-ground (see **Figure 3.12.1.5**).

Explanatory information:

An under-tile or in-screed heating system in a bathroom, amenity area or the like, is not considered to be an in-slab system.

Figure 3.12.1.5
INSULATION OF SLAB EDGE

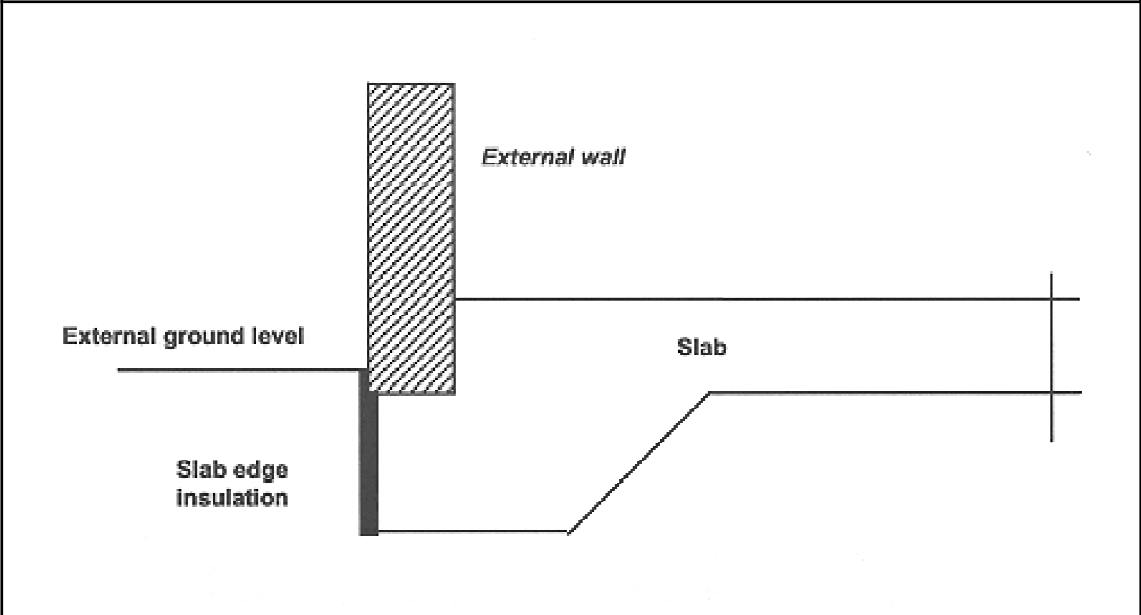

Note:

Care should be taken to ensure that any *required* termite management system is not compromised by slab edge insulation. In particular the inspection distance should not be reduced or concealed behind the insulation.

3.12.1.6 Attached Class 10a buildings

A Class 10a building attached to a Class 1 building must—

- (a) have an external *fabric* that achieves the *required* level of thermal performance for a Class 1 building; or
- (b) be separated from the Class 1 building with construction having the *required* level of thermal performance for the Class 1 building; or
- (c) provide the level of thermal performance *required* for the external element of the Class 1 building.

Explanatory information:

The attachment of a Class 10a building, such as a garage, glasshouse, solarium, pool enclosure or the like should not compromise the thermal performance of the Class 1 building. In addition, the Class 10a building may be insulated or have inherent insulating characteristics that assist the Class 1 building achieve the *required* thermal performance.

The following are examples of a Class 1 building with an attached Class 10a garage.

In (a), the thermal performance *required* for the Class 1 building may be achieved by the outside walls and floor of the Class 10a garage.

In (b), the thermal performance *required* for the Class 1 building may be achieved by the walls and floor of the Class 1 building as if the Class 10a garage is an under floor space with an enclosed perimeter.

In (c), the thermal performance *required* for the Class 1 building may be achieved by adding the thermal performance of the internal and external elements of the Class 10a garage along the heat flow paths.

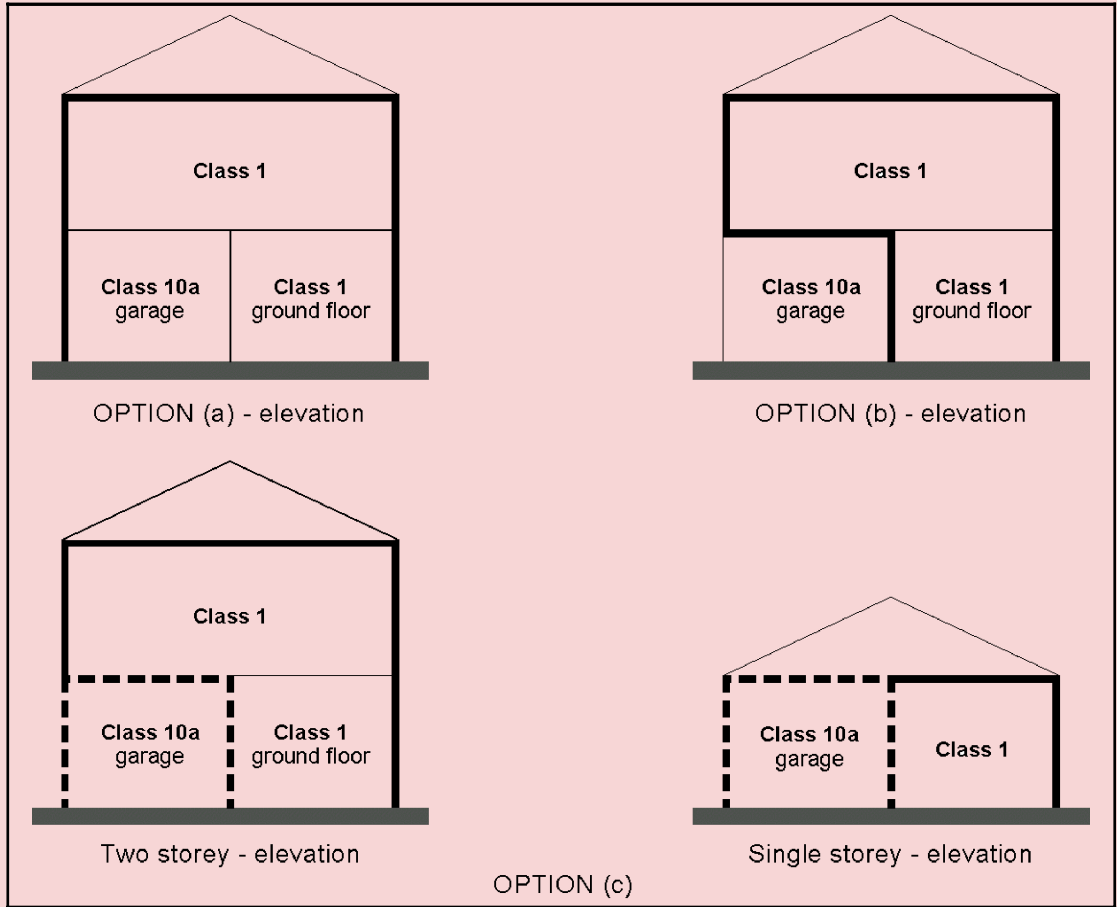

PART 3.12.2 EXTERNAL GLAZING

3.12.2 Application

This Part applies to—

- (a) a Class 1 building; and
- (b) a Class 10a building with a *conditioned space*.

Acceptable construction practice

3.12.2.1 External glazing

- (a) The effective *glazing* area for each storey of a building must not exceed the percentages in [Table 3.12.2.1](#).
- (b) When determining the requirements of (a):
 - (i) The effective *glazing* area is calculated from the total glazed area of all *windows* (excluding *roof lights*) in the storey.
 - (ii) Any *glazing* facing the north orientation sector, as defined in [Figure 3.12.2.1](#), may be halved.
 - (iii) For a building with more than one glazing type or shading projection, the maximum effective glazing is—
 - (A) the lowest value obtained by applying each glazing type and shading projection to [Table 3.12.2.1](#); or
 - (B) determined by modifying the values in [Table 3.12.2.1](#) in proportion to the amount of each particular glazing type or shading projection.

Explanatory information:

Following are examples of the application and use of 3.12.2.1(b)(iii)(B)

Example 1:

A house in *climate zone 1* has three quarters of its effective *glazing* area consisting of **single clear glass** and one quarter consisting of **5 mm toned glass** (all *glazing* has UPVC frames and is shaded by 300 mm eaves). The maximum effective *glazing* area is therefore three quarters of 23% plus one quarter of 30% (which equals 24.75%).

Example 2:

A house in *climate zone 5* has two thirds of its effective *glazing* area shaded by **600 mm eaves** and one third **unshaded** (all *glazing* has single clear glass and timber frames). The maximum effective *glazing* area is therefore two thirds of 40% plus one third of 28% (which equals 36%).

Example 3:

A house in *climate zone 3* has three quarters of its effective *glazing* area consisting of **5 mm toned glass** shaded by **450 mm eaves** and one quarter consisting of **single clear glass** shaded by a **900 mm pergola** (all *glazing* has aluminium standard frames). The maximum effective *glazing* area is therefore three quarters of 24% plus one quarter of 23% (which equals 23.75%).

Figure 3.12.2.1

ORIENTATION SECTOR

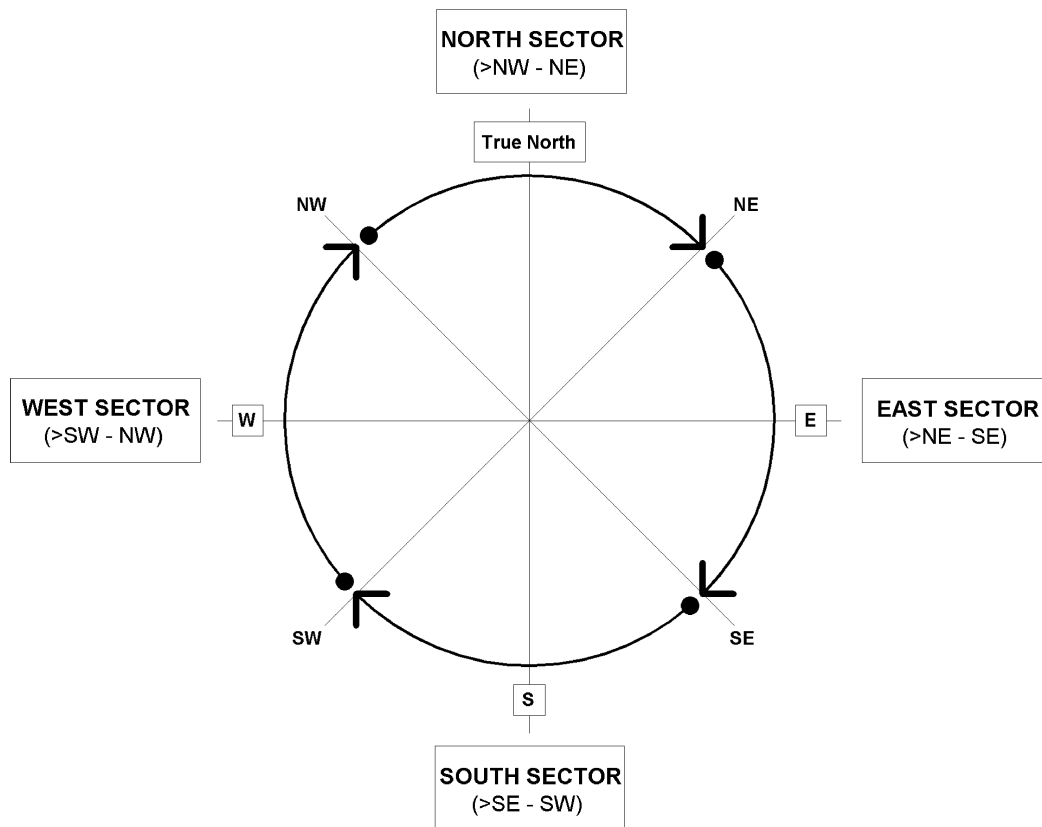

Note:

A building wall, including the *glazing* it contains, is considered to face north if it faces any direction in the north orientation sector of **Figure 3.12.2.1**. The orientations of other walls, including the *glazing* they contain, are determined in a similar way.

Explanatory information:

Orientation sectors described in **Figure 3.12.2.1** are based on true north (not magnetic north) and are as follows:

North sector is between north west (more than 315 degrees) and north east (45 degrees).

East sector is between north east (more than 45 degrees) and south east (135 degrees).

South sector is between south east (more than 135 degrees) and south west (225 degrees).

West sector is between south west (more than 225 degrees) and north west (315 degrees).

3.12.2.2 Shading

- (a) Where shading is *required* to comply with [Table 3.12.2.1](#), it must—
 - (i) be provided to external *glazing* on walls—
 - (A) for locations north of latitude 20° south—on all sides of the building; and
 - (B) for locations south of latitude 20° south—facing the north, east and west orientation sectors as described in [Figure 3.12.2.1](#); and
 - (ii) be provided by—
 - (A) a shading projection complying with (b); or
 - (B) a shading device complying with (c); or
 - (C) a combination of both.
- (b) A shading projection must—
 - (i) be a permanent feature including—
 - (A) a verandah, balcony, fixed canopy, eaves, shading hood or the like; or
 - (B) a Class 10 building such as a carport or the like; and
 - (ii) be no less than the distance in [Table 3.12.2.1](#) measured horizontally from the face of the building.
- (c) A shading device must—
 - (i) restrict at least 80% of the solar radiation when fully closed or lowered; and
 - (ii) be a shutter, blind, vertical or horizontal building screen with blades, battens, slats or the like; and
 - (iii) if adjustable, be readily operated either manually, mechanically or electronically by the building occupants.

Explanatory information:

1. Shading of the south side is optional except for tropical locations (north of latitude 20 degrees south) where the shading must be provided to all sides of the building. Shading on the south side by a building projection is ineffective south of the tropics.
2. Shading devices can include fixed louvres, shading screens and other types of perforated or fixed angle slatted shades. However, such devices need to be designed for the climate and latitude to ensure that summer sun penetration is restricted, while winter sun access is achieved.
3. Gutters can only be considered as providing shading if attached to a building projection such as a verandah, fixed canopy, eaves, shading hood, balcony or the like.
4. Shading devices can be either attached or located adjacent to the building in a manner so as to provide the *required* level of shading in [Table 3.12.2.1](#).
5. Where the *glazing* area exceeds that in [Table 3.12.2.1](#), the building including the *glazing* can be designed in accordance with the *Verification Method* V2.6. This approach is also suitable for alternative *glazing* thermal performance systems such as applied films.

Figure 3.12.2.2

TYPICAL SHADING PROJECTIONS AND DEVICES FOR EXTERNAL GLAZING

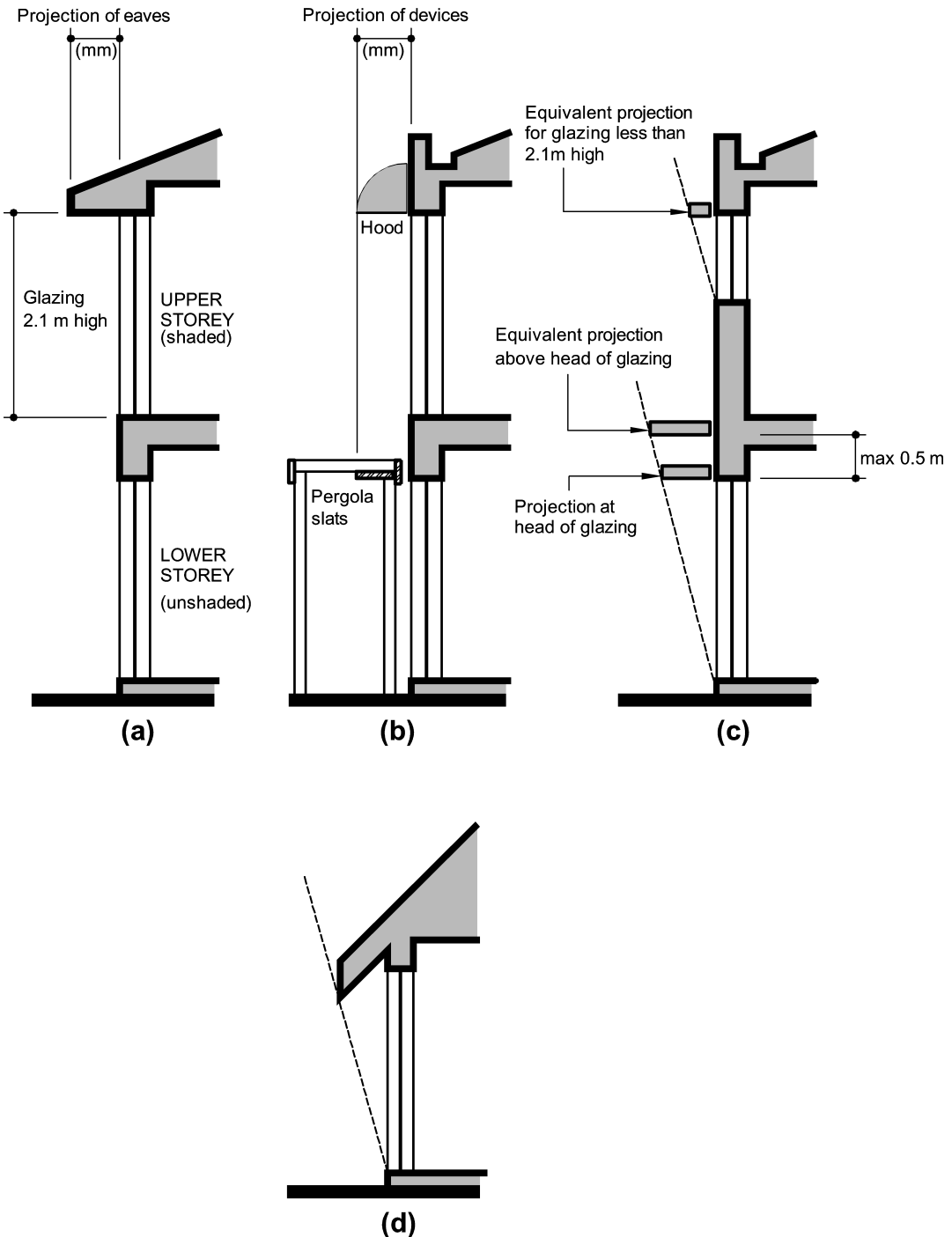

Notes:

1. All dotted lines in (c) and (d) are parallel.

Figure 3.12.2.2
TYPICAL SHADING PROJECTIONS AND DEVICES FOR EXTERNAL GLAZING
2. The shading projections in all of the examples above are equivalent.

Table 3.12.2.1 MAXIMUM EFFECTIVE GLAZING AREA (Percentage of total *glazing* area to the total *floor* area of the *storey*)

Glass description	Glazing frame	Glazing system performance characteristics (maximum <i>U-Value</i> /SHGC)	Maximum effective <i>glazing</i> area percentage				
			No shading	Shading (projection from face of building (mm))			
				300	450	600	900
CLIMATE ZONE 1							
Single clear	Aluminium standard	5.6/0.86	18	21	22	24	27
	Timber or UPVC	4.6/0.78	19	23	24	26	30
Toned (minimum 5 mm)	Aluminium standard	5.6/0.66	23	27	29	31	36
	Timber or UPVC	4.5/0.59	26	30	32	35	40
Single solar control, pyrolytic low-e	Aluminium standard	4.1/0.48	31	37	40	43	49
	Aluminium thermally improved	3.3/0.46	33	38	41	45	51
	Timber or UPVC	3.2/0.47	32	38	41	44	50
CLIMATE ZONE 2							
Single clear	Aluminium standard	5.6/0.86	26	31	34	37	39
	Timber or UPVC	4.6/0.78	29	35	37	40	46
Toned (minimum 5 mm)	Aluminium standard	5.6/0.66	34	39	39	39	39
	Timber or UPVC	4.5/0.59	38	46	48	48	48

Glass description	Glazing frame	Glazing system performance characteristics (maximum U-Value/SHGC)	Maximum effective glazing area percentage				
			No shading	Shading (projection from face of building (mm))			
				300	450	600	900
Single solar control, pyrolytic low-e	Aluminium standard	4.1/0.48	47	53	53	53	53
	Aluminium thermally improved	3.3/0.46	49	59	63	66	66
	Timber or UPVC	3.2/0.47	48	57	62	67	68
CLIMATE ZONE 3							
Single clear	Aluminium standard	5.6/0.86	15	17	19	20	23
	Timber or UPVC	4.6/0.78	16	19	21	22	26
Toned (minimum 5 mm)	Aluminium standard	5.6/0.66	19	23	24	26	30
	Timber or UPVC	4.5/0.59	22	25	27	29	34
Single solar control, pyrolytic low-e	Aluminium standard	4.1/0.48	26	31	33	36	42
	Aluminium thermally improved	3.3/0.46	28	33	35	38	43
	Timber or UPVC	3.2/0.47	27	32	34	37	42
CLIMATE ZONE 4							
Single clear	Aluminium standard	5.6/0.86	19	23	24	24	24
	Timber or UPVC	4.6/0.78	21	25	27	29	29
Toned (minimum 5 mm)	Aluminium standard	5.6/0.66	24	24	24	24	24
	Timber or UPVC	4.5/0.59	28	30	30	30	30

Glass description	Glazing frame	Glazing system performance characteristics (maximum U-Value/SHGC)	Maximum effective glazing area percentage				
			No shading	Shading (projection from face of building (mm))			
				300	450	600	900
Single solar control, pyrolytic low-e	Aluminium standard	4.1/0.48	33	33	33	33	33
	Aluminium thermally improved	3.3/0.46	35	41	41	41	41
	Timber or UPVC	3.2/0.47	35	41	43	43	43
CLIMATE ZONE 5							
Single clear	Aluminium standard	5.6/0.86	26	31	34	34	34
	Timber or UPVC	4.6/0.78	28	35	37	40	40
Toned (minimum 5 mm)	Aluminium standard	5.6/0.66	34	34	34	34	34
	Timber or UPVC	4.5/0.59	38	43	43	43	43
Single solar control, pyrolytic low-e	Aluminium standard	4.1/0.48	46	47	47	47	47
	Aluminium thermally improved	3.3/0.46	48	58	58	58	58
	Timber or UPVC	3.2/0.47	47	57	60	60	60
CLIMATE ZONE 6							
Single clear	Aluminium standard	5.6/0.86	28	28	28	28	28
	Timber or UPVC	4.6/0.78	33	34	34	34	34
3/12/3 clear IG with air fill	Aluminium standard	3.6/0.77	33	40	43	43	43
	Aluminium thermally improved	2.8/0.67	38	46	50	55	56

Glass description	Glazing frame	Glazing system performance characteristics (maximum U-Value/SHGC)	Maximum effective glazing area percentage				
			No shading	Shading (projection from face of building (mm))			
				300	450	600	900
	Timber or UPVC	2.6/0.69	37	45	49	53	60
Single solar control, pyrolytic low-e	Aluminium standard	4.1/0.48	38	38	38	38	38
	Aluminium thermally improved	3.3/0.46	47	47	47	47	47
	Timber or UPVC	3.2/0.47	49	49	49	49	49
CLIMATE ZONE 7							
Single clear	Aluminium standard	5.6/0.86	25	25	25	25	25
	Timber or UPVC	4.6/0.78	27	27	27	27	27
3/12/3 clear IG with air fill	Aluminium standard	3.6/0.77	33	33	33	33	33
	Aluminium thermally improved	2.8/0.67	38	38	38	38	38
	Timber or UPVC	2.6/0.69	37	37	37	37	37
Single solar control, pyrolytic low-e	Aluminium standard	4.1/0.48	31	31	31	31	31
	Aluminium thermally improved	3.3/0.46	38	38	38	38	38
	Timber or UPVC	3.2/0.47	39	39	39	39	39
CLIMATE ZONE 8							
Single clear	Aluminium standard	5.6/0.86	17	17	17	17	17
	Timber or UPVC	4.6/0.78	21	21	21	21	21
3/12/3 clear IG with air fill	Aluminium standard	3.6/0.77	27	27	27	27	27

Glass description	Glazing frame	Glazing system performance characteristics (maximum <i>U-Value</i> /SHGC)	Maximum effective <i>glazing</i> area percentage				
			No shading	Shading (projection from face of building (mm))			
				300	450	600	900
	Aluminium thermally improved	2.8/0.67	35	35	35	35	35
	Timber or UPVC	2.6/0.69	38	38	38	38	38
Single solar control, pyrolytic low-e	Aluminium standard	4.1/0.48	24	24	24	24	24
	Aluminium thermally improved	3.3/0.46	30	30	30	30	30
	Timber or UPVC	3.2/0.47	30	30	30	30	30
Notes:							
1.	<p>For the purpose of this Table, the floor area of the storey means the area of all floors of that storey measured over enclosing walls, and includes—</p> <p>(a) the area of a mezzanine within the storey, measured within the finished surfaces of any external walls; and</p> <p>(b) the area occupied by any <i>internal walls</i> or partitions, any cupboard, or other built-in furniture, fixture or fitting.</p> <p>A storey does not include an attached Class 10a building.</p>						
2.	Shading can be achieved by a shading projection (refer to Figure 3.12.2.2), a shading device or a combination of both (refer to 3.12.2.2). For example—eaves on two sides of a building and adjustable shading devices on the other two sides. A shading device satisfies any shading projection requirement.						
3.	UPVC means unplasticised poly-vinyl chloride.						
4.	IG means insulating glass unit (sealed double glass).						
5.	3/12/3 means double glass with a 12 mm minimum gap between 3 mm minimum thickness glass.						
6.	Shaded cells mean that although the <i>glazing</i> area is shown, the area is limited by winter heat loss considerations and so no additional <i>glazing</i> area can be obtained for the additional shading.						
7.	<i>Glazing</i> area limits for shading projections between those shown in the Table can be interpolated.						

Glass description	Glazing frame	Glazing system performance characteristics (maximum U-Value/SHGC)	Maximum effective glazing area percentage			
			No shading	Shading (projection from face of building (mm))		
				300	450	600
8.	<p>The maximum effective <i>glazing</i> area values in Table 3.12.2.1 are based on 2.1 m high <i>glazing</i> with a shading projection located at the head of the <i>glazing</i> (as in Figure 3.12.2.2(a) Upper Storey). To achieve equivalent shading where the <i>glazing</i> is more than 2.1 m high, a projection at the head of the <i>glazing</i> must be increased in proportion to the greater height of the <i>glazing</i>. Where the <i>glazing</i> is less than 2.1 m high the shading projection may be decreased in proportion to the lesser height of the <i>glazing</i>. A shading projection may be located up to 0.5 m above the head of the <i>glazing</i> (as in Figure 3.12.2(c) Lower Storey) but must be proportionally increased to achieve the equivalent shading effect.</p> <p>Example 1: A house with 300 mm eaves at the head of glazing 0.9 m high would be equivalent to a house with 700 mm eaves at the head of glazing 2.1 m high ($300 / 0.9 = 700 / 2.1$). In this instance the <i>maximum effective glazing area</i> for single clear glass in aluminium standard frames in <i>climate zone 3</i> is 21% (interpolating between the values for 600 mm and 900 mm eaves).</p> <p>Example 2: A house in <i>climate zone 3</i> has three quarters of its effective <i>glazing</i> area consisting of 0.9 m high single clear glass shaded by 300 mm eaves and one quarter consisting of 2.1 m high 5 mm toned glass shaded by a 900 mm veranda (all <i>glazing</i> has aluminium standard frames).</p> <p>Step 1- The 300 mm eaves over 0.9 m high <i>glazing</i> is equivalent to 700 mm eaves over 2.1 m high <i>glazing</i> ($300 / 0.9 = 700 / 2.1$).</p> <p>Step 2- The maximum effective <i>glazing</i> area is therefore three quarters of 21% plus one quarter of 30% (which equals 23.25%).</p>					
9.	<p>The <i>glazing</i> system must have the <i>Total U-Value</i> and Solar Heat Gain Co-efficient in this Table and be supported by evidence of suitability in accordance with Part 1.2.2. Another <i>glazing</i> system, including one using glass and film combinations, may be substituted for one in this Table provided its <i>Total U-Value</i> and Solar Heat Gain Co-efficient are not greater than those of the <i>glazing</i> system it replaces, and it is also provided by evidence of suitability in accordance with Part 1.2.2.</p>					

Explanatory information:

1. The *glazing* area limits given in [Table 3.12.2.1](#) provide only minimal protection against overheating in hot conditions and heat loss during cold conditions. Careful attention to the sizing and placement of *glazing* around the building, following design guidelines from reputable sources, will considerably improve both energy efficiency and comfort.
2. Some alternative glazing types are shown below. Note that some glazing systems may not suit certain climates. NI means “not included”.

Glass description	Values for <i>glazing</i> frame type					
	Total U-Value			SHGC		
	Aluminium standard	Aluminium thermally improved	Timber or UPVC	Aluminium standard	Aluminium thermally improved	Timber or UPVC
3/6/3 clear IG with air fill	3.9	3.1	2.9	0.77	0.67	0.69
3/12/4 pyrolytic low-e IG, argon fill	2.8	2.1	1.9	0.71	0.61	0.63
Supertoned (tinted)	5.6	NI	4.5	0.63	NI	0.56
5/6/5 toned (tinted) IG with air fill	3.9	3.0	2.9	0.56	0.48	0.49
5/12/4 supertoned low-e IG with argon fill	2.8	2.1	1.9	0.44	0.37	0.37
6/10/4 high-performance toned (tinted) low-e IG with argon fill	2.7	2.0	1.8	0.39	0.33	0.33

PART 3.12.3 BUILDING SEALING

3.12.3 Application

- (a) This Part applies to—
- (i) a Class 1 building; and
 - (ii) a Class 10a building with a *conditioned space*,
- (b) excluding the following:
- (i) A building in *climate zones* 1, 2, 3 and 5 where the only means of air-conditioning is by using an evaporative cooler.
 - (ii) A building *ventilation opening* that is necessary for the safe operation of a gas appliance.
 - (iii) A Class 10a building used for the accommodation of vehicles.

Explanatory information:

1. An evaporatively cooled building in *climate zones* 4 and 6 needs to be sealed because of the likelihood of heating being needed during colder periods.
2. Appropriate ventilation for gas appliances can be obtained from relevant legislation, reference standards and product installation manuals.

STATE AND TERRITORY VARIATIONS

In South Australia 3.12.3 is replaced with the following:

3.12.3 Application

This Part applies to a Class 1 building excluding the following:

- (a) A building where the only means of air-conditioning is by using an evaporative cooler.
- (b) A building *ventilation opening* that is necessary for the safe operation of a gas appliance.

A. Acceptable construction manual

3.12.3.0

Performance Requirement P2.6.1 is satisfied for the sealing of a *window* in a Class 1 building, if the air infiltration of the closed *window* complies with AS 2047.

B. Acceptable construction practice

3.12.3.1 Chimneys and flues

The chimney or flue of an open solid-fuel burning appliance must be provided with a damper or flap that can be closed to seal the chimney or flue.

Explanatory information:

1. The requirements of this Part are to be read in conjunction with the fire safety requirements in [Part 3.7.3](#).
2. A solid-fuel burning device is a heater that burns material such as timber, coal and the like. This clause does not apply to gas and liquid fuel burning devices.

3.12.3.2 Roof lights

- (a) A *roof light* must be sealed, or capable of being sealed, in accordance with (b) to minimise air leakage when serving—
- (i) a *conditioned space*; or
 - (ii) a *habitable room* in climate zones 4, 6, 7 and 8.
- (b) A *roof light required* by (a) to be sealed or capable of being sealed must be constructed with—
- (i) an imperforate ceiling diffuser or the like installed at the ceiling or internal lining level; or
 - (ii) a compressible seal if it is a *roof window*; or
 - (iii) a shutter system readily operated either manually, mechanically or electronically by the building occupant.

STATE AND TERRITORY VARIATIONS

3.12.3.2 does not apply in South Australia.

3.12.3.3 External windows and doors

- (a) A seal to restrict air infiltration must be fitted to each edge of an external door, openable *window* and other such opening—
- (i) when serving a *conditioned space*; or
 - (ii) in *climate zones* 4, 6, 7 and 8 when serving a *habitable room*.
- (b) An external louvre door, louvre *window* or other such opening is exempt from (a).

Explanatory information:

Requirements for the sealing of louvres are under consideration for future inclusion in the Housing Provisions. The outcome will depend on the availability of complying products.

- (c) A seal *required* by (a) may be a foam or rubber compressible strip, fibrous seal or the like.

STATE AND TERRITORY VARIATIONS

1. **In the Northern Territory 3.12.3.3 is replaced with the following:**

3.12.3.3 External doors

External swing doors serving a *conditioned* space must be fitted with a sealing device to the bottom edge of each leaf.

2. **In South Australia 3.12.3.3 is replaced with the following:**

3.12.3.3 External doors

External swing doors must be fitted with a draught protection device to the bottom edge of each leaf.

3.12.3.4 Exhaust fans

An exhaust fan must be fitted with a sealing device such as a self-closing damper, filter or the like when serving—

- (a) a *conditioned space*; or
 (b) a *habitable room* in *climate zones* 4, 6, 7 and 8.

Explanatory information:

An exhaust fan is considered to be adequately sealed if it is fitted with a filter such as the type commonly used in kitchen range hoods.

STATE AND TERRITORY VARIATIONS

3.12.3.4 does not apply in South Australia.

3.12.3.5 Construction of roofs, walls and floors

- (a) Roofs, *external walls*, external floors and any opening such as a *window*, door or the like in the external *fabric* must be constructed to minimise air leakage in accordance with (b) when forming part of the external *fabric* of—
- (i) a *conditioned space*; or
 (ii) a *habitable room* in *climate zones* 4, 6, 7 and 8.
- (b) Construction *required* by (a) must be—

- (i) enclosed by internal lining systems that are close fitting at ceiling, wall and floor junctions; or
- (ii) sealed by caulking, skirting, architraves, cornices or the like.

Explanatory information:

A close fitting internal lining system is considered to include an allowance for minimum lining thermal movement gaps at wall, floor and ceiling junctions.

STATE AND TERRITORY VARIATIONS

3.12.3.5 does not apply in South Australia.

PART 3.12.4 AIR MOVEMENT

3.12.4 Application

This Part applies to a *habitable room* in a Class 1 building.

Acceptable construction practice

3.12.4.1 Air movement

- (a) A *habitable room* must have provision for air movement in—
- (i) *climate zones* 1, 2, 3, 4 and 5, in accordance with [Table 3.12.4.1](#) provided—
 - (A) any *required ventilation opening* complies with [3.12.4.2](#) or, where ventilation cannot be provided through an *external wall*, air movement may be provided in accordance with (b); and
 - (B) in *climate zones* 1, 2, 3, 4 and 5, any *required ceiling fan* complies with [3.12.4.3](#); and
 - (C) in *climate zones* 3 and 4, any *required evaporative cooler* complies with [3.12.4.3](#); and
 - (ii) *climate zones* 6, 7 and 8, in accordance with [Part 3.8.5](#).

Explanatory information:

In humid locations, such as Darwin and Cairns, evaporative coolers would not provide the same cooling effect that they provide in dryer climates. Although they would provide some benefit from the air movement if operated in a “fan-only” mode, they would cause discomfort, possible condensation and possible mould growth if operated in an evaporative “water-on” mode. However, even though a concession is not given in *climate zones* 1, 2 and 5, there are locations, particularly in *climate zone* 5, where evaporative coolers would be effective.

- (b) Air movement may be provided through an opening from an adjoining room (including an enclosed verandah) if—
- (i) the adjoining room is not a *sanitary compartment*; and
 - (ii) the opening between the adjoining room and the *habitable room* complies with [Table 3.12.4.1](#) as if it were a *ventilation opening* to the *habitable room* or a proportion thereof if some ventilation is provided from another source; and
 - (iii) the *ventilation opening* to the adjoining room complies with [Table 3.12.4.1](#) for the total *floor area* of the adjoining room and the *habitable room*.

Table 3.12.4.1 PROVISION FOR AIR MOVEMENT FOR HABITABLE ROOMS

Climate zones	Minimum total ventilation opening area per habitable room (percentage of the floor area of the habitable room)		
	Without a ceiling fan or evaporative cooler	With a ceiling fan	With an evaporative cooler
1	15%	12.5%	15% see Note
2	10%	5%	10% see Note
3	12.5%	7.5%	7.5%
4	10%	5%	5%
5	7.5%	5%	7.5% see Note

Note:
Because evaporative coolers are less effective than ceiling fans in more humid locations, the requirement for ventilation openings in climate zones 1, 2 and 5 with an evaporative cooler is the same as without one.

STATE AND TERRITORY VARIATIONS

In Western Australia 3.12.4.1 and Table 3.12.1.4 is replaced with the following:

3.12.4.1 Air movement

- (a) A habitable room must have provision for air movement in—
- (i) climate zones 1, 2, 3, 4 and 5, in accordance with Table 3.12.4.1 provided—
 - (A) any required ventilation opening complies with 3.12.4.2 or, where ventilation cannot be provided through an external wall, air movement may be provided in accordance with (b); and
 - (B) any required ceiling fan complies with 3.12.4.3; and
 - (ii) climate zones 6, 7 and 8, in accordance with Part 3.8.5.
 - (iii) Compliance with (a) is not required for buildings located within climate zone 1 and Region D 'Severe Tropical Cyclones' as designated in AS 1170.2 or AS/NZS 1170.2, provided required roof insulation R-Values are increased by 1.5 and walls are provided with a minimum of R1.5 insulation and shaded in compliance with 3.12.1.4(a)(ii).
- (b) Air movement may be provided through an opening from an adjoining room (including an enclosed verandah) if—
- (i) the adjoining room is not a sanitary compartment; and
 - (ii) the opening between the adjoining room and the habitable room complies with Table 3.12.4.1 as if it were a ventilation opening to the habitable room or a proportion there of if some ventilation is provided from another source; and
 - (iii) the ventilation opening to the adjoining room complies with Table 3.12.4.1 for the total floor area of the adjoining room and the habitable room.

Table 3.12.4.1 PROVISION FOR AIR MOVEMENT FOR HABITABLE ROOMS

Climate zones	Minimum total ventilation opening area per habitable room (percentage of the floor area of the habitable room)	
	Without a ceiling fan	With a ceiling fan
1	15%	12.5%
3	12.5%	7.5%
2 and 4	10%	5%
5	7.5%	5%

3.12.4.2 Ventilation openings

- (a) The total *ventilation opening area* required by [Table 3.12.4.1](#) to a *habitable room* must—
- (i) be connected by a breeze path complying with (b) to another *ventilation opening* in another room or space; or
 - (ii) be provided by a minimum of two *ventilation openings* located within the same *habitable room*, with each *ventilation opening* having an area of not less than 25% of the area required by [Table 3.12.4.1](#).
- (b) A breeze path required by (a)(i) must—
- (i) pass through not more than two openings in the internal walls with each opening having an area of not less than 1.5 m²; and
 - (ii) have a distance along the breeze path between *ventilation openings* of not more than 20 m.

Explanatory information:

1. *Ventilation openings* should be designed to allow the interior of the building to take full advantage of any natural breeze. Careful consideration should be given to the type and location of openings to ensure optimum effect is achieved and that internal “dead air pockets” are avoided.
2. An opening may serve more than one breeze path.

3.12.4.3 Ceiling fans and evaporative coolers

A ceiling fan or evaporative cooler required under [Table 3.12.4.1](#) must—

- (a) be permanently fixed ; and
- (b) have a speed controller; and
- (c) for a ceiling fan, have a blade rotation diameter of not less than 900 mm.

Explanatory information:

The fan should be installed to ensure it achieves optimum performance in providing air movement for the building occupants. As a general rule a 900 mm diameter fan will serve a *floor area* of 20 m². However, this may vary depending on the various factors including the blade design, the ceiling clearance and the power of the fan.

PART 3.12.5 SERVICES

3.12.5 Application

This Part applies to—

- (a) a Class 1 building; and
- (b) a Class 10a building.

A. Acceptable construction manuals

3.12.5.0

Performance Requirement P2.6.2 for a hot water supply system is satisfied if—

- (a) the hot water supply system is designed and installed in accordance with Section 8 of AS/NZS 3500.4 or clause 3.38 of AS/NZS 3500.5; except
- (b) a solar hot water supply system in *climate zones* 1, 2 and 3 is not *required* to comply with (a).

B. Acceptable construction practice

3.12.5.1 Insulation of services

Thermal insulation for central heating water *pipng* and heating and cooling ductwork must be—

- (a) protected against the effects of weather and sunlight; and
- (b) able to withstand the temperatures within the *pipng* or ductwork.

Explanatory information:

The Acceptable Construction Manual described in [3.12.5.0](#) is for use with hot water systems that provide hot water for general domestic use in areas such as bathrooms, kitchens, laundries and the like.

The central heating water *pipng* provisions apply to hot water systems designed to heat the building.

3.12.5.2 Central heating water piping

Central heating water *pipng* that is not within a *conditioned space* must be thermally insulated to achieve the minimum *Total R-Value* in accordance with [Table 3.12.5.1](#).

Table 3.12.5.1 CENTRAL HEATING WATER PIPING—MINIMUM THERMAL INSULATION

<i>Piping to be insulated</i>		Minimum <i>Total R-Values</i> for each <i>climate zone</i>		
		1, 2, 3 and 5	4, 6 and 7	8
1.	Internal <i>piping</i>			
	(a)	All flow and return <i>piping</i> that is—		0.2
		(i)	within an unventilated wall space; or	
		(ii)	within an internal floor between storeys; or	
		(iii)	between ceiling insulation and a ceiling.	
	(b)	All hot water <i>piping</i> encased within a concrete floor slab (except that which is part of a floor heating system).		0.2
	0.2			
2.	<i>Piping</i> located within a ventilated wall space, an enclosed building sub-floor or a roof space			
	(a)	All flow and return <i>piping</i> .		0.3
	(b)	Cold water supply <i>piping</i> —within 500 mm of the connection to the central water heating system.		
	(c)	Relief valve <i>piping</i> —within 500 mm of the connection to the central water heating system.		
				0.45
				0.6

<i>Piping to be insulated</i>			Minimum <i>Total R-Values</i> for each climate zone		
			1, 2, 3 and 5	4, 6 and 7	8
3.	<i>Piping located outside the building or in an unenclosed building sub-floor or roof space</i>				
	(a)	All flow and return <i>piping</i> .	0.3	0.6	0.6
	(b)	Cold water supply <i>piping</i> —within 500 mm of the connection to the central water heating system.			
	(c)	Relief valve <i>piping</i> —within 500 mm of the connection to the central water heating system.			

Explanatory information:

1. The insulation levels in the following table are typical examples of materials that can be used to insulate central heating water *piping*. Other methods are available for meeting the *Total R-Values* required by [Table 3.12.5.1](#).
2. *Piping* within a timber member, such as that passing through a wall stud, is considered to have sufficient insulation for the purposes of [Table 3.12.5.1](#).

Insulation	<i>Total R-Value</i>
9 mm of closed cell polymer	0.2
13 mm of closed cell polymer	0.3
19 mm of closed cell polymer	0.45
25 mm of closed cell polymer	0.6

3.12.5.3 Heating and cooling ductwork

- (a) Heating and cooling ductwork and fittings must—
- (i) be thermally insulated to achieve the minimum *Total R-Value* in accordance with [Table 3.12.5.2](#) for the relevant *climate zone*; and
 - (ii) use thermal insulation material in accordance with—
 - (A) AS/NZS 4859.1; or
 - (B) AS 2464.5 for determining thermal transmission properties by means of a heat flow meter; or
 - (C) AS 2464.6 for determining thermal transmission properties by means of a guarded hot plate; and

Explanatory information:

AS/NZS 4859 Part 1 supersedes AS 2464 Parts 5 and 6. To provide industry time to adjust to AS/NZS 4859 Part 1, sub-clause 3.12.5.3 (a)(ii) allows the use

of either standard.

- (iii) be sealed against air loss—
 - (A) by closing all openings in the surface, joints and seams of ductwork with adhesives, mastics, sealants or gaskets in accordance with AS 4254 for a Class C seal; or
 - (B) for flexible ductwork, with a sealant and draw band encased with adhesive tape.
- (b) Duct insulation located under a suspended floor, in an attached Class 10a building and in a roof space must—
 - (i) be protected by an outer sleeve of protective sheeting to prevent the insulation becoming damp; and
 - (ii) have the outer protective sleeve sealed with adhesive tape not less than 48 mm wide creating an airtight and waterproof seal.
- (c) The requirements of (a) do not apply to heating and cooling ductwork and fittings located within the insulated building *envelope* including a service riser within the *conditioned space*, internal floors between storeys and the like.

Explanatory information:

Ductwork within a fully insulated building may still benefit from insulation particularly when the system is only operating for short periods.

In some *climate zones* condensation may create problems with uninsulated ductwork and insulation should still be considered.

Table 3.12.5.2 HEATING AND COOLING DUCTWORK—MINIMUM THERMAL INSULATION

Location and element			Minimum <i>Total R-Value</i> for ductwork for each <i>climate zone</i>			
			Evaporative cooling	Heating system or Refrigerated cooling system		
				All <i>climate zones</i>	1, 3, 4, 6 and 7	2 and 5
1.	Under enclosed suspended floors	Ductwork	0.6	1.0	1.0	1.5
2.	Roof spaces	Metal heating fittings	0.1	0.1	0.1	0.1
3.	External to the building	Ductwork	0.6	1.5	1.0	1.5
4.	Under open suspended floors					

Explanatory information:

1. Insulation for refrigerated cooling ductwork should have a vapour barrier to prevent possible damage by condensation.
2. The insulation levels in the following table are typical examples of materials that can be used to insulate ductwork and fittings. Other methods are available for meeting the *Total R-Values* required by [Table 3.12.5.2](#).
3. The addition of foil backing to the insulation and plastic protective sheeting is not considered to change the *Total R-Values* in the following table unless supported by appropriate documentary evidence.
4. Any flexible ductwork used for the transfer of products, initiating from a heat source that contains a flame, must also have the fire hazard properties required by [3.7.1.9](#).

Insulation	<i>Total R-Value</i>
4 mm closed cell polymer	R0.1
8 mm polyurethane spray	R0.1
40 mm polyester fibre insulation (250 g/m ²)	R0.6
70 mm polyester fibre insulation (450 g/m ²)	R1.0
90 mm polyester fibre insulation (800 g/m ²)	R1.5
25 mm mineral wool or fibreglass insulation (480 g/m ²)	R0.6
38 mm mineral wool or fibreglass insulation (560 g/m ²)	R1.0
50 mm mineral wool or fibreglass insulation (840 g/m ²)	R1.5

STATE AND TERRITORY ADDITIONS

Australian Capital Territory

New South Wales

Northern Territory

Queensland

South Australia

Tasmania

Victoria

Western Australia

SUPERSEDED
STATE AND TERRITORY ADDITIONS

APPENDIX A CONTENTS

APPENDIX A STATE AND TERRITORY ADDITIONS

CONTENTS

AUSTRALIAN CAPITAL TERRITORY

Structure

ACT 1 * * * * *

Health and amenity

ACT 2 Hazardous materials

ACT 3 Control of Litter on Building Sites

ACT 4 Waste Management

ACT 5 Energy Efficiency

Safe movement and access

ACT 6 Swimming pools

AUSTRALIAN CAPITAL TERRITORY
ADDITIONS

Application of Australian Capital Territory additions

This Appendix contains additional provisions for application in the Australian Capital Territory as follows:

ACT 1—* * * * *

This clause has been deliberately left blank.

HEALTH AND AMENITY

ACT 2—HAZARDOUS MATERIALS

ACT 2.1 PERFORMANCE PROVISIONS

Objective

The *Objective* is to safeguard people from illness resulting from exposure to asbestos building materials during removal and disposal.

Functional Statement

Asbestos building material shall be removed and disposed of in a safe manner.

Performance Requirement

When asbestos-based material in any form or in any mixture thereof, or any material containing loose asbestos including asbestos fluff insulation, asbestos sheeting, lagging, fire protection and the like is removed, it must be handled and disposed of safely.

ACT 2.2 ACCEPTABLE CONSTRUCTION PRACTICE

The requirements of **ACT P2** are satisfied when asbestos-based materials are handled and disposed of in accordance with the Worksafe Australia Code of Practice and Guidance Notes.

ACT 3—CONTROL OF LITTER ON BUILDING SITES
--

ACT 3.1 PERFORMANCE PROVISIONS

Objective

The *Objective* of this provision is to prevent wind blown litter from building sites fouling roads and public land.

Functional Statement

Building litter must be prevented from spreading around the site and beyond the site boundary.

Performance Requirement

Sufficient containers must be provided on building sites to store building waste that is likely to become windblown.

ACT 3.2 ACCEPTABLE CONSTRUCTION PRACTICE

The requirements of **ACT P3** are satisfied by:

On site building waste that is stored in suitable size plastic or metal bins and removed from the site at regular intervals.

Note:

Building Waste includes: plastic containers and plastic and paper wrappings or any waste that can be carried by wind.

ACT 4—WASTE MANAGEMENT

ACT 4.1 PERFORMANCE PROVISIONS

Objective

The *Objective* of this provision is to safeguard people from injury caused by infection or contamination from solid waste.

Functional Statement

Buildings must be provided with space and facilities for the collection, and safe hygienic holding prior to disposal of solid waste arising from the intended use of the building.

Performance Requirement

Where provision is made within buildings for the collection and temporary holding of solid waste, the design shall accommodate screening, volume of waste, disposal, logistics and access.

ACT 4.2 ACCEPTABLE CONSTRUCTION PRACTICE

The requirements of **ACT P4** are satisfied by garbage facilities that are designed and constructed in accordance with the Development Control Code for Best Practice Waste Management in the ACT.

ACT 5—ENERGY EFFICIENCY

Limitation:

ACT 5 applies to Class 1 buildings only.

ACT 5.1 PERFORMANCE PROVISIONS

Objective

The *Objective* of this Part is to facilitate efficient use of energy in a building.

Functional Statement

A building is to be designed to achieve efficient use of energy for internal heating and cooling.

Performance Requirement

A building must have an adequate level of thermal performance to ensure efficient use of energy for internal heating and cooling.

ACT 5.2 ACCEPTABLE CONSTRUCTION PRACTICE

ACT 5.2.1 Energy efficiency

The requirements of **ACT P5** are satisfied by—

- (a) A building that achieves an ACT House Energy Rating of 4 Stars as assessed by an accredited ACT House Energy Assessor; or
- (b) by any other assessment method, satisfying P5; and
- (c) in the case of an addition to an existing building, by—
 - (i) complying with **P5** or (a); or
 - (ii) complying with **ACT Table 1** and having—
 - (A) a concrete floor; or
 - (B) a timber floor with an R rating of 1 including carpets.

ACT Table 1 MINIMUM INSULATION MATERIAL

Roofs

- (a) R3 insulation material in the ceiling space; or
- (b) R2 insulation material in exposed raked ceiling (concession).

Walls

R1.5 insulation material in the external wall space.

ACT 5.2.2 Exemptions

The requirements of this Part do not apply to the following types of construction:

- (a) Cavity brick, earthwall construction, ashlar stone or other masonry walls which have a thickness (excluding any cavity) of not less than 180 mm do not require wall insulation.
- (b) Class 10 structures forming part of a Class 1 building.

- (c) Moveable dwellings and mobile homes where their form of prefabricated construction does not readily permit achievement of optimal insulation requirements.

ACT 5.2.3 Fire resistance of insulation materials

When tested in accordance with AS/NZS 1530.3 a thermal insulation material must have a *Spread-of-Flame Index* of 0 and a *Smoke-Developed Index* not greater than 4.

ACT 6—SWIMMING POOL CONSTRUCTION

Application:

This requirement is to be applied in conjunction with [Part 3.9.3](#).

ACT 6.1 Swimming pool construction

Indoor or outdoor permanent bathing, wading and *swimming pools* must—

- (a) where the capacity of the pool exceeds 10 m³—
- (i) be of the recirculation type in which the water circulation is maintained through the pool by pumps, the water drawn from the pool being clarified and disinfected before being returned to the pool; and
 - (ii) have an outlet sump with antivortex cover or grating and have a skimming weir or overflow gutter or channel at high water level; and
 - (iii) have means of egress provided in the form of ladders, steps in the floor of the pool or a ramp; and
- (b) be capable of being completely emptied and any discharge or overflow and pool backwash filter must be connected to the sewer drainage system; and
- (c) be watertight with smooth surfaces of non-absorbent, non-slip material, light in colour and with rounded corners to facilitate cleaning; and
- (d) have surrounding concourses graded away from the pool.

OTHER LEGISLATION AFFECTING BUILDINGS

In addition to the requirements of the ACT Building Act 1972 and the ACT Building Code, administered by ACT Building Electrical and Plumbing Control, (BEPCON) builders and designers should be aware of other legislation which contains building requirements.

The following is a list of some of the other relevant legislation:

1. Health Legislation

Public Health Regulations 2000 (Dept of Health, Housing and Community Care)

2. Environmental Control and Emission Standards

Environment Protection Act 1997 (Department of Urban Services (DUS))

3. Occupational Health and Safety

ACT Demolition Code of Practice (ACT WorkCover)

Occupational Health and Safety Act 1989 (ACT WorkCover)

4. Public Housing

Housing Assistance Act 1987 (ACT Housing, ACT Health Trust)

5. Scaffolding and Temporary Works

Scaffolding and Lifts Regulations 1950 (ACT WorkCover)

6. Urban Design Standards, Land Title and Tenure

ACT (Planning and Land Management) Act 1988 (National Capital Authority) (NCA)

City Area Leases Act 1936 (For leases before the Land Act commenced) (DUS)

Common Boundaries Act 1981 (DUS)

Land (Planning and Environment) Act 1991 (DUS)

Leases (Special Purposes) Act 1925 (For leases before the Land Act commenced) (DUS)

National Land Ordinance 1989 (NCPA)

Unit Titles Act 1970 (DUS)

7. Utility Services and Urban Infrastructure

Electricity Safety Act 1971 (BEPCON, DUS)

Gas Supply Act 1998 (ActewAGL, ACT WorkCover)

Protection of Lands Act 1937 (DUS)

Roads and Public Places Act 1937 (DUS)

Utilities Act 2000 (Department of Treasury, DUS)

Water and Sewerage Act 2000 (DUS)

CONTENTS

NEW SOUTH WALES

New South Wales Additions

- NSW 1.1 Performance Provisions
- NSW 1.2 Acceptable Construction Practice
- NSW2.1 Definitions
- NSW 2.2 Performance Provisions
- NSW 2.3 Acceptable Construction

NEW SOUTH WALES ADDITIONS

Application of New South Wales additions

This Appendix contains additional provisions for application in New South Wales as follows:

NSW 1—WATER RECIRCULATION AND FILTRATION SYSTEMS

NSW 1.1 PERFORMANCE PROVISIONS

Objective

The *Objective* is to safeguard young children from drowning or injury in a *swimming pool*.

Functional Statement

A *swimming pool* must be provided with means to minimise the risk of entrapment or injury of young children using the pool.

Performance Requirement

The water recirculation and filtration system in a *swimming pool* must incorporate safety measures to avoid entrapment of or injury to a young child.

NSW 1.2 ACCEPTABLE CONSTRUCTION PRACTICE

NSW 1.2.1 Application

For a *swimming pool* with a depth of water more than 300 mm, compliance with the provisions of **NSW 1.2** for water recirculation and filtration systems satisfies *Performance Requirement NSW 1.1*.

NSW 1.2.2 Water recirculation and filtration system

A *swimming pool* water recirculation and filtration system must comply with AS 1926.3.

NSW 2—ENERGY EFFICIENCY

NSW 2.1 DEFINITIONS

Definitions in BCA Volume 2 Part 1 apply in this NSW Addition, except that any definition that makes reference to "for the purposes of Part 2.6" or "for the purposes of Part 3.12" are to be read as referring to "for the purposes of NSW 2", where relevant.

The following definitions are used in this Part:

Conditioned space means a space within a building—

- (a) that is heated or cooled by the building's *domestic services*; but

- (b) excludes a heater with a capacity of not more than 1.2 kW installed in a *non-habitable room*.

Piping means an assembly of pipes, with or without valves or other fittings, connected together for the conveyance of liquids.

Reflective insulation means a building membrane with a reflective surface such as a reflective foil laminate, reflective barrier, foil batt or the like capable of reducing radiant heat flow.

R-Value means the thermal resistance ($m^2.K/W$) of a component calculated by dividing its thickness by its thermal conductivity.

Total R-Value means the sum of the *R-Values* of the individual component layers in a composite element including the air space and associated surface resistances.

Total U-Value means the thermal transmittance ($W/m^2.K$) of the composite element including the air space and associated surface transmittance.

Ventilation opening means an opening in the *external wall*, floor or roof of a building designed to allow air movement into or out of the building by natural means including a permanent opening, an openable part of a *window*, a door or other device which can be held open.

NSW 2.2 PERFORMANCE PROVISIONS

Objective

The *Objective* is to reduce greenhouse gas emissions by efficiently using energy.

Functional Statement

A building, including its *domestic services*, is to be capable of efficiently using energy.

Performance Requirement

NSW P2.1 Building Fabric Thermal Insulation

Insulation in a building must be installed in a manner and have characteristics, which facilitate the efficient use of energy for artificial heating and cooling.

Application:

- (a) NSW P2.1 only applies to thermal insulation in a Class 1 or 10 building where a development consent, complying development certificate, or an environmental planning instrument specifies that the insulation is to be provided as part of the development.
- (b) In (a), development consent, complying development certificate, environmental planning instrument and development, have the meaning given to these terms by the Environmental Planning and Assessment Act 1979.

NSW P2.2 Building sealing

A building must have, to the degree necessary, a level of building sealing against air leakage to facilitate the efficient use of energy for artificial heating and cooling appropriate to—

- (a) the function and use of the building; and
- (b) the internal environment; and
- (c) the geographic location of the building.

Limitation:

NSW P2.2 does not apply to—

- (a) existing buildings being relocated; or
- (b) Class 10a buildings—
 - (i) without a *conditioned space*; or
 - (ii) used for the accommodation of vehicles; or
- (c) parts of buildings that cannot be fully enclosed; or
- (d) a building *ventilation opening* that is necessary for the safe operation of a gas appliance.

Explanatory information:

1. NSW P2.2 does not apply to those parts of buildings with permanent openings that are not capable of being fully enclosed, ie, balconies, shade rooms, rooms with fixed louvres, mesh or other material that allows air flow. Adjustable louvres are considered to provide full enclosure to the opening they accommodate.
Such rooms are unlikely to be conditioned given the high air flow rates; therefore application of the Performance Requirement to these parts of buildings would not result in reduction in energy use.
2. Appropriate ventilation for gas appliances can be obtained from relevant legislation, referenced standards and product installation manuals. For example, the Gas Supply (General) Regulation, 1997 references AS 560/AG 601 Gas installations.

NSW P2.3 Building services

A building's *domestic services*, including any associated distribution system and components must have features that, to the degree necessary, facilitate the efficient use of energy appropriate to—

- (a) the *domestic service* and its usage; and
- (b) the geographic location of the building; and
- (c) the location of the *domestic service*; and
- (d) the energy source.

Limitation:

NSW P2.3 does not apply to existing services associated with an existing building being relocated.

NSW 2.3 ACCEPTABLE CONSTRUCTION

NSW 2.3.1 BUILDING FABRIC THERMAL INSULATION

Appropriate *Performance Requirements*

Where an alternative approach to building fabric thermal insulation is proposed as an *Alternative Solution* to that described in NSW 2.3.1, that proposal must comply with—

- (a) *Performance Requirement* **NSW P2.1**; and

- (b) the relevant *Performance Requirements* determined in accordance with 1.0.10.

Acceptable construction practice

NSW 2.3.1.0 Compliance with **NSW 2.3.1.1** to **NSW 2.3.1.4** satisfies **NSW P2.1** for insulation.

NSW 2.3.1.1 Application

- (a) NSW 2.3.1 only applies to thermal insulation in a Class 1 or 10 building where a development consent, complying development certificate, or an environmental planning instrument specifies that the insulation is to be provided as part of the development.
- (b) In (a), development consent, complying development certificate, environmental planning instrument and development, have the meaning given to these terms by the Environmental Planning and Assessment Act 1979.

NSW 2.3.1.2 Insulation

All insulation must—

- (a) comply with—
 - (i) AS/NZS 4859.1; or
 - (ii) AS 2464.3 for loose fill insulation; or
 - (iii) AS 2464.5 where a heat flow meter is used to determine the thermal transmission properties; or
 - (iv) AS 2464.6 where a guarded hot plate is used to determine the thermal transmission properties; and
- (b) be installed so that it forms a continuous barrier with ceilings, walls, bulkheads, floors or the like that inherently contribute to the thermal barrier.

Explanatory information:

Typical arrangements for continuous thermal barriers.

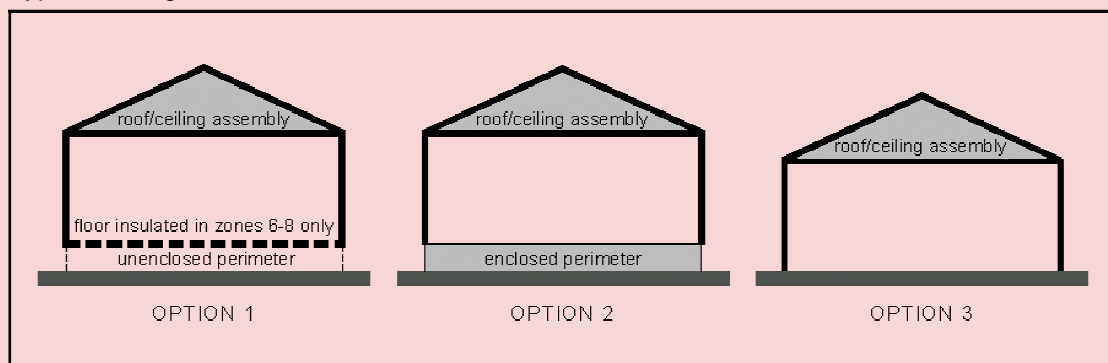

NSW 2.3.1.3 Bulk insulation

- (a) Bulk insulation must be installed so that —
 - (i) it maintains its position and thickness; and

- (ii) it abuts other bulk insulation or building members to ensure there are no voids in the *envelope*, other than around a *domestic service* or fitting where insulation may affect their safe or effective operation; and
 - (iii) where there is no bulk insulation or *reflective insulation* in a wall, ceiling insulation overlaps the wall member by not less than 50 mm.
- (b) (a)(i) does not apply to foil backed blanket bulk insulation under metal deck roofing.

NSW 2.3.1.4 Reflective insulation

Reflective insulation must be installed with—

- (a) an airspace, specified in accordance with AS/NZS 4859.1, AS 2464.3, AS 2464.5 or AS 2464.6 as determined under 2.3.1.2(a), between a reflective side of the *reflective insulation* and the building lining or cladding; and
- (b) the *reflective insulation* closely fitted against any door or *window* opening or any other penetration, other than around a *domestic service* or fitting where the *reflective insulation* may affect their safe or effective operation; and
- (c) the *reflective insulation* adequately supported by framing members; and
- (d) each adjoining sheet of roll membrane being—
 - (i) overlapped not less than 50 mm; or
 - (ii) taped together.

Explanatory information:

1. The *R-Value* of *reflective insulation* is affected by the airspace between a reflective side of the *reflective insulation* and the building lining or cladding. The actual *R-Value* added by an *reflective insulation* should be determined for each product in accordance with AS/NZS 4859.1, AS 2464.3, AS 2464.5 or AS 2464.6 as appropriate, which takes into consideration factors such as the number of adjacent airspaces, dimensions of the adjacent airspace, whether the space is ventilated and the presence of an anti-glare coating. When an *reflective insulation* has an anti-glare coating on one side, the emittance value of that side will be greater than the value of the uncoated side.
2. The width for any reflective air spaces adjacent to *reflective insulation* will not override other Housing Provisions such as minimum cavity requirements for masonry waterproofing.
3. Care should be taken when installing insulation to ensure that it does not interfere with the safety or performance of *domestic services* and fittings such as heating flues, recessed light fittings, gas appliances and general plumbing and electrical components. This includes providing appropriate clearance as detailed in relevant legislation and referenced standards such as for electrical, gas and fuel installations.
4. Artificial cooling of buildings in some climates can cause condensation to form inside the layers of the building *envelope*. Such condensation can cause significant structural or cosmetic damage to the *envelope* before it is detected. Associated mould growth may also create health risks to the occupants. Effective control of condensation is a complex issue. In some locations a fully sealed vapour barrier may need to be installed on the more humid, or generally warmer, side of the insulation. Consideration of condensation in some climate zones should be given to interaction with adjoining building materials.
5. The *R-value* of bulk insulation is lowered if it is compressed into a space. The allocated space for bulk insulation must allow the insulation to be installed so that

it maintains its thickness. This is particularly relevant to wall framing and cathedral ceilings where standard member sizes can only accommodate a certain thickness of bulk insulation. If thicker insulation is to be used, the framing member sizes must be increased to accommodate or a thinner insulation material used of an equivalent *R-value*.

6. Foil backed blanket is exempted from these requirements as it is usually laid over roofing members and compressed when the metal deck roofing is fixed to the roofing members to reduce noise and condensation. Where a greater level of insulation is required beyond that provided by foil backed blanket, a higher level of thermal performance can be achieved by a thin layer of foil backed blanket under roofing and a layer of bulk insulation between roofing members or above ceilings to provide the overall *R-value*.
7. AS/NZS 4859 Part 1 supersedes AS 2464 Parts 3, 5 and 6. To provide industry time to adjust to AS/NZS 4859 Part 1, NSW 2.3.1 allows the use of either standard. It is anticipated in May 2005, AS 2464 Parts 3, 5 and 6 will be withdrawn from BCA 2005.

NSW 2.3.2 BUILDING SEALING

Appropriate Performance Requirements

Where an alternative approach to building fabric thermal insulation is proposed as an *Alternative Solution* to that described in NSW 2.3.2, that proposal must comply with—

- (a) *Performance Requirement* **NSW P2.2**; and
- (b) the relevant *Performance Requirements* determined in accordance with **1.0.10**.

Acceptable construction practice

NSW 2.3.2.0 Compliance with **NSW 2.3.2.1** to **NSW 2.3.2.6** satisfies **NSW P2.2** for building sealing.

NSW 2.3.2.1 Application

NSW 2.3.2 is not applicable to—

- (a) existing buildings being relocated; or
- (b) Class 10a buildings—
 - (i) without a *conditioned space*; or
 - (ii) used for the accommodation of vehicles; or
- (c) parts of buildings that cannot be fully enclosed; or
- (d) a building *ventilation opening* that is necessary for the safe operation of a gas appliance.

NSW 2.3.2.2 Chimneys and flues

A chimney or flue of an open solid-fuel burning appliance must be provided with a damper or flap that can be closed to seal the chimney or flue.

Explanatory information:

1. The requirements of this Part are to be read in conjunction with the fire safety requirements in **Part 3.7.3**.

2. A solid-fuel burning device is a heater that burns material such as timber, coal and the like. This clause does not apply to gas and liquid fuel burning devices.

NSW 2.3.2.3 Roof lights

- (a) A *roof light* must be sealed, or capable of being sealed, in accordance with (b) to minimise air leakage when serving—
- (i) a *conditioned space*; or
 - (ii) a *habitable room* in *climate zones* 4, 6, 7 and 8.
- (b) A *roof light* required by (a) to be sealed or capable of being sealed must be constructed with—
- (i) an imperforate ceiling diffuser or the like installed at the ceiling or internal lining level; or
 - (ii) a shutter system readily operated either manually, mechanically or electronically by the building occupant; or
 - (iii) if it is a *roof window*, a foam or rubber compressible strip, fibrous seal or the like.

NSW 2.3.2.4 External windows and doors

- (a) A seal to restrict air infiltration must be fitted to each edge of an external door, openable *window* and other such opening—
- (i) when serving a conditioned space; or
 - (ii) in *climate zones* 4, 6, 7 and 8 when serving a habitable room.
- (b) An external door, *window* or other such opening is exempt from (a) if it is—
- (i) a *window* complying with AS 2047; or
 - (ii) a glazed assembly exempt from compliance with AS 2047 under **3.6.0**.
- (c) A seal *required* by (a) may be a foam or rubber compressible strip, fibrous seal or the like.

Explanatory information:

Requirements for the sealing of louvres are under consideration for future inclusion in the Housing Provisions. The outcome will depend on the availability of complying products.

NSW 2.3.2.5 Exhaust fans

An exhaust fan must be fitted with a sealing device such as a self-closing damper, filter or the like when serving—

- (a) a *conditioned space*; or
- (b) a *habitable room* in *climate zones* 4, 6, 7 and 8.

NSW 2.3.2.6 Construction of roofs, walls and floors

- (a) Roofs, *external walls*, external floors and any opening such as a *window*, door or the like in the external *fabric* must be constructed to minimise air leakage in accordance with (b) when forming part of the external *fabric* of—
- (i) a *conditioned space*; or
 - (ii) a *habitable room* in *climate zones* 4, 6, 7 and 8.

- (b) Construction *required* by (a) must be—
 - (i) enclosed by internal lining systems that are close fitting at ceiling, wall and floor junctions; or
 - (ii) sealed by caulking, skirting, architraves, cornices or the like.

NSW 2.3.3 SERVICES

Appropriate Performance Requirements:

Where an alternative approach to building fabric thermal insulation is proposed as an *Alternative Solution* to that described in NSW 2.3.3, that proposal must comply with—

- (a) *Performance Requirement* **NSW P2.3**; and
- (b) the relevant *Performance Requirements* determined in accordance with **1.0.10**.

Acceptable construction practice

NSW 2.3.3.0 Compliance with **NSW 2.3.3.1** to **NSW 2.3.3.5** satisfies **NSW P2.3** for building services.

NSW 2.3.3.1 Application

NSW 2.3.3 is not applicable to existing services associated with an existing building being relocated.

NSW 2.3.3.2 Hot water supply system

A hot water supply system must be designed and installed in accordance with Section 8 of AS/NZS 3500.4 or clause 3.38 of AS/NZS 3500.5.

NSW 2.3.3.3 Insulation of services

Thermal insulation for central heating water *pipng* and heating and cooling ductwork *required* by **NSW 2.3.3.4** and **NSW 2.3.3.5**, must be—

- (a) protected against the effects of weather and sunlight; and
- (b) able to withstand the temperatures within the *pipng* or ductwork.

Explanatory information:

The documents referred to in 2.3.3.2 are for use with hot water systems that provide hot water for general domestic use in areas such as bathrooms, kitchens, laundries and the like.

The central heating water *pipng* provisions apply to hot water systems designed to heat the building.

NSW 2.3.3.4 Central heating water piping

Central heating water *pipng* that is not within a *conditioned space* must be thermally insulated to achieve the minimum *Total R-Value* in accordance with Table 2.3.4.5.

Table 2.3.4.5 CENTRAL HEATING WATER PIPING—MINIMUM THERMAL INSULATION

<i>Piping to be insulated</i>		<i>Minimum Total R-Values for each climate zone</i>		
		2 and 5	4, 6 and 7	8
1.	Internal piping			
	(a) All flow and return <i>piping</i> that is— (i) within an unventilated wall space; or (ii) within an internal floor between storeys; or (iii) between ceiling insulation and a ceiling.	0.2	0.2	0.2
	(b) All hot water <i>piping</i> encased within a concrete floor slab (except that which is part of a floor heating system).			
2.	Piping located within a ventilated wall space, an enclosed building sub-floor or a roof space			
	(a) All flow and return <i>piping</i> .	0.3	0.45	0.6
	(b) Cold water supply <i>piping</i> —within 500 mm of the connection to the central water heating system.			
	(c) Relief valve <i>piping</i> —within 500 mm of the connection to the central water heating system.			
3.	Piping located outside the building or in an unenclosed building sub-floor or roof space			
	(a) All flow and return <i>piping</i> .	0.3	0.6	0.6
	(b) Cold water supply <i>piping</i> —within 500 mm of the connection to the central water heating system.			
	(c) Relief valve <i>piping</i> — within 500 mm of the connection to the central water heating system.			

Explanatory information:

- The insulation levels in the following table are typical examples of materials that can be used to insulate central heating water *piping*. Other methods are available for meeting the *Total R-Values required* by Table 2.3.4.5.
- Piping* within a timber member, such as that passing through a wall stud, is considered to have sufficient insulation for the purposes of Table 2.3.4.5.

Insulation	Total R-Value
9 mm of closed cell polymer	0.2
13 mm of closed cell polymer	0.3
19 mm of closed cell polymer	0.45
25 mm of closed cell polymer	0.6

NSW 2.3.3.5 Heating and cooling ductwork

- (a) Heating and cooling ductwork and fittings must—
 - (i) be thermally insulated to achieve the minimum *Total R-Value* in accordance with **Table 2.3.3.5** for the relevant *climate zone*; and
 - (ii) use thermal insulation material in accordance with—
 - (A) AS/NZS 4859.1; or
 - (B) AS 2464.5 for determining thermal transmission properties by means of a heat flow meter; or
 - (C) AS 2464.6 for determining thermal transmission properties by means of a guarded hot plate; and
 - (iii) be sealed against air loss—
 - (A) by closing all openings in the surface, joints and seams of ductwork with adhesives, mastics, sealants or gaskets in accordance with AS 4254 for a Class C seal; or
 - (B) for flexible ductwork, with a sealant and draw band encased with adhesive tape.

Explanatory information:

AS/NZS 4859 Part 1 supersedes AS 2464 Parts 3, 5 and 6. To provide industry time to adjust to AS/NZS 4859 Part 1, NSW subclause 2.3.3.5(a)(ii) allows the use of either standard. It is anticipated in May 2005, AS 2464 Parts 3, 5 and 6 will be withdrawn from BCA 2005

- (b) Duct insulation located under a suspended floor, in an attached Class 10a building and in a roof space must —
 - (i) be protected by an outer sleeve of protective sheeting to prevent the insulation becoming damp; and
 - (ii) have the outer protective sleeve sealed with adhesive tape not less than 48 mm wide creating an airtight and waterproof seal.
- (c) The requirements of (a) do not apply to heating and cooling ductwork and fittings located within the insulated building *envelope* including a service riser within the *conditioned space*, internal floors between storeys and the like.

Explanatory information:

1. Ductwork within a fully insulated building may still benefit from insulation particularly when the system is only operating for short periods.
2. In some *climate zones* condensation may create problems with uninsulated ductwork and insulation should still be considered.

Table 2.3.3.5 HEATING AND COOLING DUCTWORK—MINIMUM THERMAL INSULATION

Location and element		Minimum <i>Total R-Value</i> for ductwork for each <i>climate zone</i>			
		Evaporative cooling	Heating system or Refrigerated cooling system		
			All <i>climate zones</i>	<i>Climate zones</i>	
				4, 6 and 7	2 and 5
1. Under enclosed suspended floors	Ductwork	0.6	1.0	1.0	1.5
2. Roof spaces	Metal heating fittings	0.1	0.1	0.1	0.1
3. External to the building	Ductwork	0.6	1.5	1.0	1.5
4. Under open suspended floors					

Explanatory information:

1. Insulation for refrigerated cooling ductwork should have a vapour barrier to prevent possible damage by condensation.
2. Any flexible ductwork used for the transfer of products, initiating from a heat source that contains a flame, must also have the fire hazard properties required by 3.7.1.9.
3. The insulation levels in the following table are typical examples of materials that can be used to insulate ductwork and fittings. Other methods are available for meeting the Total R-Values required by Table 2.3.3.5.
4. The addition of foil backing to the insulation and plastic protective sheeting is not considered to change the Total R-Values in the following table unless supported by appropriate documentary evidence.

Insulation	Total R-Value
4 mm closed cell polymer	R0.1
8 mm polyurethane spray	R0.1
40 mm polyester fibre insulation (250 g/m)	R0.6
70 mm polyester fibre insulation (450 g/m)	R1.0
90 mm polyester fibre insulation (800 g/m)	R1.5
25 mm mineral wool or fibreglass insulation (480 g/m)	R0.6
38 mm mineral wool or fibreglass insulation (560 g/m)	R1.0
x`50 mm mineral wool or fibreglass insulation (840 g/m)	R1.5

SUPERSEDED
STATE AND TERRITORY ADDITIONS

CONTENTS

NORTHERN TERRITORY - No additional provisions

NORTHERN TERRITORY - No additional provisions

SUPERSEDED
STATE AND TERRITORY ADDITIONS

NORTHERN TERRITORY ADDITIONS

The Northern Territory has no additions to the Housing Provisions.

CONTENTS

QUEENSLAND

Health and Amenity

QLD 1 * * * * *

QLD 2 Flashing of Narrow Spaces and Vermin Control

QUEENSLAND ADDITIONS

Application of Queensland variations

This Appendix contains additional provisions for application in Queensland as follows:

HEALTH AND AMENITY

QLD 1—* * * * *

This clause has been deliberately left blank.

QLD 2—FLASHING OF NARROW SPACES AND VERMIN CONTROL

QLD 2.1 PERFORMANCE PROVISIONS

Objective

The *Objective* is to safeguard people from injury and illness resulting from the creation of hazardous spaces between buildings.

Functional Statement

The space between buildings must not allow hazardous conditions to arise due to vermin and weather.

Performance Requirement

Spaces between buildings on adjoining sites which are narrower than 600 mm must be sealed off and flashed over to prevent the entrance of weather and vermin.

QLD 2.2 ACCEPTABLE CONSTRUCTION PRACTICE

Qld 2.2.1 Control of vermin

Buildings must be constructed to prevent the entry of vermin in accordance with Part 17 (Vermin Control) of the Health Regulation 1996.

CONTENTS

SOUTH AUSTRALIA

Acceptable Construction Manual

SA 1 Application

Health and Amenity

SA 3 Wet Areas

Safe movement and access

SA 4 Swimming Pool Safety

SA 5 Access for People with Disabilities

SA 6 Access for Inspection and Maintenance

SOUTH AUSTRALIA ADDITIONS

Application of South Australian variations

This Appendix contains additional provisions for application in South Australia as follows:

SA ACCEPTABLE CONSTRUCTION MANUAL

SA 1 APPLICATION

Compliance with the *Deemed-to-Satisfy Provisions* of the South Australian Housing Code for Class 1a and Class 10a buildings satisfies the *Performance Requirements* in Section 2 as modified by any variations and additions for South Australia.

HEALTH AND AMENITY

SA 3 WET AREAS

SA 3.1 PERFORMANCE PROVISIONS

Objective

As per [Section 2 Objectives](#) for wet areas.

Functional Statement

As per [Section 2 Functional Statement](#) for wet areas.

Performance Requirement

Floors in bathrooms, or rooms containing a shower or a sanitary fixture, must be installed in a manner that will prevent accumulation of water on the surface which could create unhealthy or hazardous conditions.

SA 3.2 ACCEPTABLE CONSTRUCTION PRACTICE

SA 3.2.1 Application

Performance Requirements [P2.4.1](#) and [SA3.1](#) are satisfied for wet areas in Class 1 and 10 buildings if they are waterproofed in accordance with AS 3740 and the additional requirements of Minister's Specification SA F1.7.

SAFE MOVEMENT AND ACCESS

SA 4 SWIMMING POOL SAFETY

Limitation:

SA 4 only applies to a *swimming pool* associated with a Class 1 building with a depth of water more than 300 mm.

SA 4.1 PERFORMANCE PROVISIONS

Objective

As per Section 2 *Objective* **O2.5**.

Functional Statement

A *swimming pool* must not allow a young child to be entrapped or injured due to suction by pump intakes.

Performance Requirement

Pump intakes to *swimming pools* must have such dimensions and safety protection measures so as to prevent injury to a young child due to entrapment by suction.

SA 4.2 ACCEPTABLE CONSTRUCTION PRACTICE

SA 4.2.1 Application

Compliance with the acceptable construction practice provisions of **SA 4.2.2** and **SA 4.2.3** for swimming pool pump intakes satisfies *Performance Requirement* **SA 4.1**.

SA 4.2.2 Pump Intakes

A swimming pool water recirculation and filtration system must comply with AS 1926.3.

SA 4.2.3 Warning Notice

- (a) Wherever a manual shut-off valve is fitted to a secondary outlet from a swimming pool, a permanent, durable label must be fixed to the valve.
- (b) A label referred to in (a) must be in capital letters not less than 2.5 mm high in a colour contrasting with the background, and in printing that is resistant to ultra-violet light, water and pool chemicals, and state:

WARNING

**RE-OPEN THIS VALVE IMMEDIATELY AFTER USING A VACUUM CLEANER
THE POOL MUST NOT BE USED WHILE A VACUUM CLEANER IS IN USE**

SA 5 ACCESS FOR PEOPLE WITH DISABILITIES

Limitation:

SA 5 applies to Class 1 buildings in developments of 20 or more dwellings.

SA 5.1 PERFORMANCE PROVISIONS

Objective

Provide, as far as is reasonable, people with safe, equitable and dignified access to a degree necessary to—

- (a) buildings; and
- (b) the services and facilities within.

Functional Statement

A building to a degree necessary is, as far as is reasonable, to provide safe, equitable and dignified access for people to the services and facilities within.

Performance Requirement

Buildings and immediate surrounds must have appropriate features to a degree necessary to enable people with disabilities to safely and equitably—

- (a) negotiate the route from the road boundary to and within the building using a wheelchair; and
- (b) have access to spaces within the building, including facilities *required* under [P2.4.3](#).

SA 5.2 ACCEPTABLE CONSTRUCTION PRACTICE

SA 5.2.1 Application

Compliance with the acceptable construction practice provisions of [Part SA 5.2](#) for access for people with disabilities satisfies *Performance Requirement SA 5.1*.

[SA Part 5.2](#) applies to certain Class 1 buildings where access is *required* under [Clause SA 5.2.2](#).

SA 5.2.2 Access to buildings

In developments consisting of 20 or more dwellings, access must be provided to and within one dwelling or 5% of the total number of dwellings, whichever is the greater.

SA 5.2.3 Parts of buildings to be accessible

- (a) Access for people with disabilities must be provided from the entrance doorway to areas normally used by the occupants. A path of travel providing *required* access must not include a stairway or other impediment which would prevent a person in a wheelchair using it.
- (b) Access, finishes and fittings must comply with the provisions of AS 1428.1.
- (c) In every Class 1 building to which access for people with disabilities is *required*, one closet pan and washbasin and one shower must be provided for use by people with disabilities.

SA 6 ACCESS FOR INSPECTION AND MAINTENANCE

SA 6.1 PERFORMANCE PROVISIONS

Objective

The *Objective* is to safeguard people from injury and illness resulting from the creation of hazardous spaces between buildings.

Functional Statement

The space between buildings must not allow hazardous conditions to arise due to accumulation of rubbish that cannot be readily removed.

Performance Requirement

The space between buildings must be sufficient to allow access for inspection and maintenance to avoid hazardous conditions arising due to accumulation of rubbish that could—

- (a) bridge termite barriers; or
- (b) harbour vermin; or
- (c) create a fire hazard.

SA 6.2 ACCEPTABLE CONSTRUCTION PRACTICE

SA 6.2.1 Application

Compliance with the acceptable construction provision of **SA 6.2** for acceptable separation between buildings for Class 1 and 10 buildings satisfies *Performance Requirement SA 6.1*.

SA 6.2.2 Minimum separation between buildings

Unless the space between external columns is not infilled, every part of an *external wall* of a building must be not less than 600 mm from—

- (a) any boundary of the allotment, unless that wall is on or abutting that boundary; or
- (b) the *external wall* of any other building on the same allotment, unless the two buildings are abutting.

CONTENTS

TASMANIA

Fire safety

TAS 1 Non-Combustible Roof Coverings

Safe movement and access

TAS 2 Swimming Pool Water Reticulation and Filtration

TASMANIA ADDITIONS

Application of Tasmanian variations

This Appendix contains additional provisions for application in Tasmania as follows:

FIRE SAFETY

Limitation:

Tas 1 does not apply to—

1. roof coverings or canopies of PVC, Acrylic, Polycarbonate and GRP sheeting over a balcony, verandah, carport, covered way, swimming pool, barbecue area, or similar open structure attached to a Class 1 building; or
2. Class 1 buildings on land zoned Rural (except Rural Residential) in the Municipality's or City's sealed Planning Scheme, Effective Interim Order, or Special Planning Order if situated at a distance of not less than 30 m from a wooden building or the allotment boundary or not less than 15 m from other buildings; and
3. where, in accordance with 2., a roof is covered with wood shingles or shakes, the shingles or shakes are underlaid with a material having a *Flammability index* not greater than 2.

TAS 1—NON-COMBUSTIBLE ROOF COVERINGS

TAS 1.1 PERFORMANCE PROVISIONS

Objective

The fire safety *Objective* is to prevent the spread of fire from air-borne embers.

Functional Statement

Protect Class 1 buildings from air-borne embers.

Performance Requirement

A Class 1 building must be protected from the spread of fire from air-borne embers from other property by the provision of a *non-combustible* roof covering.

TAS 1.2 ACCEPTABLE CONSTRUCTION PRACTICE

Tas 1.2.1 Non-combustible roofing

A roof covered with any of the following materials satisfies the *Performance Requirements* of [Tas 1.1](#).

- (a) Metal sheeting or tiles.
- (b) Slates.
- (c) Terracotta or cement roofing tiles.

- (d) Fibre cement sheeting or shingles.
- (e) Asphalt shingles except on buildings with rise in storeys exceeding 2.
- (f) Built-up roofing covered with *non-combustible* material.
- (g) Concrete, granolithic, terrazzo, cement mortar, or other similar *non-combustible* materials.

HEALTH AND AMENITY

TAS 2 SWIMMING POOL WATER RETICULATION AND FILTRATION

Limitation:

Tas 2 does not apply to a *swimming pool* associated with a Class 1 building if the depth of water is less than 300 mm and the volume of the pool does not exceed 15 m³.

TAS 2.1 PERFORMANCE PROVISIONS

Objective

The *objective* is to safeguard people from illness or injury arising from the use of a *swimming pool*.

Functional Statement

Swimming pools must provide for the health and safety of swimmers and others.

Performance Requirement

Swimming pools must be provided with an adequate water recirculation, disinfection and filtration system which is suitable and safe to use.

TAS 2.2 ACCEPTABLE CONSTRUCTION PRACTICE

Tas 2.2.1 Application

Compliance with the provisions of Tas 2.2 for a *swimming pool* associated with a Class 1 building with a depth of water more than 300 mm and volume exceeding 15 m³ satisfies *Performance Requirement Tas 2.1*.

Tas 2.2.2 Water recirculation and filtration system

A water recirculation, disinfection and filtration system in a *swimming pool* must provide for—

- (a) the inlet and outlet openings for the purpose of water recirculation to be so located that water movement is continuous from inlet to outlet; and
- (b) the inlet and outlet openings, and skimmer boxes where provided, to comply with AS 1926.3; and
- (c) the recirculation of water to be so designed that the pool contents are recirculated not less than once-
 - (i) in 6 hours for an outdoor *swimming pool*; or
 - (ii) in 4 hours for an indoor *swimming pool*; and
- (d) the water filtration rates to not exceed 12 250 L/m² of sand filter bed per hour, or an equivalent rate in other filter media.

CONTENTS

VICTORIA

Health and amenity

VIC 1 Energy Efficiency

Special requirements for certain buildings and components

VICTORIA ADDITIONS

Application of Victorian variations

This Appendix contains additional provisions for application in Victoria as follows:

HEALTH AND AMENITY

VIC 1—ENERGY EFFICIENCY

Limitation:

VIC 1 applies to Class 1 buildings only.

VIC 1.1 * * * * *

This clause has deliberately been left blank.

VIC 1.2 ACCEPTABLE CONSTRUCTION PRACTICE

Vic 1.2.0 Definitions

The following definition is used in this Part:

R or R-Value means the thermal resistance of an element of the building measured in m²K/W.

Vic 1.2.1 Application

Compliance with the provisions of **Vic Part 1.2** for energy efficiency in Class 1 buildings satisfies *Performance Requirement P2.6.1*.

Vic 1.2.2 Exemption

Vic 1.2.3(a)(iii) does not apply to—

- (a) concrete panels, cavity brick, earth wall construction, ashlar stone or other masonry walls which have a thickness (excluding any cavity) of not less than 180 mm if the floor of the building is concrete or masonry in direct contact with the ground; or
- (b) *windows*, vents and other similar openings in walls, roofs and ceilings.

Vic 1.2.3 Energy efficiency measures

- (a) The building must—
 - (i) in the case of a new building, until 30 June 2004—
 - (A) for the elements nominated in **Vic Table 1**, comply with all the *R-Values* of option A or all the *R-Values* of option B; or
 - (B) achieve a house energy rating of at least 3 stars as assessed by a person accredited in the use of—

SUPERSEDED
STATE AND TERRITORY ADDITIONS

- (aa) the FirstRate house energy rating software; or
- (bb) the Nationwide House Energy Rating Software (NatHERS);
and
- (ii) in the case of a new building, from 1 July 2004—
 - (A) achieve a house energy rating of at least 5 stars as assessed by a person accredited in the use of—
 - (aa) the FirstRate house energy rating software; or
 - (bb) the Nationwide House Energy Rating Software (NatHERS); or
 - (B) comply with Practice Note 2004-55; and
- (iii) in the case of an alteration to, or re-erection of, an existing building—
 - (A) for the elements nominated in **Vic Table 1**, comply with all the *R-values* of option A or all the *R-values* of option B; or
 - (B) achieve a house energy rating of at least 3 stars as assessed by a person accredited in the use of—
 - (aa) the FirstRate house energy rating software; or
 - (bb) the Nationwide House Energy Rating Software (NatHERS).

Vic Table 1 MINIMUM OVERALL R-VALUES

Element	Option A	Option B
Roof or ceiling	<i>R2.2</i>	<i>R2.2</i>
External wall	<i>R1.3</i>	<i>R1.7</i>
Ground Floor	<i>R1.0</i>	<i>R0.7</i>
Note:	For the purposes of this Table, a wall which separates a Class 1 building from a Class 10a building or from any roof space is regarded as an <i>external wall</i> .	

- (b) **Deemed R-Value**—An element described in **Vic Table 2** is deemed to have the *R-Value* nominated in the Table adjacent to the description of the element.

Vic Table 2 R-VALUES FOR COMMON ELEMENTS

Description of element	R-Value
Roofs or ceilings	
Tiled or metal pitched roof, <i>R2.5</i> bulk insulation between ceiling joists, lined ceiling	<i>R2.4</i>
Tiled or metal pitched roof, rfl as sarking and insulation over rafters, <i>R2.0</i> bulk insulation between ceiling joists, lined ceiling	<i>R2.2</i>
Metal deck roof, <i>R2.0</i> bulk insulation installed between rafters, rfl as a vapour barrier, ceiling lining on underside of rafters	<i>R2.2</i>
Metal deck roof, <i>R2.0</i> bulk insulation installed between roof battens, rfl as a vapour barrier, ceiling lining on top of exposed rafters	<i>R2.2</i>

SUPERSEDED
STATE AND TERRITORY ADDITIONS

Description of element	R-Value
Tiled roof, rfl as sarking and insulation, R2.0 bulk insulation installed between counter battens, optional rfl as a vapour barrier, ceiling lining on top of exposed rafters	R2.2
External walls	
Brick/masonry veneer with R1.5 bulk insulation between the studs, lined internally	R1.7
Brick/masonry veneer with R1.0 foam board fixed over the face of the studs, lined internally	R1.7
Brick/masonry veneer with double-sided rfl fixed to external face of studs, lined internally	R1.3
Weatherboard/fibre cement cladding, R1.5 bulk insulation between studs, lined internally	R1.7
Weatherboard/fibre-cement, double-sided perforated rfl dished between studs lined internally	R1.3
Cavity brick with R0.8 foam board in cavity	R1.3
150 mm concrete panel with R1.0 foam board and lined internally	R1.3
Floors	
Concrete/masonry on ground	R1.5
Timber framed floor, enclosed perimeter	R1.0
Timber framed floor, unenclosed perimeter, 20 mm foam board fixed to the underside of floor joists	R1.0
Timber framed floor, unenclosed perimeter, perforated rfl dished between joists	R1.0
Timber framed floor unenclosed perimeter	R0.7
Note: For the purposes of this Table an enclosed perimeter may incorporate sub-floor ventilation at the rate of approximately 7300 mm ² /m.	

Vic 1.2.4 Chimneys and flues

Chimneys and flues from open solid fuel-burning appliances must be provided with a damper or flap.

Vic 1.2.5 Installation of reflective foil laminate

Installation of reflective foil laminate (rfl) must comply with AS/NZS 4200.2.

SPECIAL REQUIREMENTS FOR CERTAIN BUILDINGS AND COMPONENTS
--

In addition to any applicable provisions of the Building Act 1993, the Building Regulations 1994 and *Housing Provisions*, there are a number of technical building design and construction requirements of which practitioners should be aware. The following is a list of some of these:

1. **Accommodation—Residential (boarding houses, guest houses, hostels)**
 - 1.1 Approval authority: Municipal council
 - 1.2 Relevant legislation: Health Act 1958, Health (Prescribed Accommodation) Regulations 2001
2. **Alpine Resorts—approval of construction**
 - 2.1 Approval authority: Alpine Resorts Commission
 - 2.2 Relevant legislation: Alpine Resorts Act 1983, Alpine Resorts (Management) Act 1997
3. **Crown land—construction approval**
 - 3.1 Approval authority: Crown Land and Assets Division, Department of Natural Resources and Environment
 - 3.2 Relevant legislation: Crown Land (Reserves) Act 1978
4. **Electrical installations**
 - 4.1 Authority: Electricity supply companies
 - 4.2 Relevant legislation: Electricity Industry Act 2000, State Electricity Commission Act 1958, Electricity Safety Act 1998, Electricity Safety (Installation) Regulations 1999
 - 4.3 Design codes: SAA Wiring Rules, AS/NZS 3000/3013
5. **Fences (dividing)**
 - 5.1 Relevant legislation: Fences Act 1968
 - 5.2 Appeal body: Magistrates' Court
6. **Fire prevention in existing buildings**
 - 6.1 Authority: Municipal council
 - 6.2 Relevant legislation: Building Act 1993, Building Regulations 1994, Health Act 1958
 - 6.3 Appeal body: Building Appeals Board (Building Act only)
7. **Gas installations**
 - 7.1 Approval authority: Gas and Fuel (Gascor)
 - 7.2 Relevant legislation: Gas Industry Act 2001, Gas Safety Act 1997, Gas Safety (Gas Installation) Regulations 1999
 - 7.3 Design codes: Gas Installation Code AG601 1992
8. **Historic buildings**
 - 8.1 Approval authority: Executive Director under the Heritage Act 1995
 - 8.2 Relevant legislation: Heritage Act 1995
 - 8.3 Appeal body: Heritage Council
9. **Movable dwellings (in caravan parks)**
 - 9.1 Approval authority: Municipal council

9.2 Relevant legislation: Residential Tenancies Act 1997; Residential Tenancies (Caravan Parks and Movable Dwellings Registration and Standards) Regulations 1999.

9.3 Appeals body: Building Appeals Board

10. Occupational health and safety

10.1 Approval authority: Victorian WorkCover Authority

10.2 Relevant legislation: Occupational Health and Safety Act 1985, Occupational Health and Safety (Asbestos) Regulations 2003, Health Act 1958.

10.3 Design Codes: Various Codes of practice published by the Authority

11. Planning controls

11.1 Approval authority: Municipal council, in some cases the Minister for Planning

11.2 Relevant legislation: Planning and Environment Act 1987

11.3 Design codes: Planning schemes

11.4 Appeal body: Victorian Civil and Administrative Tribunal

12. Sanitary plumbing, water supply and sewerage

12.1 Approval authority: Melbourne Water in metropolitan area, sewerage and water supply authorities in country areas

12.2 Relevant legislation: Water Industry Act 1994, Water Act 1989, Plumbing Regulations 1998

12.3 Design codes: AS/NZS 3500 National Plumbing and Drainage Code

13. Septic tank installations

13.1 Approval authority: Municipal council, Environment Protection Authority (discharge > 5000 l/day)

13.2 Relevant legislation: Environment Protection Act 1970

13.3 Design codes: Septic Tanks Code of Practice 1990

14. Subdivision of buildings

14.1 Approval authority: Municipal Council

14.2 Relevant legislation: Subdivision Act 1988

SUPERSEDED
STATE AND TERRITORY ADDITIONS

CONTENTS

WESTERN AUSTRALIA - No additional provisions

WESTERN AUSTRALIA - No additional provisions

SUPERSEDED
STATE AND TERRITORY ADDITIONS

WESTERN AUSTRALIA ADDITIONS

Western Australia has no additions to the Housing Provisions.

INDEX ABBREVIATIONS AND SYMBOLS

INDEX

Abbreviations and Symbols

INDEX CONTENTS

INDEX ABBREVIATIONS AND SYMBOLS

Index

Abbreviations and Symbols

INDEX (TO DEEMED-TO-SATISFY PROVISIONS)

A

Acceleration coefficient

[PART-3.10.2-3.10.2](#) 3.10.2 Definitions

Adobe construction

[PART-3.3.5-3.3.5](#) 3.3.5 Definitions

Air movement (energy efficiency)

[PART-3.12.4.1](#) 3.12.4.1 Air movement

Air-handling systems

[PART-3.8.5.1](#) 3.8.5.1 Application

Airlocks

[PART-3.8.5.3](#) 3.8.5.3 Location of sanitary compartments

Allowable bearing pressure (foundations)

[PART-3.2.2.3](#) 3.2.2.3 Foundations for footings and slabs

Allowable encroachments (fire safety)

[PART-3.7.1.7](#) 3.7.1.7 Allowable encroachments

Alpine areas

[PART-3.7.5.1](#) 3.7.5.1 Application

Aluminium structures

[PART-3.11.6](#) 3.11.6 Determination of structural resistance of materials and forms of construction

Articulated masonry

[PART-3.2-3.2](#) 3.2 Definitions

Articulation joints

[PART-3.3.1.8](#) 3.3.1.8 Vertical articulation joints

Artificial lighting

[PART-3.8.4.3](#) 3.8.4.3 Artificial lighting

Asphalt shingles

[PART-3.5.1.0](#) 3.5.1.0 Acceptable construction manuals

B

Balcony (balustrades)

[PART-3.9.2.1](#) 3.9.2.1 Application

Balustrades and barriers

[PART-3.9.2.1](#) 3.9.2.1 Application

Baths

[PART-3.8.3.1](#) 3.8.3.1 Application

BCA application

[PART-1.0.1](#) 1.0.1 Adoption

BCA application (adoption of Standards)

[PART-1.1.2](#) 1.1.2 Adoption of referenced documents

Bond beams

[PART-3.3.2.2](#) 3.3.2.2 External wall construction

Borrowed light

[PART-3.8.4.1](#) 3.8.4.1 Application

Breeze paths

[PART-3.12.4.2](#) 3.12.4.2 Ventilation openings

Brick ties

[PART-3.3.3.1](#) 3.3.3.1 Application

Building classification

[PART-1.3.1](#) 1.3.1 Principles of classification

Building fabric

[PART-3.12.1.3.12.1](#) 3.12.1 Application

Building sealing (energy efficiency)

[PART-3.12.3-3.12.3](#) 3.12.3 Application

Bulk insulation (energy efficiency)

[PART-3.12.1.1.3.12.1.1](#) 3.12.1.1 Building fabric insulation

Bulletin 5

[PART-3.3.5-3.3.5](#) 3.3.5 Definitions

Bushfire prone areas

[PART-3.7.4.1](#) 3.7.4.1 Application

C

Carpports (fire safety)

[PART-3.7.1.6](#) 3.7.1.6 Class 10a buildings

Cavity width

[PART-3.3.4.2](#) 3.3.4.2 Width of cavity

Ceiling fans

[PART-3.12.4.3](#) 3.12.4.3 Ceiling fans and evaporative coolers

Ceiling heights

[PART-3.8.2.1](#) 3.8.2.1 Application

Ceiling insulation (energy efficiency)

[PART-3.12.1.2](#) 3.12.1.2 Roofs

Central heating

[PART-3.12.5.2](#) 3.12.5.2 Central heating water piping

Chimney construction

[PART-3.7.3.3](#) 3.7.3.3 Chimney construction

Chimneys and flues (energy efficiency)

[PART-3.12.3.1](#) 3.12.3.1 Chimneys and flues

Clad frame

[PART-3.2-3.2](#) 3.2 Definitions

Class 10a buildings (energy efficiency)

[PART-3.12.1.6](#) 3.12.1.6 Attached Class 10a buildings

Class 10a buildings (fire safety)

[PART-3.7.1.6](#) 3.7.1.6 Class 10a buildings

Climate Zone map

[PART-1.1.1](#) 1.1.1 Definitions

Clothes washing facilities

[PART-3.8.3.1](#) 3.8.3.1 Application

Columns (structural steel)

[PART-3.4.4.3](#) 3.4.4.3 Columns

Composite steel and concrete

[PART-3.11.6](#) 3.11.6 Determination of structural resistance of materials and forms of construction

Concrete

[PART-3.2.3.1](#) 3.2.3.1 Concrete

Concrete roof tiles

[PART-3.5.1.1](#) 3.5.1.1 Application

Concrete structures

[PART-3.11.6](#) 3.11.6 Determination of structural resistance of materials and forms of construction

Conditioned space

[PART-3.12-3.12](#) 3.12 Definitions

Construction (earthquake areas)

[PART-3.10.2.1](#) 3.10.2.1 Application

Controlled fill

[PART-3.2-3.2](#) 3.2 Definitions

Corrosion protection (metal sheet roofing)

[PART-3.5.1.3](#) 3.5.1.3 Metal sheet roofing

Corrosion protection (steel framing)

[PART-3.4.2.2](#) 3.4.2.2 General

Corrosion protection (steel)

[PART-3.4.4.4](#) 3.4.4.4 Corrosion protection

Corrosion protection (wall ties)

[PART-3.3.3.2](#) 3.3.3.2 Wall ties

Cyclonic areas

[PART-3.10.1.0](#) 3.10.1.0 Acceptable construction manual

D

Damp proof courses

[PART-3.3.4.4](#) 3.3.4.4 Damp-proof courses - materials

Damp-proof course (DPC)

[PART-3.3.4.1](#) 3.3.4.1 Application

Damp-proofing (slab on ground)

[PART-3.2.2.1](#) 3.2.2.1 Excavation for footings

Definitions

[PART-1.1.1](#) 1.1.1 Definitions

Design category

[PART-3.10.2-3.10.2](#) 3.10.2 Definitions

Design suitability

[PART-1.2.2](#) 1.2.2 Evidence of suitability

Diagrams (interpretation)

[PART-1.1.7](#) 1.1.7 Interpretation of diagrams

Domestic services (energy efficiency)

[PART-3.12.5.1](#) 3.12.5.1 Insulation of services

Doors (energy efficiency)

[PART-3.12.3.3](#) 3.12.3.3 External windows and doors

Doors (glass)

[PART-3.6.5](#) 3.6.5 Doors

Downpipes

[PART-3.5.2.1](#) 3.5.2.1 Application

Drainage

PART-3.1.1.0 3.1.1.0 Application

PART-3.1.2.1 3.1.2.1 Application

Drainage (roofs)

PART-3.5.2.1 3.5.2.1 Application

Ductwork (fire properties)

PART-3.7.1.9 3.7.1.9 Fire hazard properties

E

Early fire hazard indices

PART-1.2.4 1.2.4 Early Fire Hazard Indices

PART-3.7.1.9 3.7.1.9 Fire hazard properties

Earthquake areas

PART-3.10.2.1 3.10.2.1 Application

Earthwall construction

PART-3.3.5-3.3.5 3.3.5 Definitions

PART-3.3.5.1 3.3.5.1 Application

Earthworks

PART-3.1.1.0 3.1.1.0 Application

PART-3.1.1.1 3.1.1.1 Earthworks

Eaves and soffit linings

PART-3.5.3.5 3.5.3.5 Eaves and soffit linings

Edge beams

PART-3.2.2.4 3.2.2.4 Slab edge support on sloping sites

PART-3.2.5.4 3.2.5.4 Minimum edge beam dimensions

Edge rebates

PART-3.2.2.7 3.2.2.7 Edge rebates

Enclosed shower

PART-3.8.1-3.8.1 3.8.1 Definitions

Energy efficiency

PART-3.12.1.3.12.1 3.12.1 Application

Energy efficiency (building fabric)

PART-3.12.1.3.12.1 3.12.1 Application

Energy efficiency (building sealing)

PART-3.12.3-3.12.3 3.12.3 Application

Energy efficiency (Class 10a)

[PART-3.12.1.6](#) 3.12.1.6 Attached Class 10a buildings

Evaporative coolers

[PART-3.12.4.3](#) 3.12.4.3 Ceiling fans and evaporative coolers

Evidence of suitability

[PART-1.2.2](#) 1.2.2 Evidence of suitability

Excavation

[PART-3.1.1.2](#) 3.1.1.2 Excavation adjacent to vacant adjoining property

[PART-3.1.1.3](#) 3.1.1.3 Excavation adjacent to existing buildings

Excavation (footings)

[PART-3.2.2.1](#) 3.2.2.1 Excavation for footings

Exhaust fans (energy efficiency)

[PART-3.12.3.4](#) 3.12.3.4 Exhaust fans

Exhaust ventilation (closet pans, kitchens)

[PART-3.8.5.1](#) 3.8.5.1 Application

Existing buildings (footings and slabs)

[PART-3.2.5.2](#) 3.2.5.2 Footings and slabs to extensions to existing buildings

Exit (alpine areas)

[PART-3.7.5.1](#) 3.7.5.1 Application

Explanatory information

[PART-1.1.8](#) 1.1.8 Explanatory information

External glazing (energy efficiency)

[PART-3.12.2-3.12.2](#) 3.12.2 Application

External stairways

[PART-3.9.1.1](#) 3.9.1.1 Application

External wall (bond beam)

[PART-3.3.2.2](#) 3.3.2.2 External wall construction

External wall (fire resistance)

[PART-3.7.1.1](#) 3.7.1.1 Application

External wall (lintels)

[PART-3.3.2.2](#) 3.3.2.2 External wall construction

External wall (reinforced masonry)

[PART-3.3.2.2](#) 3.3.2.2 External wall construction

External walls (energy efficiency)

[PART-3.12.1.4](#) 3.12.1.4 External walls

External walls (fire safety)

PART-3.7.1.3 3.7.1.3 External walls of Class 1 buildings

PART-3.7.1.5 3.7.1.5 Construction of external walls

External walls (masonry)

PART-3.3.1.2 3.3.1.2 External walls

F

Fibre cement wall cladding

PART-3.5.3.3 3.5.3.3 Fibre cement planks and weatherboard cladding

Fibre sheeting

PART-3.5.1.1 3.5.1.1 Application

Fill

PART-3.1.1.4 3.1.1.4 Fill

Fill (under slabs)

PART-3.2.2.2 3.2.2.2 Filling under concrete slabs

Finished ground level

PART-3.2-3.2 3.2 Definitions

Fire hazard properties

PART-3.7.1.9 3.7.1.9 Fire hazard properties

Fire resistance (building elements)

PART-1.2.3 1.2.3 Fire resistance of building elements

Fire resisting construction

PART-3.7.1.1 3.7.1.1 Application

Fire safety

PART-3.7.1.1 3.7.1.1 Application

PART-3.7.3.1 3.7.3.1 Application

Fire safety (alpine areas)

PART-3.7.5.1 3.7.5.1 Application

Fire safety (bushfire prone areas)

PART-3.7.4.1 3.7.4.1 Application

Fire separation

PART-3.7.1.1 3.7.1.1 Application

Fireplaces (energy efficiency)

PART-3.12.3.1 3.12.3.1 Chimneys and flues

Fireplaces (footings)

PART-3.2.5.1 3.2.5.1 Footing and slab construction

PART-3.2.5.5 3.2.5.5 Footings for fireplaces on Class A and S sites

Fixing straps and tie down systems

PART-3.3.3.3 3.3.3.3 Fixing straps and tie down systems

Flashings

PART-3.3.4.1 3.3.4.1 Application

PART-3.3.4.6 3.3.4.6 Flashings

Flashings (roofing)

PART-3.5.1.3 3.5.1.3 Metal sheet roofing

Flashings (wall openings)

PART-3.5.3.6 3.5.3.6 Flashings to wall openings

Flight

PART-3.9.1a 3.9.1 Definitions

Floors (damproofing)

PART-3.2.2.1 3.2.2.1 Excavation for footings

Floors (energy efficiency)

PART-3.12.1.5 3.12.1.5 Floors

Floors (sealing for energy efficiency)

PART-3.12.3.5 3.12.3.5 Construction of roofs, walls and floors

Floors (sub-floor ventilation)

PART-3.4.1.1 3.4.1.1 Application

Flues, chimneys and fireplaces

PART-3.7.3.1 3.7.3.1 Application

Footing

PART-3.2-3.2 3.2 Definitions

Footing and slab construction

PART-3.2.5.1 3.2.5.1 Footing and slab construction

Footings (stepped)

PART-3.2.2.5 3.2.2.5 Stepped footings

Footings and slabs

PART-3.2.1 3.2.1 Application

PART-3.2.2.1 3.2.2.1 Excavation for footings

Foundations (footings and slabs)

PART-3.2.2.3 3.2.2.3 Foundations for footings and slabs

Framing (steel)

[PART-3.4.2.1](#) 3.4.2.1 Application

Framing (timber)

[PART-3.4.3.0](#) 3.4.3.0 Acceptable construction manual

Framing connector

[PART-3.10.2-3.10.2](#) 3.10.2 Definitions

G

Glass (human impact)

[PART-3.6.4](#) 3.6.4 Human impact safety requirements

Glazing

[PART-3.6.0](#) 3.6.0 Acceptable construction manuals

[PART-3.6.1](#) 3.6.1 Application

Glazing area limits (energy efficiency)

[PART-3.12.2.1](#) 3.12.2.1 External glazing

Going

[PART-3.9.1a](#) 3.9.1 Definitions

GRP sheeting

[PART-3.5.1.1](#) 3.5.1.1 Application

Gutters and downpipes

[PART-3.5.2.1](#) 3.5.2.1 Application

H

Habitable room (ceiling heights)

[PART-3.8.2.1](#) 3.8.2.1 Application

Habitable room (natural light)

[PART-3.8.4.1](#) 3.8.4.1 Application

Habitable room (sound insulation)

[PART-3.8.6.1](#) 3.8.6.1 Application

Hearths

[PART-3.7.3.1](#) 3.7.3.1 Application

Heated floor slabs

[PART-3.12.1.5](#) 3.12.1.5 Floors

Heating and cooling ductwork

[PART-3.12.5.3](#) 3.12.5.3 Heating and cooling ductwork

Heating appliances

PART-3.7.3.5 3.7.3.5 Installation of free standing heating appliances

Heating appliances (energy efficiency)

PART-3.12.3.1 3.12.3.1 Chimneys and flues

Heating appliances (fire safety)

PART-3.7.3.1 3.7.3.1 Application

High wind areas

PART-3.10.1.0 3.10.1.0 Acceptable construction manual

High wind areas Cyclonic areas

PART-3.10.1.0 3.10.1.0 Acceptable construction manual

Hot water supply systems

PART-3.12.5.0 3.12.5.0 Acceptable construction manual

Human impact (glass)

PART-3.6.4 3.6.4 Human impact safety requirements

I

Impact sound

PART-3.8.6.1 3.8.6.1 Application

Imposed actions (structural)

PART-3.11.1 3.11.1 Application

Insulation (ductwork)

PART-3.12.5.3 3.12.5.3 Heating and cooling ductwork

Insulation (energy efficiency)

PART-3.12.1.1.3.12.1.1 3.12.1.1 Building fabric insulation

Insulation (services, energy efficiency)

PART-3.12.5.1 3.12.5.1 Insulation of services

Internal walls (unreinforced masonry)

PART-3.3.1.3 3.3.1.3 Internal walls

Interpretation of diagrams

PART-1.1.7 1.1.7 Interpretation of diagrams

Isolated piers

PART-3.3.1.4 3.3.1.4 Isolated piers

K

Kitchen exhaust

PART-3.8.5.1 3.8.5.1 Application

Kitchen facilities

[PART-3.8.3.1](#) 3.8.3.1 Application

L

Ladders

[PART-3.9.1.1](#) 3.9.1.1 Application

Landing

[PART-3.9.1a](#) 3.9.1 Definitions

Landings

[PART-3.9.1.1](#) 3.9.1.1 Application

[PART-3.9.2.1](#) 3.9.2.1 Application

Language

[PART-1.1.6](#) 1.1.6 Language

Laundry (waterproofing)

[PART-3.8.1.0](#) 3.8.1.0 Acceptable construction manual

Light

[PART-3.8.4.1](#) 3.8.4.1 Application

Light (artificial)

[PART-3.8.4.3](#) 3.8.4.3 Artificial lighting

Light (natural)

[PART-3.8.4.2](#) 3.8.4.2 Natural lighting

Lintels

[PART-3.3.2.2](#) 3.3.2.2 External wall construction

[PART-3.3.3.1](#) 3.3.3.1 Application

[PART-3.3.3.4](#) 3.3.3.4 Lintels

[PART-3.4.4.1](#) 3.4.4.1 Application

Loadbearing wall

[PART-3.2-3.2](#) 3.2 Definitions

Loads (structural)

[PART-3.11.1](#) 3.11.1 Application

M

Masonry (reinforced)

[PART-3.3.2.1](#) 3.3.2.1 Application

Masonry (unreinforced)

[PART-3.3.1.1](#) 3.3.1.1 Application

Masonry (unreinforced, articulation joints)

[PART-3.3.1.8](#) 3.3.1.8 Vertical articulation joints

Masonry (weatherproofing)

[PART-3.3.4.1](#) 3.3.4.1 Application

Masonry accessories

[PART-3.3.3.1](#) 3.3.3.1 Application

Masonry units

[PART-3.3.1.5](#) 3.3.1.5 Masonry units

Masonry-veneer external walls

[PART-3.3.1.2](#) 3.3.1.2 External walls

Materials (non-combustible)

[PART-3.7.1.2](#) 3.7.1.2 General concession—non-combustible materials

Materials (suitability)

[PART-1.2.1](#) 1.2.1 Suitability of materials

Mechanically pressed-soil block construction

[PART-3.3.5-3.3.5](#) 3.3.5 Definitions

Metal sheet roofing

[PART-3.5.1.3](#) 3.5.1.3 Metal sheet roofing

Mixed construction

[PART-3.2-3.2](#) 3.2 Definitions

Moisture barriers

[PART-3.2.2.6](#) 3.2.2.6 Vapour barriers

Mortar joints

[PART-3.3.1.7](#) 3.3.1.7 Mortar joints

Mortar mixes

[PART-3.3.1.6](#) 3.3.1.6 Mortar mixes

Multiple classifications

[PART-1.3.3](#) 1.3.3 Multiple classifications

N

Natural light

[PART-3.8.4.2](#) 3.8.4.2 Natural lighting

Natural ventilation

[PART-3.8.5.2](#) 3.8.5.2 Ventilation requirements

Non-combustible materials

[PART-3.7.1.2](#) 3.7.1.2 General concession—non-combustible materials

O

Open fireplace construction

[PART-3.7.3.2](#) 3.7.3.2 Open fireplace construction

Openings in external walls

[PART-3.7.1.3](#) 3.7.1.3 External walls of Class 1 buildings

Orientation factor (glazing)

[PART-3.12.2.1](#) 3.12.2.1 External glazing

P

Perimeter of building

[PART-3.6-3.6](#) 3.6 Definitions

Piled footing

[PART-3.2.1](#) 3.2.1 Application

Pipe insulation (central heating)

[PART-3.12.5.2](#) 3.12.5.2 Central heating water piping

Pipes (sound insulation)

[PART-3.8.6.4](#) 3.8.6.4 Services

Piping

[PART-3.12-3.12](#) 3.12 Definitions

Prefinished shower base

[PART-3.8.1-3.8.1](#) 3.8.1 Definitions

Primary building element

[PART-3.1.3-PART-3.1](#) 3.1 Definitions

Principles of classification

[PART-1.3.1](#) 1.3.1 Principles of classification

Protection of openings

[PART-3.7.1.1](#) 3.7.1.1 Application

PVC sheeting

[PART-3.5.1.1](#) 3.5.1.1 Application

R

R-Value

[PART-3.12-3.12](#) 3.12 Definitions

Rainwater tanks

[PART-3.7.1.7](#) 3.7.1.7 Allowable encroachments

Rammed-earth construction

[PART-3.3.5-3.3.5](#) 3.3.5 Definitions

Referenced documents

[PART-1.4.1](#) 1.4.1 Schedule of referenced documents

Reflective insulation

[PART-3.12-3.12](#) 3.12 Definitions

[PART-3.12.1.1.3.12.1.1](#) 3.12.1.1 Building fabric insulation

Reinforced masonry

[PART-3.3.2.1](#) 3.3.2.1 Application

Reinforcing (concrete)

[PART-3.2.3.1](#) 3.2.3.1 Concrete

Riser

[PART-3.9.1a](#) 3.9.1 Definitions

Risers and goings

[PART-3.9.1.4](#) 3.9.1.4 Riser and going dimensions

Rolled fill

[PART-3.2-3.2](#) 3.2 Definitions

Roof cladding

[PART-3.5.1.1](#) 3.5.1.1 Application

Roof insulation

[PART-3.12.1.2](#) 3.12.1.2 Roofs

Roof lights (energy efficiency)

[PART-3.12.1.3](#) 3.12.1.3 Roof lights

[PART-3.12.3.2](#) 3.12.3.2 Roof lights

Roof lights (fire safety)

[PART-3.7.1.10](#) 3.7.1.10 Roof lights

Roof tiling

[PART-3.5.1.2](#) 3.5.1.2 Roof tiling

Roof ventilation (energy efficiency)

[PART-3.12.1.2](#) 3.12.1.2 Roofs

Roofs (sealing for energy efficiency)

[PART-3.12.3.5](#) 3.12.3.5 Construction of roofs, walls and floors

Room heights

[PART-3.8.2.1](#) 3.8.2.1 Application

S

Sanitary compartment (waterproofing)

[PART-3.8.1.0](#) 3.8.1.0 Acceptable construction manual

Sanitary compartments

[PART-3.8.3.3](#) 3.8.3.3 Construction of sanitary compartments

Sanitary compartments (location and ventilation)

[PART-3.8.5.3](#) 3.8.5.3 Location of sanitary compartments

Sanitary facilities

[PART-3.8.3.1](#) 3.8.3.1 Application

Sarking-type materials

[PART-3.7.1.9](#) 3.7.1.9 Fire hazard properties

Separating walls

[PART-3.7.1.8](#) 3.7.1.8 Separating walls

Services (energy efficiency)

[PART-3.12.5.1](#) 3.12.5.1 Insulation of services

Services (sound insulation)

[PART-3.8.6.4](#) 3.8.6.4 Services

Services (steel framing)

[PART-3.4.2.6](#) 3.4.2.6 Installation of services

Shading (energy efficiency)

[PART-3.12.2.2](#) 3.12.2.2 Shading

Sheet wall cladding

[PART-3.5.3.4](#) 3.5.3.4 Sheet wall cladding

Shower enclosure

[PART-3.8.1.0](#) 3.8.1.0 Acceptable construction manual

Shower screens

[PART-3.6.9](#) 3.6.9 Shower doors, shower screens and bath enclosures

Shower tray

[PART-3.8.1-3.8.1](#) 3.8.1 Definitions

Showers

[PART-3.8.3.1](#) 3.8.3.1 Application

Shrinkage (timber framing)

[PART-3.3.1.10](#) 3.3.1.10 Shrinkage allowance for timber framing

Shrinkage control

[PART-3.2.5.3](#) 3.2.5.3 Shrinkage control

Single leaf masonry

[PART-3.2-3.2](#) 3.2 Definitions

Site classification

[PART-3.2.4.1](#) 3.2.4.1 Site classification

Siteworks

[PART-3.1.1.0](#) 3.1.1.0 Application

Siteworks (drainage)

[PART-3.1.2.1](#) 3.1.2.1 Application

Slab (edge insulation)

[PART-3.12.1.5](#) 3.12.1.5 Floors

Slab edge support

[PART-3.2.2.4](#) 3.2.2.4 Slab edge support on sloping sites

Slabs

[PART-3.2.5.1](#) 3.2.5.1 Footing and slab construction

Smoke alarms

[PART-3.7.2.1](#) 3.7.2.1 Application

Snow areas (fire safety)

[PART-3.7.5.1](#) 3.7.5.1 Application

Snow loads

[PART-3.11.1](#) 3.11.1 Application

Sound insulation

[PART-3.8.6.1](#) 3.8.6.1 Application

Spiral stair

[PART-3.9.1a](#) 3.9.1 Definitions

Stair construction

[PART-3.9.1.1](#) 3.9.1.1 Application

Stairway (balustrades)

[PART-3.9.2.1](#) 3.9.2.1 Application

Standards

[PART-1.1.2](#) 1.1.2 Adoption of referenced documents

[PART-1.4.1](#) 1.4.1 Schedule of referenced documents

Steel (corrosion protection)

[PART-3.4.4.4](#) 3.4.4.4 Corrosion protection

Steel (structural members)

[PART-3.4.4.1](#) 3.4.4.1 Application

Steel columns

[PART-3.4.4.3](#) 3.4.4.3 Columns

Steel floor framing

[PART-3.4.2.3](#) 3.4.2.3 Steel floor framing

Steel framing

[PART-3.4.2.1](#) 3.4.2.1 Application

Steel framing (corrosion protection)

[PART-3.4.2.2](#) 3.4.2.2 General

Steel reinforcement

[PART-3.2.3.2](#) 3.2.3.2 Steel reinforcement

Stepped footings

[PART-3.2.2.5](#) 3.2.2.5 Stepped footings

Stormwater drainage

[PART-3.1.2.1](#) 3.1.2.1 Application

[PART-3.5.2.1](#) 3.5.2.1 Application

Structural (earthquake areas)

[PART-3.10.2.1](#) 3.10.2.1 Application

[PART-3.11.1](#) 3.11.1 Application

Structural steel members

[PART-3.4.4.1](#) 3.4.4.1 Application

Stump footings

[PART-3.2.5.6](#) 3.2.5.6 Stump footing details

Sub-floor ventilation

[PART-3.3.1.9](#) 3.3.1.9 Sub-floor ventilation

[PART-3.4.1.1](#) 3.4.1.1 Application

Suitability of materials

[PART-1.2.1](#) 1.2.1 Suitability of materials

Swimming pools

[PART-3.9.3.1](#) 3.9.3.1 Application

T

Tapered tread

[PART-3.9.1a](#) 3.9.1 Definitions

Termite barriers

[PART-3.1.3.2](#) 3.1.3.2 Installation of termite barriers

Termite barriers (slab-on-ground)

[PART-3.1.3.3](#) 3.1.3.3 Barriers for concrete slab-on-ground

Termite barriers (suspended floor)

[PART-3.1.3.4](#) 3.1.3.4 Barriers for suspended floors

Termite shields (damp proof course)

[PART-3.3.4.4](#) 3.3.4.4 Damp-proof courses - materials

Termites

[PART-3.1-3.1.3](#) 3.1.3 Application

Terracota roof tiles

[PART-3.5.1.1](#) 3.5.1.1 Application

Thresholds

[PART-3.9.1.5](#) 3.9.1.5 Threshold

Tie down straps

[PART-3.3.3.3](#) 3.3.3.3 Fixing straps and tie down systems

Timber framing

[PART-3.4.3.0](#) 3.4.3.0 Acceptable construction manual

Timber framing (shrinkage, masonry veneer)

[PART-3.3.1.10](#) 3.3.1.10 Shrinkage allowance for timber framing

Timber wall cladding

[PART-3.5.3.2](#) 3.5.3.2 Timber weatherboard cladding

Total R-Value

[PART-3.12-3.12](#) 3.12 Definitions

Total U-Value

[PART-3.12-3.12](#) 3.12 Definitions

Treads

[PART-3.9.1.4](#) 3.9.1.4 Riser and going dimensions

U

Unobstructed opening

[PART-3.6-3.6](#) 3.6 Definitions

Unreinforced masonry

[PART-3.3.1.1](#) 3.3.1.1 Application

V

Vapour barriers

[PART-3.2.2.1](#) 3.2.2.1 Excavation for footings

[PART-3.2.2.6](#) 3.2.2.6 Vapour barriers

Ventilation

[PART-3.8.5.1](#) 3.8.5.1 Application

Ventilation (sub-floor)

[PART-3.3.1.9](#) 3.3.1.9 Sub-floor ventilation

[PART-3.4.1.1](#) 3.4.1.1 Application

Ventilation opening

[PART-3.12-3.12](#) 3.12 Definitions

Ventilation openings

[PART-3.12.4.2](#) 3.12.4.2 Ventilation openings

Vertical articulation joints

[PART-3.3.1.8](#) 3.3.1.8 Vertical articulation joints

W

W et area fixture

[PART-3.8.1-3.8.1](#) 3.8.1 Definitions

Waffle raft

[PART-3.2-3.2](#) 3.2 Definitions

Wall cladding

[PART-3.5.3.1](#) 3.5.3.1 Application

Wall ties

[PART-3.3.3.1](#) 3.3.3.1 Application

[PART-3.3.3.2](#) 3.3.3.2 Wall ties

Walls (sealing for energy efficiency)

[PART-3.12.3.5](#) 3.12.3.5 Construction of roofs, walls and floors

Washbasins

[PART-3.8.3.1](#) 3.8.3.1 Application

Water resistant

[PART-3.8.1-3.8.1](#) 3.8.1 Definitions

Waterproof

[PART-3.8.1-3.8.1](#) 3.8.1 Definitions

Waterproof membrane

[PART-3.8.1-3.8.1](#) 3.8.1 Definitions

Waterproofing

PART-3.8.1.0 3.8.1.0 Acceptable construction manual

Weatherproofing (masonry)

PART-3.3.4.1 3.3.4.1 Application

Weepholes (bushfire prone areas)

PART-3.7.4.1 3.7.4.1 Application

Weighted sound reduction index

PART-3.8.6.1 3.8.6.1 Application

Wet area

PART-3.8.1-3.8.1 3.8.1 Definitions

Wet areas

PART-3.8.1.0 3.8.1.0 Acceptable construction manual

Width of cavity

PART-3.3.4.2 3.3.4.2 Width of cavity

Winders

PART-3.9.1a 3.9.1 Definitions

Windows (energy efficiency)

PART-3.12.3.3 3.12.3.3 External windows and doors

Windows (natural light)

PART-3.8.4.2 3.8.4.2 Natural lighting

SUPERSEDED
INDEX ABBREVIATIONS AND SYMBOLS

ABBREVIATIONS AND SYMBOLS

Abbreviations and Symbols used in the *Housing Provisions* include:

ABBREVIATIONS

ABCB	Australian Building Codes Board
AISC	Australian Institute of Steel Construction
ALGA	Australian Local Government Association
AS	Australian Standard
ASTM	American Society for Testing and Materials
BCA	Building Code of Australia
BCC	Building Codes Committee
BERS	Building energy rating software
CSIRO	Commonwealth Scientific and Industrial Research Organisation
DBC&E	CSIRO Division of Building, Construction and Engineering
FirstRate	FirstRate house energy rating software
FRL	Fire Resistance Level
GRP	glass fibre reinforced polyester
IG	Insulating glass unit
ISO	International Organisation for Standardisation
Low-e	Low emissivity
NATA	National Association of Testing Authorities
NatHERS	National House Energy Rating Scheme
NBTC	CSIRO National Building Technology Centre
Pa	Pascal
PVC	polyvinyl chloride
R_w	Weighted Sound Reduction Index
RBM	Reflective building membrane
R-Value	Thermal resistance co-efficient
SHGC	Solar heat gain co-efficient
STC	Sound Transmission Class
SSL	Scientific Services Laboratory
UPVC	Unplasticised polyvinyl chloride
U-Value	Heat transfer co-efficient

SUPERSEDED
INDEX ABBREVIATIONS AND SYMBOLS

SYMBOLS AND SI UNITS

°C	degree(s) Celsius
g/m ²	gram(s) per square metre
K	kelvin(s)
kg	kilogram(s)
kg/m	kilogram(s) per metre
kg/m ²	kilogram(s) per square metre
kg/m ³	kilogram(s) per cubic metre
km	kilometre
kPa	kilopascal(s)
kW/m ²	kilowatt(s) per square metre
L	litre(s)
L/s	litre(s) per second
L/s.m ²	litre(s) per second square metre
lx	lux
∅	diameter
F	in relation to steel members means steel fabric
m	metre(s)
m ²	square metre(s)
m ³	cubic metre(s)
m/s	metre(s) per second
m ³ /s	cubic metre(s) per second
mm	millimetre(s)
mm ²	square millimetre(s)
um	micrometer
Mj/m ² .annum	megajoule(s) per square metre per annum
MW	megawatt(s)
N	newton(s)
Pa	pascal(s)
MPa	megapascal(s)
°south	degree south
%	percent
>	greater than
<	less than
≤	equal to or less than
≥	equal to or more than

HISTORY OF AMENDMENTS

CONTENTS

HISTORY OF AMENDMENTS

History of amendments

- 1.0 Adoption of BCA96
- 1.1 Amendment No. 1
- 1.2 Amendment No. 2
- 1.3 Amendment No. 3
- 1.4 Amendment No. 4
- 1.5 Amendment No. 5
- 1.6 Amendment No. 6
- 1.7 Amendment No. 7
- 1.8 Amendment No. 8
- 1.9 Amendment No. 9
- 1.10 Amendment No. 10
- 1.11 Amendment No. 11
- 1.12 Amendment No. 12
- 1.13 Amendment No. 13
- 2.0 Adoption of BCA 2004

HISTORY OF BCA ADOPTION

1.0 Adoption of BCA96

The 1996 edition of the BCA was adopted as set out in Table 1.0.

Table 1.0 History of adoption of BCA96

Administration	Adoption Date
Australian Government	1 July 1997
Australian Capital Territory	1 July 1997
New South Wales	1 July 1997
Northern Territory	7 January 1998
Queensland	1 July 1997
South Australia	1 January 1998
Tasmania	1 July 1997
Victoria	1 August 1997
Western Australia	1 July 1997

1.1 Amendment No. 1

(a) Amendment No. 1 of the 1996 edition of the BCA was adopted as set out in Table 1.1.

Table 1.1 History of adoption of Amendment No. 1 of BCA96

Administration	Adoption Date
Australian Government	1 July 1997
Australian Capital Territory	1 July 1997
New South Wales	1 July 1997
Northern Territory	7 January 1998
Queensland	1 July 1997
South Australia	1 January 1998
Tasmania	1 July 1997
Victoria	1 August 1997
Western Australia	1 July 1997

(b) The purpose of Amendment No. 1 is to—

- (i) include typographical changes including spelling, punctuation, cross references and layout; and
- (ii) include reference to a *Certificate of Conformity* issued by the ABCB in A2.2; and

- (iii) change the reference to the Standards Mark Certificate to refer to JAS–ANZ in A2.2; and
- (iv) update references to Standards.

Note:

The revisions contained in Amendment No. 1 to the *Housing Provisions* have not been marked in the text.

1.2 Amendment No. 2

- (a) Amendment No. 2 of the 1996 edition of the BCA was adopted as set out in Table 1.2.

Table 1.2 History of adoption of Amendment No. 2 of BCA96

Administration	Adoption Date
Australian Government	1 January 1998
Australian Capital Territory	1 January 1998
New South Wales	27 February 1998
Northern Territory	7 January 1998
Queensland	1 January 1998
South Australia	1 January 1998
Tasmania	1 January 1998
Victoria	1 January 1998
Western Australia	1 January 1998

- (b) The purpose of Amendment No. 2 is to—
 - (i) include typographical changes including spelling, punctuation, cross references and layout; and
 - (ii) update references to Standards; and
 - (iii) include minor technical changes.

1.3 Amendment No. 3

- (a) Amendment No. 3 of the 1996 edition of the BCA was adopted as set out in Table 1.3.

Table 1.3 History of adoption of Amendment No. 3 of BCA96

Administration	Adoption Date
Australian Government	1 July 1998
Australian Capital Territory	1 July 1998
New South Wales	1 July 1998
Northern Territory	1 July 1998
Queensland	1 July 1998
South Australia	13 July 1998

Administration	Adoption Date
Tasmania	1 July 1998
Victoria	1 July 1998
Western Australia	1 July 1998

- (b) The purpose of Amendment No. 3 is to—
- (i) incorporate the outcomes of the 1997 ABCB Variations Conference; and
 - (ii) update references to Standards; and
 - (iii) include minor technical changes.

1.4 Amendment No. 4

- (a) Amendment No. 4 of the 1996 edition of the BCA was adopted as set out in Table 1.4.

Table 1.4 History of adoption of Amendment No. 4 of BCA96

Administration	Adoption Date
Australian Government	1 January 1999
Australian Capital Territory	17 May 1999
New South Wales	1 February 1999
Northern Territory	1 January 1999
Queensland	1 January 1999
South Australia	1 January 1999
Tasmania	1 January 1999
Victoria	1 January 1999
Western Australia	1 January 1999

- (b) The purpose of Amendment No. 4 is to—
- (i) update references to standards; and
 - (ii) include minor technical changes.

1.5 Amendment No. 5

- (a) Amendment No. 5 of the 1996 edition of the BCA was adopted as set out in Table 1.5.

Table 1.5 History of adoption of Amendment No. 5 of BCA96

Administration	Adoption Date
Australian Government	1 July 1999
Australian Capital Territory	3 November 1999
New South Wales	1 August 1999
Northern Territory	1 July 1999
Queensland	1 July 1999

Administration	Adoption Date
South Australia	1 July 1999
Tasmania	1 July 1999
Victoria	1 July 1999
Western Australia	1 July 1999

- (b) The purpose of Amendment No. 5 is to—
- (i) update references to standards; and
 - (ii) expand on the requirements for sub-floor ventilation based on climatic conditions; and
 - (iii) revise the Acceptable Construction Practice for Steel framing; and
 - (iv) include additional details in the Acceptable Construction Practice for fencing of swimming pools; and
 - (v) include minor technical changes.

1.6 Amendment No. 6

- (a) Amendment No. 6 of the 1996 edition of the BCA was adopted as set out in Table 1.6.

Table 1.6 History of adoption of Amendment No. 6 of BCA96

Administration	Adoption Date
Australian Government	1 January 2000
Australian Capital Territory	10 February 2000
New South Wales	1 January 2000
Northern Territory	1 January 2000
Queensland	1 January 2000
South Australia	17 January 2000
Tasmania	1 January 2000
Victoria	1 January 2000
Western Australia	1 January 2000

- (b) The purpose of Amendment No. 6 is to—
- (i) update references to standards; and
 - (ii) revise the Acceptable Construction Practice for Footing and Slab Construction; and
 - (iii) replace Sound Transmission Class (STC) with weighted sound reduction index (R_w) within Part 3.8.6; and
 - (iv) include minor technical changes.

1.7 Amendment No. 7

- (a) Amendment No. 7 of the 1996 edition of the BCA was adopted as set out in Table 1.7.

Table 1.7 History of adoption of Amendment No. 7 of BCA96

Administration	Adoption Date
Australian Government	1 July 2000
Australian Capital Territory	10 July 2000
New South Wales	1 July 2000
Northern Territory	1 July 2000
Queensland	1 July 2000
South Australia	1 July 2000
Tasmania	1 July 2000
Victoria	1 July 2000
Western Australia	1 July 2000

- (b) The purpose of Amendment No. 7 is to—
- (i) update references to standards; and
 - (ii) include requirements for separation of eaves and verandah spaces that are open to the roof space and common to 2 or more Class 1 buildings; and
 - (iii) reinstate the Acceptable Construction Practice for buildings in bushfire-prone areas, following alignment with the 1999 version of AS 3959; and
 - (iv) change the limitations on winders used in lieu of quarter and half landings within stairways; and
 - (v) include minor technical changes.

1.8 Amendment No. 8

- (a) Amendment No. 8 of the 1996 edition of the BCA was adopted as set out in Table 1.8.

Table 1.8 History of adoption of Amendment No. 8 of BCA96

Administration	Adoption Date
Australian Government	1 January 2001
Australian Capital Territory	11 January 2001
New South Wales	1 January 2001
Northern Territory	1 January 2001
Queensland	1 January 2001
South Australia	1 January 2001
Tasmania	1 January 2001
Victoria	1 January 2001
Western Australia	1 January 2001

- (b) The purpose of Amendment No. 8 is to—
- (i) update references to standards; and

- (ii) include minor technical changes; and
- (iii) achieve greater consistency between both Volumes of the BCA for stair construction.

1.9 Amendment No. 9

(a) Amendment No. 9 of the 1996 edition of the BCA was adopted as set out in Table 1.9.

Table 1.9 History of adoption of Amendment No. 9 of BCA96

Administration	Adoption Date
Australian Government	1 July 2001
Australian Capital Territory	12 July 2001
New South Wales	1 July 2001
Northern Territory	1 July 2001
Queensland	1 July 2001
South Australia	2 July 2001
Tasmania	1 July 2001
Victoria	1 July 2001
Western Australia	1 July 2001

- (b) The purpose of Amendment No. 9 is to—
- (i) update references to standards; and
 - (ii) include minor technical changes; and
 - (iii) clarify which glazing assemblies must comply with AS 2047 and which must comply with AS 1288.

1.10 Amendment No. 10

(a) Amendment No. 10 of the 1996 edition of the BCA was adopted as set out in Table 1.10.

Table 1.10 History of adoption of Amendment No. 10 of BCA96

Administration	Adoption Date
Australian Government	1 January 2002
Australian Capital Territory	1 January 2002
New South Wales	1 January 2002
Northern Territory	1 January 2002
Queensland	1 January 2002
South Australia	1 January 2002 (except SA2—date to be advised)
Tasmania	1 January 2002
Victoria	1 January 2002

Administration	Adoption Date
Western Australia	1 January 2002

- (b) The purpose of Amendment No. 10 is to—
- (i) update references to standards; and
 - (ii) update the requirements for protective coatings for steelwork in locations near saltwater; and
 - (iii) align **Figure 3.6.1** dealing with glazing with AS 1288; and
 - (iv) extend the concession for fire separation of windows in non-habitable rooms to windows in bathrooms, laundries and toilets and also include buildings on the same allotment; and
 - (v) replace testing to AS/NZS 1530.3 for timber in bushfire areas with reference to AS/NZS 3837; and
 - (vi) include minor technical changes.

1.11 Amendment No. 11

- (a) Amendment No. 11 of the 1996 edition of the BCA was adopted as set out in Table 1.11.

Table 1.11 History of adoption of Amendment No. 11 of BCA96

Administration	Adoption Date
Australian Government	1 July 2002
Australian Capital Territory	1 July 2002 (except Australian Capital Territory additions—which was adopted on 21 June 2002)
New South Wales	1 July 2002
Northern Territory	1 July 2002
Queensland	1 July 2002
South Australia	1 July 2002
Tasmania	1 July 2002
Victoria	1 July 2002
Western Australia	1 July 2002

- (b) The purpose of Amendment No. 11 is to—
- (i) update references to standards; and
 - (ii) transfer public policy matters, with respect to structural adequacy, from the AS 1170 series to the BCA; and
 - (iii) introduce new definitions and more detailed provisions on the installation of *flashings* and *damp-proof courses*; and
 - (iv) include minor technical changes.

1.12 Amendment No. 12

(a) Amendment No. 12 of the 1996 edition of the BCA was adopted as set out in Table 1.12.

Table 1.12 History of adoption of Amendment No. 12 of BCA96

Administration	Adoption Date
Australian Government	1 January 2003
Australian Capital Territory	1 January 2003
New South Wales	1 January 2003
Northern Territory	1 January 2003
Queensland	1 January 2003
South Australia	1 January 2003
Tasmania	1 January 2003
Victoria	1 January 2003
Western Australia	1 January 2003

- (b) The purpose of Amendment No. 12 is to—
- (i) update references to standards; and
 - (ii) allow the use of either the 1989 editions or the 2002 editions of the 1170 series of standards; and
 - (iii) include Energy Efficiency measures into the Housing Provisions; and
 - (iv) include minor technical changes.

Note:

Only substantive typographical corrections are noted in the margin.

1.13 Amendment No. 13

(a) Amendment No. 13 of the 1996 edition of the BCA was adopted as set out in Table 1.13.

Table 1.13 History of adoption of Amendment No. 13 of BCA96

Administration	Adoption Date
Australian Government	1 July 2003
Australian Capital Territory	1 July 2003
New South Wales	1 July 2003
Northern Territory	1 July 2003
Queensland	1 July 2003 (except for Parts 2.6 and 3.12 which are adopted on 1 September 2003)
South Australia	1 July 2003
Tasmania	1 July 2003

Administration	Adoption Date
Victoria	1 July 2003
Western Australia	1 July 2003

- (b) The purpose of Amendment No. 13 is to—
- (i) update references to standards; and
 - (ii) refine the Energy Efficiency provisions and advise of their adoption in Western Australia and Queensland; and
 - (iii) include minor technical changes.

Note:

Only substantive typographical corrections are noted in the margin.

2.0 Adoption of BCA 2004

- (a) The 2004 edition of the BCA was adopted as set out in Table 2.0.

Table 2.0 History of adoption of BCA 2004

Administration	Adoption Date
Australian Government	1 May 2004
Australian Capital Territory	1 May 2004
New South Wales	1 May 2004
Northern Territory	1 May 2004
Queensland	1 May 2004
South Australia	1 May 2004
Tasmania	1 May 2004
Victoria	1 May 2004
Western Australia	1 May 2004

- (b) The purpose of BCA 2004 is to—
- (i) remove references to BCA 96; and
 - (ii) clarify the method of determining the Performance Requirements that are relevant to Alternative Solutions; and
 - (iii) update references to other documents; and
 - (iv) revise the acceptable construction practice for footing and slab construction; and
 - (v) prohibit the use of lead on roofs used to collect potable water; and
 - (vi) reform the provisions for sound insulation; and
 - (vii) update the energy efficiency provisions; and
 - (viii) include minor technical changes.

LIST OF AMENDMENTS

SUPERSEDED
LIST OF AMENDMENTS

CONTENTS

LIST OF AMENDMENTS

List of Amendments Housing Provisions (Volume Two)

SUPERSEDED
LIST OF AMENDMENTS

LIST OF AMENDMENTS - HOUSING PROVISIONS

This list has been prepared by the Australian Building Codes Board to assist BCA users in identifying changes incorporated into the 2004 edition of the Housing Provisions (Volume Two) of the BCA (BCA 2004).

While the Australian Building Codes Board has attempted to include all changes from the previous edition of the BCA Housing Provisions, the Board does not give any warranty nor accept any liability in relation to the contents of this list of amendments.

BCA Reference	Changes & Commentary
Contents and features, introduction	
How to Use	This section has been removed because it is not relevant to the new format of the BCA.
Introduction	A number of editorial changes have been made as a consequence of the change to the 2004 edition of the BCA.
Part 1.0	
1.0.8(c)	New Subclause 1.0.8(c) inserted advising that the Performance Requirements relevant to an Alternative Solution are to be determined in accordance with the new Clause 1.0.10.
1.0.10	New Clause 1.0.10 inserted to clarify the method of determining all of the Performance Requirements that are relevant to an Alternative Solution. The new provisions clarify that, when developing an Alternative Solution, it is necessary to consider all of the Performance Requirements in Section 2.
Part 1.1	
Figure 1.1.4	A number of minor changes have been made to the climate zones in South Australia.
1.1.3	New Subclause 1.1.3(b) inserted regarding the applicability of secondary referenced documents. The existing provisions have become Subclause 1.1.3(a).
Part 1.4	
Part 1.4	The heading to Part 1.4 has been changed from "Standards adopted by reference" to "Documents adopted by reference" to reflect the fact that not all of the documents referenced in the BCA are "Standards".
Table 1.4.1	The following changes have been made to the list of referenced documents:
AS 2327.1	2003 edition of AS 2327 Composite structures, Part 1 Simply supported beams referenced.
AS/NZS 3500.3	2003 edition of AS/NZS 3500 Plumbing and drainage, Part 3 Stormwater drainage referenced.
AS/NZS 3500.4	2003 edition of AS/NZS 3500 Plumbing and drainage, Part 4 Heated water systems referenced.

SUPERSEDED
LIST OF AMENDMENTS

BCA Reference	Changes & Commentary
AS 3700	Amendment No. 2, December 2003 of AS 3700 Masonry structures referenced.
AS 3740	2004 edition of AS 3740 Waterproofing of wet areas within residential buildings referenced.
ABCB Protocol for House Energy Rating Software	2004.1 version of the ABCB Protocol for House Energy Rating Software added to Table 1.4.1 as a new referenced document.
SA referenced documents	2002 version of the South Australian Housing Code referenced in South Australia.
Vic referenced documents	Edition 3 of FirstRate house energy rating software referenced in Victoria. Version 2.32 of NatHERS (Nationwide House Energy Rating Software) referenced in Victoria. Practice Note 2004-55 Residential sustainability measures referenced in Victoria.
Tas referenced documents	2003 revised version of AS 1926 Swimming pool safety, Part 3 Water recirculation systems referenced in Tasmania.
Part 2.2	
O2.1	New provision inserted in Objective to include public policy matters for glazing into the BCA.
F2.1(b)	New sub-clause of Functional Statement inserted to include public policy matters for glazing into the BCA.
P2.1(d)	New sub-clause of Performance Requirement inserted to include public policy matters for glazing into the BCA.
P2.2.3 NSW Var.	Variation inserted that details a New South Wales Performance Requirement for barriers under slabs.
Part 2.4	
P2.4.6(a)	Reference to impact generated sound has been removed from Subclause 2.4.6(a).
P2.4.6(b)	New subclause inserted detailing the new performance requirements for the insulation of impact generated sound.
P2.4.6(c)	Existing Subclause 2.4.6(b) has been re-numbered Subclause 2.4.6(c).
P2.4.6 State and Territory var.	State and Territory variation inserted to enable the existing sound insulation Performance Requirement to be retained in the Northern Territory, Queensland and Western Australia.
V2.4.6	New Verification Method inserted that addresses the requirements of Subclauses P2.4.6(a) and P2.4.6(c).
V2.4.6 State and Territory var.	State and Territory variation inserted to reflect the fact that V2.4.6 has not been adopted in the Northern Territory, Queensland and Western Australia.

SUPERSEDED
LIST OF AMENDMENTS

BCA Reference	Changes & Commentary
Part 2.6	
Part 2.6 State and Territory var.	State and Territory variation updated to reflect the current status of Part 2.6 in the Australian Capital Territory, New South Wales and Victoria.
Part 2.6 State and Territory var. Expl. information	State and Territory variation deleted because it is no longer relevant.
V2.6 Expl. information	Explanatory information updated to include reference to the new ABCB Protocol for House Energy Rating Software.
V2.6.2.1(a)(i)(A)	ACB Protocol for House Energy Rating Software inserted into Subclause V2.6.2.1(a)(i)(A) as the means of determining the "house energy rating".
Table V2.6.2	Table heading changed from "Reference dwelling modelling requirements" to "Reference building modelling requirements" for consistency with the terminology used in Clause V2.6.2.2.
Part 3.1	
Part 3.1.1 Appropriate Performance Requirements	The existing provisions have been amended to include reference to the new Clause 1.0.10. Where an Alternative Solution to the provisions in Part 3.1.1 is proposed, the relevant Performance Requirements must be determined in accordance with the new Clause 1.0.10.
Part 3.1.1 NSW Var.	An editorial change has been made to the note in the New South Wales variation to Part 3.1.1.
Part 3.1.2 Appropriate Performance Requirements	The existing provisions have been amended to include reference to Clause 1.0.10. Where an Alternative Solution to the provisions in Part 3.1.2 is proposed, the relevant Performance Requirements must be determined in accordance with Clause 1.0.10.
3.1.3	Clause 3.1.3 heading changed from "Application" to "Application of this Part" to distinguish it from Clause 3.1.3.1.
Part 3.1.3 Appropriate Performance Requirements	The existing provisions have been amended to include reference to the new Clause 1.0.10. Where an Alternative Solution to the provisions in Part 3.1.3 is proposed, the relevant Performance Requirements must be determined in accordance with the new Clause 1.0.10.
Part 3.2	
Part 3.2 Appropriate Performance Requirements	The existing provisions have been amended to include reference to the new Clause 1.0.10. Where an Alternative Solution to the provisions in Part 3.2 is proposed, the relevant Performance Requirements must be determined in accordance with the new Clause 1.0.10.
3.2.0(a) NSW var.	New South Wales variation to Subclause 3.2.0(a) inserted.
3.2.1(b)	The limitation on slab length has been increased to 30 m for consistency with Amendment No. 3 to AS 2870.
3.2.2.1(e) NSW var.	New South Wales variation to Subclause 3.2.2.1(e) inserted.
3.2.2.6 NSW var.	New South Wales variation to Clause 3.2.2.6 inserted.

**SUPERSEDED
LIST OF AMENDMENTS**

BCA Reference	Changes & Commentary
3.2.3.2 Expl. information	Reinforcement nomenclature updated in accordance with Amendment No. 3 to AS 2870. Each paragraph has also been reworded for improved clarity.
Table 3.2.3.2	Reinforcement nomenclature and cross-sectional area updated in accordance with Amendment No. 3 to AS 2870. Notes have been inserted into Table 3.2.3.2 to achieve consistency with AS 2870.
3.2.5.3(a)	Clause 3.2.5.3(a) has been amended to achieve consistency with AS 2870.
3.2.5.3(b)	Reinforcement nomenclature updated in accordance with Amendment No. 3 to AS 2870.
3.2.5.4	For consistency with Amendment No. 3 to AS 2870, Clause 3.2.5.4 has been amended to allow the use of N10 ties. Editorial change made to clarify where an edge beam may be reduced to 150 mm in thickness.
3.2.5.5(a)	Reinforcement nomenclature updated in accordance with Amendment No. 3 to AS 2870.
Figure 3.2.5.3(a)	Reinforcement nomenclature updated in accordance with Amendment No. 3 to AS 2870. An additional column for slab mesh has also been inserted.
Figure 3.2.5.3(b)	Reinforcement nomenclature updated in accordance with Amendment No. 3 to AS 2870. An additional column for slab mesh has also been inserted.
Figure 3.2.5.4(a)	Reinforcement nomenclature updated in accordance with Amendment No. 3 to AS 2870.
Figure 3.2.5.4(b)	Reinforcement nomenclature updated in accordance with Amendment No. 3 to AS 2870.
Figure 3.2.5.5	Reinforcement nomenclature, terminology and the specified slab mesh updated in accordance with Amendment No. 3 to AS 2870.
Part 3.3	
Part 3.3.1 Appropriate Performance Requirements	The existing provisions have been amended to include reference to the new Clause 1.0.10. Where an Alternative Solution to the provisions in Part 3.3.1 is proposed, the relevant Performance Requirements must be determined in accordance with the new Clause 1.0.10.
Part 3.3.2 Appropriate Performance Requirements	The existing provisions have been amended to include reference to the new Clause 1.0.10. Where an Alternative Solution to the provisions in Part 3.3.2 is proposed, the relevant Performance Requirements must be determined in accordance with the new Clause 1.0.10.
Part 3.3.3 Appropriate Performance Requirements	The existing provisions have been amended to include reference to the new Clause 1.0.10. Where an Alternative Solution to the provisions in Part 3.3.3 is proposed, the relevant Performance Requirements must be determined in accordance with the new Clause 1.0.10.

**SUPERSEDED
LIST OF AMENDMENTS**

BCA Reference	Changes & Commentary
Part 3.3.4 Appropriate Performance Requirements	The existing provisions have been amended to include reference to the new Clause 1.0.10. Where an Alternative Solution to the provisions in Part 3.3.4 is proposed, the relevant Performance Requirements must be determined in accordance with the new Clause 1.0.10.
3.3.4.3	Clause 3.3.4.3 has been reworded to allow the deletion of weepholes in masonry veneer or cavity walls that are adequately weatherproofed.
Figure 3.3.4.1	Figure 3.3.4.1 has been updated to include weatherproofed masonry veneer.
3.3.4.6(c)	A new Subclause 3.3.4.6(c) has been inserted to prohibit, for health reasons, the use of lead flashings on roofs used to collect potable water.
3.3.4.7(d)	Subclause 3.3.4.7(d) amended to allow an exemption from the need for flashing where an external wall has been adequately waterproofed.
3.3.4.12 Limitation	Correction made to the clause number referenced in the limitation.
Part 3.3.5 Appropriate Performance Requirements	The existing provisions have been amended to include reference to the new Clause 1.0.10. Where an Alternative Solution to the provisions in Part 3.3.5 is proposed, the relevant Performance Requirements must be determined in accordance with the new Clause 1.0.10.
Part 3.4	
Part 3.4.1 Appropriate Performance Requirements	The existing provisions have been amended to include reference to the new Clause 1.0.10. Where an Alternative Solution to the provisions in Part 3.4.1 is proposed, the relevant Performance Requirements must be determined in accordance with the new Clause 1.0.10.
Figure 3.4.1	Typographical correction made to the heading on the second page of the figure.
Part 3.4.2 Appropriate Performance Requirements	The existing provisions have been amended to include reference to the new Clause 1.0.10. Where an Alternative Solution to the provisions in Part 3.4.2 is proposed, the relevant Performance Requirements must be determined in accordance with the new Clause 1.0.10.
Part 3.4.3 Appropriate Performance Requirements	The existing provisions have been amended to include reference to the new Clause 1.0.10. Where an Alternative Solution to the provisions in Part 3.4.3 is proposed, the relevant Performance Requirements must be determined in accordance with the new Clause 1.0.10.
Part 3.4.4 Appropriate Performance Requirements	The existing provisions have been amended to include reference to the new Clause 1.0.10. Where an Alternative Solution to the provisions in Part 3.4.4 is proposed, the relevant Performance Requirements must be determined in accordance with the new Clause 1.0.10.
Part 3.5	
Part 3.5.1 Appropriate Performance Requirements	The existing provisions have been amended to include reference to the new Clause 1.0.10. Where an Alternative Solution to the provisions in Part 3.5.1 is proposed, the relevant Performance Requirements must be determined in accordance with the new Clause 1.0.10.
3.5.1.2(e)	A new subclause has been inserted to prohibit, for health reasons, the use of lead flashings on roofs used to collect potable water..

**SUPERSEDED
LIST OF AMENDMENTS**

BCA Reference	Changes & Commentary
Figure 3.5.1.1	The diagram and table in Figure 3.5.1.1 have been updated for consistency with the revised version of AS 2050.
Part 3.5.2 Appropriate Performance Requirements	The existing provisions have been amended to include reference to the new Clause 1.0.10. Where an Alternative Solution to the provisions in Part 3.5.2 is proposed, the relevant Performance Requirements must be determined in accordance with the new Clause 1.0.10.
3.5.2.2	Clause 3.5.2.2 has been amended to prohibit, for health reasons, the use of lead in gutters, downpipes and flashings forming part of a roof that collects potable water.
Part 3.5.3 Appropriate Performance Requirements	The existing provisions have been amended to include reference to the new Clause 1.0.10. Where an Alternative Solution to the provisions in Part 3.5.3 is proposed, the relevant Performance Requirements must be determined in accordance with the new Clause 1.0.10.
Part 3.6	
Part 3.6 Appropriate Performance Requirements	The existing provisions have been amended to include reference to the new Clause 1.0.10. Where an Alternative Solution to the provisions in Part 3.6 is proposed, the relevant Performance Requirements must be determined in accordance with the new Clause 1.0.10.
Part 3.7	
Part 3.7.1 Appropriate Performance Requirements	The existing provisions have been amended to include reference to the new Clause 1.0.10. Where an Alternative Solution to the provisions in Part 3.7.1 is proposed, the relevant Performance Requirements must be determined in accordance with the new Clause 1.0.10.
3.7.1.7(b)	Amended to include rainwater tanks as an allowable encroachment within 900 mm of an allotment boundary or within 1.8 m of another building on the same allotment. Water conservation is an important issue in all States and Territories. The amendment is intended to facilitate the installation of rainwater tanks in urban and rural areas.
Part 3.7.2 Appropriate Performance Requirements	The existing provisions have been amended to include reference to the new Clause 1.0.10. Where an Alternative Solution to the provisions in Part 3.7.2 is proposed, the relevant Performance Requirements must be determined in accordance with the new Clause 1.0.10.
Part 3.7.3 Appropriate Performance Requirements	The existing provisions have been amended to include reference to the new Clause 1.0.10. Where an Alternative Solution to the provisions in Part 3.7.3 is proposed, the relevant Performance Requirements must be determined in accordance with the new Clause 1.0.10.
Part 3.7.4 Appropriate Performance Requirements	The existing provisions have been amended to include reference to the new Clause 1.0.10. Where an Alternative Solution to the provisions in Part 3.7.4 is proposed, the relevant Performance Requirements must be determined in accordance with the new Clause 1.0.10.
3.7.4.0 SA var.	South Australia variation to Clause 3.7.4.0 amended.
3.7.4.1 SA var.	South Australia variation to Clause 3.7.4.0 amended.

**SUPERSEDED
LIST OF AMENDMENTS**

BCA Reference	Changes & Commentary
Table 3.7.4.1	Under the heading of “Verandahs and Decks” in the medium bushfire attack category, paragraph (e)(ii) has been amended to clarify the intent and for consistency with AS 3959.
Part 3.7.5 Appropriate Performance Requirements	The existing provisions have been amended to include reference to the new Clause 1.0.10. Where an Alternative Solution to the provisions in Part 3.7.5 is proposed, the relevant Performance Requirements must be determined in accordance with the new Clause 1.0.10.
Part 3.8	
Part 3.8.1 Appropriate Performance Requirements	The existing provisions have been amended to include reference to the new Clause 1.0.10. Where an Alternative Solution to the provisions in Part 3.8.1 is proposed, the relevant Performance Requirements must be determined in accordance with the new Clause 1.0.10.
3.8.1 Definitions	The definitions have been removed from Part 3.8.1 Wet Areas. These provisions have been superseded by AS 3740 which remains as the Acceptable Construction Manual.
3.8.1.0 SA var.	South Australia variation to Clause 3.8.1.0 amended to include reference to AS 3740.
Part 3.8.1 Accept. Construction Practice	The Acceptable Construction Practice has been removed from Part 3.8.1 Wet Areas. These provisions have been superseded by AS 3740 which remains as the Acceptable Construction Manual.
Part 3.8.2 Appropriate Performance Requirements	The existing provisions have been amended to include reference to the new Clause 1.0.10. Where an Alternative Solution to the provisions in Part 3.8.2 is proposed, the relevant Performance Requirements must be determined in accordance with the new Clause 1.0.10.
Part 3.8.3 Appropriate Performance Requirements	The existing provisions have been amended to include reference to the new Clause 1.0.10. Where an Alternative Solution to the provisions in Part 3.8.3 is proposed, the relevant Performance Requirements must be determined in accordance with the new Clause 1.0.10.
Part 3.8.4 Appropriate Performance Requirements	The existing provisions have been amended to include reference to the new Clause 1.0.10. Where an Alternative Solution to the provisions in Part 3.8.4 is proposed, the relevant Performance Requirements must be determined in accordance with the new Clause 1.0.10.
Part 3.8.5 Appropriate Performance Requirements	The existing provisions have been amended to include reference to the new Clause 1.0.10. Where an Alternative Solution to the provisions in Part 3.8.5 is proposed, the relevant Performance Requirements must be determined in accordance with the new Clause 1.0.10.
Part 3.8.5 Expl. information	Correction made to the second sentence with respect to those States and Territories to which Part 3.12 does not apply.
Part 3.8.6 Appropriate Performance Requirements	The existing provisions have been amended to include reference to the new Clause 1.0.10. Where an Alternative Solution to the provisions in Part 3.8.6 is proposed, the relevant Performance Requirements must be determined in accordance with the new Clause 1.0.10.

SUPERSEDED
LIST OF AMENDMENTS

BCA Reference	Changes & Commentary
3.8.6.2	The requirements for walls separating buildings have been changed to include weighted sound reduction index with spectrum adaptation term, for airborne sound, and discontinuous construction requirements, for impact sound.
Table 3.8.6.1	Table 3.8.6.1 has been amended to include weighted sound reduction index with spectrum adaptation term, for airborne sound, and discontinuous construction requirements, for impact sound. Note inserted into table to clarify what is meant by the term “discontinuous construction”.
Figure 3.8.6.1	Figure 3.8.6.1 has been amended to include weighted sound reduction index with spectrum adaptation term, for airborne sound, and discontinuous construction requirements, for impact sound.
3.8.6.3(a)	The wording of Subclause 3.8.6.3(a) has been simplified from “achieve the appropriate R_w and impact sound resistance” to “achieve the appropriate level of sound insulation”. Minor grammatical change made to 3.8.6.3(a)(i). Minor grammatical change made to 3.8.6.3(a)(ii).
Figure 3.8.6.2	The existing Figure 3.8.6.3 has been re-numbered Figure 3.8.6.2 and moved to underneath subclause 3.8.6.3(a). Minor change made to heading of Figure 3.8.6.2.
3.8.6.3(b)	Subclause 3.8.6.3(b) has been modified to include articulation joints in the general insulation requirements and to remove reference to chasing, which is now covered by 3.8.6.4.
3.8.6.3(c)	Subclause 3.8.6.3(c) has been reworded for improved clarity.
3.8.6.3(d)	References to Figure 3.8.6.3 have been inserted into subclause 3.8.6.3(d).
3.8.6.3(e)	The application of Subclause 3.8.6.3(e) has been amended from “steel studs and perimeter members” to “steel framing”.
3.8.6.3(f)	The lead-in to Subclause 3.8.6.3(f) has been amended from “timber studs and perimeter members” to “timber framing”.
3.8.6.4	The clause heading has been changed from “Soil and waste pipes” to “Services”. Subclauses 3.8.6.4(a) inserted to provide the general requirements for the installation of services in separating walls. Subclause 3.8.6.4(b) inserted to provide the requirements for duct, soil waste, water supply and storm water pipes that pass through a separating wall or are located in a separating wall. Subclause 3.8.6.4(c) inserted to provide the requirements for electrical outlets.
Table 3.8.6.2	New Table inserted giving construction details to meet the levels of R_w + Ctr required by Part 3.8.6.
Table 3.8.6.2 Expl. information	Explanatory information box amended as a consequence of the changes to the sound insulation provisions.

**SUPERSEDED
LIST OF AMENDMENTS**

BCA Reference	Changes & Commentary
Part 3.8.6 State and Territory Var.	State and Territory variation inserted to enable the existing sound insulation provisions to be retained in the Northern Territory, Queensland and Western Australia.
Part 3.9	
Part 3.9.1 Appropriate Performance Requirements	The existing provisions have been amended to include reference to the new Clause 1.0.10. Where an Alternative Solution to the provisions in Part 3.9.1 is proposed, the relevant Performance Requirements must be determined in accordance with the new Clause 1.0.10.
3.9.1.5	New Clause 3.9.1.5 has been inserted to specify the maximum height of a threshold before it is required to incorporate a step.
Part 3.9.2 Appropriate Performance Requirements	The existing provisions have been amended to include reference to Clause 1.0.10. Where an Alternative Solution to the provisions in Part 3.9.2 is proposed, the relevant Performance Requirements must be determined in accordance with Clause 1.0.10.
Part 3.9.3 Appropriate Performance Requirements	The existing provisions have been amended to include reference to the new Clause 1.0.10. Where an Alternative Solution to the provisions in Part 3.9.3 is proposed, the relevant Performance Requirements must be determined in accordance with the new Clause 1.0.10.
Part 3.10	
Part 3.10.1 Appropriate Performance Requirements	The existing provisions have been amended to include reference to the new Clause 1.0.10. Where an Alternative Solution to the provisions in Part 3.10.1 is proposed, the relevant Performance Requirements must be determined in accordance with the new Clause 1.0.10.
3.10.1.0	The term “high wind area” has been italicized because it is a defined term.
Part 3.10.2 Appropriate Performance Requirements	The existing provisions have been amended to include reference to the new Clause 1.0.10. Where an Alternative Solution to the provisions in Part 3.10.2 is proposed, the relevant Performance Requirements must be determined in accordance with the new Clause 1.0.10.
Part 3.11	
Part 3.11 Expl. information	Typographical correction made to include Part 3.12 in the list of Deemed-to-Satisfy Provisions that may be used in conjunction with Part 11.
Part 3.11 Appropriate Performance Requirements	The existing provisions have been amended to include reference to the new Clause 1.0.10. Where an Alternative Solution to the provisions in Part 3.11 is proposed, the relevant Performance Requirements must be determined in accordance with the new Clause 1.0.10.
Part 3.12	
Part 3.12 Appropriate Performance Requirements	The existing provisions have been amended to include reference to the new Clause 1.0.10. Where an Alternative Solution to the provisions in Part 3.12 is proposed, the relevant Performance Requirements must be determined in accordance with the new Clause 1.0.10.

**SUPERSEDED
LIST OF AMENDMENTS**

BCA Reference	Changes & Commentary
Part 3.12 State and Territory var.	State and Territory variation updated to reflect the current status of Part 3.12 in the Australian Capital Territory, New South Wales and Victoria.
3.12 Expl. information	Explanatory information deleted because it is no longer relevant.
3.12 Definition	The term “RBM” has been changed to “reflective insulation” for consistency with AS/NZS 4859.1. The definition has also been amended in acknowledgment that AS/NZS 4859.1 allows different values for reflectance and emittance.
3.12 Expl. information	New Explanatory information inserted to advise BCA users where they may obtain information about R-Values of reflective insulation and to explain the relationship between emittance and reflectance.
3.12.1.1	<p>The following changes have been made to Clause 3.12.1.1:</p> <ul style="list-style-type: none"> • The word ‘thermal’ has been included in the heading to clarify the type of insulation it applies to. • “Where <i>required</i>” included in subclause (a) to clarify that it only applies to insulation required by provisions of the BCA. • Subclause 3.12.1.1(a) has been updated so that it refers to the referenced standards in subclause 3.12.1.1(d) and incorporates the general installation requirements previously contained in Subclause 3.12.1.1(c)(iii). • The term “RBM” has been changed to “reflective insulation” for consistency with AS/NZS 4859.1. • Subclause 3.12.1.1(b) has been updated so that it refers to the referenced standards in subclause 3.12.1.1(d). • Subclause 3.12.1.1(c)(iii) has been deleted because its provisions have been incorporated into Subclause 3.12.1.1(a).
3.12.1.1 Expl. information	<p>The term “RBM” has been changed to “reflective insulation” for consistency with AS/NZS 4859.1.</p> <p>New Explanatory information point 1 inserted to advise BCA users that the performance of reflective insulation is related to the amount of adjoining airspace provided.</p> <p>Point 4 has been amended to provide advice on the likely date that the superseded standards will be removed from the BCA.</p>
3.12.1.2(b)	The term “RBM” has been changed to “reflective insulation” for consistency with AS/NZS 4859.1. The required level of emittance of the reflective insulation has been specified in Subclause 3.12.1.2(b).
Table 3.12.1.1	The order of the rows in Table 3.12.1.1 has been changed for consistency with changes made to Figure 3.12.1.1.
Table 3.12.1.1 Expl. information	The term “RBM” has been changed to “reflective insulation” for consistency with AS/NZS 4859.1.

SUPERSEDED
LIST OF AMENDMENTS

BCA Reference	Changes & Commentary
Figure 3.12.1.1	<p>Formatting of Figure 3.12.1.1 has changed to clarify the applicability of the direction of heat flow.</p> <p>Note 4 inserted to clarify how the values in Figure 3.12.1.1(c) were calculated.</p>
Figure 3.12.1.1 Expl. information	<p>The term “RBM” has been changed to “reflective insulation” for consistency with AS/NZS 4859.1.</p> <p>Point 1 has had an additional sentence included to describe how the Total R-Value has been calculated.</p> <p>Additional sentence inserted into point 3 to explain that insulation installed underneath a roof is less effective than insulation installed above a ceiling.</p> <p>Point 4 has been amended to provide more information about reflective insulation.</p>
3.12.1.3(a)(ii)(B)	<p>The words “including any imperforate ceiling diffuser” inserted into 3.12.1.3(a)(ii)(B) to clarify the application of the subclause.</p>
Table 3.12.1.2	<p>The word “vertical” has been removed from Note 1 in acknowledgement that the shaft of a roof light may not be vertical.</p> <p>Additional Note 5 inserted in acknowledgement that an imperforate ceiling diffuser may contribute to the Total U-Value of a ceiling light.</p>
Figure 3.12.1.3	<p>The value for the minimum added R-Value of insulation in the cell corresponding to autoclaved aerated concrete masonry in climate zone 7 has been changed from “Nil” to “0.17” to indicate exactly how much added R-Value of insulation is required rather than rounding it down to “Nil”.</p> <p>Reference to “timber” in the first column of Figure 3.12.1.3 has been deleted to allow the use of either timber or steel framed wall construction.</p>
Figure 3.12.1.3 QLD var.	<p>Reference to “timber” in the first column of Figure 3.12.1.3 has been deleted to allow the use of either timber or steel framed wall construction.</p>
Figure 3.12.1.3 Expl. information	<p>The term “RBM” has been changed to “reflective insulation” for consistency with AS/NZS 4859.1.</p> <p>Point 1 has been amended to clarify the basis on which the total R-Values in Figure 3.12.1.3 have been calculated.</p> <p>Point 2 has been amended to include reference to the standards prescribed in 3.12.1.1(d) and to clarify the information provided about the use of reflective insulation.</p> <p>Point 5 has been deleted.</p> <p>Existing point 6 has been amended to avoid the repetition of information and re-numbered as point 5</p> <p>Existing point 7 has been amended so as not to refer specifically to timber framing and re-numbered as point 6.</p>

**SUPERSEDED
LIST OF AMENDMENTS**

BCA Reference	Changes & Commentary
Figure 3.12.1.4 Expl. information	The term "RBM" has been changed to "reflective insulation" for consistency with AS/NZS 4859.1. Point 3 has been amended to clarify the level of performance that may be achieved by different types of insulation underneath a suspended floor. Point 5 amended to avoid the repetition of information.
3.12.2.1	New Subclause 3.12.2.1(b)(iii) inserted to allow the combination of different glazing types and shading projections.
3.12.2.1 Expl. information	New Explanatory information inserted to provide practical guidance on the application and use of Subclause 3.12.2.1(b)(iii)(B).
Figure 3.12.2.2	Diagram updated to clarify examples of shading projections.
Table 3.12.2.1	Note 8 rewritten to clarify how the figures in the Table 3.12.2.1 may be adjusted for different height windows.
3.12.4.1(a)(i)	Subclause 3.12.4.1(a)(i) has been amended to account for the use of evaporative coolers in climate zones 3 and 4.
3.12.4.1(a) Expl. information	The explanatory information to Subclause 3.12.4.1(a) has been amended to provide advice on the effectiveness of evaporative coolers.
Table 3.12.4.1	Table 3.12.4.1 has been amended to account for the use of evaporative coolers in climate zones 3 and 4.
3.12.4.1 and Table 3.12.4.1 WA var.	Western Australia variation to Clause 3.12.4.1 and Table 3.12.4.1 inserted for the following reasons: <ul style="list-style-type: none"> • The new provisions that account for evaporative coolers have not been adopted in Western Australia. • A new Subclause 3.12.4.1(a)(iii) has been inserted to provide a concession for buildings located within Region D 'Severe Tropical Cyclones' (as designated in AS 1170.2 and AS/NZS 1170.2) in climate zone 1.
3.12.4.3	Clause 3.12.4.3 amended to include evaporative coolers in the ceiling fan requirements.
3.12.5.0(a)	Subclause 3.12.5.0(a) has been amended to refer to the correct section of the revised version of AS/NZS 3500.
New South Wales Additions	
NSW 2	NSW 2 - Energy Efficiency provisions have been inserted into the New South Wales Additions.
South Australia Additions	
SA 3.2.1	SA 3.2.1 has been amended to include reference to AS 3740.
SA 4.2.1	SA 4.2.1 has been amended to include reference to SA 4.2.3.
SA 4.2.3	New Clause 4.2.3 has been inserted regarding the installation of a "Warning Notice" on certain swimming pool shut-off valves.
SA 5 limitation	The limitation to SA 5 has been reworded.

SUPERSEDED
LIST OF AMENDMENTS

BCA Reference	Changes & Commentary
SA 5.2.2	Clause SA 5.2.2 has been reworded.
Victoria Additions	
VIC 1.1	The energy efficiency performance provisions in VIC 1.1 have been deleted because P2.6.1 has now been adopted in Victoria.
Vic 1.2.1	Clause Vic 1.2.1 has been modified to include reference to Performance Requirement P2.6.1.
Vic 1.2.3	The insulation provisions previously contained in Clause Vic 1.2.3 have been replaced with general energy efficiency requirements that are applicable in Victoria.
History of BCA Adoption	
Section Title	The Section title has been amended to "History of BCA Adoption" due to the Section including adoption dates for the various amendments to the 1996 edition of the BCA and as well as the adoption date for the 2004 edition of the BCA.
1.0 to 1.13	Reference to the "Commonwealth" in both the text and the Tables has been amended to "Australian Government" in line with Australian Government policy.
2.0	Clause 2.0 and Table 2.0 have been added in order to detail the adoption dates of the 2004 edition of the BCA in each State and Territory and to summarise the purposes of the changes from BCA96.