

SUPERSEDED

Building Code of Australia

Volume Two

Class 1 and Class 10 Buildings Housing Provisions

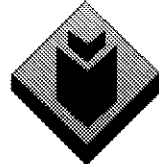

ABCB

Australian Building Codes Board

SUPERSEDED

© 1996 Commonwealth and States and Territories of Australia

The Building Code of Australia is the copyright of the Commonwealth and the States and Territories of Australia and, apart from any use as permitted under the Copyright Act 1968, no part may be reproduced without prior permission. Requests and enquiries concerning reproduction and rights should be directed in the first instance to the Executive Director, Australian Building Codes Board, GPO Box 9839 Canberra ACT 2601.

Australian Building Codes Board

GPO Box 9839 Canberra, ACT 2601

Telephone: Canberra (06) 213 7191 Facsimile: (06) 213 7287

The Australian Building Codes Board (ABCB) is established by agreement between the Commonwealth Government and each State and Territory Government. It is a co-operative arrangement between the signatories, Local Government and the building industry.

Standards Australia

PO Box 1055 Strathfield NSW 2135

Telephone: (02) 9746 4700 Facsimile: (02) 9746 8450

Standards Australia Important Disclaimer

Standards Australia does not accept any responsibility for the content of the *Building Code of Australia*. The *Building Code of Australia* has been published as provided by the Australian Building Codes Board.

CONTENTS AND FEATURES • INTRODUCTION

GENERAL TABLE OF CONTENTS

	Page
CONTENTS AND FEATURES	
How to Use	51
Introduction	101
1 The Building Code of Australia	
2 The Australian Building Codes Board	
3 The BCA - Content	
4 Legislative arrangements	
5 Documentation of decisions	
6 Structure	
7 Further development of the BCA	
8 Comments	
SECTION 1 - GENERAL	
1.0 Application	2,015
1.0.1 Adoption	
1.0.2 BCA Volumes	
1.0.3 BCA Structure	
1.0.4 Compliance with the BCA	
1.0.5 Meeting the Performance Requirement	
1.0.6 Objectives and Functional Statements	
1.0.7 Deemed-to-Satisfy Provisions	
1.0.8 Alternative Solutions	
1.0.9 Assessment Methods	
1.1 Interpretation	2,021
1.1.1 Definitions	
1.1.2 Adoption of referenced documents	
1.1.3 Context of reference	
1.1.4 Differences between referenced documents and the Housing Provisions	
1.1.5 Compliance with all Sections of the Housing Provisions	
1.1.6 Application of the Housing Provisions to a particular State or Territory	
1.1.7 Language	
1.1.8 Interpretation of diagrams	
1.1.9 Explanatory information	
Continued.	

	Page
Continued	
1.2 Acceptance of design and construction	2,201
1.2.1 Suitability of materials	
1.2.2 Evidence of suitability	
1.2.3 Fire resistance of building elements	
1.2.4 Early fire hazard indices	
1.3 Classification	2,401
1.3.1 Principles of classification	
1.3.2 Classification	
1.3.3 Multiple classifications	
1.4 Standards adopted by reference	2,601
1.4.1 Schedule of referenced documents	
SECTION 2 - PERFORMANCE PROVISIONS	
2.0 Application	3,021
2.1 Structure	3,031
2.2 Damp and weatherproofing	3,201
P2.2.1 Surface water	
P2.2.2 Weatherproofing	
P2.2.3 Dampness	
P2.2.4 Drainage from swimming pools	
2.3 Fire safety	3,401
P2.3.1 Protection from the spread of fire	
P2.3.2 Fire detection and early warning	
P2.3.3 Heating appliances	
P2.3.4 Bushfire areas	
P2.3.5 Alpine areas	
2.4 Health and amenity	3,601
P2.4.1 Wet areas	
P2.4.2 Room heights	
P2.4.3 Facilities	
P2.4.4 Light	
P2.4.5 Ventilation	
P2.4.6 Sound insulation	
Continued.	

Continued	Page
2.5 Safe movement and access	3,801
P2.5.1 Stairways and ramps	
P2.5.2 Barriers	
P2.5.3 Swimming pools access	
 SECTION 3 - ACCEPTABLE CONSTRUCTION	
How to Use	4,031
Introduction	
The scope of these provisions	
Suitability of Alternative Solutions	
The use of maps	
Consultation with appropriate authorities	
Layout of Parts 3.1 - 3.11	
How to use the requirements of each Part	
3.1 Site preparation	
3.1.1 Earthworks	5,021
3.1.1.0 Application	
3.1.1.1 Earthworks	
3.1.1.2 Excavation adjacent to vacant adjoining property	
3.1.1.3 Excavation adjacent to existing buildings	
3.1.1.4 Fill	
3.1.2 Drainage	5,201
3.1.2.0 Acceptable construction manual	
3.1.2.1 Application	
3.1.2.2 Drainage requirements	
3.1.2.3 Surface water drainage	
3.1.2.4 Subsoil drainage	
3.1.2.5 Stormwater drainage	
3.1.3 Termite risk management	5,801
3.1.3.0 Definitions	
3.1.3.1 Application of this Part	
3.1.3.2 Acceptable construction manual	
3.1.3.3 Application	
3.1.3.4 Installation of termite barriers	
3.1.3.5 Barriers for concrete slab-on-ground	
3.1.3.6 Protection of suspended floors	
Continued	

Amdt 3

Continued	Page
3.2 Footings and slabs	7,021
3.2 Definitions	
3.2.0 Acceptable construction manuals	
3.2.1 Application	
3.2.2 Preparation	7,201
3.2.2.1 Excavation for footings	
3.2.2.2 Filling under concrete slabs	
3.2.2.3 Foundations for footings and slabs	
3.2.2.4 Slab edge support on sloping sites	
3.2.3.5 Stepped footings	
3.2.2.6 Vapour barriers	
3.2.2.7 Edge rebates	
3.2.3 Concrete and reinforcing	7,401
3.2.3.1 Concrete	
3.2.3.2 Steel reinforcement	
3.2.4 Site classification	7,601
3.2.4.1 Site classification	
3.2.5 Footing and slab construction	7,801
3.2.5.1 Footing and slab construction	
3.2.5.2 Footings and slabs to extensions to existing buildings	
3.2.5.3 Shrinkage control	
3.2.5.4 Minimum edge beam dimensions	
3.2.5.5 Footings for fireplaces on Class A and S sites	
3.2.5.6. Stump footing details	
3.3 Masonry	
3.3 Definitions	9,012
3.3.1 Unreinforced masonry	9,021
3.3.1.0 Acceptable construction manual	
3.3.1.1 Application	
3.3.1.2 External walls	
3.3.1.3 Internal walls	
3.3.1.4 Isolated piers	
3.3.1.5 Masonry units	
3.3.1.6 Mortar mixes	
Continued.	

Amdt 3

Continued	Page
3.3.1.7 Mortar joints	
3.3.1.8 Vertical articulation joints	
3.3.1.9 Sub-floor ventilation	
3.3.1.10 Shrinkage allowance for timber framing	
3.3.2 Reinforced masonry	9,301
3.3.2.0 Acceptable construction manual	
3.3.2.1 Application	
3.3.2.2 External wall construction	
3.3.3 Masonry accessories	9,601
3.3.3.0 Acceptable construction manual	
3.3.3.1 Application	
3.3.3.2 Wall ties	
3.3.3.3 Fixing straps and tie down systems	
3.3.3.4 Lintels	
3.3.4 Weatherproofing	9,801
3.3.4 Definitions	
3.3.4.0 Acceptable construction manual	
3.3.4.1 Application	
3.3.4.2 Width of cavity	
3.3.4.3 Cavity ventilation and drainage	
3.3.4.4 Damp proof courses - materials	
3.3.4.5 Damp proof courses - installation	
3.3.4.6 Flashings	
3.3.4.7 Weatherproofing for single skin masonry walls	
3.3.5 Earthwall construction	10,101
3.3.5 Definitions	
3.3.5.0 Acceptable construction manual	
3.3.5.1 Application	
3.3.5.2 General construction	
3.3.5.3 Minimum thickness of walls	
3.3.5.4 Weatherproofing	
3.4. Framing	
3.4.0 Explanation of terms	11,051
3.4.1 Sub-floor ventilation	11,101
3.4.1.1 Application	
3.4.1.2 Sub-floor ventilation	
Continued.	

Amdt 3

	Page
Continued	
3.4.2. Steel framing	11,301
3.4.2.0 Acceptable construction manuals	
3.4.2.1 Application	
3.4.2.2 General	
3.4.2.3 Steel floor framing	
3.4.2.4 Steel wall framing	
3.4.2.5 Steel roof framing	
3.4.2.6 Installation of services	
3.4.3 Timber framing	
3.4.3.0 Acceptable construction manuals	11,601
3.4.3.1 Application	
3.4.3.2 Materials	
3.4.3.3 Floor framing	
3.4.3.4 Flooring	
3.4.3.5 Wall framing	
3.4.3.6 Conventional roofs	
3.4.3.7 Acceptable timber frame sizes and fixing	
3.4.3.8 Bracing of timber frames	
3.4.4 Structural steel members	12,201
3.4.4 Explanation of terms	
3.4.4.0 Acceptable construction manuals	
3.4.4.1 Application	
3.4.4.2 Structural steel members	
3.4.4.3 Columns	
3.4.4.4 Corrosion protection	
3.5 Roof and wall cladding	
3.5.1 Roof cladding	13,021
3.5.1.0 Acceptable construction manuals	
3.5.1.1 Application	
3.5.1.2 Roof tiling	
3.5.1.3 Metal sheet roofing	
3.5.2 Gutters and downpipes	13,301
3.5.2.0 Acceptable construction manuals	
3.5.2.1 Application	
3.5.2.2 Materials	
Continued.	

	Page
Continued	
3.5.2.3 Selection of guttering	
3.5.2.4 Installation of gutters	
3.5.2.5 Downpipes - size and installation	
3.5.3 Wall cladding	13,501
3.5.3.1 Application	
3.5.3.2 Timber weatherboard cladding	
3.5.3.3 Fibre cement planks and weatherboard cladding	
3.5.3.4 Sheet wall cladding	
3.5.3.5 Eaves and soffit linings	
3.5.3.6 Flashings to wall openings	
3.6. Glazing	15,021
3.6 Definitions	
3.6.0 Acceptable construction manual	
3.6.1 Application	
3.6.2 Glazing sizes and installation	
3.6.3 Perimeter framed glazing	
3.6.4 Human impact safety requirements	
3.6.5 Doors	
3.6.6 Side panels	
3.6.7 Full height framed glazed panels	
3.6.8 Glazed panels, other than doors or side panels, on the perimeter of rooms	
3.6.9 Shower doors, shower screens and bath enclosures	
3.7 Fire safety	
3.7.1 Fire separation	17,021
3.7.1.1 Application	
3.7.1.2 General concession - non combustible materials	
3.7.1.3 External walls of Class 1 buildings	
3.7.1.4 Measurement of distances	
3.7.1.5 Construction of external walls	
3.7.1.6 Class 10a buildings	
3.7.1.7 Allowable encroachments	
3.7.1.8 Separating walls	
3.7.1.9 Sarking type materials	
3.7.1.10 Roof lights	
	Continued.

	Page
Continued	
3.7.2 Smoke alarms	17,301
3.7.2.1 Application	
3.7.2.2 Requirements for smoke alarms	
3.7.2.3 Location - Class 1a buildings	
3.7.2.4 Location - Class 1b buildings	
3.7.2.5 Lighting to assist evacuation – Class 1b buildings	
Explanatory information - Smoke alarms	
3.7.3 Heating appliances	17,501
3.7.3.0 Acceptable construction manuals	
3.7.3.1 Application	
3.7.3.2 Open fireplace construction	
3.7.3.3 Chimney construction	
3.7.3.4 Installation of insert fireplaces and flues	
3.7.3.5 Installation of free standing heating appliances	
3.7.4 Bushfire areas	17,701
3.7.4.0 Acceptable construction manuals	
3.7.4.1 Application	
3.7.4.2 Bushfire protection	
3.7.5 Alpine areas	17,901
3.7.5.1 Application	
3.7.5.2 External doorways	
3.7.5.3 External ramps	
3.7.5.4 Discharge of external doorways providing means of egress	
3.7.5.5 External trafficable structures	
3.8 Health and amenity	
3.8.1 Wet areas	19,021
3.8.1 Definitions	
3.8.1.0 Acceptable construction manual	
3.8.1.1 Application	
3.8.1.2 Wet areas	
3.8.1.3 Materials - general	
3.8.1.4 Protection of shower floors in wet areas	
3.8.1.5 Protection of walls in wet areas	
3.8.1.6 Sealing of wall and floor junctions and joints	
	Continued.

	Page
Continued	
3.8.2 Room heights	19,301
3.8.2.1 Application	
3.8.2.2 Ceiling heights	
3.8.3 Facilities	19,501
3.8.3.1 Application	
3.8.3.2 Required facilities	
3.8.3.3 Construction of sanitary compartments	
3.8.4 Light	19,701
3.8.4.1 Application	
3.8.4.2 Natural lighting	
3.8.4.3 Artificial lighting	
3.8.5 Ventilation	19,901
3.8.5.0 Acceptable construction manual	
3.8.5.1 Application	
3.8.5.2 Ventilation requirements	
3.8.5.3 Location of sanitary compartments	
3.8.6 Sound insulation	20,101
3.8.6.1 Application	
3.8.6.2 Sound insulation requirements	
3.8.6.3 General installation requirements for walls	
3.8.6.4 Soil and waste pipes	
3.9 Safe movement and access	
3.9.1 Stair construction	21,021
3.9.1 Definitions	
3.9.1.1 Application	
3.9.1.2 General requirements	
3.9.1.3 Stair construction	
3.9.1.4 Riser and going dimensions	
3.9.1.5 Thresholds	
3.9.2 Balustrades	21,201
3.9.2.1 Application	
3.9.2.2 When balustrades or other barriers are required	
3.9.2.3 Balustrade or other barrier construction	
	Continued.

	Page
Continued	
3.9.3 Swimming pool access	21,401
3.9.3.0 Acceptable construction manual	
3.9.3.1 Application	
3.9.3.2 Safety fencing location and construction	
3.10 Additional construction requirements	
3.10.1 High wind areas	23,021
3.10.1.0 Acceptable construction manuals	
3.10.2 Earthquake areas	23,201
3.10.2 Definitions	
3.10.2.0 Acceptable construction manuals	
3.10.2.1 Application	
3.10.2.2 Construction requirements	
3.10.2.3 Construction for areas with an acceleration coefficient of 0.12 or more but less than 0.15	
3.10.2.4 Construction for areas with an acceleration coefficient of 0.15 or more	
3.11 Structural design manuals	
3.11 Acceptable construction manuals	25,021
3.11.1 Application	
3.11.2 Acceptable structural design manuals	
3.11.3 Loading requirements	
3.11.4 Structural design manuals	
APPENDIX A - State and Territory Additions	50,001
INDEX • ABBREVIATIONS AND SYMBOLS	55,001
HISTORY OF AMENDMENTS	57,001
FILING RECORD	

HOW TO USE

GENERAL INFORMATION

The Building Code of Australia (BCA) is in two loose-leaf volumes. It is written and maintained by the Australian Building Codes Board (see “Introduction”).

PAGE NUMBERS

You may notice gaps in the page numbering sequence. These are necessary in a loose-leaf publication so that new material can be easily inserted. Where such a gap occurs, there is a reference to what the next page number will be, for example:

[Next page is 3,601]

CLAUSE NUMBERS

Within each Section, there are a number of Parts and clauses.

The number of the relevant clause (or specification) appears at the bottom of each page.

INDEX

There is a separate Index marked “Index • Abbreviations and Symbols”. It covers the deemed-to-satisfy provisions in the Code. References in the Index are to clauses or specifications.

ABBREVIATIONS AND SYMBOLS

Abbreviations and symbols used in the BCA are conveniently located in the “Index • Abbreviations and Symbols”.

HISTORY OF AMENDMENTS

See under “History of Amendments” for an ongoing record of all amendments to the BCA. This section sets out when the BCA and the amendments are adopted by the Commonwealth and each of the States and Territories. It also sets out a brief summary of the purpose of each amendment to the BCA.

LOOSE-LEAF AMENDMENTS

A loose-leaf amendment contains pages that need to be filed (as a result of amendments to the BCA) into the volume. Each loose-leaf amendment is accompanied by a Filing Record sheet which tells you which pages to remove from the volume and which new ones to insert.

AMENDMENT NUMBER AND DATE OF ADOPTION

Each odd-numbered page of a loose-leaf amendment includes an amendment number located at the top left corner. For example:

Amdt No. 1

This amendment number indicates that the page was inserted by Amendment No 1.

The amendment number, its date of adoption and a summary of changes are provided with each loose-leaf amendment. It is important to check the date of adoption as it may not be the same for all States and Territories (see “History of Amendments”).

Amendments to clauses of the BCA are indicated on the relevant pages.

INTRODUCTION

THE BUILDING CODE OF AUSTRALIA

The Building Code of Australia (BCA) is produced and maintained by the Australian Building Codes Board (ABCB) on behalf of the Commonwealth Government and each State and Territory Government.

The BCA is a uniform set of technical provisions for the design and construction of buildings and other structures throughout Australia. It allows for variations in climate and geological or geographic conditions.

THE AUSTRALIAN BUILDING CODES BOARD

The ABCB is established by agreement between the Commonwealth Government and each State and Territory Government. It is a co-operative arrangement between the signatories, Local Government and the building industry.

It is responsible to the Planning, Housing and Local Government Ministerial Council, and has a mission to achieve nationally consistent performance-based building regulatory systems that are efficient, cost effective and meet community and industry needs.

The Board comprises-

- (a) the principal officer of each State and Territory administration responsible for building regulatory matters; and
- (b) a representative of the Commonwealth; and
- (c) a representative of the Australian Local Government Association (ALGA); and
- (d) industry representatives.

The Building Codes Committee (BCC) is the peak technical advisory body to the ABCB, with responsibility for technical matters associated with the BCA.

The BCC comprises-

- (a) the Executive Director of the ABCB; and
- (b) one nominee each of the Commonwealth, State, Territory and ALGA members of the ABCB; and
- (c) industry members appointed by the ABCB.

THE BCA - CONTENT

GOALS

The goals of the BCA are to enable the achievement and maintenance of acceptable standards of structural sufficiency, safety (including safety from fire), health and amenity for the benefit of the community now and in the future.

These goals are applied so that the BCA extends no further than is necessary in the public interest, is cost effective, easily understood, and is not needlessly onerous in its application.

1996 EDITION

The 1996 edition of the BCA is published in two volumes:

Volume One	pertains primarily to Class 2 to 9 buildings
Volume Two	pertains primarily to Class 1 and 10 buildings (houses, sheds, carports, etc)

Both volumes are drafted in a performance format to provide greater flexibility for the use of new and innovative building products, systems and designs.

A user may choose to comply with the *Deemed-to-Satisfy Provisions* (described as acceptable construction practice in the *Housing Provisions*) or may use an *Alternative Solution* that satisfies the *Performance Requirements*.

The *Deemed-to-Satisfy Provisions* in this edition generally are the same as those contained in the 1990 edition of the BCA for Class 1 and 10 buildings, as amended and includes other changes resulting from the ongoing technical improvement program.

Note: Class 1 buildings are typically single dwelling houses (not located one above the other); Class 10 buildings include carports, sheds, fences, swimming pools, etc, which may be associated with Class 1 buildings as well as Class 2-9 buildings (see Part 1.3 for further information).

STATE AND TERRITORY VARIATIONS AND ADDITIONS

Each State's and Territory's legislation adopts the BCA subject to the variation or deletion of some of its provisions, or the addition of extra provisions. In the *Housing Provisions*, these are divided into two types:

- (a) A variation to the *Housing Provisions* - these are identified following the Clause that is being varied.
- (b) Additional requirements - these are contained in Appendix A (see the tab marked "State and Territory Additions").

SCOPE OF THE HOUSING PROVISIONS

Users of the *Housing Provisions* need to be aware that the acceptable construction practices contained in this document do not cover all types of Class 1 and 10

buildings. The limitations of the acceptable construction practices are discussed in the introduction to Section 3.

DEFINITIONS

Words with special meanings are printed in italics and are defined in 1.1.1 or, if they are specific to a Part, at the start of that Part in Section 3. Defined terms which appear in figures and diagrams may not be in italics.

LEGISLATIVE ARRANGEMENTS

GENERAL

The BCA is given legal effect by building regulatory legislation in each State and Territory. This legislation consists of an Act of Parliament and subordinate legislation which empowers the regulation of certain aspects of buildings and structures, and contains the administrative provisions necessary to give effect to the legislation.

Any provision of the BCA may be overridden by, or subject to, State or Territory legislation. The BCA must therefore be read in conjunction with that legislation. Any queries on such matters should be referred to the State or Territory authority responsible for building regulatory matters.

BCA ADOPTION

The adoption of the 1996 edition of the BCA is addressed in Part 1.0 of the *Housing Provisions*.

DOCUMENTATION OF DECISIONS

Decisions made under the BCA should be fully documented and copies of all relevant documentation should be retained.

Examples of the kind of documentation which should be prepared and retained include:

- (a) Details of the *Building Solution* including all relevant plans and other supporting documentation.
- (b) In cases where an *Alternative Solution* has been proposed—
 - (i) details of the relevant *Performance Requirements*; and
 - (ii) the *Assessment Method* or methods used to establish compliance with the relevant *Performance Requirements*; and
 - (iii) details of any *Expert Judgement* relied upon including the extent to which the judgement was relied upon and the qualifications and experience of the expert; and

- (iv) details of any tests or calculations used to determine compliance with the relevant *Performance Requirements*; and
- (v) details of any Standards or other information which were relied upon.

STRUCTURE

The BCA has been structured as set out in 1.0.3 and shown in Figure 1.0.3. It is the ABCB's intent that the *Objectives* and *Functional Statements* be used as an aid to the interpretation of the BCA and not for determining compliance with the BCA.

FURTHER DEVELOPMENT

Regular amendments are planned to the BCA to improve clarity of provisions, upgrade referenced documents and to reflect the results of research and improved technology.

The ABCB's intention is that the performance provisions of the BCA will be progressively developed. Later stages will therefore include reviewed *Objectives*, *Functional Statements* and *Performance Requirements*.

COMMENTS

Comments in writing on any matter concerning the text, presentation or further development of the BCA are invited from building and other authorities, industry organisations, professional operatives and the public generally. These comments should be addressed to:

Executive Director
Australian Building Codes Board
GPO Box 9839
CANBERRA ACT 2601

SECTION **1**

Amdt 3

GENERAL REQUIREMENTS

- 1.0 Application
- 1.1 Interpretation
- 1.2 Acceptance of Design and Construction
- 1.3 Classification
- 1.4 Standards adopted by reference

SECTION 1 CONTENTS

		Page
1.0	Application	2,015
1.0.1	Adoption	
1.0.2	BCA Volumes	
1.0.3	BCA Structure	
1.0.4	Compliance with the BCA	
1.0.5	Meeting the Performance Requirements	
1.0.6	Objectives and Functional Statements	
1.0.7	Deemed to Satisfy Provisions	
1.0.8	Alternative Solutions	
1.0.9	Assessment Methods	
1.1	Interpretation	2,021
1.1.1	Definitions	
1.1.2	Adoption of referenced documents	
1.1.3	Context of reference	
1.1.4	Differences between referenced documents and the Housing Provisions	
1.1.5	Application of the Housing Provisions to a particular State or Territory	
1.1.6	Language	
1.1.7	Interpretation of diagrams	
1.1.8	Explanatory information	
1.2	Acceptance of design and construction	2,201
1.2.1	Suitability of materials	
1.2.2	Evidence of suitability	
1.2.3	Fire resistance of building elements	
1.2.4	Early fire hazard indices	
1.3	Classification of buildings	2,401
1.3.1	Principles of classification	
1.3.2	Classification	
1.3.3	Multiple Classifications	
1.4	Standards adopted by reference	2,601
1.4.1	Schedule of reference documents	

PART 1.0 APPLICATION

1.0.1 Adoption

1.0.1
Amdt No.2

The dates of adoption of the 1996 edition of the Building Code of Australia (Volume Two) and its amendments are shown in the “History of Amendments” division at the end of this Volume.

1.0.2 BCA Volumes

- (a) This is Volume Two of the Building Code of Australia 1996 (hereafter described as the *Housing Provisions*) which contains the requirements for-
 - (i) Class 1 and 10 buildings (other than access requirements for people with disabilities in Class 10 buildings); and
 - (ii) certain Class 10 structures.
- (b) Volume One contains the requirements for-
 - (i) all Class 2 to 9 buildings; and
 - (ii) access requirements for people with disabilities in Class 10 buildings (Part D3); and
 - (iii) certain Class 10 structures.

1.0.3 BCA Structure

The structure of the BCA comprises the following as shown in Figure 1.0.3:

- (a) The *Objectives*.
- (b) The *Functional Statements*.
- (c) The *Performance Requirements* with which all *Building Solutions* must comply.
- (d) The *Building Solutions*.

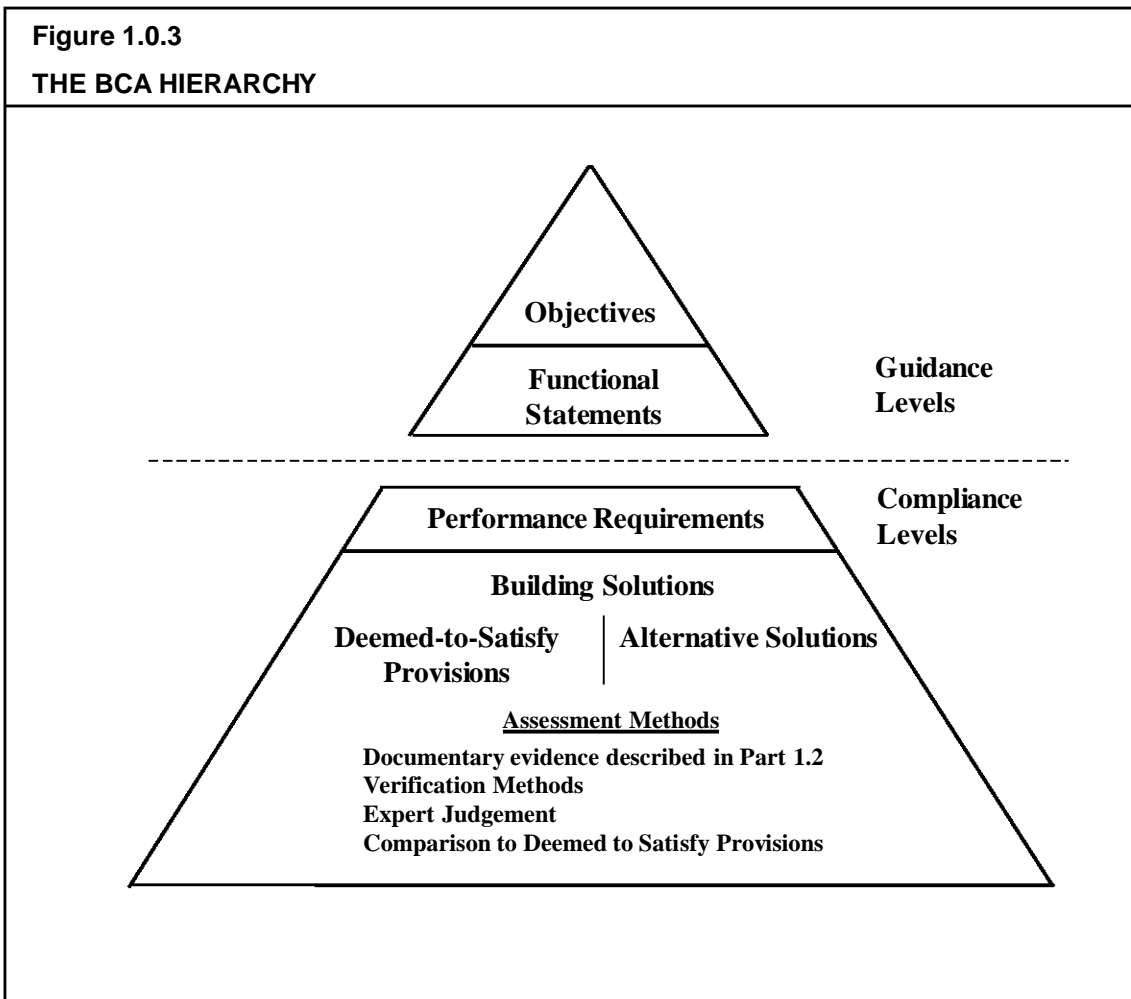

1.0.4 Compliance with the BCA

A *Building Solution* will comply with the BCA if it satisfies the *Performance Requirements*.

1.0.5 Meeting the Performance Requirements

Compliance with the *Performance Requirements* can only be achieved by—

- (a) complying with the *Deemed-to-Satisfy Provisions*; or
- (b) formulating an *Alternative Solution* which—
 - (i) complies with the *Performance Requirements*; or
 - (ii) is shown to be at least *equivalent* to the *Deemed-to-Satisfy Provisions*;
or
- (c) a combination of (a) and (b).

1.0.6 Objectives and Functional Statements

The *Objectives and Functional Statements* may be used as an aid to interpretation.

1.0.7 Deemed-to-Satisfy Provisions

A *Building Solution* which complies with the *Deemed-to-Satisfy Provisions* is deemed to comply with the *Performance Requirements*.

1.0.8 Alternative Solutions

- (a) An *Alternative Solution* must be assessed according to one or more of the *Assessment Methods*.
- (b) An *Alternative Solution* will only comply with the BCA if the *Assessment Methods* used to determine compliance with the *Performance Requirements* have been satisfied.

1.0.9 Assessment Methods

The following *Assessment Methods*, or any combination of them, can be used to determine that a *Building Solution* complies with the *Performance Requirements*:

- (a) Evidence to support that the use of a material, form of construction or design meets a *Performance Requirement* or a *Deemed-to-Satisfy Provision* as described in 1.2.2.
- (b) *Verification Methods* such as—
 - (i) the *Verification Methods* in the BCA; or
 - (ii) such other *Verification Methods* as the *appropriate authority* accepts for determining compliance with the *Performance Requirements*.
- (c) Comparison with the *Deemed-to-Satisfy Provisions*.
- (d) *Expert Judgement*.

PART 1.1 INTERPRETATION

1.1.1 Definitions

1.1.1.1 In the *Housing Provisions*, definitions are contained as follows:

- (a) In 1.1.1 for definitions that apply to all of the *Housing Provisions*.
- (b) In each Part (as applicable) for definitions that apply to that Part only.

1.1.1.2 In the *Housing Provisions*, unless the contrary appears:

Alpine area means land-

- (a) likely to be subject to significant snowfalls; and
- (b) in New South Wales, ACT or Victoria more than 1200 m above the Australian Height Datum; and
- (c) in Tasmania more than 900 m above the Australian Height Datum.

Explanatory Information:

See Part 3.7.5 for map of *alpine areas*.

Alteration, in relation to a building, includes an addition or extension to a building.

Alternative Solution means a *Building Solution* which complies with the *Performance Requirements* other than by reason of complying with the *Deemed-to-Satisfy Provisions*.

Appropriate authority means the relevant authority as determined by the building regulatory legislation in each State and Territory.

Assessment Method means a method used for determining or establishing that a *Building Solution* complies with the *Performance Requirements*.

Automatic, applied to a fire door, smoke door, solid core door, fire shutter, fire window, smoke-and-heat vent, sprinkler system, alarm system or the like, means designed to operate when activated by a heat, smoke or fire sensing device.

Average recurrence interval applied to rainfall, means the average or expected interval between events of a given rainfall intensity being exceeded.

Building Solution means a solution which complies with the *Performance Requirements* and is-

- (a) an *Alternative Solution*; or
- (b) a solution which complies with the *Deemed-to-Satisfy Provisions*; or
- (c) a combination of (a) and (b).

Certificate of Accreditation means a certificate issued by ABCB or a State or Territory accreditation authority stating that the properties and performance of a building material or method of construction or design fulfil specific requirements of the *Housing Provisions*.

Certificate of Conformity means a certificate issued by ABCB stating that the properties and performance of a building material or method of construction or design fulfil specific requirements of the *Housing Provisions*.

Combustible-

- (a) applied to a material - means *combustible* under AS 1530.1; or
- (b) applied to construction or part of a building - means constructed wholly or in part of *combustible* materials.

Common wall means a wall that is common to adjoining buildings other than Class 1 buildings.

Deemed-to-Satisfy Provisions means provisions contained in Section 3 which are deemed to comply with the *Performance Requirements*.

Designated bushfire prone area means land which has been declared by appropriate legislation to be likely to be subject to bushfires.

Design wind speed means the design gust wind speed for the area where the building is located, calculated in accordance with AS 1170.2 or AS 4055 (see Table 1.1.1 for *Housing Provisions design wind speed* descriptions and equivalent values).

Table 1.1.1				
DESIGN WIND SPEED - EQUIVALENT VALUES				
Note:				
1. Wind classification map identifying cyclonic areas (as per AS 4055) is contained in Part 3.10.1.				
2. Information on wind speeds for particular areas may be available from the <i>appropriate authority</i> .				
3. = <i>design wind speed</i> areas covered by Part 3.10.1, High wind areas.				
Housing Provisions description	EQUIVALENT VALUES			
	Wind Class - AS 4055			Design gust wind speed (m/sec) - AS 1170.2
	km/h	For non-cyclonic regions A and B	For cyclonic regions C and D	Permissible stress method only
W28	101	N1	-	28
W33	119	N2	-	33
W41	148	N3	C1	41
W50	180	N4	C2	50
W60	216	N5	C3	60
W70	252	N6	C4	70

Equivalent means equivalent to the level of health, safety and amenity provided by the *Deemed-to-Satisfy Provisions*.

Expert Judgement means the judgement of an expert who has the qualifications and experience to determine whether a *Building Solution* complies with the *Performance Requirements*.

External wall means an outer wall of a building which is not a *separating wall*.

Fire-resistance level (FRL) means the grading periods in minutes determined in accordance with Specification A2.3 of BCA Volume One, for-

- (a) *structural adequacy*; and
- (b) *integrity*; and
- (c) *insulation*,

and expressed in that order.

A dash means there is no requirement for that criterion. For example, 90/-/- means there is no FRL for integrity and insulation.

Fire-resisting, applied to a *structural member* or other part of a building, means having the FRL *required* for that *structural member* or other part.

Flammability Index means the index number determined under AS 1530.2.

Floor area means, in relation to a room, the area of the room measured within the finished surfaces of the walls, and includes the area occupied by any cupboard or other built-in furniture, fixture or fitting (see Figure 1.1.1).

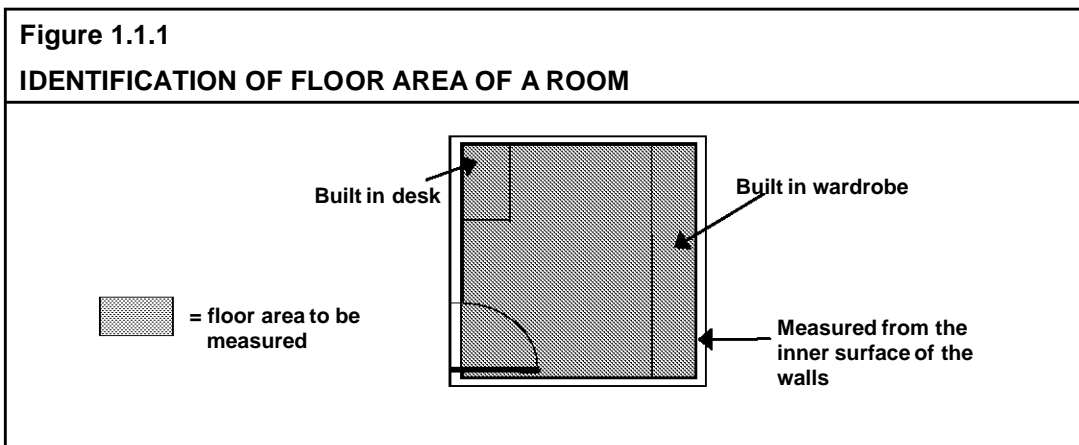

Foundation means the ground which supports the building (see Figure 1.1.2).

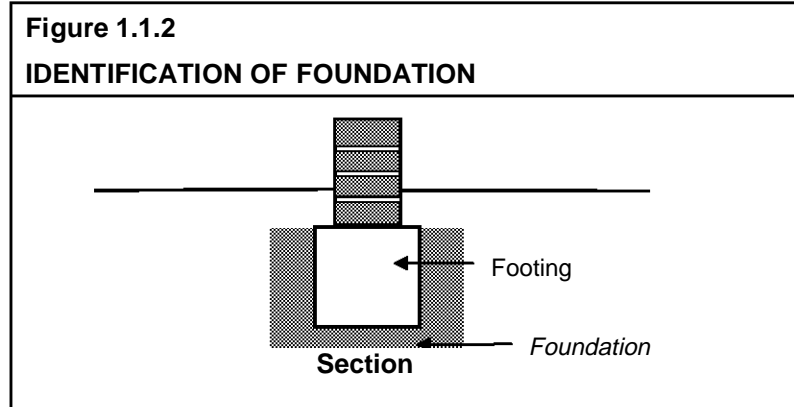

Functional Statement means a statement which describes how buildings and building elements achieve the *Objectives*.

Habitable room means a room used for normal domestic activities, and-

- (a) includes a bedroom, living room, lounge room, music room, television room, kitchen, dining room, sewing room, study, playroom, family room and sunroom; but
- (b) excludes a bathroom, laundry, water closet, pantry, walk-in wardrobe, corridor, hallway, lobby, photographic darkroom, clothes-drying room, and other spaces of a specialised nature occupied neither frequently nor for extended periods.

High wind area means a region that is subject to *design wind speeds* more than W41 (see Table 1.1.1).

Housing Provisions means the requirements for Class 1 and 10 buildings contained in Volume Two of the Building Code of Australia 1996 as published by the Australian Building Codes Board.

Illuminance means the luminous flux falling onto a unit area of surface.

Insulation, in relation to an FRL, means the ability to maintain a temperature on the surface not exposed to the furnace below the limits specified in AS 1530.4.

Integrity, in relation to an FRL, means the ability to resist the passage of flames and hot gases specified in AS 1530.4.

Internal wall excludes a *separating wall*, *common wall* or party wall.

Lightweight construction means construction which incorporates or comprises-

- (a) sheet or board material, plaster, render, sprayed application, or other material similarly susceptible to damage by impact, pressure or abrasion; or
- (b) concrete and concrete products containing pumice, perlite, vermiculite, or other soft material similarly susceptible to damage by impact, pressure or abrasion; or
- (c) masonry having a thickness less than 70 mm.

Loadbearing means intended to resist vertical forces additional to those due to its own weight.

Non-combustible-

- (a) applied to a material - means not deemed *combustible* under AS 1530.1 - Combustibility Tests for Materials; and
- (b) applied to construction or part of a building - means constructed wholly of materials that are not deemed *combustible*.

Objective means a statement contained in the BCA which is considered to reflect community expectations.

Other property means all or any of the following-

- (a) any building, whether or not on the same or an adjoining allotment; and
- (b) any adjoining allotment; and
- (c) a road.

Outdoor air means air outside the building.

Outfall means that part of the disposal system receiving *surface water* from the drainage system and may include a natural water course, kerb and channel, or soakage system.

Performance Requirement means a requirement which states the level of performance which a *Building Solution* must meet.

Private garage means-

- (a) any garage associated with a Class 1 building; or
- (b) any separate single storey garage associated with another building where such garage is capable of accommodating not more than 3 vehicles.

Professional engineer means a person who is-

- (a) if legislation is applicable - a registered *professional engineer* in the relevant discipline who has appropriate experience and competence in the relevant field; or
- (b) if legislation is not applicable-

- (i) a Corporate Member of the Institution of Engineers, Australia; or
- (ii) eligible to become a Corporate Member of the Institution of Engineers, Australia, and has appropriate experience and competence in the relevant field.

Registered Testing Authority means-

- (a) the National Building Technology Centre (NBTC); or
- (b) the CSIRO Division of Building, Construction and Engineering (CSIRO-DBC&E); or
- (c) an authority registered by the National Association of Testing Authorities (NATA) to test in the relevant field; or
- (d) an organisation outside Australia recognised by NATA through a mutual recognition agreement.

Required means required to satisfy a *Performance Requirement* or a *Deemed-to-Satisfy Provision* of the *Housing Provisions* as appropriate.

Sanitary compartment means a room or space containing a toilet fixture, closet pan, soil pan, chemical toilet, or the like.

Sarking-type material means a material such as a reflective foil or other flexible membrane of a type normally used for a purpose such as waterproofing, vapour proofing or thermal reflectance.

Self-closing, applied to a door or *window* means equipped with a device which returns the door or *window* to the fully closed and latched position immediately after each manual opening.

Separating wall means a wall that is common to adjoining Class 1 buildings (see Figure 1.1.3).

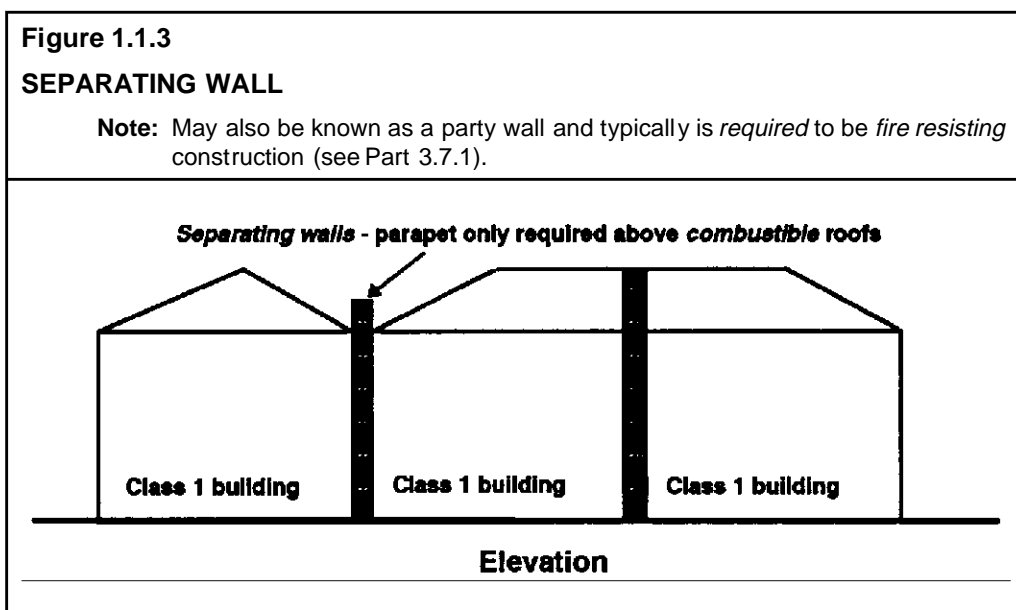

Amdt 3

- Site** means the part of the allotment of land on which a building stands or is to be erected.
- Sitework** means work on or around a *site*, including earthworks, preparatory to or associated with the construction, *alteration*, demolition or removal of a building.
- Smoke-Developed Index** means the index number for smoke developed under AS 1530 .3
- Spread-of-Flame Index** means the index number for spread of flame under AS 1530.3
- Standard Fire Test** means the Fire-resistance Test of Elements of Building Construction as described in AS 1530.4.
- Structural adequacy**, in relation to an FRL means the ability to maintain stability and adequate *loadbearing* capacity under AS 1530.4.
- Structural member** means a component or part of an assembly which provides vertical or lateral support to a building or structure.
- Surface water** means all naturally occurring water, other than sub-surface water, which results from rainfall on or around the *site* or water flowing onto the *site*, including that flowing from a drain, stream, river, lake or sea.
- Swimming pool** means any excavation or structure containing water and used principally for swimming, wading, paddling, or the like, including a bathing or wading pool, or spa.
- Verification Method** means a test, inspection, calculation or other method that determines whether a *Building Solution* complies with the relevant *Performance Requirements*.
- Window** includes a roof light, glass panel, glass block or brick, glass louvre, glazed sash, glazed door, or other device which transmits natural light directly from outside a building to the room concerned when in the closed position.

1.1.2 Adoption of referenced documents

Where a *Deemed-to-Satisfy Provision* adopts a Standard, rule, specification or provision included in any document issued by Standards Australia or other body, that adoption does not include a provision-

- (a) specifying or defining the respective rights, responsibilities or obligations as between themselves of any manufacturer, supplier or purchaser; or
- (b) specifying the responsibilities of any trades person or other building operative, architect, engineer, authority, or other person or body; or
- (c) requiring the submission for approval of any material, building component, form or method of construction, to any person, authority or body other than a person or body empowered under State or Territory legislation to give that approval; or
- (d) specifying that a material, building component, form or method of construction must be submitted to Standards Australia or a committee of Standards Australia for expression of opinion; or
- (e) permitting a departure from the code, rule, specification or provision at the sole discretion of the manufacturer or purchaser, or by arrangement or agreement between the manufacturer and purchaser.

1.1.3 Context of reference

A reference in a *Deemed-to-Satisfy Provision* to a document under 1.1.2 refers to the edition or issue, together with any amendment, listed in Part 1.4 and only so much as is relevant in the context in which the document is quoted.

1.1.4 Differences between referenced documents and the Housing Provisions

The *Housing Provisions* overrule in any difference arising between it and any Standard, rule, specification or provision in a document listed in Part 1.4.

1.1.5 Application of the Housing Provisions to a particular State or Territory

For application within a particular State or Territory, the *Housing Provisions* comprise-

- (a) Sections 1 to 3 (inclusive); and
- (b) the variations and deletions applicable to that State or Territory specified in Sections 1 to 3 inclusive; and
- (c) the additions to Sections 1 to 3 inclusive applicable to that State or Territory specified in the relevant Appendix.

1.1.6 Language

A reference to a building in the *Housing Provisions* is a reference to an entire building or part of a building, as the case requires.

1.1.7 Interpretation of diagrams

Diagrams in the *Housing Provisions* are used to describe specific issues referenced in the associated text. They are not to be construed as containing all design information that is *required* for that particular building element or situation.

Explanatory Information:

Diagrams are used to explain the requirements of a particular clause. To ensure the context of the requirement is clearly understood, adjacent construction elements of the building that would normally be required in that particular situation are not always shown.

ie. Diagrams to show the installation of damp proof courses will only depict the damp proof course and associated masonry. It will not necessarily show non-related items such as wall ties, adjacent timber flooring, reinforcing for any footing etc.

Accordingly, aspects of a diagram that are not shown should not be interpreted as meaning these construction details are not *required*.

1.1.8 Explanatory information

These elements of the *Housing Provisions* are non-mandatory. They are used to provide additional guidance on the application of the particular Parts and clauses and do not need to be followed to meet the requirements of the *Housing Provisions*.

PART 1.2 ACCEPTANCE OF DESIGN AND CONSTRUCTION

1.2.1 Suitability of materials

Every part of a building must be constructed in an appropriate manner to achieve the requirements of the *Housing Provisions*, using materials that are fit for the purpose for which they are intended.

1.2.2 Evidence of suitability

- (a) Subject to 1.2.3 and 1.2.4, evidence to support that the use of a material, form of construction or design meets a *Performance Requirement* or a *Deemed-to-Satisfy Provision* may be in the form of one or a combination of the following:
- (i) A report issued by a *Registered Testing Authority*, showing that the material or form of construction has been submitted to the tests listed in the report, and setting out the results of those tests and any other relevant information that demonstrates its suitability for use in the building.
 - (ii) A current *Certificate of Conformity* issued by the ABCB or a current *Certificate of Accreditation*.
 - (iii) A certificate from a *professional engineer* or other appropriately qualified person which-
 - (A) certifies that a material, design or form of construction complies with the requirements of the *Housing Provisions*; and
 - (B) sets out the basis on which it is given and the extent to which relevant specifications, rules, codes of practice or other publications have been relied upon.
 - (iv) A current certificate issued by a product certification body that has been accredited by the Joint Accreditation Scheme of Australia and New Zealand (JAS-ANZ).
 - (v) A current SSL Product Listing Data Sheet and listing in the latest issue of the Scientific Services Laboratory Register of Accredited Products - Fire Protection Equipment.
 - (vi) Any other form of documentary evidence that correctly describes the properties and performance of the material or form of construction and adequately demonstrates its suitability for use in the building.
- (b) Any copy of documentary evidence submitted, must be a complete copy of the original report or document.

1.2.3 Fire resistance of building elements

Where a *Deemed-to-Satisfy Provision* requires a building element to have an FRL, it must comply with the acceptable construction method or be determined in accordance with Specification A2.3 of BCA Volume One.

1.2.4 Early Fire Hazard Indices

Where a *Deemed-to-Satisfy Provision* requires a building component or assembly to have an Early Fire Hazard Index, it must be determined in accordance with Specification A2.4 of BCA Volume One.

Explanatory information:

The provisions of Part 1.2 list acceptable methods to enable verification and acceptance of both the performance (listed in Section 2) and deemed-to-satisfy options (listed in Section 3) of the *Housing Provisions*.

PART 1.3 CLASSIFICATION

1.3.1 Principles of classification

The classification of a building or part of a building is determined by the purpose for which it is designed, constructed or adapted to be used.

Explanatory Information:

1. Class 1 and 10 buildings are classified in accordance with this Part; and
2. Class 2 to 9 buildings are classified in accordance with Section A of BCA, Volume One.

1.3.2 Classification

Class 1 and 10 buildings are classified as follows:

Class 1 - one or more buildings, which in association constitute-

- (a) **Class 1a** - a single dwelling being-
 - (i) a detached house; or
 - (ii) one or more attached dwellings, each being a building, separated by a *fire-resisting* wall, including a row house, terrace house, town house or villa unit; or
- (b) **Class 1b** - a boarding house, guest house, hostel or the like with a total floor area not exceeding 300 m² and in which not more than 12 persons would ordinarily be resident;

which is not located above or below another dwelling or another Class of building other than a *private garage* (see Figures 1.3.1, 1.3.2 and 1.3.3).

Class 10 - a non-habitable building or structure being -

- (a) **Class 10a** - a non-habitable building being a *private garage*, carport, shed, or the like; or
- (b) **Class 10b** - a structure being a fence, mast, antenna, retaining or free-standing wall, *swimming pool*, or the like.

(see Figure 1.3.3).

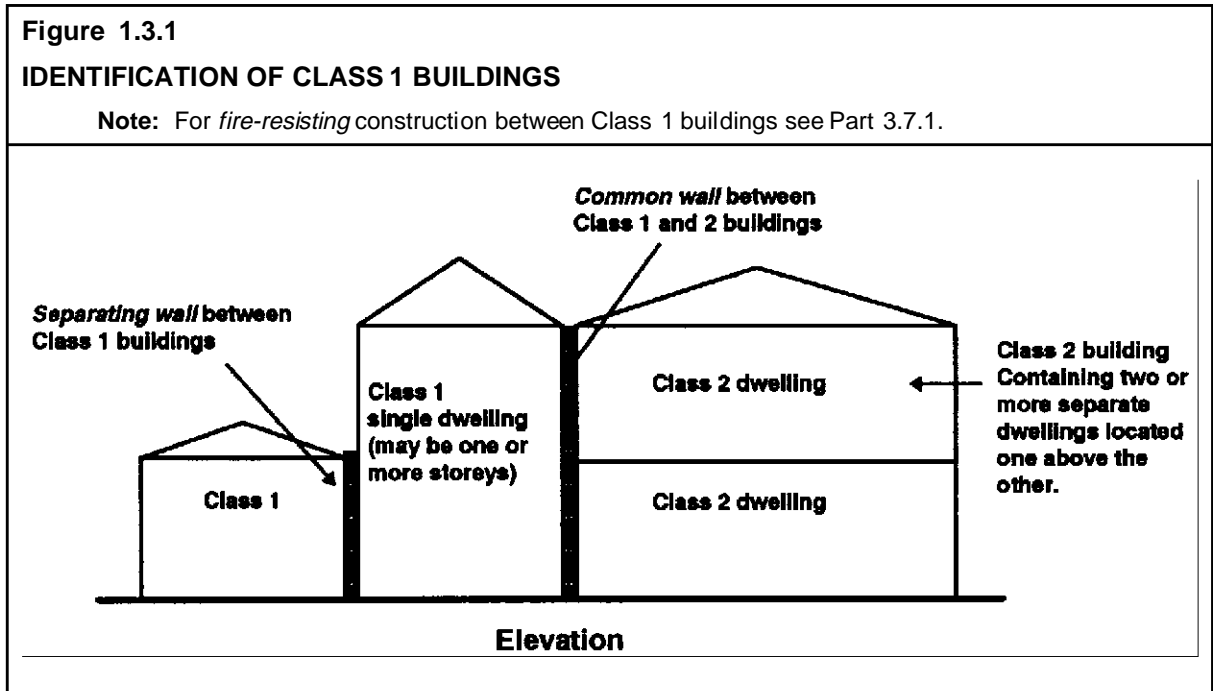

Amdt 3

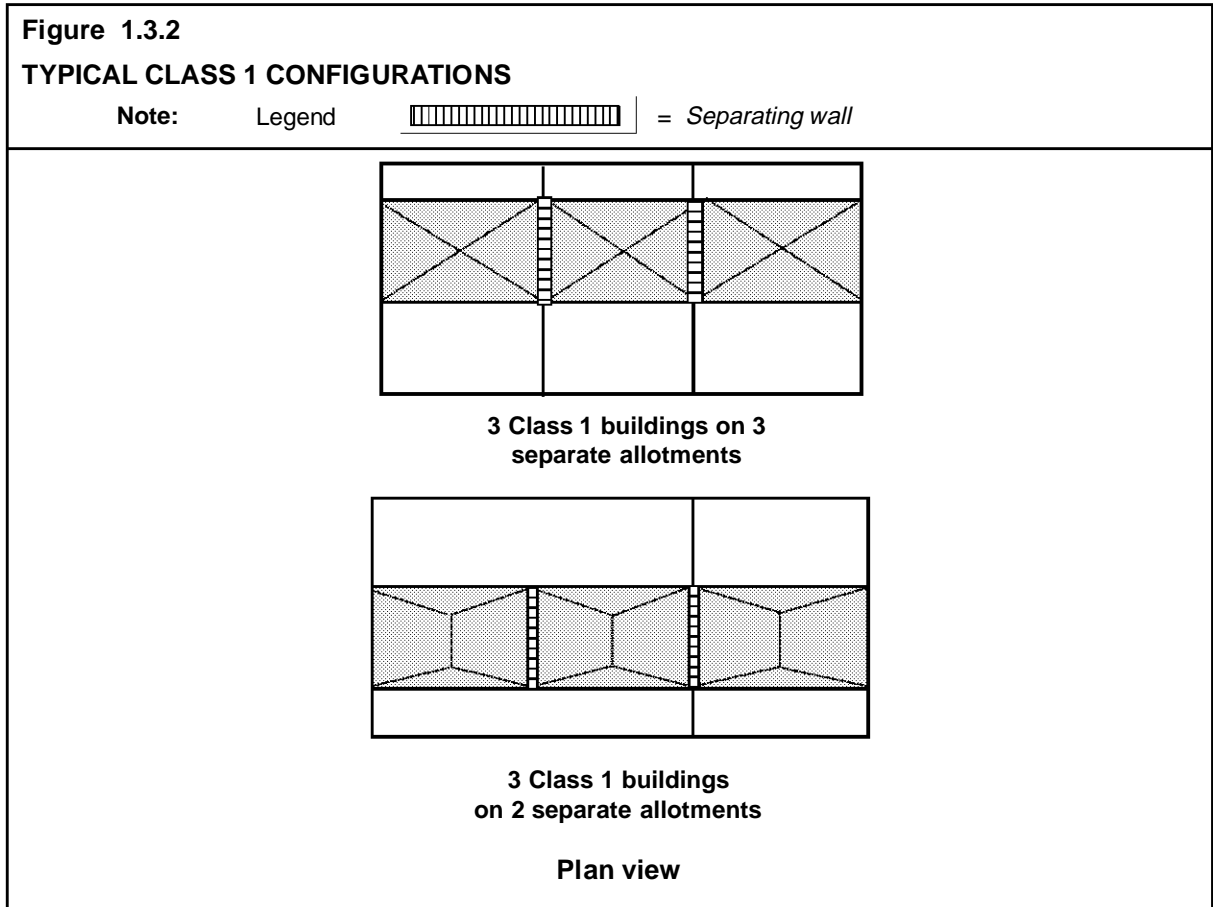

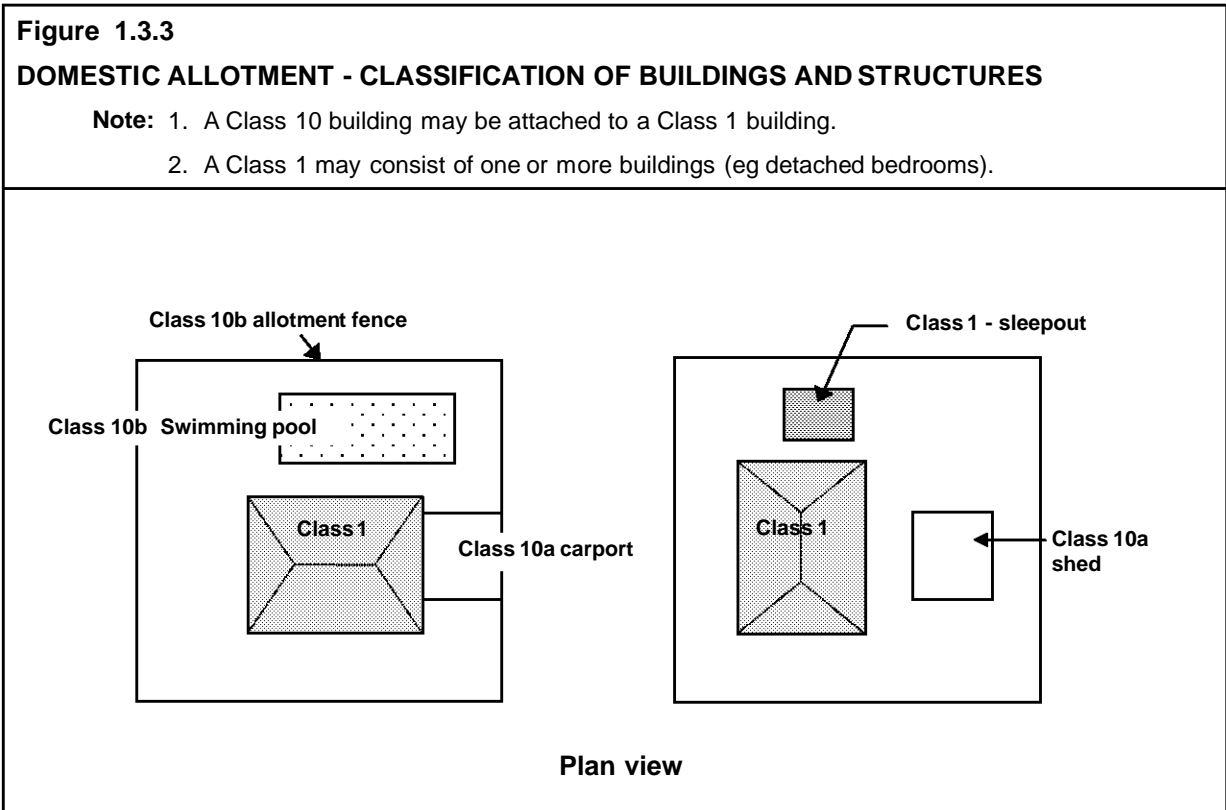

Amdt 3

1.3.3 Multiple classifications

Each part of a building must be classified separately, and-

- (a) Classes 1a, 1b, 10a and 10b are separate classifications; and
- (b) a reference to -
 - (i) Class 1 - is to Class 1a and 1b; and
 - (ii) Class 10 - is to Class 10a and 10b; and
- (c) where parts have different purposes - if not more than 10% of the *floor area* of a Class 1 building is used for a purpose which is a different classification, the classification of Class 1 may apply to the whole building.

1.3.3(c)
Amdt No. 2

PART 1.4 STANDARDS ADOPTED BY REFERENCE

1.4.1 Schedule of referenced documents

The Standards and other documents listed in Table 1.4.1 are referred to in the *Housing Provisions*.

Table 1.4.1: SCHEDULE OF REFERENCED DOCUMENTS		
No.	Date	Title
AS 1170		Minimum design loads on structures (SAA Loading Code)
Part 1	1989	Dead and live loads and load combinations Amdt 1, Jan 1993
Part 2	1989	Wind loads Amdt 1, Jan. 1991 Amdt 2, Jan 1993 Amdt 3, Dec 1993
Part 3	1990	Snow loads
Part 4	1993	Earthquake loads Amdt 1, Oct 1994
AS/NZS 1200	1994	Pressure equipment
AS 1250	1981	The use of steel in structures (SAA Steel Structures Code) Amdt 2, Oct. 1984
AS 1273	1991	Unplasticized PVC (UPVC) downpipe and fittings for rainwater
AS 1276	1979	Methods for determination of Sound Transmission Class and Noise Isolation Class of building partitions
AS 1288	1994	Glass in buildings - Selection and Installation Amdt 1, Sept. 1997
AS 1289	1984	Methods of testing soils for engineering purposes
Method 6.3.3	1997	Determination of the penetration resistance of a soil - Perth sand penetrometer test
AS 1397	1993	Steel sheet and strip – Hot-dipped zinc-coated or aluminium/zinc coated
AS 1526	1974	One-part polysulphide based sealing compounds for the building industry
AS 1527	1974	Two-part polysulphide based sealing compounds for the building industry

AS 1288
Amdt No. 3

AS 1289
Amdt No. 2

AS 1397
Amdt No. 3

Amdt 3

Table 1.4.1: SCHEDULE OF REFERENCED DOCUMENTS (Continued)		
No.	Date	Title
AS 1530		Methods for fire tests on building materials components and structures
Part 1	1994	Combustibility test for materials
Part 2	1993	Test for flammability of materials Amdt 1, July 1993
Part 3	1989	Simultaneous determination of ignitability, flame propagation, heat release and smoke release Amdt 1, April 1992
Part 4	1990	Fire-resistance tests on elements of building construction [Note: Subject to the note to AS 4072.1, reports relating to tests carried out under earlier editions of AS 1530 Parts 1 to 4 remain valid. Reports relating to tests carried out after the date of an amendment to a Standard must relate to the amended Standard]
AS 1562		Design and installation of sheet roof and wall cladding
Part 1	1992	Metal Amdt 1, July 1993 Amdt 2, Sept 1995
Part 3	1996	Plastics
AS 1639	1990	The design and installation of corrugated fibre-reinforced cement roofing and wall cladding Amdt 1, May 1991
AS 1657	1992	Fixed platforms, walkways, stairways and ladders - Design, construction and installation (SAA Code for Fixed Platforms, Walkways, Stairways and Ladders)
AS/NZS 1664		Aluminium structures
Part 1	1997	Limit state design
Part 2	1997	Allowable stress design
AS 1668		The use of mechanical ventilation and air-conditioning in buildings
Part 2	1991	Mechanical ventilation for acceptable indoor-air quality
AS 1680		Interior lighting
Part 1	1990	General principles and recommendations Amdt 1, June 1993
Part 2.0	1990	Recommendations for specific tasks and interiors Amdt 1, Dec 1992
Part 2.1	1993	Circulation space and other general areas
AS 1684	1992	National Timber Framing Code Amdt 1, Sept 1993 Amdt 2, June 1994 Amdt 3, Dec 1995

Amdt 3

AS 1562.3
Amdt No. 3

AS/NZS 1664
Amdt No. 3

Table 1.4.1 continued		
SCHEDULE OF REFERENCED DOCUMENTS (Continued)		
No.	Date	Title
AS 1691	1985	Domestic oil-fired appliances – Installation Amdt 1, Sept. 1985
AS 1720		Timber structures (SAA Timber Structures Code)
Part 1	1997	Design methods
AS/NZS 1859	1997	Reconstituted wood-based panels
Part 1	1997	Particleboard
AS 1860	1998	Installation of particleboard flooring
AS 1926		Swimming pool safety
Part 1	1993	Fencing for swimming pools
Part 2	1995	Location of fencing for private swimming pools
AS 2049	1992	Roof tiles
AS 2050	1995	Installation of roof tiles Amdt 1, Sept 1995
AS 2159	1995	Rules for the design and installation of piles (SAA Piling Code) Amdt 1, April 1996
AS/NZS 2179		Specification for rainwater goods, accessories and fasteners
Part 1	1994	Metal shape or sheet rainwater goods and metal accessories and fasteners
AS 2185	1991	Fibrous plaster products
AS/NZS 2269	1994	Plywood-structural
AS 2327		Composite construction in structural steel and concrete (SAA Composite Construction Code)
Part 1	1996	Simply supported beams
AS 2699	1984	Wall ties for masonry construction Amdt 1, Nov 1984 Amdt 2, Dec 1986
AS 2867	1986	Farm structures - General requirements for structural design
AS 2870		Residential slabs and footings - Construction Amdt 1, Jan 1997
AS/NZS 2904	1995	Damp-proof courses and flashings Amdt 1, March 1998
AS 2908		Cellulose cement products
Part 1	1992	Corrugated sheets Amdt 1, Feb 1994
Part 2	1992	Flat sheets
AS 2918	1990	Domestic solid-fuel burning appliances-Installation

AS 1720
Amdt No. 3

AS 1860
Amdt No. 3

AS 2699
Amdt No. 2

AS/NZS
2904
Amdt No. 3

Amdt 3

Table 1.4.1 continued		
SCHEDULE OF REFERENCED DOCUMENTS (Continued)		
No.	Date	Title
AS/NZS 3500		National plumbing and drainage code
Part 3.2	1998	Storm water drainage – Acceptable solutions
AS 3566	1988	Screws – Self-drilling-for the building and construction industries Amdt 1 July 1990
AS 3600	1994	Concrete structures Amdt 1, Aug 1996
AS 3623	1993	Domestic metal framing
AS 3660		Protection of buildings from subterranean termites
Part 1	1995	New buildings Amdt 1, Dec 1996
AS 3700	1988	Masonry Structures
AS 3740	1994	Waterproofing of wet areas in residential buildings Amdt 1, Sept 1995
AS 3786	1993	Smoke alarms Amdt 1, April 1994 Amdt 2, Dec 1995
AS 3798	1996	Guidelines on earthworks for commercial and residential developments
AS 3958		Ceramic tiles
Part 1	1991	Guide to the installation of ceramic tiles Amdt 1, Jan 1992
AS 3959	1991	Construction of buildings in bushfire prone areas
AS 4055	1992	Wind loads for housing Amdt 1, Dec 1994
AS 4100	1998	Steel Structures
AS/NZS 4200		Pliable building membranes and underlays
Part 1	1994	Materials Amdt 1, Dec 1994
Part 2	1994	Installation requirements
AS/NZS 4256		Plastic roof and wall cladding material
Part 1	1994	General requirements
Part 2	1994	Unplasticized polyvinyl chloride (UPVC) building sheets
Part 3	1994	Glass fibre reinforced polyester (GRP)
Part 5	1996	Polycarbonate

AS/NZS 3500
Amdt No. 3AS 3700
Amdt No. 3AS 3798
Amdt No. 2AS 4100
Amdt No. 3

Amdt 3

Table 1.4.1 continued

SCHEDULE OF REFERENCED DOCUMENTS (Continued)

No.	Date	Title
AS/NZS 4600	1996	Cold-formed steel structures
ASTM D3018-90	1994	Class A asphalt shingles surfaced with mineral granules
CSIRO- DBC&E	1975	Special report-low rise domestic and similar framed structures Part 4- Supplementary domestic buildings for built-up areas sections I to V
CSIRO-NBTC	1987	Bulletin 5- Earth-wall Construction 4th edition
Northern Territory Deemed to comply Standards manual		
SSL		Register of Accredited Products - Fire Protection Equipment
TN 61		Cement and Concrete Association of Australia Articulated walling
Timber framing manual - 1994		Timber Promotion Council - Victoria
Timber framing manual Supplementary tables - 1995		Timber Promotion Council - Victoria
NSW Timber framing manual - 1994		State Forest of NSW
Timber framing manual W33N-W41N - 1994		Timber Research and Development Advisory Council - Queensland
Timber framing manual W41C 1993		Timber Research and Development Advisory Council - Queensland
Timber framing manual W50C 1994		Timber Research and Development Advisory Council - Queensland
Timber framing manual W60C - 1992		Timber Research and Development Advisory Council - Queensland

Deletions
Amdt No. 2

Amdt 3

STATE AND TERRITORY VARIATIONS - SCHEDULE OF REFERENCE DOCUMENTS		
AUSTRALIAN CAPITAL TERRITORY REFERENCED DOCUMENTS		
No.	Date	Title
		Worksafe Australia Asbestos Code of Practice and Guidance Notes, August 1988
SOUTH AUSTRALIAN REFERENCED DOCUMENTS		
South Australian Housing Code 1996		
SA G5.101	1998	South Australian Minister's Specification - Construction of buildings in bushfire prone areas
SA F1.7	1998	South Australian Minister's Specification - Waterproofing of wet areas in buildings
AS 1428	1993	Design for access and mobility Part 1: General requirements for access - buildings.
AS 1926		Swimming pool safety
Part 3	1993	Water recirculation and filtration systems
VICTORIAN REFERENCED DOCUMENTS		
House energy rating		Energy Victoria June 1994
TASMANIAN REFERENCED DOCUMENTS		
AS 1926		Swimming pool safety
Part 3	1993	Water recirculation and filtration systems

Deletion
Amdt No. 3

SA G5.101
Amdt No. 3

SA F1.7
Amdt No. 3

AS 1428.1
Amdt No. 2

AS 1926.3
Amdt No. 2

Deletions
Amdt No. 2

AS 1926.3
Amdt No. 2

Amdt 3

SECTION **2**

Amdt 3

PERFORMANCE PROVISIONS

Objectives

Functional Statements

Performance Requirements

- 2.1 Structure**
- 2.2 Damp and weatherproofing**
- 2.3 Fire safety**
- 2.4 Health and amenity**
- 2.5 Safe movement and access**

SECTION 2 CONTENTS

		Page
2.0	Application	3,021
2.1	Structure	3,031
2.2	Damp and weatherproofing	3,201
P2.2.1	Surface water	
P2.2.2	Weatherproofing	
P2.2.3	Dampness	
P2.2.4	Drainage from swimming pools	
2.3	Fire safety	3,401
P2.3.1	Protection from the spread of fire	
P2.3.2	Fire detection and early warning	
P2.3.3	Heating appliances	
P2.3.4	Bushfire areas	
P2.3.5	Alpine areas	
2.4	Health and amenity	3,601
P2.4.1	Wet areas	
P2.4.2	Room heights	
P2.4.3	Facilities	
P2.4.4	Light	
P2.4.5	Ventilation	
P2.4.6	Sound insulation	
2.5	Safe movement and access	3,801
P2.5.1	Stairways and ramps	
P2.5.2	Barriers	
P2.5.3	Swimming pools access	

PART 2.0 APPLICATION

2.0 Application

- (a) This Section contains the *Objectives, Functional Statements* and *Performance Requirements* for Class 1 and 10 buildings (other than access requirements for people with disabilities in Class 10 buildings).
- (b) For the purposes of this Section a reference to a building includes a reference to both Class 1 and 10 buildings unless otherwise specified.

Note: Access requirements for people with disabilities in Class 10 buildings are contained in Part D3 of BCA Volume One.

PART 2.1 STRUCTURE

OBJECTIVE

O2.1 The *Objective* is to-

- (a) safeguard people from injury caused by structural failure; and
- (b) safeguard people from loss of amenity caused by structural behaviour; and
- (c) protect *other property* from physical damage caused by structural failure.

FUNCTIONAL STATEMENT

F2.1 A building or structure is to withstand the combination of loads and other actions to which it may be reasonably subjected.

PERFORMANCE REQUIREMENT

P2.1 A building or structure including its materials and components must be capable of sustaining at an acceptable level of safety and serviceability-

- (a) the most adverse combination of loads (including combinations of loads that might result in a potential for progressive collapse); and
 - (b) other actions,
- to which it may reasonably be subjected.

PART 2.2 DAMP AND WEATHERPROOFING

OBJECTIVE

O2.2 The *Objective* is to-

- (a) safeguard occupants from illness or injury and protect the building from damage caused by-
 - (i) *surface water*; and
 - (ii) external moisture entering a building; and
 - (iii) the accumulation of internal moisture in a building; and
 - (iv) the discharge of *swimming pool* waste water; and
- (b) protect *other property* from damage caused by-
 - (i) redirected *surface water*; and
 - (ii) the discharge of *swimming pool* waste water.

STATE AND TERRITORY VARIATIONS

O2.2(a)(iv) and O2.2(b)(ii) do not apply in the Northern Territory.

FUNCTIONAL STATEMENT

F2.2.1 Surface water

A building including any associated *sitework* is to be constructed in a way that protects people and *other property* from the adverse effects of redirected *surface water*.

F2.2.2 Weatherproofing and dampness

A building is to be constructed to provide resistance to moisture from the outside including moisture rising from the ground.

Limitation:

F2.2.2 does not apply to a Class 10 building where in the particular case there is no necessity for compliance.

F2.2.3 Drainage from swimming pools

Adequate means for the disposal of *swimming pool* water and drainage is to be provided to a *swimming pool*.

Note:

The *Housing Provisions* do not contain any *Deemed-to-Satisfy Provisions* for this *Performance Requirement*.

STATE AND TERRITORY VARIATIONS

F2.2.3 does not apply in the Northern Territory.

PERFORMANCE REQUIREMENT**P2.2.1 Surface water**

- (a) *Surface water*, resulting from a storm having an *average recurrence interval* of 10 years and which is collected or concentrated by a building or *sitework*, must be disposed of in a way that avoids the likelihood of damage or nuisance to any *other property*.
- (b) *Surface water*, resulting from a storm having an *average recurrence interval* of 50 years must not enter the building.

Limitation:

P2.2.1(b) does not apply to a Class 10 building where in the particular case there is no necessity for compliance.

- (c) A drainage system for the disposal of *surface water* must-
 - (i) convey *surface water* to an appropriate *outfall*; and
 - (ii) avoid the entry of water into a building; and
 - (iii) avoid water damaging the building.

P2.2.2 Weatherproofing

A roof and *external wall* (including openings around *windows* and doors) must prevent the penetration of water that could cause-

- (a) unhealthy or dangerous conditions, or loss of amenity for occupants; and
- (b) undue dampness or deterioration of building elements.

Limitation:

P2.2.2.(a) does not apply to a Class 10 building where in the particular case there is no necessity for compliance.

P2.2.3 Dampness

Moisture from the ground must be prevented from causing-

- (a) unhealthy or dangerous conditions, or loss of amenity for occupants; and
- (b) undue dampness or deterioration of building elements.

Limitation:

P2.2.3 does not apply to a Class 10 building where in the particular case there is no necessity for compliance.

STATE AND TERRITORY VARIATIONS

P2.2.3 has been replaced in South Australia as follows.

P2.2.3 Dampness

- (a) Moisture from the ground must be prevented from causing-
 - (i) undue dampness or deterioration of building elements; and
 - (ii) unhealthy or dangerous conditions, or loss of amenity for occupants.
- (b) Barriers installed to prevent transfer of moisture from the ground must have-
 - (i) high resistance to moisture penetration; and
 - (ii) high resistance to damage during construction; and
 - (iii) high resistance to degradation by dissolved salts.

P2.2.4 Drainage from swimming pools

A *swimming pool* must have adequate means of draining the pool in a manner which will not-

- (a) cause illness to people; or
- (b) affect *other property*.

Note:

The Housing Provisions do not contain any Deemed-to-Satisfy Provisions for this Performance Requirement.

STATE AND TERRITORY VARIATIONS

P2.2.4 does not apply in the Northern Territory.

PART 2.3 FIRE SAFETY

OBJECTIVE

O2.3 The *Objective* is to-

- (a) safeguard the occupants from illness or injury-
 - (i) by alerting them of a fire in the building so that they may safely evacuate; and
 - (ii) caused by fire from heating appliances installed within the building; and
 - (iii) in *alpine areas*, from an emergency while evacuating the building; and
- (b) avoid the spread of fire; and
- (c) protect a building from the effects of a bushfire.

FUNCTIONAL STATEMENT

F2.3.1 Protection from the spread of fire

A Class 1 building is to be protected from the spread of fire.

F2.3.2 Fire detection and early warning

A Class 1 building is to be provided with safeguards so that occupants are warned of a fire in the building so that they may safely evacuate.

F2.3.3 Heating appliances

Heating appliances using controlled combustion located in a building are to be installed in a way which reduces the likelihood of-

- (a) fire spreading beyond the appliance; and
- (b) smoke from the appliance entering the building.

F2.3.4 Bushfire areas

A Class 1 building constructed in a *designated bushfire prone area* is to provide resistance to bushfires in order to reduce the danger to life and reduce the risk of the loss of the building.

F2.3.5 Alpine areas

A building in an *alpine area* is to be provided with additional measures in view of the increased difficulties in fighting fire and maintaining access and means of egress in snow conditions.

PERFORMANCE REQUIREMENT

P2.3.1 Protection from the spread of fire

- (a) A Class 1 building must be protected from the spread of fire from-
 - (i) another building other than an associated Class 10 building; and
 - (ii) the allotment boundary, other than a boundary adjoining a road or public space.

(see Figure 2.3.1)
- (b) A Class 10a building must not significantly increase the risk of fire spread between Class 2 to 9 buildings.

Amdt 3

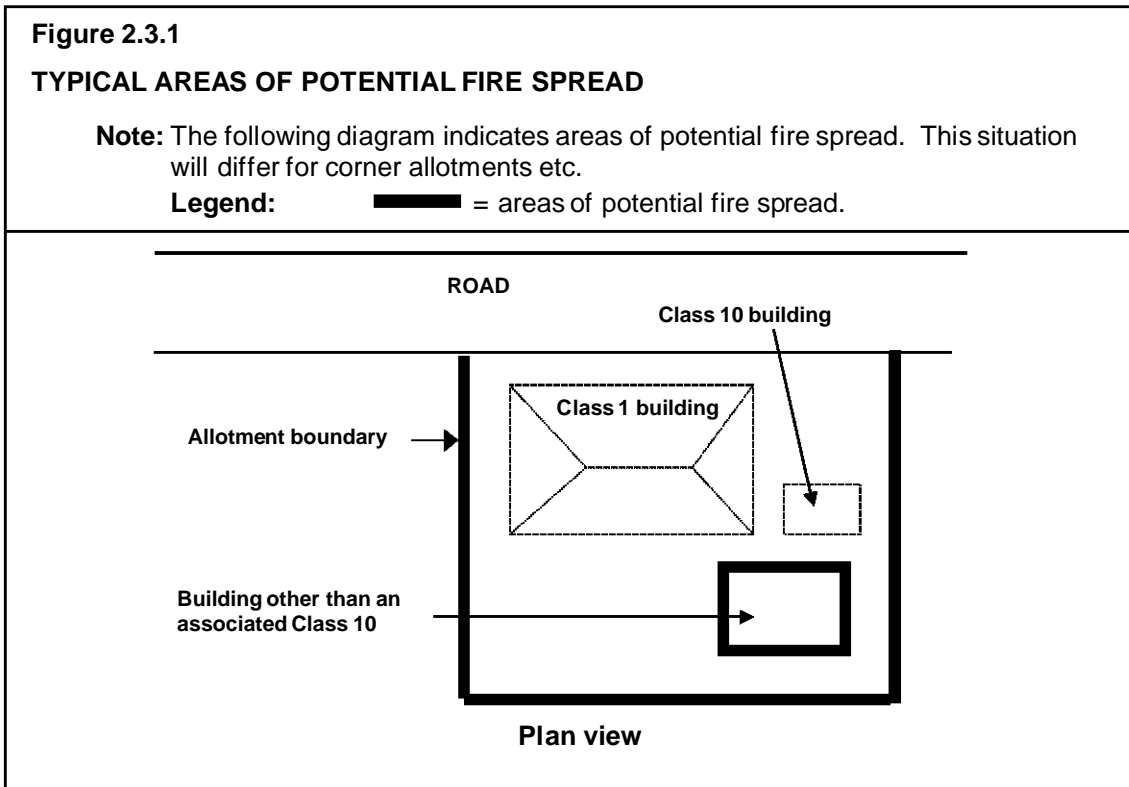

P2.3.2 Fire detection and early warning

In a Class 1 building, occupants must be provided with *automatic* warning on the detection of smoke so that they may evacuate in the event of a fire to a place of safety.

P2.3.3 Heating appliances

A heating appliance and its associated components within a building including an open fire-place, chimney, or the like must be installed-

- (a) to withstand the temperatures likely to be generated by the appliance; and
- (b) so that it does not raise the temperature of any building element to a level that would adversely affect the element's physical or mechanical properties or function; and
- (c) so that hot products of combustion will not-
 - (i) escape through the walls of associated components; and
 - (ii) discharge in a position that will cause fire to spread to nearby *combustible* materials or allow smoke to penetrate through nearby *windows*, ventilation inlets, or the like in the building containing the heating appliance.

P2.3.4 Bushfire areas

A Class 1 building that is constructed in a *designated bushfire prone area* must be provided with protection to reduce the risk of ignition in the event of a bushfire by embers until the fire front passes.

P2.3.5 Alpine areas

- (a) An external doorway from a building in an *alpine area* must be installed so that opening the door is not obstructed by snow or ice.
- (b) A building in an *alpine area* containing external trafficable structures forming part of the means of egress must be constructed so that they remain, as far as practicable, useable under snow conditions.
- (c) A building in an *alpine area* must be constructed so that snow or ice is not shed from the building onto the allotment, any adjoining allotment, road or public space in a location or manner that will-
 - (i) obstruct a means of egress from any building to a road or *open space*;
or
 - (ii) otherwise endanger people.

PART 2.4 HEALTH AND AMENITY

OBJECTIVE

O2.4.1 Wet areas

The *Objective* is to safeguard the occupants from illness or injury and protect the building from damage caused by the accumulation of internal moisture arising from the use of *wet areas* in a building.

O2.4.2 Room heights

The *Objective* is to safeguard the occupants from injury or loss of amenity caused by inadequate height of a room or space.

O2.4.3 Facilities

O2.4.3

Amdt No. 3

The *Objective* is to-

- (a) safeguard occupants from illness caused by infection; and
- (b) safeguard occupants from loss of amenity arising from the absence of adequate personal hygiene facilities; and
- (c) enable occupants to carry out laundering; and
- (d) provide for facilities to enable food preparation; and
- (e) enable unconscious occupants of *sanitary compartments* to be removed from the compartment.

O2.4.4 Light

The *Objective* is to safeguard occupants from injury, illness or loss of amenity due to-

- (a) isolation from natural light; and
- (b) lack of adequate artificial lighting.

O2.4.5 Ventilation

The *Objective* is to safeguard occupants from illness or loss of amenity due to lack of air freshness.

O2.4.6 Sound insulation

The *Objective* is to safeguard occupants from illness or loss of amenity as a result of undue sound being transmitted between adjoining dwellings.

FUNCTIONAL STATEMENT**F2.4.1 Wet areas**

A building is to be constructed to avoid the likelihood of-

- (a) the creation of any unhealthy or dangerous conditions; or
- (b) damage to building elements,

caused by dampness or water overflow from bathrooms, laundries and the like.

F2.4.2 Room heights

A building is to be constructed to provide height in a room or space suitable for the intended use.

F2.4.3 Facilities

A building is to be provided with suitable-

F2.4.3

Amdt No. 3

- (a) space and facilities for personal hygiene; and
- (b) space and facilities for laundering; and
- (c) space and facilities for the preparation and cooking of food; and
- (d) space or other means to permit an unconscious occupant to be removed from a *sanitary compartment*.

Application

F2.4.3 only applies to a Class 1 building.

F2.4.4 Light

- (a) A *habitable room* within a building is to be provided with openings to admit adequate natural light consistent with its function or use; and
- (b) a space within a building used by occupants is to be provided with artificial lighting consistent with its function or use which, when activated in the absence of suitable natural light, will enable safe use and movement.

F2.4.5 Ventilation

A space used by occupants within a building is to be provided with adequate ventilation consistent with its function or use.

F2.4.6 Sound insulation

A building element which separates dwellings is to be constructed to prevent undue sound transmission between those dwellings.

PERFORMANCE REQUIREMENT**P2.4.1 Wet areas**

To protect the structure of the building and to maintain the amenity of the occupants, water must be prevented from penetrating-

- (a) behind fittings and linings; or
 - (b) into concealed spaces,
- of sanitary facilities, bathrooms, laundries and the like.

P2.4.2 Room heights

A room or space must be of a height that does not unduly interfere with its intended function.

P2.4.3 Facilities

P2.4.3
Amdt No. 3

- (a) Suitable sanitary facilities for personal hygiene must be provided in a convenient location within or associated with a building, appropriate to its function or use.
- (b) * * * * *

This clause has been deliberately left blank.

- (c) Laundering facilities or space for laundering facilities must be provided in a convenient location within or associated with a building, appropriate to its function or use.
- (d) A food preparation facility must be provided which includes-
 - (i) a means for food rinsing, utensil washing and waste water disposal; and
 - (ii) a means for cooking food; and
 - (iii) a space for food preparation.
- (e) A sanitary compartment must be constructed with sufficient space or other means to enable an unconscious occupant to be removed from the compartment.

Application:

P2.4.3 only applies to a Class 1 building.

P2.4.4 Light

- (a) A *habitable room* must be provided with *windows* so that natural light, when available, provides a level of *illuminance* appropriate to the function or use of that part of the building.
- (b) Artificial lighting must be installed to provide a level of *illuminance* appropriate to the function or use of the building to enable safe use and movement by occupants.

Application:

P2.4.4(b) only applies-

- (a) to *sanitary compartments*, bathrooms, shower rooms, airlocks, laundries and the like; and
- (b) if natural lighting of a suitable standard is not available.

P2.4.5 Ventilation

- (a) A space within a building used by occupants must be provided with means of ventilation with *outdoor air* which will maintain adequate air quality.
- (b) A mechanical air-handling system installed in a building must control-
 - (i) the circulation of objectionable odours; and
 - (ii) the accumulation of harmful contamination by micro-organisms, pathogens and toxins.
- (c) Contaminated air must be disposed of in a manner which does not unduly create a nuisance or hazard to people in the building or *other property*.

P2.4.6 Sound insulation

- (a) Walls separating dwellings must provide insulation against the transmission of airborne and impact generated sound sufficient to prevent illness or loss of amenity to the occupants.
- (b) The *required* sound insulation of walls must not be compromised by the incorporation or penetration of a pipe or other service element.

PART 2.5 SAFE MOVEMENT AND ACCESS

OBJECTIVE

O2.5 The *Objective* is to-

- (a) provide people with safe access to and within a building; and
- (b) safeguard young children from drowning or injury in a *swimming pool*.

Application:

O2.5 only applies to a *swimming pool* with a depth of water more than 300 mm.

STATE AND TERRITORY VARIATIONS

1. O2.5(b) does not apply in New South Wales.

Note: Restriction of access to swimming pools in New South Wales is regulated under the Swimming Pools Act 1992.

2. O2.5(b) does not apply in the Northern Territory.

3. O2.5(b) does not apply in Queensland.

Note: Restriction of access to swimming pools in Queensland is regulated under the Building Act 1975.

4. O2.5(b) does not apply in Western Australia.

Note: Restriction of access to private swimming pools in Western Australia is regulated under the Local Government (Miscellaneous Provisions) Act 1960 and the Building Regulations 1989 as amended.

FUNCTIONAL STATEMENT

F2.5.1 Safety from falling

A building is to provide safe access for people to the services and facilities within.

F2.5.2 Swimming pool access

A *swimming pool* is to be provided with means to restrict access to it by young children.

Application:

F2.5.2 only applies to a *swimming pool* with a depth of water more than 300 mm.

STATE AND TERRITORY VARIATIONS

1. F2.5.2 does not apply in New South Wales.

Note: Restriction of access to *swimming pools* in New South Wales is regulated under the Swimming Pools Act 1992.

2. F2.5.2 does not apply in the Northern Territory.

3. F2.5.2 does not apply in Queensland.

Note: Restriction of access to *swimming pools* in Queensland is regulated under the Building Act 1975.

4. F2.5.2 does not apply in Western Australia.

Note: Restriction of access to *swimming pools* in Western Australia is regulated under the Local Government (Miscellaneous Provisions) Act 1960 and the Building Regulations 1989 as amended.

Amdt 3

PERFORMANCE REQUIREMENT

P2.5.1 Stairways and ramps

So that people can move safely to and within a building-

- (a) walking surfaces must have safe gradients; and
- (b) any stairway or ramp must-

P2.5.1(b)(i)
Amdt No. 3

- (i) * * * * *

This clause has been deliberately left blank.

- (ii) have suitable landings to avoid undue fatigue of users; and
- (iii) be suitable for safe passage in relation to the nature, volume and frequency of likely usage; and
- (iv) have slip-resistant walking surfaces on ramps, and on stairway treads or near the edge of the nosing.

P2.5.2 Barriers

Where people could fall 1 m or more-

P2.5.2
Amdt No. 3

- (a) from a floor or roof of a building or through an opening (other than through an openable *window*) in the *external wall*; or
- (b) due to a sudden change of level within or associated with a building, a barrier must be provided which must be-
- (c) continuous and extend for the full extent of the hazard; and

- (d) of a height to protect people from accidentally falling from the floor or roof or through the opening; and
- (e) constructed to prevent people from falling through the barrier; and
- (c) capable of restricting the passage of children; and
- (d) of strength and rigidity to withstand-
 - (i) the foreseeable impact of people; and
 - (ii) where appropriate, the static pressure of people pressing against it.

P2.5.3 Swimming pool access

A barrier must be provided to a *swimming pool* and must-

- (a) be continuous for the full extent of the hazard; and
- (b) be of a strength and rigidity to withstand the foreseeable impact of people; and
- (c) restrict the access of young children to the pool and the immediate pool surrounds; and
- (d) have any gates and doors fitted with latching devices not readily operated by young children, and constructed to automatically close and latch.

Application:

P2.5.3 only applies to a *swimming pool* with a depth of water more than 300 mm.

STATE AND TERRITORY VARIATIONS

1. **P2.5.3 does not apply in New South Wales.**
Note: Restriction of access to *swimming pools* in New South Wales is regulated under the Swimming Pools Act 1992.
2. **P2.5.3 does not apply in the Northern Territory.**
3. **P2.5.3 does not apply in Queensland.**
Note: Restriction of access to *swimming pools* in Queensland is regulated under the Building Act 1975.
4. **P2.5.3 does not apply in Western Australia.**
Note: Restriction of access to *swimming pools* in Western Australia is regulated under the Local Government (Miscellaneous Provisions) Act 1960 and the Building Regulations 1989 as amended.

SECTION **3**

Amdt 3

ACCEPTABLE CONSTRUCTION

Introduction

The scope of these provisions

Suitability of Alternative Solutions

The use of maps

Consultation with appropriate authorities

Layout of Parts 3.1 - 3.11

How to use the requirements of each Part

SECTION 3 CONTENTS

	Page
SECTION 3 - ACCEPTABLE CONSTRUCTION	
How to Use	4,031
Introduction	
The scope of these provisions	
Suitability of Alternative Solutions	
The use of maps	
Consultation with appropriate authorities	
Layout of Parts 3.1 - 3.11	
How to use the requirements of each Part	
3.1 Site preparation	
3.1.1 Earthworks	5,021
3.1.1.0 Application	
3.1.1.1 Earthworks	
3.1.1.2 Excavation adjacent to vacant adjoining property	
3.1.1.3 Excavation adjacent to existing buildings	
3.1.1.4 Fill	
3.1.2 Drainage	5,201
3.1.2.0 Acceptable construction manual	
3.1.2.1 Application	
3.1.2.2 Drainage requirements	
3.1.2.3 Surface water drainage	
3.1.2.4 Subsoil drainage	
3.1.2.5 Stormwater drainage	
3.1.3 Termite risk management	
3.1 Definitions	
3.1.3 Application of this Part	5,801
3.1.3.0 Acceptable construction manual	
3.1.3.1 Application	
3.1.3.2 Installation of termite barriers	
3.1.3.3 Barriers for concrete slab-on-ground	
3.1.3.4 Protection of suspended floors	
Explanatory information - Termites	

Continued

Amdt 3

	Page
Continued	
3.2 Footings and slabs	7,021
3.2 Definitions	
3.2.0 Acceptable construction manuals	
3.2.1 Application	
3.2.2 Preparation	7,201
3.2.2.1 Excavation for footings	
3.2.2.2 Filling under concrete slabs	
3.2.2.3 Foundations for footings and slabs	
3.2.2.4 Slab edge support on sloping sites	
3.2.3.5 Stepped footings	
3.2.2.6 Vapour barriers	
3.2.2.7 Edge rebates	
3.2.3 Concrete and reinforcing	7,401
3.2.3.1 Concrete	
3.2.3.2 Steel reinforcement	
3.2.4 Site classification	7,601
3.2.4.1 Site classification	
3.2.5 Footing and slab construction	7,801
3.2.5.1 Footing and slab construction	
3.2.5.2 Footings and slabs to extensions to existing buildings	
3.2.5.3 Shrinkage control	
3.2.5.4 Minimum edge beam dimensions	
3.2.5.5 Footings for fireplaces on Class A and S sites	
3.2.5.6 Stump footing details	
3.3 Masonry	
3.3 Definitions	9,012
3.3.1 Unreinforced masonry	9,021
3.3.1.0 Acceptable construction manual	
3.3.1.1 Application	
3.3.1.2 External walls	
3.3.1.3 Internal walls	
3.3.1.4 Isolated piers	
3.3.1.5 Masonry units	
3.3.1.6 Mortar mixes	
Continued.	

SECTION 3 CONTENTS

	Page
Continued	
3.3.1.7 Mortar joints	
3.3.1.8 Vertical articulation joints	
3.3.1.9 Sub-floor ventilation	
3.3.1.10 Shrinkage allowance for timber framing	
3.3.2 Reinforced masonry	9,301
3.3.2.0 Acceptable construction manual	
3.3.2.1 Application	
3.3.2.2 External wall construction	
3.3.3 Masonry accessories	9,601
3.3.3.0 Acceptable construction manual	
3.3.3.1 Application	
3.3.3.2 Wall ties	
3.3.3.3 Fixing straps and tie down systems	
3.3.3.4 Lintels	
3.3.4 Weatherproofing	9,801
3.3.4 Definitions	
3.3.4.0 Acceptable construction manual	
3.3.4.1 Application	
3.3.4.2 Width of cavity	
3.3.4.3 Cavity ventilation and drainage	
3.3.4.4 Damp proof courses - materials	
3.3.4.5 Damp proof courses - installation	
3.3.4.6 Flashings	
3.3.4.7 Weatherproofing for single skin masonry walls	
3.3.5 Earthwall construction	10,101
3.3.5 Definitions	
3.3.5.0 Acceptable construction manual	
3.3.5.1 Application	
3.3.5.2 General construction	
3.3.5.3 Minimum thickness of walls	
3.3.5.4 Weatherproofing	
3.4. Framing	
3.4.0 Explanation of terms	11,051
3.4.1 Sub-floor ventilation	11,101
3.4.1.1 Application	
3.4.1.2 Sub-floor ventilation	
Continued.	

	Page
Continued	
3.4.2. Steel framing	11,301
3.4.2.0 Acceptable construction manuals	
3.4.2.1 Application	
3.4.2.2 General	
3.4.2.3 Steel floor framing	
3.4.2.4 Steel wall framing	
3.4.2.5 Steel roof framing	
3.4.2.6 Installation of services	
3.4.3 Timber framing	11,601
3.4.3.0 Acceptable construction manuals	
3.4.3.1 Application	
3.4.3.2 Materials	
3.4.3.3 Floor framing	
3.4.3.4 Flooring	
3.4.3.5 Wall framing	
3.4.3.6 Conventional roofs	
3.4.3.7 Acceptable timber frame sizes and fixing	
3.4.3.8 Bracing of timber frames	
3.4.4 Structural steel members	12,201
3.4.4 Explanation of terms	
3.4.4.0 Acceptable construction manuals	
3.4.4.1 Application	
3.4.4.2 Structural steel members	
3.4.4.3 Columns	
3.4.4.4 Corrosion protection	
3.5 Roof and wall cladding	
3.5.1 Roof cladding	13,021
3.5.1.0 Acceptable construction manuals	
3.5.1.1 Application	
3.5.1.2 Roof tiling	
3.5.1.3 Metal sheet roofing	
3.5.2 Gutters and downpipes	13,301
3.5.2.0 Acceptable construction manuals	
3.5.2.1 Application	
3.5.2.2 Materials	
Continued.	

SECTION 3 CONTENTS

	Page
Continued	
3.5.2.3 Selection of guttering	
3.5.2.4 Installation of gutters	
3.5.2.5 Downpipes - size and installation	
3.5.3 Wall cladding	13,501
3.5.3.1 Application	
3.5.3.2 Timber weatherboard cladding	
3.5.3.3 Fibre cement planks and weatherboard cladding	
3.5.3.4 Sheet wall cladding	
3.5.3.5 Eaves and soffit lining	
3.5.3.6 Flashings to wall openings	
3.6. Glazing	15,021
3.6 Definitions	
3.6.0 Acceptable construction manual	
3.6.1 Application	
3.6.2 Glazing sizes and installation	
3.6.3 Perimeter framed glazing	
3.6.4 Human impact safety requirements	
3.6.5 Doors	
3.6.6 Side panels	
3.6.7 Full height framed glazed panels	
3.6.8 Glazed panels, other than doors or side panels, on the perimeter of rooms	
3.6.9 Shower doors, shower screens and bath enclosures	
3.7 Fire safety	
3.7.1 Fire separation	17,021
3.7.1.1 Application	
3.7.1.2 General concession - non combustible materials	
3.7.1.3 External walls of Class 1 buildings	
3.7.1.4 Measurement of distances	
3.7.1.5 Construction of external walls	
3.7.1.6 Class 10a buildings	
3.7.1.7 Allowable encroachments	
3.7.1.8 Separating walls	
3.7.1.9 Sarking type materials	
3.7.1.10 Roof lights	
Continued.	

	Page
Continued	
3.7.2 Smoke alarms	17,301
3.7.2.1 Application	
3.7.2.2 Requirements for smoke alarms	
3.7.2.3 Location - Class 1a buildings	
3.7.2.4 Location - Class 1b buildings	
3.7.2.5 Lighting to assist evacuation – Class 1b buildings	
Explanatory information - Smoke alarms	
3.7.3 Heating appliances	17,501
3.7.3.0 Acceptable construction manuals	
3.7.3.1 Application	
3.7.3.2 Open fireplace construction	
3.7.3.3 Chimney construction	
3.7.3.4 Installation of insert fireplaces and flues	
3.7.3.5 Installation of free standing heating appliances	
3.7.4 Bushfire areas	17,701
3.7.4.0 Acceptable construction manuals	
3.7.4.1 Application	
3.7.4.2 Bushfire protection	
3.7.5 Alpine areas	17,901
3.7.5.1 Application	
3.7.5.2 External doorways	
3.7.5.3 External ramps	
3.7.5.4 Discharge of external doorways providing a means of egress	
3.7.5.5 External trafficable structures	
3.8 Health and amenity	
3.8.1 Wet areas	19,021
3.8.1 Definitions	
3.8.1.0 Acceptable construction manual	
3.8.1.1 Application	
3.8.1.2 Wet areas	
3.8.1.3 Materials - general	
3.8.1.4 Protection of shower floors in wet areas	
3.8.1.5 Protection of walls in wet areas	
3.8.1.6 Sealing of wall and floor junctions and joints	
	Continued.

SECTION 3 CONTENTS

	Page
Continued	
3.8.2 Room heights	19,301
3.8.2.1 Application	
3.8.2.2 Ceiling heights	
3.8.3 Facilities	19,501
3.8.3.1 Application	
3.8.3.2 Required facilities	
3.8.3.3 Construction of sanitary compartments	
3.8.4 Light	19,701
3.8.4.1 Application	
3.8.4.2 Natural lighting	
3.8.4.3 Artificial lighting	
3.8.5 Ventilation	19,901
3.8.5.0 Acceptable construction manual	
3.8.5.1 Application	
3.8.5.2 Ventilation requirements	
3.8.5.3 Location of sanitary compartments	
3.8.6 Sound insulation	20,101
3.8.6.1 Application	
3.8.6.2 Sound insulation requirements	
3.8.6.3 General installation requirements for walls	
3.8.6.4 Soil and waste pipes	
3.9 Safe movement and access	
3.9.1 Stair construction	21,021
3.9.1 Definitions	
3.9.1.1 Application	
3.9.1.2 General requirements	
3.9.1.3 Stair construction	
3.9.1.4 Riser and going dimensions	
3.9.1.5 Thresholds	
3.9.2 Balustrades	21,201
3.9.2.1 Application	
3.9.2.2 When balustrades or other barriers are required	
3.9.2.3 Balustrade or other barrier construction	
	Continued.

Amdt 3

	Page
Continued	
3.9.3 Swimming pool access	21,401
3.9.3.0 Acceptable construction manual	
3.9.3.1 Application	
3.9.3.2 Safety fencing location and construction	
3.10 Additional construction requirements	
3.10.1 High wind areas	23,021
3.10.1.0 Acceptable construction manuals	
3.10.2 Earthquake areas	23,201
3.10.2 Definitions	
3.10.2.0 Acceptable construction manual	
3.10.2.1 Application	
3.10.2.2 Construction requirements	
3.10.2.3 Construction for areas with an acceleration coefficient of 0.12 or more but less than 0.15	
3.10.2.4 Construction for areas with an acceleration coefficient of 0.15 or more	
3.11 Structural design manuals	
3.11 Acceptable construction manuals	25,021
3.11.1 Application	
3.11.2 Acceptable structural design manuals	
3.11.3 Loading requirements	
3.11.4 Structural design manuals	

HOW TO USE SECTION 3

Explanatory information:

This is a non mandatory guide on how to use Section 3 of the *Housing Provisions*.

3.1 Introduction

Section 3, Parts 3.1- 3.11 are *Deemed-to-Satisfy Provisions* that are considered to be acceptable forms of construction that meet the legislative requirements for complying with the *Housing Provisions* (ie they comply with the *Performance Requirements* listed in Section 2 of the *Housing Provisions*).

There is no obligation to adopt any particular option contained in Section 3 of the *Housing Provisions*, if it is preferred to meet the *Performance Requirement* in some other way.

However, if one of the options described in Section 3 is not complied with, then the *appropriate authority* must be satisfied that the *Performance Requirements* have been met.

3.2 The scope of these provisions

The *Deemed-to-Satisfy Provisions* (described as “acceptable construction practice” or “acceptable construction manuals”) are indicative of some of the most common forms of national construction practice.

However, it should be noted that some of these options described as “acceptable construction practice” may have very specific limitations and accordingly will not be suitable for all applications. Generally these limitations relate to climatic (*design wind speed*), geographical and topographical conditions and building geometry.

If the acceptable construction practice option is not suitable for the proposed construction or *site* conditions, an alternative approach may be found in one of the acceptable construction manuals listed at the start of each Part. Similarly, if a particular building element or component *required* to comply with the *Housing Provisions* is not contained in the acceptable construction practice, reference will need to be made to the appropriate acceptable construction manual or Part 3.11.

3.3 Suitability of Alternative Solutions

The options described in Section 3 are typical examples. They are certainly not the only means available of complying with the *Housing Provisions*. The performance nature of this document provides flexibility and allows the use of alternative construction methods even though they may not be specifically described in an acceptable construction manual or as acceptable construction practice.

Alternative Solutions may be used provided they comply with the *Performance Requirements* listed in Section 2 (for further explanation see Part 1.0).

3.4 The use of maps

Maps have been used throughout Section 3 to indicate areas where particular requirements apply. These maps are indicative and some variation in conditions will apply, especially on the border of marked areas.

It is recommended that the *appropriate authority* be consulted as in most cases they may be able to identify what conditions apply in such areas at the early stage of building design.

3.5 Consultation with appropriate authorities

When building in certain locations there may be local conditions that may limit the type of construction that can be used. This is particularly important with *design wind speed* classifications and soil types.

Appropriate authorities have a wide range of experience and information on the geographical and topographical conditions found in their area of responsibility, and should be consulted during the initial design stage.

3.6 Layout of Parts 3.1- 3.11

Parts 3.1- 3.11 of the *Housing Provisions* are organised in a manner that follows the logical construction sequence of a building. The following chart outlines some of the more frequently used details and where it is located in this document.

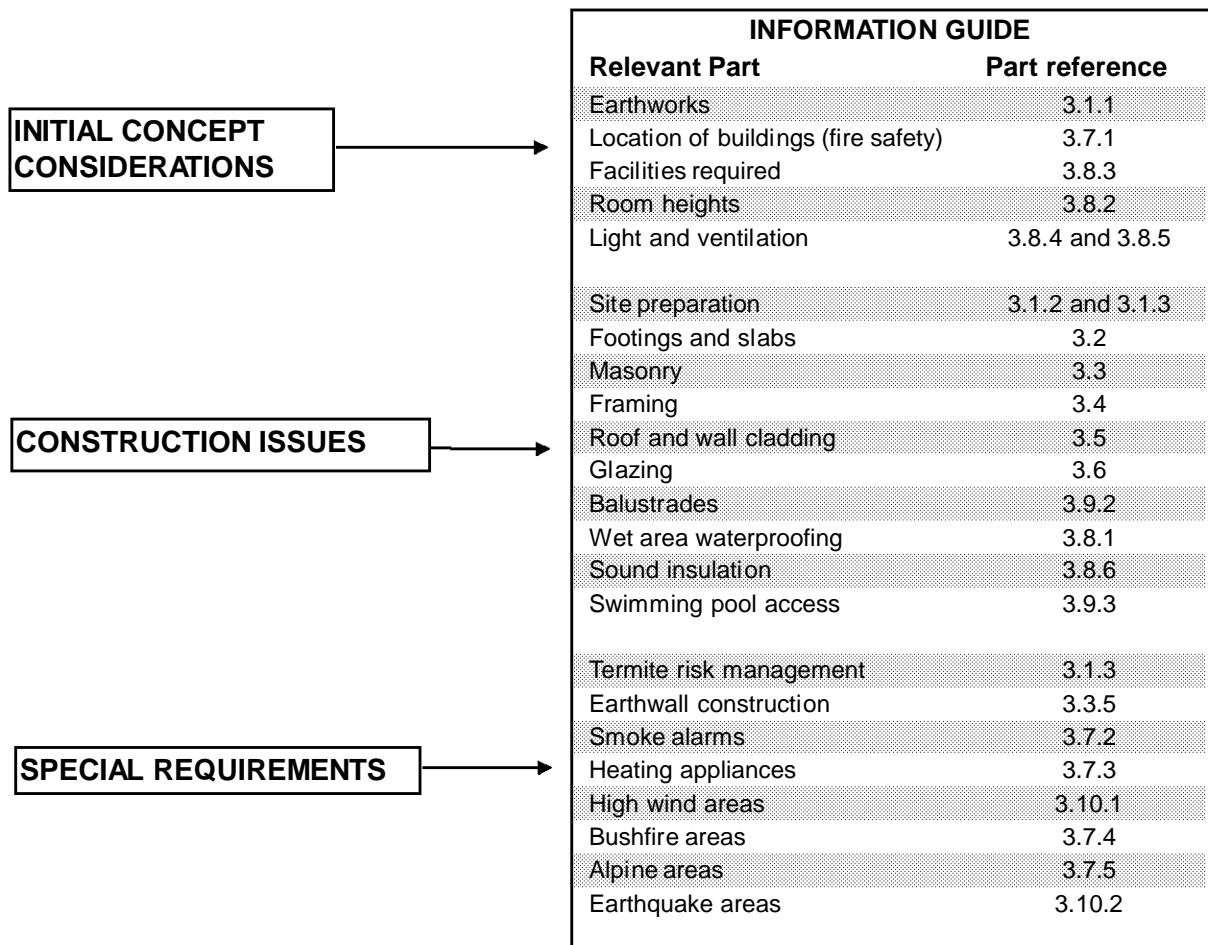

3.7 How to use the requirements of each Part

The following is an example of a page layout from Part 3.2. This diagram explains the concepts behind typical clauses contained throughout Parts 3.1 to 3.11.

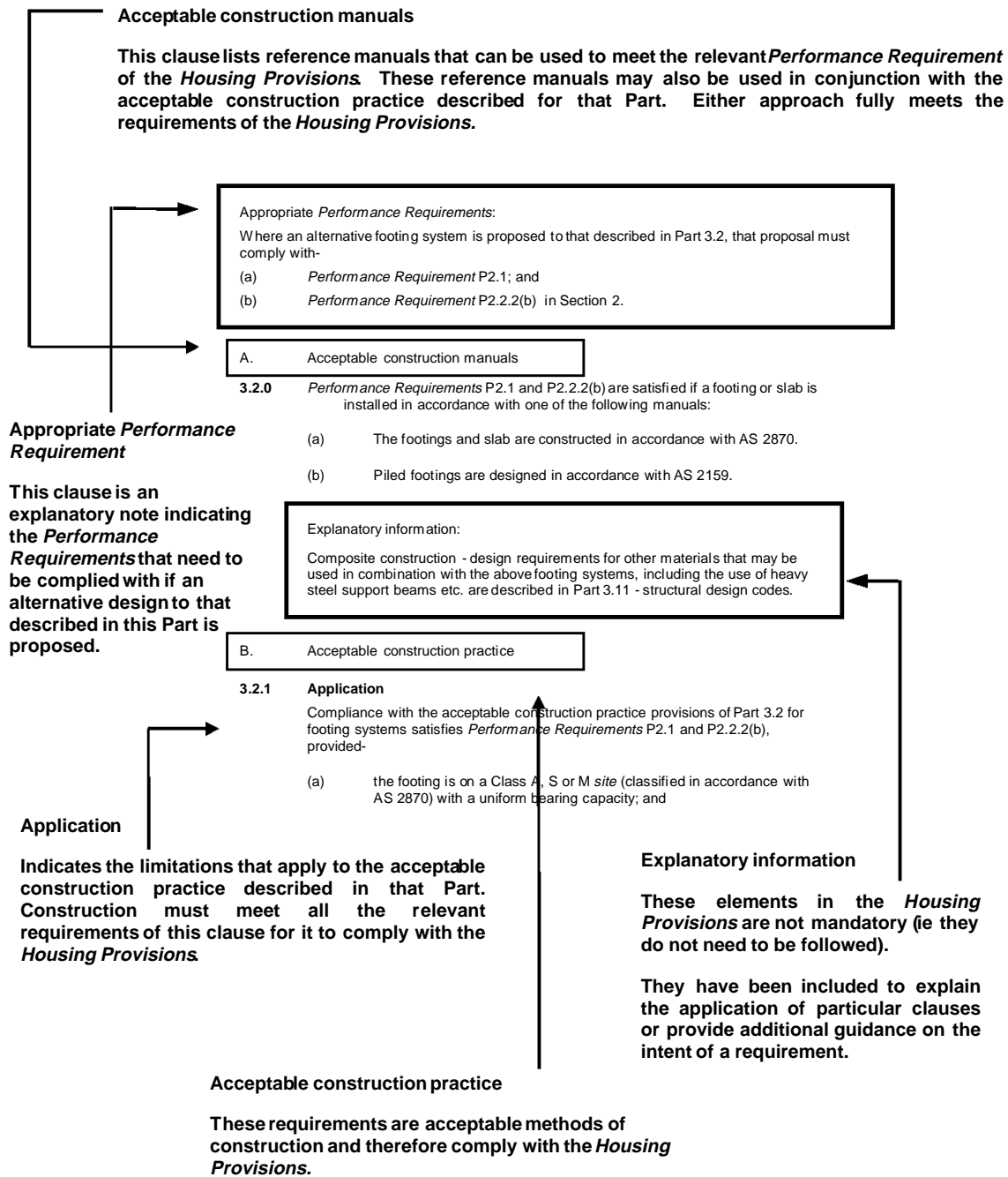

Amdt 3

PART **3.1**

Amdt 3

SITE PREPARATION

3.1.1 Earthworks

3.1.2 Drainage

3.1.3 Termite risk management

PART 3.1 CONTENTS

	Page
3.1.1 Earthworks	5,021
3.1.1.0 Application	
3.1.1.1 Earthworks	
3.1.1.2 Excavation adjacent vacant adjoining property	
3.1.1.3 Excavation adjacent existing buildings	
3.1.1.4 Fill	
3.1.2 Drainage	5,201
3.1.2.0 Acceptable construction manual	
3.1.2.1 Application	
3.1.2.2 Drainage requirements	
3.1.2.3 Surface water drainage	
3.1.2.4 Subsoil drainage	
3.1.2.5 Stormwater drainage	
3.1.3 Termite risk management	5,801
3.1.3 Application of this Part	
3.1.3.0 Acceptable construction manual	
3.1.3.1 Application	
3.1.3.2 Installation of termite barriers	
3.1.3.3 Barriers for concrete slab-on-ground	
3.1.3.4 Protection of suspended floors	
Explanatory information - Termites	

Explanatory Information:

These provisions relate to general *site* preparation for footings, services, drainage and installation of termite barriers to assist in termite management.

It should be noted that other construction methods may be used to achieve the same results as specified in this Part provided they comply with the appropriate *Performance Requirement*.

PART 3.1.1 EARTHWORKS

Appropriate Performance Requirements:

Where an alternative approach to earthworks is proposed to that described in Part 3.1.1, that proposal must comply with *Performance Requirement P2.1* in Section 2.

NSW Var.
Amdt No. 3

STATE AND TERRITORY VARIATIONS

Except for Table 3.1.1.1 as referenced by Figures 3.1.2.1 and 3.1.2.2, and except for clause 3.1.1.0(b) for determination of a normal site as referenced by clause 3.2.1, Part 3.1.1 does not apply in New South Wales.

Note: In New South Wales the Local Government Act 1993 and the Local Government (Approvals) Regulation 1993 regulate matters relating to siteworks associated with the erection of a building including, the safeguarding of excavations and backfilling, provision of retaining walls to prevent soil movement, and support for neighbouring buildings.

Amdt 3

Acceptable construction practice

3.1.1.0 Application

Compliance with this Part satisfies *Performance Requirement P2.1* for earthworks provided:

- (a) The work is undertaken in normal *site* conditions.
- (b) For the purposes of this Part, normal *site* conditions are defined by the following parameters -
 - (i) a *site* that is classified as A, S, M, H or E in accordance with Part 3.2; and
 - (ii) moisture conditions on *site* are as a result of seasonal and climatic changes; and
 - (iii) the *site* is not subject to unusual moisture conditions caused by drains, dams, channels, ponds or tanks which are maintained or removed from the *site*; and
 - (iv) large trees have not been recently removed from the *site*; and
 - (v) soil moisture conditions have not been significantly modified by the removal of buildings or other structures; and
 - (vi) drainage on the allotment is maintained.

Explanatory Information:

The provisions described in Part 3.1.1 will enable earthworks to be carried out safely and avoid potential damage to adjoining structures and property through the soil collapsing or subsiding during building works. Exceptional *site* conditions (including the effects of torrential rain) may need special consideration and additional advice from appropriately qualified people should be considered.

State and Territory legislation may also have requirements that affect the excavation, especially in relation to adjoining property and notification to owners of that property. Advice should be obtained from the *appropriate authority* before commencement of works.

3.1.1.1 Earthworks

Excavation and fill utilising unprotected embankments can be undertaken in accordance with-

- (a) Table 3.1.1.1 for general earthwork; or
- (b) 3.1.1.2 for excavation adjacent to vacant adjoining property; or
- (c) 3.1.1.3 for excavation adjacent to existing buildings; or
- (d) 3.1.1.4 for fill adjacent to adjoining property.

3.1.1.2 Excavation adjacent to vacant adjoining property

Excavation work, using unprotected embankments, adjacent to another allotment can be undertaken provided -

- (a) there are no buildings or structures on the adjoining allotment within 3 m of the allotment boundary adjacent to the excavation; and
- (b) the excavation commences at the allotment boundary and is within the area defined as being suitable for excavation in Figure 3.1.1.1; and
- (c) the slope of the unprotected embankment of the excavation complies with the appropriate soil classification slope described in Table 3.1.1.1.

3.1.1.3 Excavation adjacent to existing buildings

Excavation work for footings, drainage trenches or other similar works, adjacent to existing buildings can be undertaken provided -

- (a) the angle to determine the safe area for excavation is taken from the bottom of the shallowest point of the existing footing in accordance with Figure 3.1.1.2; and
- (b) the excavation is within the area defined as being suitable for excavation in Figure 3.1.1.2; and
- (c) the slope of the unprotected embankment of the excavation complies with the appropriate soil classification described in Table 3.1.1.1; and
- (d) for footing excavation adjacent to existing footings -

- (i) the footing is placed as soon as practicable after exposing the existing footing; and
- (ii) the existing footing, where on an adjoining property, is completely isolated from the new footing by means of a flexible bond breaker not less than 10 mm thick; and
- (e) the adjoining footing is not left exposed at the completion of works.

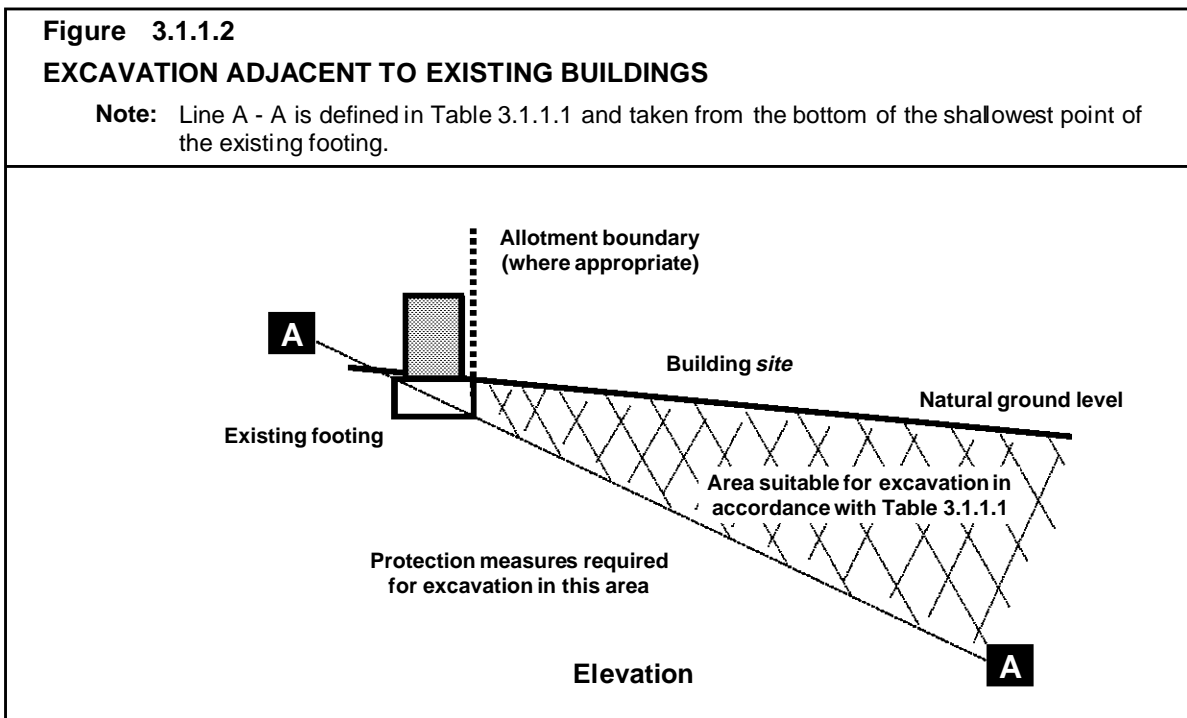
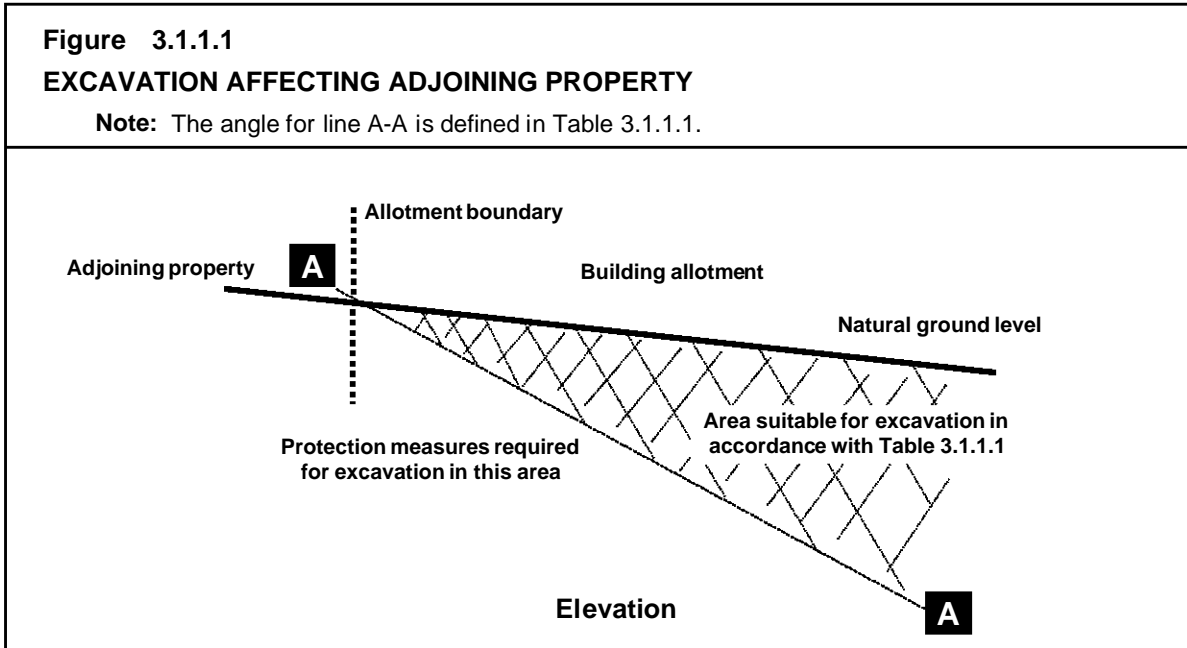

Amdt 3

3.1.1.4 Fill

Filling works may be carried out provided-

- (a) where the fill is deeper than existing soil level, the gradient of the fill complies with Table 3.1.1.1; and
- (b) where the fill is to be used to support footings or slabs, it is placed and compacted in accordance with Part 3.2.

Table 3.1.1.1
Amdt No. 2

Table 3.1.1.1 UNPROTECTED EMBANKMENTS		
<p>Notes: For the purposes of this Table:</p> <ol style="list-style-type: none"> Retaining walls or other types of soil retaining methods must be installed where - <ul style="list-style-type: none"> (a) the slope ratio is more than that described in Table 3.1.1.1; or (b) the soil type is not described in this Table. Embankments that are to be left exposed at the end of the construction works must be stabilised by vegetation or similar works to prevent soil erosion. 		
<p style="text-align: center;">Elevation</p>		
SOIL TYPE (*see Part 3.2.4 for material description)	EMBANKMENT SLOPES H:L	
	Compacted fill (see Part 3.2)	Cut
Stable rock (A*)	2:3	8:1
Sand (A*)	1:2	2:3
Silt (P*)	1:4	1:4
Clay	Firm clay	1:2
	Soft clay	Not suitable
Soft soils (P*)	Not suitable	Not suitable

Amdt 3

PART 3.1.2 DRAINAGE

Appropriate *Performance Requirements*:

Where an alternative drainage system is proposed to that described in Part 3.1.2, that proposal must comply with *Performance Requirement P2.2.1* in Section 2.

A. Acceptable construction manual

3.1.2.0 Acceptable construction manual

3.1.2.0
Amdt No. 3

Performance Requirement P2.2.1 is satisfied for drainage if the drainage is designed and constructed in accordance with AS/NZS 3500.3.2 - Stormwater drainage.

B. Acceptable construction practice

3.1.2.1 Application

Compliance with this Part satisfies *Performance Requirement P2.2.1* for drainage of-

- (a) roofs in areas subject to 5 minute duration rainfall intensities of not more than 255 mm per hour over an *average recurrence interval* of 20 years (as per Table 3.5.2.1) where a drainage system is *required*; and
- (b) sub-soil areas where excessive soil moisture problems may occur; and
- (c) land adjoining and under buildings,

3.1.2.1
Amdt No. 3

provided the stormwater drainage system otherwise complies with AS/NZS 3500.3.2.

Explanatory Information:

1. The BCA does not require the installation of drainage systems. Accordingly these requirements need only be applied when these systems are used.
2. Information on the need for drainage systems may be obtained from the *appropriate authority*.
3. The legal discharge point from a building *site* is generally determined by local government authorities.

3.1.2.2 Drainage requirements

Drainage systems must be installed as follows-

- (a) areas adjoining and under buildings - *surface water* drainage in accordance with 3.1.2.3; and
- (b) where *site* conditions exist that create a need for subsoil water to be diverted away from footings, basements, retaining walls etc - sub-soil drainage in accordance with 3.1.2.4; and
- (c) where underground drainage from roof areas is *required* or permitted - underground stormwater drainage in accordance with 3.1.2.5; and
- (d) excavation for drains adjacent to existing footings must be within the area described in Figure 3.1.2.1 as being safe for excavation.

Figure 3.1.2.1

EXCAVATION FOR DRAINS ADJACENT TO FOOTINGS

Note: Any excavation below the area defined as being safe for excavation will need additional protection measures to be determined by appropriately qualified persons.

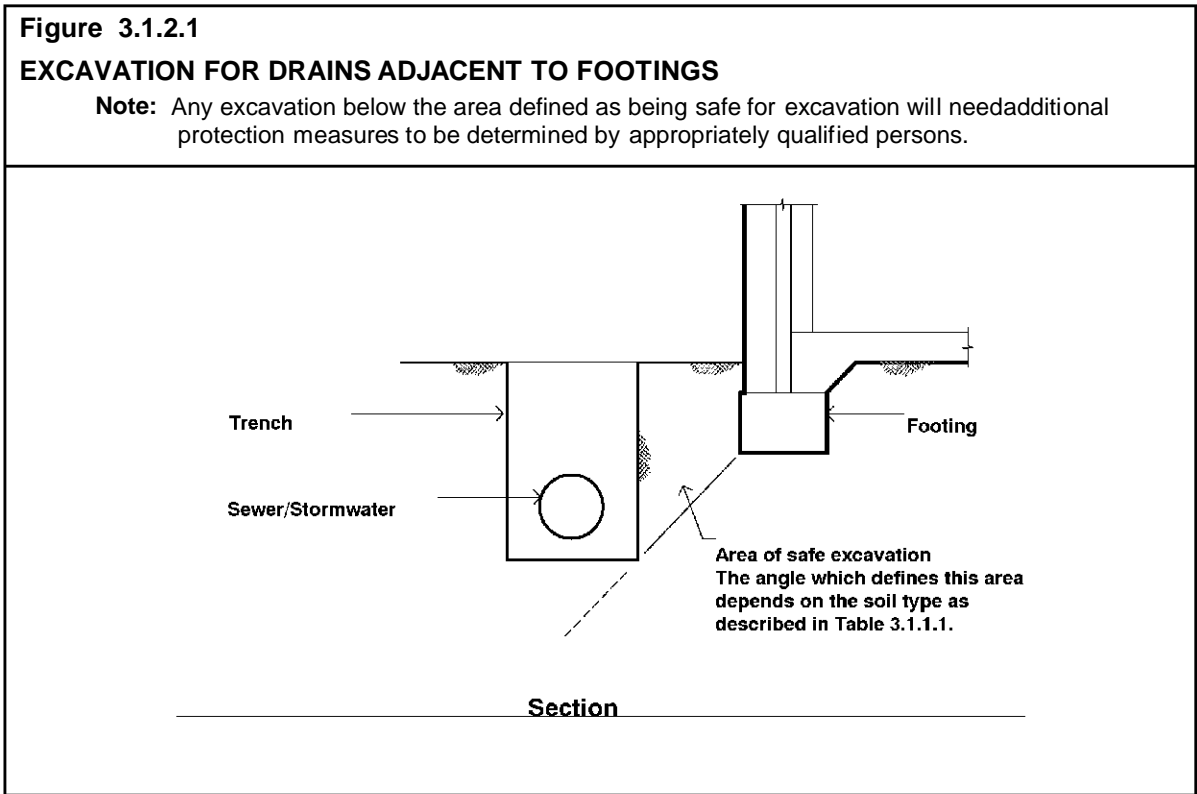

3.1.2.3 Surface water drainage

Surface water must be diverted away from Class 1 buildings as follows:

- (a) Slab-on-ground - finished ground level adjacent to buildings
The external finished surface surrounding the slab must be drained to move *surface water* away from the building and graded to give a slope of not less than 50 mm over the first 1m from the building (see Figure 3.1.2.2).
- (b) Slab-on-ground - finished slab heights
The height of the slab-on-ground (measured at the slab edge) above external finished surfaces must be not less than-
 - (i) 150 mm above finished ground level; or
 - (ii) 100 mm above sandy, well-drained areas; or
 - (iii) 50 mm above paved or concreted areas that slope away from the building in accordance with (a).

Explanatory Information:

The appropriate slab height above finished ground level may vary depending on:

1. The local plumbing requirements; in particular the height of the overflow relief gully relative to drainage fittings and ground level (to work effectively they must be a minimum of 150 mm below the lowest sanitary fixture).
2. The run-off from storms and the local topography.
3. The effect of excavation on a cut and fill *site*.
4. The possibility of flooding.
5. Termite barrier provisions.

- (c) The ground beneath suspended floors must be graded so that the area beneath the building is above the adjacent external finished ground level and *surface water* is prevented from ponding under the building (see Figure 3.1.2.3).

Figure 3.1.2.2
SITE SURFACE DRAINAGE

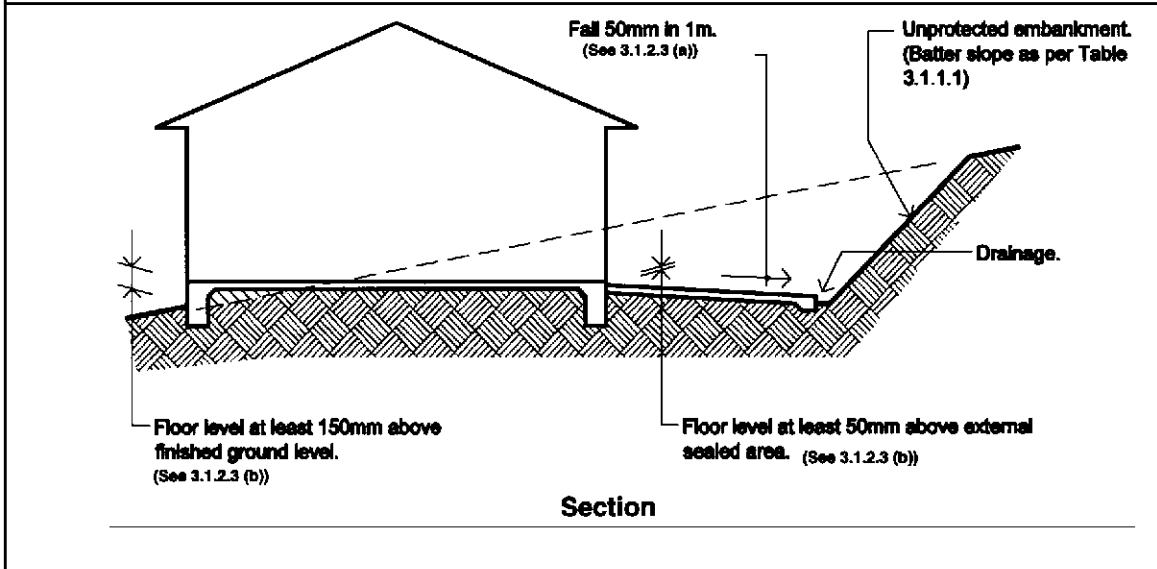

Amdt 3

Figure 3.1.2.3
GRADING OF GROUND UNDER SUSPENDED FLOORS

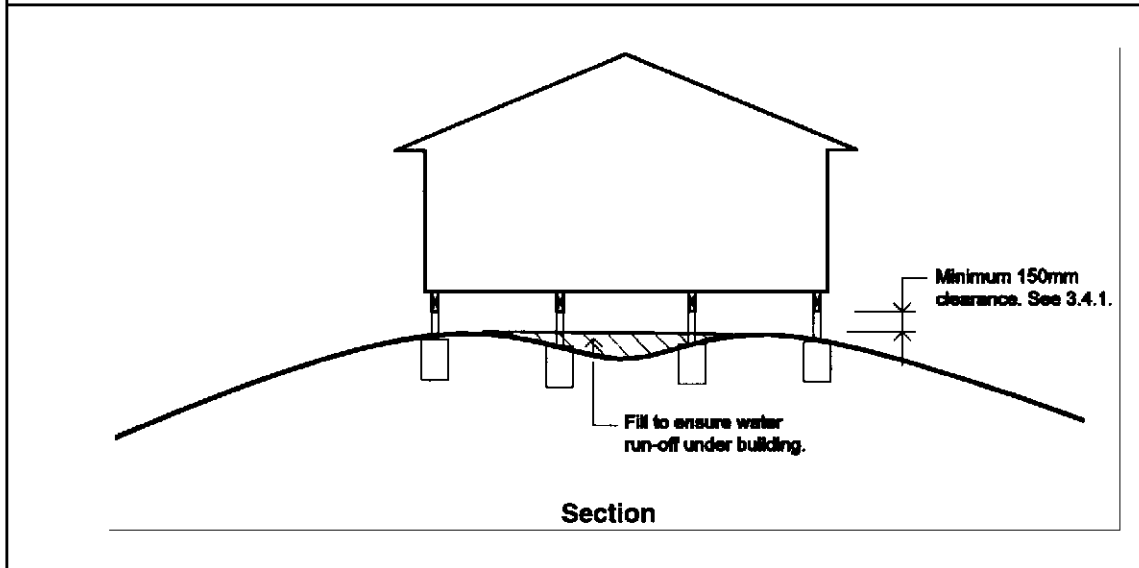

3.1.2.4 Subsoil drainage

Where a subsoil drainage system is installed to divert sub-surface water away from the area beneath the building it must comply with the following:

Explanatory Information:

Subsoil drainage may need to be installed where subsoil water movement could damage buildings through the build up of excessive moisture or lateral water pressure on footings.

- (a) The depth to the top of the drain must not be less than 400 mm into the soil; and not less than 100 mm below any adjacent-
 - (i) pavement level; and
 - (ii) footing base.
- (b) Trench bases (as appropriate) must be graded to a uniform fall to suit the following-
 - (i) parallel with pavement grade; and
 - (ii) parallel with overall grade of footings; and
 - (iii) not less than 1:300.
- (c) The bottom of the trench must be well compacted and evenly graded.
- (d) The drain must be laid true to line and gradient on the bottom of the trench or where rock is encountered, on compacted bedding.
- (e) Silt pits or sumps of a suitable size for expected water flow, must be provided at the outlet end of each subsoil drain before it discharges into an impervious drainage line.

Explanatory Information:

Silt pits designed to control the amount of silt entering the drainage system are usually installed where the excavation on a *site* exceeds 1 m and there is a need to drain subsoil water movement.

Silt pits are typically prefabricated and designed to suit a range of conditions. Heavy duty silt pits are not commonly used in domestic applications except in areas subject to traffic (such as where a driveway runs down towards a garage located under a dwelling).

To be effective the silt pit must be maintained by regular cleaning.

- (f) Outlets must be installed through walls of silt pits not less than 50 mm below the lowest point of the inlet (see Figure 3.1.2.4).

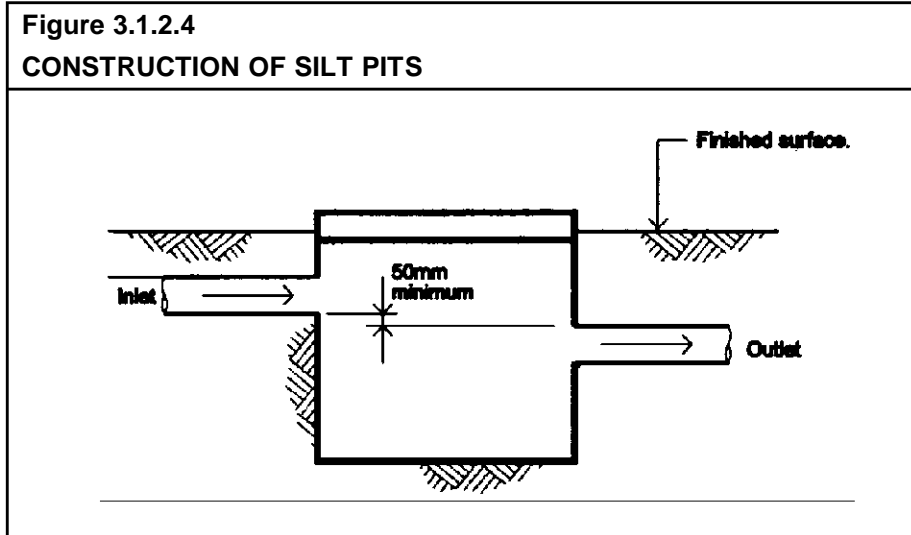

- (g) Drainage trenches in clay soils using sand filters must be constructed in accordance with Figure 3.1.2.5.

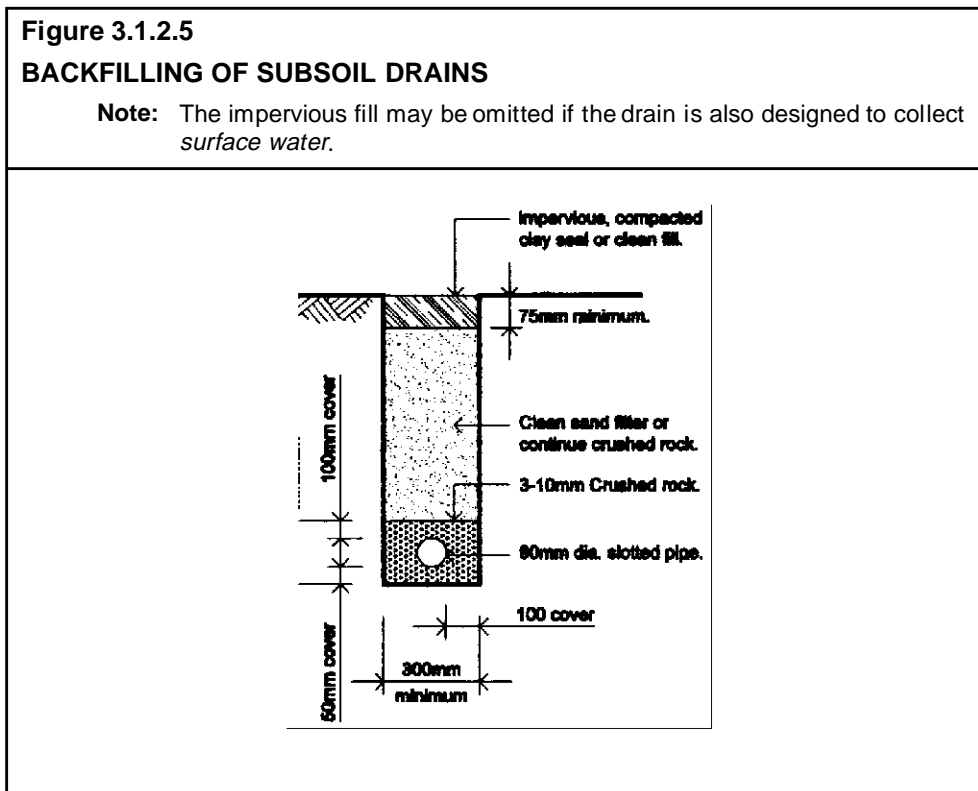

Amdt 3

Explanatory Information:

The design of alternative subsoil drains will need to consider the nature of the soil and the anticipated water level and movement. One of the main concerns with subsoil drains is to keep fine soil particles from clogging the soil filters and accordingly preventing free water movement.

The following are various configurations for subsoil drains using geotextile filters and different pipe configurations. Drainage may be achieved by trenches filled with filter material or enhanced using pipes such as slotted UPVC or geotextile wrapped PVC.

Subsoil drains may also be required on the uphill side of cut and fill *sites*; adjacent to deep strip footings, behind retaining walls, adjacent to basement walls etc in soil with poor drainage qualities or excessive sub-soil water movement.

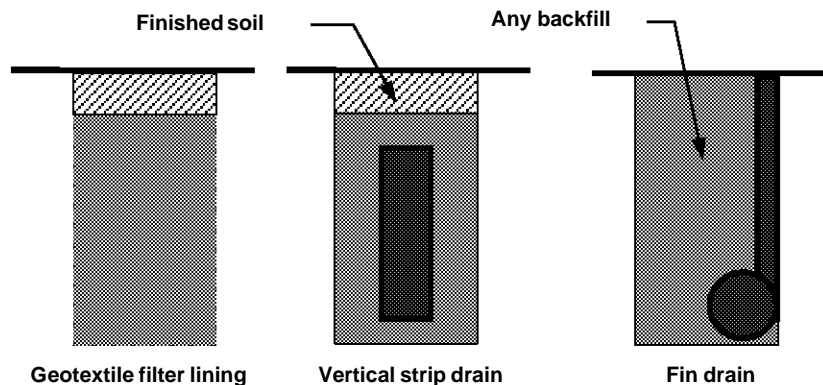

TYPICAL SUBSOIL DRAINS

3.1.2.5 Stormwater drainage

Where a stormwater drainage system is installed, it must comply with the following:

- (a) The position and manner of discharge of the stormwater drainage system must be to the satisfaction of the *appropriate authority*.
- (b) The stormwater drainage system must be designed so that any overflow during heavy rain periods is prevented from flowing back into the building.

Explanatory information:

The manner of discharge of stormwater drainage includes consideration of discharge points. Some examples of discharge points which may be acceptable to the *appropriate authority* are:

- (a) A legal discharge point at the allotment boundary.
- (b) On-site catchment systems, such as stormwater tanks.
- (c) On-site soil drainage systems, such as soaker wells.

Explanatory Information:

Stormwater drainage systems specified in the *Housing Provisions* are not designed to remove all of the water during exceptionally heavy rain, especially in tropical areas. Accordingly, it is necessary to design and install the system so that when overflowing occurs any water is directed away from the inside of the building and away from the building *foundation*.

To ensure that roof gutters do not overflow into the building consideration should be given to using slotted gutters, locating the gutter so that it is below the top edge of the fascia, the installation of rainwater heads with overflow slots etc.

Special attention needs to be given to box gutters, valley gutters etc located above the internal areas of a building. In these situations if adequate overflow controls cannot be implemented there may be a need to increase the size and capacity of drainage components to remove all water anticipated during heavy rain periods.

(c) Cover to stormwater drains

The cover to 90 mm UPVC stormwater drains installed underground must be not less than-

3.1.2.5(c)
Amdt No. 2

- (i) under soil - 100 mm; or
- (ii) under paved or concrete areas - 50 mm; or
- (iii) under areas subject to light vehicle traffic-
 - (A) reinforced concrete - 75 mm; or
 - (B) paved - 100 mm.

Explanatory Information:

Different depths of soil cover (or no cover at all) can be achieved using other types of pipes. The cover specified is measured from the top of the pipe to either the finished ground level or, in the case of paved or concreted areas, to the underside of the paving or concrete.

PART 3.1.3 TERMITE RISK MANAGEMENT

Definitions

3.1 The following definitions are used in this Part:

3.1
Amdt No. 3

Primary building element means a member of a building designed specifically to take part of the building load and includes roof, ceiling, floor, stairway or ramp and wall framing members including any bracing members designed for the specific purpose of acting as a brace to those members.

Explanatory information:

The loads to which a building may be subjected are dead, live, wind, snow and earthquake loads. Further information on building loads can be found in AS 1170.1.

3.1.3 Application

- (a) The requirements of this Part apply when a *primary building element* of a Class 1 and 10 building is considered susceptible to termite attack.
- (b) This Part does not apply to Class 1 and 10 buildings as follows (see also Figure 3.1.3.1):
 - (i) Buildings in areas where subterranean termites are not known to present a potential risk of attack to the *primary building elements* of the building.

Explanatory Information:

Termites are not considered to be a risk in Tasmania and a lesser risk in parts of Victoria and the Australian Capital Territory. The *appropriate authority* may have records of termite activity for each area and may be able to advise you on whether protection is needed.

- (ii) Buildings that have all their *primary building elements* constructed of one, or a combination of, the following materials:
 - (A) Steel.
 - (B) Concrete.
 - (C) Masonry.
 - (D) Fibre-reinforced cement.
 - (E) Naturally termite resistant timber in accordance with Appendix A of AS 3660.1.
 - (F) Preservative treated timber in accordance with Appendix B of AS 3660.1.

(iii) Buildings in Tasmania.

NT var.
Amdt No. 2

STATE AND TERRITORY VARIATIONS

3.1.3(b)(ii)(E) is replaced by the following clause in the Northern Territory.

(E) Naturally termite resistant timber in accordance with Appendix A of AS 3660.1 in areas where *Mastotermes darwiniensis* are not prevalent.

Amdt 3

Figure 3.1.3.1

FLOW CHART FOR IDENTIFYING IF A TERMITE BARRIER IS REQUIRED

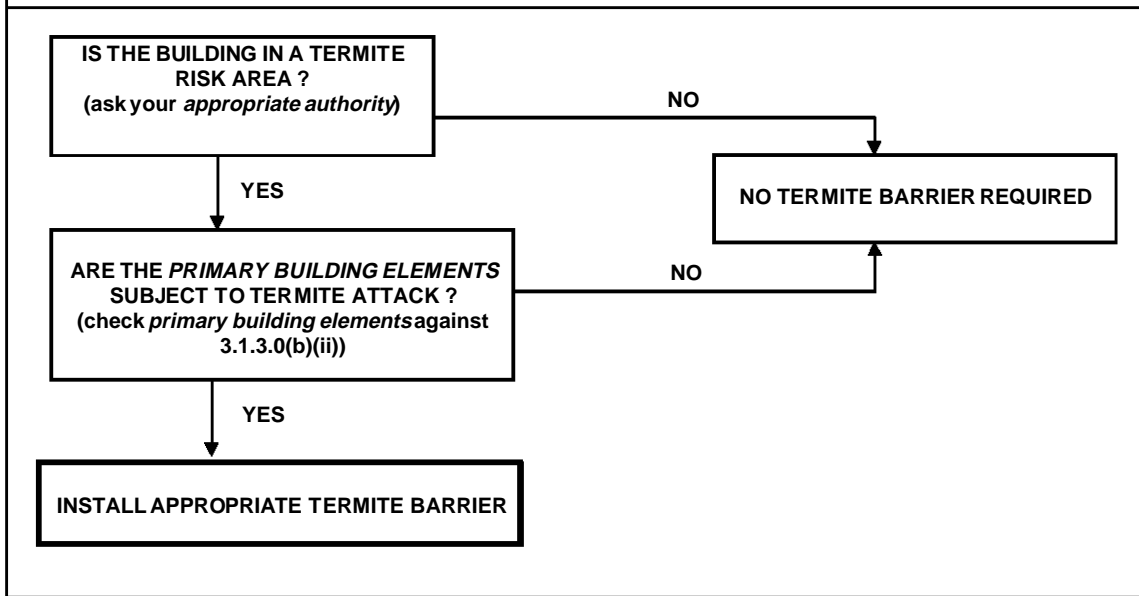

Appropriate Performance Requirements:

Where an alternative termite barrier or system is proposed to that described in Part 3.1.3, that proposal must comply with *Performance Requirement P2.1* in Section 2.

A. Acceptable construction manual

3.1.3.0 Acceptable construction manual

Performance Requirement P2.1 is satisfied for termite risk management if:

- (a) a termite barrier is installed in a Class 1 or 10 building to protect the *primary building elements* in accordance with AS 3660.1 - Protection of buildings from subterranean termites - New buildings; and
- (b) a durable notice is installed in accordance with 3.1.3.2(b).

STATE AND TERRITORY VARIATIONSNT var.
Amdt No. 2**In the Northern Territory delete 3.1.3.0(b) and insert 3.1.3.0(b) and (c) as follows:**

- (b) a durable notice is installed in accordance with 3.1.3.2(b); and
- (c) additional termite risk management measures are used in areas where *Mastotermes darwiniensis* are prevalent.

B. Acceptable construction practice**3.1.3.1 Application**

Compliance with this Part satisfies *Performance Requirement P2.1* for termite risk management.

STATE AND TERRITORY VARIATIONSNT var.
Amdt No. 2**3.1.3.1 is replaced by the following clause in the Northern Territory.**

Compliance with this Part satisfies *Performance Requirement P2.1* for termite risk management provided that additional termite risk management measures are used in areas where *Mastotermes darwiniensis* are prevalent.

Explanatory Information:

The intent of these requirements is to provide for a termite barrier that will ensure that termites will not enter a building by a concealed route. The installation of termite barriers will not stop termite activity from occurring on the site.

3.1.3.2 Installation of termite barriers

- (a) A termite barrier or combination of barriers is installed in accordance with-
 - (i) AS 3660.1; or
 - (ii) 3.1.3.3 for concrete slabs on ground; or
 - (iii) 3.1.3.4 for suspended floors.

(For barrier options see Table 3.1.3.1).
- (b) A durable notice must be permanently fixed to the building in a prominent location, such as in a meter box or the like, indicating-
 - (i) the method of protection; and
 - (ii) the date of installation of the system; and

- (iii) where a chemical barrier is used, its life expectancy as listed on the National Registration Authority label; and
- (iv) the installer's or manufacturer's recommendations for the scope and frequency of future inspections for termite activity.

Explanatory Information:

Durable notice

A durable notice must be fixed to the building in a prominent location advising the building occupants that the system should be inspected and maintained.

The notice should be clearly written, on a material that will not deteriorate or fade over time and be located in or near the meter box or similar location so that it can be easily seen and read by future owners of the building. Additional information may be included if desired by the person placing the notice.

Amdt 3

Table 3.1.3.1					
ACCEPTABLE TERMITE BARRIERS					
PROTECTION METHOD (as per AS 3660.1)	FOOTING SYSTEM				Suspended floors
	Concrete slab on ground complying with AS 2870		Concrete slab on ground not complying with AS 2870		
	Penetrations and control joints	Slab perimeter	Beneath slab (includes penetrations and control joints)	Slab perimeter	
Slab edge exposure	Not suitable	Suitable	Not suitable	Suitable	Not applicable
Termite shielding	Not suitable	Not suitable	Not suitable	Not suitable	Suitable
Stainless steel mesh	Partial; or Full system	Partial; or Full system	Full system	Full system	Suitable
Graded stone	Partial; or Full system	Partial; or Full system	Full system	Full system	Partial; or Full system
Chemicals	Full system beneath slab	Perimeter system	Full system beneath slab	Perimeter system	Full system

Explanatory information:

In addition to the acceptable termite barriers described in Table 3.1.3.1, other methods or systems can be used if it can be demonstrated that they meet the relevant *performance requirements* of the *Housing Provisions*. Forms of evidence of suitability are described in Part 1.2 - Acceptance of design and construction.

3.1.3.3 Barriers for concrete slab-on-ground

- (a) Where a concrete slab-on-ground is to be used as part of a termite barrier system, the slab must be designed and constructed to comply with AS 2870, and-
- (i) monolithic slabs must have penetrations and the perimeter of the slab protected in accordance with Table 3.1.3.1 (see Figure 3.1.3.2); and
 - (ii) non-monolithic slabs must have penetrations, control joints and the perimeter of the slab protected in accordance with Table 3.1.3.1 (see Figure 3.1.3.3).
- (b) Slabs not constructed in accordance with AS 2870 must have the full area beneath the slab and the perimeter protected in accordance with Table 3.1.3.1.
- (c) The edge of a slab-on-ground may be used as a perimeter barrier provided-
- (i) the slab edge is left exposed, not less than 75 mm above finished ground level; and
 - (ii) the face of the exposed edge is not rough or honeycombed and does not contain ripples caused by folds in the vapour barrier or the like that could conceal termite activity.

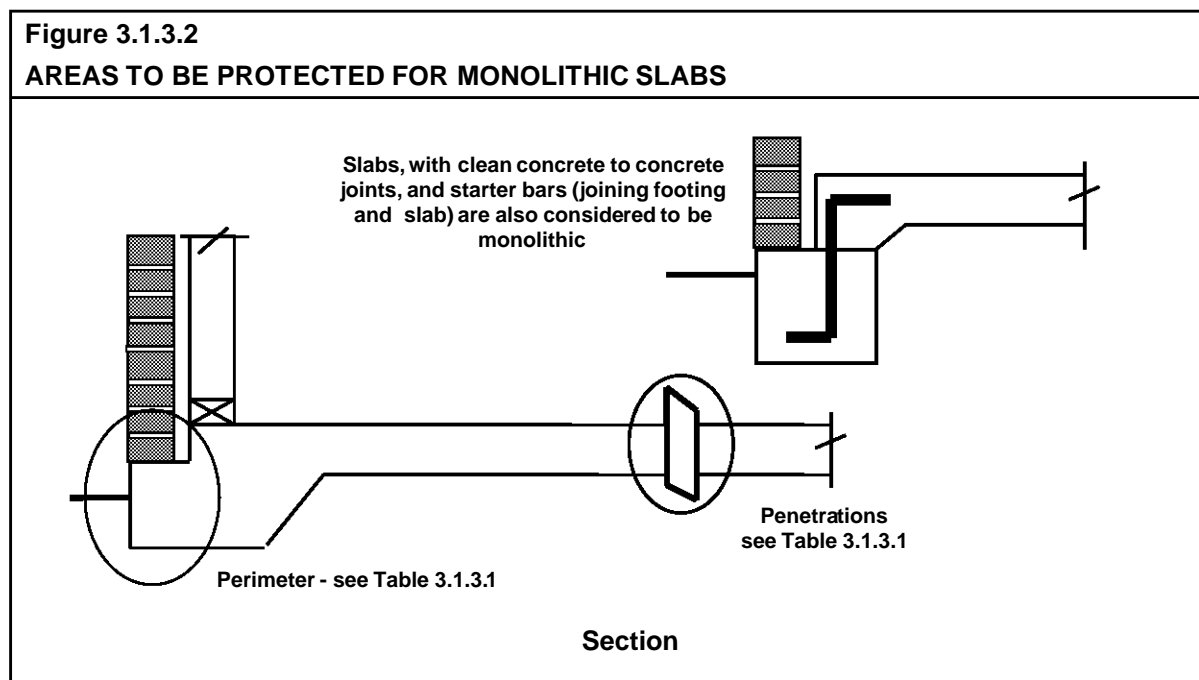

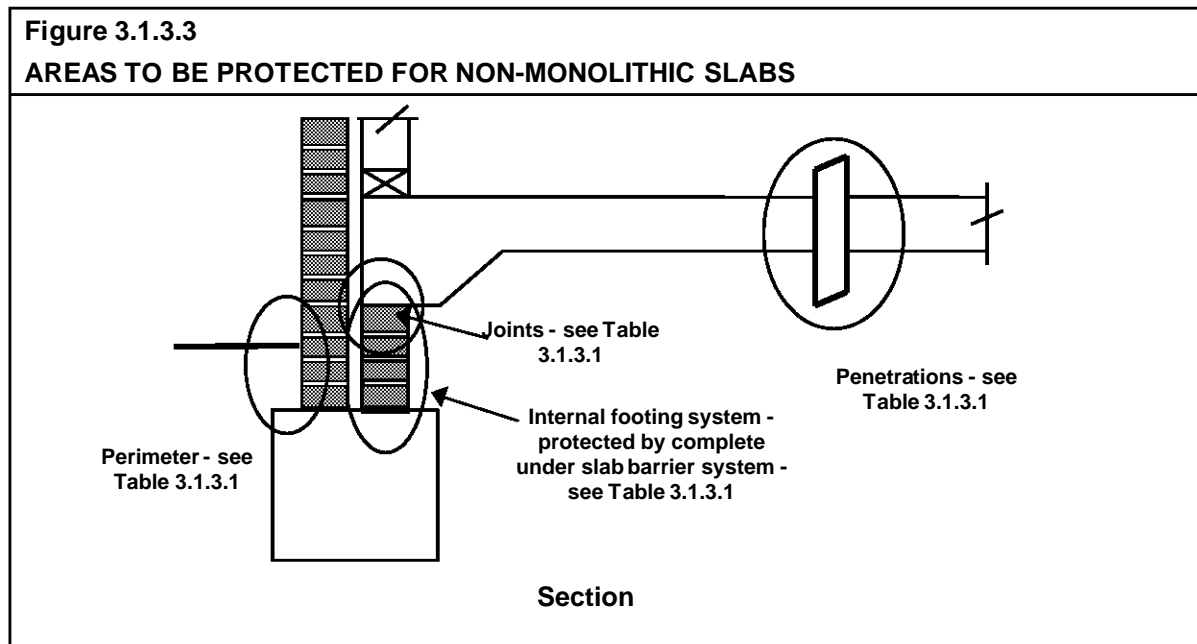

3.1.3.4 Protection of suspended floors

The area beneath a suspended floor of a building must be protected as follows-

- (a) install a barrier system in accordance with Table 3.1.3.1; and
- (b) provide sub-floor ventilation at a rate of not less than 7300 mm² per lineal metre in accordance with Part 3.4.1; and
- (c) where a barrier that needs to be inspected is installed, provide access to the area of the barrier that needs inspection in accordance with AS 3660.1.

Explanatory information: Termites

1. Barriers - Part of a system

There are more than 350 species of termites in Australia, about 30 of which achieve economic importance by causing costly damage to building structures. Due to the nature of termites, it is extremely difficult to prevent them gaining access to a building.

In addition to the correct installation of a termite barrier, its effectiveness will rely on regular maintenance and competent inspection.

The requirements in the BCA are minimum requirements and owners of buildings may choose to incorporate additional termite protection systems in their buildings.

2. The slab as a barrier

A concrete slab, designed and constructed in accordance with AS 2870, can form part of an acceptable termite barrier system. Cracking of the slab is common and does not necessarily indicate the failure of the termite barrier. Most cracks, including those that may appear quite wide on the surface do not necessarily extend for the full depth of the slab.

Explanatory information: (continued)**3. Slab edge exposure**

This approach is similar to that applied to termite shields in that termite activity is forced onto the exposed edge of the slab where with regular inspections termite ingress via the perimeter of the building can be detected.

The exposed edge of the slab should be kept clean. Debris such as leaves should be removed to ensure the full 75 mm of the slab is always visible. Attachments to the buildings such as downpipes should be located in such a manner to permit visual inspection. A clearance of not less than 40 mm is adequate between such fittings and the slab.

The fixing of tiles or rendering of the exposed surface is not permitted.

4. Protection of sub-floor areas

The area beneath a building requires special attention to ensure the effectiveness of the termite barrier. The following points should be observed.

(a) Subfloor ventilation - In suspended floor areas it is important that termite activity is not encouraged by inadequate subfloor ventilation. In conjunction with physical or chemical barriers air flow is critical. Air flow will not only restrict the growth of fungus which attacks subfloor members (which makes them more susceptible to termite attack), but also creates a climatic atmosphere less conducive to termite activity.

(b) Subfloor access - Termite shielding installed below suspended floors relies on access for both inspection and maintenance to be effective. Accordingly, minimum clearance heights will need to be achieved between the building structure (including ducts) and the ground to allow easy access to all areas where termite shields are used.

Perimeter access doors will also be needed where access is required for inspection and maintenance.

PART **3.2**

Amdt 3

FOOTINGS AND SLABS

3.2 Footings and slabs

3.2.2 Preparation

3.2.3 Concrete and Reinforcing

3.2.4 Site Classification

3.2.5 Footing and Slab Construction

PART 3.2 CONTENTS

	Page
3.2 Footings and slabs	7,021
3.2 Definitions	
3.2.0 Acceptable construction manuals	
3.2.1 Application	
3.2.2 Preparation	7,201
3.2.2.1 Excavation for footings	
3.2.2.2 Filling under concrete slabs	
3.2.2.3 Foundations for footings and slabs	
3.2.2.4 Slab edge support on sloping sites	
3.2.2.5 Stepped footings	
3.2.2.6 Vapour barriers	
3.2.2.7 Edge rebates	
3.2.3 Concrete and reinforcing	7,401
3.2.3.1 Concrete	
3.2.3.2 Steel reinforcement	
3.2.4 Site classification	7,601
3.2.4.1 Site classification	
3.2.5 Footing and slab construction	7,801
3.2.5.1 Footing and slab construction	
3.2.5.2 Footings and slabs to extensions to existing buildings	
3.2.5.3 Shrinkage control	
3.2.5.4 Minimum edge beam dimensions	
3.2.5.5 Footings for fireplaces on Class A and S sites	
3.2.5.6 Stump footing details	

Explanatory information:

This Part specifies the requirements for the excavation and filling for the footing or slab together with the construction of various alternative concrete slab and footing configurations.

The slab and footing configurations detailed in Part 3.2.5 are only suitable for the specified soil classifications. The requirements contained in the remainder of this Part are more general and may be applied to all slab and footing construction.

PART 3.2 FOOTINGS AND SLABS

Appropriate Performance Requirements:

Where an alternative footing system is proposed to that described in Part 3.2, that proposal must comply with-

- (a) Performance Requirement P2.1; and
- (b) Performance Requirement P2.2.3, in Section 2.

Definitions

3.2 The following definitions are used in this Part:

Articulated masonry means masonry construction in which special provisions have been made for movement by articulation (see 3.3.1.8).

Clad frame means timber or metal frame construction with exterior timber or sheet wall cladding that is not sensitive to minor movement and includes substructure masonry walls up to 1.5 m high.

Controlled fill means material that has been placed and compacted in layers with compaction equipment (such as a vibrating plate) within a defined moisture range to a defined density requirement.

Finished ground level means the ground level adjacent to footing systems at the completion of construction and landscaping.

Footing means construction that transfers the load from the building to the *foundation*.

Loadbearing wall, for the purposes of this part, means any wall imposing on the footing a load greater than 10 kN/m.

Mixed construction means a building consisting of more than one form of construction, particularly in double-storey buildings.

Rolled fill means material placed in layers and compacted by repeated rolling by an excavator.

Single leaf masonry means outer walls constructed with a single thickness of masonry unit.

Waffle raft means a stiffened raft with closely spaced ribs constructed on the ground and with slab panels supported between ribs.

A. Acceptable construction manuals

3.2.0 Performance Requirements P2.1 and P2.2.3 are satisfied for footings and slabs if they are installed in accordance with one of the following manuals:

- (a) The footing or slab is constructed in accordance with AS 2870.
- (b) Piled footings are designed in accordance with AS 2159.

Explanatory information:

Composite construction - design requirements for other materials that may be used in combination with the above footing systems, including the use of heavy steel support beams etc. are described in Part 3.11 - structural design codes.

B. Acceptable construction practice**3.2.1 Application**

Compliance with this Part satisfies *Performance Requirements* P2.1 and P2.2.3 for footings and slabs, provided-

- (a) the footing is on a Class A, S or M *site* (classified in accordance with AS 2870) with a uniform bearing capacity; and
- (b) the slab is not more than 25 m long; and
- (c) slabs containing permanent joints (eg construction joints) are not used; and
- (d) the structure supported by the footing is not more than-
 - (i) two storeys where a suspended concrete floor is used at the first floor level; or
 - (ii) three storeys where-
 - (A) suspended concrete floors are not used above the ground floor level; and
 - (B) the wall height excluding any gable is not more than 8 m; and
- (e) the building does not include wing walls or masonry arches not detailed for movement in accordance with Cement and Concrete Association of Australia TN 61; and
- (f) single leaf earth or stone masonry walls do not exceed 3 m in height; and
- (g) the *site* is considered to be normal as defined in Part 3.1.1, and
- (h) the *site* is not located in an *alpine area*.

PART 3.2.2 PREPARATION

3.2.2.1 Excavation for footings

- (a) Excavation for footings, including thickenings for slabs and pads must be clean cut with vertical sides, wherever possible.
- (b) The base of the excavation must be-
 - (i) for flat *sites*, generally level but may slope not more than 1:40 to allow excavations to drain; and
 - (ii) sloping *sites* at an angle of not more than 1:10; and
 - (iii) stepped footings in accordance with 3.2.2.5.
- (c) Footing excavations must be free of loose earth, tree roots, mud or debris immediately before pouring concrete.
- (d) Topsoil containing grass roots must be removed from the area on which the footing will rest.
- (e) Excavation depths and soil cuts must comply with Part 3.1.1.

STATE AND TERRITORY VARIATIONS

3.2.2.1 (e) does not apply in New South Wales.

Note: In New South Wales the Local Government Act 1993 and the Local Government (Approvals) Regulation 1993 regulate matters relating to *siteworks* associated with the erection of a building including, the safeguarding of excavations and backfilling, provision of retaining walls to prevent soil movement, and support for neighbouring buildings.

- (f) On loose sand *sites* or *sites* subject to wind or water erosion, the depth below *finished ground level* for footings must be not less than 300 mm.
- (g) Height of finished slab-on-ground must be in accordance with 3.1.2.3(b).

3.2.2.2 Filling under concrete slabs

3.2.2.2
Amdt No. 2

Filling placed under a slab (except where the slab is suspended) must comply with the following:

- (a) Filling must be either *controlled fill* or *rolled fill* as follows:
 - (i) Sand used in *controlled fill* or *rolled fill* must not contain any gravel size material and achieve a blow count of 7 or more per 300 mm using the test method described in AS 1289, Method 6.3.3.
 - (ii) Clay used in *controlled fill* or *rolled fill* must be moist during compaction.

- (iii) *Controlled fill:*
 - (A) Sand fill up to 800 mm deep - well compacted in layers not more than 300 mm deep by vibrating plate or vibrating roller.
 - (B) Clay fill up to 400 mm deep - well compacted in layers of not more than 150 mm by a mechanical roller.
- (iv) *Rolled fill:*
 - (A) Sand fill up to 600 mm deep - compacted in layers of not more than 300 mm by repeated rolling by an excavator or other suitable mechanical equipment.
 - (B) Clay fill up to 300 mm deep - compacted in layers of not more than 150 mm by repeated rolling by an excavator or similar machine.
- (b) Fill with a depth greater than that specified in (a) must be installed in accordance with AS 3798.
- (c) A level layer of clean quarry sand must be placed on top of the fill, with a depth of not less than 20 mm.
- (d) A graded stone termite barrier complying with Part 3.1.3 may be substituted for the sand required in (c).

3.2.2.3 Foundations for footings and slabs

Footings and slabs, including internal and edge beams, must be founded on soil with an allowable bearing pressure as follows:

- (a) Slab panels, load support panels and internal beams - natural soil with an allowable bearing pressure of not less than 50 kPa or *controlled fill* or *rolled fill* compacted in accordance with 3.2.2.2.
- (b) Edge beams connected to the slab - natural soil with an allowable bearing pressure of not less than 50 kPa or *controlled fill* compacted in accordance with 3.2.2.2 (a) (iii) and extending past the perimeter of the building 1 m with a slope ratio not steeper than 2 horizontal to 1 vertical (see Figure 3.2.2.1).
- (c) Pad footings, strip footings and edge beams not connected to the slab, must be-
 - (i) founded in natural soil with an allowable bearing pressure of not less than 100 kPa; or
 - (ii) for Class A and S *sites* they may be founded on controlled sand fill in accordance with 3.2.2.2(a).

3.2.2.4 Slab edge support on sloping sites

Footings and slabs installed on the low side of sloping *sites* must be as follows:

- (a) Slab panels - in accordance with 3.2.2.3(a).

- (b) Edge beams-
 - (i) supported by *controlled fill* in accordance with 3.2.2.3(b) (see Figure 3.2.2.1, Option 1); or
 - (ii) supported by deepened edge beams or bulk piers designed in accordance with AS 3600 (see Figure 3.2.2.1, Option 2); or
 - (iii) deepened (as per AS 2870) to extend into the natural soil level with a bearing capacity in accordance with 3.2.2.3(b) (see Figure 3.2.2.1, Option 3); or
 - (iv) stepped in accordance with AS 2870.
- (c) Edge beams not connected to the slab, pad footings and strip footings - founded in accordance with 3.2.2.3(c).
- (d) Where an excavation (cut) of the natural ground is used it must be in accordance with Part 3.1.1.

Amdt 3

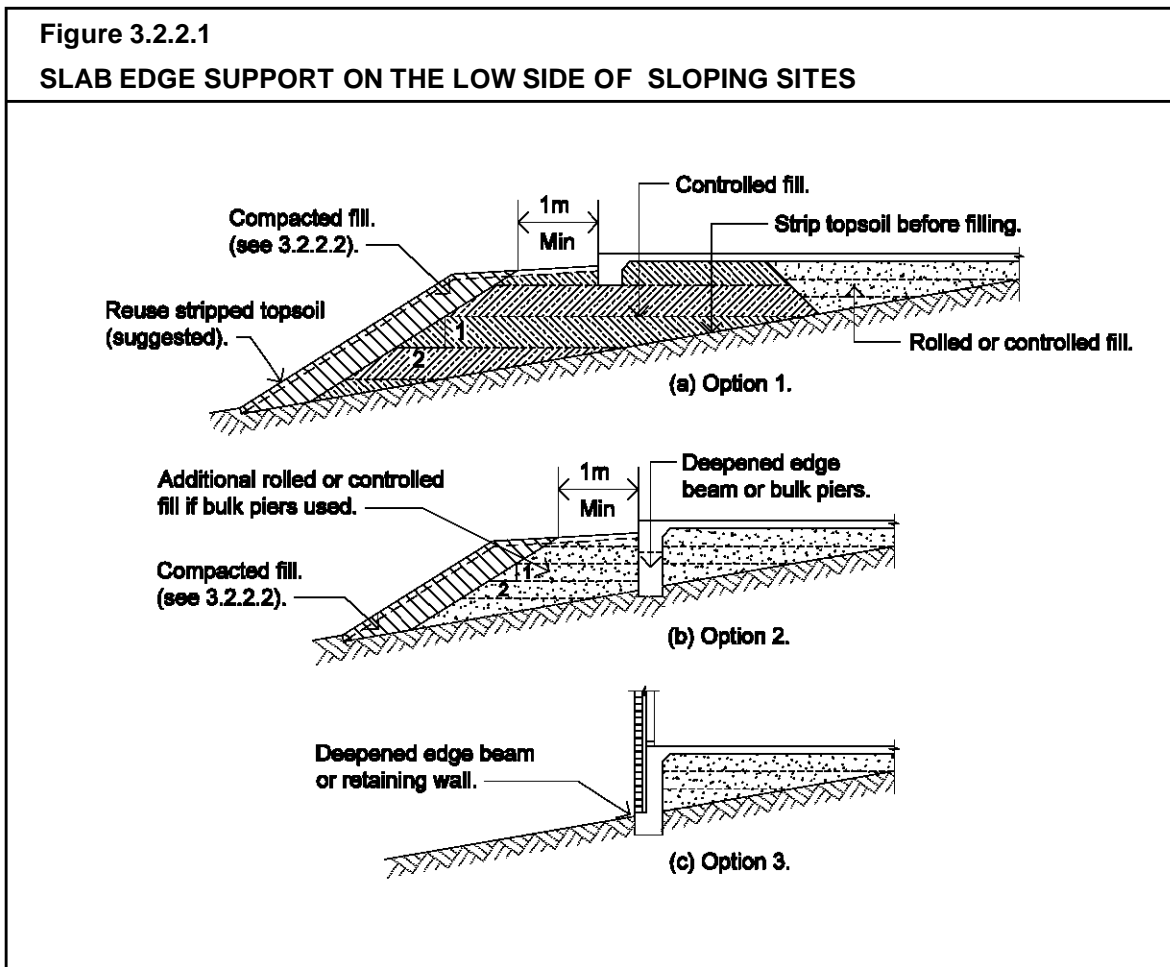

3.2.2.5 Stepped footings

Stepped strip footings must be constructed as follows-

- (a) the base of the footing must be horizontal or have a slope of not more than 1:10; or
- (b) be stepped in accordance with one of the methods shown in Figure 3.2.2.2.

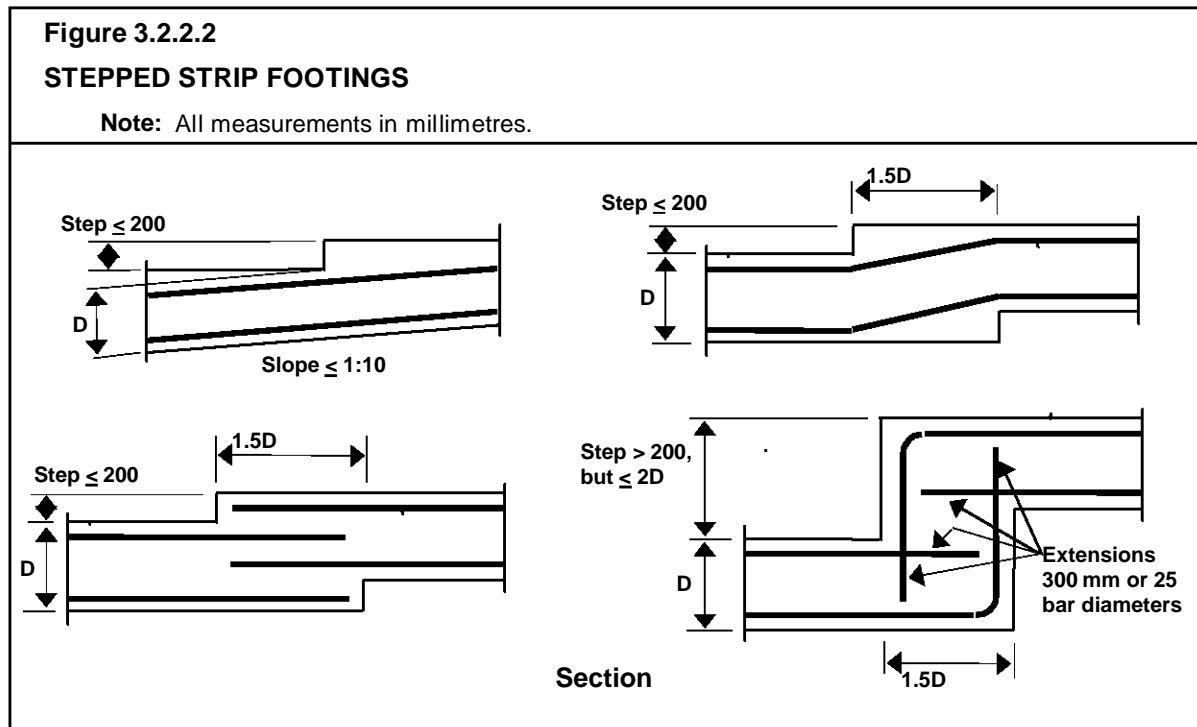
**3.2.2.6 Vapour barriers**

A vapour barrier must be installed under slab-on-ground construction for all Class 1 buildings and for Class 10 buildings where the slab is continuous with the slab of a Class 1 building as follows-

- (a) Materials

A vapour barrier must be-

- (i) 0.2 mm nominal thickness polyethylene film; and
- (ii) medium impact resistant,

determined in accordance with criteria specified in clause 5.3.3.2(c) of AS 2870; and

- (iii) be branded continuously "AS 2870 Concrete underlay, 0.2 mm Medium impact resistance".

(b) Installation

A vapour barrier must be installed as follows-

- (i) lap not less than 200 mm at all joints; and
 - (ii) tape or seal with a close fitting sleeve around all service penetrations; and
 - (iii) fully seal where punctured (unless for service penetrations) with additional polyethylene film and tape.
- (c) The vapour barrier must be placed beneath the slab so that the bottom surface of the slab is entirely underlaid and extend under edge beams to finish at ground level in accordance with Figure 3.2.2.3 (also see Figure 3.3.4.9 for single skin masonry details).

STATE AND TERRITORY VARIATIONS

In South Australia delete 3.2.2.6 and insert SA 3.2.2.6 as follows:

SA 3.2.2.6 Damp-proofing membrane

A continuous damp-proofing membrane must be installed under slab-on-ground construction for all Class 1 buildings as follows-

(a) Materials

A damp-proofing membrane must be-

- (i) 0.2 mm nominal thickness polyethylene film; and
- (ii) high impact resistant with resistance to puncturing and moisture penetration,

determined in accordance with criteria specified in clause 5.3.3.2(c) of AS 2870; and

- (iii) be branded continuously "AS 2870 Concrete underlay, 0.2 mm High impact resistance" together with the manufacturer's or distributor's name, trade mark or code.

(b) Installation

A damp-proofing membrane must be installed as follows-

- (i) lap not less than 200 mm at all joints; and
- (ii) tape or seal with a close fitting sleeve around all service penetrations; and
- (iii) fully seal where punctured (unless for service penetrations) with additional polyethylene film and tape.

- (c) The damp-proofing membrane must be placed beneath the slab so that the bottom surface of the slab is entirely underlaid and extend under edge beams to finish at ground level in accordance with Figure 3.2.2.3 (also see Figure 3.3.4.9 for single skin masonry details).

3.2.2.7 Edge rebates

Edge rebates for slab on ground, stiffened raft or *waffle raft* with masonry cavity or veneer construction must comply with the following:

- (a) The rebate must not be less than 20 mm, except as provided for in (d).
- (b) Exterior masonry must not overhang more than 15 mm past the edge of the slab.

- (c) The edge rebate must be flashed and drained in accordance with Part 3.3.4 and where it cannot be flashed it must be filled with mortar.
- (d) Edge rebates are not required for single-leaf masonry.

Explanatory Information:

See 3.2.5.4 for minimum edge beam details.

Figure 3.2.2.3

ACCEPTABLE VAPOUR BARRIER AND DAMP-PROOFING MEMBRANE LOCATION

Note: all dimensions in mm.

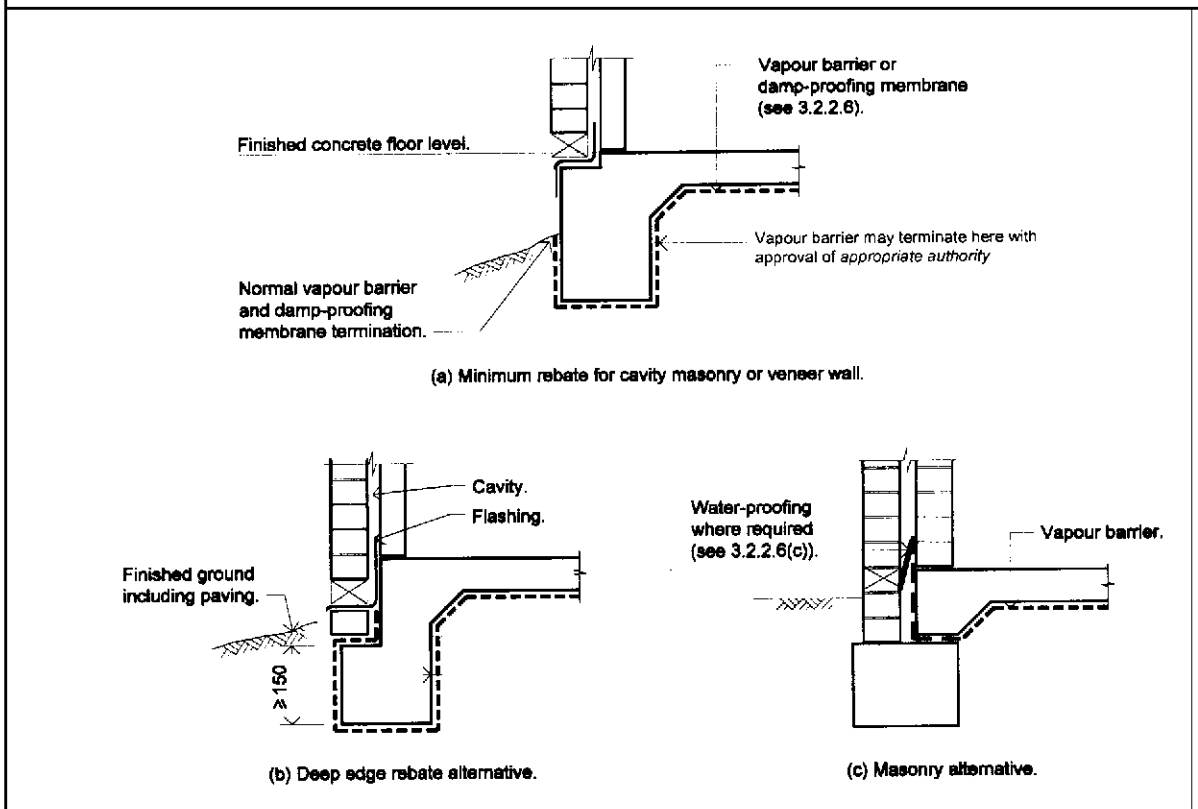

PART 3.2.3 CONCRETE AND REINFORCING

3.2.3.1 Concrete

Concrete must comply with the following:

- (a) Concrete must be manufactured to comply with AS 3600; and-
 - (i) have a strength at 28 days of not less than 20 MPa (denoted as N20 grade); and
 - (ii) have a 20 mm nominal aggregate size; and
 - (iii) have a nominal 80 mm slump.
- (b) Water must not be added to the mix to increase the slump to a value in excess of that specified.
- (c) Concrete must be placed and compacted in accordance with good building practice.
- (d) In hot (above 30°C) and windy conditions concrete must be cured by covering with plastic sheeting, spraying with a liquid membrane curing compound or ponding of water on the top surface.

STATE AND TERRITORY VARIATIONS

In South Australia after 3.2.3.1 (d) insert SA 3.2.3.1 (e), (f) and (g) as follows:

- (e) Concrete in slabs must be adequately compacted, and slab surfaces, including edges, moist cured for 7 days.
- (f) After vertical surfaces are stripped of formwork, slab edges must be finished prior to curing.
- (g) Loading of concrete slabs with stacked materials or building plant must not occur for a minimum of 7 days after pouring although construction of wall frames and setting out brickwork may be undertaken during this period.

Explanatory information:

Compacting concrete by vibration removes air pockets and works the concrete thoroughly around reinforcement, service penetrations etc and into corners of formwork to increase durability and resistance to termite infestation and salt damp attack. Care should be taken not to over-vibrate.

The finishing and curing of slab edges provides an improved edge finish which is resistant to edge dampness.

Explanatory information:

1. Complete discharge of the concrete from the truck should be made within one and a half hours of initial mixing with water unless a suitable retarder has been specified.
2. Care should be taken when using chemical curing methods, because some products may not be compatible with adhesives used to fix surface finishes to the slab.

3.2.3.2 Steel reinforcement

- (a) Materials used for reinforcing steel must comply with AS 2870 and be
 - (i) welded wire reinforcing fabric; or
 - (ii) trench mesh; or.
 - (iii) steel reinforcing bars.
- (b) Steel reinforcing bars may be substituted for trench mesh in accordance with Table 3.2.3.2.

Explanatory Information:

Reinforcement types referenced in this Part are described as follows:

1. Square fabric - F62, F72, F82, F92 or F102 (eg F62 consists of 6 mm diameter wires spaced at 200 mm centres.
2. Trench mesh - designated as the number and size of the longitudinal wires required, eg 3-8TM consists of 3 longitudinal 8 mm wires.
3. Steel reinforcing bars - are designated as x - Y12, x - Y16 etc where x is the number of bars required.

- (c) Minimum laps for reinforcement as shown in Table 3.2.3.1 and Figure 3.2.3.1 must be provided where reinforcing is used.

Table 3.2.3.1			
MINIMUM LAP FOR REINFORCEMENT			
Reinforcement	Minimum splice (mm)	Minimum Lap at "T" intersections	Minimum Lap at "L" intersections
Steel reinforcing bars	500	Full width across the junction	One outer bar must be bent and continue 500 mm (min) around corner
Trench mesh	500	Full width across the junction	Full width across the junction
Square and Rectangular Mesh	The two outermost transverse wires of one sheet must overlap the two outermost transverse wires of the other.	Not applicable	Not applicable

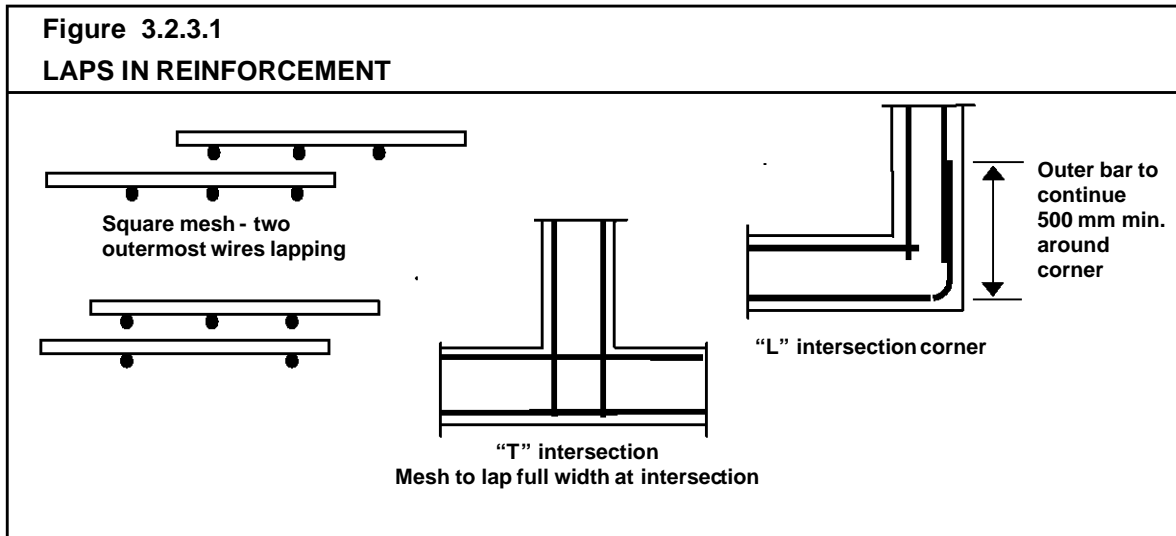

Amdt 3

**Table 3.2.3.2
ALTERNATIVE MESH/REINFORCING BAR SIZES**

Note: Where necessary 2 layers of mesh may be used.

Trench mesh (TM)	Area - mm ²	Reinforcing bar alternative	Trench mesh alternative
2-8TM	101	2-Y12	not applicable
3-8TM	151	2-Y12	not applicable
4-8TM	201	2-Y12	2-11TM
5-8TM	252	3-Y12	3-11TM
2-11TM	197	2-Y12	4-8TM
3-11TM	295	3-Y12	6-8TM
4-11TM	394	4-Y12	8-8TM
2-12TM	245	2-Y16	3-11TM
3-12TM	368	2-Y16	4-11TM
4-12TM	491	3-Y16	5-11TM

- (d) Footings and slabs on ground must have concrete cover between the outermost edge of the reinforcement (including ligatures, tie wire etc) and the surface of the concrete of not less than:
- (i) 40 mm to unprotected ground.
 - (ii) 30 mm to a membrane in contact with the ground.
 - (iii) 20 mm to an internal surface.
 - (iv) 40 mm to external exposure.
- (e) Reinforcement must be cleaned of loose rust, mud, paints and oils immediately prior to the concrete pour.

Explanatory information:

In order to obtain a good bond between concrete and reinforcement, the reinforcement should be free of contamination by mud, paint, oils, etc. It is not necessary for the reinforcement to be completely free of rust. Some rusting is beneficial in promoting a good bond as it roughens the surface of the steel. Loose rust, however, must be removed from the reinforcement.

- (f) Reinforcement must be placed as follows:
- (i) All reinforcement must be firmly fixed in place to prevent it moving during concreting operations.
 - (ii) Reinforcement must be supported off the ground or the forms by bar chairs made from wire, concrete or plastic.
 - (iii) When using wire chairs the minimum concrete cover (see 3.2.3.2(d)) to the uncoated portion of the chair must be obtained.
 - (iv) Wire chairs on soft ground or plastic membrane must be placed on flat bases.
 - (v) Bar chairs must be spaced at not more than 800 mm centres for steel fabric.

3.2.3.2(f)(iii)
Amdt No. 2

Explanatory information:

Reinforcement is designed to be in a particular place so as to add strength or to control cracking of the concrete. A displacement from its intended location could make a significant difference to the life or serviceability of the structure.

Supports for fabric reinforcement are provided to prevent the fabric distorting when workers walk on top of it to place the concrete and maintain the correct concrete cover to the fabric.

PART 3.2.4 SITE CLASSIFICATION

3.2.4.1 Site classification

The *foundation* where the footing is to be located must be classified in accordance with AS 2870.

Explanatory information:

Table 3.2.4.1 provides a general description of *foundation* soil types that will assist in the classification of the *site*. More detailed information, including differentiation between classifications, can be found in AS 2870 or alternatively contact the *appropriate authority*.

Due to the limitations of this Part, if a *site* is classified as H, E or P then reference must be made to AS 2870 for design and construction information.

Amdt 3

Explanatory information:

Table 3.2.4.1

GENERAL DEFINITION OF SITE CLASSES

Class	Foundation
A	Most sand and rock <i>sites</i> with little or no ground movement from moisture changes
S	Slightly reactive clay <i>sites</i> with only slight ground movement from moisture changes
M	Moderately reactive clay or silt <i>sites</i> which can experience moderate ground movement from moisture changes
H	Highly reactive clay <i>sites</i> which can experience high ground movement from moisture changes
E	Extremely reactive clay <i>sites</i> which can experience extreme ground movement from moisture changes
A to P	Filled <i>sites</i> (see AS 2870 and Part 3.2.2)
P	<i>Sites</i> which include soft soils, such as soft clay or silt or loose sands; landslip; mine subsidence; collapsing soils; soils subject to erosion; reactive <i>sites</i> subject to abnormal moisture conditions or <i>sites</i> which cannot be classified otherwise

PART 3.2.5 FOOTING AND SLAB CONSTRUCTION

Explanatory information:

The footings included in this Part reflect the requirements of AS 2870 and apply to the most common types of soil conditions. If the soil conditions on *site* are not covered by this Part then additional guidance can be obtained from AS 2870 or the *appropriate authority*.

These provisions are not meant to prohibit the use of alternative traditional footing methods found through experience to be suitable for local soil conditions (especially those used in stable soils). Such footings may be appropriate, provided they meet the relevant *Performance Requirements* listed in Section 2.

The diagrams in this Part reflect acceptable footing designs only. They do not provide details for termite barriers such as the correct placement of ant capping and slab edge exposure.

For details on termite barriers see Part 3.1.3.

3.2.5.1 Footing and slab construction

- (a) Footing and slab construction, including size and placement of reinforcement, must comply with the relevant provisions of this Part and the following details:
 - (i) Footings for stumps - the appropriate details in 3.2.5.6 and Table 3.2.5.2.
 - (ii) Stiffened raft Class A, S and M *sites* - the appropriate details in Figure 3.2.5.3.
 - (iii) Strip footing systems in Class A, S and M *sites* - the appropriate details in Figure 3.2.5.4.
 - (iv) Footing slabs for Class A *sites* - the appropriate details in Figure 3.2.5.5.
- (b) Footings for *single leaf masonry*, *mixed construction* and *earth wall masonry* must comply with the equivalent footing construction set out in Table 3.2.5.1.

3.2.5.2 Footings and slabs to extensions to existing buildings

- (a) Footings for extensions to Class 1 or 10 buildings may be of similar proportions and details to those used with an existing same Class of building on the same allotment provided-
 - (i) masonry and masonry veneer walls are articulated at the junction with the existing building; and
 - (ii) the performance of the existing building has been satisfactory (ie there has been no significant cracking or movement (see Section 2 of AS 2870 for acceptable footing performance); and
 - (iii) there are no unusual moisture conditions on the *site*.

- (b) Class 10 buildings of *clad framed* construction may use footing systems appropriate for one class of reactivity less severe than for a house.
 eg Site classification M can be reduced to S.

Table 3.2.5.1		
EQUIVALENT FOOTING CONSTRUCTION		
Actual construction		Equivalent footing construction (see Figures 3.2.5.2 to 5)
External walls	Internal walls	
Single leaf masonry		
Reinforced <i>single leaf masonry</i>	<i>Articulated masonry</i> on Class A and S sites; or framed	<i>Articulated masonry veneer</i>
Reinforced <i>single leaf masonry</i>	<i>Articulated masonry</i> or reinforced <i>single leaf masonry</i>	Masonry veneer
<i>Articulated single leaf masonry</i>	<i>Articulated masonry</i>	Articulated full masonry
Mixed construction		
Full masonry	Framed	Articulated full masonry
Articulated full masonry	Framed	Masonry veneer
Earth wall masonry		
Infill panels of earth masonry	Framed earth masonry	<i>Articulated masonry veneer</i>
<i>Load bearing</i> earth masonry	<i>Load bearing</i> earth masonry	Articulated full masonry

Amdt 3

3.2.5.3 Shrinkage control

- (a) Where brittle floor coverings are to be used (such as ceramic tiles) one of the following additional measures must be taken to control the effect of shrinkage cracking-
- (i) the amount of shrinkage reinforcement (steel reinforcement fabric in the slab panel) must be increased to F92 or equivalent throughout the affected slab panels; or
 - (ii) the bedding system for brittle coverings must be selected on the basis of the expected slab movement and the characteristics of the floor covering (including the use of expansion joints etc); or
 - (iii) the placement of floor covering must be delayed for not less than 3 months.

- (b) At re-entrant or internal corners, two strips, 2 m in length, of 3-8TM or one strip of 3-11TM (or 2-Y12 bars) must be placed diagonally across the corner in accordance with Figure 3.2.5.1.

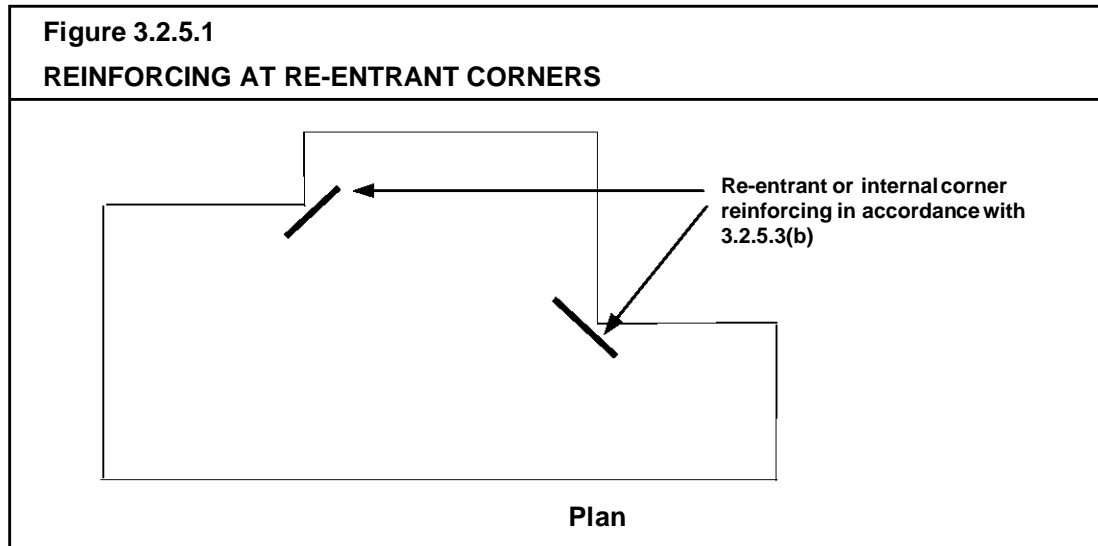

3.2.5.4 Minimum edge beam dimensions

Except for *waffle raft* slabs, where the edge rebate is more than 150 mm in depth, the width of the edge beam at the base of the rebate must not be less than 200 mm, except that if R10 ties at 900 mm spacing (or equivalent) are provided to resist vertical forces, the width of the edge beam can be reduced to 150 mm.

3.2.5.5 Footings for fireplaces on Class A and S sites

- (a) Fire places must be supported on a pad footing-
- (i) 150 mm thick for single storey (one trafficable floor and a wall height not more than 4.2 m) construction; and
 - (ii) 200 mm thick for 2 storey (two trafficable floors and a wall height not more than 8 m) construction; and
 - (iii) reinforced top and bottom with F72 mesh; and
 - (iv) extending 300 mm past the edges of the masonry except for any edge flush with the outer wall.
- (b) The pad footing may form an integral part of the slab.

3.2.5.6 Stump footing details

- (a) Footings for stumps must comply with-
- (i) the provisions of Table 3.2.5.2 for Class A and Class S sites; or

- (ii) the appropriate acceptable construction manual listed in-
 - (A) Part 3.4.3; or
 - (B) 3.2.0.
- (b) Concrete stumps must-
 - (i) be designed in accordance with-
 - (A) AS 3600; or
 - (B) Table 3.2.5.2; and
 - (ii) use a minimum 20 MPa concrete as defined in AS 3600;
- (c) Steel stumps must be-
 - (i) designed in accordance with-
 - (A) AS 1250; or
 - (B) Table 3.2.5.2; and
 - (ii) fully enclosed and sealed with a welded top plate; and
 - (iii) encased in concrete sloping away from the stump and finishing not less than 100 mm above *finished ground level*; and
 - (iv) corrosion protected in accordance with Part 3.4.4.
- 3.2.5.6
(d) to (f)
Amdt No. 3 (d) Timber stumps must be designed in accordance with-
 - (i) AS 1684; or
 - (ii) Table 3.2.5.2.
- (e) Stumps must be braced-
 - (i) by a full perimeter masonry base; or
 - (ii) for concrete stumps – in accordance with AS 3600; or
 - (iii) for steel stumps – in accordance with AS 1250; or
 - (iv) for timber stumps – in accordance with AS 1684.
- (f) Stumps must be embedded into the foundation material not less than 30% of their height above ground level or 450 mm, whichever is the greater.

Table
3.2.5.2
Amdt No. 3

Table 3.2.5.2 STUMP FOOTING - IN AREAS WITH A DESIGN WIND SPEED OF NOT MORE THAN W33				
LENGTH OF STUMP (mm) (including embedded length)	CONCRETE		STEEL	TIMBER
	Minimum size (mm)	REINFORCEMENT Number of 5 mm (min.) hard drawn wires	Minimum size (mm) (SHS = square hollow section)	Minimum size (mm)
Less than 1400	100 x 100 or 110 diameter	1	75 x 75 x 2.0 SHS	100 x 100 or 110 diameter
1401 - 1800	100 x 100 or 110 diameter	2	75 x 75 x 2.0 SHS	100 x 100 or 110 diameter
1801 - 3000	125 x 125 or 140 diameter	2	75 x 75 x 2.0 SHS	100 x 100 or 110 diameter

Amdt 3

Figure 3.2.5.2
Amdt No. 3

Figure 3.2.5.2
PAD FOOTINGS FOR CLAD FRAME, CLASS A AND S SITES

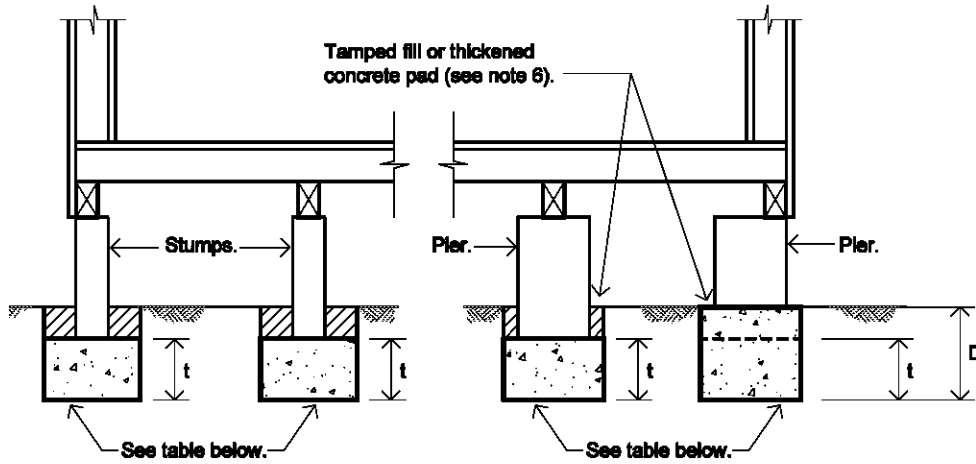

MINIMUM DIMENSIONS OF CIRCULAR AND SQUARE PAD FOOTINGS FOR CLAD FRAME CLASS A AND S SITES

Effective supported areas - m ²	Width of square pad - mm	Width of circular pad - mm	Thickness (t) - mm	Depth mm
10	400	500	200	400
20	500	600	200	400
30	600	750	250	400

Notes:

1. The effective area supported by a pad footing is the sum of-
 - (a) the supported floor area; and
 - (b) the supported roof area (if applicable); and
 - (c) half the supported wall area in elevation (if applicable).
2. The width or diameter can be reduced to one half the above footings on rock.
3. The pad footings must be constructed in concrete except that masonry footings can be used under masonry piers.
4. Pad footing sizes must also apply to footings supporting roof and floor loads only.
5. The *foundation* must provide an allowable bearing pressure of not less than 100kPa.
6. The excavation must be backfilled with manually rodded tamped soil, or the footing thickness shall be increased by 50 mm.
7. Where stump pad footings provide resistance to horizontal or uplift forces, the minimum size of the footing must comply with AS 2870.
8. Braced stumps must comply with 3.2.5.6(e).

Amdt 3

Figure 3.2.5.3

FOOTING SLAB AND STIFFENED RAFT SLAB DETAILS FOR CLASS A, S AND M SITES

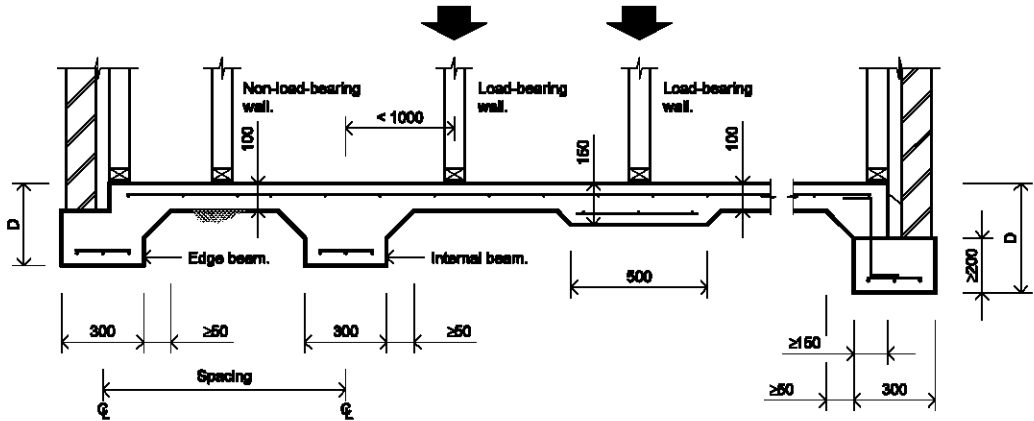

REINFORCEMENT FOR STIFFENED RAFT FOR CLASS A, S AND M SITES

Site Class	Type of Construction	Edge and internal Beams (see Note 1)			
		Depth (D) mm	Bottom Reinforcement	Spacing Centre to Centre (M)	Slab Fabric (see Note 2)
Class A	Clad frame	300	3- 8TM	-	F72
	Articulated masonry veneer	300	3- 8TM	-	F72
	Masonry veneer	300	3- 8TM	-	F72
	Articulated full masonry	400	3- 8TM	-	F82
	Full masonry	400	3- 8TM	-	F82
Class S	Clad frame	300	3- 8TM	-	F72
	Articulated masonry veneer	300	3- 8TM	-	F82
	Masonry veneer	300	3- 11TM	-	F82
	Articulated full masonry	400	3- 11TM	-	F82
	Full masonry	450	3- 11TM	5.0	F82
Class M	Clad frame	300	3- 11TM	6.0	F72
	Articulated masonry veneer	400	3- 11TM	6.0	F72
	Masonry veneer	400	3- 11TM	5.0	F72
	Articulated full masonry	500	3- 12TM	4.0	F82
	Full masonry	800	3- Y16	4.0	F92

Notes:

- Internal and external edge beams must be arranged to form an integral structural grid (see Clauses 5.3.8 and 5.3.9 of AS 2870).
- Slab fabric-
 - for slabs greater than 18 m in length - F82; and
 - for Class A and S sites wherever F82 is specified the fabric can be reduced to F72.
- A 10% increase in spacings is permitted where the spacing in the other direction is 20% less than specified.
- Where external beams are wider than 300 mm an extra bottom bar or equivalent of the same bar size is required for each 100 mm additional width.
- Where a reinforced single leaf masonry wall is constructed directly above and structurally connected to a concrete edge beam, the beam may be reduced to 300 mm wide by 300 mm deep and reinforced with 3-8TM reinforcement.
- Alternative reinforcing sizes must comply with AS 2870.

FIGURE 3.2.5.4
STRIP FOOTING SYSTEMS

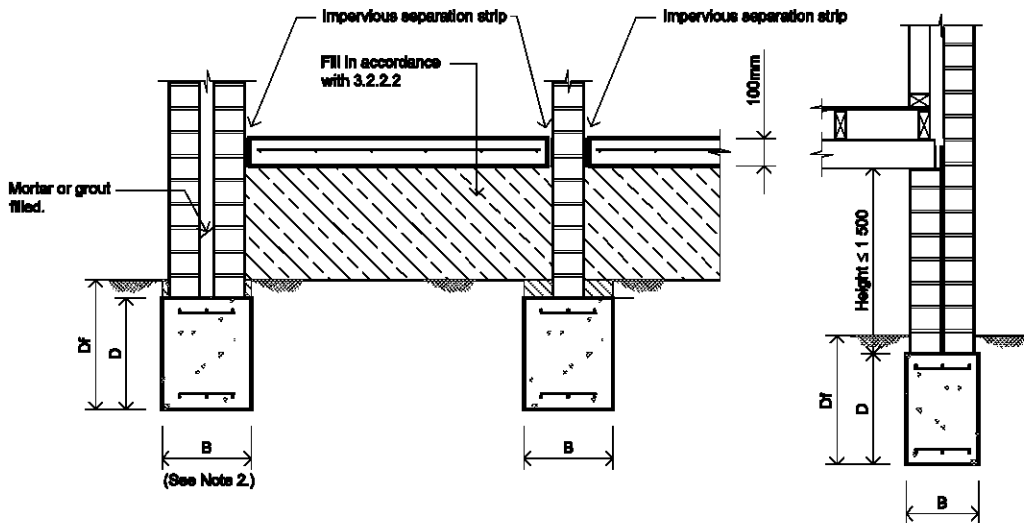

DIMENSIONS AND REINFORCEMENT FOR STRIP FOOTING SYSTEMS			
Site Class and type of construction	D (mm)	B (mm)	Reinforcement
Class A			
Clad frame	300	300	3- 8TM
Articulated masonry veneer	300	300	3- 8TM
Masonry veneer	300	300	3- 8TM
Articulated full masonry	300	400	4- 8TM
Full masonry	300	400	4- 8TM
Class S			
Clad frame	400	300	3- 8TM
Articulated masonry veneer	400	300	3- 8TM
Masonry veneer	400	300	3- 8TM
Articulated full masonry	400	400	4- 11TM
Full masonry	500	400	4- 11TM
Class M			
Clad frame	400	300	3- 11TM
Articulated masonry veneer	450	300	3- 11TM
Masonry veneer	500	300	3- 12TM
Articulated full masonry	600	400	4- 12TM
Full masonry	900	400	4- 12TM

Notes:

1. All masonry walls must be supported on strip footings.
2. For Class M articulated full masonry and full masonry internal strip footings must be of the same proportions at the external footing and run from external footing to external footing.
3. Infill floors may be concrete slabs, brick paving, stone flags or compacted and stabilised earth. Concrete infill slabs must use a minimum of F62 mesh to control shrinkage.
4. Where external beams are wider than 300 mm an extra bottom bar or equivalent of the same bar size is required for each 100 mm additional width.
5. The measurement D_f is greater than or equal to D plus 75 mm.
6. Alternative reinforcing sizes must comply with AS 2870.

Amdt 3

Figure 3.2.5.5

FOOTING SLABS FOR CLASS A SITES SUITABLE FOR:

- (a) CLAD FRAME.
- (b) ARTICULATED MASONRY VENEER.
- (c) MASONRY VENEER.
- (d) ARTICULATED FULL MASONRY.
- (e) FULL MASONRY.

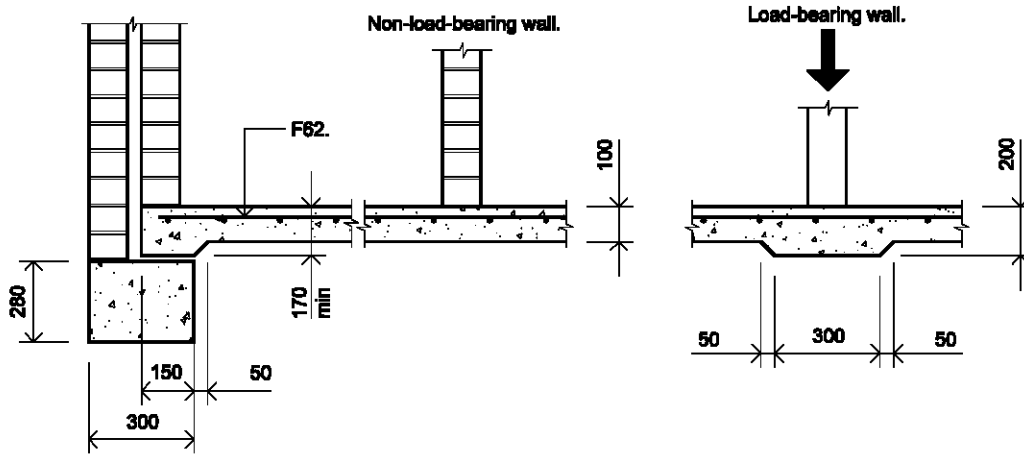

Notes:

1. Use F63 when slab length is less than or equal to 12 m.
2. Use F62 when slab length is less than or equal to 18 m.
3. Use F72 when slab length is more than 18 m.
4. In parts of Western Australia (around Perth) and other locations where the *site* consists of extremely stable sands, and where specified by a *professional engineer*, the slab thickness may be reduced to 85 mm and reinforced as follows:
 - (a) Use F53 when slab length is less than or equal to 12 m.
 - (b) Use F63 when slab length is less than or equal to 18 m.
 - (c) Use F62 when slab length is more than 18 m.
5. Dune sands may require compaction.

PART **3.3**

Amdt 3

MASONRY

3.3 Definitions

3.3.1 Unreinforced Masonry

3.3.2 Reinforced Masonry

3.3.3 Masonry Accessories

3.3.4 Weatherproofing of Masonry

3.3.5 Earthwall Construction

PART 3.3 CONTENTS

		Page
3.3	Definitions	9,012
3.3.1	Unreinforced masonry	9,021
3.3.1.0	Acceptable construction manual	
3.3.1.1	Application	
3.3.1.2	External walls	
3.3.1.3	Internal walls	
3.3.1.4	Isolated piers	
3.3.1.5	Masonry units	
3.3.1.6	Mortar mixes	
3.3.1.7	Mortar joints	
3.3.1.8	Vertical articulation joints	
3.3.1.9	Subfloor ventilation	
3.3.1.10	Shrinkage allowance for timber framing	
3.3.2	Reinforced masonry	9,301
3.3.2	Acceptable construction manual	
3.3.2.1	Application	
3.3.2.2	External wall construction	
3.3.3	Masonry accessories	9,601
3.3.3	Acceptable construction manual	
3.3.3.1	Application	
3.3.3.2	Wall ties	
3.3.3.3	Fixing straps and tie down systems	
3.3.3.4	Lintels	
3.3.4	Weatherproofing of masonry	9,801
3.3.4	Definitions	
3.3.4.0	Acceptable construction manual	
3.3.4.1	Application	
3.3.4.2	Width of cavity	
3.3.4.3	Cavity ventilation and drainage	
3.3.4.4	Damp proof courses - materials	
3.3.4.5	Damp proof courses - installation	
3.3.4.6	Flashings	
3.3.4.7	Weatherproofing for single skin masonry walls	
	Continued	

Amdt 3

Continued		
3.3.5	Earthwall construction	10,101
3.3.5	Definitions	
3.3.5.0	Acceptable construction manual	
3.3.5.1	Application	
3.3.5.2	General construction	
3.3.5.3	Minimum thickness of walls	
3.3.5.4	Weatherproofing	

Definitions

3.3 The following definitions are used in this Part:

Bond beam means a horizontal reinforced concrete or masonry member forming part of the masonry.

Cavity means a void between 2 leaves of masonry, or in masonry veneer construction, a void between a leaf of masonry and the supporting frame.

Engaged pier means a pier bonded monolithically to a masonry wall either by course bonding of masonry units or by ties.

Lateral support means a support (including footing, buttress, cross wall, beam, floor or braced roof structure) that effectively restrains the wall or pier at right angles to the face of the wall or pier.

Perpend means a vertical joint between adjacent masonry units.

Reinforced masonry means masonry reinforced with steel reinforcement that is placed in a bed joint or grouted into a core to strengthen the masonry.

Unreinforced masonry means masonry that is not reinforced.

PART 3.3.1 UNREINFORCED MASONRY

Appropriate *Performance Requirements*:

Where an alternative masonry walling system is proposed to that described in Part 3.3.1, that proposal must comply with *Performance Requirement P2.1* as specified in Section 2.

A. Acceptable construction manual

- 3.3.1.0** *Performance Requirement P2.1* is satisfied for *unreinforced masonry* (including masonry veneer) if it is designed and constructed in accordance with AS 3700 Masonry Code.

Explanatory information:

Composite construction: Design requirements for other materials that may be used in combination with masonry ie heavy steel support beams etc. are described in Part 3.11 - Structural design.

B. Acceptable construction practice

3.3.1.1 Application

Compliance with this Part satisfies *Performance Requirement P2.1* for *unreinforced masonry*, provided-

- (a) the *unreinforced masonry* is constructed on footings that comply with Part 3.2; and
- (b) the building is located in an area with a *design wind speed* of not more than W41; and
- (c) for earthquake design, the building is defined as a design category H1 or H2 domestic structure in accordance with AS 1170.4; and

Explanatory Information:

1. This covers all *sites* except those identified by the site investigation as having soft soil (having a soil profile with more than 5 m of soft clay, loose sand, silt or uncontrolled fill) as defined by AS 1170.4.
2. For earthquake design H3, see AS 3700.

- (d) the building is not constructed in an *alpine area*; and
- (e) masonry accessories, including wall ties and lintels are installed in accordance with Part 3.3.3.

3.3.1.2 External walls

- (a) Masonry veneer must comply with the relevant provisions of this Part and be constructed as follows:
 - (i) Bracing requirements - masonry veneer *external walls* must be tied to the *loadbearing* frame constructed in accordance with Part 3.4.
 - (ii) Masonry veneer walls, non-*loadbearing*, must be constructed with a leaf of masonry not less than 90 mm wide.
- (b) *Cavity* masonry and solid masonry walls must comply with the relevant provisions of this Part and be constructed as follows:
 - (i) The height of the wall between *lateral supports* (floor or roof) must be not more than 3 m with the exception of a gable where the height to the ridge may be not more than 5 m (refer to Figure 3.3.1.1).
 - (ii) Masonry cross walls must be-
 - (A) not less than 2 m in length at not more than 9 m centres; and
 - (B) connected directly or by a floor or ceiling diaphragm to the wall being supported.
- (c) *Cavity* walls must be constructed of two leaves, with each leaf not less than 90 mm wide.

Explanatory Information:

For minimum *cavity* widths for veneer and *cavity* masonry, see 3.3.4.2

Figure 3.3.1.1

HEIGHT RESTRICTIONS FOR MASONRY WALLS INCLUDING GABLE ROOF

Note: Flat ceilings may act as lateral support to walls.

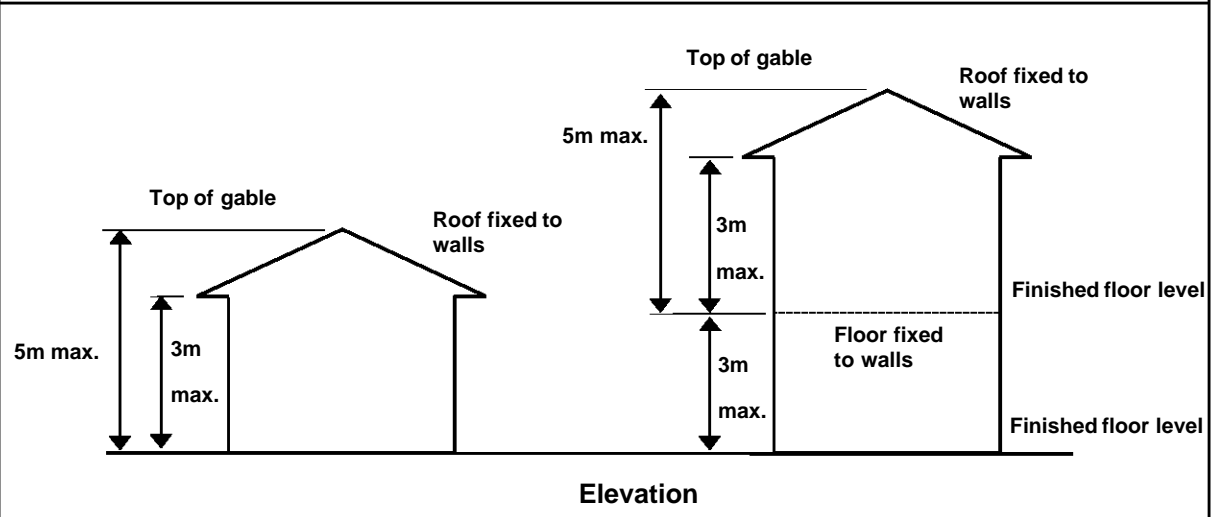

- (d) Unreinforced single leaf walls with *engaged piers* and return walls must comply with the relevant provisions of this Part and be constructed in accordance with the following:
- (i) The adjoining roof structure must be-
 - (A) connected to the *engaged piers*, (see Figure 3.3.1.2); or
 - (B) fixed to, or within 300 mm, of the return supports (see Figure 3.3.1.3).
 - (ii) Stack bonded piers must have wall ties at every 4th course.
 - (iii) Pier and return supports size limitations:
 - (A) Single-leaf *unreinforced masonry walls* with *engaged piers* must comply with Figure 3.3.1.2.
 - (B) Single-leaf *unreinforced masonry walls* with return supports must comply with Figure 3.3.1.3.
 - (iv) There must not be more than one opening per wall panel, and any opening must not be more than 900 mm high x 600 mm wide (see Figure 3.3.1.3).
 - (v) An *engaged pier* or return wall, must be provided at both sides of a door or full height window opening (see Figure 3.3.1.2).
 - (vi) Articulation joints must be located within 300 mm of vertical supports (see 3.3.1.8).

Fig 3.3.1.2
Amdt No. 3

Figure 3.3.1.2

PIERS IN EXTERNAL SINGLE LEAF WALLS (not more than W41)

Note: Piers are not required for 140 and 190 mm walls provided the roof structure is fixed to the walls at not more than 3.5 m centres to provide *lateral support* to the top of the walls.

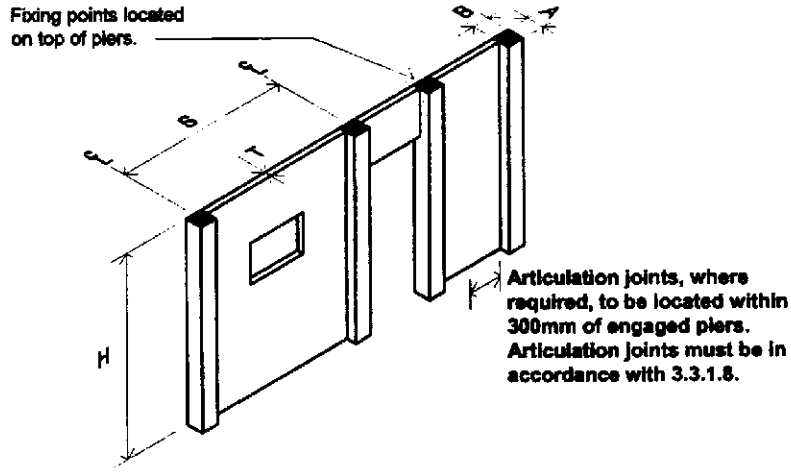

Thickness of wall (min.)		T	90	110	140	190
Pier size (min.)	Not more than W33	AxB	290x190	350x230	-	-
	Not more than W41	AxB	290X290 *	350x350 *	-	-
Spacing of piers (max.)		S	1650	1800	-	-
Height (max.)		H	2400	2700	2400	2700

* Piers in areas with a design wind speed of more than W33 must be vertically reinforced with at least 1/Y12, tied to the footing.

- (e) A Class 10a building containing not more than 1 storey may be enclosed with masonry *external walls* not less than 110 mm in thickness, provided that-
 - (i) the building measured in the direction of the span of the roof is not more than 9 m and the height is not more than 3 m; and

Amdt 3

- (ii) piers are formed that are not less than 230 mm wide, project not less than 120 mm and are spaced at not more than 3 m centres; and
- (iii) the roof does not place any thrust onto the *external walls*; and
- (iv) cross walls are constructed at not more than 9 m centres; and
- (v) the Class 10a building is located in an area with a *design wind speed* of not more than W33; and
- (vi) the building is a design category H1 domestic structure in accordance with AS 1170.4.

3.3.1.2(e)
(v) and (vi)
Amdt No. 3

Amdt 3

STATE AND TERRITORY VARIATIONS

3.3.1.2(e) does not apply in NSW.

Fig 3.3.1.3
Amdt No. 3

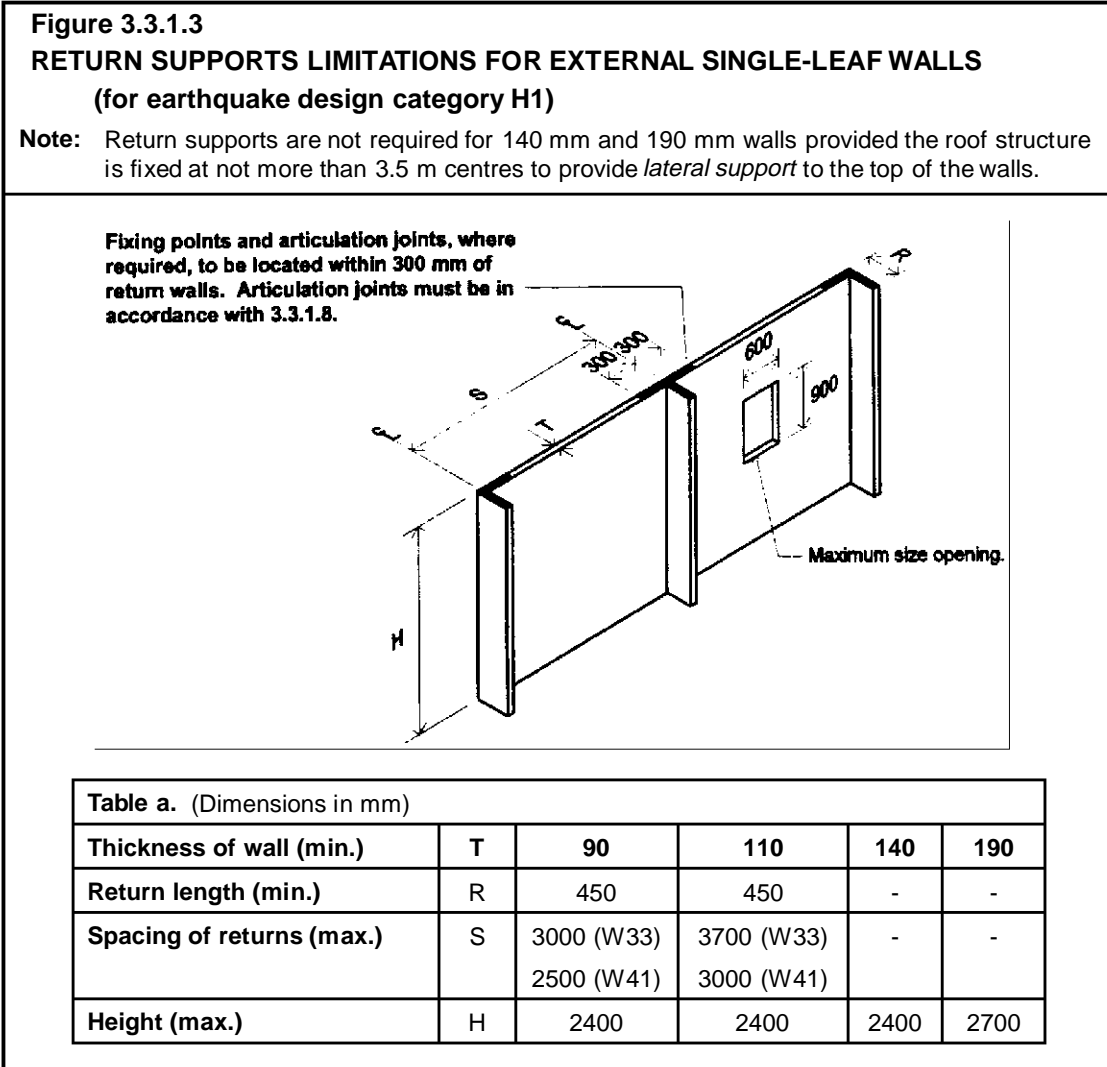

Amdt 3

3.3.1.3 Internal walls

Internal masonry walls must comply with the relevant provisions of this Part and be constructed as follows:

- (a) Internal masonry walls must be not less than 75 mm thick.
- (b) Where wall junctions occur they must be bonded or an articulation joint provided in accordance with 3.3.1.8.
- (c) Single leaf internal walls must be supported by either-
 - (i) the ceiling structure in accordance with Figure 3.3.1.4(a); or
 - (ii) return walls in accordance with Figure 3.3.1.4(b). A full height door frame or stud fastened at the ceiling framing and tied to the wall at 300 mm centres can be considered equivalent to a return wall.

Figure 3.3.1.4

SUPPORT FOR INTERNAL WALLS (Dimensions in mm)

Diagram a. Supported by ceiling structure

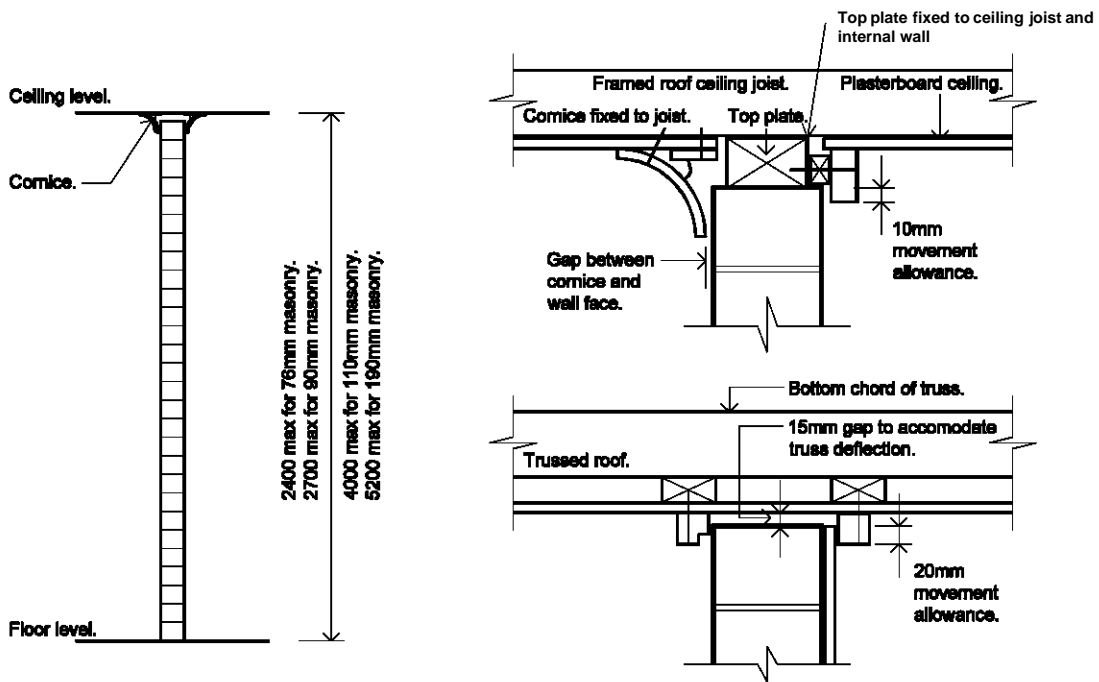
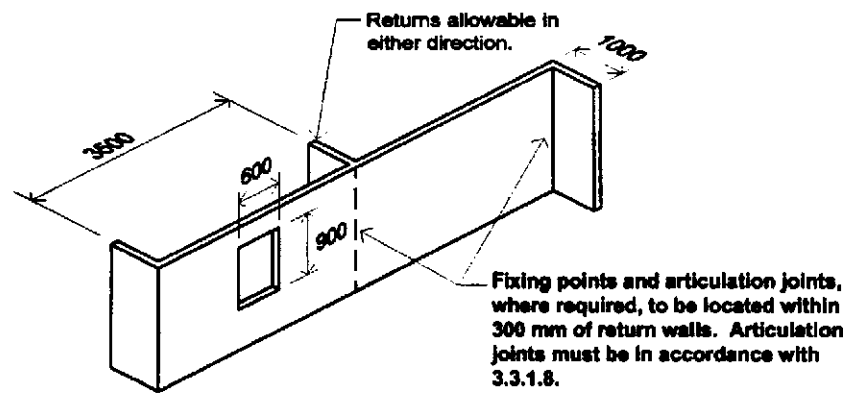

Fig 3.3.1.4b
Amdt No. 3

Diagram b. Supported by return walls

Note:

1. An opening of not more than 600x900 mm is allowed to internal walls; and
2. The maximum allowable height for the wall is described in Diagram a.



Amdt 3

3.3.1.4 Isolated piers

- (a) Isolated masonry piers supporting carports, verandahs, porches and similar roof structures, which form part of the main roof, or are attached to a wall of a Class 1 building must be not less than 290 x 290 mm and-
- (i) must be not more than 2.7 m high (see Figure 3.3.1.5); and
 - (ii) must be spaced at not more than 3 m centres (see Figure 3.3.1.5); and
 - (iii) must comply with the relevant parts of (b), (c) or (d); and
 - (iv) may also support a roller door.
- (b) Isolated piers supporting tiled roofs
- Isolated piers supporting tiled roofs must have a built-in 32 x 0.8 mm galvanised steel strap fixed to the roof structure and looped around a 10 mm diameter galvanised steel rod built into the pier not less than six courses below the top of the pier.
- (c) Isolated piers supporting sheet roofs must have-
- (i) a built-in 32 x 0.8 mm galvanised steel strap fixed to the roof structure and extending the full height of the pier which is looped around a 10 mm diameter galvanised steel rod cast into the footing when poured; or
 - (ii) a 10 mm diameter galvanised steel rod cast into the footing, threaded at the top and extending the full height of the pier.
- (d) Piers for a free standing carport must-
- (i) be not less than 290 x 290 mm with the central core filled with 20 MPa concrete, or an exposure class mortar (see Table 3.3.1.2) complying with 3.3.1.6; and
 - (ii) have the core reinforced with 1 Y12 steel reinforcing rod cast into the footing and extending the full height of the pier to connect to the roof structure.
- (e) Sub-floor isolated piers must comply with Figure 3.3.1.6.

Figure 3.3.1.5
ISOLATED PIERS UNDER MAIN ROOF

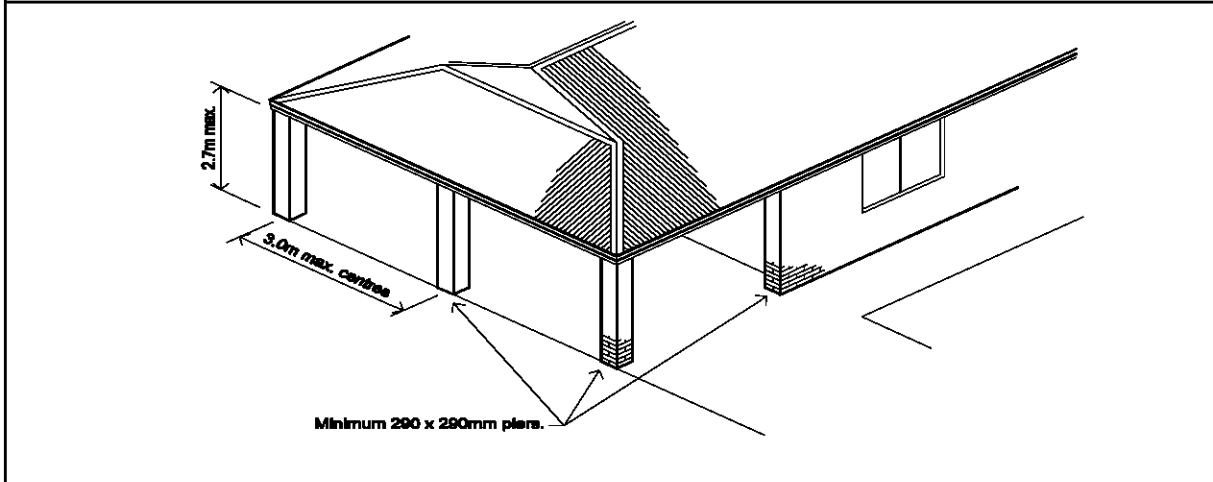

Amdt 3

Figure 3.3.1.6
SUB-FLOOR ISOLATED PIERS - MAXIMUM HEIGHTS

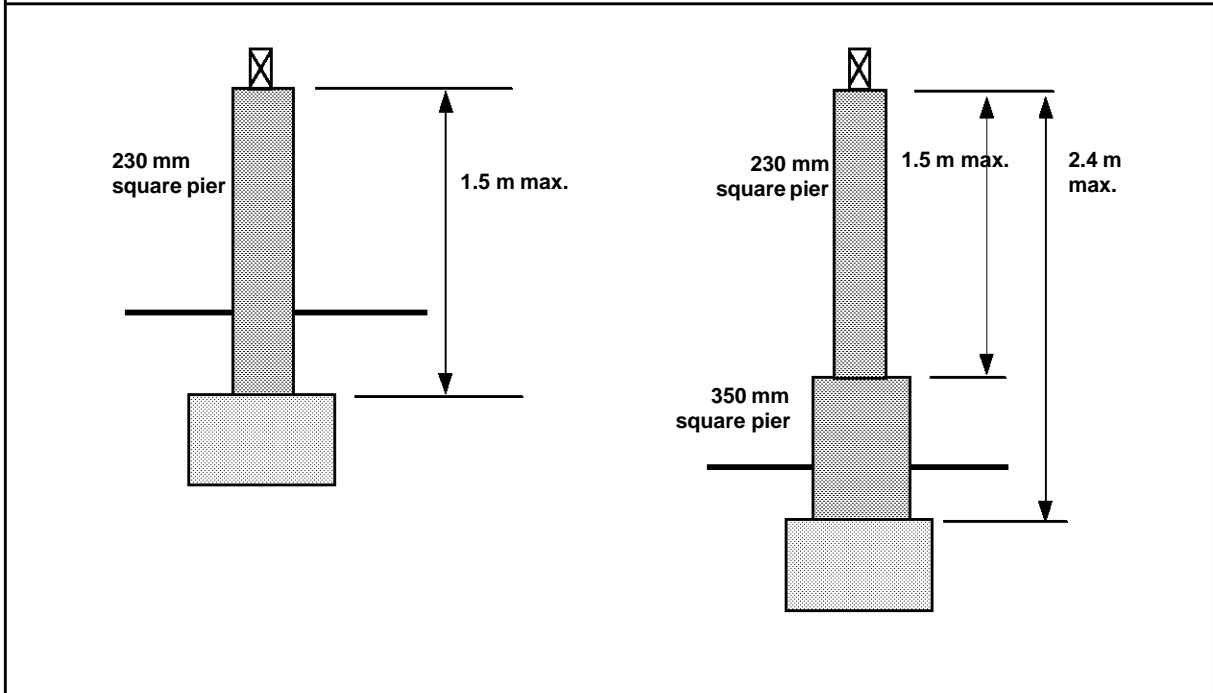

3.3.1.5 Masonry units

- (a) Mixing of clay with concrete or calcium silicate masonry panels for walling is not permitted; unless-
 - (i) at vertical junctions, a control joint is installed; and
 - (ii) at horizontal junctions, a slip joint using a membrane similar to that used for damp-proof courses is installed between the panels of the two different materials.
- (b) Masonry units must be classified and used in the exposure conditions appropriate to their classification as described in Table 3.3.1.1.

Table 3.3.1.1	
EXPOSURE CONDITIONS	
CLASSIFICATION	APPLICATION
Protected (PRO)	Suitable for use above damp-proof course provided they are protected at the top of the wall by appropriate roofs, eaves, copings or toppings in- <ul style="list-style-type: none"> (a) internal walls; and (b) coated or rendered <i>external walls</i>
General purpose (GP)	Suitable for all uses except exposure class
Exposure Class (EXP)	Suitable for use in all classifications including severe local conditions such as: <ul style="list-style-type: none"> (a) Below the damp-proof course in areas where walls are expected to be attacked by salts in the ground water or brickwork itself (salt attack or salt damp). (b) On sea fronts where walls are exposed to attack from salt spray, or in heavily polluted areas subject to deposition of atmospheric pollution (further protection may be required in severe environments). (c) In retaining walls. (d) Under regular cyclic freeze and thaw conditions.

3.3.1.6 Mortar mixes

Mortar used for masonry construction must-

- (a) comply with AS 3700; and
- (b) be mixed by volume in the proportions stated in Table 3.3.1.2; and
- (c) contain fine aggregate sand with low clay content and free from efflorescing salts; and
- (d) contain water which is potable (drinkable).

Table 3.3.1.2 MORTAR MIXES Note: Additives may be used provided they comply with the appropriate specified rate.		
BRICK CLASSIFICATION (as per Table 3.3.1.1)	MORTAR MIXED BY VOLUME Cement: Lime: Sand	
	General use	Suitable for concrete masonry - requires the use of methyl cellulose water thickener
Protected	1:2:9	1:0:5
General purpose	1:1:6	1:0:5
Exposure class	1:0.5:4.5	1:0:4

Amdt 3

3.3.1.7 Mortar joints

- (a) Unless otherwise specified masonry bed and *perpend* joints are to be a nominal 10 mm.
- (b) Where raked joints are used they must not be-
 - (i) deeper than 10 mm; or
 - (ii) used in saline environments or areas subject to heavy industrial air-borne pollution.

3.3.1.8 Vertical articulation joints

- (a) Vertical articulation joints must be provided in *unreinforced masonry* walls except walls built where the *site* soil classification is A or S (see Part 3.2.4).
- (b) Articulation joints must have a width not less than 10 mm and be provided (see Figure 3.3.1.7)-
 - (i) in straight, continuous walls having no openings, at not more than 6 m centres and not closer than the height of the wall away from corners; and
 - (ii) where the height of the wall changes by more than 20%, at the position of change in height; and
 - (iii) where openings more than 900x900 mm occur, at not more than 5 m centres, and positioned in line with one edge of the opening; and
 - (iv) where walls change in thickness; and
 - (v) at control or construction joints in footing slabs; and

- (vi) at junctions of walls constructed of different masonry materials; and
- (vii) at deep chases (rebates) for service pipes.

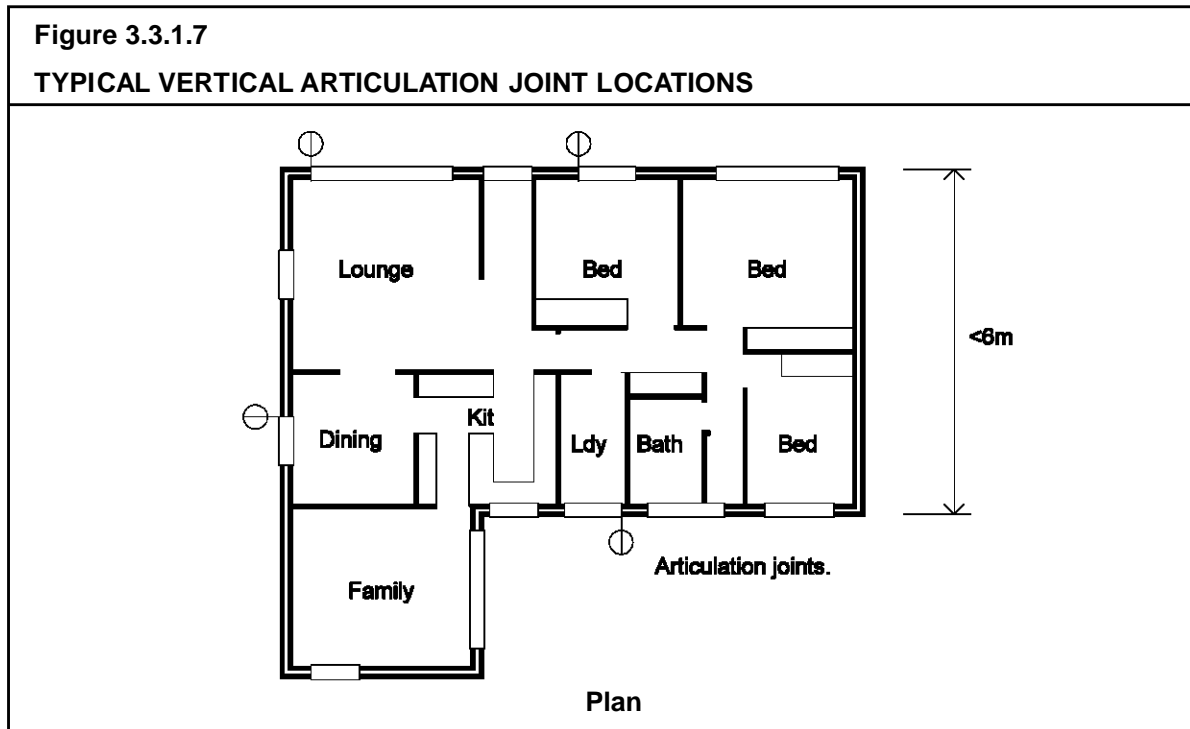

- (c) For all articulation joints in *cavity* walls, extendable masonry anchors must be built in at every fourth course (see Figure 3.3.1.9). For veneer construction the extendable ties may be omitted.
- (d) Where articulation joints are adjacent to door or window frames, a 10 mm gap must be left between the edge of the frame and the masonry to allow for movement (see Figure 3.3.1.9).
- (e) For single leaf masonry walls stabilised by return walls, or *engaged piers*, any articulation joints must be within 300 mm of the vertical support (see Figures 3.3.1.3, and 3.3.1.4).
- (f) All joints in single skin masonry must be sealed with a flexible, compressible material (see Figure 3.3.1.9).
- (g) Articulation joints constructed adjacent to arched openings must be constructed with minimum abutments between the opening and the articulation joint, in accordance with the Cement and Concrete Association of Australia - Technical Note 61.

Explanatory information: Design for other masonry wall types

The above design criteria are typical for clay masonry construction. Alternative designs may be appropriate and consideration should be given to a number of important factors to achieve an effective system, including-

- (a) expected soil movement - based on soil engineer's report; and
- (b) expected masonry unit growth - based on manufacturer's specifications; and
- (c) construction of wall ie openings, length of wall, height.

For more detailed requirements for articulation joints, refer to the Cement and Concrete Association Construction Technical Note 61.

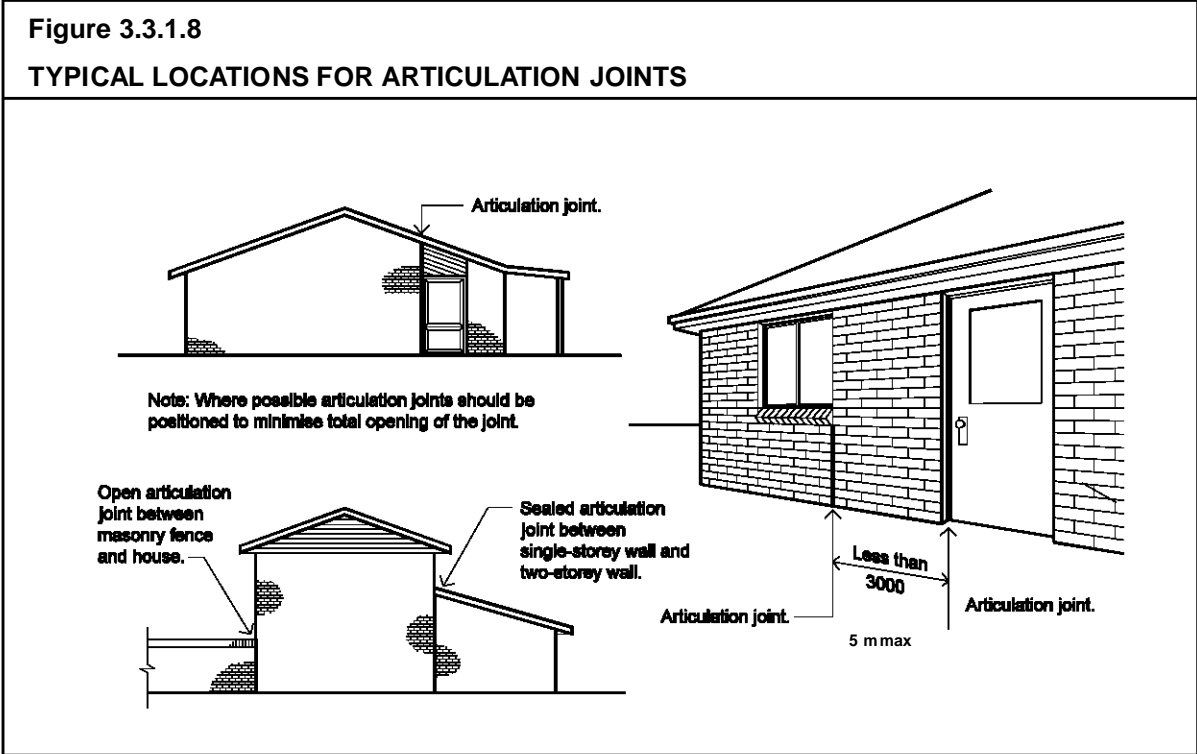

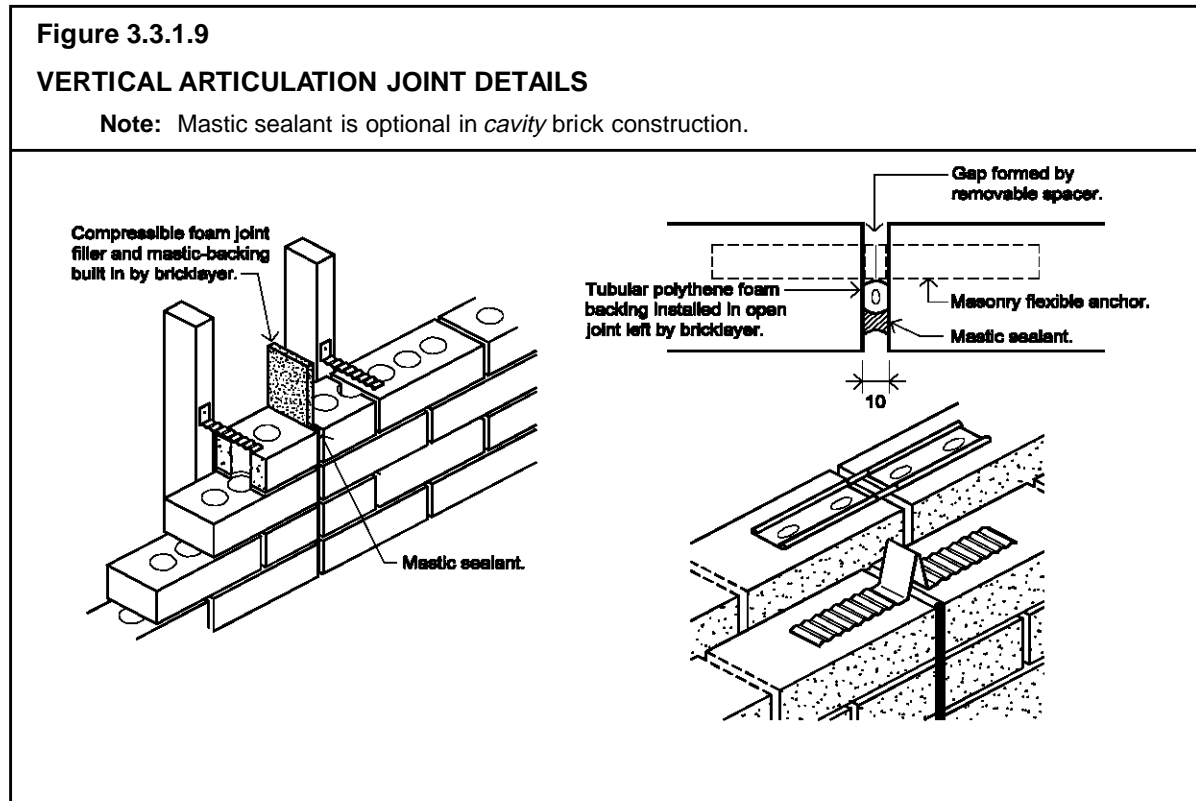
**3.3.1.9 Sub-floor ventilation**

Ventilation under suspended floors must be in accordance with Part 3.4.1.

3.3.1.10 Shrinkage allowance for timber framing

- (a) In masonry veneer walls a gap must be left between the timber frame and the top of the masonry wall, including *window* sills etc, to allow for settlement of the timber framing caused by timber shrinkage. These clearances must be not less than-
- (i) 5 mm at sills of lower and single storey windows; and
 - (ii) 8 mm at roof overhangs of single storey buildings; and
 - (iii) 10 mm at sills of second storey windows; and
 - (iv) 12 mm at roof overhangs to two storey buildings.
- (b) The clearances described in (a) must be doubled if the timber framing is unseasoned hardwood.

PART 3.3.2 REINFORCED MASONRY

Appropriate *Performance Requirements*:

Where an alternative *reinforced masonry* system is proposed to that described in Part 3.3.2, that proposal must comply with *Performance Requirement P2.1* in Section 2.

A. Acceptable construction manual

3.3.2.0 *Performance Requirement P2.1* is satisfied for *reinforced masonry* if it is designed and constructed in accordance with AS 3700 Masonry Code.

Explanatory information:

Design requirements for other materials that may be used in combination with masonry (heavy steel support beams etc). are described in Part 3.11 - Structural design.

B. Acceptable construction practice

3.3.2.1 Application

Compliance with this Part satisfies *Performance Requirement P2.1* for *reinforced masonry*, provided-

- (a) the *reinforced masonry* is constructed on footings that comply with Part 3.2; and
- (b) the building is located in an area with a *design wind speed* of not more than W41; and

Explanatory Information:

1. Information on *design wind speeds* for particular areas may be obtained from the *appropriate authority*.
2. Masonry walls in an area with a *design wind speed* of more than W41 should be designed in accordance with AS 3700 or Part 3.10.1.

- (c) for earthquake design, the building is defined as a design category H1 or H2 domestic structure in accordance with AS 1170.4; and

Explanatory Information:

1. This covers all *sites* except those identified by the site investigation as having soft soil (having a soil profile with more than 5 m of soft clay, loose sand, silt or uncontrolled fill) as defined by AS 1170.4.
2. For earthquake design H3, see AS 3700.

- (d) the building is not constructed in an *alpine area*.

3.3.2.2 External wall construction

Reinforced masonry external walls must consist of masonry units complying with AS 3700 and constructed in accordance with the following (see also Figure 3.3.2.1):

- (a) The *external wall* thickness must not be less than 140 mm.
- (b) Tie down rods must be provided and be-
 - (i) not less than one Y12 steel reinforcing bar (or equivalent); and
 - (ii) spaced at not more than 1.8 m centres between openings; and
 - (iii) fully grouted into the block work with a grout having a characteristic compressive strength of 20 MPa; and
 - (iv) lapped with cogged steel starter bars of a size not less than the tie down rods, set 250 mm into the concrete edge beam or footing in accordance with Figure 3.3.2.1.

Amdt 3

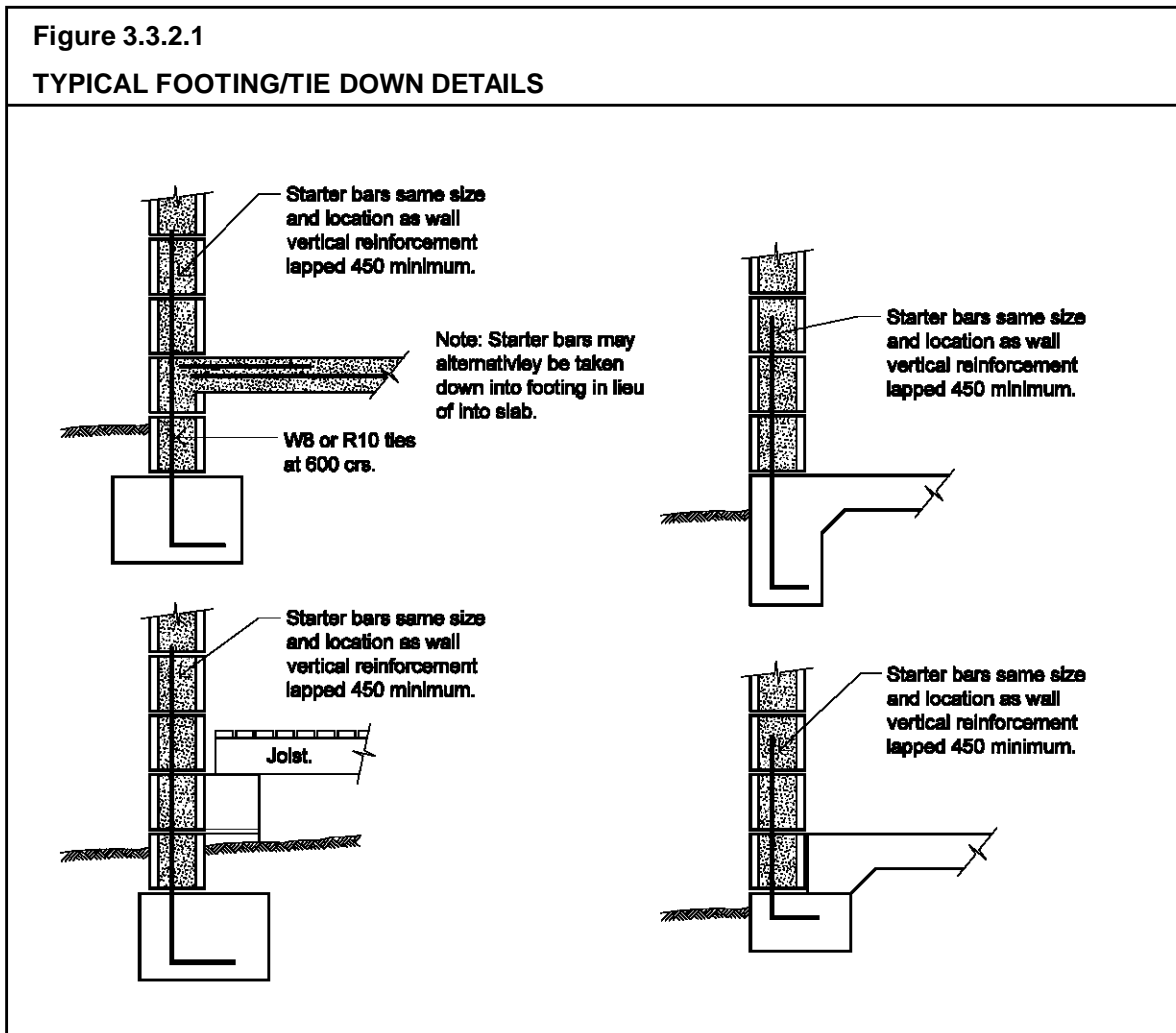

- (c) A continuous reinforced concrete *bond beam* must-
 - (i) be installed at the top of the walls in accordance with Figure 3.3.2.2 and Figure 3.3.2.3; and
 - (ii) have not less than two Y12 bars set in concrete grout with a characteristic compressive strength of 20 MPa; and
 - (iii) at door and *window* openings the *bond beam* may serve as a lintel supporting the roof trusses, provided additional reinforcement is placed in accordance with Figure 3.3.2.4; and
 - (iv) at first floor level a one course *bond beam* must be constructed in accordance with Figure 3.3.2.2.
- (d) All cores in masonry hollow block work below ground level must be filled with concrete grout.

Amdt 3

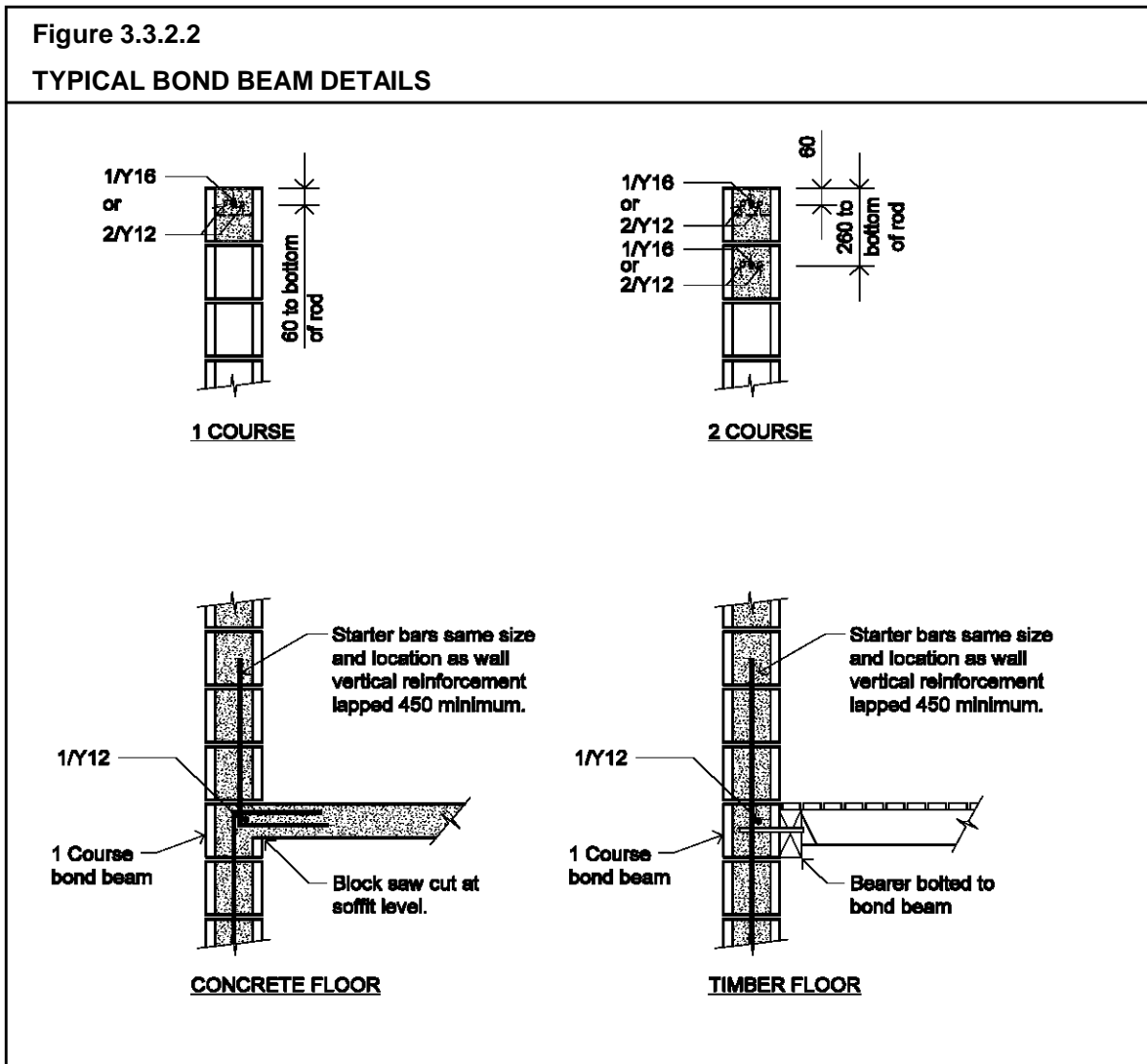

- (e) Lintels must be installed in accordance with the following:
 - (i) Lintels must be supported on reinforced piers in accordance with Table 3.3.2.1 (where appropriate).
 - (ii) Lintels carrying roof loads must be constructed in accordance with the appropriate requirements of Figure 3.3.2.3 and Figure 3.3.2.4.

Table 3.3.2.1
ADDITIONAL WALL PIER REINFORCING

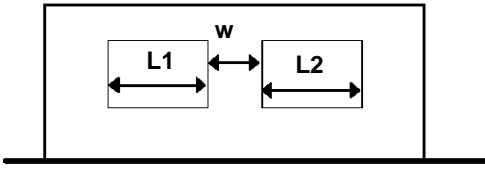

MAXIMUM SUM OF OPENINGS BESIDE PIERS "L1 + L2"				
ALL CORES REINFORCED WITH ONE Y12 ROD			END CORES ONLY REINFORCED WITH Y12 ROD	
WIDTH OF PIER "W" (mm)			WIDTH OF PIER "W" (mm)	
200	400	600	600	800
4000	6000	6000	6000	6000

Amdt 3

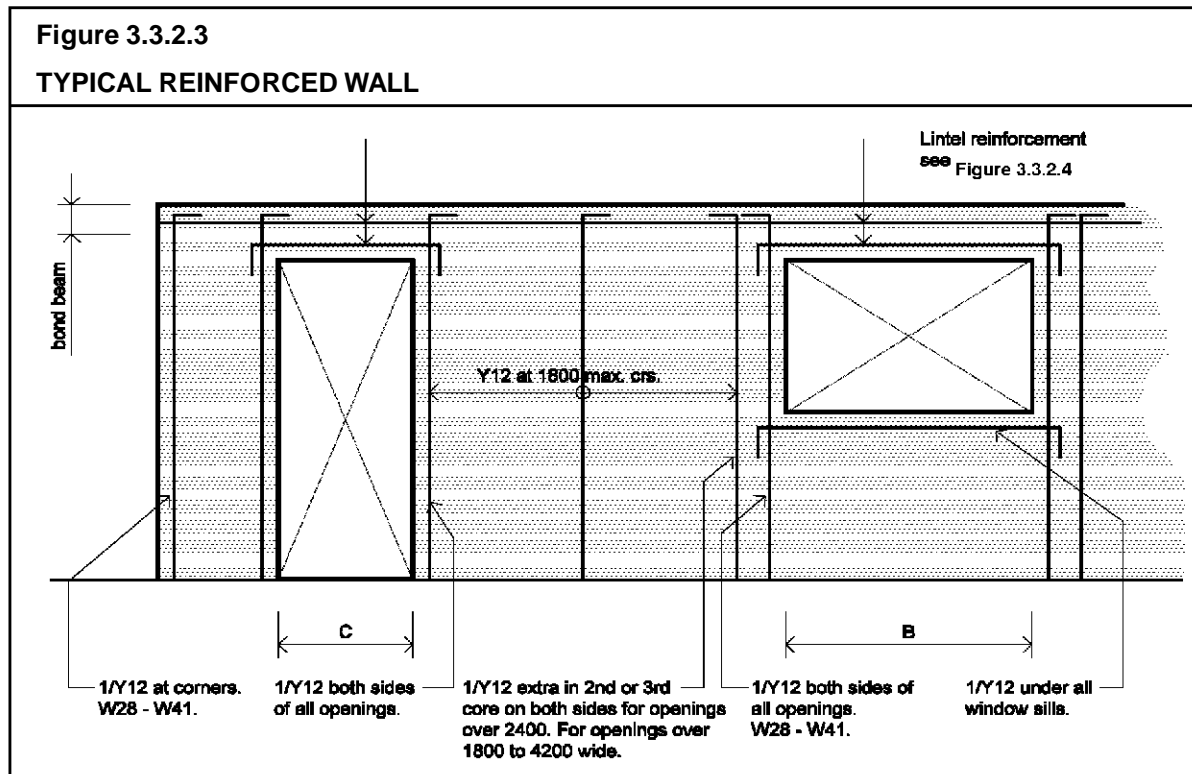

Figure 3.3.2.4
REINFORCEMENT AND CONSTRUCTION OF LINTELS

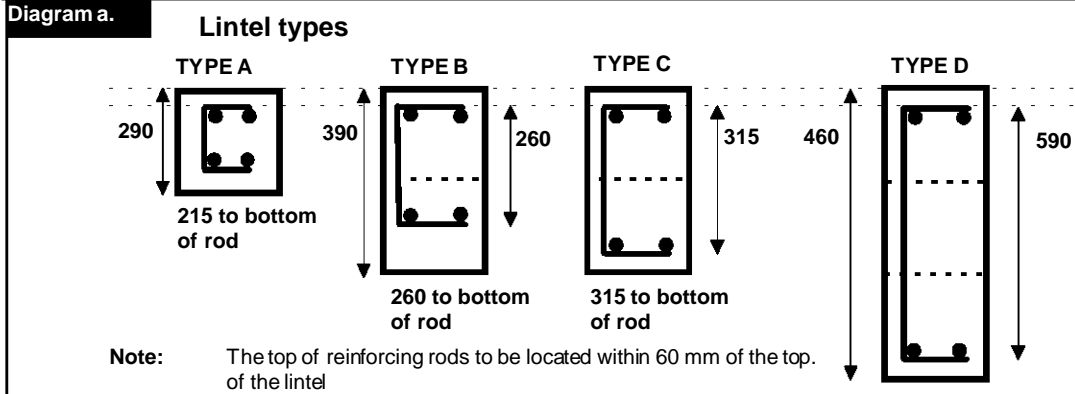

Table a. Reinforcement for lintel types

CODE				REINFORCEMENT	
A1	B1	C1	D1	2-Y12	Top and Bottom
A2	B2	C2	D2	1-Y16	Top and Bottom
A3S	B3S	C3S	D3S	2-Y12	Top and Bottom with W8 Stirrups @ 200 crs
A4S	B4S	C4S	D4S	1-Y16	Top and Bottom with W8 Stirrups @ 200 crs
A5	B5	C5	D5	2-Y16	Top and Bottom
A6S	B6S	C6S	D6S	2-Y16	Top and Bottom with W8 Stirrups @ 200 crs

Diagram b. Measurement of roof loads

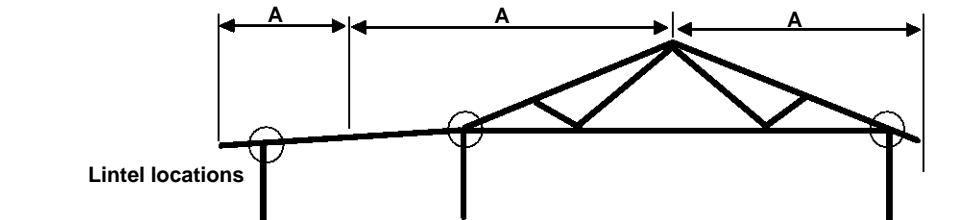

Table b. Lintel reinforcing for standard truss loading

Note: In lintels and bond beams using 2/Y12 bars, 1/Y16 bar may be used instead

OPENING (mm)	MINIMUM LINTEL REINFORCEMENT FOR STANDARD TRUSS LOADING								
	Maximum "A" - 4.6 m			Maximum "A" - 5.6 m			Maximum "A" - 6.6 m		
	LINTEL DEPTH (mm)			LINTEL DEPTH (mm)			LINTEL DEPTH (mm)		
	300	400	600	300	400	600	300	400	600
900	A1	B1 OR C1	D212	A1	B1 OR C1	D1	A1	B1 OR C1	D1
1200	A1	B1 OR C1	D212	A1	B1 OR C1	D1	A1	B1 OR C1	D1
1800	A1	B1 OR C1	D212	A1	B1 OR C1	D1	A3S	B1 OR C1	D1
2400	A1	B1 OR C1	D212	A3S	B1 OR C1	D1	A6S	B3S OR C1	D1
3000	A6S	B3S OR C1	D5	A6S	B6S OR C5	D1		B6S OR C66	D1
3600	-	B3S OR C5	D5		B6S OR C6S	D1		- C6S	D5
4200	-	- C6S	D5		- C6S	D5			D6
4800	-	- C6S	D5			D6			D6

- (f) Bracing walls must be installed in buildings to control lateral loading in accordance with the following:
 - (i) The walls must be constructed in accordance with Figure 3.3.2.5.
 - (ii) The permissible bracing capacity is determined in accordance with Table 3.3.2.2 after considering Figure 3.3.2.6.

Figure 3.3.2.5

TYPICAL BRACING WALL DETAILS

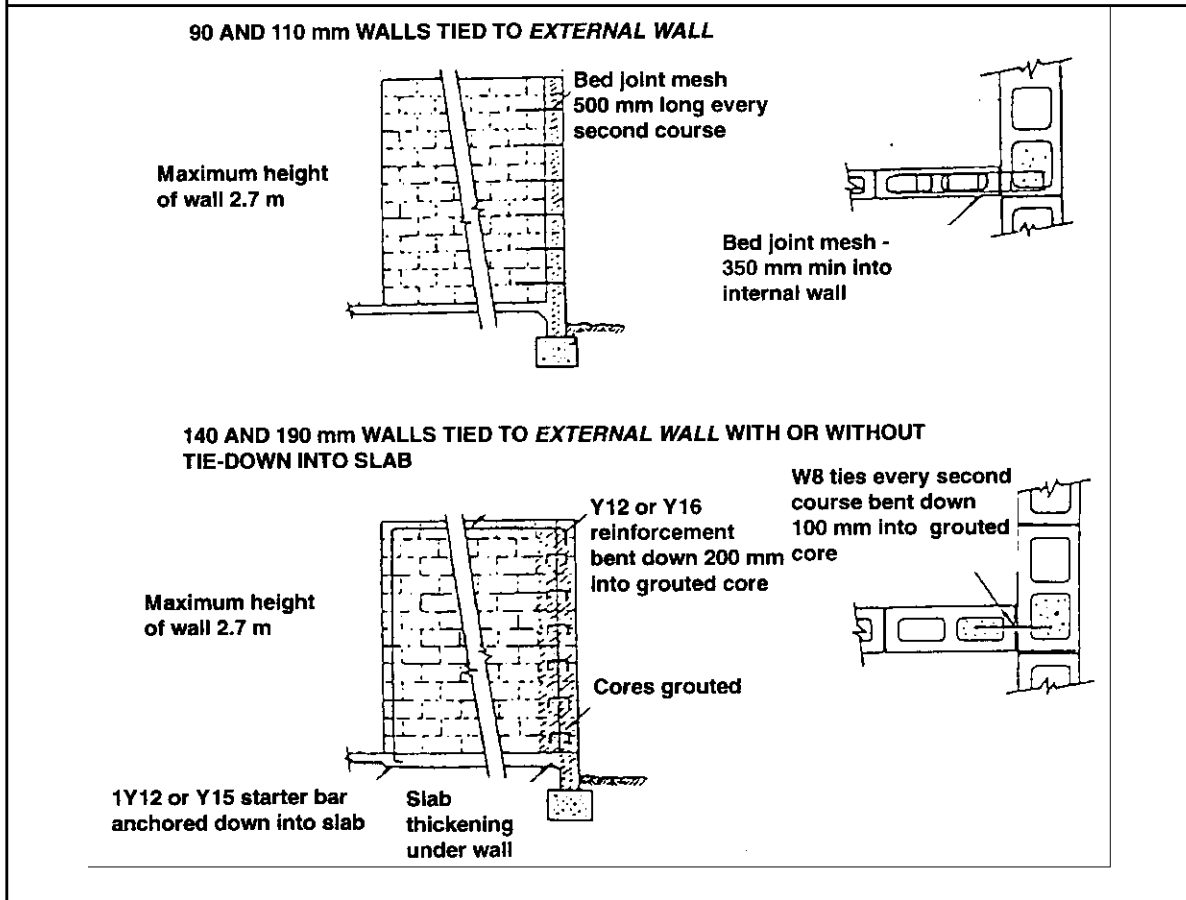

Amdt 3

Figure 3.3.2.6

IDENTIFYING WALL LENGTHS - (To be used with Table 3.3.2.2)

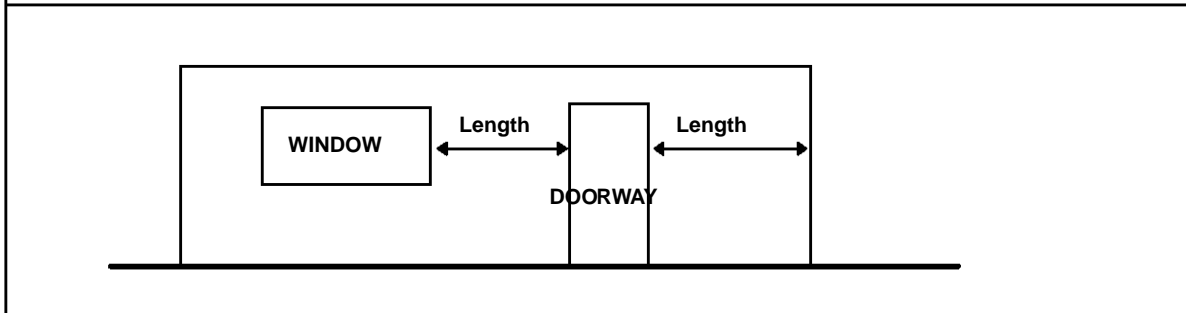

Table 3.3.2.2

BRACING CAPACITY OF WALLS 2.7 m HIGH

Note: Where a bracing wall is connected at only one end to a wall with a single course *bond beam*, the bracing value is limited by shear through the *bond beam* to 28.8 kN. Where it is necessary to use higher values a double *bond beam* must be used.

Wall Length (m)	PERMISSIBLE BRACING CAPACITY (kN)						
	90 mm & 110 mm Walls	140 mm Wall			190 mm Wall		
		No Tie down	Tie down size		No Tie down	Tie down size	
		Y12	Y16	Y12	Y16	Y16	
0.4	-	-	2.4	4.1	0.1	2.4	4.2
0.6	-	0.1	4.1	6.7	0.2	4.1	7.4
0.8	0.2	0.3	5.8	7.8	0.3	6.0	10.0
1.0	0.4	0.5	7.6	9.0	0.6	7.8	11.2
1.2	0.5	0.7	9.5	10.0	0.8	9.7	12.4
2.4	2.1	2.8	16.8	16.8	3.3	19.6	19.6
3.0	3.3	4.4	20.2	20.2	5.2	23.2	23.2
3.6	4.8	6.3	23.5	23.5	7.4	26.8	26.8
4.2	6.6	8.6	26.9	26.9	10.2	30.4	30.4
4.8	8.6	11.2	30.2	30.2	13.3	34.0	34.0
5.4	10.5	14.2	33.6	33.6	16.8	37.6	37.6
6.0	10.5	17.6	37.0	37.0	20.7	40.4	40.4

- (g) Roof trusses must be tied to the *reinforced masonry* wall with a method appropriate to the design strength nominated in Figure 3.3.2.7(a) or (b) after taking into consideration-
 - (i) the uplift force as determined in accordance with Table 3.3.2.3; and
 - (ii) the net design uplift pressure as determined in accordance with AS 4055 or AS 1170.2.

Amdt 3

Table 3.3.2.3
ROOF TRUSSES - UPLIFT FORCES

DESIGN WIND SPEED	NET DESIGN UPLIFT PRESSURE (kPa)		NET DESIGN UPLIFT FORCE ON STANDARD TRUSS (kN)								
			TRUSSES AT 600 mm SPACING			TRUSSES AT 900 mm SPACING					
	TILE ROOF	SHEET ROOF	TILE ROOF			TILE ROOF			SHEET ROOF		
			DIMENSION "A" (m)			DIMENSION "A" (m)			DIMENSION "A" (m)		
	4.6	5.6	6.6	4.6	5.6	6.6	4.6	5.6	6.6		
W33	0.00	0.42	0.0	0.0	0.0	0.0	0.0	0.0	1.7	2.1	2.5
W41	0.44	0.81	1.2	1.5	1.7	1.8	2.2	2.6	3.4	4.1	4.8

Note:

1. For a standard truss, the uplift force at each end is equal to the pressure multiplied by dimension "A" multiplied by the truss spacing.
2. Uplift forces for other values of dimension "A" may be interpolated.
3. Sheet roof includes metal tile.
4. Dimension "A" is determined in accordance with Figure 3.3.2.4 Diagram b.

Amdt 3

Figure 3.3.2.7(a)
TYPICAL TRUSS TIE DOWN METHODS USING THREADED ROD

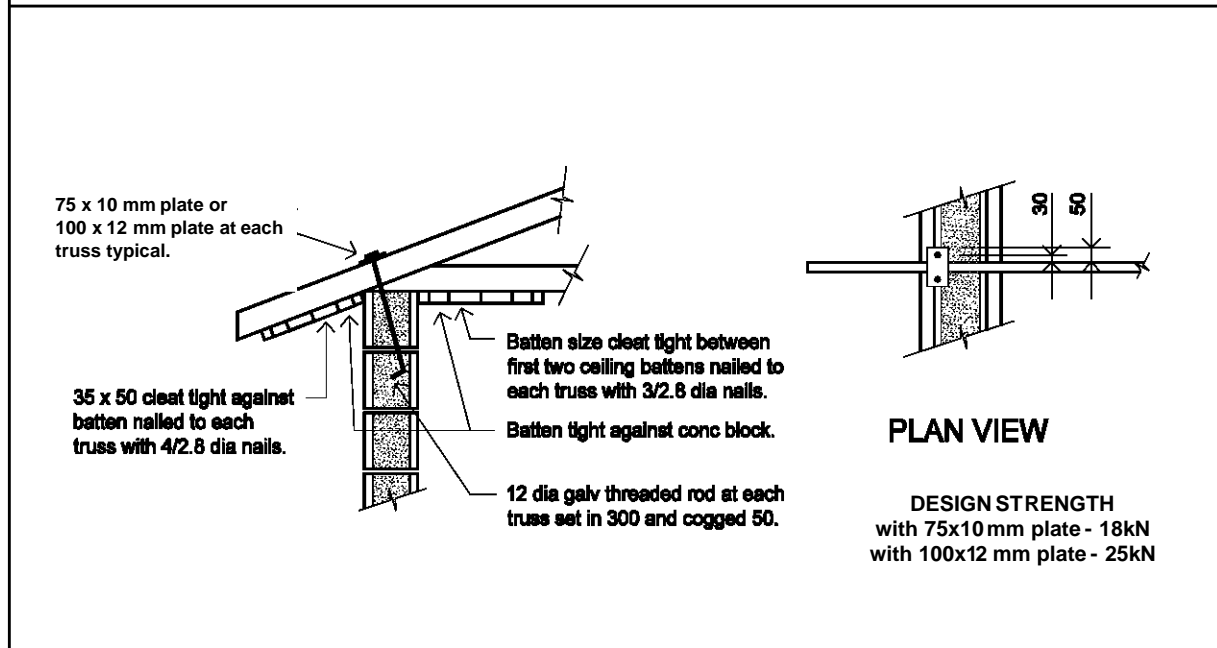
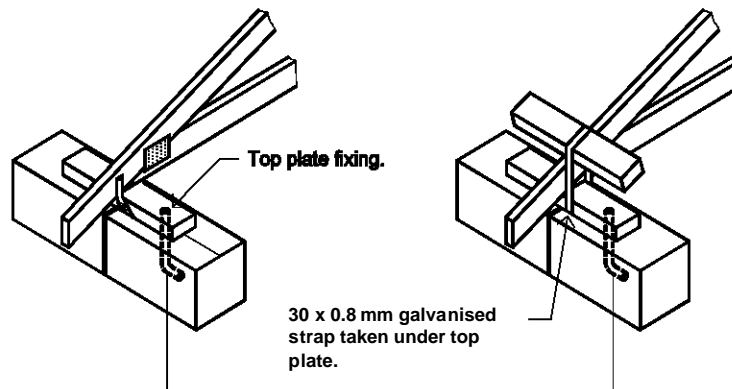

Figure 3.3.2.7(b)
TYPICAL TRUSS TIE DOWN METHODS - USING TOP PLATE



M12 bolt cast into *bond beam* within 100 mm of truss with J2, J3 or JD4 timber top plate
 Design strength with bolt anchored in top course - 12.5kN
 Design strength with bolt anchored below top course - 17kN

Amdt 3

Explanatory information:

Joint groups (J2, J3 and JD4) are a classification of the strength of a timber species for the purpose of joint design. Typically, mixed Australian grown softwoods are joint group JD4 and mixed hardwoods are joint group J2 or J3.

- (h) Gable ends to buildings must be constructed in accordance with one of the following:
 - (i) Where a timber frame is used above the *bond beam* the gable end must be supported by a ceiling diaphragm in accordance with Figure 3.3.2.8, Diagram a, by-
 - (A) anchoring the end truss to the wall; or
 - (B) bracing the end truss back to the internal trusses.
 - (ii) Where block work continues above the *bond beam*, fixed to the blockwork in accordance with Figure 3.3.2.8, Diagram b.

Figure 3.3.2.8

TYPICAL GABLE END CONSTRUCTION DETAILS

Diagram a.

Timber frame above *bond beam*

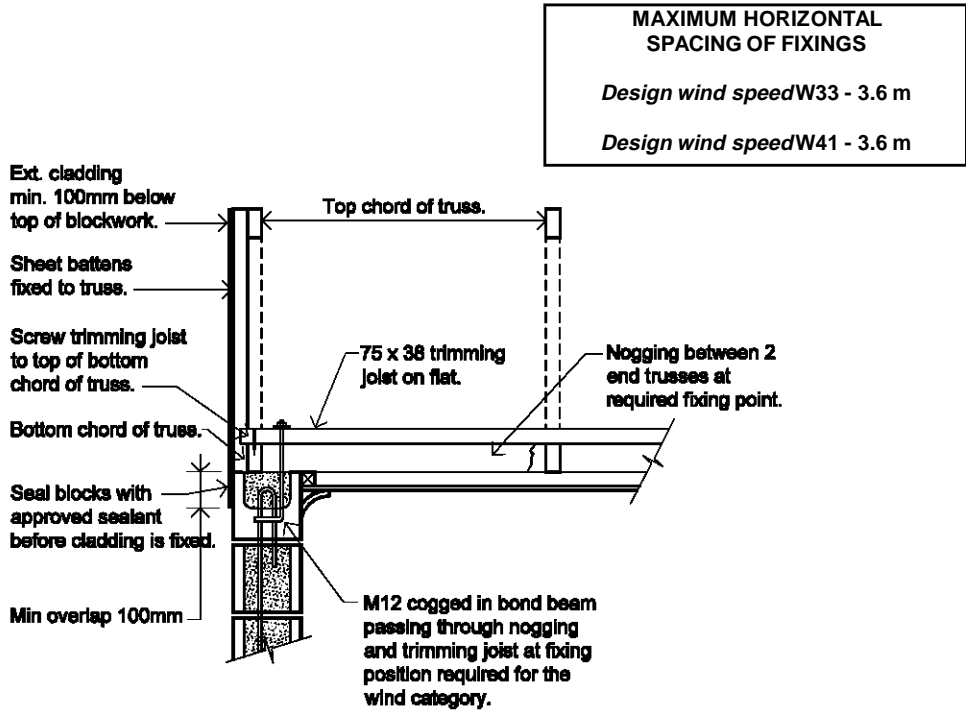
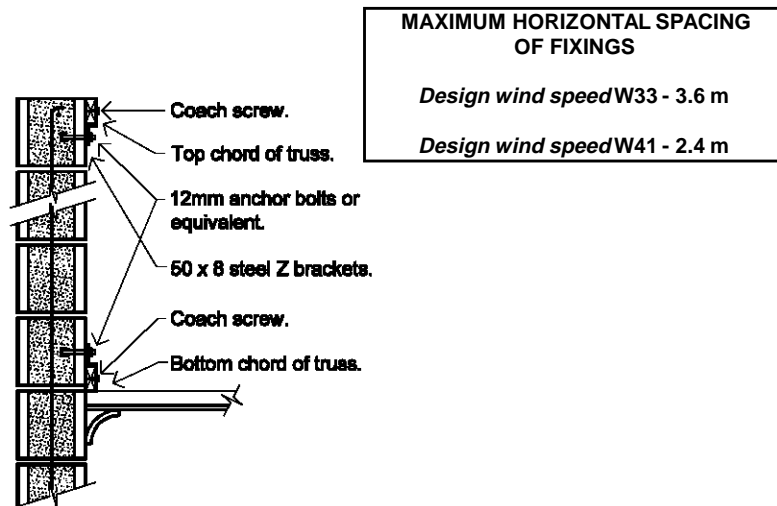

Diagram b.

Blockwork above *bond beam*



Amdt 3

PART 3.3.3 MASONRY ACCESSORIES

Appropriate *Performance Requirements*:

Where an alternative masonry accessory is proposed to that described in Part 3.3.3, that proposal must comply with *Performance Requirement P2.1* in Section 2.

A. Acceptable construction manual

3.3.3.0 *Performance Requirement P2.1* is satisfied for masonry accessories if they are constructed and installed in accordance with AS 3700 - Masonry Code.

B. Acceptable construction practice

3.3.3.1 Application

Compliance with this Part satisfies *Performance Requirement P2.1* for masonry accessories provided-

- (a) the building is located in an area with a *design wind speed* of not more than W41; and

Explanatory Information:

1. Information on wind speeds for particular areas may be available from the *appropriate authority*.
2. Masonry walls in an area with a *design wind speed* of more than W41 must be designed in accordance with AS 3700.

- (b) for earthquake design, the building is defined as a design category H1 or H2 domestic structure in accordance with AS 1170.4; and

Explanatory Information:

1. This covers all *sites* except those identified by the site investigation as having soft soil (having a soil profile with more than 5 m of soft clay, loose sand, silt or uncontrolled fill) as defined by AS 1170.4.
2. For earthquake design H3, see AS 3700.

- (c) the building is not constructed in an *alpine area*.

3.3.3.2 Wall ties

- (a) Masonry wall ties must be used to connect-
 - (i) masonry veneer wall cladding to a timber or metal *load bearing* frame complying with Part 3.4; and
 - (ii) the two leaves of *cavity* masonry; and
 - (iii) two leaves of masonry forming a single wall with no *cavity*; and
 - (iv) intersecting masonry walls at a joint where course bonding is not employed.
- (b) Masonry wall ties must comply with AS 3700.
- (c) Where articulation joints occur in masonry walls, ties must be built in both sides of the joint and spaced not more than 300 mm from the joint (see Figure 3.3.3.1).
- (d) Masonry wall ties must be installed in such a manner as to prevent moisture travelling along the tie to the inner leaf of masonry or frame.
- (e) Masonry veneer ties must be installed in accordance with Figure 3.3.3.1.
- (f) Wall ties must be classified in accordance with AS 2699 as light or medium duty and installed as follows:
 - (i) Light duty ties must not be used in veneer clad buildings in areas where the *design wind speed* is more than W33 and spaced in accordance with Figure 3.3.3.1 as if for medium duty ties.
 - (ii) Medium duty ties must be-
 - (A) for veneer and *cavity* construction - spaced in accordance with Figure 3.3.3.1; and
 - (B) for solid or monolithic construction, in accordance with (g).
- (g) Ties for solid or monolithic construction must be medium duty classification spaced not more than 400 mm in each direction and-
 - (i) the intersection of internal and external *cavity* or solid masonry walls must be bonded at the joint using medium duty ties at not more than 400 mm vertical spacing; and
 - (ii) in walls more than 200 mm in thickness, an additional tie is *required* within the spacing specified in (i) for every 200 mm of the thickness of the masonry units making the connection.
- (h) Masonry wall ties must be protected against corrosion in accordance with Table 3.3.3.1.

Figure 3.3.3.1

TYPICAL BRICK TIES SPACINGS IN CAVITY AND VENEER CONSTRUCTION

Note:

1. Solid masonry ties must be of a size appropriate to the *cavity* width and built not less than 50 mm into each leaf.
2. Wall tie spacings indicated on the diagram are indicative and may be reduced according to nature of the wall.
3. Location of wall ties immediately adjacent to ties connecting an intersecting wall may be increased to not more than 600 mm away from the intersecting wall ties.

Diagram a. - Spacing for medium duty wall ties - cavity and veneer construction

Legend: For the purposes of this diagram:

- Wall tie spacings halved
 Wall tie spacings as per Table a.

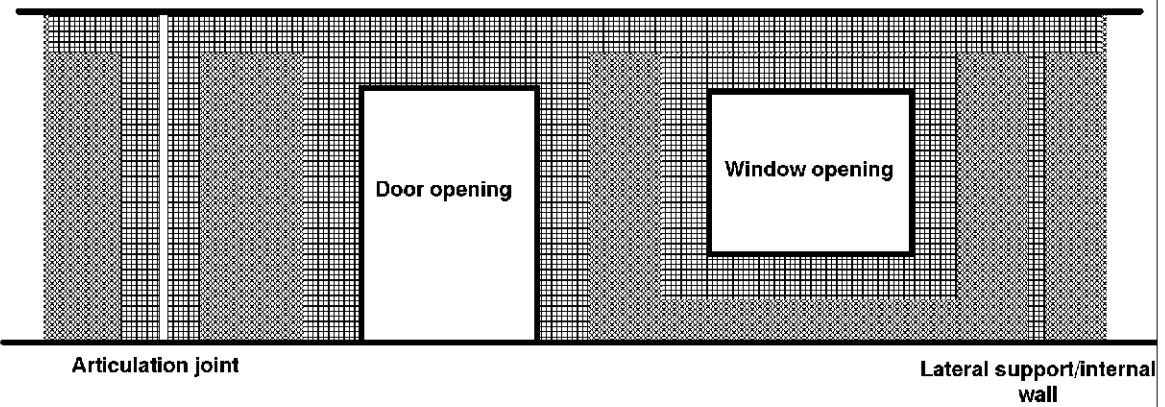

Table a. - Spacing for medium duty wall ties - cavity and veneer construction

DESIGN WIND SPEED (non-cyclonic)	CAVITY MASONRY	MASONRY VENEER CONSTRUCTION	
		450 STUD WALLS	600 STUD WALLS
W28 - W41	600 x 600	600 x 450	600 x 600

Note:

1. Inner leaf masonry thickness 70 to 150 mm for *cavity* walls.
2. Around openings and at control joints, the vertical tie spacings are halved (ie the number of ties must be doubled).
3. In veneer construction, masonry must be tied to stud wall framing at all regular stud positions, including gable ends.

Amdt 3

Table 3.3.3.1 CORROSION PROTECTION FOR WALL TIES Note: * - For Z classification, see 3.4.2.2.	
EXPOSURE CONDITION	TIE SPECIFICATION (corrosion protection)
All areas	<ul style="list-style-type: none"> • Galvanised sheet steel - at least Z600* • Galvanised wire - at least 470g/m² • Cadmium coated steel - at least Fe/Cd25C • Grade 316 stainless steel • Engineered polymer
Areas more than 1 km from the sea or not in heavy industrial areas	<ul style="list-style-type: none"> • Galvanised sheet steel - at least Z275 • Galvanised steel - coating class Type A (heavily galvanised) • Galvanised wire - at least 300g/m² • Cadmium coated steel - at least Fe/Cd12C • Engineered polymer

Amdt 3

3.3.3.3 Fixing straps and tie down systems

- (a) Timber door and *window* frames abutting masonry must be-
 - (i) fixed with 300 mm long 32x0.8 mm kinked galvanised steel straps; and
 - (ii) fixed to back of frames; and
 - (iii) set into courses not less than 150 mm at not more than 400 mm intervals.

- (b) For areas with a *design wind speed* of W28 or W33 and a roof system span of not more than 10 m, sheet metal and tiled roofs must be tied down using one of the following methods:
 - (i) 32x0.8 mm galvanised steel straps at not more than 1.2 m centres and corresponding with truss or rafter positions, looped around 10 mm diameter galvanised mild steel rods-
 - (A) built in across the *cavity* at a course not less than 900 mm below the top of the wall; and
 - (B) embedded not less than 50 mm into each leaf.

- (ii) 25x1 mm galvanised steel straps at not more than 1.2 m centres and corresponding with truss or rafter positions, built into the masonry inner leaf not less than 50 mm and 900 mm below the top of the wall, (see Figure 3.3.3.3).

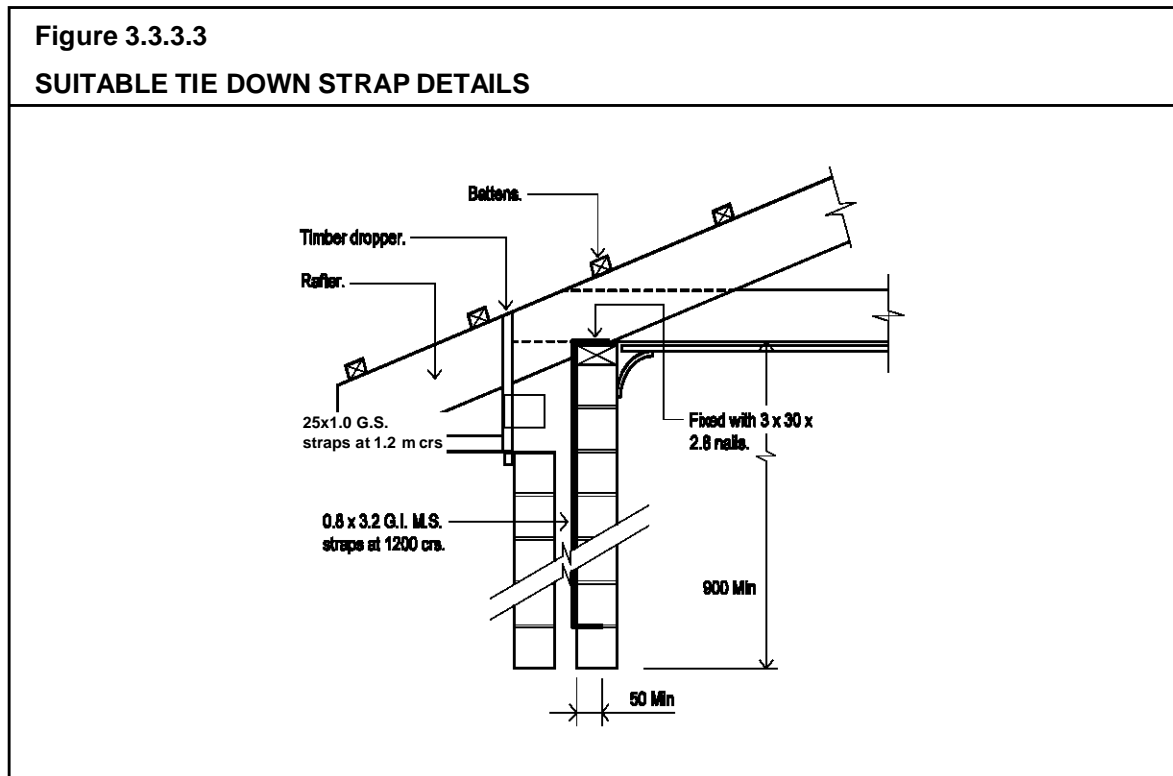

3.3.3.4 Lintels

- (a) Lintels in masonry must be-
- steel lintels complying with this Part; or
 - steel lintels complying with AS 4100, AS/NZS 4600; or
 - reinforced concrete beams designed in accordance with AS 3600.

Explanatory information:

Lintels that support structures other than masonry walls are covered in Section 3.4.4 - Structural steel members.

- (b) Steel lintels must comply with Figure 3.3.3.5 and-
- the long leg of angles must be vertical (see Figure 3.3.3.4); and
 - each angle or flat can carry a maximum 110 mm wall thickness; and
 - the minimum bearing length at each end of the lintel must be-

- (A) for clear spans less than 1 m - 100 mm; and
- (B) for clear spans more than 1 m - 150 mm (see Figure 3.3.3.4); and
- (iv) there must be not less than three courses of brickwork over openings; and
- (v) all loads must be uniformly distributed (point loads are not allowed).

3.3.3.4(c)
Amdt No. 3

- (c) Corrosion protection of lintels must be in accordance with Table 3.4.4.2.

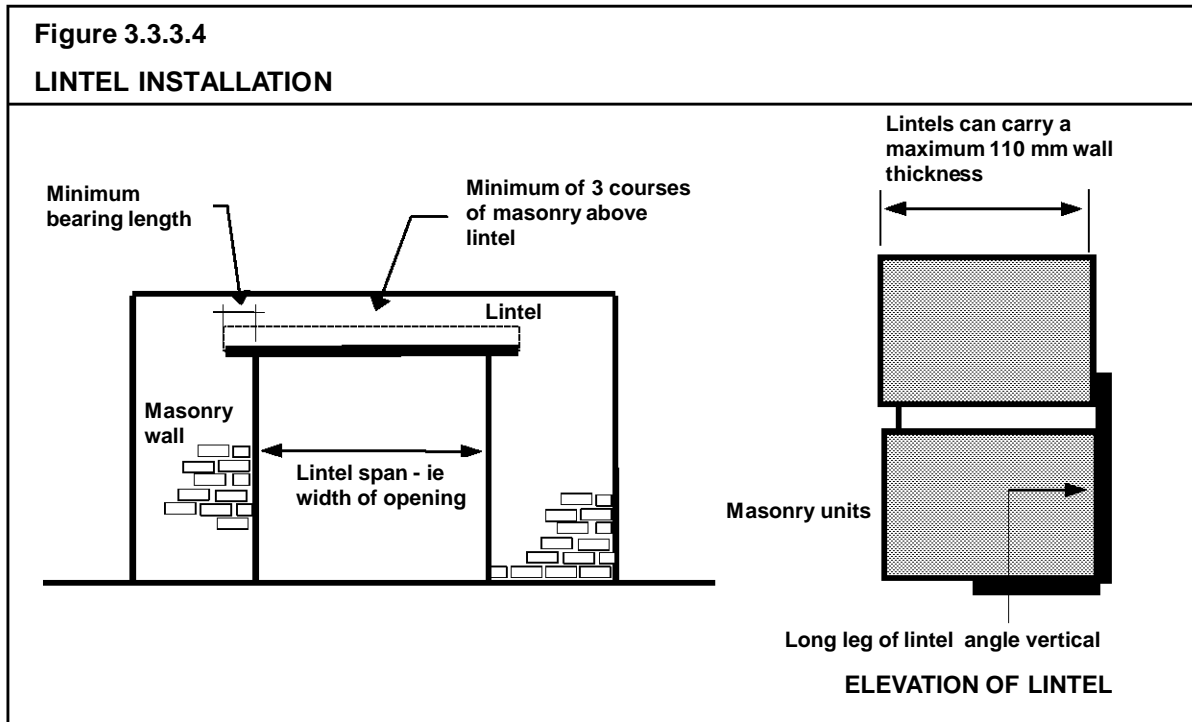

Amdt 3

Figure 3.3.3.5
LINTELS SUPPORTING ROOFS AND MASONRY WALLS

Diagram a. - Lintel types as described in Table a.

CONSTRUCTION TYPE A

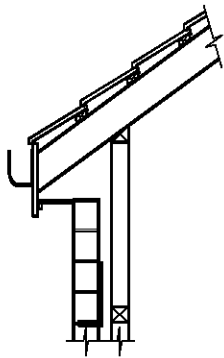

CONSTRUCTION TYPE B

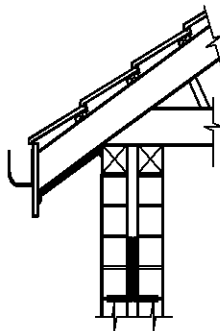

CONSTRUCTION TYPE C

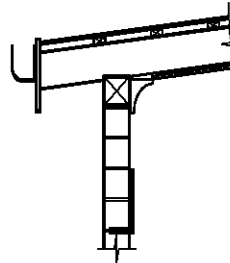

CONSTRUCTION TYPE D

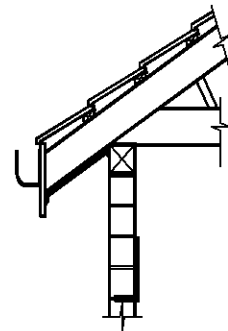

Table a. - Lintels spans

Design wind speed not more than W41 - Maximum roof span 10 m

Steel Section	Mass (kg/m)	Construction Type See Diagram a.			
		A	B	C	D
Angles		MAXIMUM CLEAR SPAN OF LINTEL (mm)			
90x90x6EA	8.22	3010	2050	2050	1570
90x90x8EA	10.6	3010	2170	2170	1810
100x100x6EA	9.16	3130	2290	2290	1810
100x100x8EA	11.8	3370	2410	2410	1930
150x90x8UA	14.3	4210	3370	3370	2770
150x100x10UA	18	4330	3490	3610	3010
Flats					
75x8	4.71	490	250	-	-
75x10	5.89	610	250	250	250

PART 3.3.4 WEATHERPROOFING OF MASONRY

Appropriate *Performance Requirements*:

Where an alternative weatherproofing system is proposed to that described in Part 3.3.4, that proposal must comply with *Performance Requirement P2.2.2* in Section 2.

Definitions

3.3.4 For the purposes of this Part:

DPC means damp-proof course.

A. Acceptable construction manual

3.3.4.0 *Performance Requirement P2.2.2* is satisfied for weatherproofing of masonry if it is carried out in accordance with the appropriate provisions of AS 3700.

B. Acceptable construction practice

3.3.4.1 Application

Compliance with this Part satisfies *Performance Requirement P2.2.2* for weatherproofing of masonry, provided the masonry wall is constructed in accordance with Part 3.3.1 or Part 3.3.2.

3.3.4.2 Width of Cavity

In brick veneer and *cavity* masonry construction, a *cavity* must be provided between the inner and outer walls as follows:

- (a) Brick veneer - not less than 25 mm width.
- (b) *Cavity* masonry - not less than 35 mm nor more than 65 mm width.
- (c) The minimum *cavity* width specified in (a) and (b) is to be maintained between the outer masonry leaf and any services, insulation, sheet bracing or other element located in the *cavity*.

3.3.4.3 Cavity ventilation and drainage

Open perpendicular joints (weepholes) must be created in the course immediately above any *DPC* or flashing-

- (a) at centres not exceeding 1.2 m; and
- (b) weepholes are not *required* for head or sill openings less than 1 m wide.

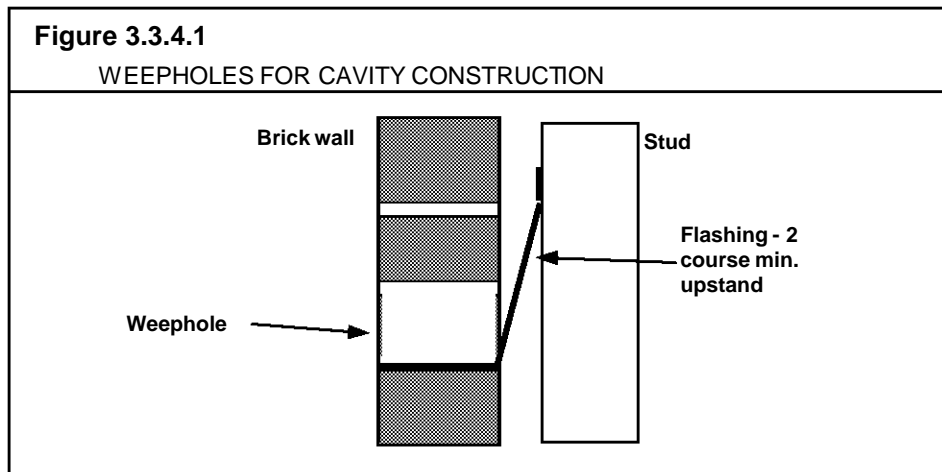

3.3.4.4 Damp-proof courses - materials

Damp-proof courses must consist of-

- (a) a material that complies with AS/NZS 2904; or
- (b) embossed black polyethylene film of high impact resistance and low slip, with a nominal thickness of 0.5 mm prior to embossing, and meeting the requirements of clause 7.6 of AS/NZS 2904; or
- (c) polyethylene coated metal, that has an aluminium core of not less than 0.1 mm thick, is coated both sides with bitumen adhesive enclosed in polyethylene film of not less than 0.1 mm thick on each face, and has a nominal total thickness of not less than 0.5 mm prior to embossing; or
- (d) bitumen impregnated materials of not less than 2.5 mm thickness, that meet the requirements of clause 7.5 of AS/NZS 2904, when used in walls which are not higher than 7.8 m above the level of the *DPC*; or
- (e) termite shields (with no penetrations) continuous through the wall or pier.

STATE AND TERRITORY VARIATIONS

In South Australia delete 3.3.4.4 and insert SA 3.3.4.4 as follows:

SA 3.3.4.4 Damp-proof courses - materials

Damp-proof courses must consist of-

- (a) embossed black polyethylene film meeting the requirements of clause 7.6 of AS/NZS 2904; or
- (b) polyethylene coated aluminium meeting the requirements of clause 7.4 of AS/NZS 2904; or
- (c) bitumen impregnated materials of not less than 2.5 mm thickness, meeting the requirements of clause 7.4 of AS/NZS 2904, when used in walls not higher than 7.8 m above the level of the damp-proof course.

3.3.4.5 Damp-proof courses - installation

- (a) *DPCs* must be located in accordance with Figure 3.3.4.4, and-
 - (i) where under external masonry walls on slabs or footings,-
 - (A) be of sufficient width to project past the external face of the wall; and
 - (B) be located to extend across the *cavity* and not less than 75 mm above floor level; and
 - (C) the top edge of the upstand must be fixed with clouts to each timber stud or built into internal masonry wall leaf as applicable; and
 - (ii) installed in all walls in solid masonry construction; and
 - (iii) where the *DPC* is also used as a termite shield it must extend 40 mm from the internal face of brickwork and may be flush on the external face of brickwork; and
 - (iv) installed where *required* to form a continuous damp proofing barrier around the building.
- (b) A *DPC* may also be used as a flashing to shed moisture to the outside (see 3.3.4.6).
- (c) The height of the *DPC* (or flashing) must be not less than 150 mm above adjacent finished paving or ground level.
- (d) *DPCs* must be stepped where a change in floor level occurs.

- (e) *DPCs* must be installed under the coping to parapets where the parapet is more than 300 mm above the adjoining roof cladding (see Figure 3.3.4.2).
- (f) In chimney stacks-
 - (i) the *DPC* must be installed between 150 mm and 300 mm above the highest point where the chimney meets the roof; or
 - (ii) two *DPCs* may be used to avoid a high flashing upstand (see Figure 3.3.4.3).
- (g) Lap joints in a *DPC* must be not less than 150 mm.

Figure 3.3.4.2

INSTALLATION OF DPCs FOR PARAPET WALLS

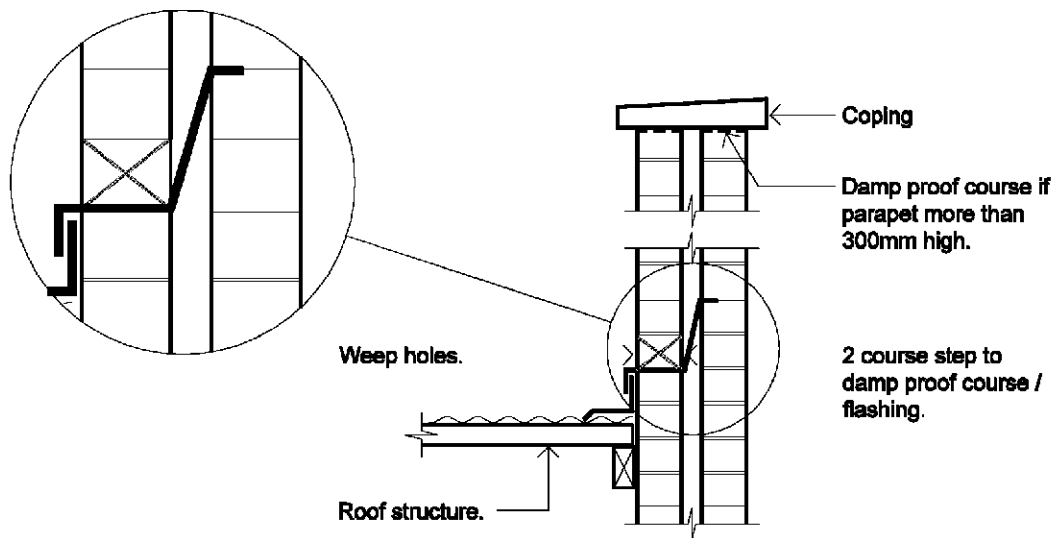

NOTE: To avoid electrochemical reactions, metal flashings must be compatible with all materials they are in contact with, and all materials where water runs from or onto the flashing.

Figure 3.3.4.3
CORRECT INSTALLATION OF DPC AND FLASHINGS IN CHIMNEYS

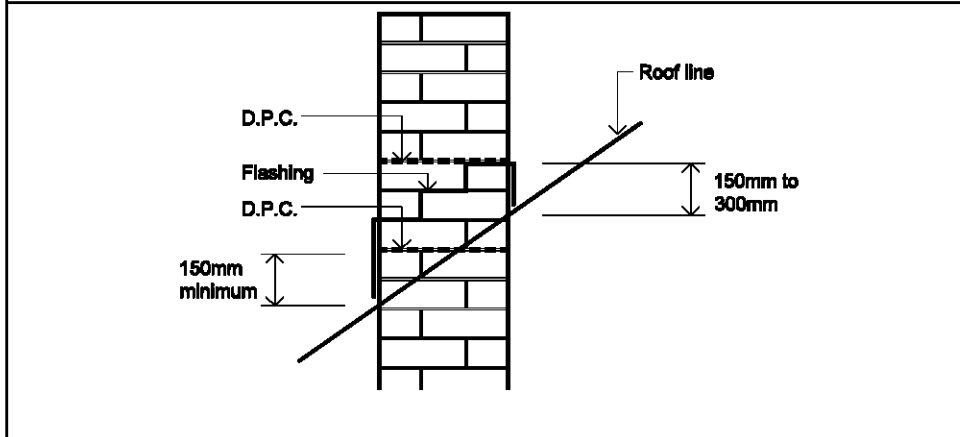

Amdt 3

Figure 3.3.4.4
CORRECT INSTALLATION OF DPC IN SUB-FLOOR STRUCTURES

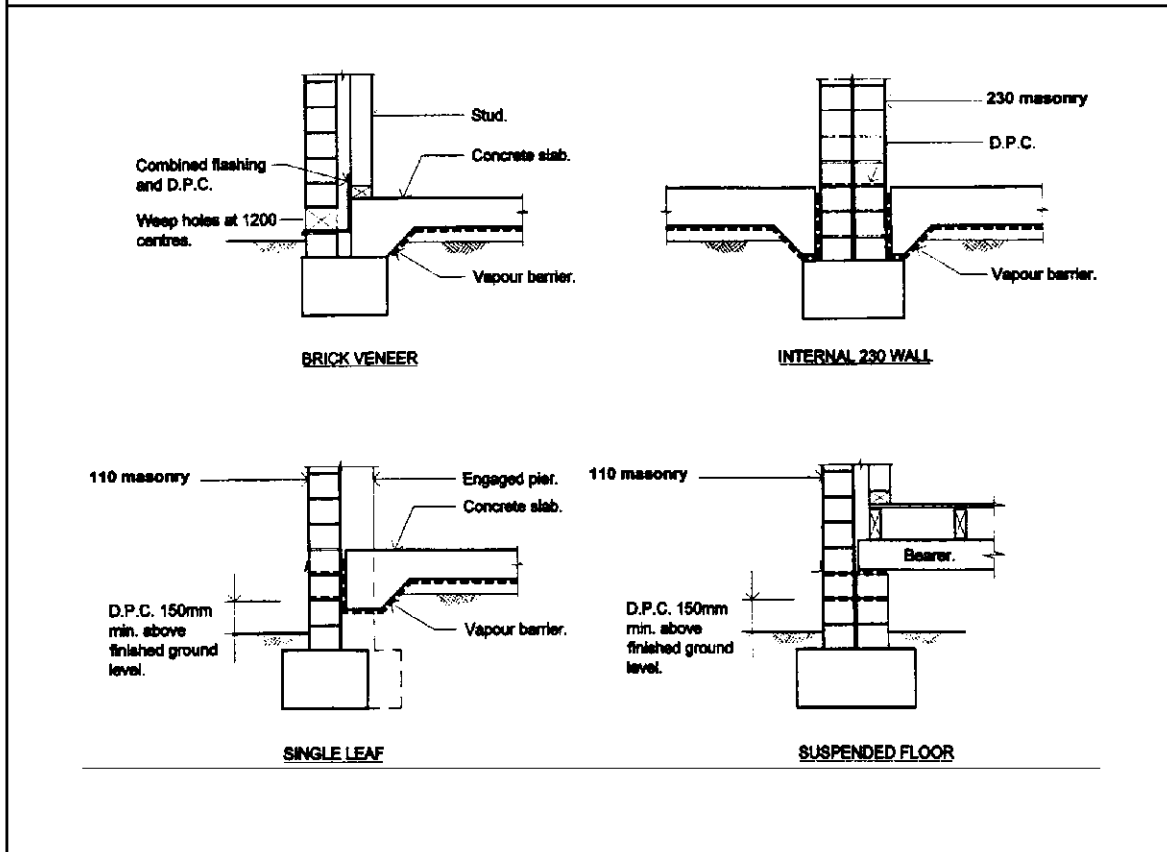

3.3.4.6 Flashings

- (a) Flashings must be manufactured in accordance with AS/NZS 2904 and-
 - (i) be built in as the work proceeds; and
 - (ii) where electrolytic action could otherwise occur, different materials must be isolated in accordance with Table 3.5.1.2; and
 - (iii) flashings near the base of walls and above ground may be used instead of a *DPC*.
- (b) Flashing materials must comply with Table 3.3.4.1.

Table 3.3.4.1
Amdt No. 3

Table 3.3.4.1	
SUITABLE FLASHING MATERIALS FOR INTERNAL AND EXTERNAL APPLICATIONS	
LOCATION	SUITABLE FLASHING MATERIAL
INTERNAL	<ul style="list-style-type: none"> • Uncovered copper having a mass of not less than 2.8 kg/m² and having a thickness of 0.3 mm to 0.5 mm • Bitumen coated metal (normally aluminium) with a total coated thickness of 0.6 to 1.00 mm • Zinc coated steel with a thickness of not less than 0.6 mm • Embossed/Quilted polyethylene sheet with an average thickness of not less than 0.5 mm. • Uncovered annealed lead having a mass of not less than 10 kg/m²
EXTERNAL Roof to masonry wall flashings	<ul style="list-style-type: none"> • Embossed/Quilted polyethylene sheet with an average thickness of not less than 0.5 mm. • Uncovered annealed lead having a mass of not less than 20 kg/m² in lengths not exceeding 1.5 m • Uncovered copper having a mass of not less than 2.8 kg/m² and having a thickness of 0.3 mm to 0.5 mm • Bitumen coated metal (normally aluminium) with a total coated thickness of 0.6 to 1.00 mm • zinc coated steel with a thickness of not less than 0.6 mm

- (c) Openings in masonry walls that are exposed to the weather must be flashed in accordance with the following, Figures 3.3.4.5 and 3.3.4.6 except where the frame around the opening is designed to weatherproof the opening:
 - (i) In veneer construction the flashing must extend across the *cavity* and be turned up not less than 150 mm and fixed to the frame.

Amdt 3

- (ii) For *cavity* masonry construction the flashing must extend across the *cavity* and be turned up not less than 150 mm and built 30 mm into the inner skin of brickwork.
- (iii) Flashings must extend 100 mm beyond each end of openings.
- (iv) The flashing at the top of that opening may be omitted where the opening is protected by eaves or the like with a width of not less than three times the distance between the top of the opening and the overhang (see Figure 3.3.4.4(a)).

3.3.4.6(c)(iv)
Amdt No. 3

Fig 3.3.4.4(a)
Amdt No. 3

Amdt 3

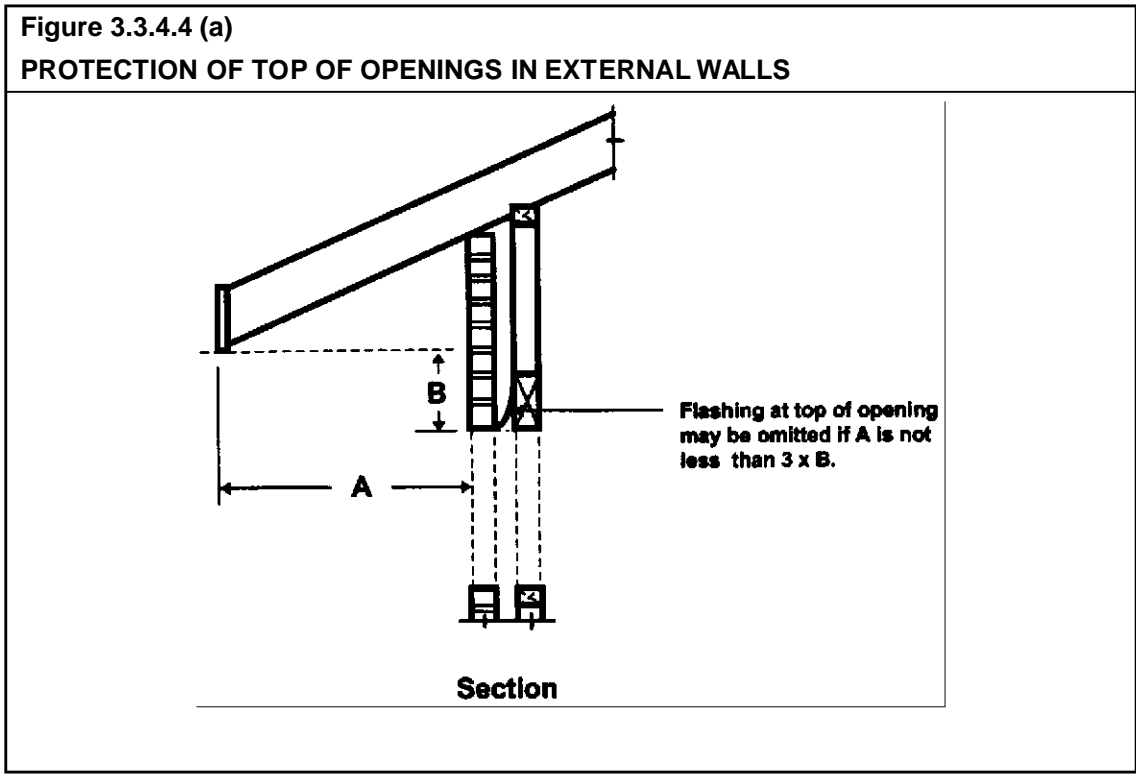
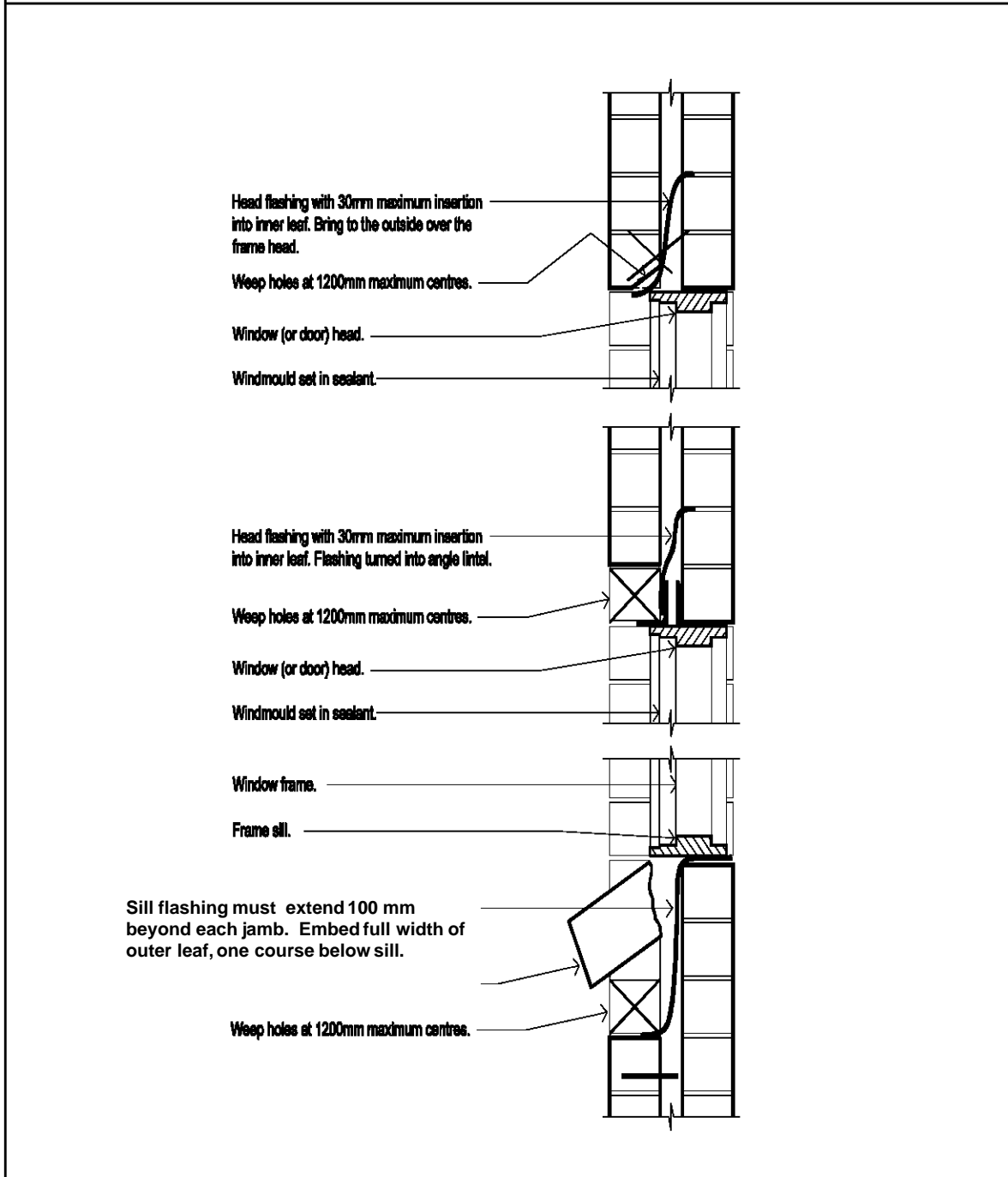

Figure 3.3.4.5

FLASHING OF OPENINGS IN CAVITY MASONRY WALLS



Amdt 3

Figure 3.3.4.6

FLASHING OF OPENINGS IN MASONRY VENEER WALLS

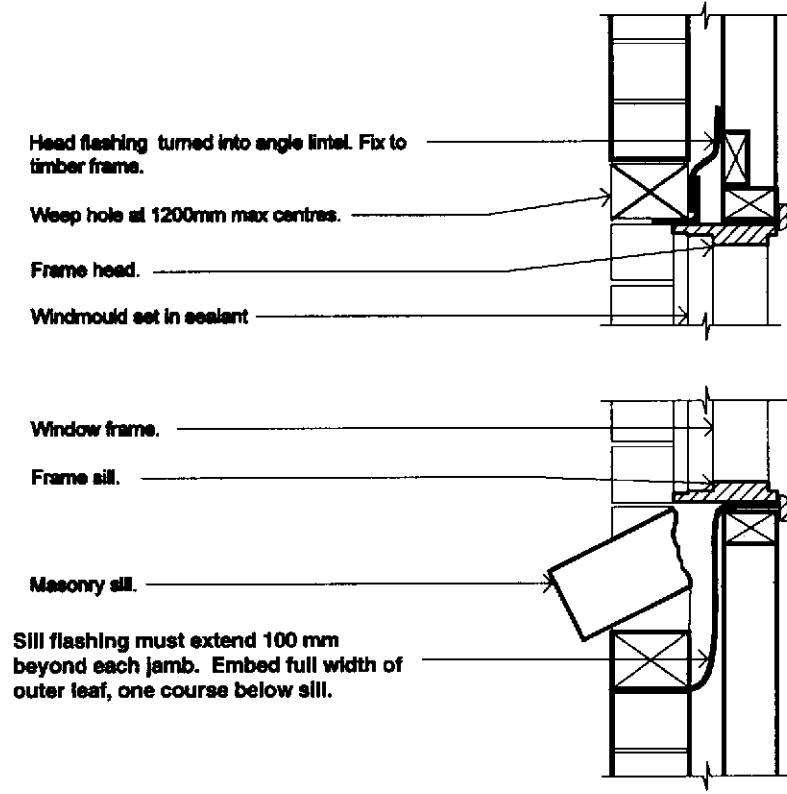

- (d) Flashing to ensure weatherproof construction must be continued onto any roof surface adjoining the masonry, including a porch, canopy or similar roof; and-
- (i) consist of a material that complies with Table 3.3.4.1; and
 - (ii) be installed in accordance with Figure 3.3.4.7 and Part 3.5.1; and
 - (iii) for *cavity* walls - stepped and scribed to suit the roof line and allowing not less than 75 mm in height and 150 mm in width for dressing onto roof material; and
 - (iv) for single leaf masonry - stepped or set into a groove power cut parallel to and approximately 150 mm above the line of the roofing material and scribed, riveted or sealed as necessary relative to adjacent roofing materials.

Figure 3.3.4.7

STEPPED CAVITY FLASHINGS

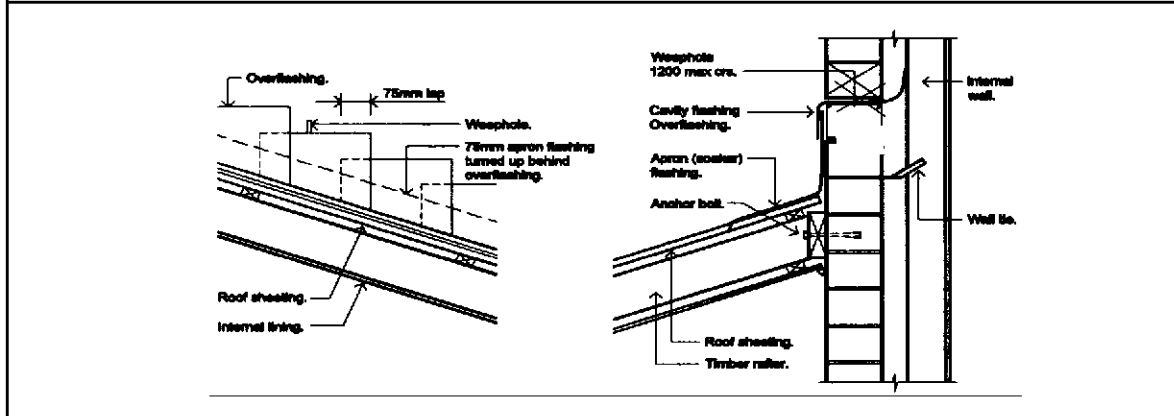

3.3.4.7 Weatherproofing for single skin masonry walls

- (a) A waterproof coating material must be applied to all external single skin masonry walls in accordance with the following:
- (i) The coating must extend from the upper most exposed part of the wall-
 - (A) to a level adjacent the internal finished floor level, if the external blockwork overhangs the edge of the slab 10 mm; or
 - (B) 50 mm below the internal floor level if no edge overhang is provided to the blockwork (see Figure 3.3.4.9).
 - (ii) Acceptable external waterproof finishes are-
 - (A) three coats of 100% acrylic based exterior quality gloss paint; or
 - (B) one complete coat of cement based paint and two coats of 100% acrylic based exterior quality gloss paint; or
 - (C) clear water repellent, provided the wall is protected by a roof overhang.
- (b) *Windows* must be installed in accordance with Figure 3.3.4.8.
- (c) A damp-proof course and vapour barrier or damp-proofing membrane must be installed in accordance with Figure 3.3.4.9.

Limitation:

3.3.4.7 does not apply to a Class 10 building where in the particular case there is no necessity for compliance.

Figure 3.3.4.8

TYPICAL WINDOW INSTALLATION DETAILS FOR SINGLE SKIN MASONRY

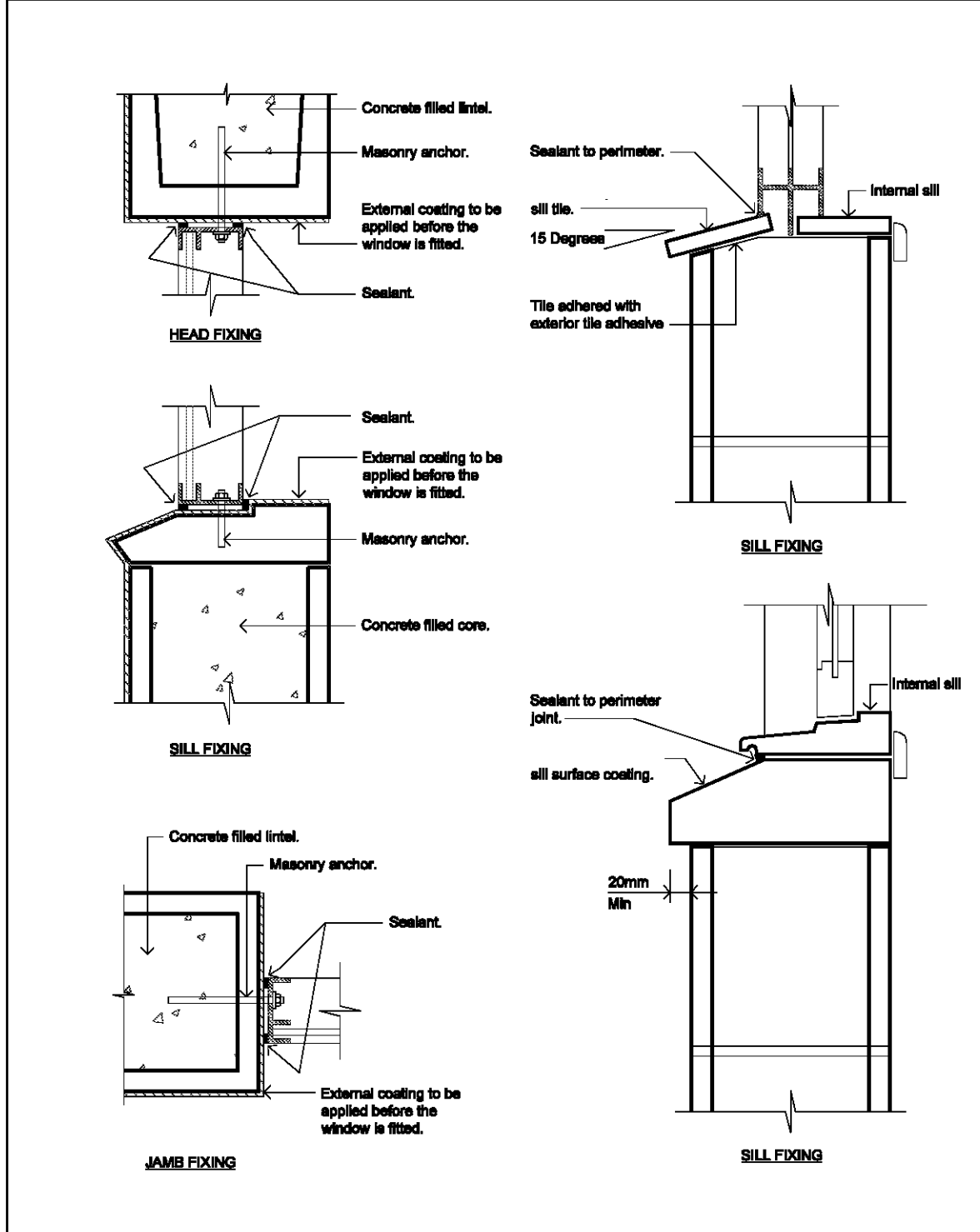

Amdt 3

Figure 3.3.4.9

TYPICAL DPC AND WEATHERPROOFING DETAILS FOR SINGLE SKIN MASONRY

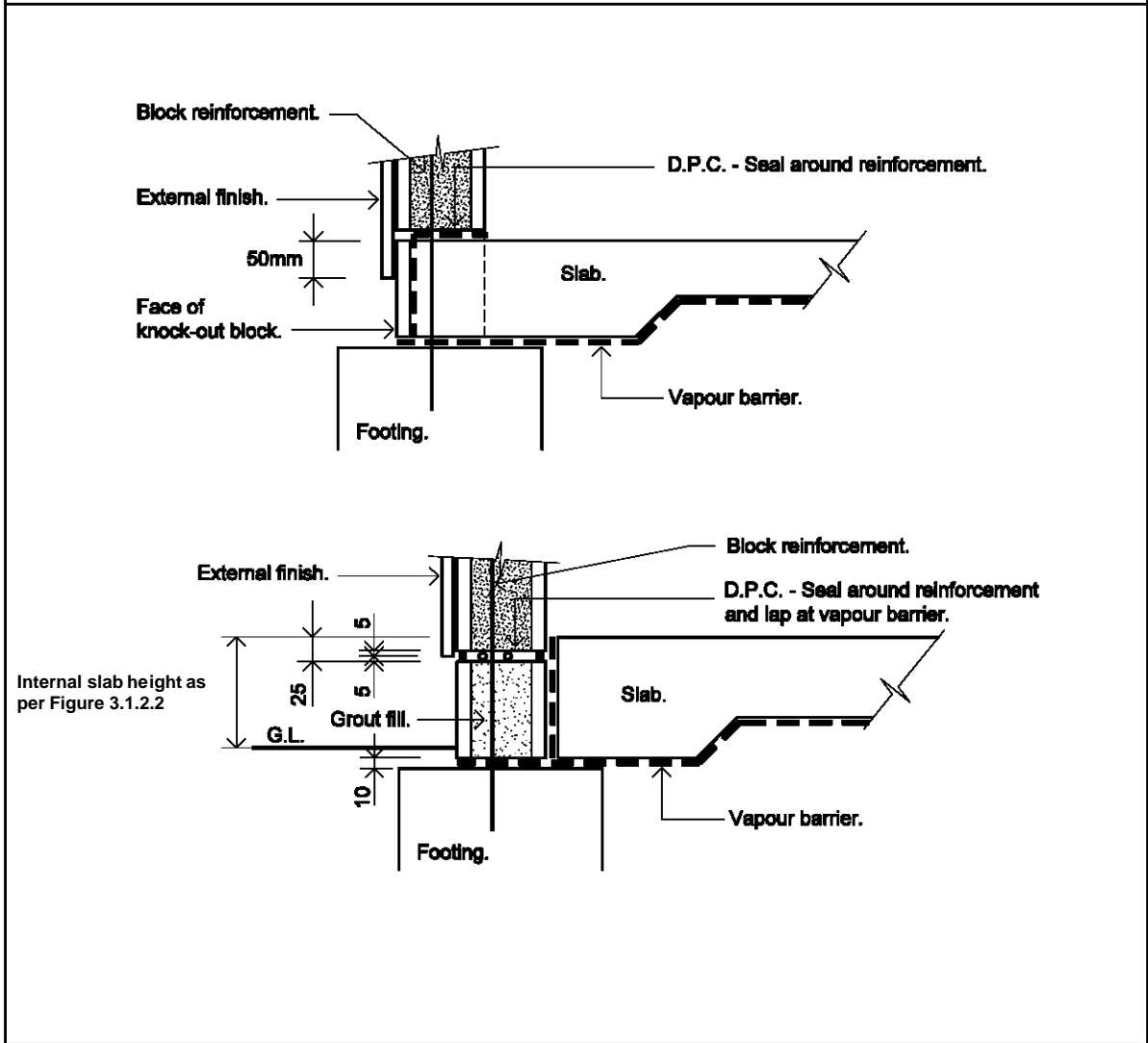

Amdt 3

PART 3.3.5 EARTH WALL CONSTRUCTION

Appropriate *Performance Requirements*:

Where an alternative earthwall building system is proposed to that described in Part 3.3.5, that proposal must comply with *Performance Requirement* P2.1 and P2.2.2 in Section 2:

Definitions

3.3.5 For the purpose of this Part:

Adobe construction means a type of construction using blocks of sun dried mud.

Bulletin 5 means CSIRO-NBTC Bulletin 5 Earthwall construction 4th Edition 1987.

Earthwall construction means *adobe construction, mechanically pressed-soil block construction or rammed-earth construction.*

Mechanically pressed-soil block construction means construction using blocks produced by pressed block making machines.

Rammed-earth construction means construction in which damp earth is tamped in situ between temporary movable formwork.

A. Acceptable construction manual

3.3.5.0 *Performance Requirement* P2.1 and P2.2.2 are satisfied for *earthwall construction* if it is designed and constructed in accordance with *Bulletin 5*.

Explanatory information:

Design requirements for other materials that may be used in combination with masonry ie heavy steel support beams etc. are described in Part 3.11 - Structural design.

B. Acceptable construction practice

3.3.5.1 Application

Compliance with this Part satisfies *Performance Requirement* P2.1 and P2.2.2 for earthwall construction, provided-

- (a) the earthwall is constructed on footings that comply with Part 3.2; and
- (b) the *design wind speed* of the area is not more than W41; and

Explanatory information:

Information on design wind speeds for particular areas may be available from the *appropriate authority*.

- (c) the *earthwall construction* does not exceed two storeys in height and walls must be laterally restrained at intermediate floor levels; and
- (d) the building is not situated on a *site* that is subject to flooding; and
- (e) for earthquake design, the building is defined as a design category H1 or H2 domestic structure in accordance with AS 1170.4.

Explanatory Information:

1. This covers all *sites* except those identified by the site investigation as having soft soil (having a soil profile with more than 5 m of soft clay, loose sand, silt or uncontrolled fill) as defined by AS 1170.4.
2. For earthquake design H3, see AS 3700 or Part 3.10.2.

3.3.5.2 General construction

A building of *earthwall construction* must be constructed in accordance with the recommendations contained in *Bulletin 5* except where varied by this Part.

3.3.5.3 Minimum thickness of walls

In a building of *earthwall construction*, the thickness of a wall must be-

- (a) in the case of *adobe construction* or *rammed-earth construction*-
 - (i) for an *external wall*, not less than 250 mm; and
 - (ii) for an internal wall, not less than 200 mm; and
- (b) In the case of *mechanically pressed-soil block construction*-
 - (i) for an *external wall*, not less than 250 mm; and
 - (ii) for an internal wall, not less than 150 mm.

3.3.5.4 Weatherproofing

Every building of *earthwall construction*-

- (a) must be provided with a suitable means of protection to prevent water from the roof running down the face of every wall; and
- (b) must, except in the case illustrated in Figure 1.3 of *Bulletin 5*, have the ground adjacent to the walls graded and paved in accordance with 1.2, 1.2.2 and 1.2.3 to prevent any surface water from reaching the walls.

Explanatory information:

Prior to and during construction, the following tests may be required by the *appropriate authority*:

- (a) In the case of-
 - (i) *rammed-earth construction* - a sample panel not less than 900 mm long by 900 mm high;
 - (ii) *adobe construction* - a sample comprising not less than 3 blocks, made of the materials and by the methods to be used in the construction, to be provided for inspection on the *site*.
- (b) In the case of *mechanically pressed-soil block construction* - tests, conducted in accordance with Appendix E of *Bulletin 5*, made on blocks of the kind to be used in the construction after they have been moist cured for seven days.

PART **3.4**

Amdt 3

FRAMING

3.4 Explanation of terms

3.4.1 Sub-floor Ventilation

3.4.2 Steel Framing

3.4.3 Timber Framing

3.4.4 Structural Steel Members

PART 3.4 CONTENTS

	Page
3.4.0 Explanation of terms	11,051
3.4.1 Sub-floor ventilation	11,101
3.4.1.1 Application	
3.4.1.2 Sub-floor ventilation	
3.4.2 Steel framing	11,301
3.4.2.0 Acceptable construction manuals	
3.4.2.1 Application	
3.4.2.2 General	
3.4.2.3 Steel floor framing	
3.4.2.4 Steel wall framing	
3.4.2.5 Steel roof framing	
3.4.2.6 Installation of services	
3.4.3 Timber framing	11,601
3.4.3.0 Acceptable construction manuals	
3.4.3.1 Application	
3.4.3.2 Materials	
3.4.3.3 Floor framing	
3.4.3.4 Flooring	
3.4.3.5 Wall framing	
3.4.3.6 Conventional roofs	
3.4.3.7 Acceptable timber frame sizes and fixing	
3.4.3.8 Bracing of timber frames	
3.4.4 Structural steel members	12,201
3.4.4 Explanation of terms	
3.4.4.0 Acceptable construction manuals	
3.4.4.1 Application	
3.4.4.2 Structural steel members	
3.4.4.3 Columns	
3.4.4.4 Corrosion protection	

PART 3.4.0 EXPLANATION OF TERMS

Explanation of terms

3.4.0.1 The following diagrams depict framing members and associated terminology used in the *Housing Provisions*.

In most cases the terminology is applicable for both steel and timber frame members.

Figure 3.4.0.1
SPAN AND SPACING TERMS

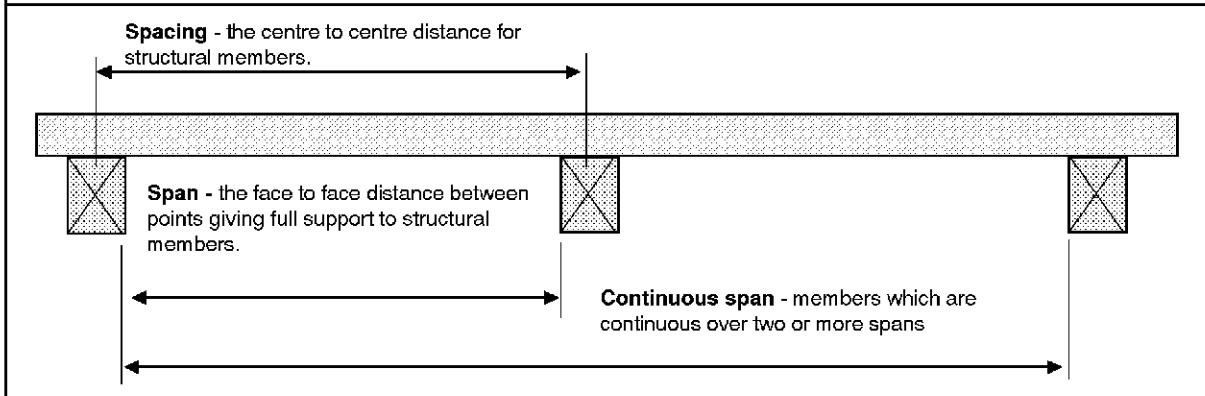
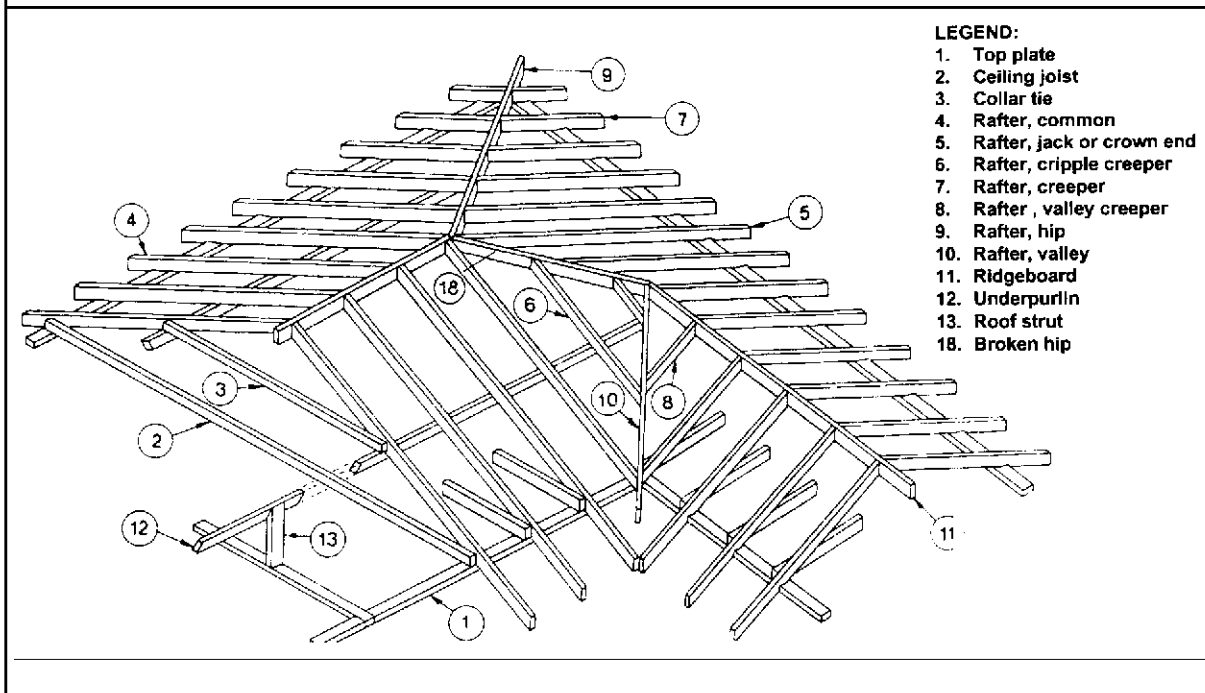
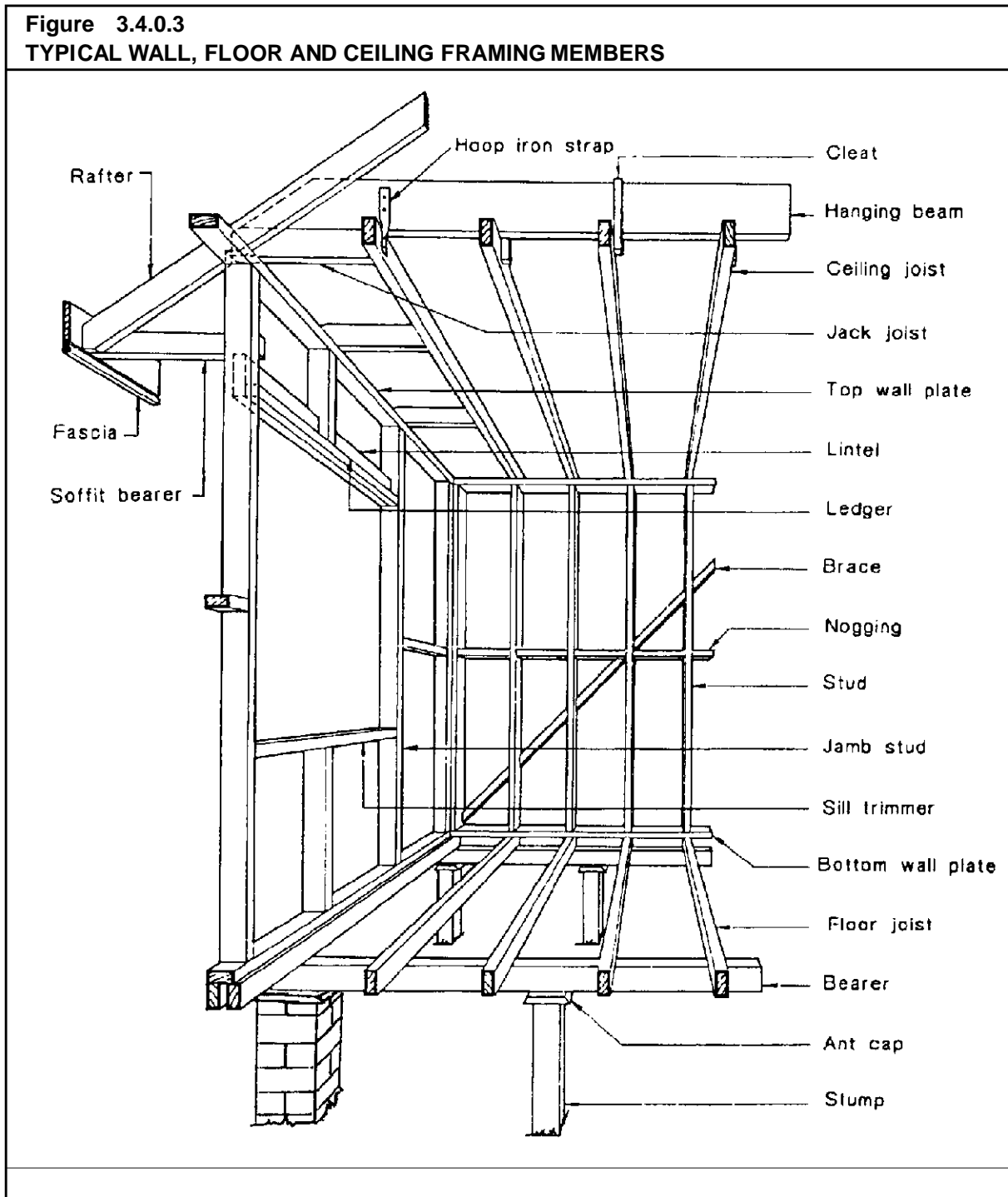

Figure 3.4.0.2
TYPICAL ROOF FRAMING MEMBERS



Amdt 3

Figure 3.4.0.3
TYPICAL WALL, FLOOR AND CEILING FRAMING MEMBERS



Amdt 3

PART 3.4.1 SUB-FLOOR VENTILATION

Appropriate *Performance Requirements*:

Where an alternative sub-floor ventilation system is proposed to that described in Part 3.4.1, that proposal must comply with *Performance Requirement P2.2.3* in Section 2.

Acceptable construction practice

3.4.1.1 Application

Compliance with this Part satisfies *Performance Requirement P2.2.3* for sub-floor ventilation.

3.4.1.2 Sub-floor ventilation

The sub-floor space beneath the suspended floor of a building must be designed and constructed in accordance with the following:

- (a) The subfloor space must-
 - (i) be cleared of all building debris and vegetation; and
 - (ii) be cross-ventilated by means of openings in the substructure walling; and
 - (iii) contain no dead air spaces; and
 - (iv) be graded in accordance with 3.1.2.3; and
 - (v) have evenly spaced ventilation openings (see Figure 3.4.1, Diagram a).
- (b) In masonry walls, the cross ventilation openings specified in (a) must be provided in both leaves of the masonry, with inner-leaf openings being aligned with outer leaf openings as precisely as possible to allow an unobstructed flow of air.
- (c) Internal walls constructed in subfloor spaces must be provided with openings-
 - (A) having an unobstructed area equivalent to that required for the adjacent external openings; and
 - (B) evenly distributed throughout such internal walls.
- (d) The clearance between the ground surface and the underside of the lowest framing member must be-
 - (i) not less than 150 mm; and
 - (ii) in accordance with the requirements, if any, for the flooring material used; and

- (iii) as *required* for inspection of termite barriers installed in accordance with AS 3660.1 (see Figure 3.4.1, Diagram b).
- (e) Internal and *external wall* vents to be provided at a rate of not less than 7300 mm²/m length of wall.
- (f) Where *external walls* abut other construction or ventilation is obstructed by patios, paving or the like, additional ventilation must be provided to ensure that the overall level of ventilation is maintained.
- (g) Where the ground or sub-floor space is excessively damp-
 - (i) increase the level of sub-floor ventilation; or
 - (ii) provide a sealed impervious membrane over the ground and ensure ponding of water does not occur by grading the ground in accordance with 3.1.2.3.

Figure 3.4.1

TYPICAL SUB-FLOOR VENTILATION DETAILS

Diagram a. Typical Cross Ventilation Of Sub-Floor Area

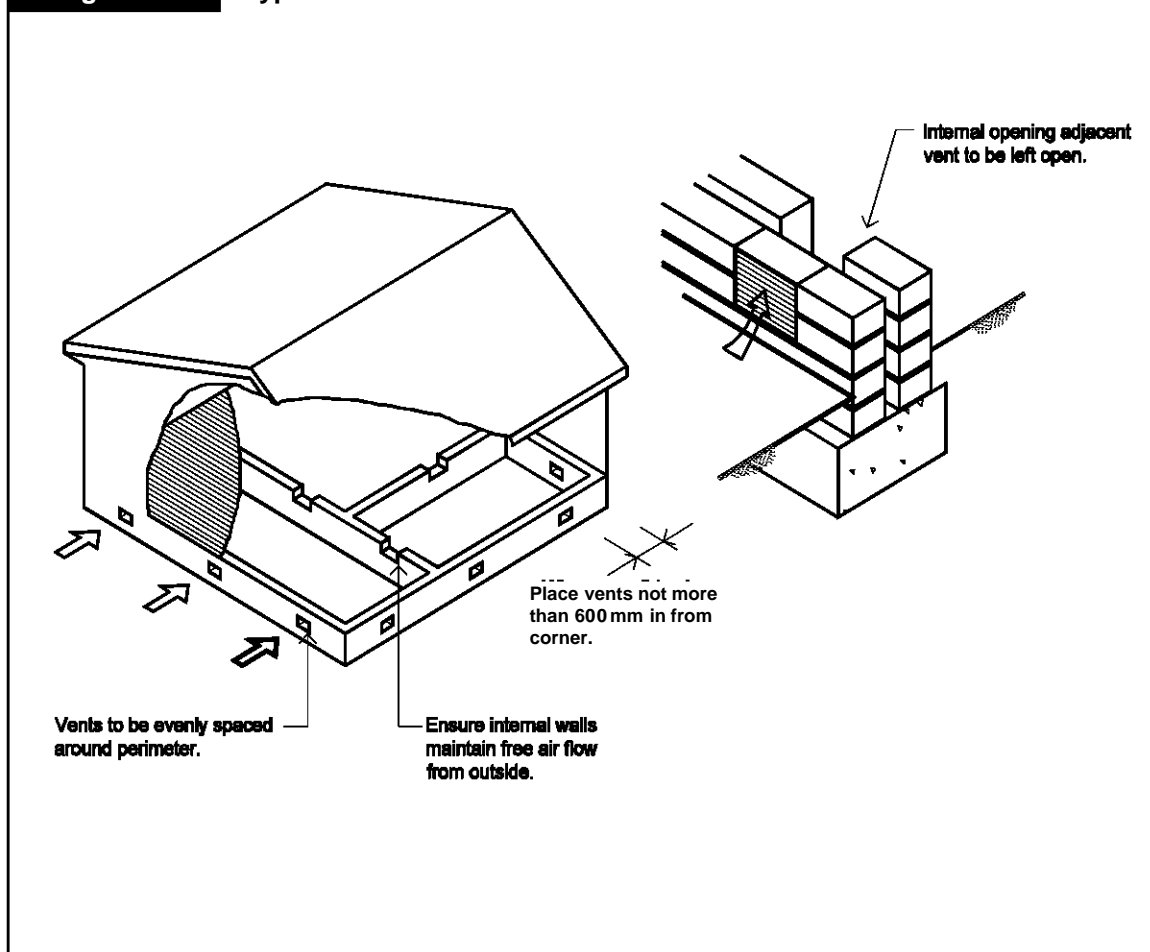
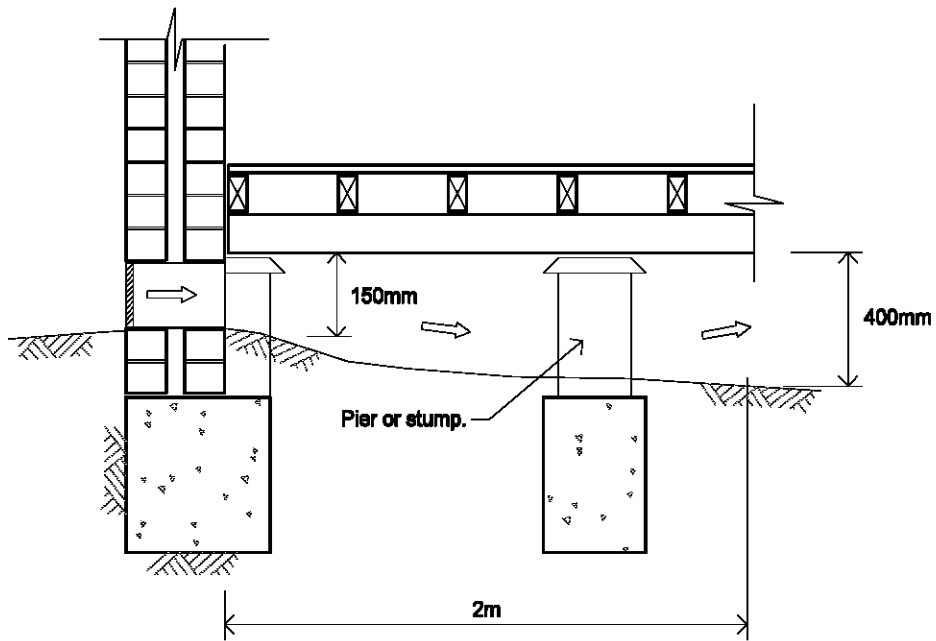

Figure 3.4.1
TYPICAL SUB-FLOOR VENTILATION DETAILS

Note: 400 mm clearance required only where termite barriers are installed that need to be inspected (see Part 3.1.3).

Diagram b. Sub-Floor Clearance Requirements



Amdt 3

PART 3.4.2 STEEL FRAMING

Appropriate *Performance Requirements*:

Where an alternative steel framing system is proposed to that described in Part 3.4.2, that proposal must comply with *Performance Requirement P2.1* in Section 2.

A. Acceptable construction manuals

3.4.2.0 Performance Requirement P2.1 is satisfied for cold formed steel framing if it is designed and constructed in accordance with one of the following manuals:

- (a) AS 1250 - The use of steel in structures.
- (b) AS 3623 - Domestic metal framing.
- (c) AS 4100 - Steel structures.

Explanatory information:

Design requirements for other materials used in combination with steel framing, including the use of concrete floors, heavy steel support beams etc. are described in Part 3.11 - Structural design; or Part 3.4.4 for structural steel members.

B. Acceptable construction practice

3.4.2.1 Application

Compliance with this Part satisfies *Performance Requirement P2.1* for steel framing, provided-

- (a) the frame is cold-formed metal framing designed and constructed in accordance with AS 3623 or AS/NZS 4600; and
- (b) the frame material has a yield stress of not less than 250 MPa.

3.4.2.2 General

3.4.2.2
Amdt No. 3

- (a) The steel frame must be protected from corrosion in accordance with the following:
 - (i) Where the steel frame is within the building envelope, in locations-
 - (A) more than 300 m from breaking surf, or
 - (B) not in a heavy industrial area; or
 - (ii) where the steel frame is outside the building envelope – in locations-
 - (A) more than 1 km from salt water which is not subject to breaking surf, such as a lake or protected bay; or

- (B) more than 10 km from a coastal area with breaking surf; or
- (C) not in a heavy industrial area,

the steel frame must have a minimum coating class in accordance with AS 1397 of Z275 (275 grams of zinc per square metre) or AZ150 (150 grams of aluminium/zinc per square metre).

- (iii) In areas not specified in (i) or (ii), a higher level of corrosion protection is *required*.

- (b) The frame must be permanently electrically earthed on completion of fixing.

Expl. Info.
Amdt No. 3

Explanatory information:

The steel frame requirements of this Part should be considered in conjunction with steel frame design and construction advice from the manufacturer.

For the purpose of 3.4.2.2, the building envelope is deemed to be a space in the building where the steel frame does not have direct contact with the external atmosphere, other than for normal ventilation purposes. Examples of such locations are frames which are clad or lined on both sides or frames in masonry veneer construction. Areas not within the building envelope include floor framing members where there is no continuous perimeter sub-floor walling or verandah roof framing members with no ceiling lining.

Cut edges on framing components do not constitute a corrosion problem, as the surface area of the metallic coating on either side of the cut edge is far greater than the surface area of the cut edge itself.

Where hole cutting or cutting of members is required, cutting methods that clearly shear or leave clean edges are preferred over those that leave burred edges or swarf.

The adoption of appropriate brick cleaning measures will ensure no damage of any metal or metallic coated components, this would include the shielding of these components during the acid cleaning process. Channels to steel framing should be cleaned of mortar droppings.

Metallic coated steel should not come into contact with green wood containing acidic material or CCA treated timbers unless an impervious non-conductive material is located between the dissimilar elements. The use of kiln or appropriately dried timbers is recommended where contact between the metallic coated steel component and timber is considered.

3.4.2.3 Steel floor framing

The following provisions apply to suspended steel floor framing for single-storey and both floors of two-storey construction:

- (a) The two types of suspended floor systems referred to in 3.4.2.3 are-
 - (i) in-plane systems, such as joist-only systems or systems with integral bearers; and
 - (ii) conventional joist-over-bearer systems (see Tables 3.4.2.1 and 3.4.2.2 for acceptable sizes and spacings).
- (b) When used in ground floor construction, all such systems must be installed on stumps, piers or masonry footings complying with Part 3.2. Conventional flooring can be installed on top of the floor frame.

- (c) Fibre cement packers or similarly durable and compatible materials may be used when packing is necessary under suspended flooring systems and must be at least the width of the member to ensure adequate bearing capacity.

Table 3.4.2.1 SPANS FOR C-SECTION FLOOR JOISTS			
SPAN	SECTION	Maximum Joist spacing (mm)	
		450	600
		Maximum span (mm)	
Single span	C15012	2.7	2.7
	C15015	3.3	3.0
	C15019	3.6	3.3
	C20015	4.5	3.9
	C20019	4.8	4.2
	C20024	5.1	4.5
Continuous span	C15012	4.2	3.0
	C15015	4.5	4.2
	C15019	4.8	4.5
	C20015	5.4	4.8
	C20019	5.7	5.4
	C20024	6.0	5.7

Explanatory information:

The size of C-section steel members are identifiable by their description. For example, a C15012 is 150 mm deep and is made from 1.2 mm thick steel.

**Table 3.4.2.2
Amdt No. 2**

Table 3.4.2.2 SPANS FOR C-SECTION BEARERS										
Steel Section	SINGLE SPAN					CONTINUOUS SPAN				
	Effective Bearer Spacing (m)					Effective Bearer Spacing (m)				
	1.8	2.4	3.0	3.6	4.2	1.8	2.4	3.0	3.6	4.2
	MAXIMUM SPAN OF BEARER (m)					MAXIMUM SPAN OF BEARER (m)				
C15015	2.2	2.1	1.9	1.8	1.7	2.7	2.5	2.4	2.3	2.1
C15019	2.4	2.2	2.0	1.9	1.8	2.9	2.7	2.5	2.4	2.2
C20015	2.9	2.7	2.4	2.1	1.8	3.4	2.7	2.4	2.1	1.8
C20019	3.1	2.9	2.7	2.5	2.4	3.8	3.5	3.3	3.2	3.0
C25019	3.6	3.4	3.2	3.0	2.6	4.6	3.8	3.4	3.0	2.6
C25024	3.9	3.7	3.4	3.3	3.0	4.8	4.6	4.2	4.1	3.8

Note: For the purposes of this Table:
 (a) Loads must be evenly distributed along the member.
 (b) Sections must be stiffened at end supports.

Amdt 3

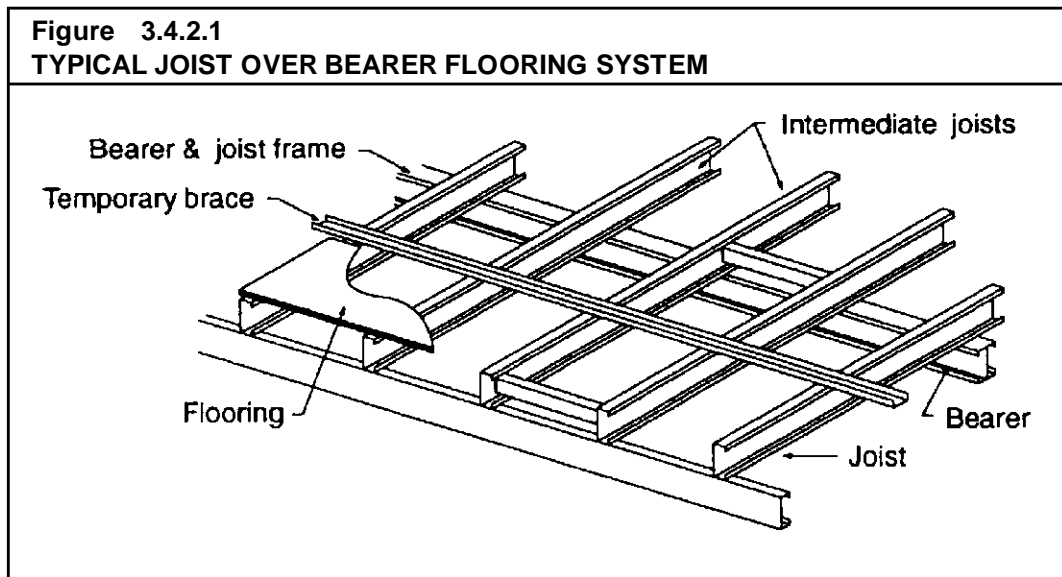

3.4.2.4 Steel wall framing

Steel wall framing must be constructed in accordance with Figures 3.4.2.2 to 3.4.2.4 and the following requirements:

- (a) Bracing
 - (i) The wall frame must-
 - (A) have bracing designed in accordance with AS 3623; and
 - (B) be braced so that wind forces both during and after the erection of the frame are taken into account.
 - (ii) Wall frame bracing may be either-
 - (A) in-plane bracing as shown in Figure 3.4.2.3; or
 - (B) steel strap bracing as shown in Figure 3.4.2.3; or
 - (C) sheet bracing as shown in Figure 3.4.3.20.

Figure 3.4.2.2
TYPICAL WALL FRAMING AND SECTION MEMBERS

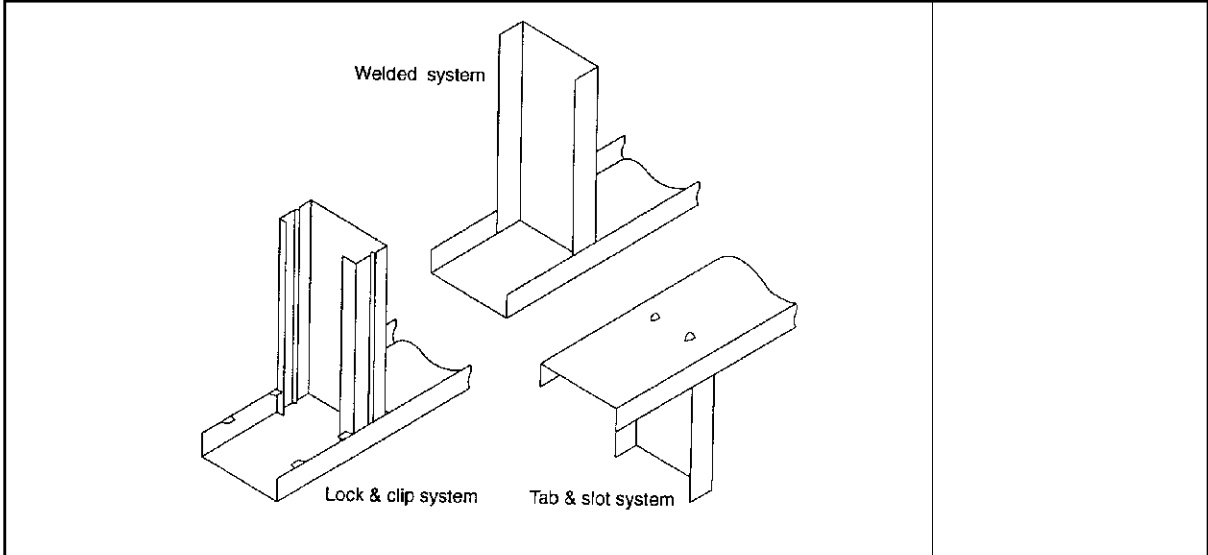
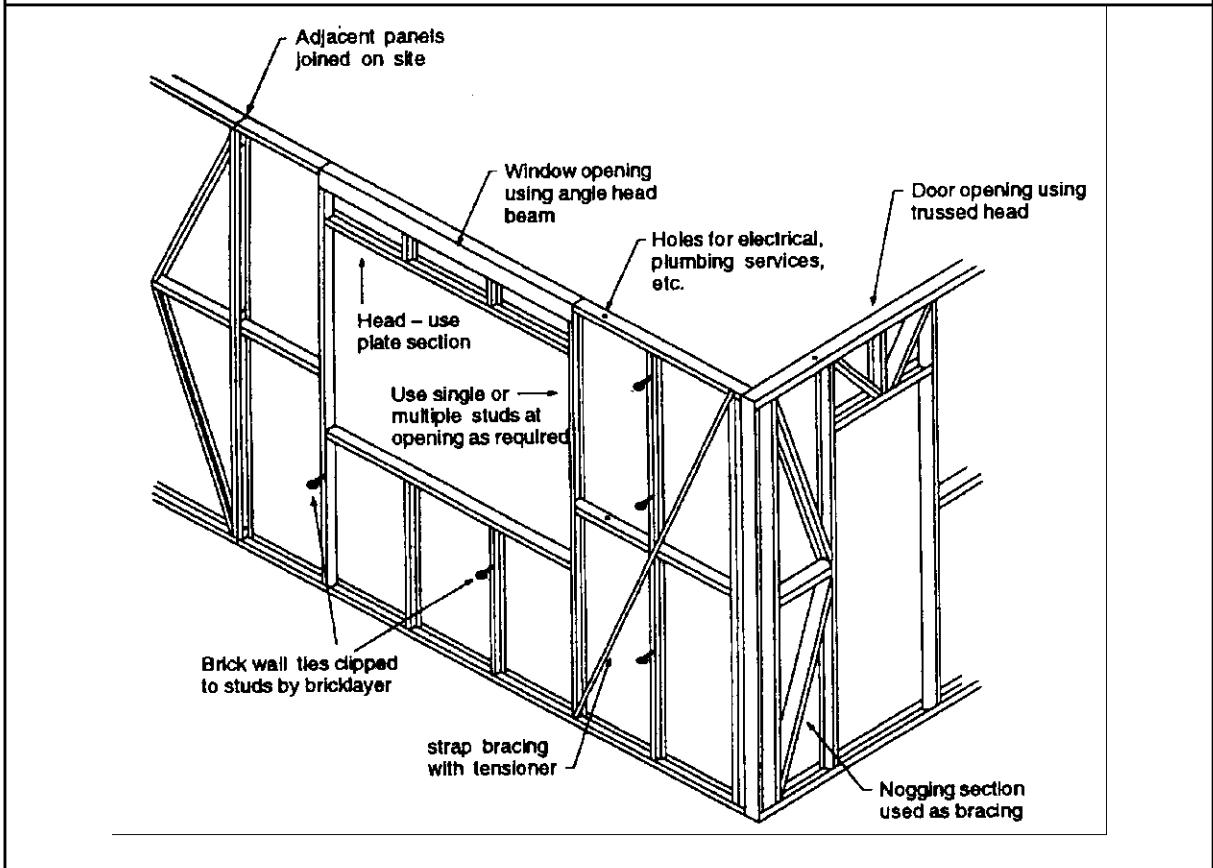

Figure 3.4.2.3
TYPICAL BRACING SYSTEM DETAILS



Amdt 3

Explanatory information:

Steel frame bracing:

Frames are either in rigid or adjustable form. In the case of rigid frames, minor irregularities in flooring are accommodated by packing.

With adjustable frames, the tensioner assembly on the bracing can usually be adjusted to accommodate these irregularities. After tensioning, bracing straps must be securely fixed to each stud and nogging (see Figure 3.4.2.3).

Long runs of external walling may have to be temporarily braced, until the roof members have been fixed. This can be carried out by using lengths of steel, timber or roof battens fixed to the top of the studs and secured to the ground or floor, as temporary props.

Further construction stage bracing may be required to be installed before roof cladding commences. This is required to prevent side sway of the building during construction.

Construction bracing should be provided in the following minimum percentage of required vertical bracing:

- 40% single storey slab-on-ground buildings;
- 40% upper storey of buildings with suspended floors;
- 50% lower storey of 2 storey construction.

- (b) Hold-down of the wall to the footing system must be as follows:
 - (i) Common studs must be connected to the slab or other alternative flooring system in accordance with Figure 3.4.2.4 - Diagram a.
 - (ii) Walls in areas with a *design wind speed* of more than W41 must be connected to the slab in accordance with Figure 3.4.2.4 - Diagram b.
- (c) Fixings for hold down of wall framing must be as close as practical to a stud and located-
 - (i) at the ends of each wall panel; and
 - (ii) at each side of openings up to 2.4 m in width and two fixings at each side for openings more than 2.4 m in width; and
 - (iii) at each stud near ends of bracing; and
 - (iv) at not more than 1.2 m centres.

Figure 3.4.2.4
TYPICAL WALL FRAME HOLD DOWN CONNECTIONS

Note: Fasteners must be installed in locations that achieve maximum grip while avoiding spalling the edge of the concrete slab.

Diagram a. For Areas With A Design Wind Speed Of Not More Than W41

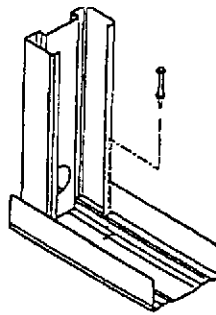

Concrete slab - Tiled roof
Powder actuated fasteners

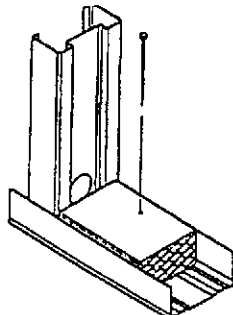

Concrete slab - Tiled roof
75 mm hand driven concrete
nail through timber block

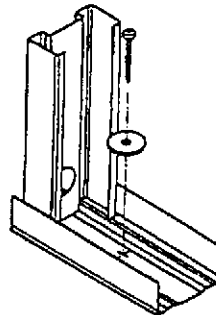

Concrete slab - Sheet roof
Masonry anchor with washer

Diagram b. For Areas With A Design Wind Speed Of More Than W41

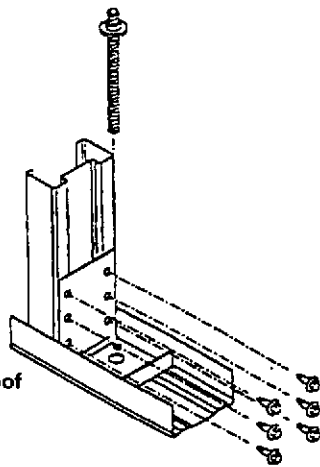

Concrete slab - Sheet roof
Chemical anchor with
bracket and washer

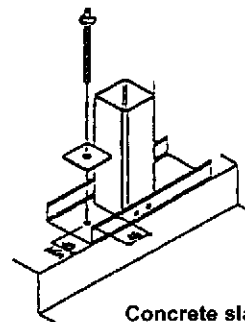

Concrete slab - Sheet roof
Chemical anchor with
washer

- (d) Packers used under the bottom plate to level frames must be-
 - (i) located under each affected stud; and
 - (ii) not less than the width of the plate; and
 - (iii) fibre cement or other similarly durable and compatible material.

Amdt 3

3.4.2.5 Steel roof framing

Steel roofing systems may be of trussed construction, pitched or a combination of both and must be constructed in accordance with the following:

- (a) Battens - steel or timber battens for roof cladding must be fixed by screwing, suitable nailing or clipping.
- (b) Fascias and eaves - steel roof systems can include either steel or timber fascias and the eaves construction can be either boxed or raked.
- (c) Bracing for roofs must be in accordance with AS 3623 and fixed as shown in Figures 3.4.2.5 and 3.4.2.6.

Amdt 3

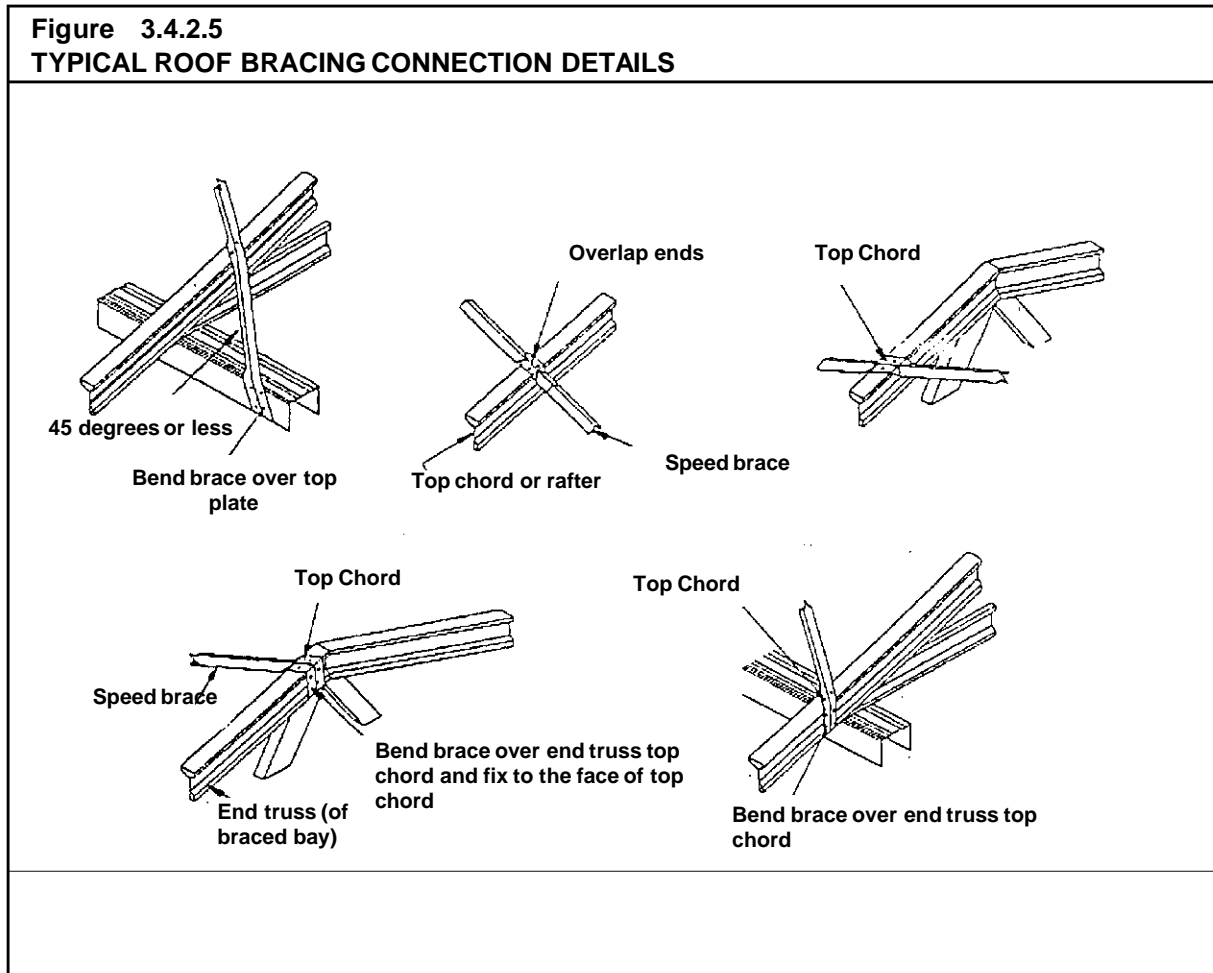

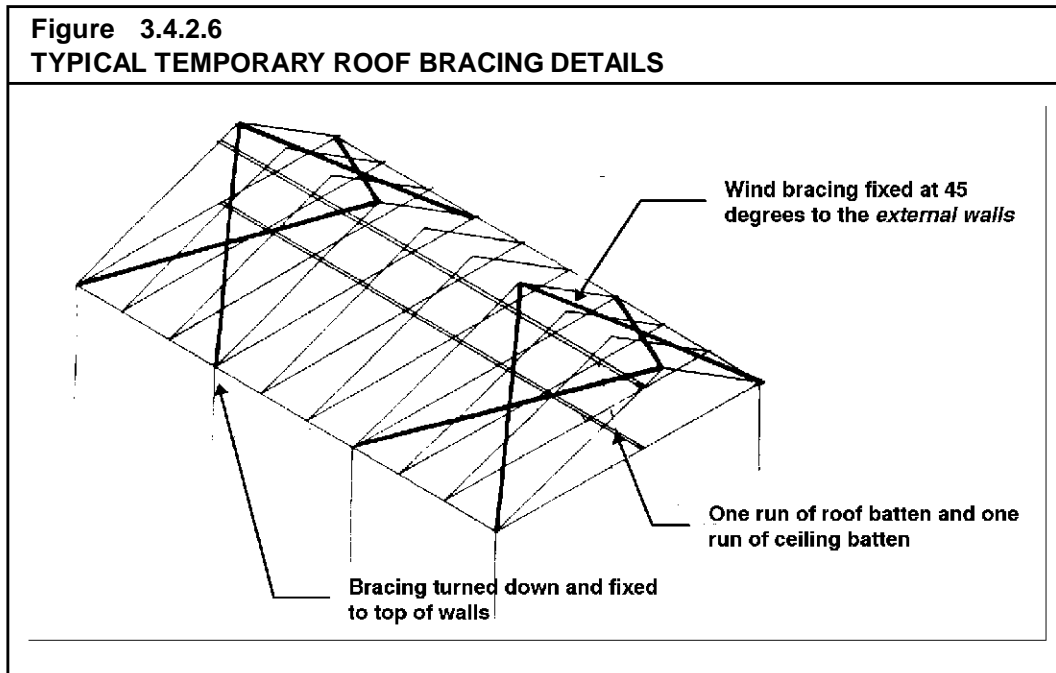
**Explanatory information:**

Trusses and rafters are fixed in accordance with the design details. Generally, the roof members are fixed to the wall structure using conventional building methods.

Fixings

The fixings may incorporate nails, self-drilling screws, bolts and nuts or shear plate connectors. The fixings should be adequate to ensure that a continuous load path exists from the roof to the foundations for all types of loading including uplift, downward and shear loading.

Temporary roof bracing

Temporary roof bracing is generally achieved using one run of roof battens along the full length of the house. It is preferable if the run nearest the roof apex is used for this purpose and fixed as each truss is properly positioned. Next, one run of ceiling battens should be positioned and fitted. This should preferably be the batten run nearest the centre of the building.

Where ceiling battens are not used a bottom chord tie should be installed in accordance with the design details.

Wind bracing

Wind bracing should be attached when all trusses have been erected and fixed. Generally all gable roofs and long hipped roofs require bracing in the roof plane. The strap bracing is installed similar to wall bracing and runs from the apex of the roof to the external wall, over the top of at least three trusses or rafters, at approximately 45° to the *external walls*. The bracing is fixed at the ends, tensioned and fixed to each intermediate truss or rafter.

3.4.2.6 Installation of services

To maintain the structural integrity of the frame, all ancillary work must be in accordance with the following:

- (a) Service penetrations in floor joists must comply with Figure 3.4.2.8.
- (b) Plumbing pipe-work in steel framed construction must be run in the following ways:
 - (i) Pipe-work must be-
 - (A) run through pre-punched service holes in steel studs; and
 - (B) extra holes, where necessary, must be located near the centre-line of each stud provided-
 - (aa) the structural integrity of the member is not reduced; and
 - (bb) the hole is not more than 10% larger than the existing holes.
 - (ii) In masonry veneer construction, pipe runs may be located in the *cavity* and fixed to the studs with full pipe saddles and self drilling screws properly protected against galvanic corrosion in accordance with (v).
 - (iii) In construction where external cladding is attached directly to the steel stud work, piping can be-
 - (A) installed over the ceiling; or
 - (B) suspended under the floor; or
 - (C) installed in accordance with (i).
 - (iv) Plumbing fittings may be attached by-
 - (A) timber or steel noggings fitted between studs to support tap sets, baths and sinks; and
 - (B) where a steel nogging is used, the tap set must be isolated to prevent corrosion by a durable non corrosive material such as timber, cement sheet etc (see Figure 3.4.2.7).
 - (v) Copper and brass pipes and fittings must be prevented from coming into contact with the steel frame by one of the following methods:
 - (A) Where plumbing services pass through service holes, plastic grommets must be snapped into the service hole.

Explanatory Information:
The use of grommets also has the effect of securely fixing the pipe to prevent water hammer.

 - (B) In other areas where copper pipes may come into contact with metal framing, they must be lagged or isolated with neoprene sheeting or tape.
- (c) Electrical cables must be-

- (i) run through pre-punched service holes in steel studs (See Figure. 3.4.2.7); or
- (ii) secured to steel framing with-
 - (A) P clips; or
 - (B) plastic ratchet straps; or
 - (C) half saddles fixed with screws or rivets; and
- (iii) extra holes, where necessary, must comply with (b)(i)(B); and
- (iv) steel frames must be permanently earthed immediately after the frame is erected; and
- (v) Backing plates for switches and power points must be fixed at the appropriate positions with suitable fasteners. Where it is impractical to fix directly onto studwork, steel or timber nogginns can be fitted between the studs to provide necessary fixing and support.

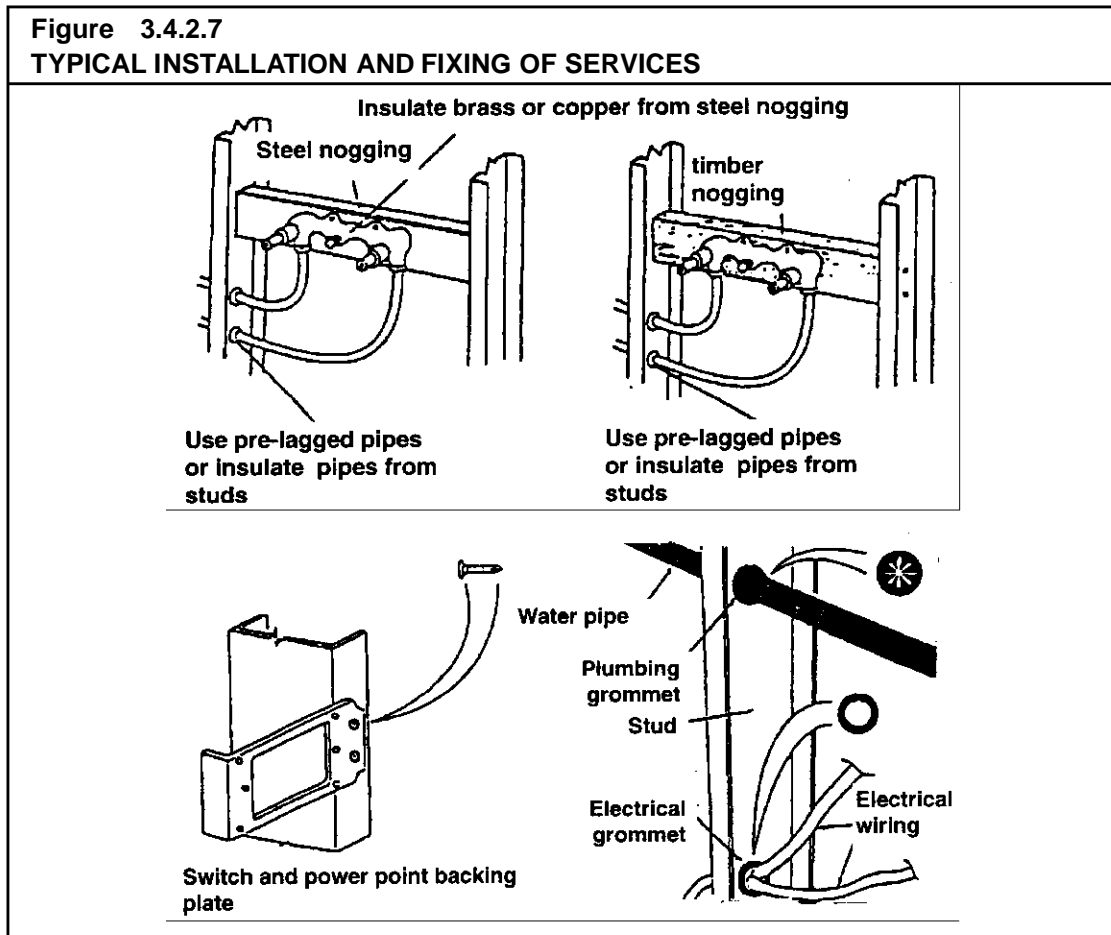

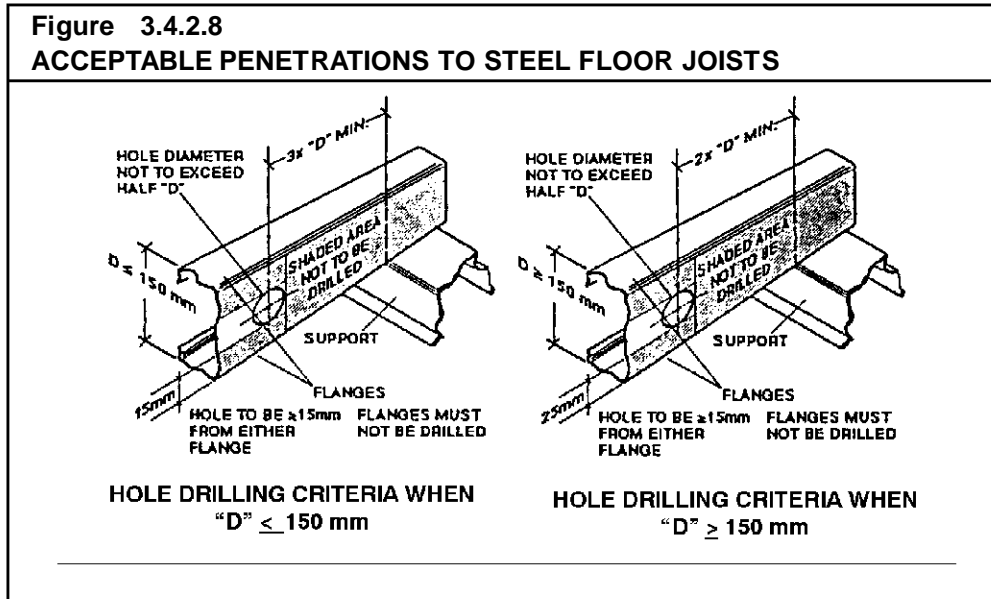

Amdt 3

Explanatory Information: Connections for steel framing

The following fasteners and connections are acceptable for the assembly and erection of steel framed houses:

Bolts: Bolted connections are used as a means of on-site jointing, particularly where joints are highly loaded and offer a consistent design strength. Bolt design for cold-formed sections is adequately covered in the Australian Standards.

Rivets: Riveted connections (either pre-drilled or self-piercing) are used for both factory and on-site fabrication and have also been used as elements of proprietary joining systems.

Screw: Self-drilling screws are widely used as a means of connection in almost every aspect of on-site work during the erection of steel framed houses. They are used for connecting wall frame modules, through to attachment of claddings and internal linings.

Adhesives: Adhesives are used in steel framing for attachment of internal linings, including flooring. They are generally used in combination with mechanical fasteners such as self-drilling screws. The screws are primarily used to fasten the linings while the adhesives set, although they continue to act as part of a composite fastening system.

Clinches: Clinching involves the connection of two thicknesses of sheet steel by extruding one sheet into the other using a punch and die, in such a way that the two pieces cannot be subsequently separated. A typical clinched joint used in factory fabrication is usually hydraulically activated whereas clinching systems used on site are typically pneumatic or electrically driven.

Welds: Welding (typically Mig) has been the most common form of connection during factory assembly for many years. The welded joint strength can vary and the metallic coating is affected in the weld area, the affected area will require post-painting (cold galvanising).

Nails: Hard steel twist nails are used in steel framing for both factory and on site fabrication. These nails can be used in materials up to 2 mm thick. Nails have also been used for the connection of wall plates to concrete slabs. Where this is done by hand, a timber starter block is normally used. More recently, power actuated nails have been used.

PART 3.4.3 TIMBER FRAMING

Appropriate *Performance Requirements*:

Where an alternative timber framing design is proposed to that described in Part 3.4.3, that proposal must comply with *Performance Requirement P2.1* in Section 2.

A. Acceptable construction manuals

3.4.3.0 *Performance Requirement P2.1* is satisfied for a timber frame if it is designed and constructed in accordance with one of the following manuals:

- (a) AS 1684 - National timber framing code.
- (b) Timber framing manual - (Timber Promotion Council).
- (c) Timber framing manual - Supplementary Tables - (Timber Promotion Council).
- (d) Timber framing manual W33N-W41N - (Timber Research and Development Advisory Council - Queensland).
- (e) NSW Timber framing manual - (State Forests of NSW).
- (f) In a Class 10a building with a *floor area* less than 60 m² not located in an *alpine area*, and where the *design wind speed* does not exceed W33: CSIRO-DBC&E Special Report- Low Rise Domestic and Similar Framed Structures, Part 4-Supplementary Domestic Buildings for Built-up Areas, Sections I to V.

Expl. info.
Amdt No. 2

Explanatory information:

1. Design requirements for other materials used in combination with timber framing, including the use of concrete floors, heavy steel support beams etc. are described in Part 3.11 - Structural design; or Part 3.4.4 - Structural steel members.
2. For additional construction requirements in *high wind areas* (ie >W41), see Part 3.10.1.
3. Unless otherwise noted, the acceptable construction practice contained in this Part is only suitable for single storey construction.

B. Acceptable construction practice

3.4.3.1 Application

Compliance with this Part satisfies *Performance Requirement P2.1* for timber framing, provided-

- (a) the building is single storey; and

- (b) the building is located in an area with a *design wind speed* of not more than W41; and

Explanatory Information:

1. Information on *design wind speeds* for particular areas may be available from the *appropriate authority*.
2. A map indicating cyclonic regions of Australia is contained in Part 3.10.1.

- (c) the size and fixing of the timber members must be in accordance with the appropriate requirements described in 3.4.3.7; and
- (d) the frame is braced in accordance with the appropriate requirements described in 3.4.3.8; and
- (e) for earthquake design, the building is defined as a design category H1 or H2 domestic structure in accordance with AS 1170.4; and

Explanatory Information:

This covers all *sites* except those identified by the site investigation as having soft soil (having a soil profile with more than 5 m of soft clay, loose sand, silt or uncontrolled fill) as defined by AS 1170.4.

- (f) the building is not constructed in an *alpine area*; and
- (g) the frame is constructed on footings that comply with Part 3.2; and
- (h) the building has a geometry and envelope that does not exceed the limits given in Figure 3.4.3.0 and-
- (i) the rafter or truss spacing is not more than 600 mm for tile roofing and 900 mm for sheet roofing; and
 - (ii) the stud spacing is not more than 600 mm; and
 - (iii) the floor joist spacing is not more than 600 mm; and
 - (iv) the bearer spacing and span is not more than 1.8 m; and
- (i) the building otherwise complies with AS 1684.

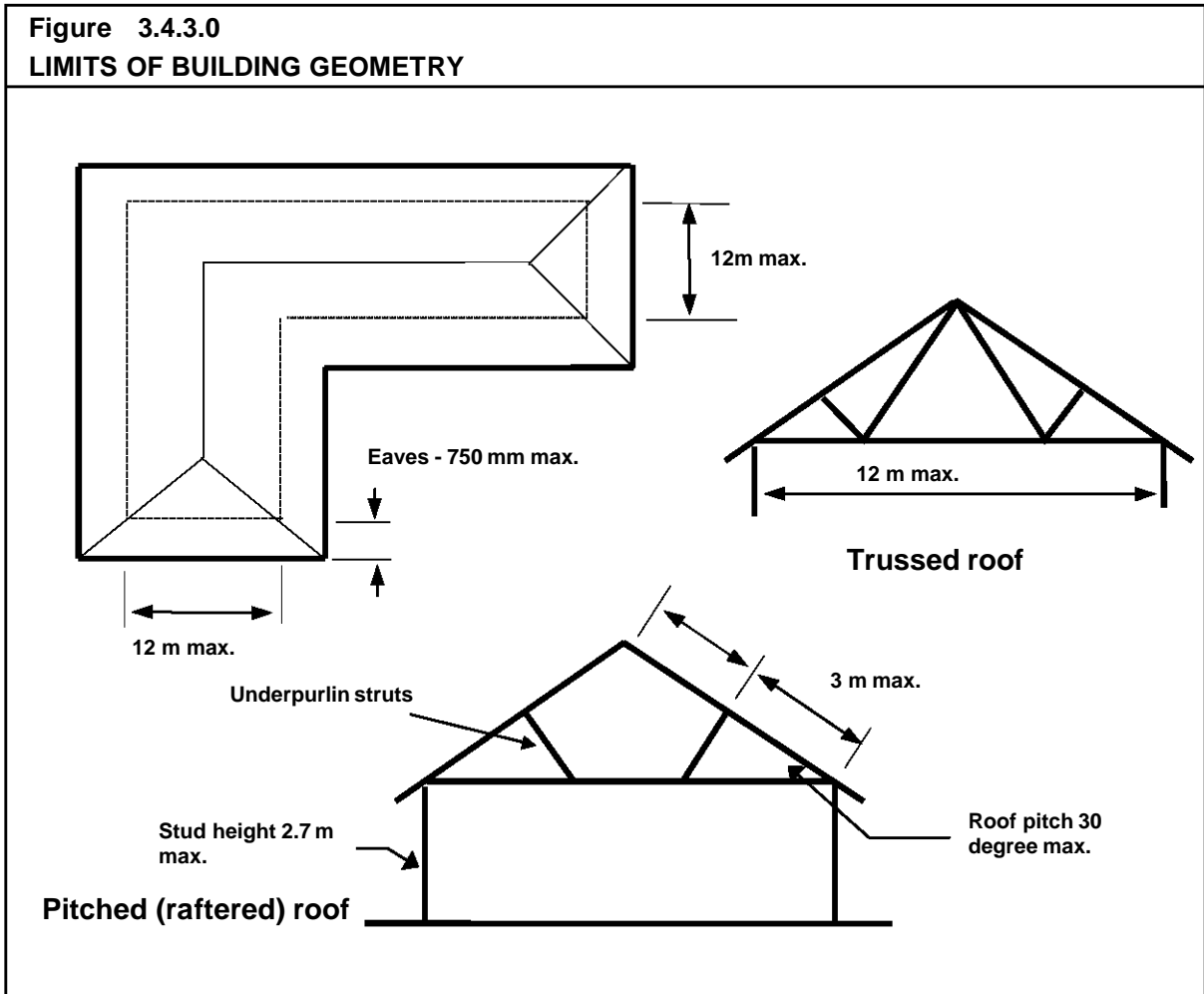

Amdt 3

3.4.3.2 Materials

(a) Standards and Grades

- (i) All timber used for structural purposes must be stress-graded in accordance with relevant Australian Standards and have the stress grade identified.
- (ii) Where colours are used to indicate the stress grade, the following applies:

F4 - Red	F11 - Purple
F5 - Black	F14 - Orange
F7 - Blue	F17 - Yellow
F8 - Green	F22 - White
- (iii) A higher stress grade can be used instead of the specified stress grade.

- (b) All metal brackets, fixing plates and other associated fixings used in structural timber joints and bracing must have appropriate corrosion protection-
 - (i) in accordance with AS 1684; and
 - (ii) for self drilling screws, in accordance with AS 3566.

STATE AND TERRITORY VARIATIONS

In Queensland after 3.4.3.2(b) insert Qld 3.4.3.2(c) as follows:

Qld 3.4.3.2(c) Timber Species

- (c) Timber Species
Timber used for structural purposes must be a species scheduled for the appropriate use in Schedules A, B or C in Queensland Forest Service of the Department of Primary Industries Technical Pamphlet No. 1 - Building Timbers, Properties and Recommendations for their Use in Queensland.

3.4.3.3 Floor Framing

Timber floor framing must be constructed in accordance with the following requirements:

- (a) Drilling and notching of bearers and joists must not exceed that shown in Figure 3.4.3.1.
- (b) Bearers and joists must be located directly under all external and internal *loadbearing* walls in accordance with Figure 3.4.3.2.

Figure 3.4.3.1
DRILLING AND NOTCHING OF BEARERS AND JOISTS

Notes:

- (1) Notches in both surfaces at the end of any member are not permitted.
- (2) Minor excesses in depth may be levelled by checking up to 6 mm over supports.

Diagram a. Drilling

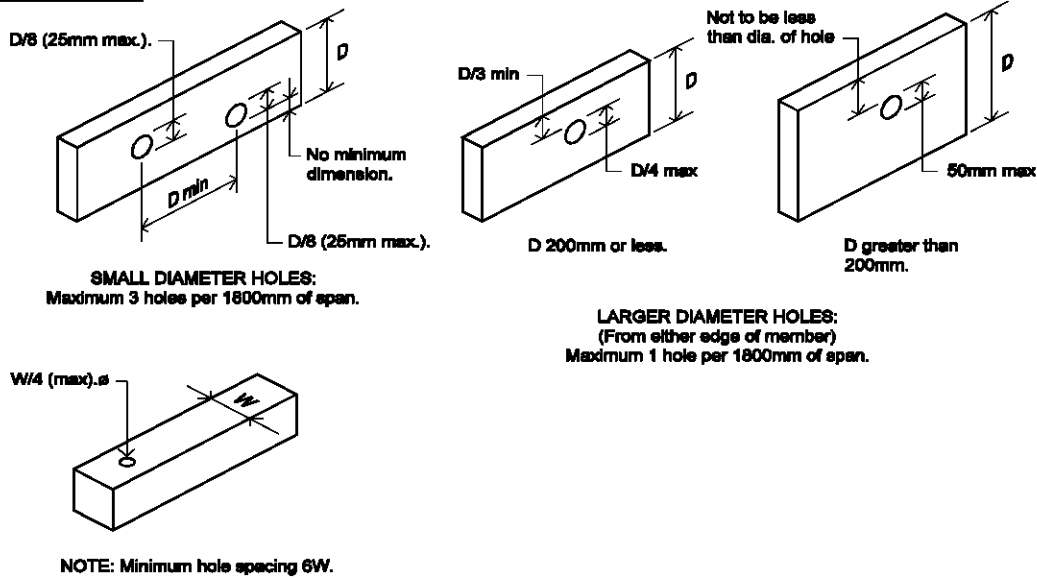
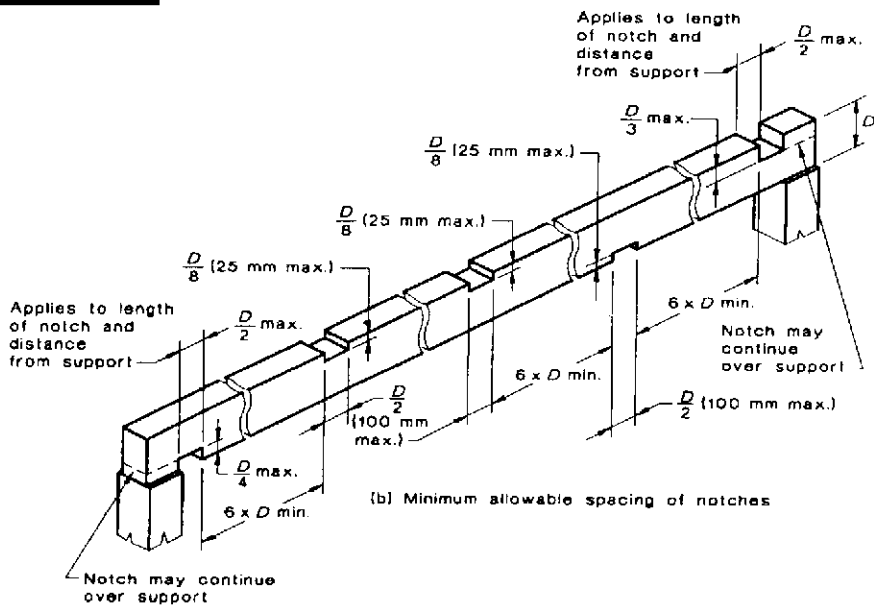
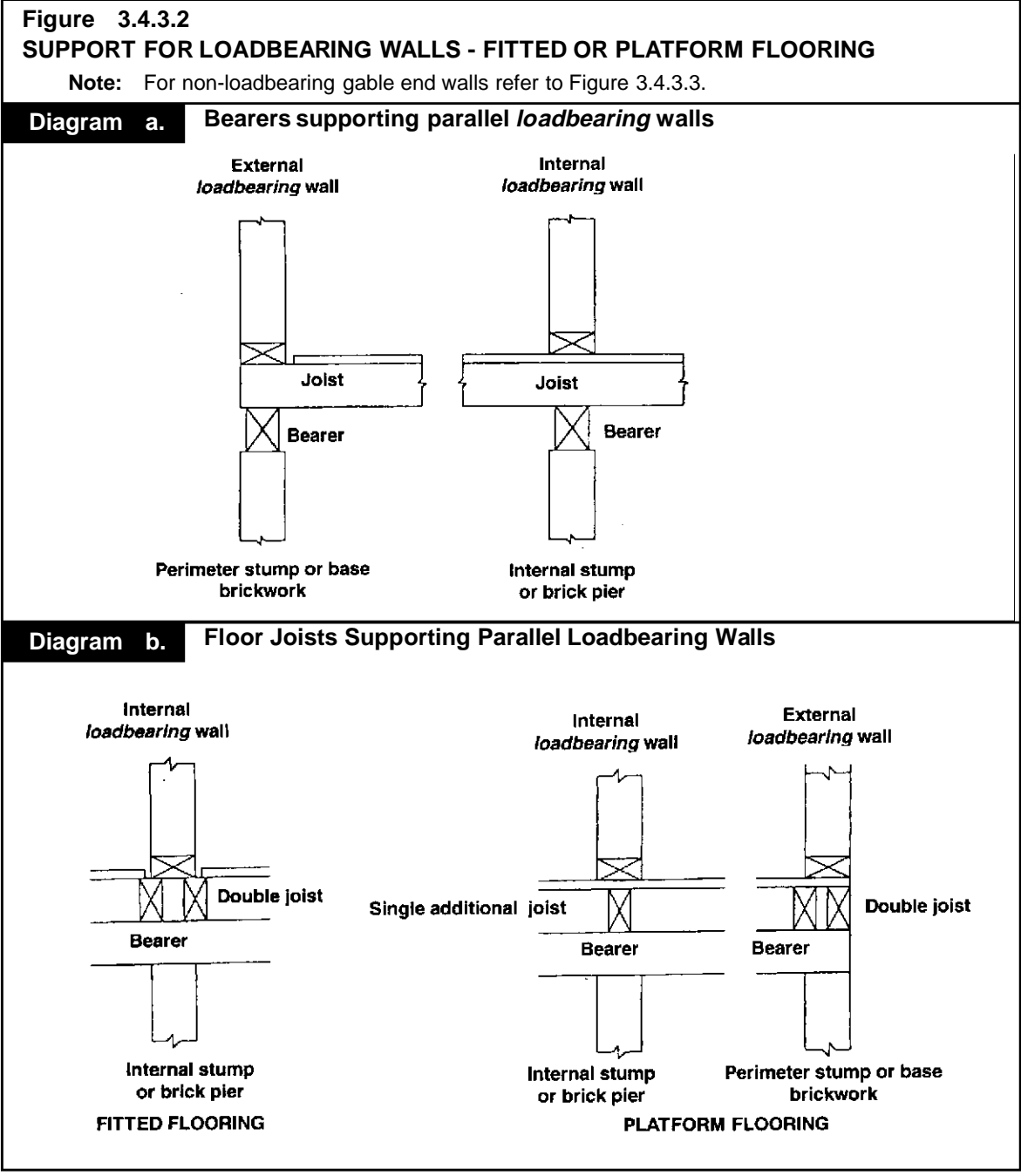

Diagram b. Notching



Amdt 3



Amdt 3

(c) Bearers and joists supporting non-loadbearing walls (including gable-end walls) must be located in accordance with Figure 3.4.3.3.

**Figure 3.4.3.3
SUPPORT FOR NON - LOADBEARING WALLS**

Note: Bearers and joists are considered as supporting floor loads only.

Diagram a. Internal Non-loadbearing Walls

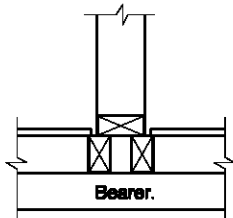

Double joists required to support flooring.
FITTED FLOOR.

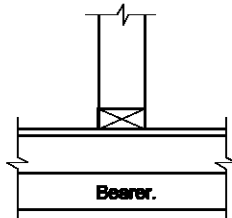

No location requirements for joists.
PLATFORM FLOOR.

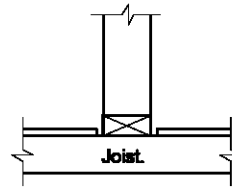

No location requirements for bearers.
FITTED OR PLATFORM FLOOR.
(Fitted shown).

Diagram b. External Non-loadbearing Walls

Note: External non-loadbearing walls must not support roof loads (eg. gable end wall in truss roof construction). However, ceiling loads may be supported.

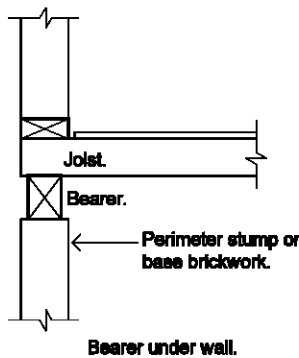

Bearer under wall.
FITTED OR PLATFORM FLOOR.
(Fitted shown).

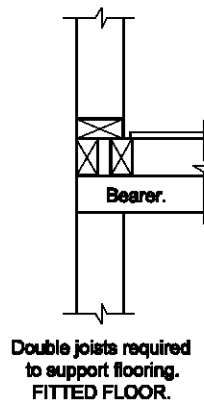

Double joists required to support flooring.
FITTED FLOOR.

- (d) Where the depth of floor joists is equal to or exceeds four (4) times their width-
 - (i) blocking at each support must be provided in accordance with Figure 3.4.3.4; and
 - (ii) herringbone strutting or solid blocking must be provided in evenly spaced rows between joists in accordance with the following:
 - (A) For spans not more than 3 m - not *required*.
 - (B) For spans over 3 m and not more than 4.2 m - one row.
 - (C) For spans over 4.2 m and not more than 6 m - two rows.

Amdt 3

11,654

[Next page is 11,701]

3.4.3.4 Flooring

- (a) Flooring may be laid as a platform floor or fitted in accordance with Figure 3.4.3.5.
- (b) Strip tongue and groove flooring must be-
 - (i) fixed with 50 x 2.8 mm diameter bullet head nails hand driven or 50 x 2.5 mm diameter nails machine driven; and
 - (ii) be installed in accordance with Table 3.4.3.1.
- (c) Plywood structural flooring must be-
 - (i) manufactured in accordance with AS 2269; and
 - (ii) installed in accordance with Table 3.4.3.2.

**Figure 3.4.3.4
BLOCKING FOR DEEP JOISTS**

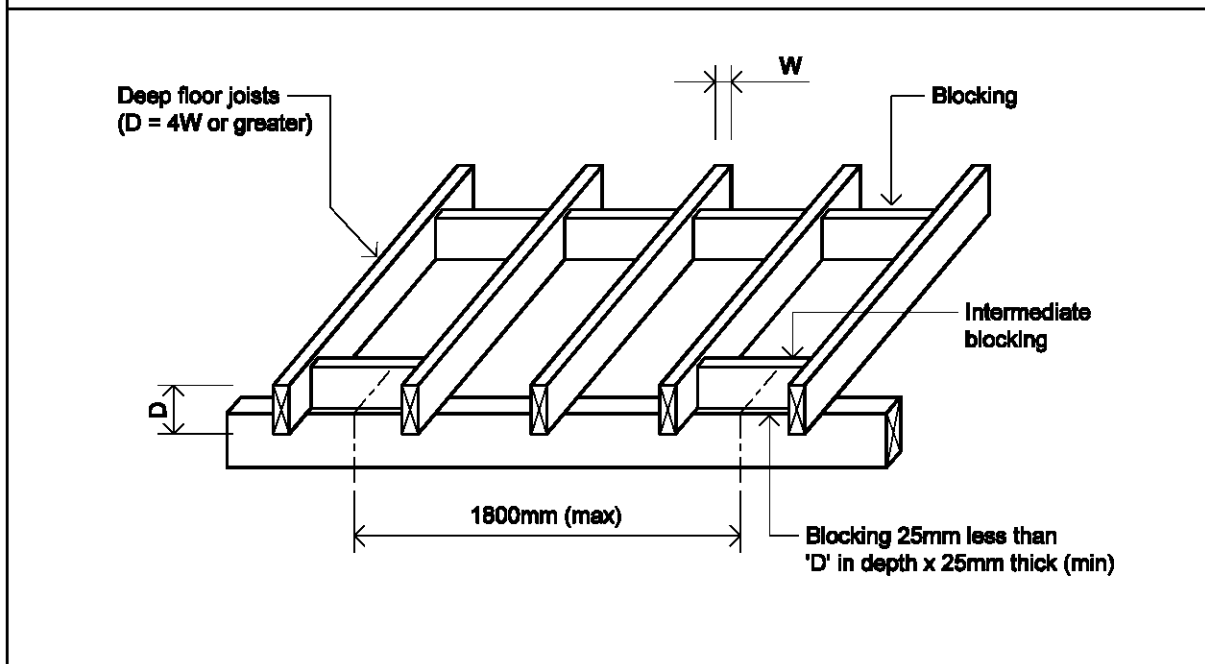

- (d) Particleboard structural sheet flooring must be-
 - (i) manufactured in accordance with AS 1859; and
 - (ii) installed in accordance with Table 3.4.3.3 and AS 1860.
- (e) Where tongue and groove platform floors are laid, joists may be located without reference to the position of walls except that double joists must be used under external and internal *loadbearing* walls.

Figure 3.4.3.5
PLATFORM AND FITTED FLOORS

Diagram a. Non Loadbearing Walls On Platform Floors

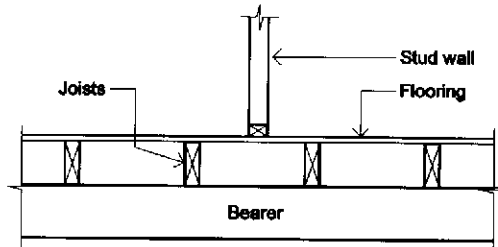

Diagram b. Fitted Floors

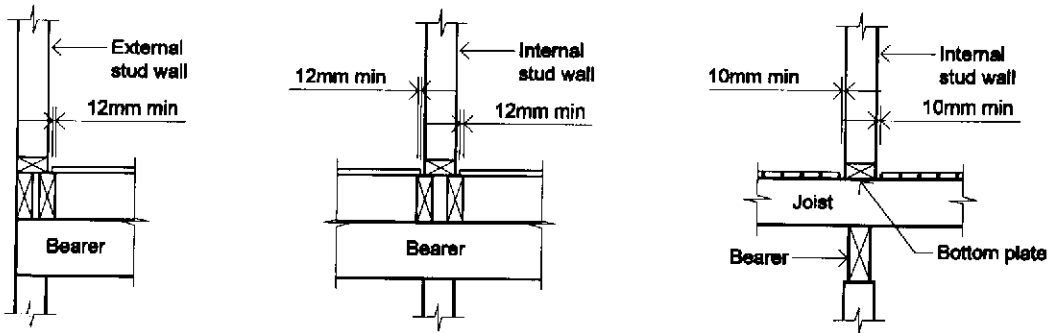

Table 3.4.3.1
T & G STRIP FLOORING

TIMBER	VISUAL GRADE	THICKNESS (mm)	FLOOR JOIST SPACING (mm)	
			BUTTED OVER JOISTS	END-MATCHED
HARDWOOD				
Density. 400-560 kg/m ³	Standard and select	19	510	390
560-720 kg/m ³	Standard and select	19	580	450
720 plus kg/m ³	Utility	19	580	450
	Standard	19	640	490
	Select	19	680	520
AUSTRALIAN GROWN CONIFERS				
Density less than 560 kg/m ³	Standard	19	510	390
Density greater than 560 kg/m ³	Standard	19	580	450
RADIATA PINE	Standard	19	510	390
CYPRESS	Seasoned One Grade	20	580	450

Amdt 3

Table 3.4.3.2 PLYWOOD FLOORING			
STRUCTURAL PLYWOOD THICKNESS (mm)	MAXIMUM JOIST SPACING (mm)		MINIMUM FIXING REQUIREMENTS TO TIMBER
	F11	F14	
12	420	440	Plywood face grain must run at right angles to the joists. Nails: Min. 2.8 mm Ø x 2.5 times plywood thickness. Screws: No. 8 x 30 mm self drilling countersunk wood screws. Fixing Spacing: 150 mm centres at end joints, 300 mm centres at intermediate joints
13	450	480	
15	520	540	
17	560	600	
19	620	660	

Amdt 3

Table 3.4.3.3 PARTICLEBOARD FLOORING		
PARTICLEBOARD THICKNESS (mm)	MAXIMUM JOIST SPACING (mm)	MINIMUM FIXING REQUIREMENTS TO TIMBER JOISTS
19	450	Adhesive is mandatory between joists and floor. Nails: 50 x 2.8 mm Ø galv. nails for hardwood and cypress joists and 65 x 2.8 Ø nails for softwood joists. Screws: No. 10 x 50 mm Type 17 self drilling countersunk screws. Fixing Spacing: 50 mm centres at butt edges; and 300 mm centres at intermediate joists.
22	600	

Explanatory information:

The amount of shrinkage likely to occur in unseasoned hardwood is around 7-10%. Care should be taken when using large unseasoned sections, and the use of adjacent timber members having different shrinkage characteristics should be avoided. For example, the use of large section timber blocks under bearers and joists to create steps in timber floors can be avoided by placing piers or stumps on both sides of the change in level, with each stump supporting comparable sized bearers and joists.

3.4.3.5 Wall framing

Timber wall framing must be constructed in accordance with the following requirements:

- (a) Housing, notching, drilling, cutting and trenching of wall framing must be within the limits given in Figure 3.4.3.6.

Figure 3.4.3.6
HOUSING, NOTCHING, DRILLING, CUTTING AND TRENCHING

Notes:

1. Where holes are smaller than the maximum permitted size, they may be located at closer spacings than those given provided their combined size is less than the maximum permitted size for a single hole.
2. Stud notching for bracing is not permissible where studs are designed as un-notched.
3. Plate trenching is not permissible where plates are designed as un-trenched.

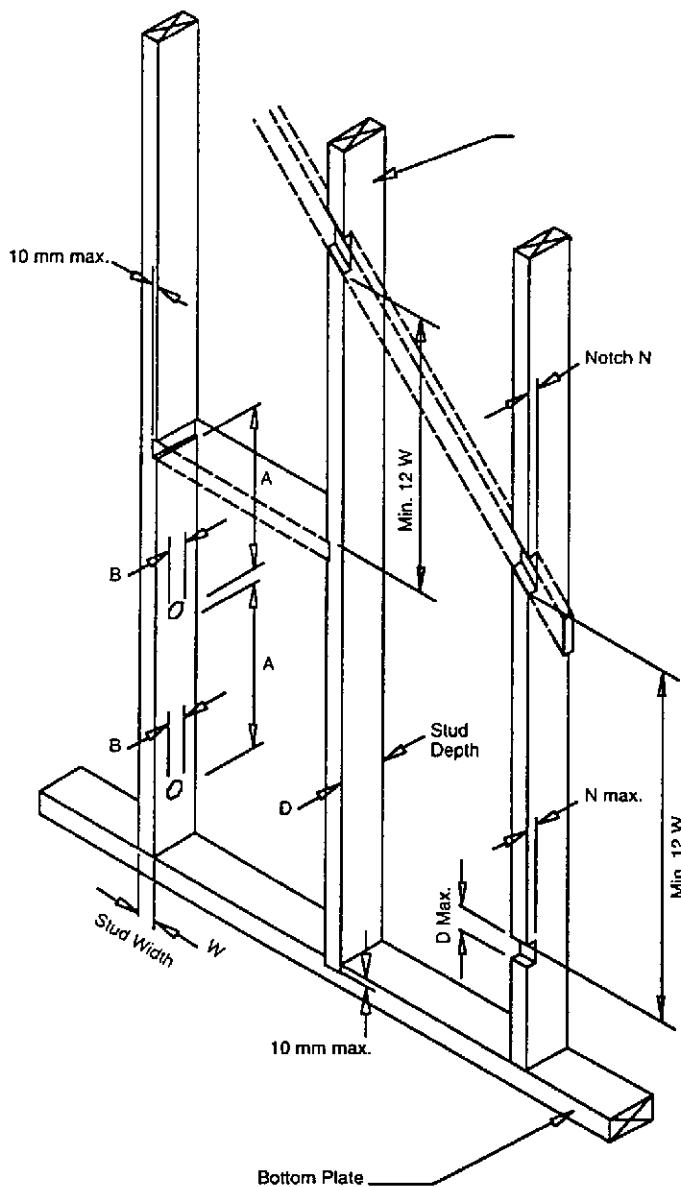

Notch and hole limitations:

Notching (N)

Single or upper storey construction:
N = 20 mm max.

Hole diameter (B)

Unseasoned hardwood D/3 max.
Seasoned hardwood D/4 max.
Seasoned softwood D/3 max.
Unseasoned softwood D/3 max.

Distance between holes/notches (A)

Hardwood 3 x D min.
Seasoned softwood 2 x D min.

- (b) Joining of wall plates must comply with the following:
 - (i) Top wall plates must be joined at wall intersections or within the length of the wall by using noggings or metal nail plates to ensure continuity.
 - (ii) Butt joints in bottom plates are permitted provided ends of plates are fully supported.
- (c) Wall plates supporting major loads must comply with the following:
 - (i) Where top or bottom plates are required to support major point loads arising from roof struts, strutting beams, hanging beams, girder trusses and bearers, they must be strengthened in accordance with Figure 3.4.3.7.
 - (ii) Where major loads occur, the studs directly under the load or adjacent studs either side must be determined as studs supporting concentrated loads.

Amdt 3

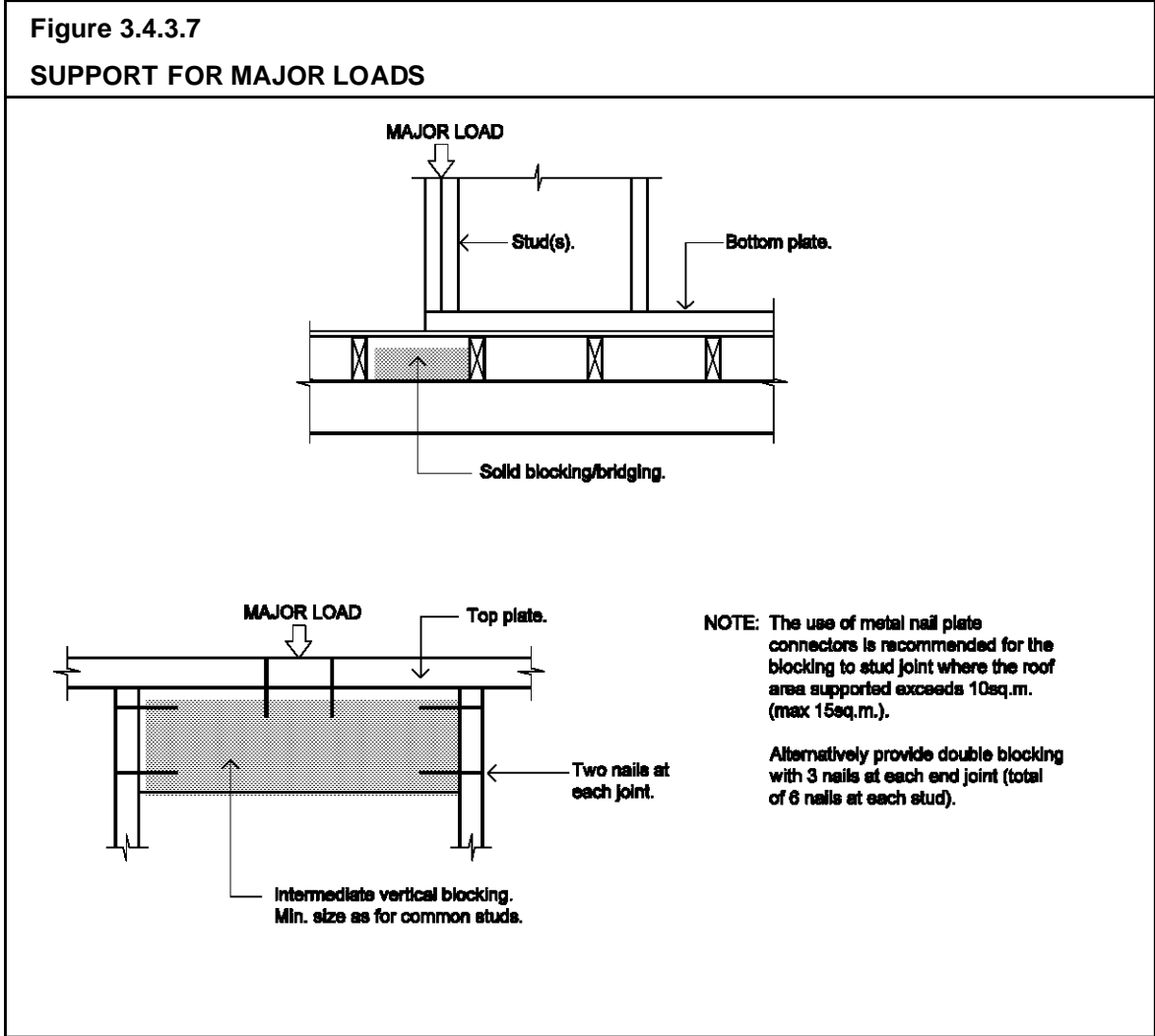

(d) Lintels

Lintels must be installed in accordance with Figure 3.4.3.8.

**Figure 3.4.3.8
TYPICAL LINTEL INSTALLATION DETAILS**

Notes:

1. The use of unseasoned timber for lintels is not recommended where the lintel depth is more than 175 mm (hardwood) or 300 mm (softwood) unless provision is made to minimise the effect of shrinkage (eg. use of a ledger as per Method B).
2. With Methods B and C it is permissible to locate the lintel immediately beneath the top plate with the top plate fixed to the lintel.
3. With Method B it is permissible to locate the first common stud immediately adjacent to the stud at side of opening with the combined width determined as Method C.

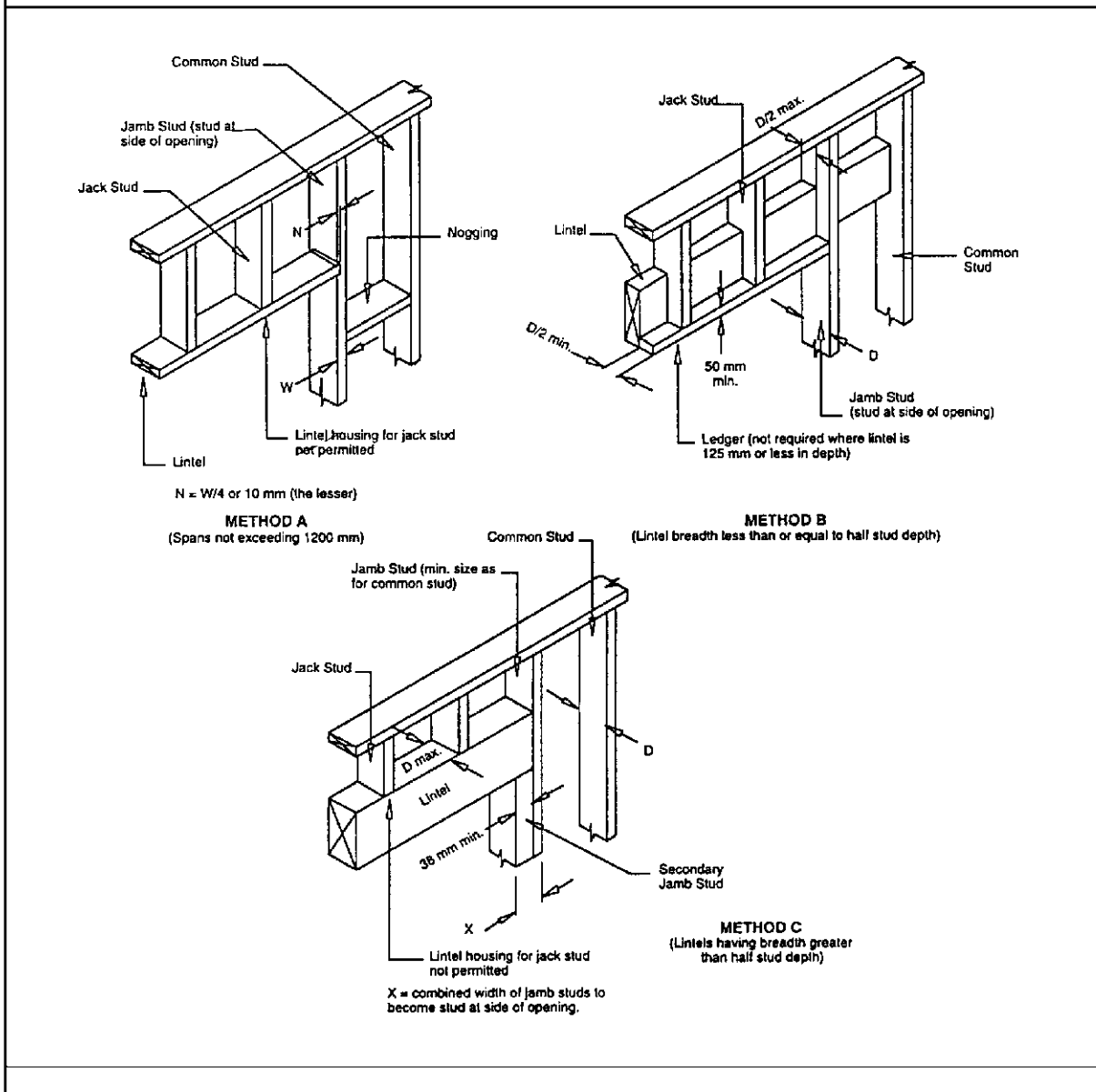

Amdt 3

- (e) Noggings must be-
- (i) installed in wall frames at not more than 1350 mm centres vertically. Additional rows may be installed where necessary for support of lining materials, fixtures, fittings etc or at openings; and
 - (ii) not less than 25 mm thick nor more than 25 mm less in depth than the stud depth; and
 - (iii) offset not more than 70 mm about the centre line of the row for alternate noggings.
- (f) Lateral support of *external walls* must be provided by-
- (i) internal walls at right angles, ceiling joists, roof trusses, ceiling or roof beams or the like, at not more than 3 m centres along the length of wall; or
 - (ii) fixing the ceiling frame to the wall frame at not more than 3 m centres in accordance with Figure 3.4.3.9.

Figure 3.4.3.9
BINDERS TO CONNECT WALLS TO CEILING FRAME

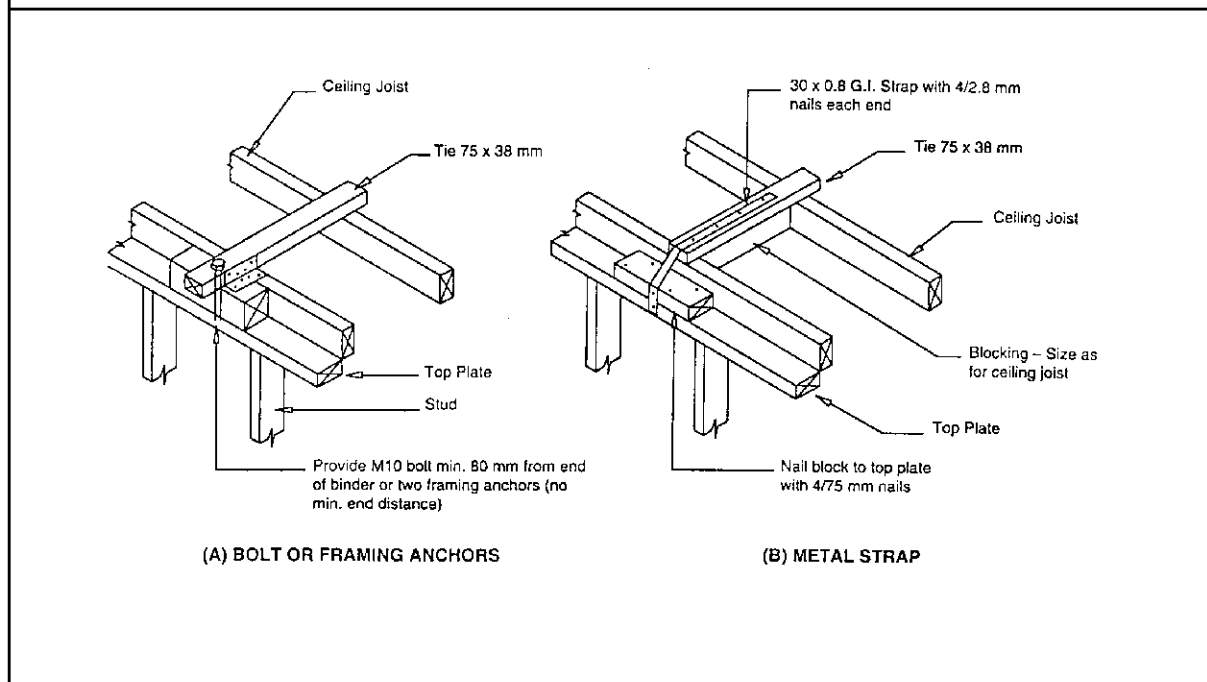

3.4.3.6 Conventional roofs

Conventional roof systems including roof beams, cathedral, skillion and coupled roofs, strutted or unstrutted, must be constructed in accordance with the configurations described in one of the acceptable construction manuals listed in 3.4.3.0 and the following:

- (a) Ceiling joists must be-
 - (i) single lengths or joined at supports by either butt joining with 25 mm thick fishplates or lapped not less than three times the depth of the joist. Splices in ceiling joists must be nailed together, using 6/75 mm nails to each plate on each side of the join; and
 - (ii) fixed to the top plate and rafter with nominal fixings; and
 - (iii) similar in spacing and direction to the main roof rafters so that when fixed they act as ties between opposing rafters.
- (b) Hanging beams must be-
 - (i) fixed to ceiling joists with timber or metal ceiling ties on alternate sides of the beam; and
 - (ii) supported by blocking under the beam at each support point; and
 - (iii) securely fixed in place in accordance with Figure 3.4.3.10.

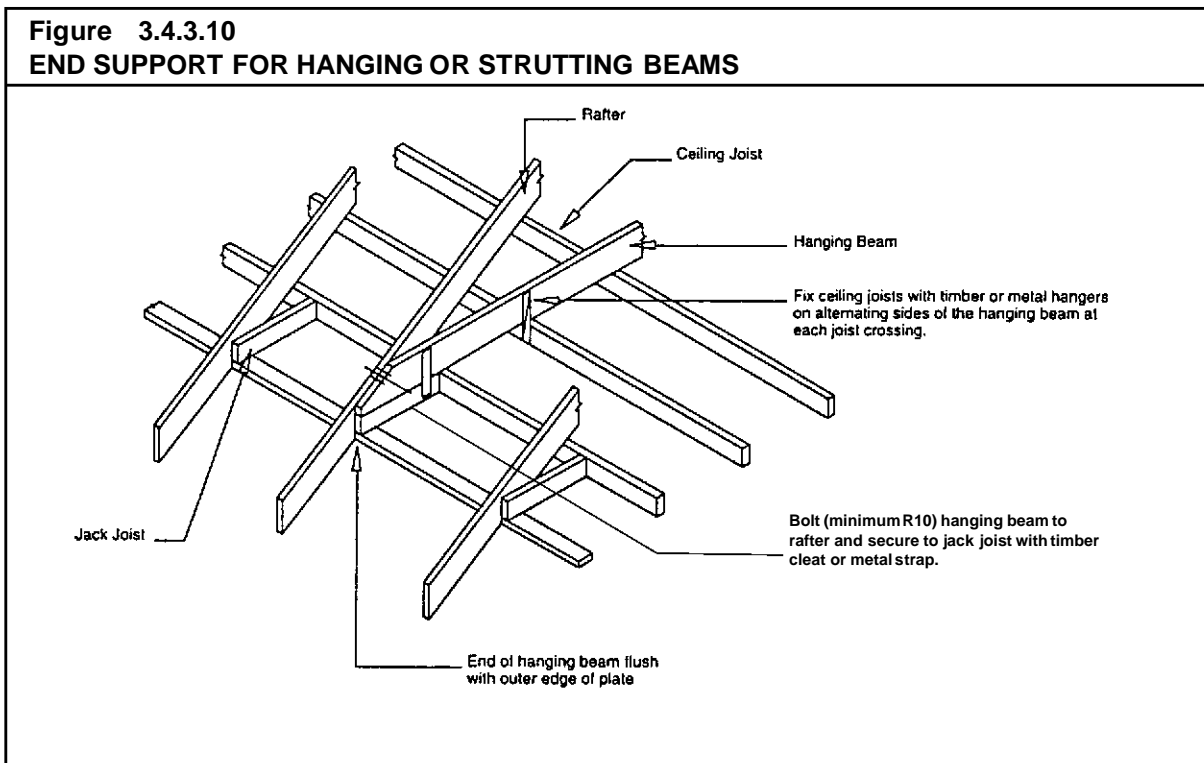

- (c) Rafters must comply with the following:
- (i) Rafters must be nominally fixed to top plates and adjoining ceiling joists at one end and to the ridge board, hip or valley rafter at the other end; and be-
 - (A) single length members; or
 - (B) lapped 6 x depth, bolted with 2/10 mm steel bolts and directly supported by an underpurlin.
 - (ii) Rafters may be supported by one or more underpurlins between the ridge and top plate.
 - (iii) The depth of birdsmouthing must not be more than one third of the rafter depth in accordance with Figure 3.4.3.11.

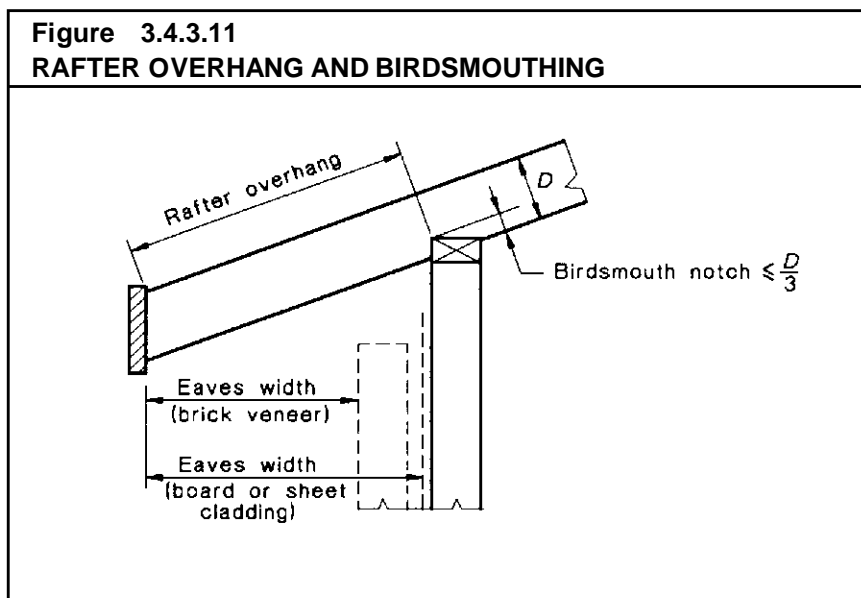

- (d) Ridge Boards must comply with the following:
- (i) Ridge boards must be of sufficient depth to give full bearing to the upper end of rafters and not less than 25 mm thick.
 - (ii) Opposing pairs of rafters must not be separated by more than their own thickness at either side of their ridge junction.
 - (iii) Where the junction between a hip or valley rafter and the ridge is *required* to be strutted, the full length of the ridge must be strutted as follows:
 - (A) 25 mm thick ridge boards - strutted at 1.8 m centres.
 - (B) 35 mm or 38 mm ridge boards - strutted at 2.3 m centres.

- (iv) Where ridge boards are joined, the join must be closely butted with 25 mm thick full depth timber fishplates each side, not less than 600 mm long or alternatively scarf jointed. 6/65 mm nails must be provided to each plate on each side of the join in accordance with Figure 3.4.3.12.

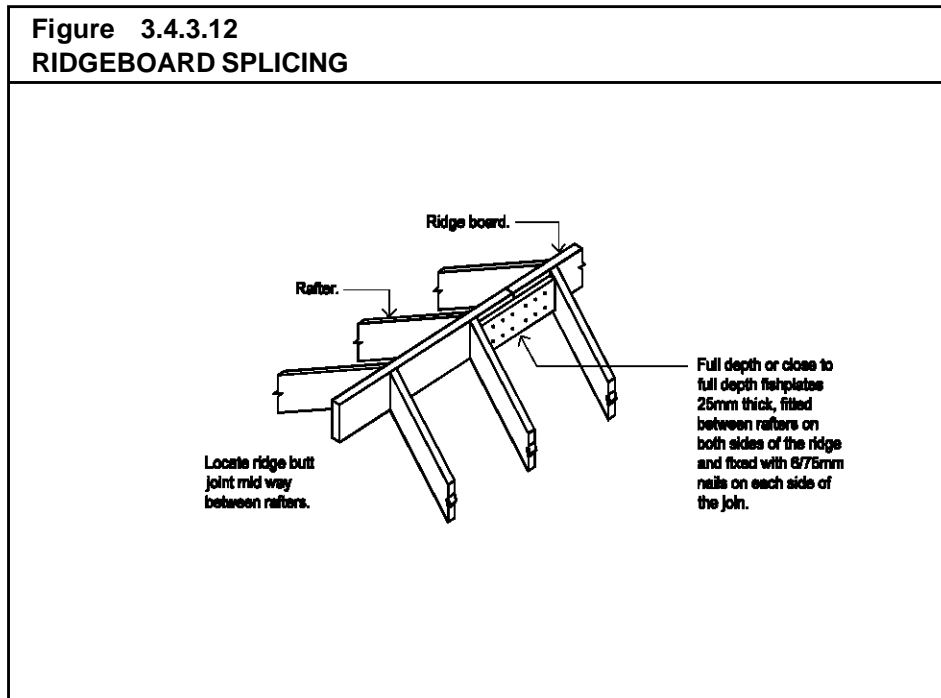

- (e) Underpurlins used to provide intermediate support to rafters must be installed as follows:
- (i) Underpurlins must be single lengths (where possible) and positioned at right angles to the direction of the rafters.
 - (ii) Single underpurlins must be located at or near the mid length of the rafters.
 - (iii) Where two or more underpurlins are used they must be equally spaced between the ridge and eaves.
 - (iv) Where underpurlins are joined in their length, the join must be halved and lapped, spiked together and located over a point of support.
 - (v) The ends of underpurlins must not cantilever by more than 25 percent of the allowable span (see Figure 3.4.3.13).
 - (vi) Where hip, valley or jack rafters are *required* to act as supports for underpurlins, a tie-bolt truss or equivalent support system may be provided.

Figure 3.4.3.13
HIP END CONSTRUCTION

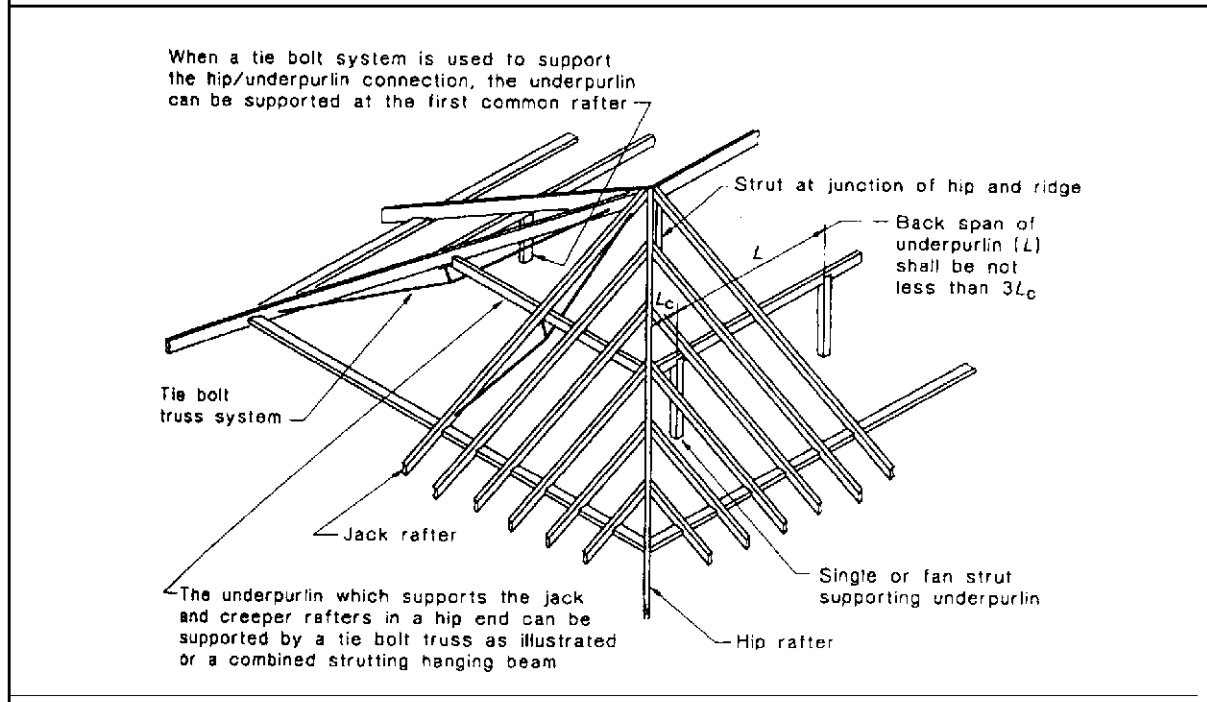

- (f) Hip or valley rafters must comply with the following:
- (i) Hip rafters must be 50 mm greater in depth and may be up to 13 mm less in width than the adjacent common rafters.
 - (ii) Valley rafters must be 50 mm greater in depth than the adjacent common rafters and may be 38 mm in width.
 - (iii) Where hip or valley rafters are supported by underpurlins or struts they must have the same number of evenly spaced intermediate supports as the common rafters.
 - (iv) Where valley rafters are supported by underpurlins the valley rafter must be supported from both directions.
 - (v) Support for hip rafters may be from one direction only.
 - (vi) Where the underpurlins are supported by a hip or valley rafter in conjunction with a tie-bolt truss system spanning more than 5 m, a strut must be provided at the junction of the hip or valley rafter and the ridge board.
 - (vii) In hipped roofs where common rafters are projected to form overhangs equal to or more than 600 mm, the breadth of hip rafters must be increased to at least the breadth of the common rafters unless suitable reinforcing (such as fishplates extending 450 mm on either side of the birdsmouth) is provided.

- (g) Roof struts supporting roof members must be located so that they transfer loads to the footings by the most direct route and:
 - (i) Single roof struts must be fixed at an angle not more than 30 degrees from the vertical in accordance with Figure 3.4.3.14.
 - (ii) Fan struts must be installed in accordance with Figure 3.4.3.14.
 - (iii) Struts must be halved to the supported member and be supported on *loadbearing* walls or strutting beams in accordance with Figure 3.4.3.14.

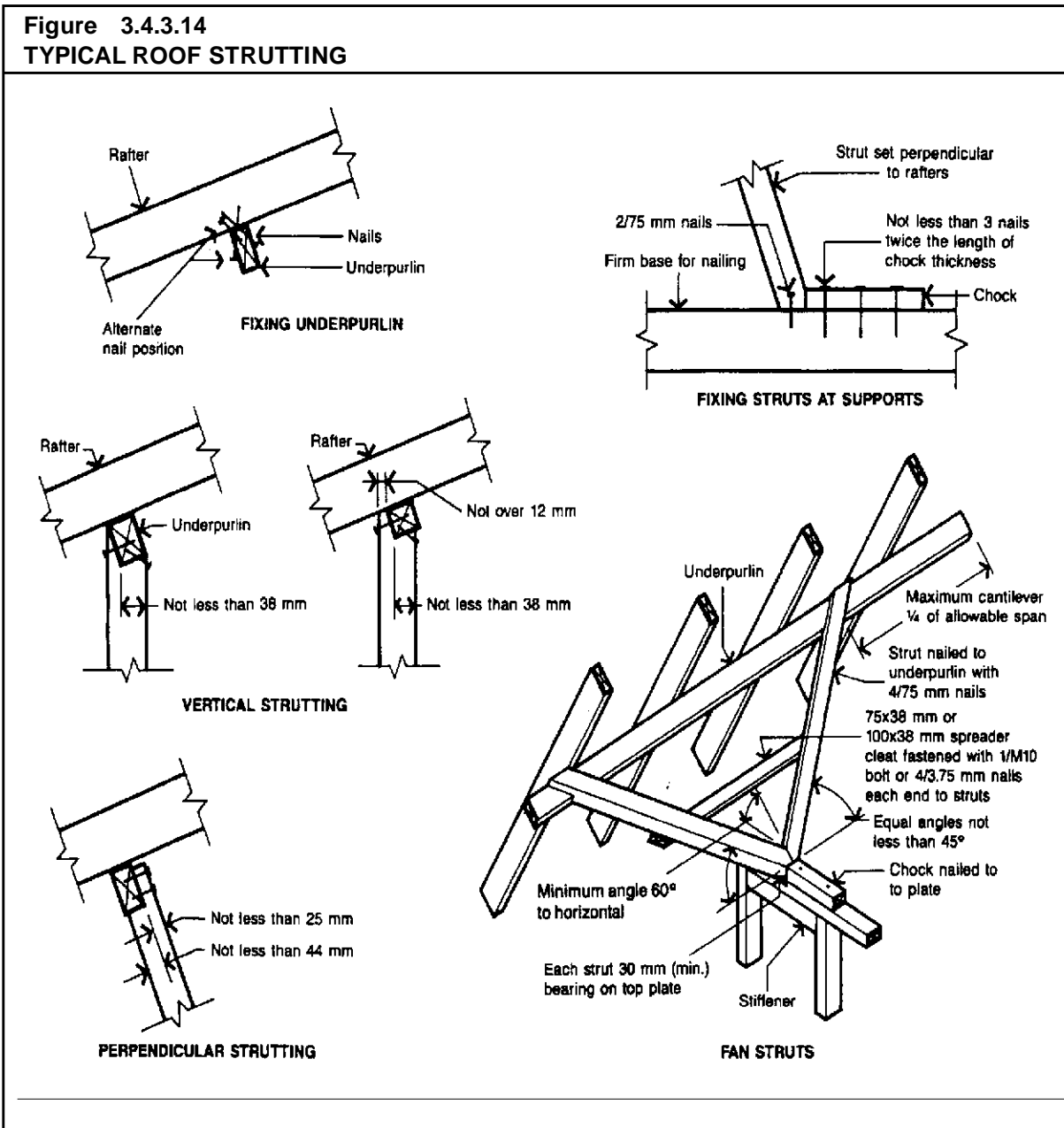

Amdt 3

11,804

[Next page is 11,851]

- (h) Strutting beams must be installed in accordance with Figures 3.4.3.15, 3.4.3.10 and the following:
 - (i) Strutting beams may extend in any direction in the roof space provided-
 - (A) their ends are supported on *loadbearing* walls; and
 - (B) a clearance of not less than 25 mm is provided between the underside of the strutting beam and the ceiling or ceiling joists by blocking up the ends of the beam from the top plate.
 - (ii) The ends of strutting beams may be chamfered to avoid interference with roof cladding on low pitched roofs provided the end is reduced by not more than the amount shown in Figure 3.4.3.15.

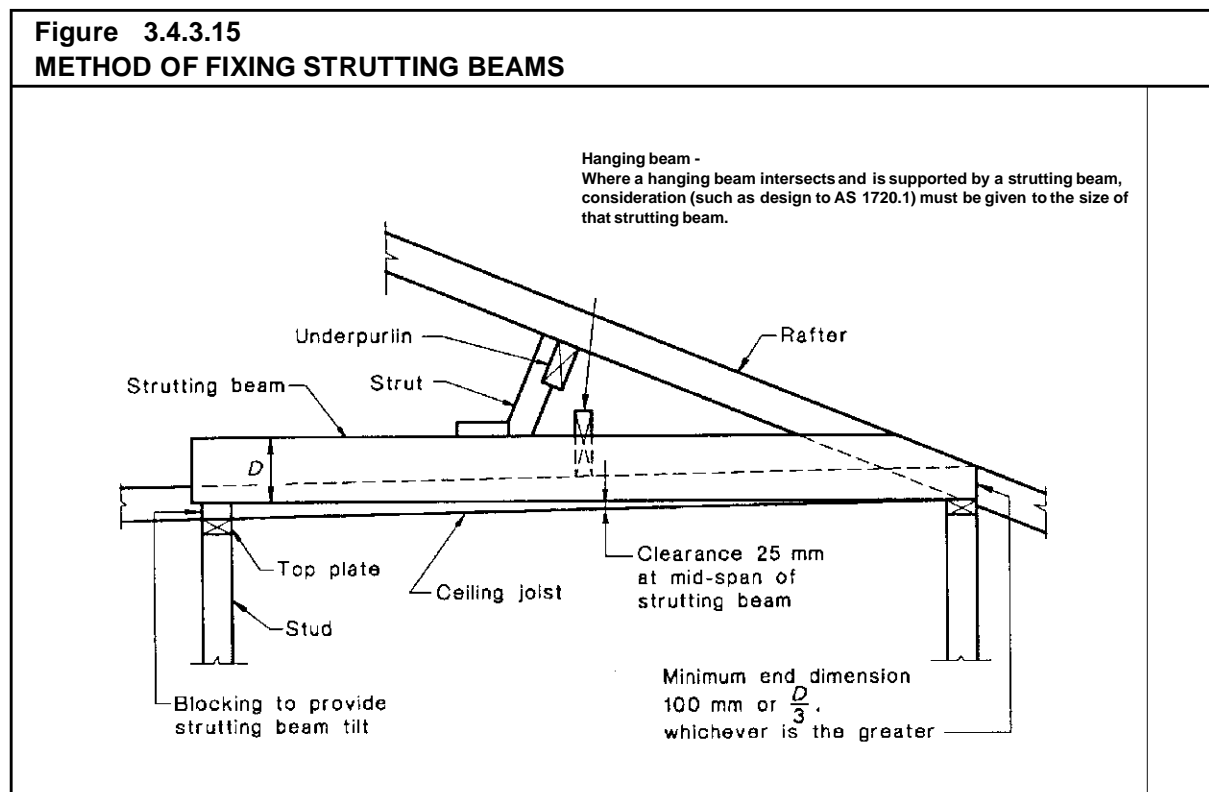

- (i) In roofs with a pitch of more than 10 degrees, collar ties must be fixed to each alternate pair of common rafters in accordance with Figure 3.4.3.16 with-
 - (i) 2/75 mm nails each end for collar ties not more than 4.2 m long; or
 - (ii) one M10 bolt for collar ties more than 4.2 m long.

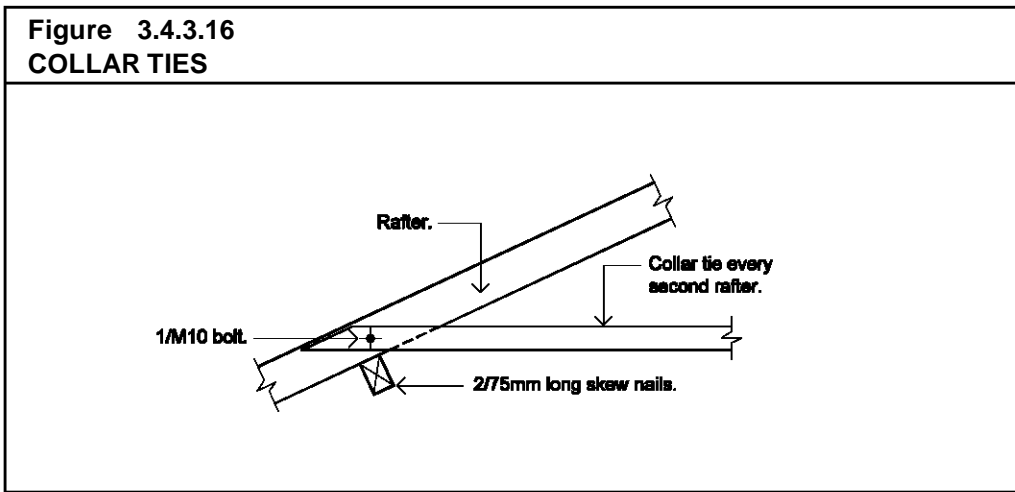

- (j) Roof beam construction (cathedral, skillion, exposed rafter etc.) is considered to be large section rafters that are not birdsmouthed over wall plates and must be installed to ensure that the roof is stable and does not impart unbalanced lateral loads onto *external wall* frames (see Figure 3.4.3.17).

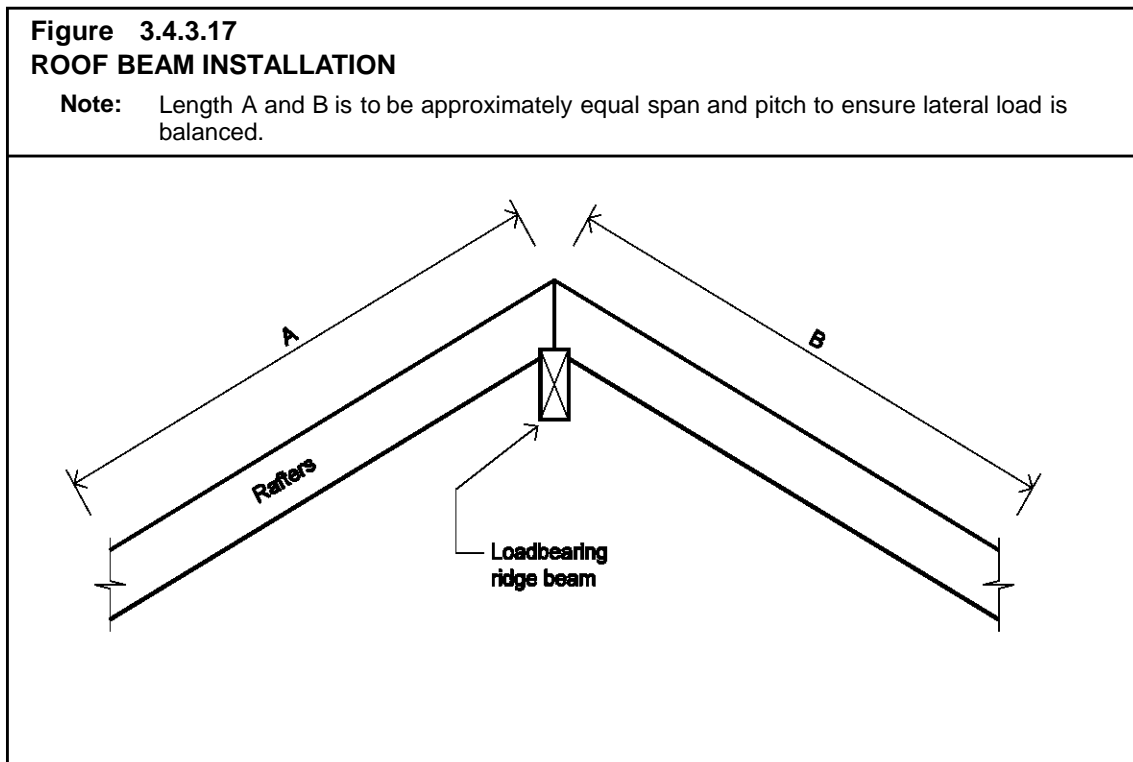

Amdt 3

3.4.3.7 Acceptable timber frame sizes and fixing

A timber frame must be constructed using timber framing members with appropriate sizes and fixing as follows:

- (a) Sizes and spacings must comply with Tables 3.4.3.4 to 3.4.3.7.
- (b) A timber frame must be fixed in accordance with-
 - (i) Table 3.4.3.8 for frames in *design wind speed* areas W28 and W33; and
 - (ii) Table 3.4.3.9 for frames in *design wind speed* area W41.

Table 3.4.3.4							
FLOOR FRAMING - AREAS WITH A DESIGN WIND SPEED NOT MORE THAN W41							
Member	Unseasoned Timber			Seasoned Timber			
	F7	F8	F11	F5	F7	F17	F22
RAFTERED ROOF CONSTRUCTION - MAX. RAFTER SPAN 3 m							
Bearers - Sheet Roof (Continuous Span)	125x75	125x75	100x75	125x75	120x70	90x70	90x70
- Tile Roof (Continuous Span)	150x75	125x75	125x75	125x75	120x70	120x70	120x70
Floor Joists (Continuous Span)	100x50		100x38		120x35		
TRUSSED ROOF CONSTRUCTION - MAX. TRUSS SPAN 12 m							
Bearers - Sheet Roof (Continuous Span)	150x75	150x75	125x75	140x70	140x70	120x70	120x70
- Tile Roof (Continuous Span)	200x75	175x75	150x75	190x70	170x70	170x70	120x70
Floor Joists (Continuous Span)	100x50	100x38	100x38	120x35	90x45	90x45	90x35

Amdt 3

Table 3.4.3.5							
WALL FRAMING - AREAS WITH A DESIGN WIND SPEED NOT MORE THAN W41							
Note: All dimensions are member depth x breadth and expressed in mm.							
Member	Unseasoned Timber			Seasoned Timber			
	F7	F8	F11	F5	F7	F17	F22
RAFTERED ROOF CONSTRUCTION - MAX. RAFTER SPAN 3 m							
Bottom Plate - Sheet Roof	75x75	50x75	50x75	2/35x90	70x70	45x70	35x70
- Tile Roof	75x75	75x75	50x75	2/35x90	70x70	45x70	45x70
Studs - Sheet Roof	75x38	75x38	75x38	90x35	70x45	70x35	70x35
- Tile Roof	75x38	75x38	75x38	90x35	70x45	70x35	70x35
Top Plate - Sheet Roof	50x75	50x75	75x75	2/35x90	90x70	35x70	35x70
- Tile Roof	75x75	50x75	50x75	2/35x90	70x70	45x70	35x70
Jamb Studs - Sheet Roof							
Opening 1200	75x75	75x75	75x38	90x45	70x45	70x45	70x45
1500	75x75	75x75	75x75	90x45	70x90	70x70	70x70
1800	75x100	75x75	75x75	90x70	70x90	70x70	70x70
2400	75x100	75x100	75x75	90x70	70x90	70x70	70x70
- Tile Roof							
Opening 1200	75x75	75x75	75x38	90x45	70x45	70x45	70x45
1500	75x75	75x75	75x75	90x45	70x90	70x70	70x70
1800	75x100	75x75	75x75	90x70	70x90	70x70	70x70
2400	75x100	75x100	75x75	90x70	70x90	70x70	70x70
Lintels - Sheet Roof							
Opening 1200	50x75	50x75	75x75	45x90	90x70	45x70	45x70
1500	100x75	75x75	75x75	90x45	120x70	45x70	45x70
1800	100x75	100x75	100x75	120x45	120x70	90x35	90x35
2400	150x75	150x75	150x75	140x70	170x70	120x35	90x70
- Tile Roof							
Opening 1200	100x75	100x75	75x75	90x70	90x70	45x70	45x70
1500	125x75	125x75	100x75	120x70	90x70	90x35	90x35
1800	150x75	150x50	175x75	120x70	120x70	120x35	90x70
2400	200x75	200x75	175x75	170x70	170x70	140x70	120x70
TRUSSED ROOF CONSTRUCTION - MAX. TRUSS SPAN 12 m							
Bottom Plate- Sheet Roof	75x100	75x75	75x75	70x90	70x90	2/45x70	45x70
- Tile Roof	75x100	75x100	75x75	---	70x90	2/45x70	2/45x70
Studs - Sheet Roof	100x38	100x50	75x38	90x45	90x35	70x35	70x35
- Tile Roof	100x38	100x38	75x38	90x45	90x35	70x35	70x35
Top Plate - Sheet Roof	75x100	75x75	75x75	70x90	70x90	45x70	45x70
- Tile Roof	75x100	75x100	75x75	---	70x90	2/45x70	2/45x70
Jamb Studs - Sheet Roof							
Opening 1200	100x38	75x75	75x38	90x45	90x45	70x45	70x45
1500	100x38	75x75	75x75	90x70	90x70	70x70	70x70
1800	100x50	75x75	75x75	90x70	90x70	70x70	70x70
2400	100x50	75x100	75x75	90x70	90x70	70x70	70x70
- Tile Roof							
Opening 1200	100x75	100x50	75x38	90x70	90x45	70x45	70x45
1500	100x75	100x75	75x75	90x90	90x70	70x70	70x70
1800	100x75	100x75	75x75	90x90	90x70	70x70	70x70
2400	100x100	100x75	75x75	90x105	90x70	70x70	70x70
Lintels - Sheet Roof							
Opening 1200	125x50	100x75	100x75	120x70	140x70	90x35	90x35
1500	150x50	125x75	125x75	140x70	170x70	90x70	90x70
1800	175x75	150x75	150x75	140x70	190x70	120x70	120x70
2400	225x75	200x75	200x75	190x70	240x70	170x70	170x70
- Tile Roof							
Opening 1200	150x75	125x75	125x75	170x70	120x70	90x35	90x35
1500	175x75	175x75	150x75	190x70	170x70	120x70	120x70
1800	200x75	200x75	200x75	240x70	190x70	140x70	140x70
2400	275x75	275x75	250x75	290x70	240x70	190x70	170x70

Amdt 3

Table 3.4.3.6							
ROOF FRAMING - AREAS WITH A DESIGN WIND SPEED NOT MORE THAN W33							
Note: All dimensions are member depth x breadth and expressed in mm.							
Member	Unseasoned Timber			Seasoned Timber			
	F7	F8	F11	F5	F7	F17	F22
RAFTER ROOF CONSTRUCTION - MAXIMUM RAFTER SPAN 3 m							
Ceiling Joists (600 crs.) (Continuous Span Max. 3.0m)	125x38	125x38	125x38	120x45	120x35	120x35	90x45
Hanging Beams (Maximum Span 4.2 m)	275x50	300x38	250x50	240x45	240x45	190x45	190x45
Strutting Beams - Sheet Roof - Tile Roof (Maximum Span 4.2m)	275x75 ---	275x75 ----	250x75 ----	240x90 ---	240x90 290x90	190x70 290x90	190x70 290x90
Underpurlins - Sheet Roof - Tile Roof (Continuous Span Max. 1.8m)	100x75 150x75	100x50 125x75	100x50 125x75	120x70 140x70	90x70 120x70	70x70 90x70	70x70 90x70
Rafters - Sheet Roof - Tile Roof (Continuous Span Max. 3.0m)	100x50 150x38	100x38 125x50	100x38 125x50	120x35 120x45	120x35 120x45	90x35 120x35	90x35 120x35
TRUSSED ROOF CONSTRUCTION - MAXIMUM TRUSS SPAN 12 m							
Trusses, Connections, Bracing	To be engineer designed and certified						

Table 3.4.3.7							
ROOF FRAMING - AREAS WITH A DESIGN WIND SPEED OF NOT MORE THAN W41							
Note: All dimensions are member depth x breadth and expressed in mm.							
Member	Unseasoned Timber			Seasoned Timber			
	F7	F8	F11	F5	F7	F17	F22
RAFTER ROOF CONSTRUCTION - MAXIMUM RAFTER SPAN 3 m							
Underpurlins - Sheet Roof (Continuous Span max. 1.8m)	125x75	125x50	100x75	120x70	120x70	70x70	70x70
Rafters - Sheet Roof (Continuous Span max. 3.0m)	125x38	100x50	100x38	140x45	120x45	90x35	90x35
All Other Members	As per Table 3.4.3.6 above						

Amdt 3

PART 3.4.3 - TIMBER FRAMING

Table 3.4.3.8

CONNECTION/FIXINGS FOR AREAS WITH A DESIGN WIND SPEED OF W28 AND W33

Notes:

1. For effective skew nailing, the nail must be driven into one member not closer than 25 mm or more than 38 mm from the arris in contact with the adjoining member. The nail must be driven at an angle between 30 and 45 degrees to the face into which the nail is being driven.
2. Nails which are smaller than the nominated size, are other than plain shanked and/or are machine driven may be used providing their performance is not inferior to the nail sizes given below.

JOINT	MINIMUM FIXING FOR EACH JOINT
<p>Floor Framing</p> <p>Bearer to Timber Stump/Post</p> <p>Bearer to Masonry Column/Wall/ Pier (excluding brick veneer construction)</p> <p>Bearer to Concrete Stump /Post or Pier in masonry veneer.</p> <p>Bearers to Steel Post</p> <p>Floor Joist to Bearer</p>	<p>(a) Four 75 mm x 3.75 mm Ø nails plus one 30 mm x 0.8 mm galvanised steel strap over bearer and fixed both ends to stump with four 2.8 mm Ø nails each end; or</p> <p>(b) One M10 bolt through bearer halved to stump; or</p> <p>(c) One M12 cranked bolt fixed vertically through bearer and bolted to stump plus four 75 mm x 3.75 mm Ø nails.</p> <p>One M10 bolt or One 50 mm x 4 mm M.S. bar fixed to bearer with M10 bolt and cast into masonry (to footing).</p> <p>One 6 mm Ø rod cast into stump, vertically through bearer and bent over.</p> <p>One M10 coach screw or bolt.</p> <p>Two 75 mm x 3.1 mm Ø nails</p>
<p>Wall Framing</p> <p>Plates to Studs</p> <p>Noggings to Studs</p> <p>Timber Braces to Studs or Plates</p> <p>Bottom Plates to Joists</p> <p>Bottom Plates to Concrete Slab</p> <p>Multiple Studs</p> <p>Posts to Bearers or Joists</p>	<p>(a) Plates up to 38 mm thick - two 75 mm nails through plate; or</p> <p>(b) Plates 38 to 50 mm thick - two 90 mm nails through plate; or</p> <p>(c) two 75 mm nails skewed or through nailed.</p> <p>Two 75 mm nails skewed or through nailed.</p> <p>Two 50 mm x 2.8 mm Ø nails at each joint.</p> <p>(a) Plates up to 38 mm thick - two 75 mm nails at 600 mm (max.) centres; or</p> <p>(b) Plates 38 to 50 mm thick - two 90 mm nails at 600 mm (max.) centres.</p> <p>Masonry anchor, screw or bolt at not more than 1.2 m centres.</p> <p>One 75 mm nail at 600 mm centres (max.)</p> <p>One M12 or two M10 bolts (unless otherwise specified for tie-down).</p>
<p>Roof Framing</p> <p>Roof Trusses to Top Plates</p> <p>Ceiling Joists to Top Plates</p> <p>Rafters to Top Plates</p> <p>Collar Ties to Rafters</p> <p>Verandah Plates and Roof Beams to Post</p>	<p>(a) To manufacturers recommendations; or</p> <p>(b) One framing anchor with three nails to each leg.</p> <p>(c) One 30 mm x 0.8 mm G.I. strap over truss with strap ends fixed to plate with three 2.8 mm Ø nails plus two 75 mm skew nails.</p> <p>Two 75 mm skew nails plus where adjoining a rafter, one M10 bolt to every alternate rafter.</p> <p>(a) Two 75 mm skew nails plus where adjoining a ceiling joist one 75 mm nail; or</p> <p>(b) one 90 mm nail fixing joist to rafter.</p> <p>One M10 bolt for ties over 4.2 m or two 75 mm nails for ties up to 4.2 m long.</p> <p>One M12 or two M10 bolts (unless otherwise specified for tie-down).</p>

Amdt 3

Table 3.4.3.9

CONNECTION/FIXINGS FOR W41

Legend: Nominal = Nominal Connection, refer Table 3.4.3.8.

N/A = Not Applicable

Note: Maximum spacing of battens 330 mm tile roof, 900 mm sheet roof.

JOINT/CONNECTION POSITION	CONNECTION/FIXING METHOD			
	RAFTERED ROOF (Maximum Rafter Span 3 m)		TRUSSED ROOF (Maximum Truss Span 12 m)	
	Sheet Roof	Tile Roof	Sheet Roof	Tile Roof
Bearers to Stumps, Piers etc.	Nominal	Nominal	Nominal	Nominal
Floors Joists to Bearers	Nominal	Nominal	Nominal	Nominal
Bottom Plates to Joists	Method 1 or 2 @ each joist	Nominal	Method 1 or 2 each joist	Nominal
Bottom Plates to Slab	Method 4 to 6 @ 1.2 m crs.	Nominal	Method 4 to 6 1.2 m crs.	Nominal
Studs to Bottom Plates and Top Plates to Stud or Lintel	Method 7 to 10 @ 1.8 m crs.	Method 7 to 10 @ 1.8 m crs.	Method 9 to 10 @ 1.8 m crs.	Method 9 to 10 @ 1.8 m crs.
Studs at sides of Openings Opening up to 1.8 m 1.8 - 2.4 m	Method 11 to 15 Method 11 to 15	Method 10 to 15 Method 10 to 15	Method 13 to 15 Method 14 to 15	Method 11 to 15 Method 11 to 15
Rafters/Trusses to Top Plates, Underpurlins or Ridge	Method 17 to 21 @ each rafter/truss	Method 16 to 21 each rafter/truss	Method 19 or 21 @ each rafter/truss	Method 16 to 21 @ each rafter/truss
Roof Batten to Rafters/Trusses	Method 26 to 29	Method 22 to 29	Method 26 to 29	Method 22 to 29

Figure 3.4.3.18

CONNECTION METHODS

a. BOTTOM PLATES TO JOISTS/BEARERS

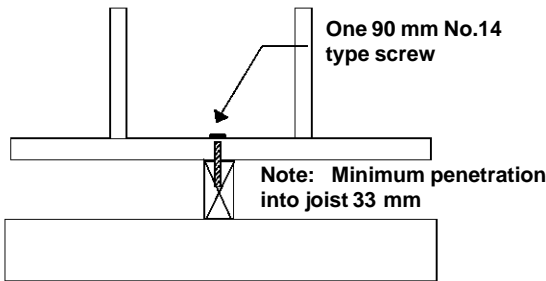
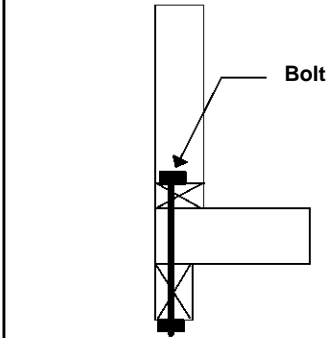
METHOD 1	METHOD 2 - use one M10 cuphead bolt METHOD 3 - use one M12 cuphead bolt
 <p>One 90 mm No.14 type screw</p> <p>Note: Minimum penetration into joist 33 mm</p>	 <p>Bolt</p>

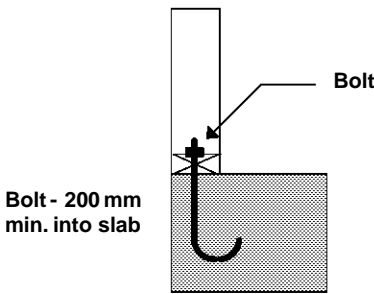
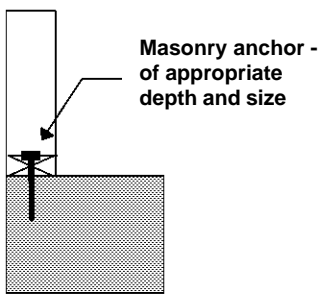
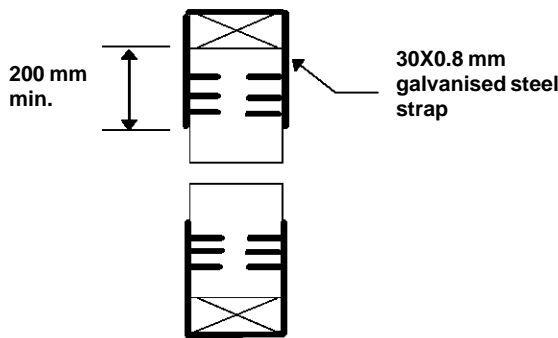
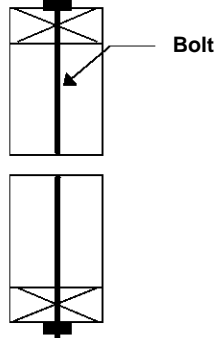
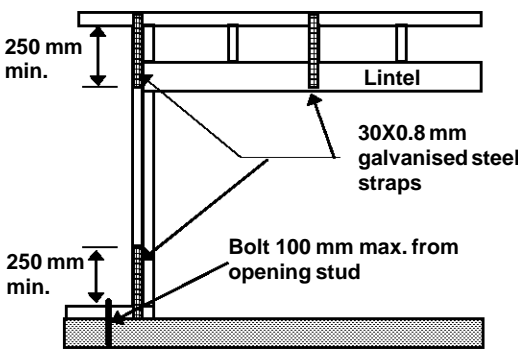
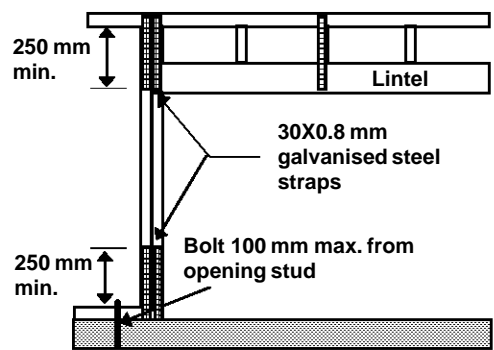
<p>Figure 3.4.3.18 (cont.) CONNECTION METHODS</p>	
<p>b. BOTTOM PLATES TO CONCRETE SLAB</p>	
<p>METHOD 4 - use 1/M10 cuphead bolt METHOD 5 - use 1/M12 cuphead bolt</p>	<p>METHOD 6</p>
	
<p>c. STUDS TO PLATES OR LINTELS (AT OPENINGS)</p>	
<p>METHOD 7 - use 3/2.8 dia. each end of strap METHOD 8 - use 4/2.8 dia. each end of strap</p>	<p>METHOD 9 - use 1/M10 cuphead bolt METHOD 10 - use 1/M12 cuphead bolt</p>
	
<p>d. STUDS AT SIDE OF OPENINGS</p>	
<p>METHOD 11 - use 3/2.8 dia. nails each end of strap</p>	<p>METHOD 12 - . 4/2.8 dia. nails each end of strap METHOD 13 - . 6/2.8 dia. nails each end of strap</p>
	

Amdt 3

<p>Figure 3.4.3.18 (cont.) FRAME CONNECTION METHODS</p>	
<p>d. STUDS AT SIDE OF OPENINGS (cont.)</p>	
<p>METHOD 14 - use 1/M10 cuphead bolt</p>	<p>METHOD 15 - use 1/M12 cuphead bolt</p>
<p>e. RAFTERS/TRUSSES TO TOP PLATES, UNDERPURLINS OR RIDGE Note: Rafters nailed to top plate with 2/75 mm skew nails.</p>	
<p>METHOD 16 - 1/framing anchor METHOD 17 - 2/framing anchors</p>	<p>METHOD 18</p>
<p>METHOD 19 - use 1/M10 cuphead bolt</p>	<p>METHOD 20 - use 30x0.8 mm strap METHOD 21 - use 2/30x0.8 mm straps</p>

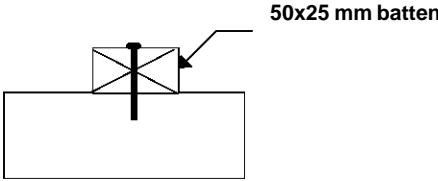
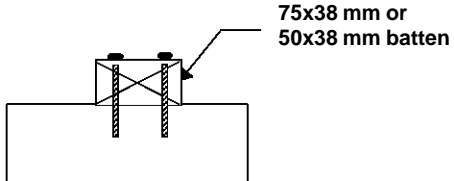
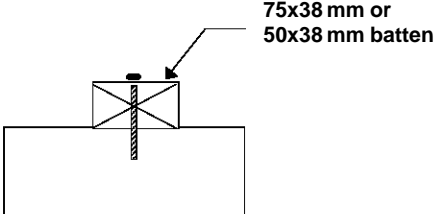
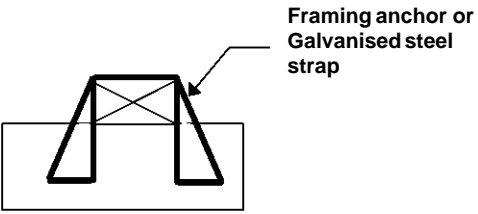
Figure 3.4.3.18 (cont.) FRAME CONNECTION METHODS	
f. ROOF BATTENS TO RAFTERS/TRUSSES	
<p>METHOD 22 - 1/65x2.8 mm nail METHOD 23 - 1/75x3.15 mm nail METHOD 24 - 1/75x3.15 mm grooved nail</p>	<p>METHOD 25 - 2/75x3.15 mm grooved nails</p>
 <p>50x25 mm batten</p> <p>Note: Minimum penetration into rafter 50 mm</p>	 <p>75x38 mm or 50x38 mm batten</p> <p>Note: Minimum penetration into rafter 38 mm</p>
<p>METHOD 26 - 1/75 mm No. 14 Type screw 38 mm min. penetration into receiving member METHOD 27 - 1/90 mm No. 14 Type screw 50 mm min. penetration into receiving member</p>	<p>METHOD 28 - use 2 framing anchors - 4/2.8 mm nails each leg METHOD 29 - use 30x0.8 mm strap - 4/2.8 mm nails each end</p>
 <p>75x38 mm or 50x38 mm batten</p>	 <p>Framing anchor or Galvanised steel strap</p>

Amdt 3

3.4.3.8 Bracing of timber frames

- (a) Timber walls must be braced in accordance with the appropriate method described in 3.4.3.8(c).
- (b) Roof framing must be braced in accordance with one of the acceptable construction manuals described in 3.4.3.0.
- (c) Wall bracing must be provided to resist horizontal forces applied to the building during and after construction as follows:
 - (i) Temporary bracing must-
 - (A) be provided during construction; and
 - (B) be equivalent to not less than 60% of the permanent bracing required in Table 3.4.3.11; and
 - (C) may consist of either part of the permanent bracing such as diagonal timber, metal angle or sheet bracing; or temporary braces; and
 - (D) be installed prior to the installation of the roof frame.
 - (ii) Permanent wall bracing must-
 - (A) be provided in accordance with the appropriate method shown in Table 3.4.3.11; and
 - (B) be at right angles to both the length and width of the building; and
 - (C) be evenly distributed as shown in Figure 3.4.3.19; and
 - (D) for every internal and *external wall*, have-
 - (aa) a diagonal timber brace or diagonal metal angle; or
 - (bb) sheet braces with a width of not less than 900 mm; and
 - (E) have two braces installed in each wall where the length of wall permits; and
 - (F) where 2 diagonal braces are used in a length of wall they must be in opposing directions; and
 - (G) be located as near as possible to external corners.

Figure 3.4.3.19

DISTRIBUTION OF BRACING WALLS

Note: $x = 9\text{ m}$ for areas with a design wind speed of W28 to W41

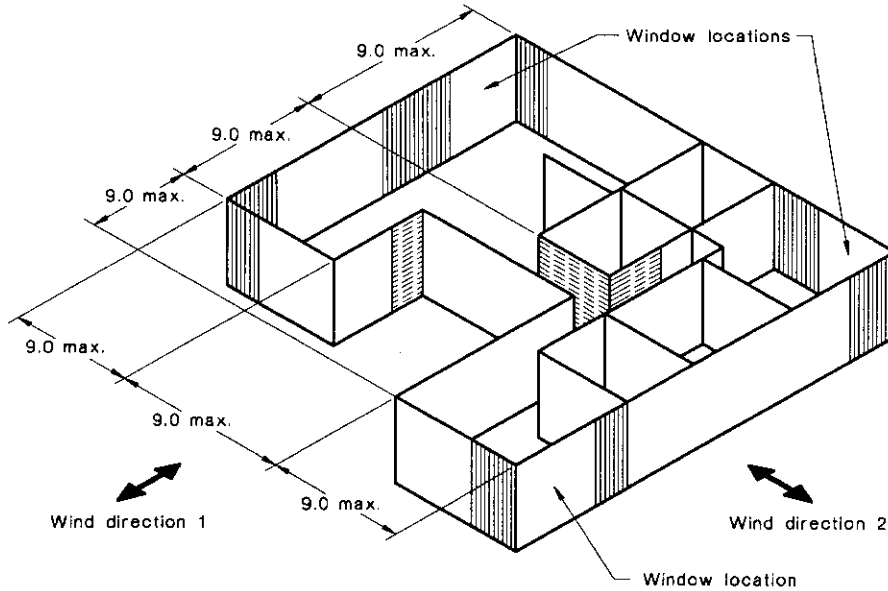

LEGEND

- = A minimum of two bracing units in each overall wall length of external walls
- = Other bracing units distributed evenly

Amdt 3

Table 3.4.3.11

WALL BRACING REQUIREMENTS

Note: For brace installation details see-

- (a) Method 1 and 2 - Figure 3.4.3.21 for metal bracing and 3.4.3.20 for sheet bracing; or
- (b) Method 3 - refer to one of the acceptable construction manuals listed in 3.4.3.0.

BUILDING WIDTH(m)	METHOD OF WALL BRACING								
	DESIGN WIND SPEED								
	W28			W33			W41		
	Roof Slope (degrees)			Roof Slope (degrees)			Roof Slope (degrees)		
	0-10	10-20	20-30	0-10	10-20	20-30	0-10	10-20	20-30
6	1	1	1	1	1	2	3	3	3
8	1	1	1	1	1	2	3	3	3
10	1	1	2	1	1	2	3	3	3
12	1	1	2	1	2	2	3	3	3

Figure 3.4.3.20

SHEET BRACING DETAILS - METHOD 1 AND 2

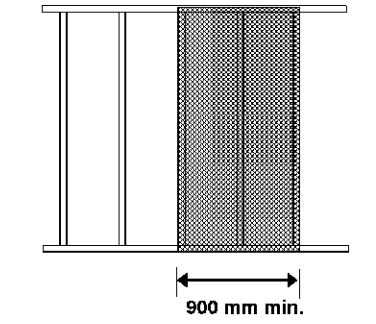

STRESS GRADE	PLYWOOD		HARDBOARD		FIBRE CEMENT BRACING PANEL	
	STUD SPACING (mm)					
	450	600				
F11	4.5	7	RD	5.5 Minimum sheet width 1200 mm	Flat sheet	5
F14	4.0	6	GP	6.4 Minimum sheet width 900 mm	Flat sheet	6
F27	3.0	4.5	-	-	-	-

Note: RD means reduced density hardboard and GP means general purpose hardboard.

BRACING MATERIAL	FIXING FROM SHEET EDGES (mm)	INTERMEDIATE STUDFIXING (mm)	EDGE STUD FIXING (mm)
PLYWOOD	7	300	150
HARDBOARD	10 vertical edge - 20 top and bottom edges	300	100
FIBRE CEMENT BRACING PANEL	12 except 50 from sheet corners	150	100

Notes:

1. Use flat head nails 2.8 mm dia. x 30 mm long min.
2. Panel edges must be supported by studs.
3. Maximum stud spacing 600 mm.

Amdt 3

Figure 3.4.3.21

METAL BRACING DETAILS

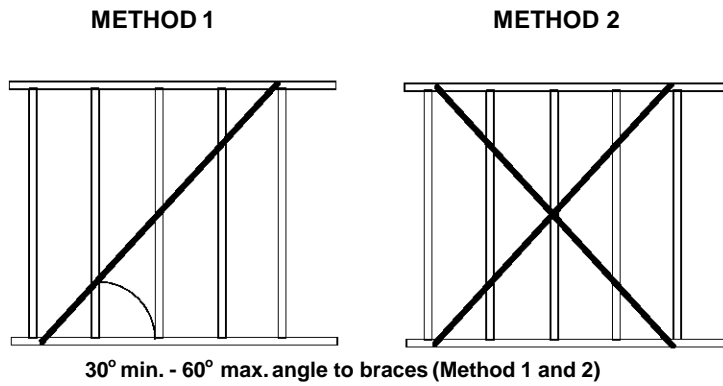

Table a. Metal bracing

METHOD (as per Table 3.4.3.11)	NUMBER OF BRACES PER WALL	FIXING	SPECIAL CONSIDERATIONS
METHOD 1	1	2 each stud; and 3 each plate face	Nails - Flathead 30 mmx28 mm dia.
METHOD 2	2	3 each stud; and 4 each plate face and top and bottom of plate	a. Nails - Flathead 30x3.15 mm dia. b. The brace is returned over the top of the plate and under the bottom plate and nailed

Amdt 3

PART 3.4.4 STRUCTURAL STEEL MEMBERS

Appropriate Performance Requirements:

Where an alternative structural steel member system is proposed to that described in Part 3.4.4, that proposal must comply with *Performance Requirement P2.1* in Section 2.

Explanation of terms

3.4.4 The following terms are used in this Part:

Figure 3.4.4.0

EFFECTIVE MEMBER SPACING FOR STRUCTURAL STEEL BEARERS AND STRUTTING BEAMS

Diagram a. Single spanning rafter or joist

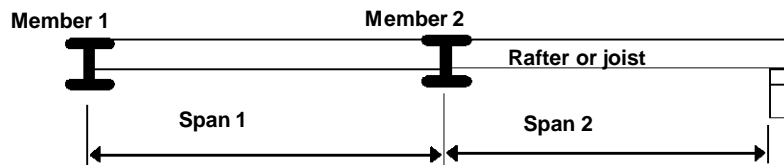

Design member	Member 1	Member 2
Effective member spacing	0.5 x Span 1	0.5 x (Span 1 + Span 2)

Diagram b. Continuous spanning rafter or joist

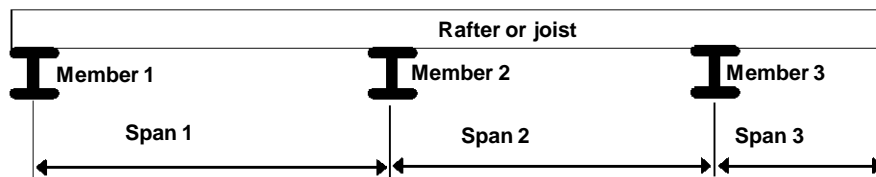

Design member	Member 1	Member 2	Member 3
Effective member spacing	0.4 x Span 1	0.6 x (Span 1 + Span 2)	0.5 x (Span 2) + Span 3

Steel member abbreviations are as follows:

TFB means a tapered flange beam.

UB means a universal beam.

RHS means a rectangular hollow section.

PFC means a parallel flange channel.

TFC means a tapered flange channel.

EA means an equal angle.

UA means an unequal angle.

SHS means a square hollow section.

CHS means a circular hollow section.

A. Acceptable construction manuals

3.4.4.0 *Performance Requirement P2.1* is satisfied for structural steel sections if they are designed and constructed in accordance with one of the following manuals:

- (a) AS 1250 - The use of steel in structures
- (b) AS 4100 - Steel structures

Explanatory information:

Design requirements for other materials used in combination with structural steel members are described in Part 3.4.2, 3.4.3 or Part 3.11 - Structural design.

B. Acceptable construction practice

3.4.4.1 Application

Compliance with this Part satisfies P2.1, provided-

- (a) the building is located in an area with a *design wind speed* of not more than W41; and

Explanatory Information:

1. Information on *design wind speeds* for particular areas may be available from the *appropriate authority*.
2. A map indicating cyclonic regions of Australia is contained in Part 3.10.1.

- (b) the first dimension of steel sections is installed vertically; and
- (c) all loads are uniformly distributed (unless otherwise noted and allowed for); and
- (d) for earthquake design, the building is defined as a design category H1 or H2 domestic structure in accordance with AS 1170.4; and

Explanatory Information:

1. This covers all *sites* except those identified by the site investigation as having soft soil (having a soil profile with more than 5m of soft clay, loose sand, silt or uncontrolled fill) as defined by AS 1170.4.
2. For earthquake design H3, see Part 3.9.2.

- (e) the structural steel member is not subject to snow loads.

3.4.4.2 Structural steel members

- (a) Structural steel members may be used as follows:
- (i) Bearers supporting a timber floor or non-loadbearing stud wall - in accordance with Figure 3.4.4.1.
 - (ii) Strutting beams supporting roof and ceiling loads - in accordance with Figure 3.4.4.2.
 - (iii) Lintels supporting roof, ceiling, frame and timber floor - in accordance with Figure 3.4.4.3.
 - (iv) Columns - in accordance with 3.4.4.3.
- (b) Structural steel members described in this Part must be protected against corrosion in accordance with 3.4.4.4.
- (c) Joists, bearers and lintels must be restrained from lateral movement or twisting along their length by fixing rafters or joists to the top flange of the member so that it prevents that member from moving laterally.
- (d) End supports for joists, bearers and lintels must transfer loads to the footings and have a bearing distance as follows:
- (i) For single spans, the bearing distance must be not less than the width of the member.
 - (ii) For continuous spans, internal bearing must be not less than 2 times the width of the member.

Figure 3.4.4.1

BEARER SUPPORTING A TIMBER FLOOR AND NON-LOADBEARING STUD WALL

Bearer connection examples

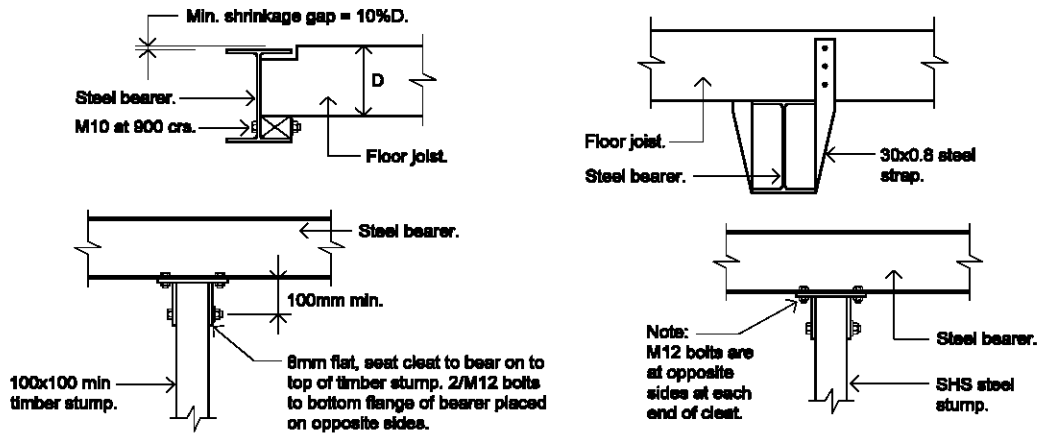

Table a. - Acceptable bearer spans

Steel Section	SINGLE SPAN					CONTINUOUS SPAN				
	<i>Effective Bearer Spacing (m)</i>					<i>Effective Bearer Spacing (m)</i>				
	1.8	2.4	3.0	3.6	4.2	1.8	2.4	3.0	3.6	4.2
	MAXIMUM SPAN OF BEARER (M)					MAXIMUM SPAN OF BEARER (M)				
125TFB	4.1	3.8	3.6	3.4	3.2	4.7	4.3	3.8	3.5	3.2
180UB16.1	5.1	4.7	4.5	4.3	4.1	5.9	5.5	5.2	5.0	4.7
200UB18.2	5.6	5.2	5.0	4.7	4.6	6.5	6.0	5.7	5.5	5.3
250UB25.7	6.8	6.4	6.0	5.8	5.6	7.9	7.4	7.0	6.7	6.4
250x150x9.0 RHS	7.7	7.1	6.7	6.4	6.2	8.8	8.2	7.8	7.4	7.1
250x150x5.0 RHS	6.8	6.3	5.9	5.7	5.5	7.8	7.2	6.8	6.5	6.3
310UB32.0	7.9	7.3	7.0	6.7	6.4	9.1	8.5	8.1	7.7	7.4
125x75x20 RHS	3.1	2.8	2.6	2.5	2.4	4.0	3.7	3.5	3.3	3.1
125x75x30 RHS	3.5	3.2	3.0	2.8	2.7	4.4	4.1	3.9	3.7	3.5
150x50x20 RHS	3.4	3.1	2.8	2.7	2.5	4.2	3.9	3.7	3.5	3.4
150x50x30 RHS	3.7	3.4	3.2	3.0	2.9	4.6	4.3	4.1	3.9	3.7
100TFC	3.2	2.9	2.7	2.6	2.4	3.7	3.2	2.8	2.6	2.4
150PFC	4.8	4.5	4.2	4.0	3.9	5.5	5.1	4.9	4.7	4.5
180PFC	5.4	5.1	4.8	4.6	4.4	6.3	5.9	5.6	5.3	5.1
200PFC	5.9	5.5	5.2	5.0	4.8	6.8	6.3	6.0	5.7	5.50
250PFC	7.2	6.7	6.4	6.1	5.9	8.4	7.8	7.4	7.1	6.8
300PFC	8.1	7.6	7.2	6.9	6.6	9.4	8.8	8.3	8.0	7.7

Notes:

1. Steel is base grade.
2. Load must be evenly distributed along the member.
3. For continuous floor bearers, the variation in span length should not be more than 10%.
4. See 3.4.2.3 for provisions that apply to suspended floors in single storey and ground floor construction of suspended steel floor frames.
5. Effective bearer spacing is a measure of the width of the load area being supported by the member (see Figure 3.4.4.0).

Amdt 3

Figure 3.4.4.2

STRUTTING BEAM SUPPORTING A ROOF AND CEILING

Strutting beam application

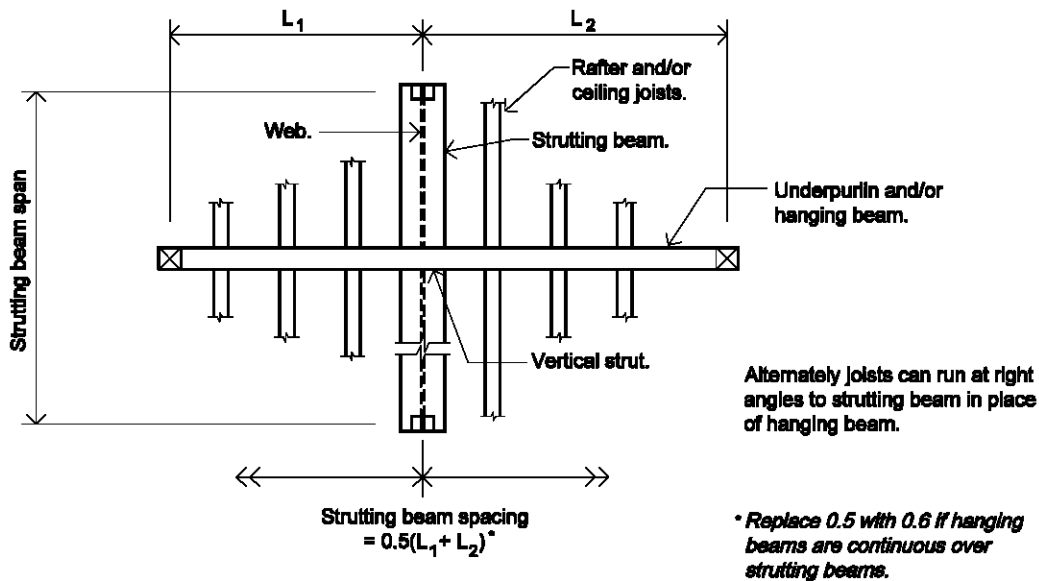

Table a. - Acceptable strutting beam spans

Steel Section	STEEL SHEET ROOF					TILED ROOF				
	Strutting Beam Spacing (m)					Strutting Beam Spacing (m)				
	1.8	2.4	3.0	3.6	4.2	1.8	2.4	3.0	3.6	4.2
	MAXIMUM SPAN OF STRUTTING BEAM (M)					MAXIMUM SPAN OF STRUTTING BEAM (M)				
125TFB	5.7	5.4	5.1	4.9	4.6	4.9	4.6	4.4	4.2	4.1
150UB14.0	6.4	6.0	5.7	5.4	5.1	5.5	5.2	4.9	4.7	4.5
200UB18.2	7.9	7.4	7.1	6.8	6.5	6.9	6.4	6.1	5.8	5.6
250UB31.4	10.0	9.4	9.0	8.7	8.4	8.8	8.2	7.8	7.5	7.2
310UB46.2	11.9	11.3	10.8	10.5	10.1	10.6	10.0	9.5	9.1	8.8
100TFC	4.6	4.4	4.2	3.9	3.7	4.0	3.7	3.6	3.4	3.2
150PFC	6.7	6.3	6.0	5.8	5.6	5.8	5.5	5.2	5.0	4.8
200PFC	8.2	7.7	7.4	7.1	6.8	7.2	6.7	6.4	6.1	5.9
250PFC	10.0	9.4	9.0	8.7	8.4	8.8	8.2	7.8	7.5	7.3
300PFC	11.1	10.5	10.1	9.7	9.4	9.8	9.3	8.8	8.4	8.2

Note:

1. If point load applied, then it should be located within the middle third of the strutting beam span.
2. Top and bottom flanges of strutting beam must be laterally restrained at the loading point.
3. Strutting beam must be tied down at the support points, in the case of steel sheet roofs.
4. Steel is base grade.

Amdt 3

Figure 3.4.4.3

LINTELS SUPPORTING ROOF, FRAMES AND TIMBER FLOORS

Lintels supporting roof and floors

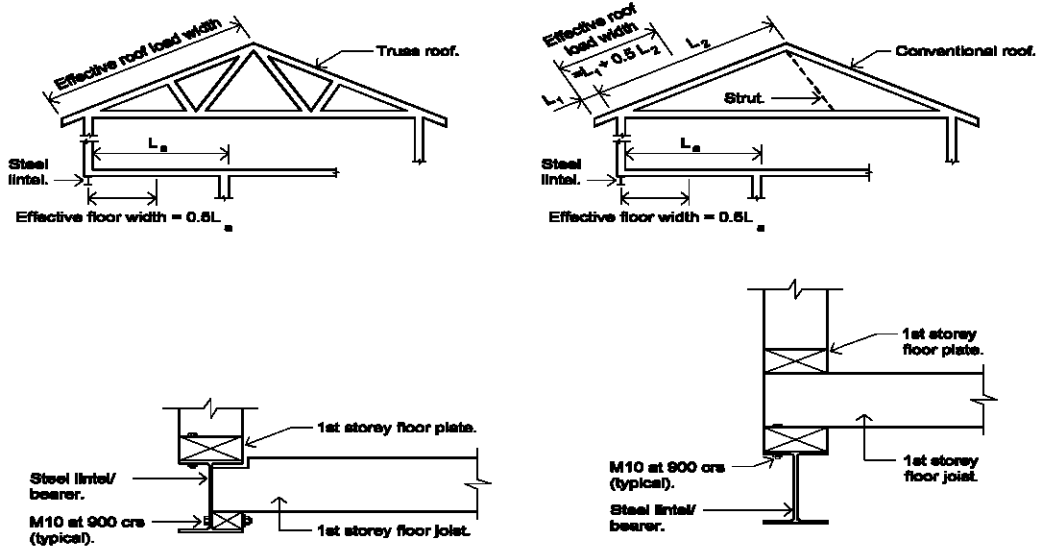

Table a. - Acceptable spans for lintels

Steel Section	STEEL SHEET ROOF					TILED ROOF				
	Effective Load Width (m)					Effective Load Width (m)				
	1.8	2.4	3.0	3.6	4.2	1.8	2.4	3.0	3.6	4.2
	MAXIMUM SPAN OF LINTEL (M)					MAXIMUM SPAN OF LINTEL (M)				
125TFB	3.7	3.4	3.2	3.0	2.8	3.6	3.3	3.0	2.9	2.7
150UB14.0	4.1	3.9	3.7	3.5	3.3	4.0	3.7	3.5	3.3	3.2
200UB25.4	5.6	5.3	5.0	4.8	4.7	5.4	5.1	4.8	4.6	4.5
250UB31.4	6.6	6.2	5.9	5.7	5.5	6.3	6.0	5.7	5.4	5.2
100TFC	2.8	2.6	2.4	2.3	2.1	2.7	2.5	2.3	2.1	2.0
150PFC	4.4	4.1	3.9	3.7	3.6	4.2	3.9	3.7	3.6	3.4
200PFC	5.4	5.0	4.8	4.6	4.4	5.1	4.8	4.6	4.4	4.2
250PFC	6.6	6.2	5.9	5.7	5.5	6.3	6.0	5.7	5.4	5.3
75x75x5EA	1.3	1.2	1.1	-	-	1.3	1.1	-	-	-
90x90x6EA	1.9	1.6	1.5	1.3	1.2	1.7	1.5	1.4	1.3	1.2
100x100x6EA	2.0	1.8	1.6	1.5	1.4	1.9	1.7	1.5	1.4	1.3
125x75x6UA	2.3	2.0	1.8	1.7	1.5	2.2	1.9	1.7	1.6	1.4
150x100x10UA	3.9	3.6	3.2	2.9	2.7	3.7	3.3	3.0	2.8	2.6

Note:

1. Top flange of lintel must be laterally restrained at the loading points.
2. Load must be evenly distributed along the member, eg joists.
3. Angle lintels - first dimension corresponds to vertical leg, eg 100x75x6UA, 100 mm leg is vertical.
4. For lintels supporting masonry walls, see Part 3.3.3.

Amdt 3

3.4.4.3 Columns

Columns may support the area provided for in Table 3.4.4.1 provided-

- (a) the effective height of the column is determined in accordance with Figure 3.4.4.4; and
- (b) the *floor area* to be supported is determined in accordance with Figure 3.4.4.5; and
- (c) the load eccentricity between the centre of the column and the applied vertical loading complies with Figure 3.4.4.6.

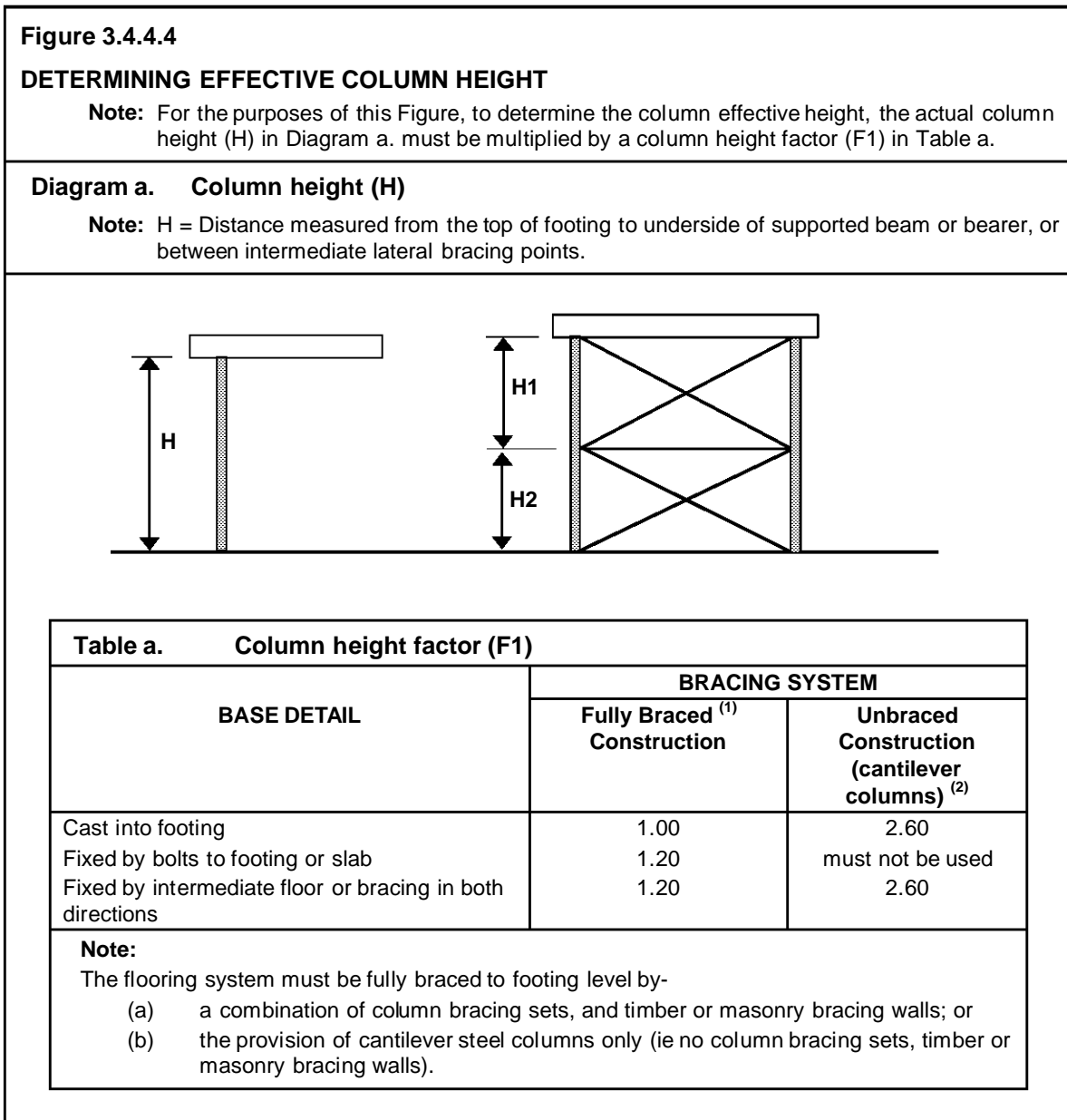

Amdt 3

Figure 3.4.4.5

DETERMINING FLOOR AREA SUPPORTED

Note:

The total area supported depends on the position of the column in the structure as shown in Diagram a. To calculate the correct area supported by a column, match the column's position with those shown in Diagram a. which shows a plan view of a floor and then calculate the total area supported from Table a.

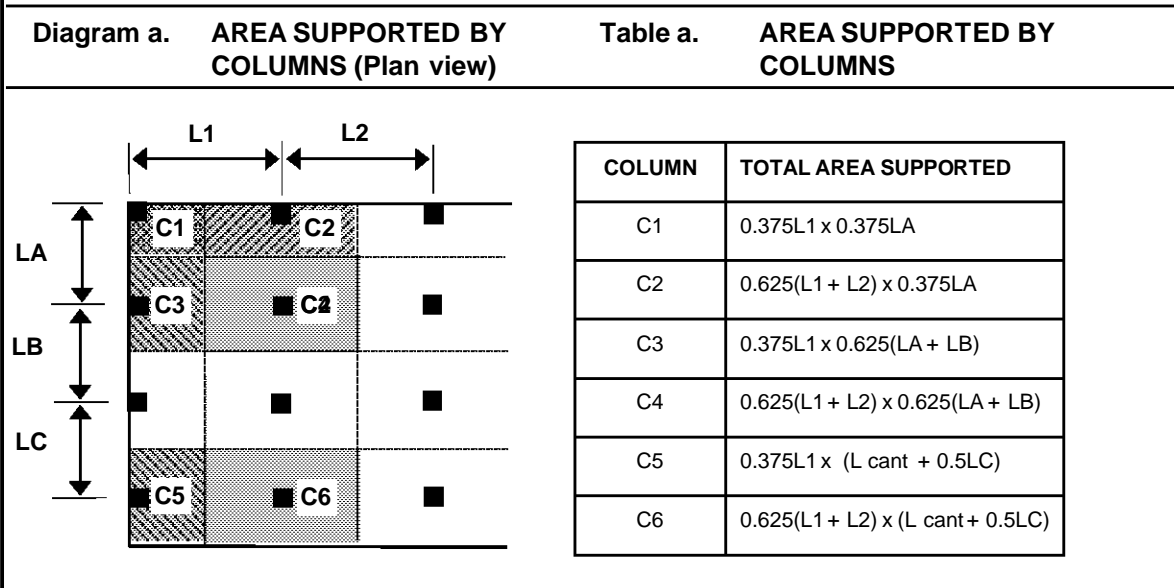

Amdt 3

Figure 3.4.4.6

ACCEPTABLE LOAD ECCENTRICITY FOR COLUMNS

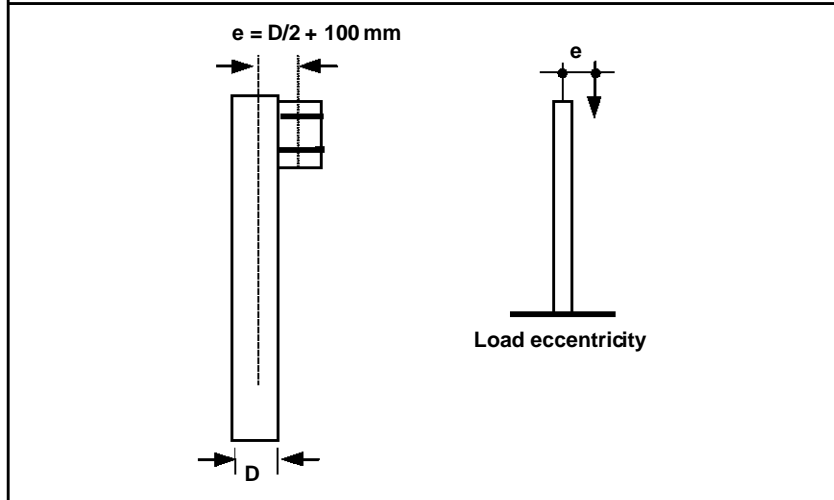

**Table
3.4.4.1
Amdt No. 2**

Table 3.4.4.1						
COLUMNS - SUPPORTING TIMBER FLOOR ONLY						
Note: Tabulated values are the columns sections to be used.						
COLUMN EFFECTIVE HEIGHT (mm)	FLOOR AREA SUPPORTED (m²)					
	5	10	15	20	25	
CHS C250	600	60.3 x 3.6	88.9 x 4.0	101.6 x 5.0	114.3 x 5.4	139.7 x 5.0
	1200	60.3 x 4.5	88.9 x 4.0	101.6 x 5.0	114.3 x 5.4	139.7 x 5.0
	1800	60.3 x 4.5	88.9 x 4.0	101.6 x 5.0	114.3 x 5.4	139.7 x 5.0
	2400	60.3 x 4.5	88.9 x 4.0	101.6 x 5.0	114.3 x 5.4	139.7 x 5.0
	3600	76.1 x 3.6	101.6 x 4.0	114.3 x 4.5	139.7 x 5.0	139.7 x 5.0
CHS C350	600	60.3 x 2.9	88.9 x 2.6	101.6 x 3.2	114.3 x 3.6	139.7 x 3.5
	1200	60.3 x 2.9	88.9 x 2.6	101.6 x 3.2	114.3 x 3.6	139.7 x 3.5
	1800	60.3 x 2.9	101.6 x 2.6	114.3 x 3.2	114.3 x 3.6	139.7 x 3.5
	2400	76.1 x 2.3	101.6 x 2.6	114.3 x 3.2	139.7 x 3.0	139.7 x 3.5
	3600	88.9 x 2.6	101.6 x 2.6	114.3 x 3.2	139.7 x 3.0	165.1 x 3.0
SHS C350	600	50 x 50 x 2.5	75 x 75 x 2.5	75 x 75 x 4.0	100 x 100 x 4.0	100 x 100 x 4.0
	1200	65 x 65 x 2.0	75 x 75 x 2.5	75 x 75 x 4.0	100 x 100 x 4.0	100 x 100 x 4.0
	1800	65 x 65 x 2.0	75 x 75 x 3.0	100 x 100 x 3.0	100 x 100 x 4.0	100 x 100 x 4.0
	2400	65 x 65 x 2.0	75 x 75 x 3.0	100 x 100 x 3.0	100 x 100 x 4.0	100 x 100 x 5.0
	3600	65 x 65 x 2.5	75 x 75 x 4.0	100 x 100 x 3.0	100 x 100 x 4.0	100 x 100 x 5.0
SHS C450	600	50 x 50 x 2.0	65 x 65 x 2.5	75 x 75 x 3.0	100 x 100 x 2.8	100 x 100 x 3.3
	1200	50 x 50 x 2.0	65 x 65 x 2.5	75 x 75 x 3.0	100 x 100 x 3.0	100 x 100 x 3.3
	1800	50 x 50 x 2.3	75 x 75 x 2.3	75 x 75 x 3.3	100 x 100 x 3.0	100 x 100 x 3.8
	2400	65 x 65 x 2.0	75 x 75 x 2.5	75 x 75 x 3.5	100 x 100 x 3.0	100 x 100 x 3.8
	3600	65 x 65 x 2.3	100 x 100 x 2.0	100 x 100 x 2.8	100 x 100 x 3.8	100 x 100 x 4.0
COLUMNS - SUPPORTING TILE ROOF ONLY						
COLUMN EFFECTIVE HEIGHT (mm)	ROOF AREA SUPPORTED (m²)					
	5	10	15	20	25	
CHS C250	600	60.3 x 3.6	60.3 x 3.6	76.1 x 3.6	76.1 x 4.5	88.9 x 4.0
	1200	60.3 x 3.6	60.3 x 3.6	76.1 x 3.6	76.1 x 4.5	101.6 x 4.0
	1800	60.3 x 3.6	60.3 x 3.6	76.1 x 3.6	76.1 x 4.5	101.6 x 4.0
	2400	60.3 x 3.6	60.3 x 4.5	76.1 x 3.6	88.9 x 4.0	101.6 x 4.0
	3600	60.3 x 3.6	76.1 x 3.6	76.1 x 4.5	88.9 x 4.0	101.6 x 4.0
CHS C350	600	60.3 x 2.3	60.3 x 2.3	76.1 x 2.3	88.9 x 2.6	101.6 x 2.6
	1200	60.3 x 2.3	60.3 x 2.9	76.1 x 2.3	88.9 x 2.6	101.6 x 2.6
	1800	60.3 x 2.3	60.3 x 2.9	88.9 x 2.6	88.9 x 2.6	101.6 x 2.6
	2400	60.3 x 2.3	76.1 x 2.3	88.9 x 2.6	88.9 x 2.6	101.6 x 2.6
	3600	60.3 x 2.3	76.1 x 2.3	88.9 x 2.6	101 x 2.6	101.6 x 3.2
SHS C350	600	50 x 50 x 2.0	50 x 50 x 2.5	65 x 65 x 2.5	75 x 75 x 2.5	75 x 75 x 3.0
	1200	50 x 50 x 2.0	50 x 50 x 2.5	65 x 65 x 2.5	75 x 75 x 2.5	75 x 75 x 3.0
	1800	50 x 50 x 2.0	65 x 65 x 2.0	65 x 65 x 2.5	75 x 75 x 2.5	75 x 75 x 3.0
	2400	50 x 50 x 2.0	65 x 65 x 2.0	65 x 65 x 2.5	75 x 75 x 2.5	75 x 75 x 4.0
	3600	50 x 50 x 2.5	65 x 65 x 2.5	75 x 75 x 2.5	75 x 75 x 3.0	75 x 75 x 4.0
SHS C450	600	50 x 50 x 1.6	50 x 50 x 2.0	65 x 65 x 2.0	65 x 65 x 2.3	65 x 65 x 2.8
	1200	50 x 50 x 1.6	50 x 50 x 2.0	65 x 65 x 2.0	65 x 65 x 2.3	65 x 65 x 2.8
	1800	50 x 50 x 1.6	65 x 65 x 1.6	65 x 65 x 2.0	65 x 65 x 2.5	75 x 75 x 2.5
	2400	50 x 50 x 1.6	50 x 50 x 2.5	65 x 65 x 2.3	75 x 75 x 2.3	75 x 75 x 2.8
	3600	50 x 50 x 2.0	65 x 65 x 2.0	75 x 75 x 2.3	100 x 100 x 2.0	100 x 100 x 2.3

Amdt 3

3.4.4.4 Corrosion protection

Structural steel members must be protected against corrosion in accordance with Table 3.4.4.2.

Explanatory Information:

Expl. Info.
Amdt No. 3

1. For internal steelwork, where the steel is situated in a basically permanently dry location, the steel normally needs little or no protection.
2. Beams over kitchens and bathrooms and the like, where moisture may be present may need increased protection.
3. For applications outside the scope of this table, seek specialist advice.

Table
3.4.4.2
Amdt No. 3

Amdt 3

Table 3.4.4.2 PROTECTIVE COATINGS FOR STEELWORK			
ENVIRONMENT	LOCATION	MINIMUM PROTECTIVE COATING	
		General structural steel members	Lintels in masonry
MODERATE More than 1 km from coast or non-heavy industrial areas	INTERNAL	No protection required	
	EXTERNAL	Option 1. 2 coats alkyd primer; or Option 2. 2 coats alkyd gloss Option 3. Hot dip galvanise 300 g/m ² min Option 4. Hot dip galvanise 100 g/m ² min plus - (a) 1 coat solvent based vinyl primer; or (b) 1 coat vinyl gloss or alkyd.	
SEVERE Within 1 km from coast or heavy industrial areas	INTERNAL	Option 1. 2 coats alkyd primer Option 2. 2 coats alkyd gloss	
	EXTERNAL	Option 1. Inorganic zinc primer plus 2 coats vinyl gloss finishing coats Option 2. Hot dip galvanise 300g/m ² Option 3. Hot dip galvanise 100 g/m ² min plus - (a) 2 coats solvent based vinyl primer; or (b) 2 coats vinyl gloss or alkyd.	Hot dip galvanise 600 g/m ²
Notes: 1. Heavy industrial areas means industrial environments around major industrial complexes. There are only a few such regions in Australia, examples of which occur around PortPirie and Newcastle. 2. The outer leaf and cavity of an external masonry wall of a building, including walls under open carports are considered to be external environments. A part of an internal leaf of an external masonry wall which is located in the roof space is considered to be in an internal environment. 3. Where a paint finish is applied the surface of the steel work must be hand or power tool cleaned to remove any rust immediately prior to painting. 4. All zinc coatings (including inorganic zinc) require a barrier coat to stop conventional domestic enamels from peeling. 5. Refer to the paint manufacturer where decorative finishes are required on top of the minimum coating specified in the table for protection of the steel against corrosion.			

PART **3.5**

Amdt 3

ROOF AND WALL CLADDING

3.5.1 Roof Cladding

3.5.2 Gutters and Downpipes

3.5.3 Wall Cladding

PART 3.5 CONTENTS

	Page
3.5.1 Roof cladding	13,021
3.5.1.0 Acceptable construction manuals	
3.5.1.1 Application	
3.5.1.2 Roof tiling	
3.5.1.3 Metal sheet roofing	
3.5.2 Gutters and downpipes	13,301
3.5.2.1 Application	
3.5.2.2 Materials	
3.5.2.3 Selection of guttering	
3.5.2.4 Installation of gutters	
3.5.2.5 Downpipes - size and installation	
3.5.3 Wall cladding	13,501
3.5.3.1 Application	
3.5.3.2 Timber weatherboard cladding	
3.5.3.3 Fibre cement planks and weatherboard cladding	
3.5.3.4 Sheet wall cladding	
3.5.3.5 Eaves and soffit lining	
3.5.3.6 Flashings to wall openings	

Explanatory Information:

These provisions relate to installing systems to waterproof roofs, walls and wall openings.

It should be noted that other construction methods may be used to achieve the same results as specified in this Part provided they comply with the appropriate *Performance Requirement*.

PART 3.5.1 ROOF CLADDING

Appropriate Performance Requirements

Where an alternative roof cladding is proposed to that described in Part 3.5.1, that proposal must comply with the structural *Performance Requirements* P2.1 and P2.2.2 in Section 2.

A. Acceptable construction manual

3.5.1.0 Performance Requirements P2.1 and P2.2.2 are satisfied for roof cladding on Class 1 and 10 buildings if it complies with one of the following manuals:

- (a) AS 2049 - Roof tiles.
- (b) AS 2050 - Fixing of roofing tiles.
- (c) AS 1562.1 - Design and installation of metal sheet roofing.
- (d) AS/NZS 4256 Pts 1, 2, 3 and 5; and AS 1562.3 - Plastic sheet roofing.
- (e) AS 1639 - The design and installation of corrugated fibre reinforced cement roofing and wall cladding.
- (f) ASTM D3018-90 - Asphalt shingles.
- (g) AS/NZS 4200 - Installation of pliable membrane and underlay.

3.5.1.0
(c) and (d)
Amdt No. 3

B. Acceptable construction practice

3.5.1.1 Application

Compliance with this Part satisfies *Performance Requirements* P2.1 and P2.2.2 for roof cladding, provided-

- (a) the building is located in an area with a *design wind speed* of not more than W41; and

Explanatory Information:

1. Information on *design wind speeds* for particular areas may be available from the *appropriate authority*.
2. A map indicating cyclonic regions of Australia is contained in Part 3.10.1.

- (b) roof tiles are installed in accordance with 3.5.1.2; and
- (c) sheet roofing is installed in accordance with 3.5.1.3.

3.5.1.2 Roof tiling

- (a) Roof tiles, complying with AS 2049, must be installed, fixed and flashed in accordance with the relevant provisions of this Part.
- (b) Roof tiles on roofs with a pitch not more than 35 degrees must be fixed in accordance with Figure 3.5.1.1.
- (c) Fixings for roof battens and batten sizes must comply with Part 3.4.3.
- (d) All tiled roof flashings, ridge and hip tiles must be installed in accordance with Figure 3.5.1.2.

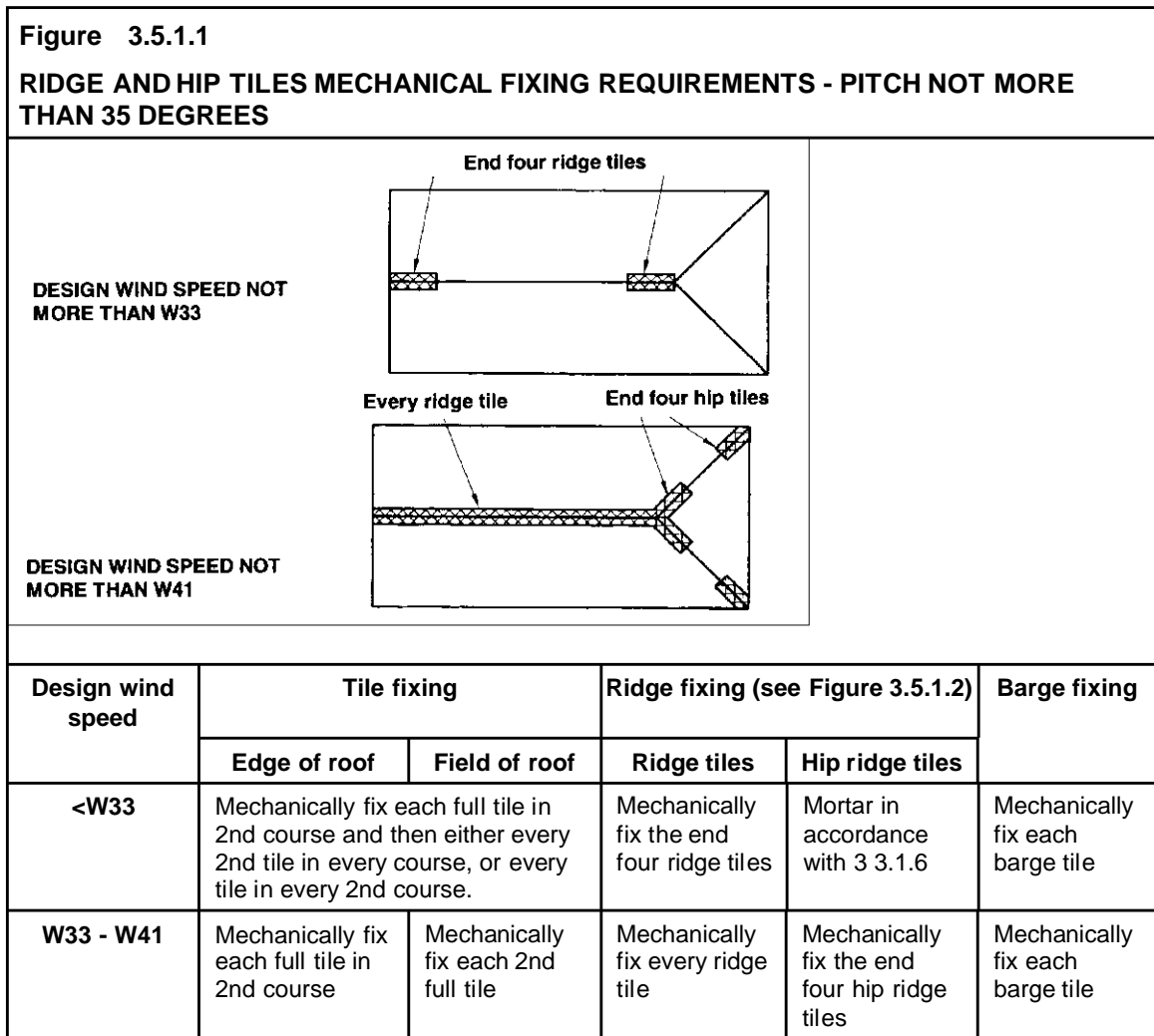

Amdt 3

Figure 3.5.1.2

TILED ROOF FLASHING AND OTHER DETAILS

a. Mechanical fixing-ridge clip (Also see Figure 3.5.1.1)

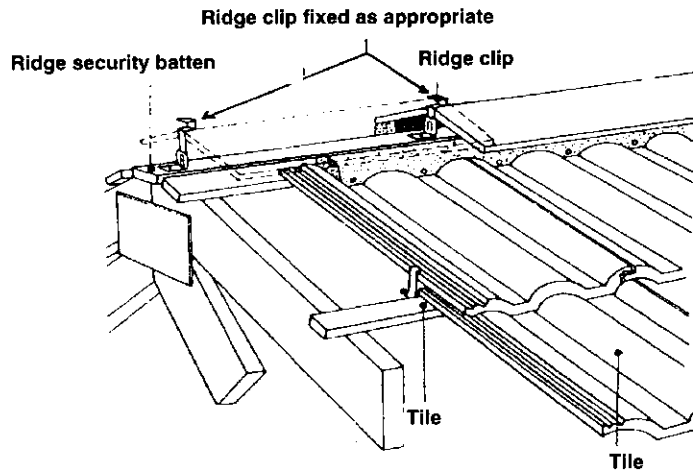

b. Dry valley

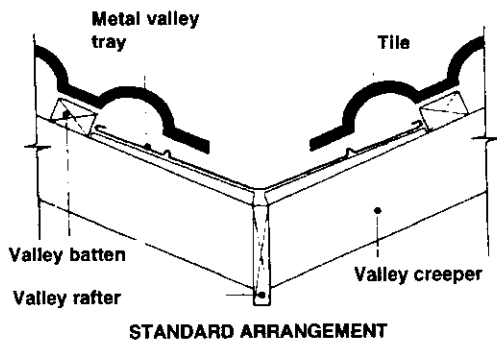

c. Bedded and pointed valley

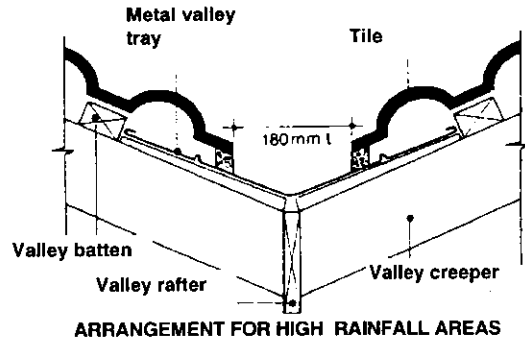

d. Fixing of hip tiles

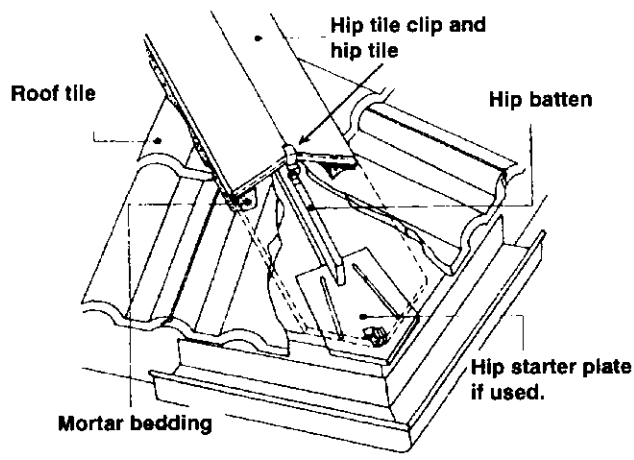

3.5.1.3 Metal sheet roofing

- (a) The design and installation of metal sheet roofing must comply with the relevant provisions of this Part.
- (b) Metal sheet roofing must be protected from corrosion in accordance with Table 3.5.1.1.

Table 3.5.1.1		
ACCEPTABLE CORROSION PROTECTION FOR SHEET ROOFING		
ROOF ENVIRONMENT	METAL COATING IN ACCORDANCE WITH AS 1397	
	Metallic coated steel	Metallic and organic coating
Moderate Inland areas with no salt or heavy industry pollution	(a) Z450 galvanised (b) AZ150 zinc/aluminium	(a) Z275 galvanised (b) AZ150 zinc/aluminium
Severe Close to the sea with frequent onshore winds and in local areas with heavy industrial pollution	AZ200	Not suitable

- (c) Where different metals are used in a roofing system, including cladding, flashings, fasteners, downpipes etc, they must be compatible with each other (to prevent corrosion due to an adverse chemical reaction) as described in Table 3.5.1.2 and-
 - (i) no lead materials can be used upstream from zinc- aluminium coated materials; and
 - (ii) no copper materials can be used upstream from galvanised coated materials.
- (d) Metal sheet roofing must-
 - (i) be fixed at spacings in accordance with Figure 3.5.1.5; and
 - (ii) use fastening devices made of a compatible metal to the roofing in accordance with 3.5.1.3 (c); and
 - (iii) when using both clipped and pierced fastening systems-

Amdt 3

- (A) employ an anti-capillary feature in the side lap of the sheet, to prevent capillary action drawing moisture into the lap and allowing the lap to drain (achieved by not over tightening the sheet fixings, see Figure 3.5.1.3); and
- (B) wherever possible have the sheets laid so that the side lap is facing away from prevailing weather.

Table 3.5.1.2								
ACCEPTABILITY OF CONTACT BETWEEN DIFFERENT ROOFING MATERIALS								
Note: 1. No - means the metal cannot be used in association with the other metal. 2. Yes - means the metal can be used in association with the other metal.								
CLADDING MATERIAL	ACCESSORY OR FASTENER MATERIAL							
	Stainless steel	Zinc-coated steel and Zinc		Zinc/Aluminium coated steel		Lead		
	Atmosphere Classification (S = Severe and M = Moderate environment as Per Table 3.5.1.1)							
	S	M	S	M	S	M	S	M
Copper and copper alloys	No	Yes	No	No	No	No	No	Yes
Stainless steel (300 series)	Yes	Yes	No	No	No	No	No	Yes
Zinc-coated steel and zinc	No	Yes	Yes	Yes	Yes	Yes	No	Yes
Zinc/aluminium coated steel	No	Yes	Yes	Yes	Yes	Yes	No	No
Lead	Yes	Yes	No	Yes	No	No	Yes	Yes

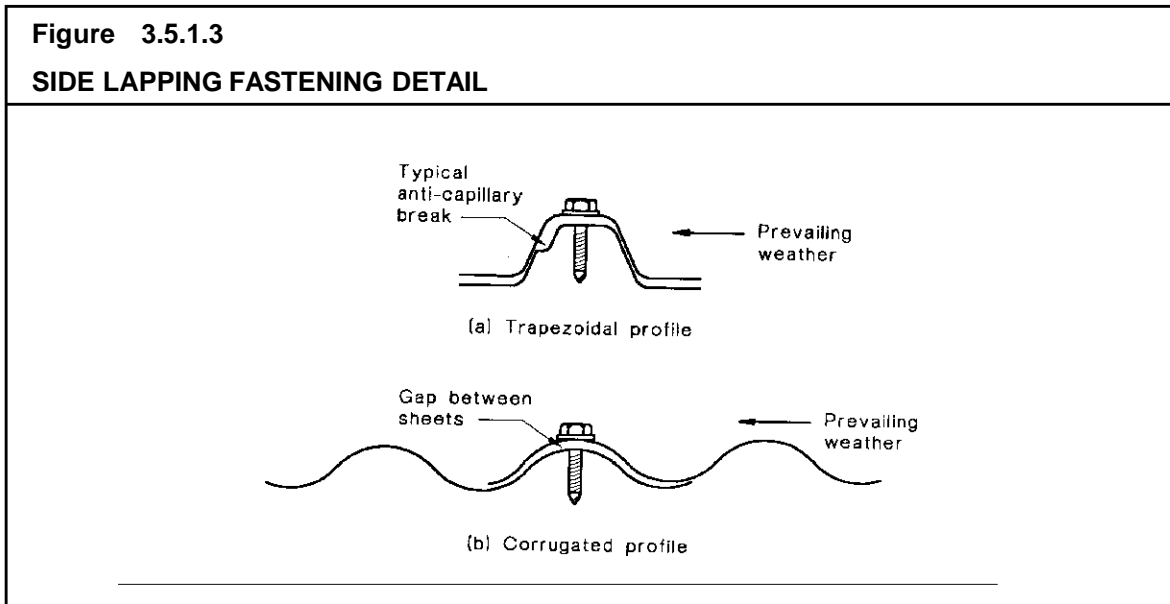

Amdt 3

- (e) Sheets must be-
- (i) laid wherever possible using complete lengths from ridge to eaves; or
 - (ii) where a complete length cannot be laid-
 - (A) each run must be laid in specific sequence (see Figure 3.5.1.4) from bottom to top before moving on to the next run; and
 - (B) the distance for end lapping where sheets meet is-
 - (aa) for roof slopes between 5-15 degrees (1:12 - 1:4) - a lap of 200 mm; and
 - (bb) for roof slopes above 15 degrees (1:4) - a lap of 150 mm; and
 - (iii) stop ended (ie each valley turned up 60 degrees) at the ridge line of each length.

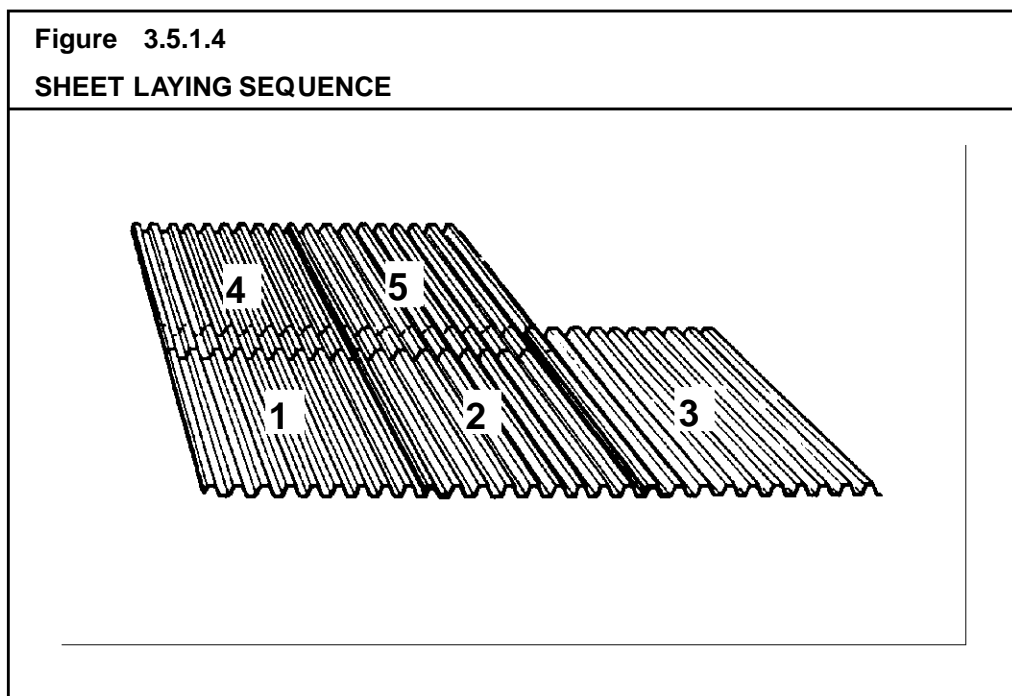

- (f) Metal sheet roofing must comply with the pitch and span limitations between roofing supports as shown in Figure 3.5.1.5.

Figure 3.5.1.5

MAXIMUM SPAN AND FIXING FOR METAL SHEET ROOFING

Note: The end span of some trapezoidal roofing systems may need to be reduced to 1.5 m (see proprietary information).

Diagram a. Typical profiles - Pitch is appropriate for a sheet run up to 25 m in length

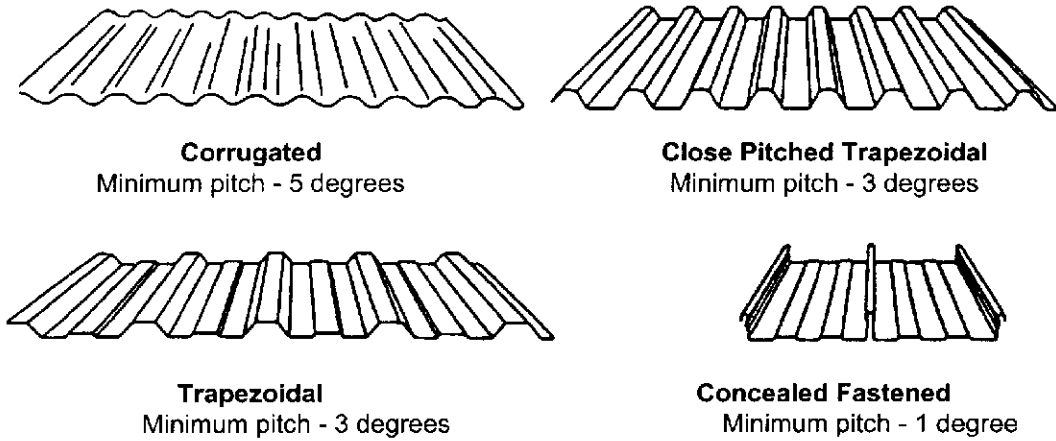
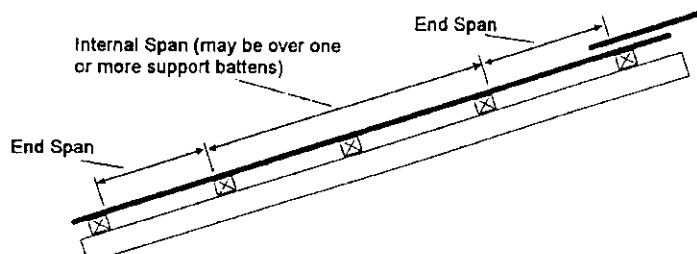

Diagram b. End and internal roof spans



Note: End span is also the end of sheets where they overlap with an adjoining sheet.

PROFILE	BASE METAL THICKNESS (mm)	END SPAN (mm)	INTERNAL SPAN (mm)	FIXING (crest fastening)	
				END SPAN	INTERNAL SPANS
Corrugated	0.42	950	1200	Every second rib	Every third rib
Close pitched trapezoidal	0.42	1900 *	2400	Every rib	Every second rib
Trapezoidal	0.42	1350	1700	Every rib	
Concealed Fasteners	0.48	1800	2100	Every rib	

Amdt 3

- (g) Sheet metal roof flashings and cappings must comply with the following:
 - (i) Roof flashings and cappings must be purpose made, machine-folded sheet metal sections of materials compatible with all up and downstream metal roof covering materials in accordance with 3.5.1.3(c).
 - (ii) The type of fasteners for flashings and cappings must comply with 3.5.1.3(d).
 - (iii) The frequency of fastener fixings for transverse flashings and cappings must comply with Table 3.5.1.3.

Table 3.5.1.3 FASTENER FREQUENCY FOR TRANSVERSE FLASHINGS AND CAPPINGS		
ROOF TYPE	FIXING FREQUENCY	FASTENER TYPE
Concealed fastened roofs	Every rib	Rivets and self drilling screws
Pierced fastened roofs	Every 2nd Rib	Self drilling screws or rivets
Corrugated roofs	Every 4th Rib	Self drilling screws or rivets

- (iv) Joints in flashing and cappings must be not less than 25 mm, fastened at intervals of not more than 40 mm and lapped in the direction of the fall of the roof.
- (v) Wall and step flashings must be fastened into masonry walls with galvanised or zinc/aluminium sheet metal wedges at each end of each length and at intermittent intervals of not more than 500 mm and must overlap by not less than 50 mm in the direction of flow.
- (vi) Lead flashings must not be used with prepainted steel or zinc/aluminium steel or on any roof if the roof is part of a potable (drinking) water catchment area.
- (vii) Anti capillary breaks must be installed in accordance with Figure 3.5.1.6 and be-
 - (A) for flat surfaces - 10 mm/30 degree fold; and
 - (B) all other surfaces - 10 mm/90 degree or 135 degree fold.

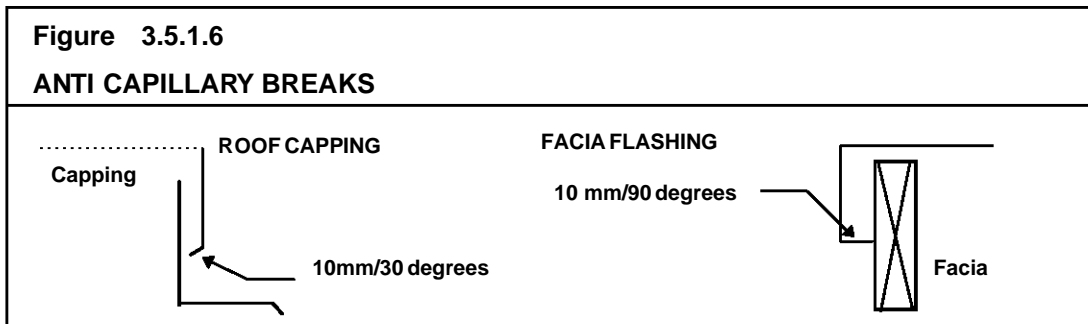

Amdt 3

(viii) Acceptable flashing configurations are shown in Figure 3.5.1.7.

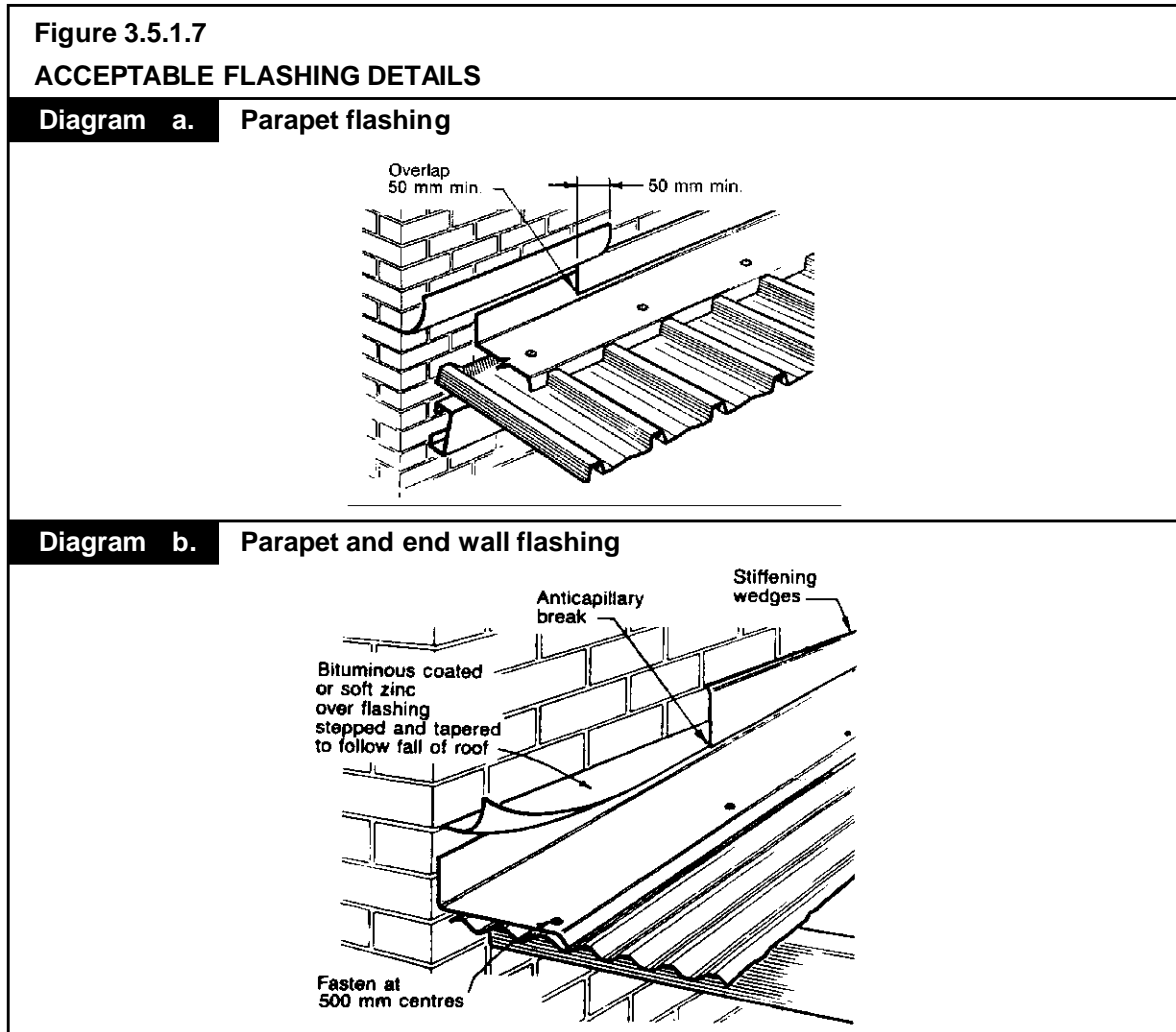

- (h) Flashing of penetrations must comply with the following::
- (i) Collar flashings must permit the total drainage of the area above the penetration.
 - (ii) On completion of installation, the roof structure must be restored to its original strength by installing roof trimmers and soaker supports as necessary.
 - (iii) The type of fasteners for flashings and cappings must comply with 3.5.1.3(d).
 - (vi) Lead flashings must not be used with prepainted steel or zinc/aluminium steel or on any roof if the roof is part of a potable water catchment area.
 - (v) Acceptable flashings for roof penetrations are shown in Figure 3.5.1.8.
 - (vi) Clearance for heating appliance roof support members must be in accordance with Part 3.7.3.

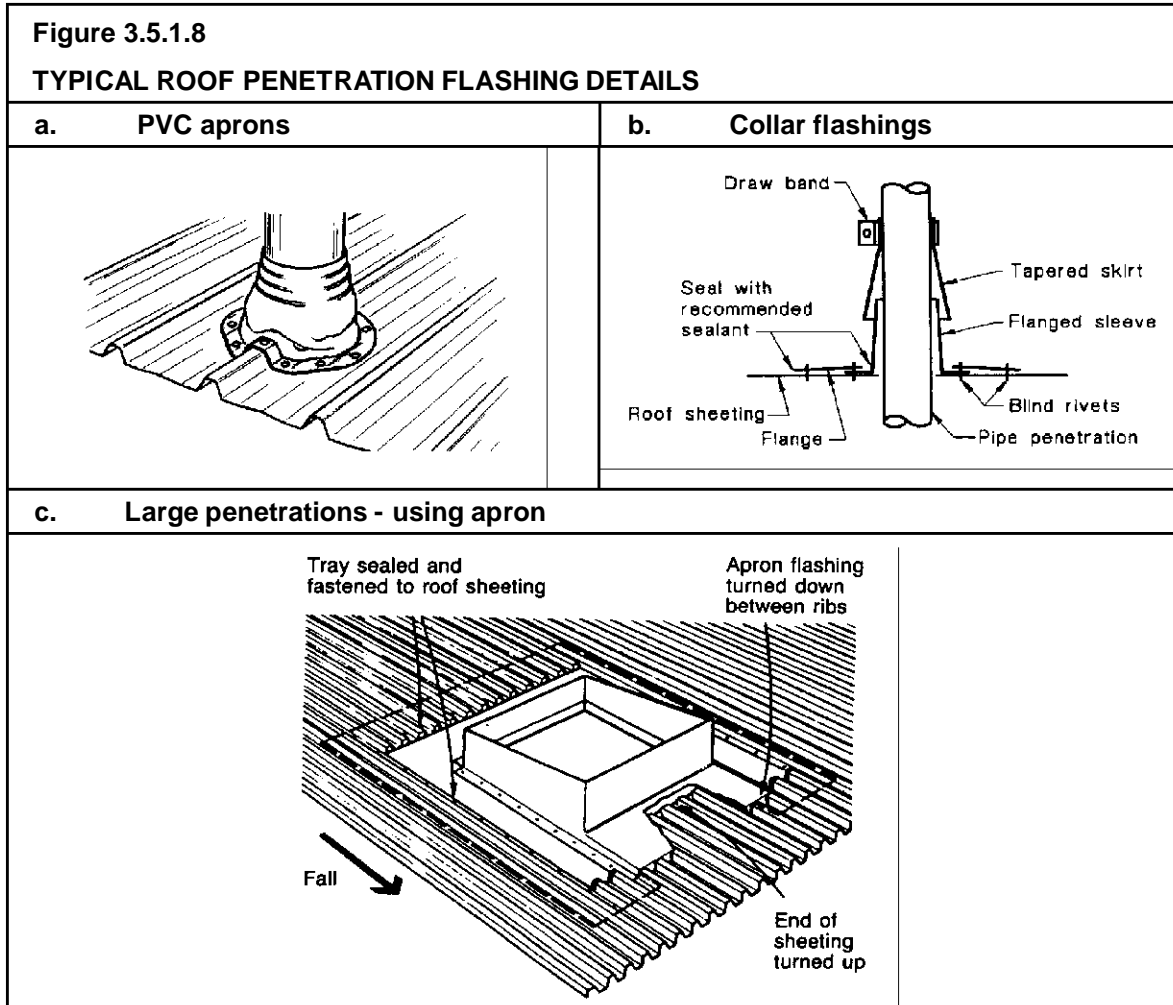

Amdt 3

PART 3.5.2 GUTTERS AND DOWNPIPES

Appropriate *Performance Requirements*

Where an alternative gutter and downpipe system is proposed to that described in Part 3.5.2, that proposal must comply with *Performance Requirement P2.2.1* in Section 2.

A	Acceptable construction manual
----------	---------------------------------------

3.5.2.0 Performance Requirement P2.2.1 is satisfied for gutters and downpipes if they are designed and constructed in accordance with AS/NZS 3500.3.2 - Stormwater drainage.

3.5.2.0
Amdt No. 3

B.	Acceptable construction practice
-----------	---

3.5.2.1 Application

Compliance with this Part satisfies *Performance Requirement P2.2.1* for gutters and downpipes provided-

- (a) the roof drainage system is connected to a stormwater drainage system that complies with Part 3.1.2; and
- (b) the roof drainage system is designed so that any overflow during heavy rain periods is prevented from flowing back into the building.

Explanatory Information:

1. The requirement to install drainage systems from roofs and sub-soil drains should be confirmed with the *appropriate authority*. These provisions need only be applied when drainage systems are necessary.
2. Information on drainage requirements outside the allotment may be available from the *appropriate authority*.

3.5.2.2 Materials

Gutters, downpipes and flashings must be manufactured in accordance with-

- (a) AS 2179 for metal; and
- (b) AS 1273 for UPVC components; and
- (c) be compatible with all upstream roofing materials in accordance with 3.5.1.3(c).

3.5.2.3 Selection of guttering

The size of guttering must-

- (a) be in accordance with Table 3.5.2.2; and
- (b) be suitable to remove rainwater falling at the appropriate rainfall intensity listed in Table 3.5.2.1 as follows:
 - (i) For eaves gutters - 20 year *average recurrence interval*; or
 - (ii) For internal box and valley gutters - 100 year *average recurrence interval*.

3.5.2.4 Installation of gutters

- (a) Gutters must be installed with a fall of not less than-
 - (i) 1:500 for eaves gutters, unless fixed to metal facias; and
 - (ii) 1:100 for box gutters.
- (b) Eaves gutters must be supported by brackets securely fixed at stop ends and at not more than 1.2 m centres.

3.5.2.4(c)
Amdt No. 2

- (c) Valley gutters on a roof with a pitch-
 - (i) more than 12.5 degrees - must have width of not less than 400 mm and be wide enough to allow the roof covering to overhang not less than 150 mm each side of the gutter; or
 - (ii) not more than 12.5 degrees - must be designed as a box gutter.

3.5.2.5 Downpipes - size and installation

- (a) Downpipes must be securely fixed to walls.
- (b) The spacing between downpipes must not be more than 12 m.
- (c) Downpipes must be fixed as close as possible to valley gutters and, if the downpipe is more than 1.2 m from a valley, provision for overflow must be made.

3.5.2.5(d)
Amdt No. 2

- (d) Where high-fronted gutters are installed, provision must be made to avoid any overflow from flowing back into the roof or building structure by installing slotted gutters or the like.
- (e) Downpipes must-
 - (i) be compatible with other roofing materials used in the roofing system in accordance with 3.5.1.3 (c); and
 - (ii) be selected in accordance with appropriate eaves gutter section as shown in Table 3.5.2.2.

Table 3.5.2.1					
RAINFALL INTENSITIES					
Locality	5 minute rainfall intensity (mm/h)		Locality	5 minute rainfall intensity (mm/h)	
	<i>Average recurrence interval, once in -</i>			<i>Average recurrence interval, once in -</i>	
	20 years	100 years		20 years	100 years
<u>ACT</u>			<u>SA</u>		
Canberra	137	194	Adelaide	123	186
<u>NSW</u>			Mt Gambier	108	168
Albury	135	191	Murray Bridge	117	181
Broken Hill	180	181	Port Augusta	124	189
Goulburn	145	197	Port Pirie	125	201
Kiama	224	283	Yorktown	118	197
Newcastle	181	233	<u>WA</u>		
Orange	152	214	Albany	142	217
Sydney	214	273	Broome	252	343
Tweed Heads	245	303	Bunbury	148	215
Wollongong	233	294	Derby	254	343
<u>VIC</u>			Geraldton	132	173
Ballarat	127	184	Kalgoorlie	116	180
Benalla	133	187	Perth	146	214
Geelong	118	172	Port Hedland	233	332
Horsham	120	174	Tom Price	164	222
Lakes Entrance	124	179	<u>TAS</u>		
Melbourne	127	185	Burnie	118	191
Mildura	125	174	Flinders Island	128	184
Stawell	127	185	Hobart	99	155
<u>QLD</u>			Launceston	101	150
Brisbane	251	333	Queenstown	118	183
Bundaberg	241	318	St Marys	205	266
Cairns	282	368	<u>NT</u>		
Cape York	301	388	Alice Springs	139	204
Cloncurry	172	228	Darwin	285	366
Innisfail	254	323	Katherine	230	304
Mackay	273	363			
Mt Isa	169	223			
Noosa	253	320			
Rockhampton	248	336			
Toowoomba	189	251			
Townsville	260	346			
Weipa	293	370			

Amdt 3

Table 3.5.2.2 GUTTER AND DOWNPIPE SELECTION					
Table a. Gutter sizes for various rainfall intensities and roof catchment areas per downpipe					
Design Rainfall Intensity (mm/h) (as per Table 3.5.2.1)	Roof Catchment Area per Downpipe - m ²				
	30	40	50	60	70
	Size of Gutter Required to Drain Roof Catchment Area into One (1) Downpipe (A, B, C, D, E and F defined in Table b.)				
90	A or C	A or C	A or C	A or C	A or C
120	A or C	A or C	A or C	A or C	A or D
140	A or C	A or C	A or C	A or D	B or E
160	A or C	A or C	A or C	A or E	B or E
175	A or C	A or C	A or D	B or E	E
200	A or C	A or C	A or D	B or E	F
225	A or C	A or C	A or B	E	F
255	A or C	A or D	B or E	E	F
275	A or C	A or D	B or E	F	F
325	A or C	B or E	F	F	F
425	A or C	E	F	F	F

Table b
Amdt No. 3

Table b. Gutter sizes for various rainfall intensities		
Gutter Type (as per Table a.)	Gutter description	Minimum Cross Sectional Area mm ²
A	Medium Rectangular Gutter	6500
B	Large Rectangular Gutter	7900
C	115 mm D Gutter	5200
D	125 mm D Gutter	6300
E	150 mm D Gutter	9000
F	Gutter must designed in accordance with AS/NZS 3500.3.2	

Table c. Downpipe selection					
Down pipe Section	Gutter Sections - (as per Table b.)				
	A	B	C	D	E
75 mm dia.	Yes	Yes	Yes	Yes	No
100 mm x 50 mm	Yes	Yes	Yes	Yes	Yes
90 mm dia.	Yes	Yes	Yes	Yes	Yes
100 mm x 75 mm	Yes	Yes	Yes	Yes	Yes
Legend: Yes - downpipe is suitable for the eaves gutter selection; and No - downpipe is not suitable for the eaves gutter selection.					

Explanatory Information:

Stormwater drainage systems specified in the *Housing Provisions* are not designed to remove all of the water during exceptionally heavy rain, especially in tropical areas. Accordingly, it is necessary to design and install the system so that when overflowing occurs any water is directed away from the inside of the building.

This may be achieved by using slotted gutters, locating the gutter so that it is below the top edge of the fascia or installing rainwater heads with overflow slots.

Consideration needs to be given to box gutters, valley gutters etc located above the internal areas of a building. In these situations if adequate overflow controls cannot be implemented there may be a need to increase the size and capacity of drainage components to remove all water anticipated during heavy rain periods.

PART 3.5.3 WALL CLADDING

Appropriate *Performance Requirements*:

Where an alternative wall cladding is proposed to that described in Part 3.5.3, that proposal must comply with *Performance Requirements* P2.1 and P2.2.2 in Section 2.

Acceptable construction practice

3.5.3.1 Application

Compliance with this Part satisfies *Performance Requirements* P2.1 and P2.2.2 for wall cladding, provided-

- (a) the building is located in an area with a *design wind speed* of not more than W41; and

Explanatory Information:

1. Information on *design wind speeds* for particular areas may be available from the *appropriate authority*.
2. A map indicating cyclonic regions of Australia is contained in Part 3.10.1.
3. For wall cladding in a areas with a *design wind speed* of more than W41 refer to the appropriate design manual listed in Part 3.11.

- (b) wall cladding is installed in accordance with-
- (i) 3.5.3.2 for timber weatherboard cladding; and
 - (ii) 3.5.3.3 for fibre cement planks and weatherboard cladding; and
 - (iii) 3.5.3.4 for fibre cement sheet and plywood sheet cladding; and
- (c) fibre cement sheet eaves are installed in accordance with 3.5.3.5; and
- (d) openings in cladding are flashed in accordance with 3.5.3.6.

3.5.3.2 Timber weatherboard cladding

Timber cladding must be installed as follows:

- (a) Splayed timber weatherboards must be fixed in accordance with Figure 3.5.3.1 and with a lap not less than-
- (i) 30 mm for hardwood, cypress and treated pine; and
 - (ii) 20 mm for western red cedar; and

- (iii) 25 mm for baltic pine.
- (b) Profiled timber boards must be-
 - (i) fixed with the overlap and groove closely fitted; and
 - (ii) with tongue and groove profile, fixed tongue edge up.
- (c) Spacing of fixings must be-
 - (i) one nail per board at each stud at not more than 650 mm centres measured along the board; and
 - (ii) nailed so that they do not penetrate the tip or thinner edge of the board beneath, ie for 30 mm lap, nail 35 mm from the butt (see Figure 3.5.3.1.)
- (d) Nails used to fix timber cladding must comply with the following:
 - (i) Where nails are punched and filled prior to painting, be standard steel bullet-head nails.
 - (ii) Uncoated copper or steel nails must not be used for western red cedar (silicon bronze, monel metal, stainless steel or hot dipped galvanised are suitable).
 - (iii) In all other cases, nails must be hot-dipped galvanised flat head or bullet head.
- (e) Acceptable nail sizes are-
 - (i) for hardwood and cypress frames - 50x2.8 mm plain shank; and
 - (ii) for softwood frames - 50x3.15 mm annular threaded.

3.5.3.3 Fibre cement planks and weatherboard cladding

Fibre cement plank and weatherboard cladding must be installed as follows:

- (a) 7.5 mm (minimum) fibre cement planks and weatherboards must be-
 - (i) manufactured in accordance with AS 2908.2; and
 - (ii) fixed with a lap of not less than 25 mm (see Figure 3.5.3.1).
- (b) 7.5 mm (minimum) fibre cement planks and weatherboards must be fixed in accordance with Figure 3.5.3.1 with a stud spacing of not more than 600 mm.
- (c) Acceptable fixings for 7.5 mm fibre cement planks and weatherboards are-
 - (i) for timber studs - 40x2.8 mm galvanised fibre cement nails; and
 - (ii) for steel studs - 8-18 x 35 mm self embedding head screws (see Figure 3.5.3.1).

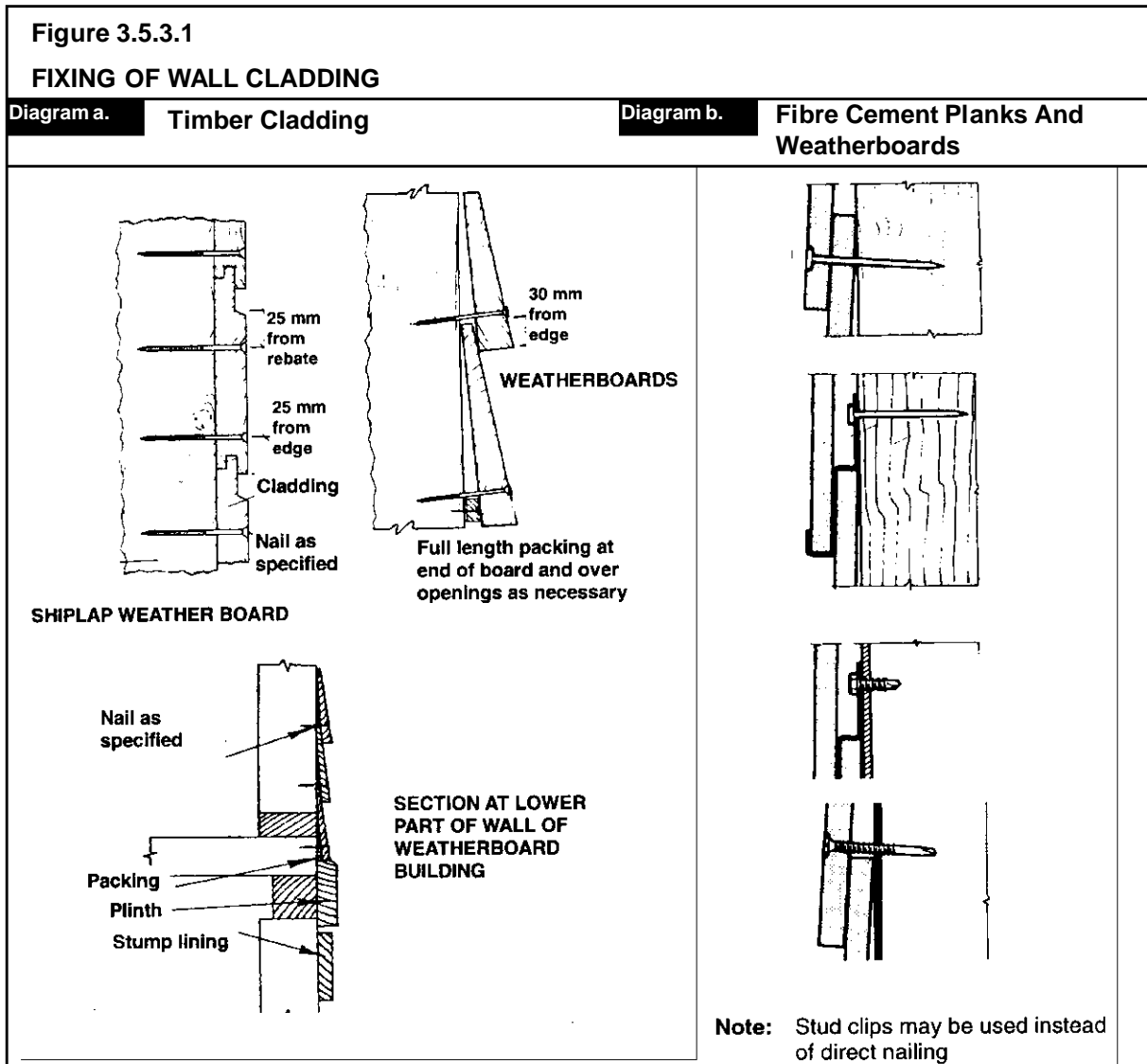

Amdt 3

3.5.3.4 Sheet wall cladding

- (a) Fibre cement sheets must comply as follows:
 - (i) Fibre cement sheets used as external wall cladding must be fixed in accordance with Table 3.5.3.1 and Figure 3.5.3.2.
 - (ii) Where the external cladding also acts as structural sheet bracing, the lesser of the stud and fixing spacings for both applications must be used.
 - (iii) External fibre cement sheets and claddings must comply with AS 2908.2.

Design wind speed	STUD SPACING		NAIL SPACING (2.8 mm fibre cement nails)			
	Within 1.2 m of ends of building	Elsewhere	Within 1.2 m of ends of building		Elsewhere	
			Body	Edges	Body	Edges
W28	600	600	300	200	300	200
W33	600	600	200	200	300	200
W41	450	600	200	200	200	200

Amdt 3

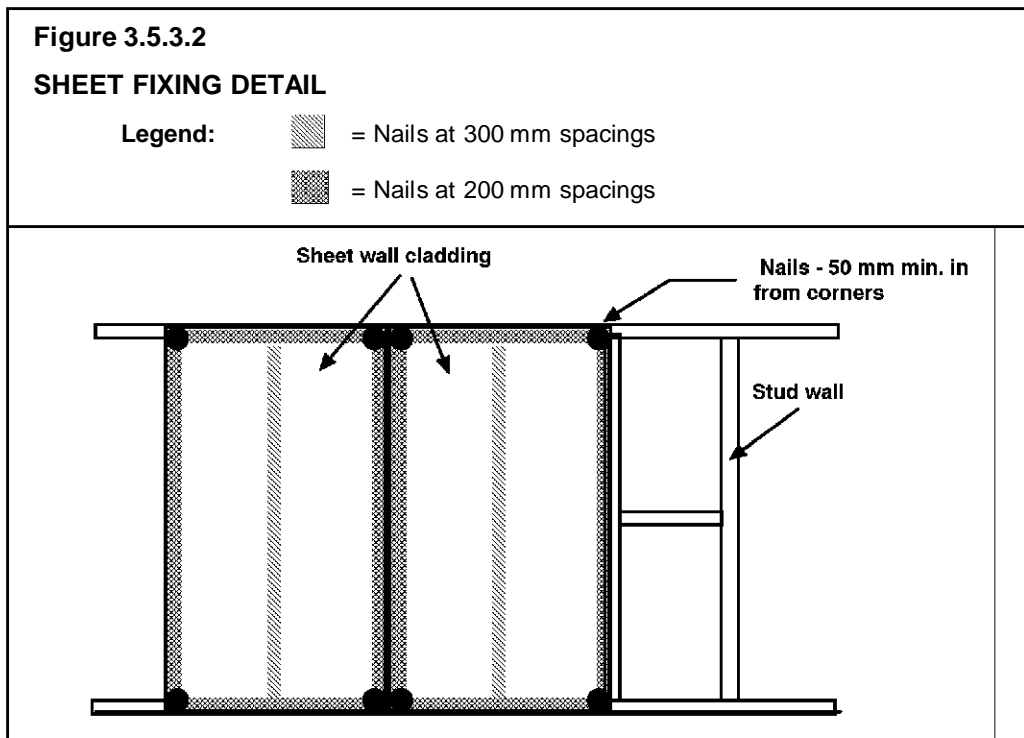

- (b) Structural plywood external cladding must comply as follows:
- (i) Structural plywood cladding must comply with AS 2269.
 - (ii) Where structural plywood acts as cladding and combined structural bracing it must comply with Table 3.5.3.2.
 - (iii) Sheets, not more than 9 mm thick must be fixed using 2.8/3.5x30 mm long galvanised clouts or flat head nails spaced at-
 - (A) 150 mm centres along sheet edges; and

- (B) 300 mm centres for intermediate fixings; and
- (iv) Sheets thicker than 9 mm must be fixed with 2.8 or 3.5 mm galvanised clouts or flat head nails with a length calculated using the following formula:

$$\text{MIN NAIL LENGTH } L = PL + 10 Da$$

Where PL = Plywood thickness and
Da = Diameter of nail

- (v) The fixings must be located not less than 9 mm from the edge of the sheet.

Explanatory Information:
 The above formula is applied as follows:
 For 12 mm plywood and 2.8 mm diameter nail
 $L = 12 + 28 \text{ mm}$; therefore the minimum nail length must be 40 mm.

Amdt 3

Table 3.5.3.2						
MINIMUM STRUCTURAL PLYWOOD THICKNESS FOR COMBINED BRACING AND EXTERNAL CLADDING (mm)						
Plywood stress grade	Stud spacing (mm)					
	Plywood face grain Parallel to studs			Plywood face grain At right angles to studs		
	450	600	900	450	600	900
F8	9	12	16	7	9	12
F11	8	12	16	6	8	12
F14	7	12	16	6	7	12

3.5.3.5 Eaves and soffit linings

External fibre cement sheets and linings used as eaves and soffit linings must-

- (a) comply with AS 2908.2; and
- (b) be fixed in accordance with Table 3.5.3.3 and Figure. 3.5.3.3 using-
 - (i) 2.8 x 30 mm Fibre cement nails; or
 - (ii) No. 8 Wafer head screws (for 4.5 mm and 6 mm sheets only); or
 - (iii) No. 8 Self embedding head screws (for 6 mm sheets only).

Table 3.5.3.3
TRIMMER AND FASTENER SPACINGS FOR 4.5 AND 6 mm FIBRE CEMENT EAVES AND SOFFIT LININGS

Maximum eaves Width	Design wind speed	Maximum Trimmer spacings (mm)		Maximum Fastener Spacings (mm)	
		Within 1200 mm of the external corners of the building	Remainder of sheet	Within 1200 mm of the external corners of the building	Remainder of sheet
600	W28	600	900	200	300
	W33	600	800	200	300
	W41	500	700	200	300
1200	W28	600	750	200	300
	W33	600	700	200	300
	W41	500	650	200	300

Amdt 3

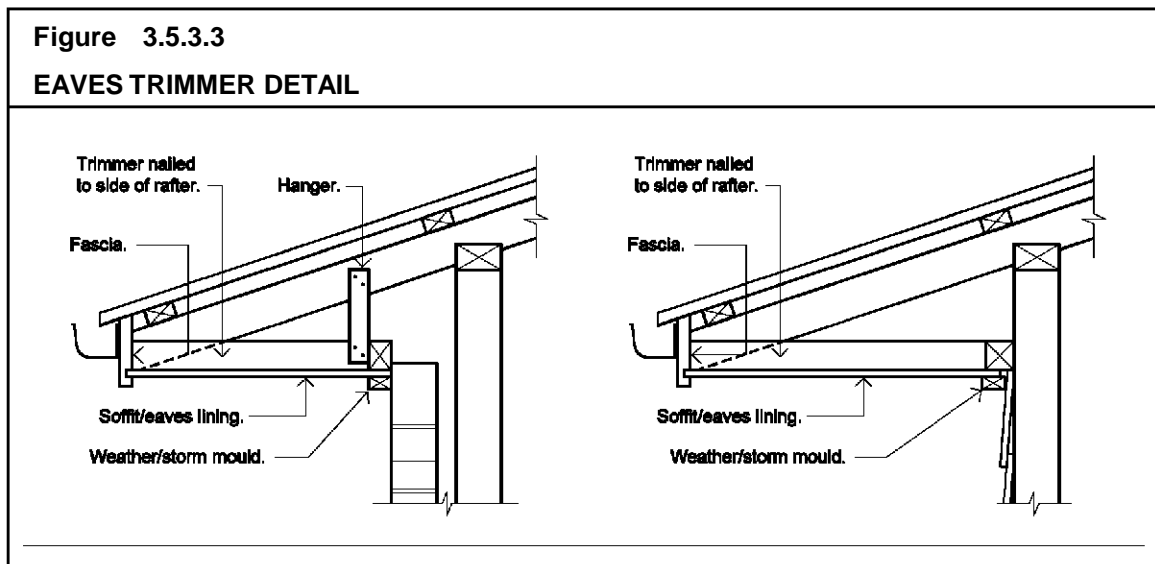

3.5.3.6 Flashings to wall openings

Openings in external wall cladding exposed to the weather must be flashed as follows:

- (a) All openings must be adequately flashed using materials that comply with AS 2904.

- (b) Flashings must be securely fixed not less than 25 mm under the cladding and extend over the ends and edges of the framing of the opening (see Figure 3.5.3.4).

Figure 3.5.3.4
TYPICAL WINDOW FLASHING DETAIL

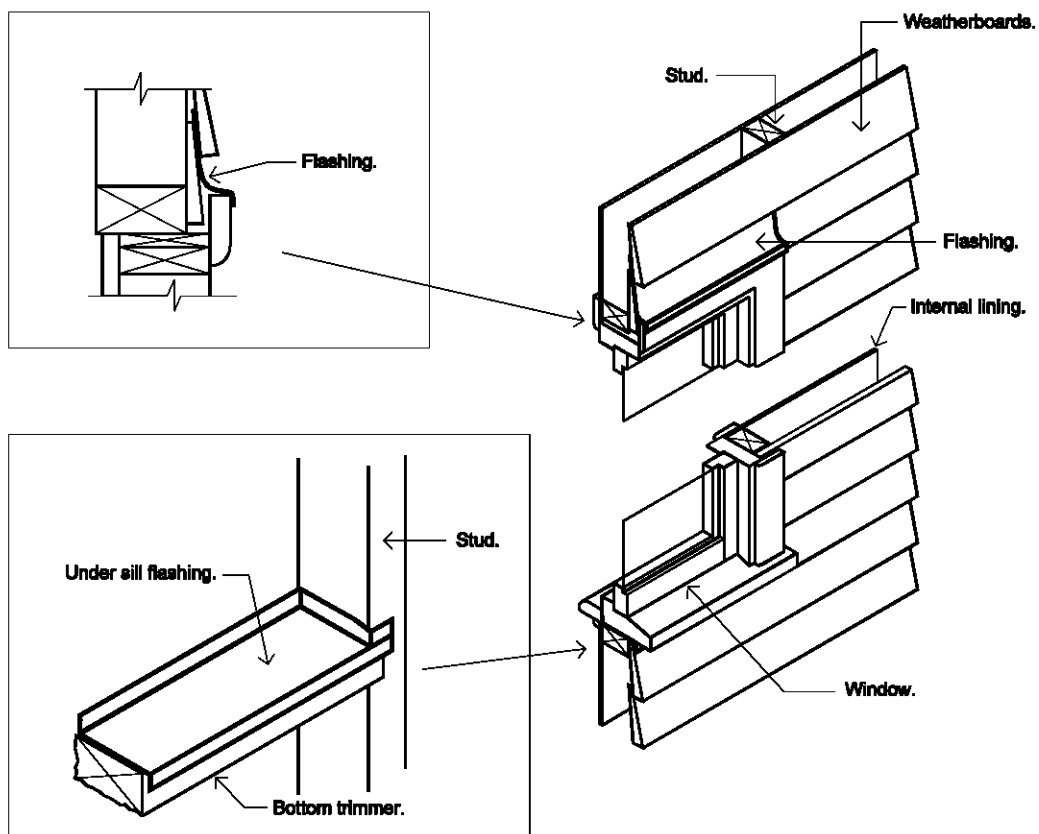

Amdt 3

PART 3.6

Amdt 3

GLAZING

- 3.6 Definitions**
 - 3.6.0 Acceptable Construction Manual**
 - 3.6.1 Application**
 - 3.6.2 Glazing Sizes and Installation**
 - 3.6.3 Perimeter Framed Glazing**
 - 3.6.4 Human Impact Safety Requirements**
 - 3.6.5 Doors**
 - 3.6.6 Side Panels**
 - 3.6.7 Full Height Framed Panels**
 - 3.6.8 Glazed Panels, Other than Doors or Side Panels on the Perimeter of Rooms**
 - 3.6.9 Shower Doors, Shower Screens and Bath Enclosures**

PART 3.6 CONTENTS

		Page
3.6	Glazing	15,021
3.6	Definitions	
3.6.0	Acceptable construction manual	
3.6.1	Application	
3.6.2	Glazing sizes and installation	
3.6.3	Perimeter framed glazing	
3.6.4	Human impact safety requirements	
3.6.5	Doors	
3.6.6	Side panels	
3.6.7	Full height framed glazed panels	
3.6.8	Glazed panels, other than doors or side panels, on the perimeter of rooms	
3.6.9	Shower doors, shower screens and bath enclosures	

PART 3.6 GLAZING

Appropriate *Performance Requirements*:

Where an alternative glazing system is proposed to that described in Part 3.6, that proposal must comply with *Performance Requirements* P2.1 and P2.2.2 in Section 2-

Definitions

3.6 The following definitions are used in this Part:

Perimeter of building means the external envelope of a building.

Unobstructed opening means a glazed area that a person could mistake for an open doorway or clearway and walk into the glazed panel.

A. Acceptable construction manuals

3.6.0 *Performance Requirements* P2.1 and P2.2.2 are satisfied for glazing if it is installed in Class 1 and 10 buildings in accordance with AS 1288- Glass in buildings - Selection and installation.

B. Acceptable construction practice

3.6.1 Application

Compliance with this Part satisfies *Performance Requirements* P2.1 and P2.2.2 for glazing, provided-

(a) the building is located in an area with a *design wind speed* of not more than W41; and

Explanatory Information:

1. Information on *design wind speeds* for particular areas may be available from the *appropriate authority*.
2. For glazing in *high wind areas* refer to AS 1288.

(b) glass is manufactured in accordance with AS 1288; and

(c) safety glazing is legibly marked in accordance with AS 1288; and

(d) glazing used in balustrades and sloped overhead glazing complies with AS 1288.

3.6.2 Glazing sizes and installation

Glazing used in buildings must comply with the following:

- (a) Glazing used in the *perimeter of buildings* and supported on all sides must comply with the appropriate provisions listed in 3.6.3.
- (b) Glazing used in areas where the potential for human impact could occur must comply with the appropriate provisions listed in 3.6.4.

3.6.3 Perimeter framed glazing (supported on all sides)

Glazing installed in the *perimeter of buildings* must comply with-

- (a) for ordinary annealed fully framed glass - Table 3.6.1 (see also Figure 3.6.2); and
- (b) for ordinary annealed patterned fully framed glass - Table 3.6.1.

Explanatory Information:
 For other types of perimeter glazing including toughened, wired, laminated and unframed glazing refer to AS 1288.

Table 3.6.1			
FULLY FRAMED GLASS - MAXIMUM AREAS IN SQUARE METRES			
Minimum nominal thickness (mm)	<i>Design Wind Speed</i>		
	W28	W33	W41
Ordinary annealed fully framed glass			
3	2.0	1.4	1.0
4	3.5	2.4	1.7
5	5.2	3.6	2.6
6	7.4	5.2	3.6
8	11.0	7.9	5.4
Ordinary annealed, patterned, fully framed glass			
3	1.7	1.1	0.8
4	3.0	2.1	1.5
5	4.8	3.3	2.4
6	6.6	4.8	3.5

3.6.4 Human impact safety requirements

The thickness and type of glazing installed in areas of a building that have a high potential for human impact (an area of a building frequented by the occupants

during everyday activities in which a person could fall into or against the glazed panel) must comply as follows:

- (a) Doors - in accordance with 3.6.5.
- (b) Door side panels - in accordance with 3.6.6.
- (c) Full height glass panels - in accordance with 3.6.7.
- (d) Glazed panels, other than doors or side panels, on the perimeter of rooms - in accordance with 3.6.8.
- (e) Shower screens, shower doors and bath enclosures - in accordance with 3.6.9.

3.6.5 Doors

Glass (except leadlight panels) in doors must be Grade A safety glazing material in accordance with Table 3.6.3 and Figure 3.6.1, except that-

- (a) in fully framed panels, ordinary annealed glass with an area of not more than 0.5 m^2 in accordance with Table 3.6.4 may be used provided a chair rail not less than 40 mm wide is installed in the door; and
- (b) unframed doors must be glazed with toughened safety glass with a standard nominal thickness of not less than 10 mm; and
- (c) doors to showers and bath enclosures must be glazed in accordance with 3.6.9.

3.6.6 Side panels

- (a) All framed glass (except leadlight panels) in side panels with their nearest vertical sight line less than 300 mm from the nearest edge of the doorway opening must be of Grade A safety glazing material in accordance with Table 3.6.3 and Figure 3.6.1, except that-
 - (i) where the lowest visible sight line is not less than 1.2 m above the highest abutting finished floor level, ordinary annealed glass in accordance with Table 3.6.2 may be used; or
 - (ii) where the lowest visible sight line is less than 1.2 m above the highest abutting finished floor level, ordinary annealed glass in accordance with Table 3.6.4, with an area of not more than 0.5 m^2 , may be used.
- (b) Framed glass panels with the nearest vertical sight line not less than 300 mm from the nearest edge of the door opening are not considered to be side panels for the purposes of the *Housing Provisions*.

Table 3.6.2 MAXIMUM AREAS OF ORDINARY ANNEALED GLASS IN SIDE PANELS	
Minimum nominal thickness (mm)	Maximum area of pane (m ²)
3	0.8
4	1.4
5	2.2
6	3.3

3.6.7 Full height framed glazed panels

- (a) A glazed panel located in a building so that it is capable of being mistaken for an *unobstructed opening* must be glazed with-
- (i) Grade A safety glazing material in accordance with Table 3.6.3, or
 - (ii) ordinary annealed glass complying with Table 3.6.3 provided the glazed area is not more than 0.9 m².
- (b) Glazed panels are not considered capable of being mistaken for an *unobstructed opening* where any of the following apply:
- (i) The clear opening width is not more than 500 mm.
 - (ii) The lowest sight line of the opening is not less than 500 mm above the highest abutting finished floor level.
 - (iii) The glass is marked by means of a permanent motif or other decorative treatment on or etched into the glass, of sufficient magnitude to be readily apparent, or the glass is opaquely coloured or patterned to indicate its presence.
 - (iv) A chair rail or handrail not less than 40 mm thick, or the like is provided at a height of 865 mm above the adjoining ground level.
 - (v) Internal partitions clearly form walls of a passageway and conform with item (a).
 - (vi) The difference in floor level on either side of the panel is not less than 500 mm.

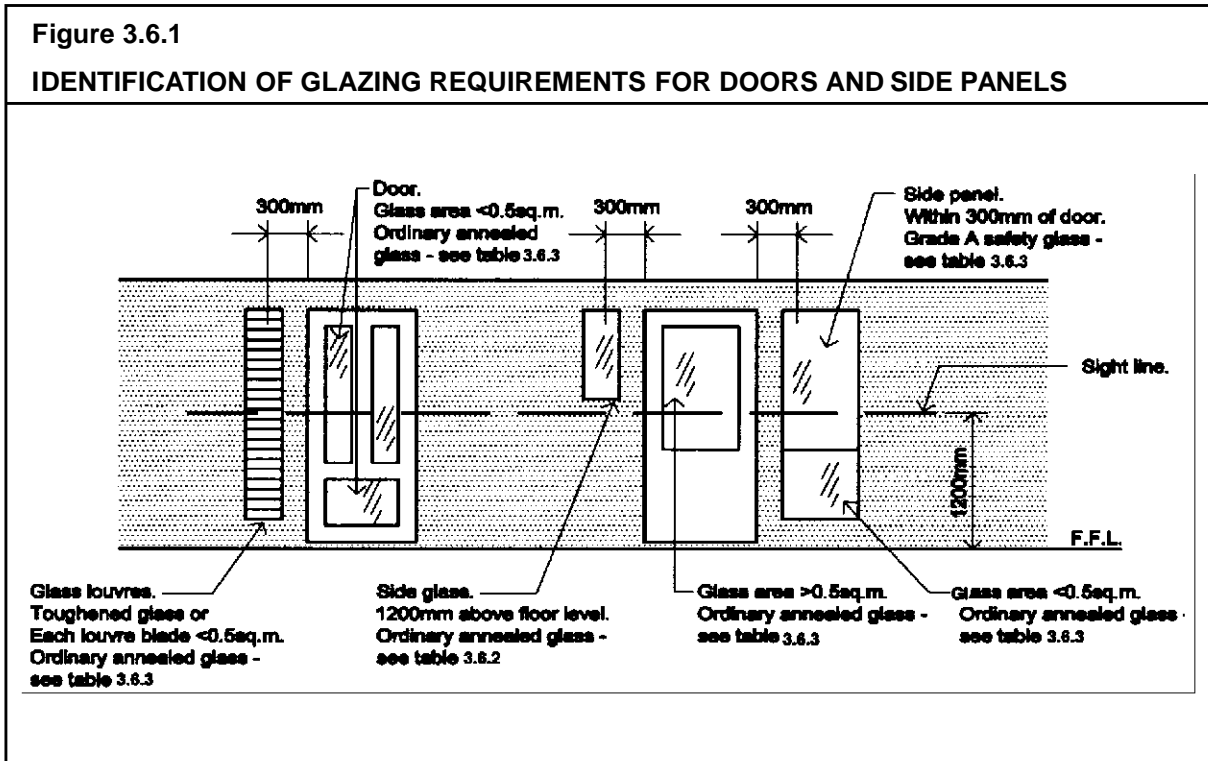

Amdt 3

Table 3.6.3
MAXIMUM AREAS OF GLAZING MATERIAL FOR FRAMED GLASS DOORS, FRAMED GLASS SIDE PANELS, AND OTHER FRAMED GLAZED PANELS

Type of Glass	Minimum nominal thickness (mm)	Maximum area of pane (m ²)
Patterned or clear ordinary annealed glass	3	0.1
	4	0.3
	5	0.5
	6	0.9
Grade A Toughened safety glass	3	1
	4	2
	5	3
	6	4
Grade A Laminated safety glass	5.38	2
	6.38	3
	8.38	5

3.6.8 Glazed panels, other than doors or side panels, on the perimeter of rooms

All framed glazing where the lowest sight line of the glazing panel is less than 500 mm from the highest abutting finished floor level must be-

- (a) Grade A safety glazing material in accordance with Table 3.6.3; or
- (b) ordinary annealed glass in accordance with Table 3.6.4 (see also Figure 3.6.2).

Table 3.6.4
MAXIMUM AREAS OF ORDINARY ANNEALED GLASS WHERE THE LOWEST SIGHT LINE IS LESS THAN 500 MM FROM THE HIGHEST ABUTTING FLOOR LEVEL

Minimum nominal thickness (mm)	Maximum area of pane (m ²)
3	0.1
4	0.3
5	2.0

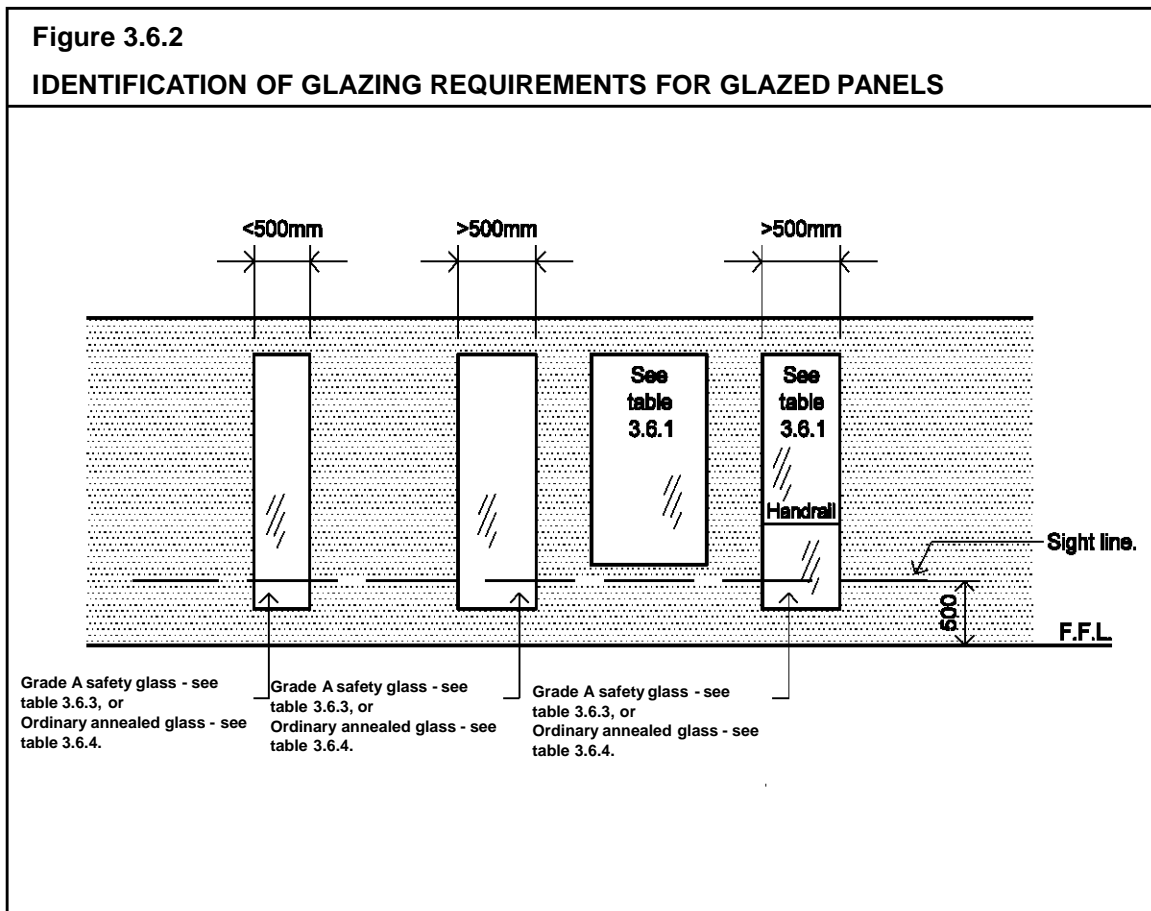

Amdt 3

3.6.9 Shower doors, shower screens and bath enclosures

- (a) All shower doors, shower screens, bath enclosures, and associated *windows*, where the lowest sight line is less than 1.5 m above the highest abutting finished level of the floor, bottom of the bath, or shower base, must-
- (i) for framed panels, be glazed with-
 - (A) Grade A safety glazing material in accordance with Table 3.6.3;
or
 - (B) Grade B safety glazing material in accordance with Table 3.6.5;
or
 - (ii) for panels or doors with any edge exposed, be toughened safety glass in accordance with Table 3.6.3 with a nominal thickness of not less than 5 mm.
- (b) For the purpose of this Part-
- (i) a *window* is part of a bath enclosure or shower if it is less than 500 mm horizontally from the internal perimeter of the floor of the bath or shower (see Figure 3.6.3); and
 - (ii) a *window* is not part of the bath or shower if a person in the bath or shower is protected from the *window* by permanent safety glazing or permanent material able to resist human impact.
- (c) Associated *windows* referred to in (b) (i), in *external walls* may incorporate annealed glass panels of not less than 4 mm thickness, provided that they are not more than 0.1 m² in area.

Explanatory Information:

Care should be taken when using showers fitted with safety wired glass, safety organic-coated glass, and laminated safety glass products that are liable to damage from thermal shock. Thermal shock occurs from hot water from the shower hitting the shower screen during cold weather.

Table 3.6.5
MAXIMUM AREAS OF GRADE B SAFETY GLAZING MATERIALS FOR SHOWER DOORS, SHOWER SCREENS AND BATH ENCLOSURES

Type of Glass	Standard nominal thickness (mm)	Maximum area of pane (m ²)	Area (Fig. 3.6.3)
Safety wired glass	Greater than or equal to 6	2.5	A, B, C
Safety organic coated glass	3	1	A, B, C, D
	4	1.5	
	5	2	
	Greater than or equal to 6	3	

Amdt 3

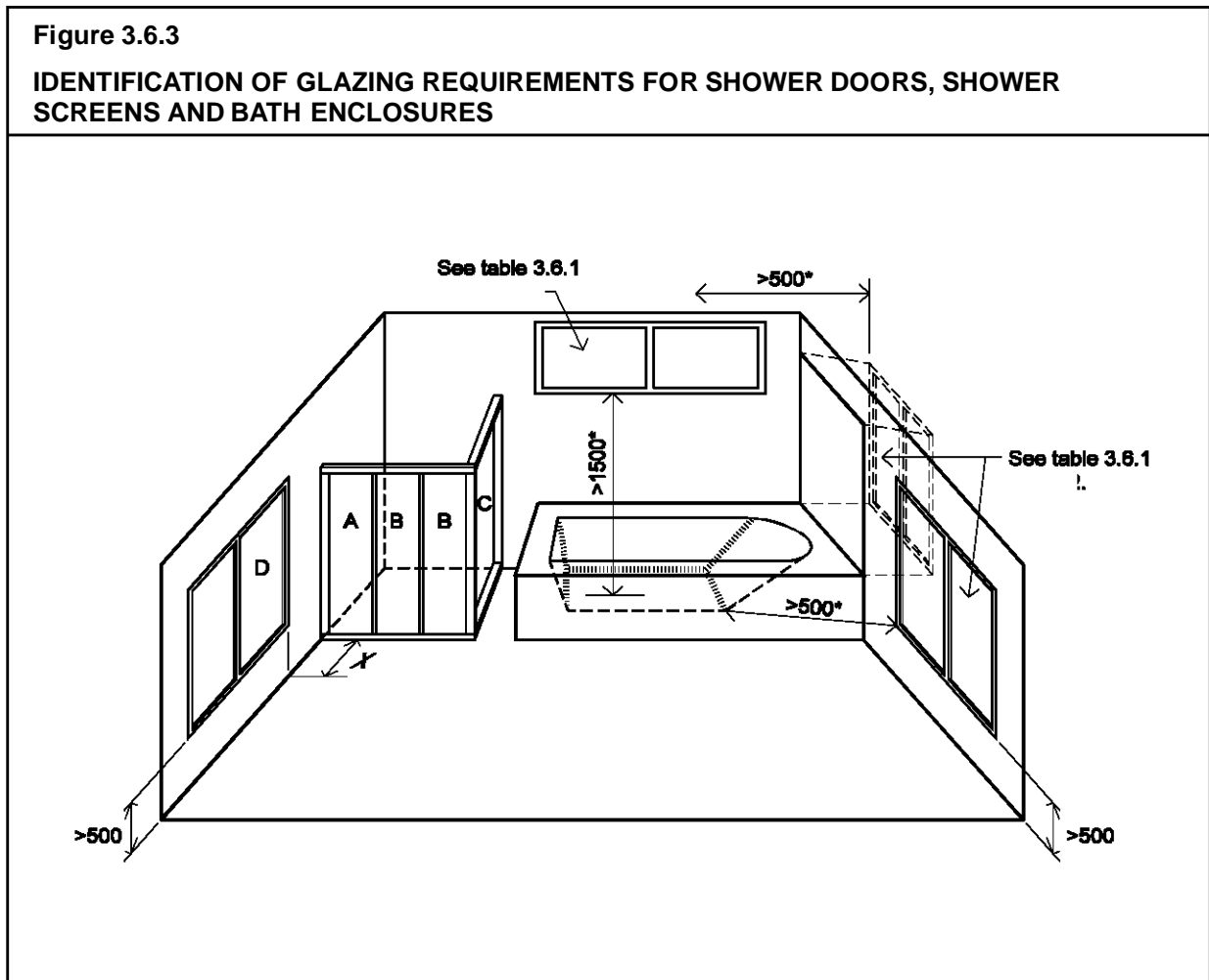

PART **3.7**

Amdt 3

FIRE SAFETY

- 3.7.1 Fire Separation**
- 3.7.2 Smoke Alarms**
- 3.7.3 Heating Appliances**
- 3.7.4 Bushfire Areas**
- 3.7.5 Alpine Areas**

PART 3.7 CONTENTS

	Page	
3.7.1	Fire separation	17,021
3.7.1.1	Application	
3.7.1.2	General concession - non-combustible materials	
3.7.1.3	External walls of Class 1 buildings	
3.7.1.4	Measurement of distances	
3.7.1.5	Construction of external walls	
3.7.1.6	Class 10a buildings	
3.7.1.7	Allowable encroachments	
3.7.1.8	Separating walls	
3.7.1.9	Sarking type materials	
3.7.1.10	Roof lights	
3.7.2	Smoke alarms	17,301
3.7.2.1	Application	
3.7.2.2	Requirements for smoke alarms	
3.7.2.3	Location - Class 1a buildings	
3.7.2.4	Location - Class 1b buildings	
3.7.2.5	Lighting to assist evacuation – Class 1b buildings	
	Explanatory information - Smoke alarms	
3.7.3	Heating appliances	17,501
3.7.3.0	Acceptable construction manuals	
3.7.3.1	Application	
3.7.3.2	Open fireplace construction	
3.7.3.3	Chimney construction	
3.7.3.4	Installation of insert fireplaces and flues	
3.7.3.5	Installation of free standing heating appliances	
3.7.4	Bushfire areas	17,701
3.7.4.0	Acceptable construction manuals	
3.7.4.1	Application	
3.7.4.2	Bushfire protection	
3.7.5	Alpine areas	17,901
3.7.5.1	Application	
3.7.5.2	External doorways	
3.7.5.3	External ramps	
3.7.5.4	Discharge of external doorways providing means of egress	
3.7.5.5	External trafficable structures	

PART 3.7.1 FIRE SEPARATION

Appropriate *Performance Requirements*

Where an alternative fire separation design is proposed to that described in Part 3.7.1, that proposal must comply with *Performance Requirement P2.3.1* in Section 2.

Acceptable construction practice

3.7.1.1 Application

Compliance with this Part satisfies *Performance Requirement P2.3.1* for fire separation.

3.7.1.2 General concession - non-combustible materials

The following materials, though *combustible* or containing *combustible* fibres, may be used wherever a *non-combustible* material is *required* in the *Housing Provisions*-

- (a) plasterboard; and
- (b) perforated gypsum lath with a normal paper finish; and
- (c) fibrous-plaster sheet conforming to AS 2185 Specification for Fibrous Plaster Products; and
- (d) fibre-reinforced cement sheeting; and
- (e) pre-finished metal sheeting having a *combustible* surface finish not more than 1 mm thick and where the *Spread-of-Flame Index* of the product is not more than 0; and
- (f) bonded laminated materials where-
 - (i) each laminate is *non-combustible*; and
 - (ii) each adhesive layer is not more than 1 mm thick; and
 - (iii) the total thickness of adhesive layers is not more than 2 mm; and
 - (iv) the *Spread-of-Flame Index* and the *Smoke-Developed Index* of the laminated material as a whole is not more than 0 and 3 respectively.

3.7.1.3 External walls of Class 1 buildings

An *external wall* of a Class 1 building, and any openings in that wall, must comply with 3.7.1.5 if the wall is less than-

- (a) 900 mm from an allotment boundary other than the boundary adjoining a road alignment or other public space; or

- (b) 1.8 m from another building on the same allotment other than an appurtenant Class 10 building or a detached part of the same Class 1 building.

3.7.1.4 Measurement of distances

- (a) The distance from any point on an *external wall* of a building to an allotment boundary or another building is the distance to that point measured along a line at right angles from the allotment boundary or *external wall* of the other building which intersects that point without being obstructed by a wall complying with 3.7.1.5.
- (b) Where a wall within a specified distance is *required* to be constructed in a certain manner, only that part of the wall (including any openings) within the specified distance need be constructed in that manner.

(see Figure 3.7.1.1 and 3.7.1.2)

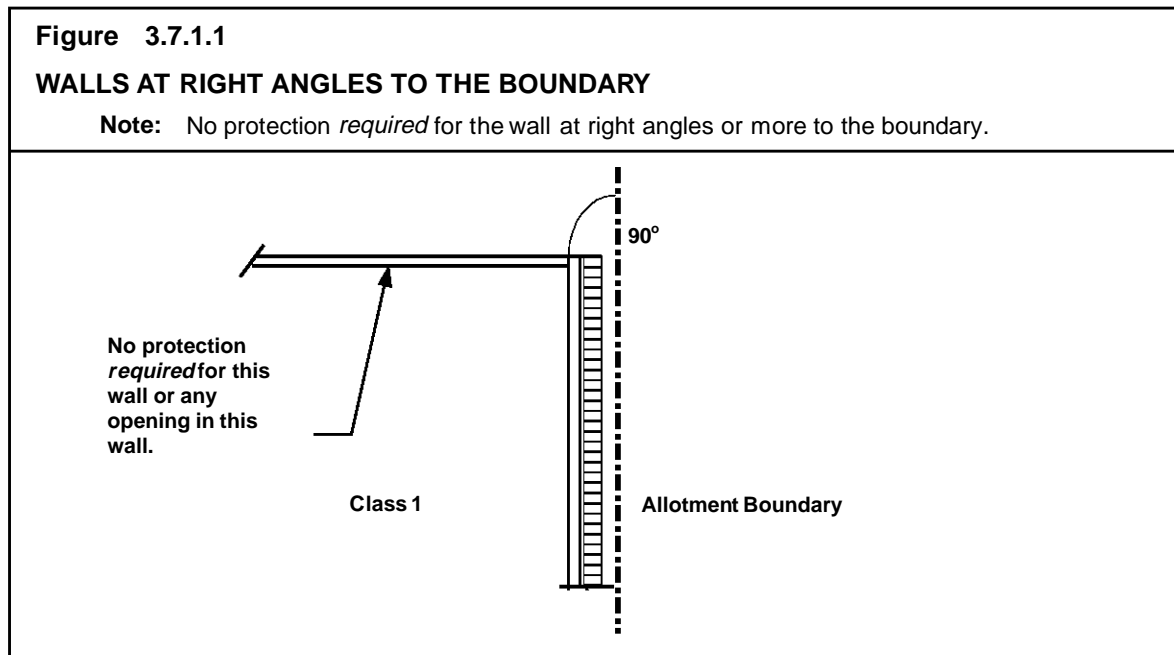

3.7.1.5 Construction of external walls

- (a) *External walls* (including gables) *required* to be *fire resisting* (referred to in 3.7.1.3 or 3.7.1.6) must extend to the underside of a *non-combustible* roof covering or *non-combustible* eaves lining and must-
- have an FRL of not less than 60/60/60 when tested from the outside; or
 - be of masonry-veneer construction in which the external masonry veneer is not less than 90 mm thick; or

- (iii) be of masonry construction not less than 90 mm thick.

(See Figure 3.7.1.3(a) and (b))

Explanatory Information:
See Figure 3.7.1.10 and 3.8.6.3 for internal *separating wall* construction under one common roof.

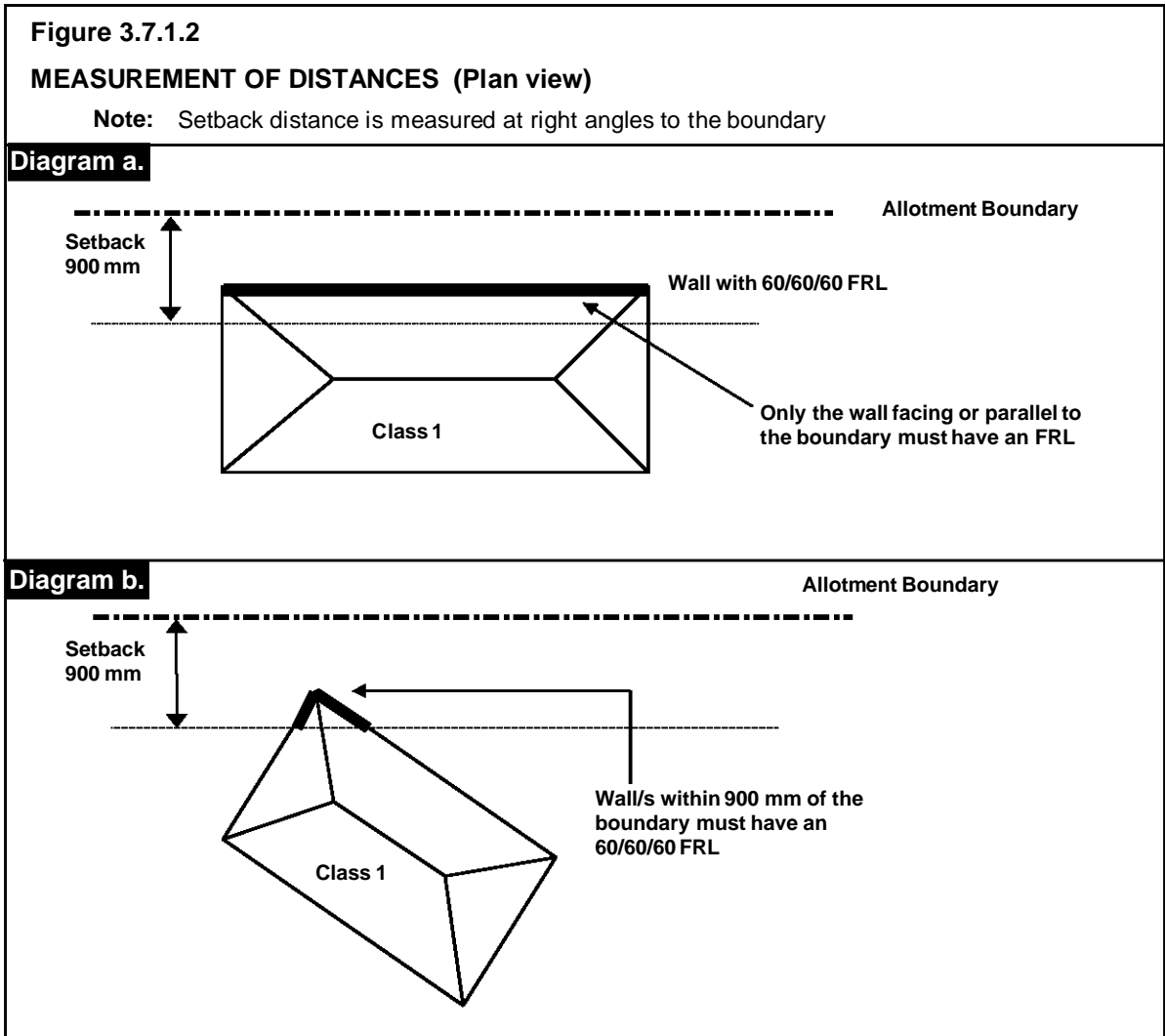

Amdt 3

- (b) Openings in *external walls* required to be *fire resisting* (referred to in 3.7.1.3 or 3.7.1.6) must be protected by-
 - (i) non-openable fire *windows* or other construction with an FRL of not less than - /60/ - ; or
 - (ii) *self-closing* solid core doors not less than 35 mm thick.

- (c) Sub-floor vents, roof vents, weepholes and penetrations for pipes, conduits and the like need not comply with (b).
- (d) Concessions for boundary *windows*

Despite the requirements in (b), in a Class 1a or Class 10 building a *window* to a non-habitable room that faces the boundary of an adjoining allotment may be 600 mm from that boundary provided the opening is not more than 900x600 mm and-

- (i) the *window* is steel framed, there are no opening sashes and it is glazed in wired glass; or
- (ii) the opening is enclosed with translucent hollow glass blocks.

3.7.1.5(d)(ii)
Amdt No. 3

Figure 3.7.1.3(a)

ACCEPTABLE CONSTRUCTION OF EXTERNAL WALLS

Note: Wall to extend to the underside of *non-combustible* roof covering; or *non-combustible* eaves lining.

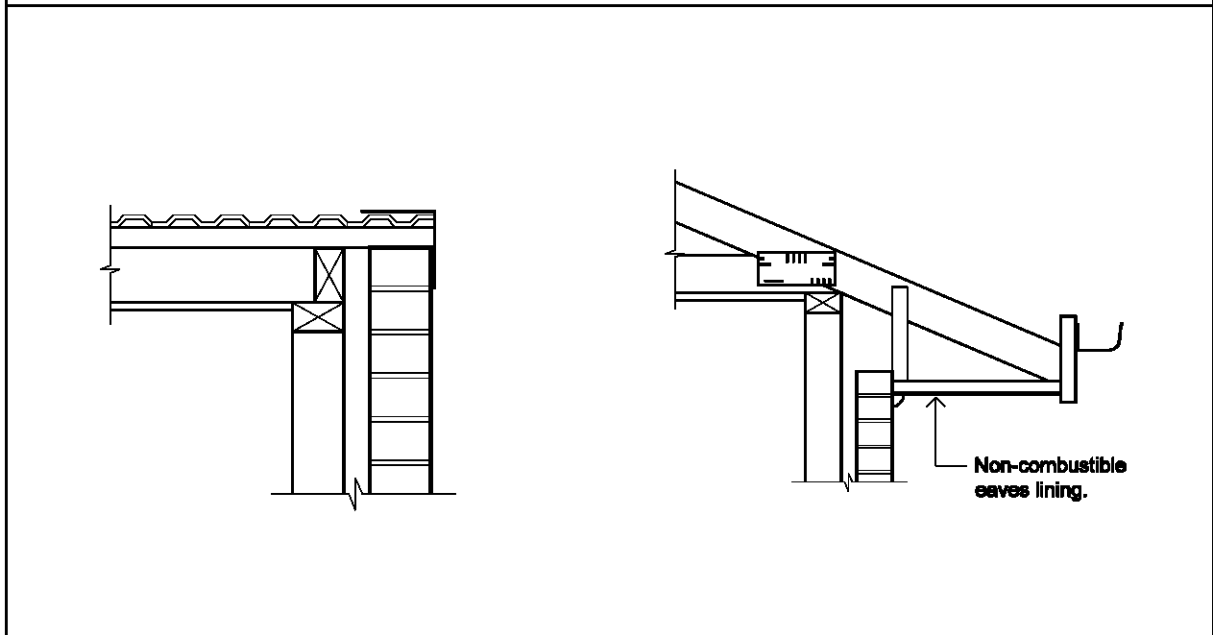
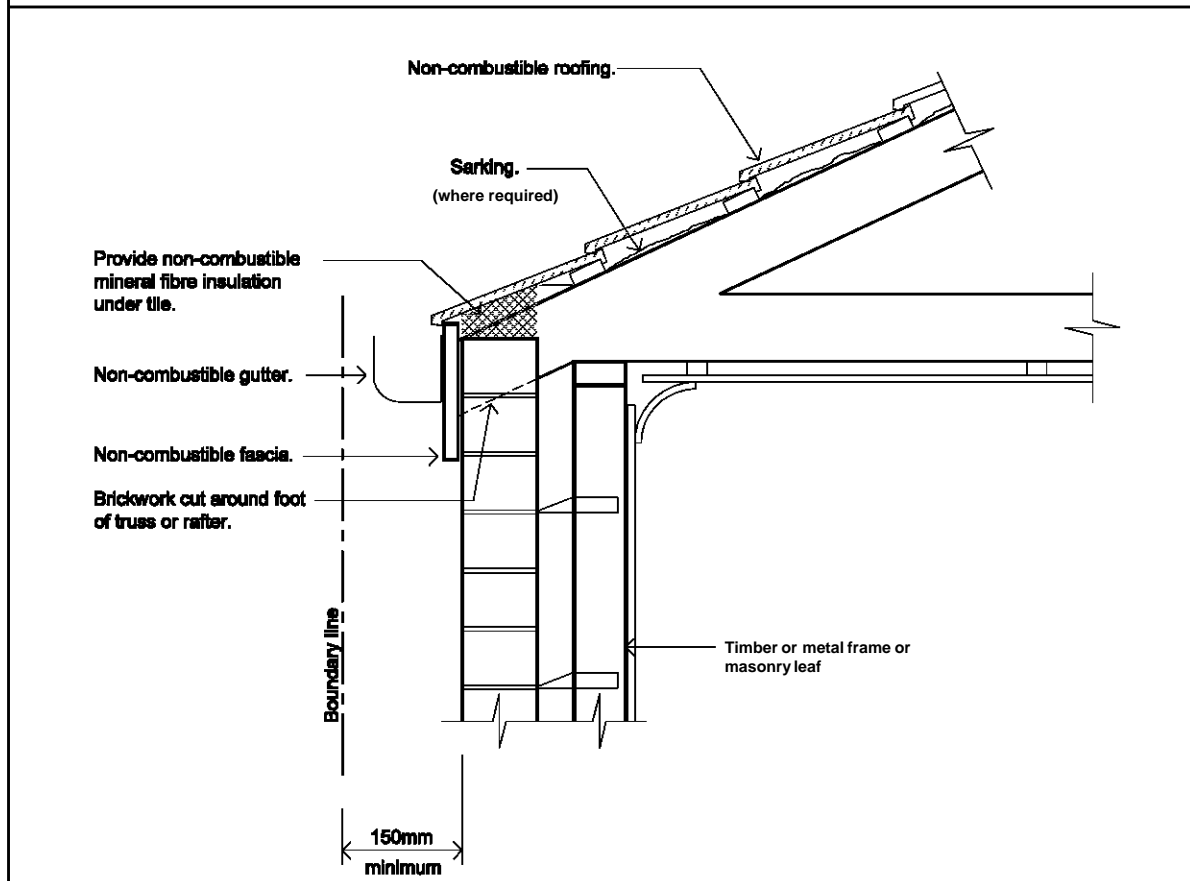

Figure 3.7.1.3(b)

ACCEPTABLE CONSTRUCTION OF EXTERNAL WALLS

Notes:

1. The *external wall* must extend to the underside of a *non-combustible* roof covering; or *non-combustible* eaves lining.
2. Where sarking is installed it must be located so that ponding of water is avoided between the fascia and the first roofing batten.



3.7.1.6 Class 10a buildings

- (a) Where a Class 10a building is located between a Class 1 building and the allotment boundary, other than the boundary adjoining a road alignment or other public space, the Class 1 building must be protected by one of the methods shown in Figure 3.7.1.4.
- (b) Where a Class 10a building is located between a Class 1 building to which it is appurtenant and another building on the same allotment, the Class 1 building must be protected by one of the methods shown in Figure 3.7.1.5.
- (c) Where two or more Class 10a buildings on the same allotment are appurtenant to different Class 1 buildings, the Class 10a buildings must be separated in accordance with one of the methods shown in Figure 3.7.1.6.

Figure 3.7.1.4

PROTECTION OF CLASS 1 BUILDINGS - CLASS 10a BETWEEN CLASS 1 AND THE ALLOTMENT BOUNDARY

Legend:

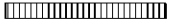
 Wall with an FRL of 60/60/60

 Allotment boundary

a. 900 mm from allotment boundary

The Class 10a building is not less than 900 mm from the allotment boundary, other than the boundary adjoining a road alignment or other public space.

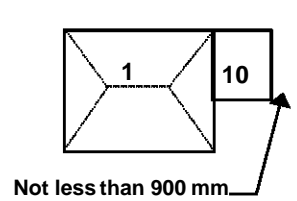

b. External wall to Class 10a building with FRL

An *external wall* of the Class 10a building which is less than 900 mm from an allotment boundary, other than the boundary adjoining a road alignment or other public space, complies with 3.7.1.5.

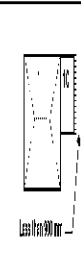

c. External wall to Class 10a building with FRL

An *external wall* of the Class 10a building which is less than 900 mm from the Class 1 building complies with 3.7.1.5.

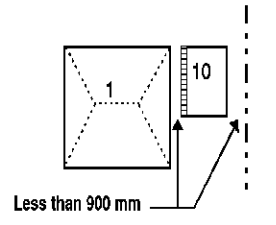

d. 900 mm separation between buildings

The Class 1 building is not less than 900 mm from the Class 10a building.

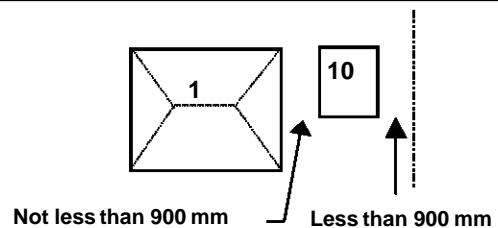

e. Class 1 building with FRL to external wall

An *external wall* of the Class 1 building which is less than 900 mm from the Class 10a building complies with 3.7.1.5.

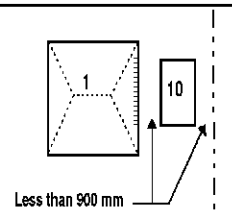

Amdt 3

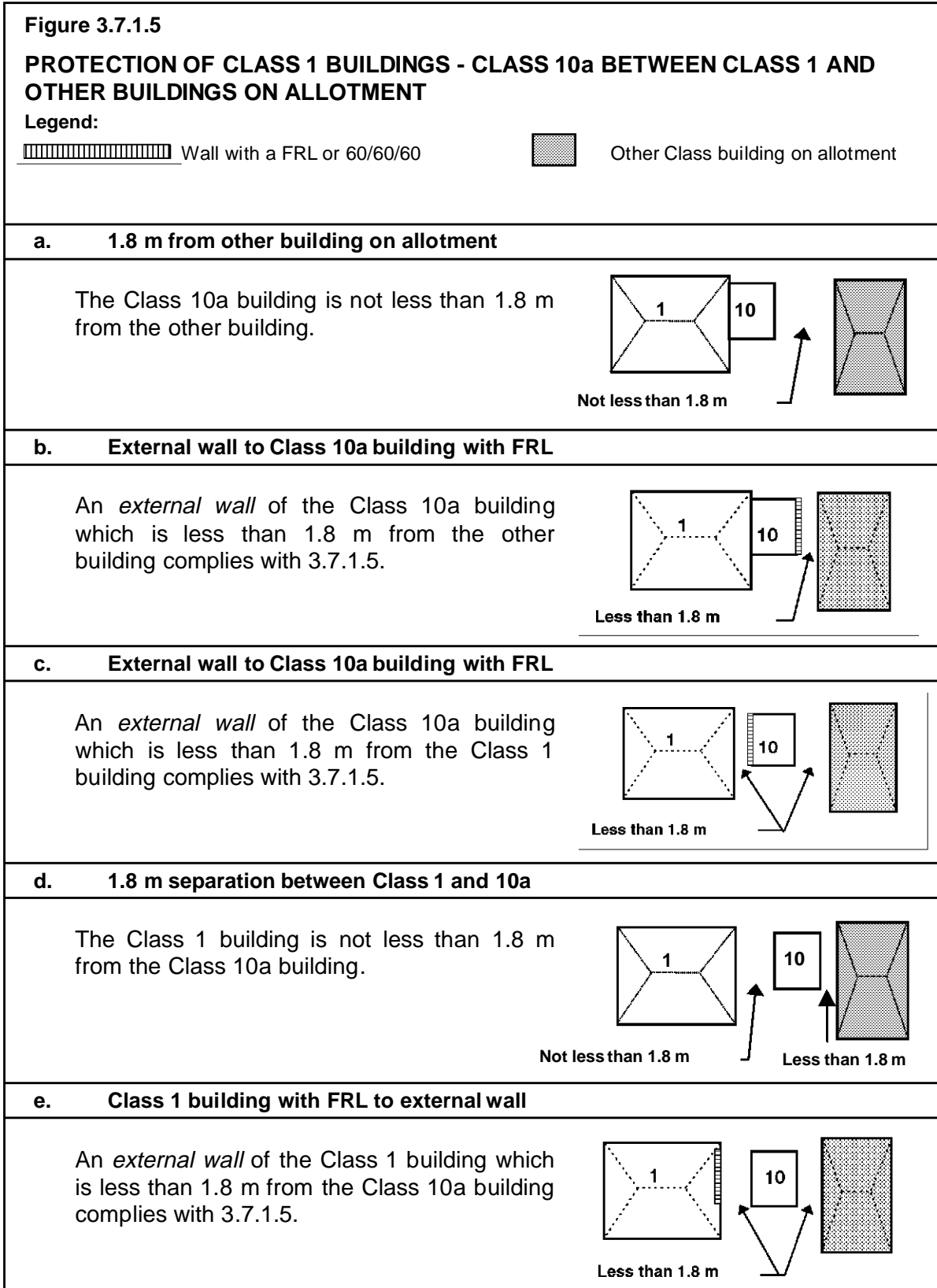

Figure 3.7.1.6

PROTECTION OF CLASS 1 BUILDINGS - SEPARATION OF CLASS 10a BUILDINGS ON AN ALLOTMENT

Legend:  Wall with a FRL or 60/60/60

a. 1.8 m between Class 10a buildings

Each 10a must be separated from each other by a distance of not less than 1.8 m.

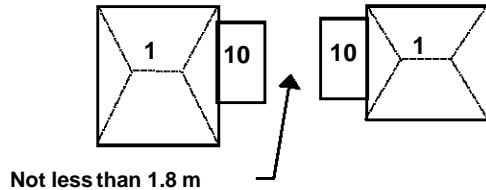

b. External wall to Class 10a building with FRL

Each 10a must be separated from each other by *external walls* complying with 3.7.1.5.

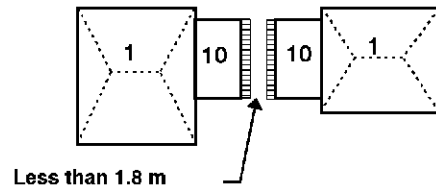

c. 900 mm separation between Class 10a and Class 1 buildings

Each 10a must be separated from each Class 1 building by a distance of not less than 900 mm.

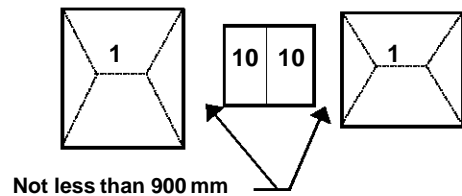

d. External wall to Class 10a buildings with FRL

Each 10a must be separated from each Class 1 building by *external walls* complying with 3.7.1.5.

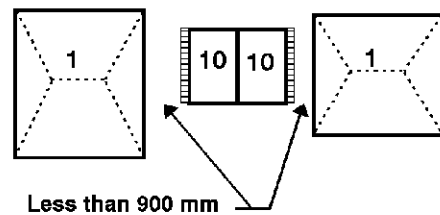

e. Class 10a buildings with FRL to separating wall

Each 10a must be separated by a wall complying with 3.7.1.5.

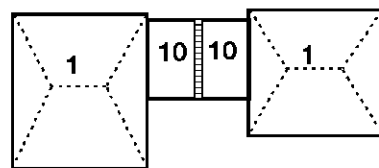

Amdt 3

- (d) A carport is exempt from (a), (b) and (c) if-
 - (i) it has two or more sides open and not less than one third of its perimeter open and, for the purposes of this clause, a side is considered to be open if the roof covering adjacent to that side is not less than 500 mm from another building or allotment boundary; and
 - (ii) it has a *non-combustible* roof covering and any ceiling lining and wall cladding, including gables, is also *non-combustible* (see Figure 3.7.1.7); and

Figure 3.7.1.7

IDENTIFYING AN OPEN CARPORT

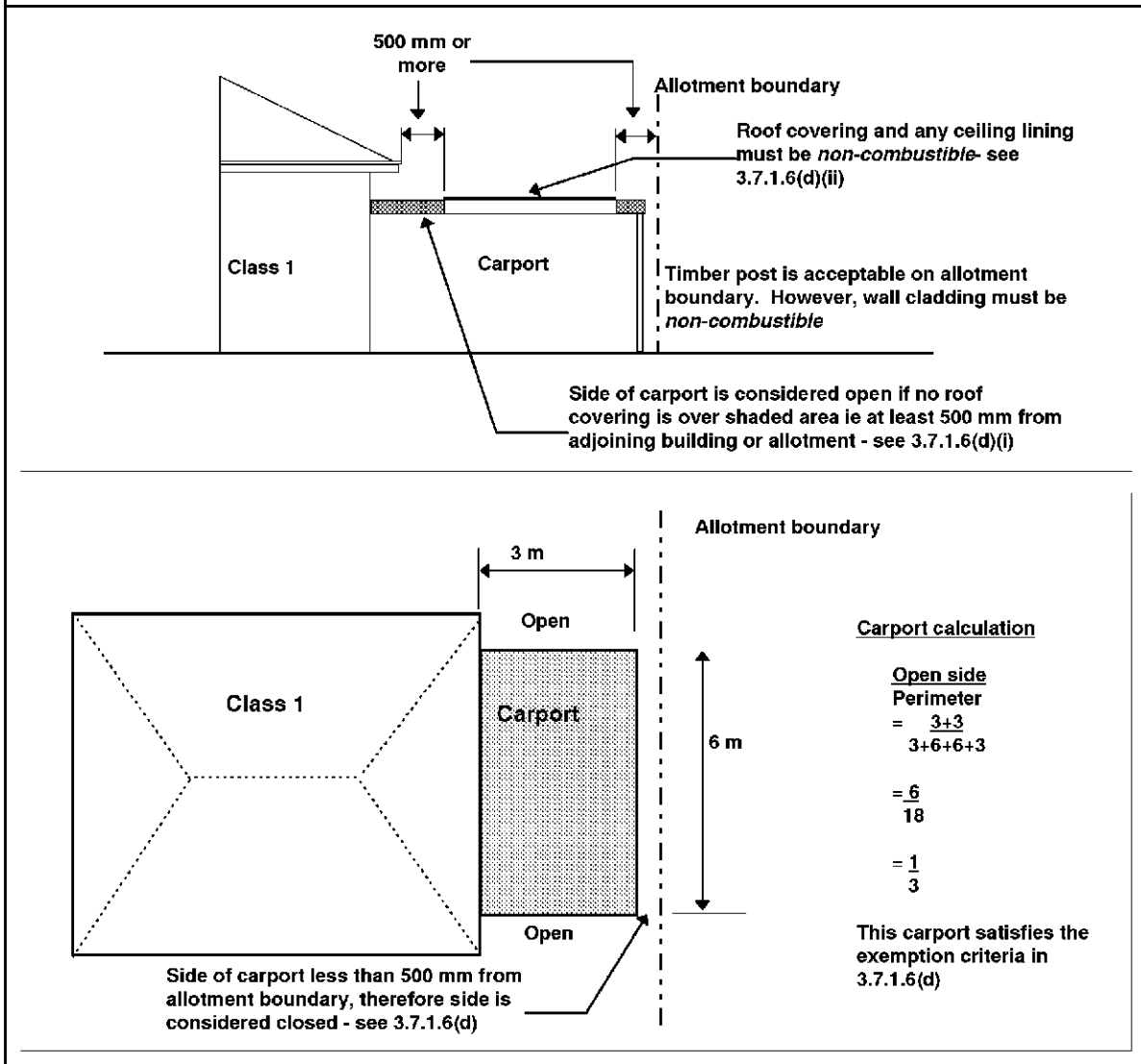

Amdt 3

- (iii) it does not provide direct vertical support to any part of the Class 1 building; and
- (iv) in the case where it has a common roof structure with the Class 1 building and the carport does not have a ceiling (see Figure 3.7.1.8), the opening between the top of the wall of the Class 1 building and the underside of the roof covering is infilled with-
 - (A) a *non-combustible* material; or
 - (B) construction clad with *non-combustible* material on the carport side.

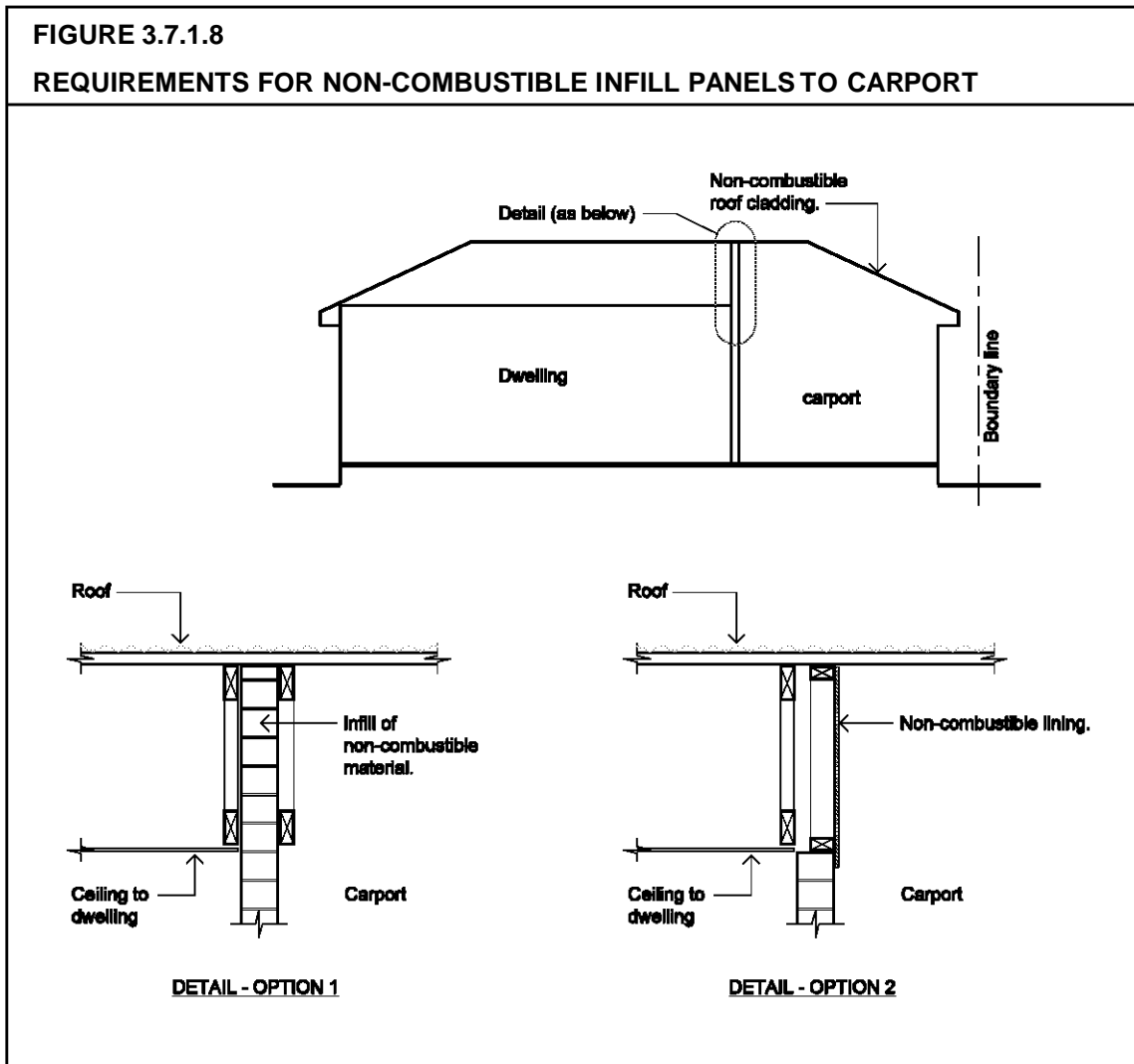

Amdt 3

- (e) Class 10a buildings must not significantly increase the risk of spread of fire between Class 2 to 9 buildings.

3.7.1.7 Allowable encroachments

- (a) An encroachment is any construction between the *external wall* of the building and the allotment boundary, or the *external walls* of two buildings on the same allotment and relates to any *external wall* of-
- (i) a Class 10a building required to comply with 3.7.1.5; or
 - (ii) a Class 1 building.
- (b) The encroachments allowed within 900 mm of an allotment boundary or within 1.8 m of another building on the same allotment are-
- (i) fascias, gutters, downpipes and the like; and
 - (ii) eaves with *non-combustible* roof cladding and *non-combustible* lining; and
 - (iii) flues, chimneys, pipes, domestic fuel tanks, cooling or heating appliances or other services; and
 - (iv) light fittings, electricity or gas meters, aerials or antennas; and
 - (v) pergolas or sun blinds; and
 - (vi) unroofed terraces, landings, steps and ramps, not more than 1 m in height.
- (c) Encroachments listed in (b)(i), if *combustible*, b(ii) and b(iii) must not be built within 450 mm of an allotment boundary nor be built within 900 mm of the *external wall* or associated encroachments of another building on the same allotment. (see Figure 3.7.1.9)

Figure 3.7.1.9
Amdt No. 3

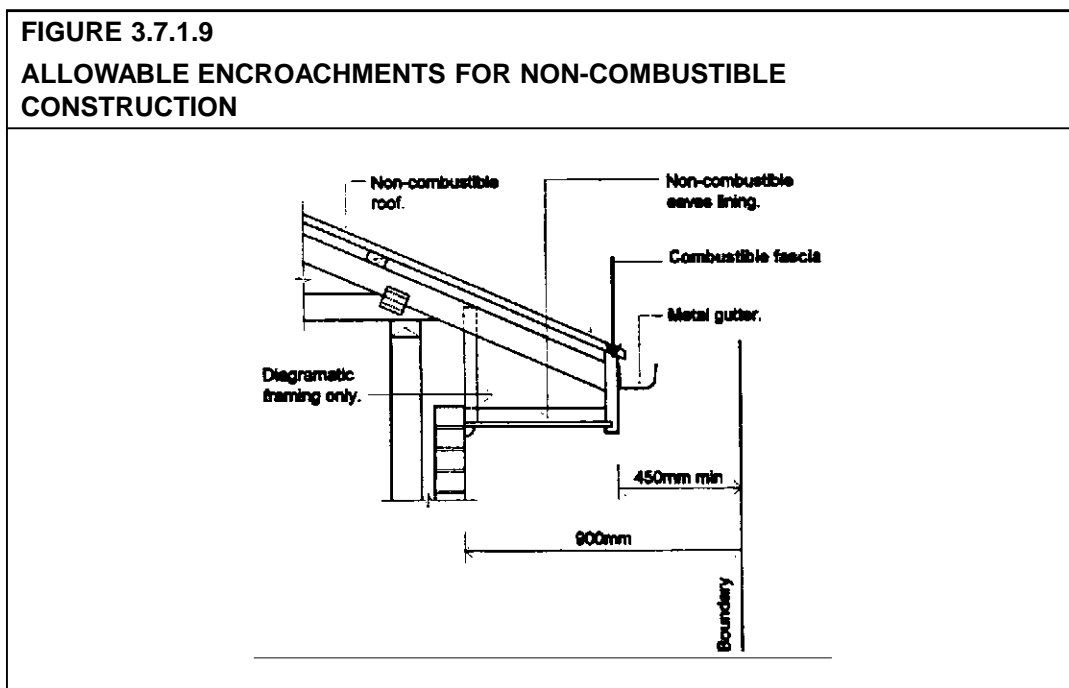

3.7.1.8 Separating walls

- (a) A wall that separates Class 1 dwellings, or separates a Class 1 building from a Class 10a building which is not appurtenant to that Class 1 building must have an FRL of not less than 60/60/60 and-
- (i) commence at the footings or ground slab (see Figure 3.7.1.10); and
 - (ii) extend-
 - (A) if the building has a *non-combustible* roof covering, to the underside of the roof covering (see Figure 3.7.1.10 and 3.7.1.11); or
 - (B) if the building has a *combustible* roof covering, to not less than 450 mm above the roof covering (see Figure 3.7.1.10).
- (b) A *separating wall* of *lightweight construction* must be tested in accordance with Specification C1.8 of the BCA Volume One.

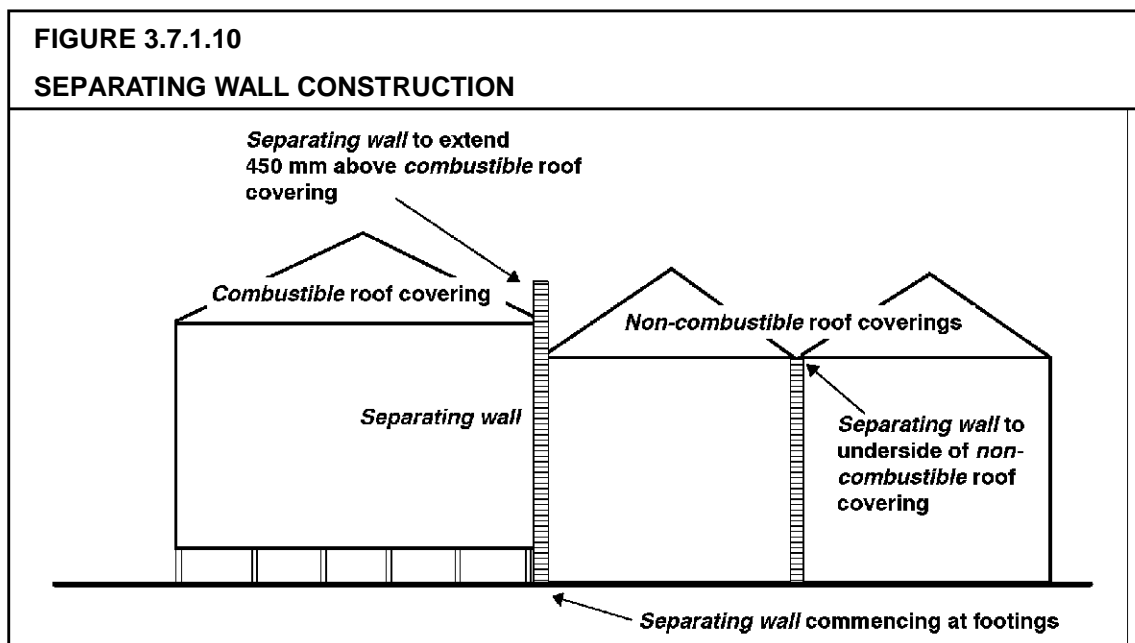

- (c) A *separating wall* complying with (a)(ii)(A)-
- (i) must not be crossed by timber or other *combustible* building elements except for roof battens with dimensions of not more than 75x50 mm; and
 - (ii) must have any gap between the top of the wall and the underside of the roof covering packed with mineral fibre or other suitable *fire-resisting* material.

- (d) Where a building has a masonry veneer *external wall*, any gap between the *separating wall* and the external masonry veneer must be-
- (i) not more than 50 mm; and
 - (ii) packed with a mineral fibre or other suitable *fire-resisting* material with the packing arranged to maintain any weatherproofing requirements of Part 3.3.4.

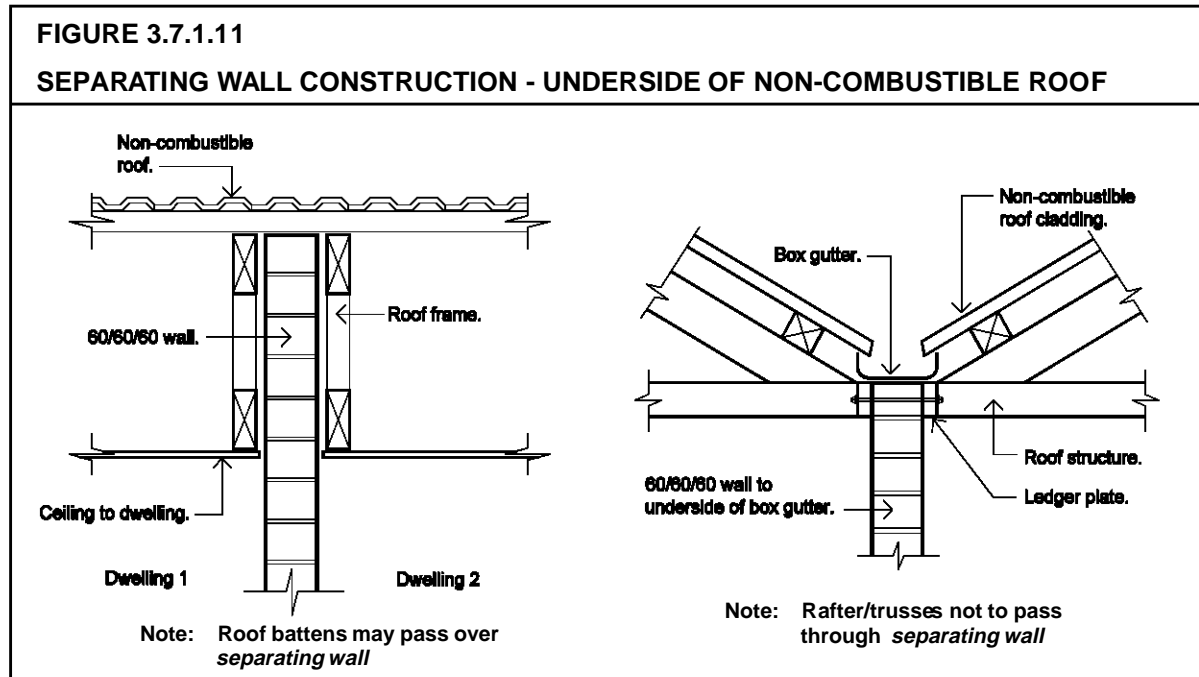

3.7.1.9 Sarking-type materials

Any *sarking-type material* used in the roof of a Class 1 building must have a *flammability Index* of not more than 5.

STATE AND TERRITORY VARIATIONS

3.7.1.9 is replaced as follows in Western Australia.

Any *sarking-type material* and such material used for flexible air ducts in a Class 1 building must have a *flammability index* of not more than 5.

3.7.1.10 Roof lights

Combustible roof lights, skylights or the like installed in a roof or part of a roof *required* to have a *non-combustible* covering must-

- (a) have an aggregate area not more than 20 % of the roof or part of the roof; and

- (b) be not less than-
 - (i) 900 mm from-
 - (A) the allotment boundary other than the boundary adjoining a road alignment or other public space; and
 - (B) the vertical projection of a *separating wall* extending to the underside of the roof covering; and
 - (ii) 1.8 m from any roof light or the like in another building on the allotment other than an appurtenant building or a detached part of the same building.
- (See Figure 3.7.1.12)

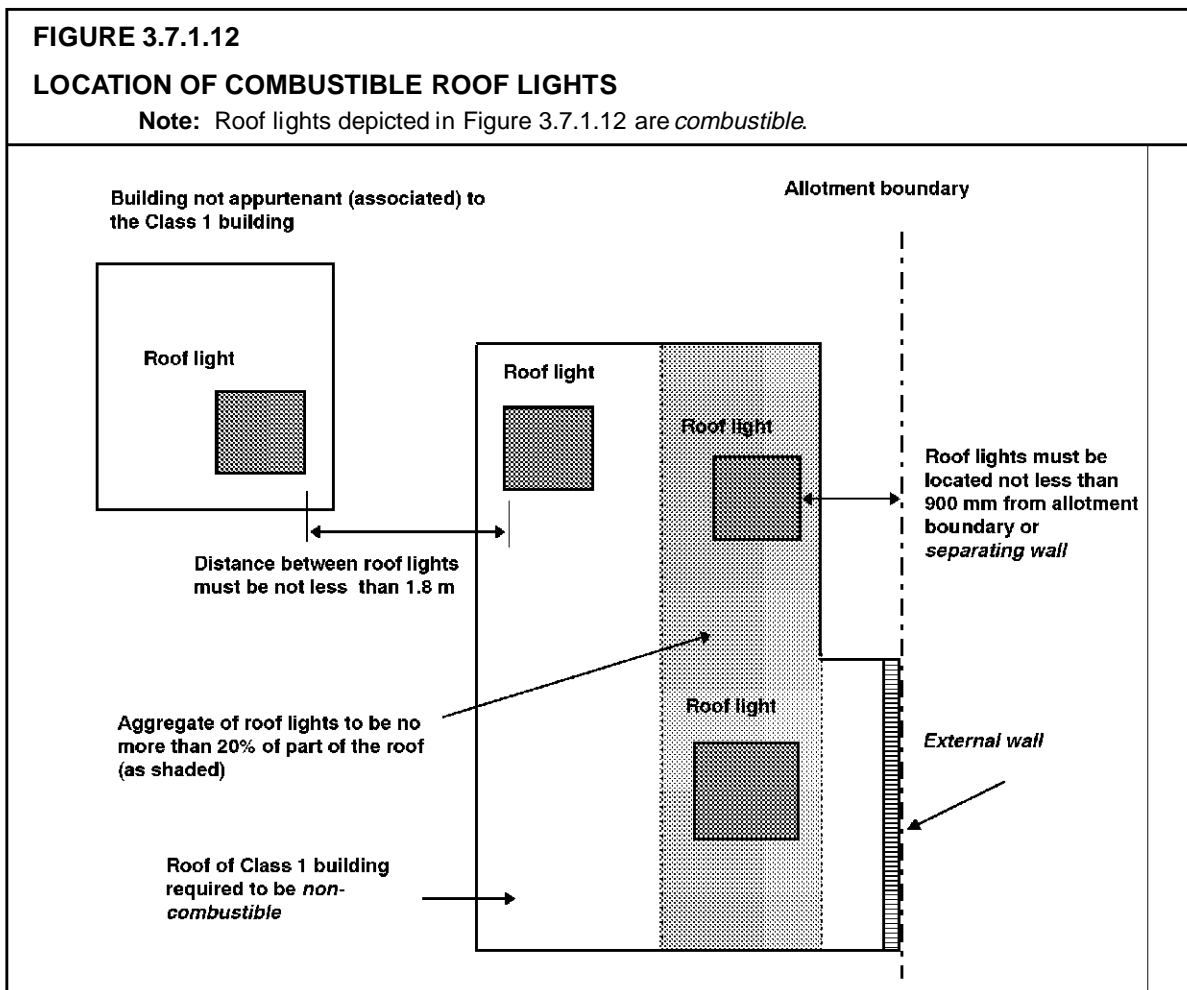

Amdt 3

PART 3.7.2 SMOKE ALARMS

Appropriate *Performance Requirements*

Where an alternative smoke alarm system is proposed to that described in Part 3.7.2, that proposal must comply with *Performance Requirement P2.3.2* in Section 2.

Acceptable construction practice

3.7.2.1 Application

Compliance with this Part satisfies *Performance Requirement P2.3.2* for smoke alarms.

3.7.2.2 Requirements for smoke alarms

3.7.2.2
Amdt No. 3

- (a) Smoke alarms must be installed in-
 - (i) Class 1a buildings in accordance with 3.7.2.3; and
 - (ii) Class 1b buildings in accordance with 3.7.2.4 and 3.7.2.5.
- (b) Smoke alarms must comply with AS 3786.
- (c) Smoke alarms must be connected to the consumer mains power where consumer power is supplied to the building.

3.7.2.3 Location - Class 1a buildings

Smoke alarms must be installed in a Class 1a building on or near the ceiling in-

- (a) any storey containing bedrooms-
 - (i) between each part of the dwelling containing bedrooms and the remainder of the dwelling; and
 - (ii) where bedrooms are served by a hallway, in that hallway; and
 - (b) any other storey not containing bedrooms.
- (see Figure 3.7.2.1, Diagram a and Figure 3.7.2.2)

3.7.2.4 Location - Class 1b buildings

3.7.2.4
Amdt No. 3

In a Class 1b building, smoke alarms must be installed on or near the ceiling-

- (a) in every bedroom and
 - (b) in every corridor or hallway associated with a bedroom, or if there is no corridor or hallway, in an area between the bedrooms and the remainder of the building; and
 - (c) on each other storey.
- (see Figure 3.7.2.1, Diagram b and Figure 3.7.2.2)

3.7.2.5 Lighting to assist evacuation – Class 1b buildings

3.7.2.5
Amdt No. 3

In a Class 1b building, a system of lighting must be installed to assist evacuation of occupants in the event of a fire, and-

- (a) be activated by the smoke alarm *required* by 3.7.2.4(b); and
- (b) consist of-
 - (i) a light incorporated within the smoke alarm; or
 - (ii) the lighting located in the corridor, hallway or area served by the smoke alarm.

Explanatory Information:

Figure
3.7.2.1
Amdt No. 3

The lighting required by 3.7.2.5 may consist of the artificial lighting which may already be installed in a corridor, hallway or area, provided that lighting is activated by the smoke alarm.

Amdt 3

FIGURE 3.7.2.1

LOCATION OF SMOKE ALARM

Legend: ● Smoke alarm ◻ Smoke alarm with evacuation lighting (as required by 3.7.2.5(b)(i))

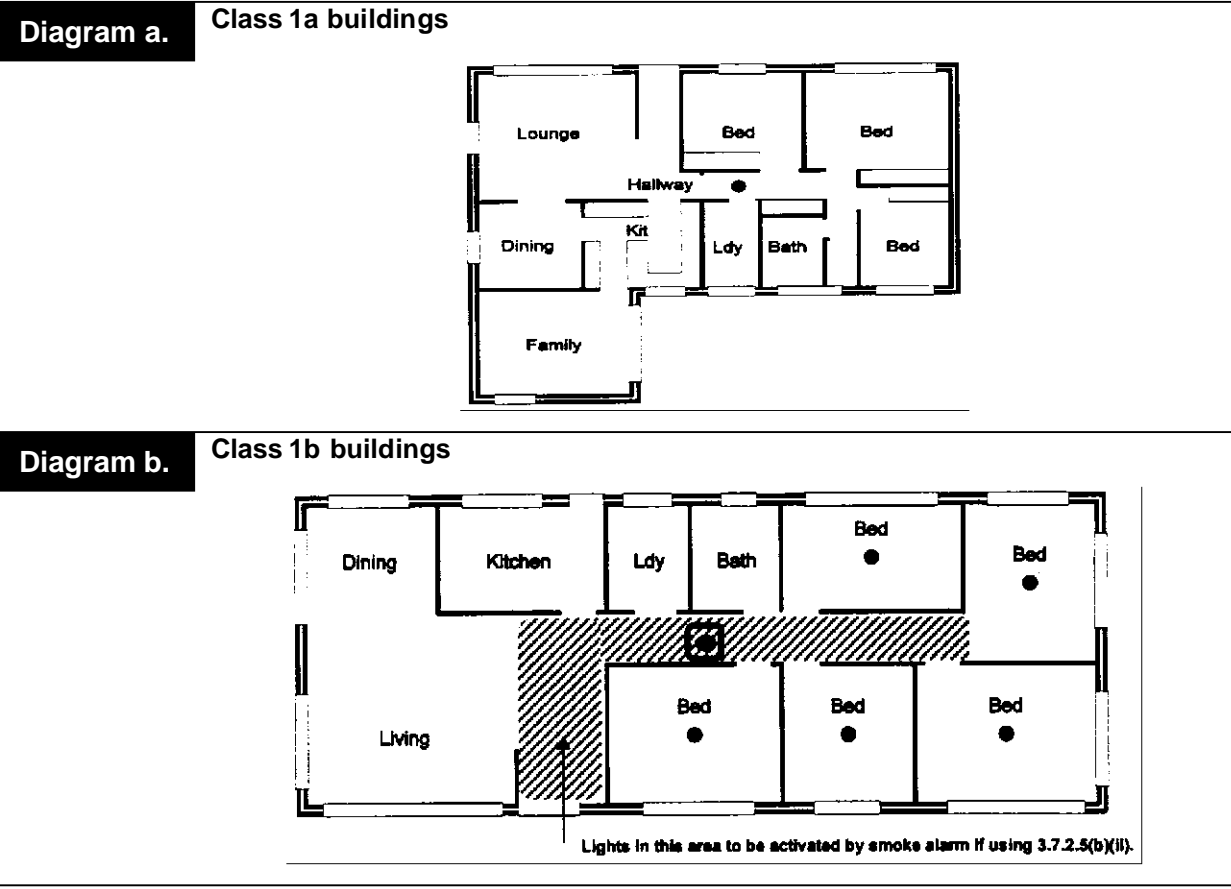
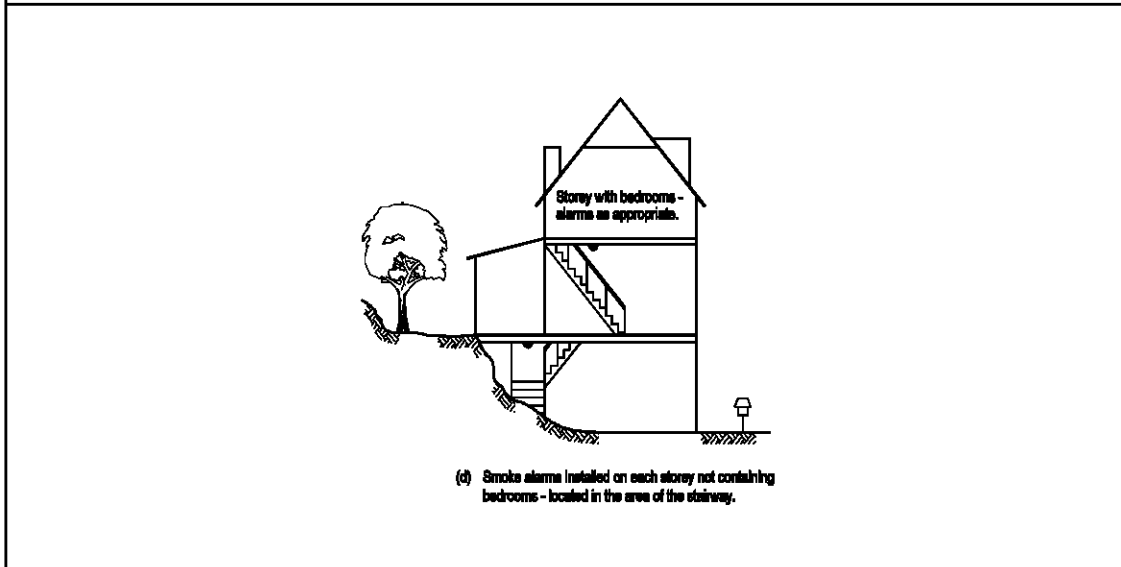

FIGURE 3.7.2.2

LOCATION OF SMOKE ALARMS ON DIFFERENT STOREYS

**Explanatory Information:****1. HOW DOES A SMOKE ALARM WORK ?**

There are two types of smoke alarms.

1.1 Photoelectric: This type of smoke alarm uses a light source and photocell. As the smoke enters the detection chamber it interferes with the light beam which in turn causes the alarm to sound.

1.2 Ionisation: A small amount of radioactive material is used to create an electrical current which travels through ionised air. When smoke enters the detection chamber it impedes the flow of current and causes the alarm to sound.

2. LOCATION OF SMOKE ALARMS

When deciding on the position of smoke alarms it is important to remember that they are intended to detect smoke before it reaches the sleeping occupants of a building.

The ensuing alarm is designed to wake the occupants and give them time to evacuate the building.

2.1 Added flexibility when considering detector location

As mentioned earlier, the introduction of the *Performance Requirement* gives the *appropriate authority* flexibility when considering the location of smoke alarms.

For instance, in Class 1a buildings if the *Deemed-to-Satisfy Provision* states that the smoke alarm should be located in the hallway, and there is a bathroom adjacent this location (that will potentially cause nuisance alarms) the *appropriate authority* could accept the alarm being installed in the bedroom as a suitable option using the performance clause.

Explanatory information (cont):

This approach should also be adopted when considering sleep-outs or similar type residential buildings that are not connected to the remainder of the building by a hallway or other enclosed structure. In these situations the alarm could be located in the room itself.

2.2 Protection of sleeping areas in Class 1a buildings

2.2
Amdt No. 2

The deemed-to-satisfy provisions require that a smoke alarm be located "between each area containing bedrooms and the remainder of the dwelling".

In some dwellings the bedrooms are located in a common area and connected by a hallway. In this instance the alarm should be located as shown in Figure 3.7.2.1, diagram a.

2.3 Location of the smoke alarm on other storeys

2.3
Amdt No. 2

A smoke alarm is also required on each other storey that is not already provided with a smoke alarm. It should be noted that smoke alarms are required to be installed in other storeys even if those storeys consist of only carparking, bathrooms, laundries and the like. "Storey" in this context differs from the definition contained in BCA96 Volume One which excludes such spaces from being considered as storeys.

The favoured location for this alarm will be in the path of travel people will most likely take to evacuate the building. This will ensure an alarm will be raised before smoke makes the common exit path impassable.

eg If the bedrooms are on the first floor, then an alarm should be positioned near the area of the inter connecting stair at ground level.

If the other storey is not connected to the remainder of the building (for instance a ground floor garage) then the alarm should be centrally located in the lower area. However, it may be reasonable, using a performance approach, not to install smoke alarms where the storey is predominantly open, such as the basement level of a highset house on stumps that is used for carparking or laundry purposes.

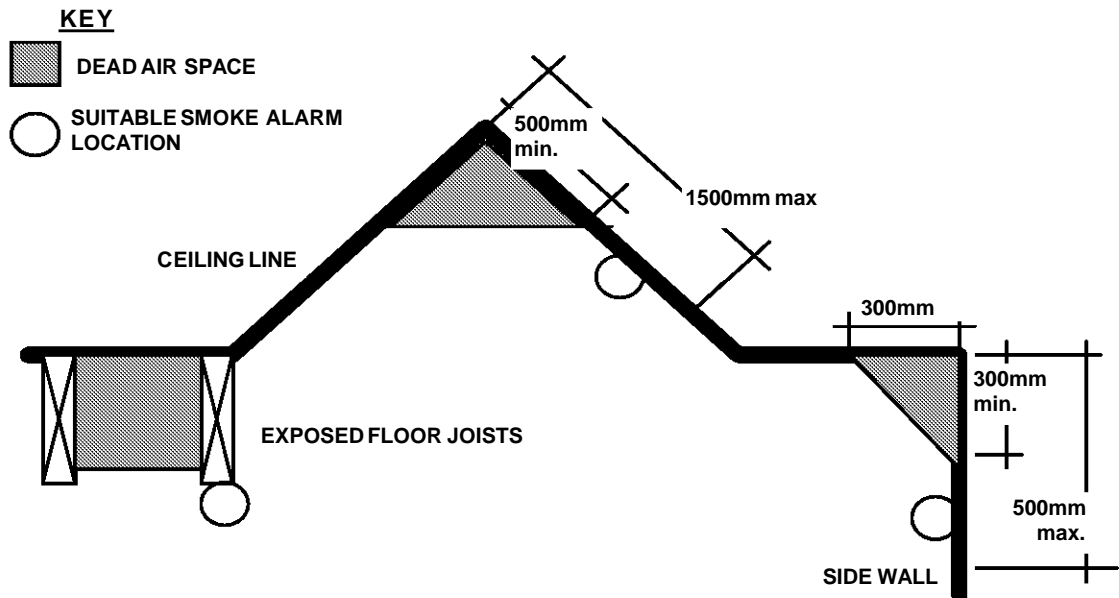

DIAGRAM 1 - DEAD AIR SPACE AND PROPER MOUNTING OF SMOKE ALARMS ON SIDE WALLS

Amdt 3

Explanatory information (cont):**2.4 Installation of smoke alarms**

Smoke alarms should be installed on or near the ceiling with special care being taken to avoid dead air spaces.

A dead air space is an area in which trapped hot air will prevent smoke from reaching the alarm. This space generally occurs at the apex of cathedral ceilings, the corner junction of walls and ceilings, between exposed floor joists etc (See Diagram 1).

If it is impractical to mount the smoke alarm on the ceiling then it may be located on the wall. The recommended position is between 300 mm and 500 mm off the ceiling (See Diagram 1).

The distance from the apex of a cathedral ceiling to the top of the alarm should be between 500 and 1500 mm.

3. NUISANCE ALARMS

Smoke alarms are extremely sensitive and may detect smoke and moisture created by common household activities (such as burnt toast or steam from a bathroom).

Accordingly, to reduce the likelihood of nuisance alarms, the smoke alarm should not be located near cooking appliances and bathrooms. However if it is necessary to locate alarms in these positions, an ionisation type alarm is more suitable near bathrooms, while a photoelectric alarm may be used near cooking appliances.

4. INTERCONNECTION OF SMOKE ALARMS

Some types of alarm are capable of interconnection to the other alarms so that if one alarm sounds then the other alarms are also activated adding an enhanced level of safety. There is no requirement in the BCA that smoke alarms be interconnected.

PART 3.7.3 HEATING APPLIANCES

Appropriate *Performance Requirements*:

Where an alternative heating appliance is proposed to that described in Part 3.7.3, that proposal must comply with *Performance Requirement* P2.3.3 in Section 2.

A. Acceptable construction manuals

3.7.3.0 *Performance Requirement* P2.3.3 is satisfied for a heating appliance if it is installed in accordance with one of the following manuals:

- (a) Domestic oil-fired appliances are installed in accordance with AS 1691.
- (b) Domestic solid-fuel burning appliances are installed in accordance with AS 2918.
- (c) Boilers and pressure vessels are installed in accordance with AS 1200.

B. Acceptable construction practice

3.7.3.1 Application

Compliance with this Part satisfies *Performance Requirement* P2.3.3 for heating appliances.

3.7.3.2 Open fireplace construction

An open fireplace must be constructed as follows (also see Figure 3.7.3.1):

- (a) All masonry must be constructed in accordance with Part 3.3.
- (b) The front hearth must be constructed of stone, concrete, masonry or similar material so that-
 - (i) it extends not less than 300 mm beyond the front of the fireplace opening and not less than 150 mm beyond each side of that opening; and
 - (ii) its upper surface does not slope away from the back hearth.
- (c) The base of the back hearth must be constructed of stone, concrete, masonry or similar material and any *combustible* flooring or framing members must be situated not less than 150 mm from its upper surface.
- (d) The fireplace rear and side walls up to a height of 300 mm above the underside of the arch or lintel-
 - (i) must be constructed in 2 separate leaves of solid masonry with an overall thickness not less than 180 mm thick, excluding any *cavity*; and
 - (ii) must not consist of concrete block masonry in the construction of the inner leaf; and

- (iii) must be constructed of masonry units with a net volume, excluding cored and similar holes, not less than 75% of their gross volume, measured on the overall rectangular shape of the units, and with an actual thickness of not less than 100 mm.
- (e) The fireplace must be constructed on footings complying with 3.2.5.5.

Figure 3.7.3.1

FIRE PLACE CLEARANCE FROM COMBUSTIBLE MATERIALS

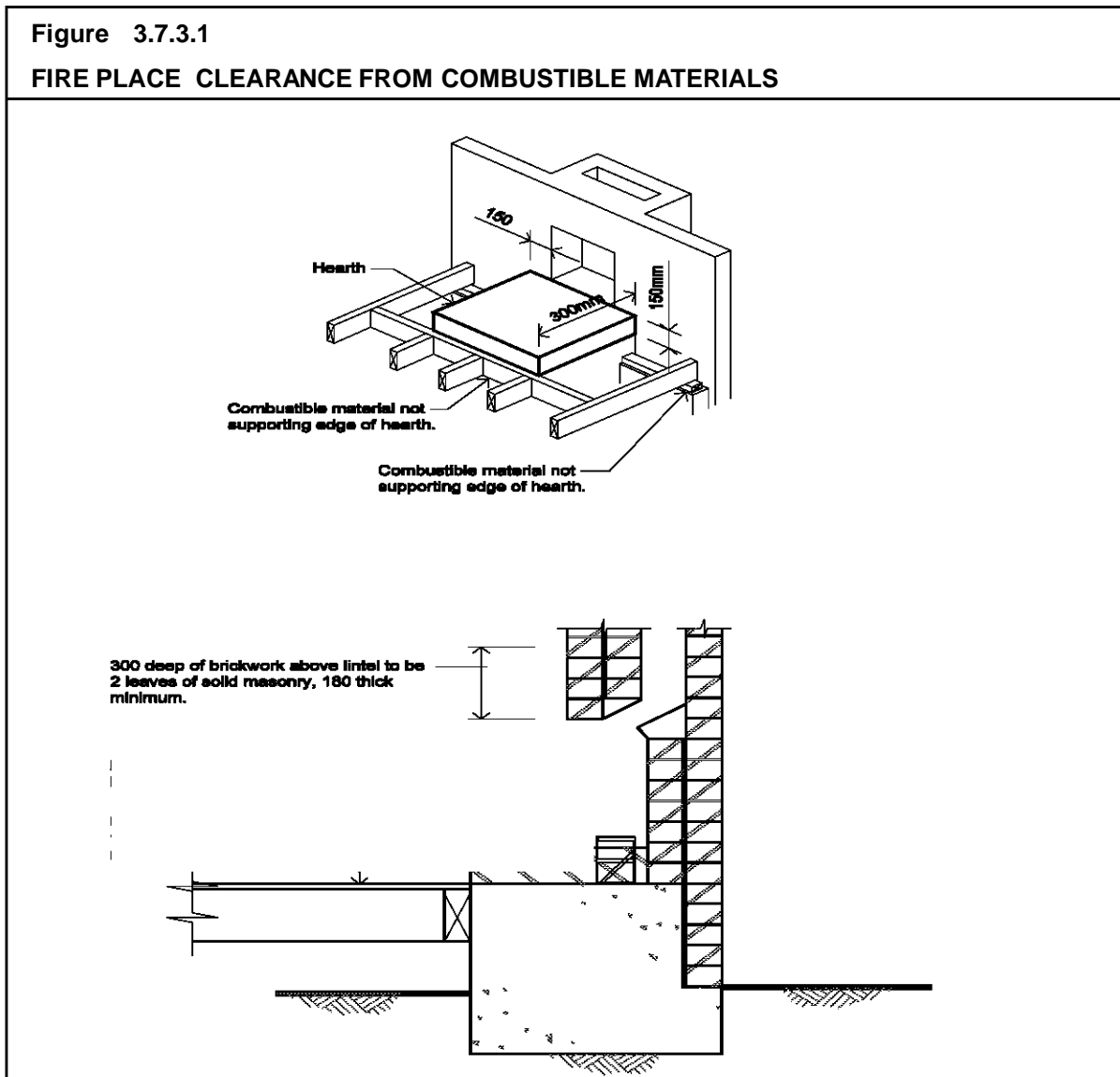

Amdt 3

3.7.3.3 Chimney construction

The construction of a chimney must comply with Part 3.3 and the following:

- (a) The walls of the chimney above the level referred to in 3.7.3.2 (d) must be lined internally to a thickness of not less than 10 mm with composition mortar parging.
- (b) The chimney or flue must terminate not less than 300 mm above the highest part of the building within a horizontal distance of 3.6 m of the chimney or (see Figure 3.7.3.2).

3.7.3.3(b)
Amdt No. 3

Fig 3.7.3.2
Amdt No. 3

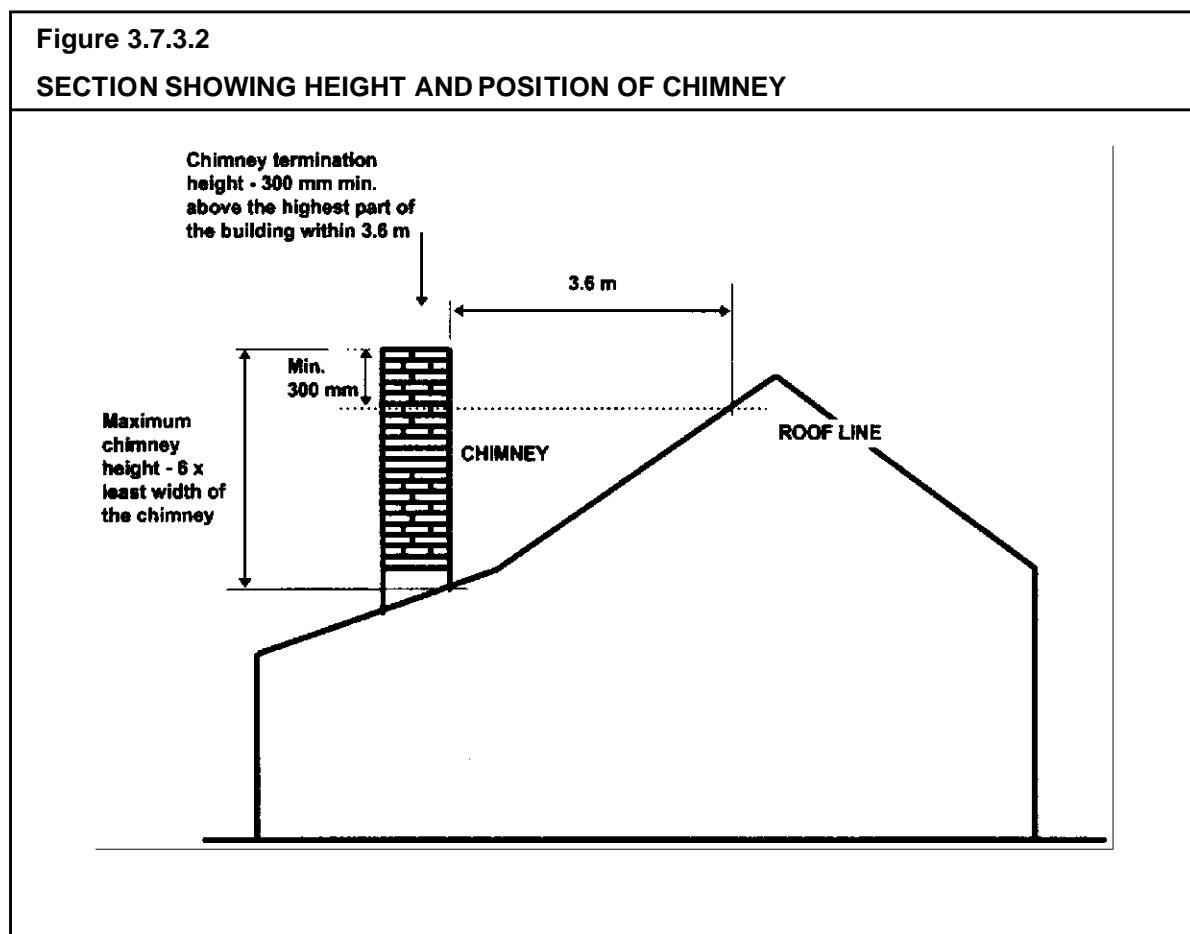

3.7.3.4 Installation of insert fireplaces and flues

An insert fireplace and flue must comply with the following:

- (a) The insert fireplace must be tested and passed the tests required by AS 2918.
- (b) The insert fireplace must be fitted into a masonry fireplace (including chimney) constructed in accordance with Part 3.3.
- (c) The flue must be-

- (i) double skin and have been tested and pass the tests required by AS 2918; or
- (ii) cast iron, cellulose fibre reinforced cement not less than 9.5 mm thick, galvanised steel not less than 1.2 mm thick or such other material of at least equivalent strength and durability, installed in accordance with Section 6 of AS 1691, as though it is a flue connected to an oil heating appliance.

Figure 3.7.3.3
TYPICAL INSTALLATION OF FIRE PLACE FLUE INSERTS

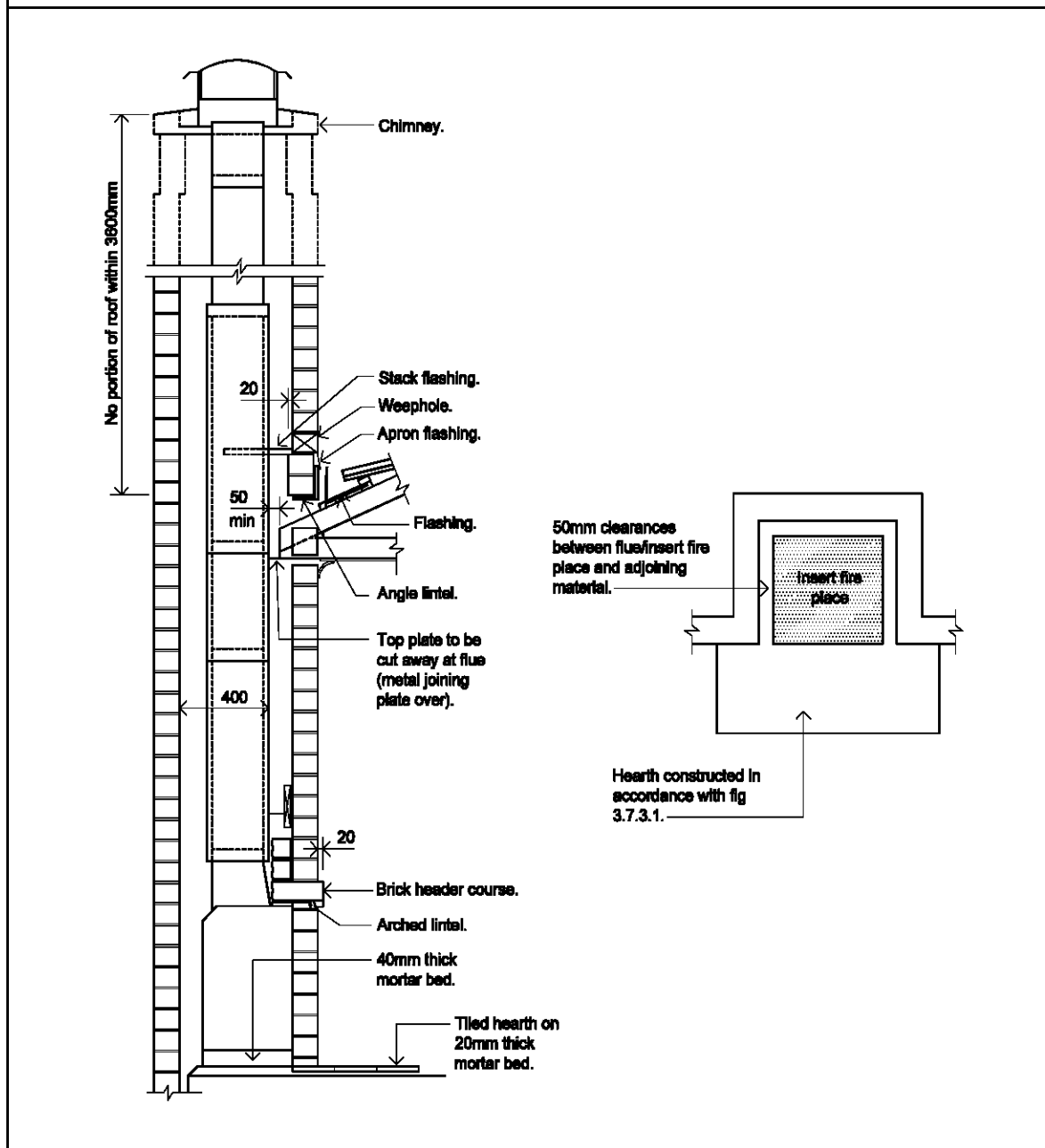

- (d) There must be a clearance of not less than 50 mm between the outer flue and adjacent materials.
- (e) The flue must terminate in accordance with Figure 3.7.3.2.
- (f) The hearth must be constructed in accordance with 3.7.3.2 (b), (c) and (e).

3.7.3.5 Installation of free standing heating appliances

The installation of a free standing heating appliance must comply with the following:

3.7.3.5(a)
Amdt No. 2

- (a) The appliance must-
 - (i) be installed with safety clearances determined by testing in accordance with AS 2918; or
 - (ii) be located not less than 1.2 m from adjoining walls (other than a masonry wall); or
 - (iii) have a heat shield between the adjoining wall (other than a masonry wall) and the heating appliance in accordance with Figure 3.7.3.4.
- (b) Where a heat shield is used, it must be installed in accordance with Figure 3.7.3.4 and it must be not less than 90 mm thick masonry constructed in accordance with Part 3.3.
- (c) The heating appliance must be installed on a hearth-
 - (i) complying with 3.7.3.2(b) and (c), except that the hearth must extend 400 mm from the appliance in accordance with Figure 3.7.3.4; or
 - (ii) where a heat shield is installed, in accordance with Figure 3.7.3.4.
- (d) The flue must-
 - (i) have been tested and passed the tests required by AS 2918; and
 - (ii) be installed in accordance with Figure 3.7.3.5; and
 - (iii) terminate in accordance with Figure 3.7.3.2.
- (e) Flue types or installation of flues in areas not specifically covered by Figures 3.7.3.4 and 3.7.3.5 must be installed in accordance with AS 2918.

Figure 3.7.3.4

ACCEPTABLE LOCATION OF FREE STANDING HEATING APPLIANCES

Diagram a.

ELEVATION

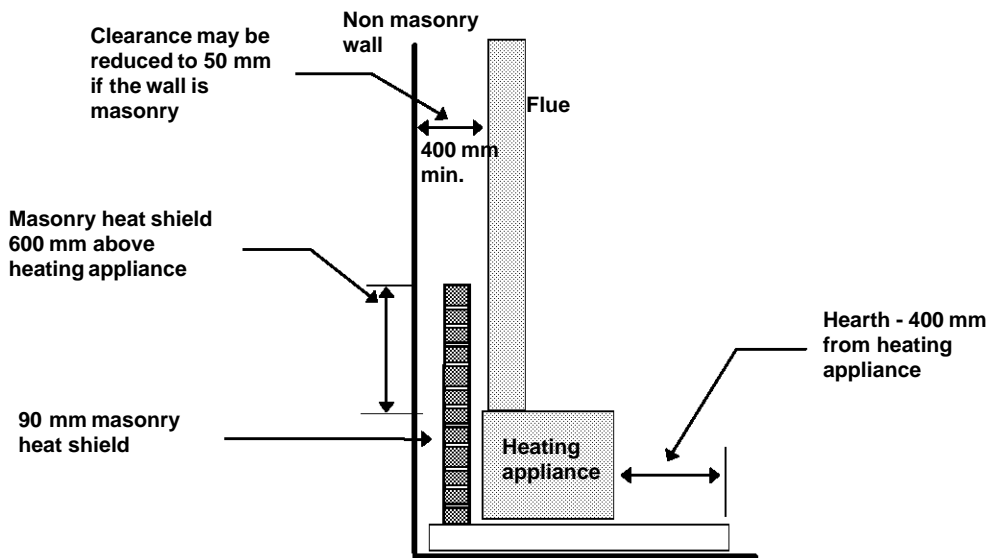
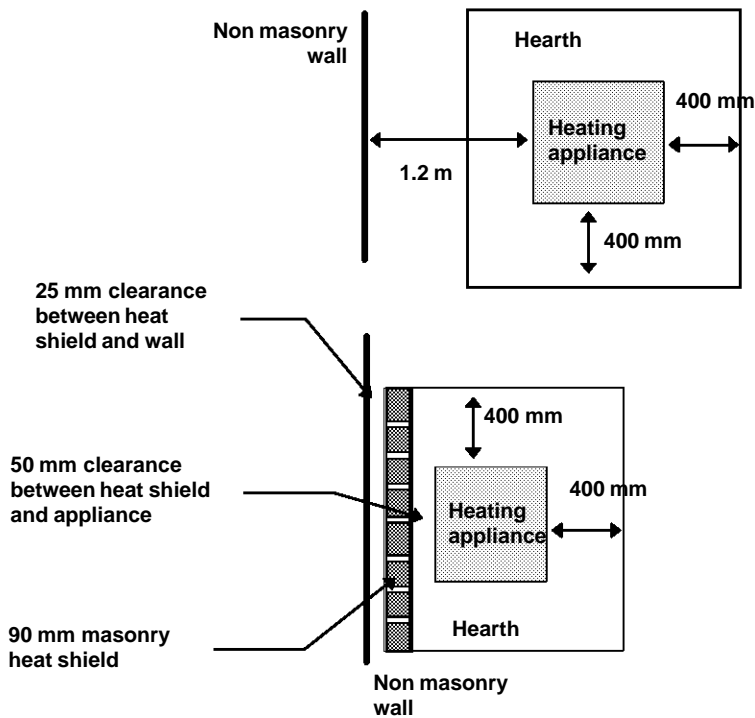

Diagram b.

PLAN VIEW



Amdt 3

Figure 3.7.3.5
ACCEPTABLE FLUE INSTALLATION DETAILS

Note: Flue pipe size - 150 mm maximum (for other sizes see AS 2918)

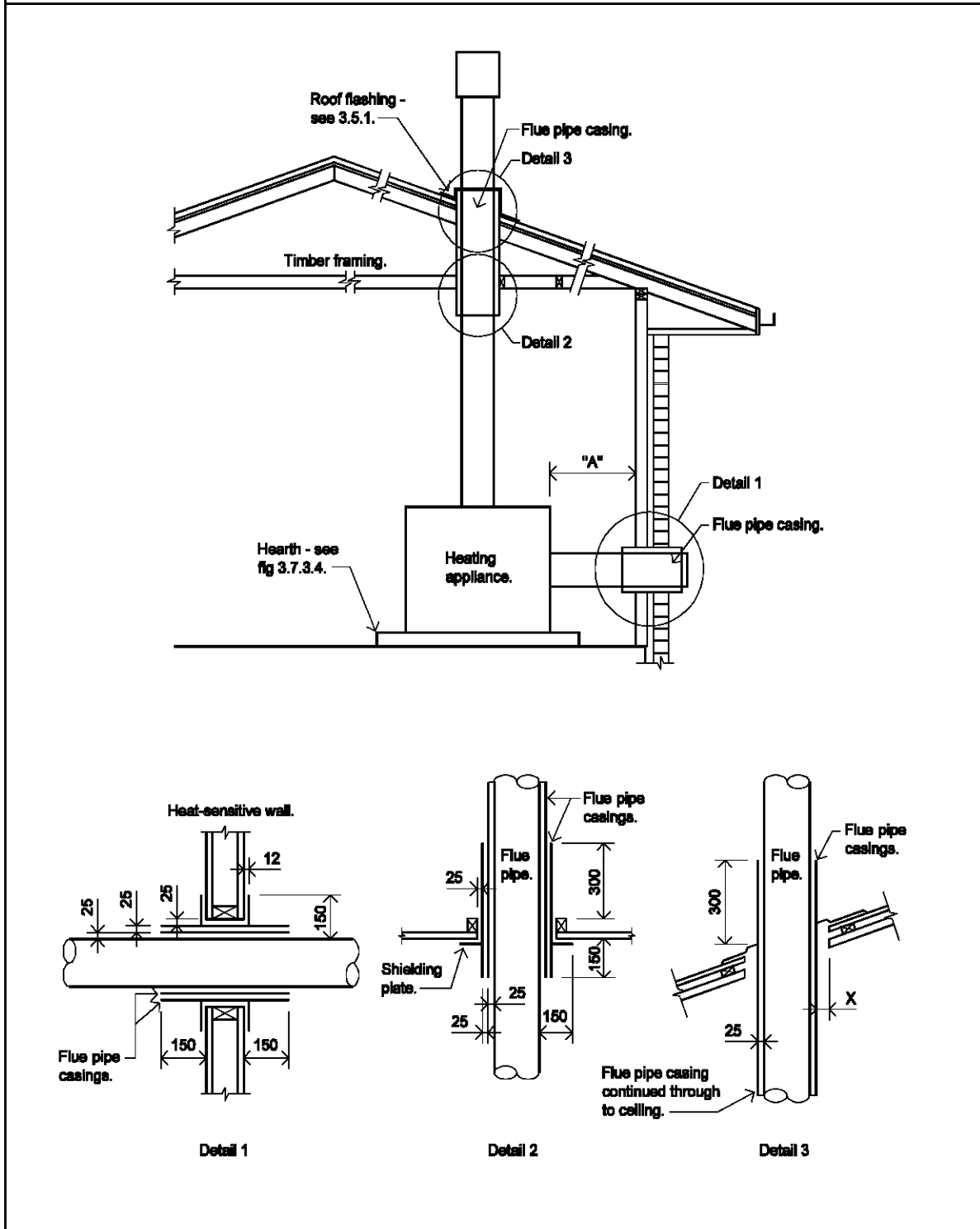

Amdt 3

PART 3.7.4 BUSHFIRE AREAS

Appropriate *Performance Requirements*:

Where an alternative bushfire protection design is proposed to that described in Part 3.7.4, that proposal must comply with *Performance Requirement P2.3.4* in Section 2.

A. Acceptable construction manuals

- 3.7.4.0** *Performance Requirement P2.3.4* is satisfied for a Class 1 building located in a *designated bushfire prone area* as defined under relevant State and Territory legislation, if it is constructed in accordance with AS 3959 - Construction of buildings in bushfire prone areas.

STATE AND TERRITORY VARIATIONS

3.7.4.0 is replaced by the following clause in South Australia

Performance Requirement P2.3.4 is satisfied for a Class 1 building located in a *designated bushfire prone area* as defined under relevant State and Territory legislation, if it is constructed in accordance with South Australian Minister's Specification SA G5 101.

B. Acceptable construction practice

3.7.4.1 Application

Compliance with this Part for Class 1 buildings constructed in *designated bushfire prone areas* satisfies *performance requirement P2.3.4*.

3.7.4.2 Bushfire protection

Protection measures against the danger of bushfires must prevent the entry of burning debris to the underfloor area, through wall penetrations such as *windows*, doors and vents and gaps in eaves and roof coverings by-

- (a) protecting the underfloor area and lower portion of the wall by closing off the space with *non-combustible*, weather resistant materials (see Figure 3.7.4.2); and
- (b) installing metallic and corrosion-resistant screens to doors, sub floor vents and operable sashes and louvres in *windows*; and
- (c) installing *non-combustible* roofing and fire retardant sarking (see Figure 3.7.4.1); and
- (d) fully enclosing the underside of eaves.

3.7.4.2(b)
Amdt No. 2

Figure 3.7.4.1

BUSHFIRE PROTECTION MEASURES

Diagram a. Protection of Ridge for Sheet Roofs

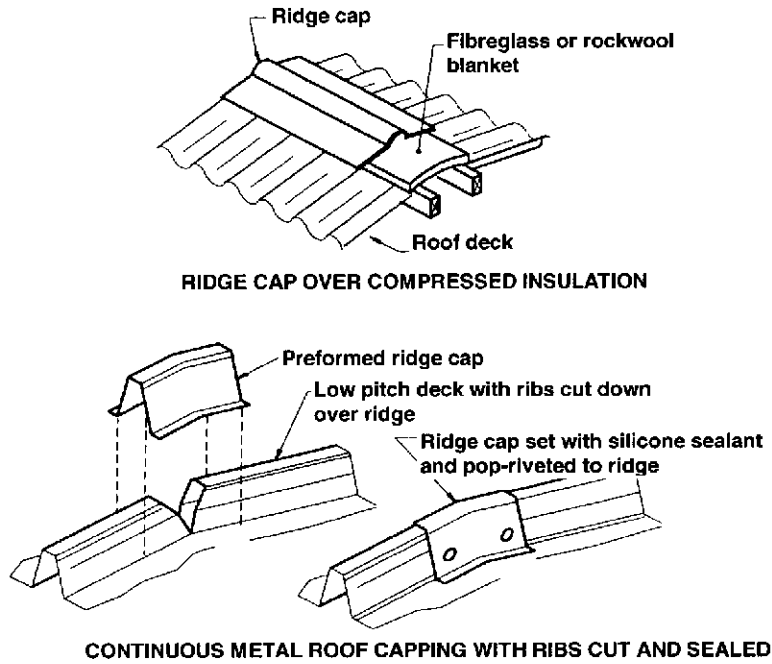
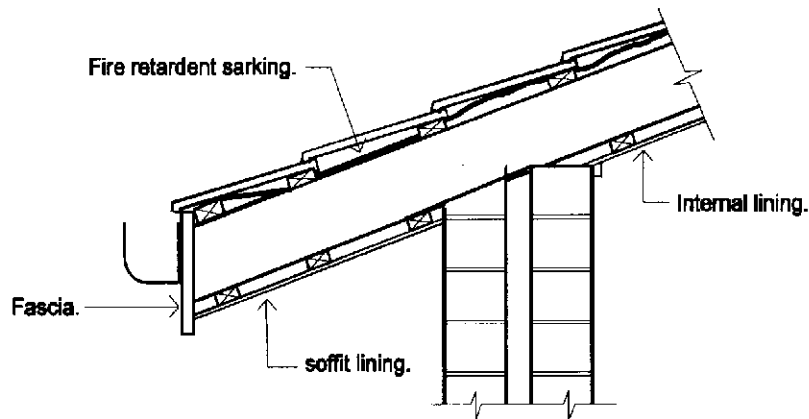
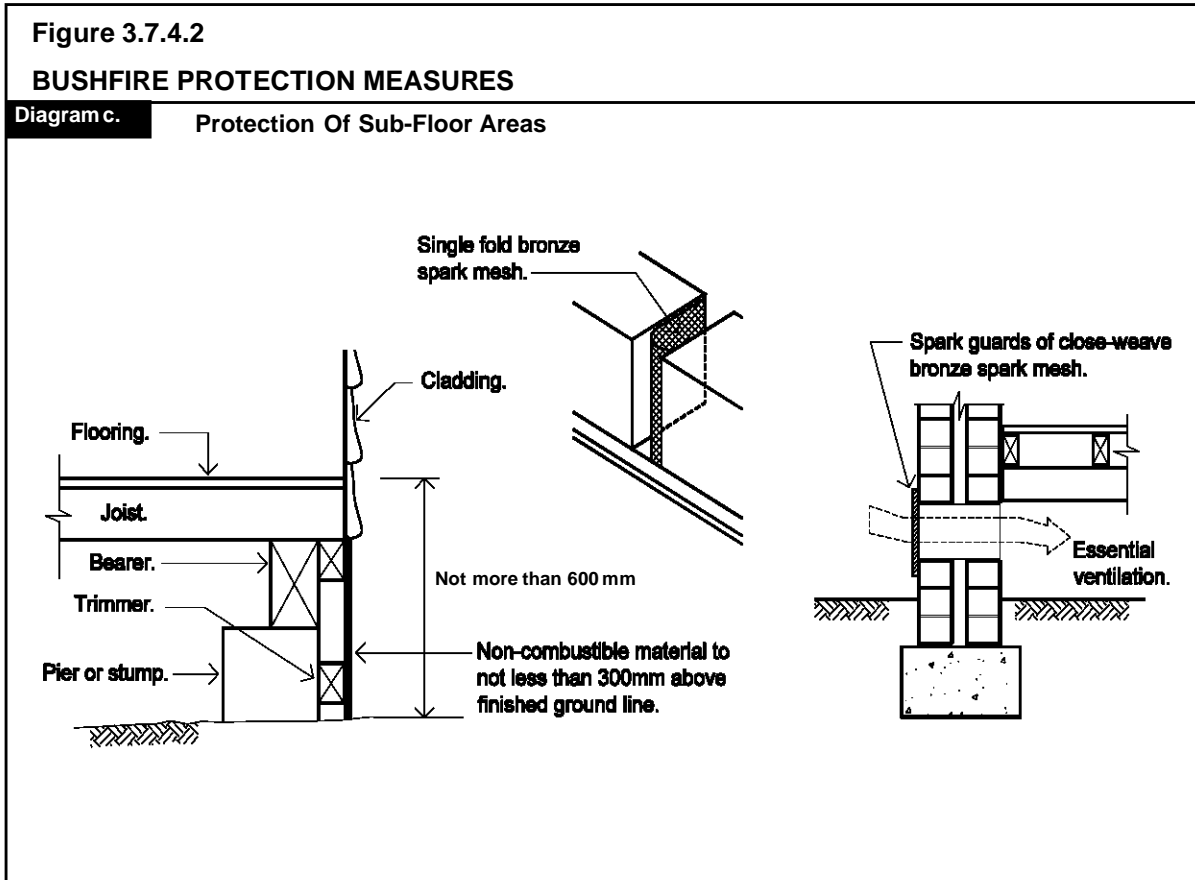

Diagram b. Protection of Eaves



Note: Fire retardant sarking is sarking with a maximum flammability index of 5 (see AS 1530.2)



Amdt 3

Explanatory information:

Care should be taken to ensure that the measures used to protect the sub-floor area do not compromise the effectiveness of any termite barrier system.

The provisions of this Part are applicable to Class 1 buildings constructed on land that has been declared under appropriate State and Territory legislation to be prone to danger from bushfires.

In South Australia schedule 18 of the Regulations under the SA Development Act 1993 sets out bush fire risk areas of the Mount Lofty Ranges that have been declared *designated bushfire-prone areas* for the purpose of the BCA. The protection methods must comply with the requirements of the Minister's Specification SA G5 101.

In Victoria, Building Regulation 6.4 under the Building Act provides that a Council after consultation with the Chief Officer may determine that all or part of the municipal district is a *designated bushfire prone area* for the purpose of the BCA. Information about the designation of any area would be available from the relevant local authority administration and the fire brigade.

In Queensland bushfire prone areas may be declared under Local Government's planning schemes. Bushfire risks are to be taken into account for standards for residential development in such areas.

Further technical information about bushfire protection is available from Standards Australia in SAA Hand Book HB 36 "Building in bushfire-prone areas" and CSIRO National Building Technology Centre Notes on the Science of Building NSB 154 "Houses exposed to bushfires".

PART 3.7.5 ALPINE AREAS

Appropriate *Performance Requirements*:

Where an alternative *alpine area* egress design is proposed to that described in Part 3.7.5, that proposal must comply with *Performance Requirement* P2.3.5 in Section 2.

Acceptable construction practice

3.7.5.1 Application

Compliance with this Part for buildings which are located in *alpine areas* (see Figure 3.7.5.2) satisfies *Performance Requirement* P2.3.5.

3.7.5.2 External doorways

An external door in a building constructed in an *alpine area*, which may be subject to a build-up of snow must-

- (a) open inwards; and
- (b) be marked "OPEN INWARDS" on the inside face of the door in letters not less than 75 mm high and in a colour contrasting with that of the background; and
- (c) if it serves a corridor or stairway, be positioned in an alcove or recess with-
 - (A) no horizontal dimension of the alcove or recess less than twice the width of the door; and
 - (B) the door positioned to open against a wall such that the distance from any part of its swing to the nearest point of entry of the stairway or corridor is not less than the width of the door.

3.7.5.3 External ramps

An external ramp serving an external doorway must have a gradient not steeper than 1:12.

3.7.5.4 Discharge of external doorways providing a means of egress

A building in an *alpine area* must be constructed so that-

- (a) for any *external walls* more than 3.6 m above the natural ground level, the distance of that part of the building from the allotment boundary (other than a road alignment) must be not less than 2.5 m plus 100 mm for each 300 mm or part by which that part of the *external wall* exceeds a height of 3.6 m; and

- (b) an external doorway may discharge into a court between wings of a building provided the wings are not less than 6 m apart; and
- (c) where an external doorway discharges opposite a barrier or embankment which is more than 900 mm above the threshold of that doorway, the distance between the threshold and the barrier is not less than twice the height of the barrier or 6 m, whichever is the lesser (see Figure 3.7.5.3).

3.7.5.5 External trafficable structures

External stairways, ramps, access bridges or other trafficable structures serving the building must have-

- (a) a floor surface that consists of steel mesh or other suitable material if it is used as a means of egress; and
- (b) any required balustrade constructed so that its sides are not less than 75% open.

Figure 3.7.5.1

DESIGN FOR SAFE EGRESS IN ALPINE AREAS - MINIMUM DIMENSIONS OF ALCOVE OR RECESS AT EXTERNAL DOORWAY

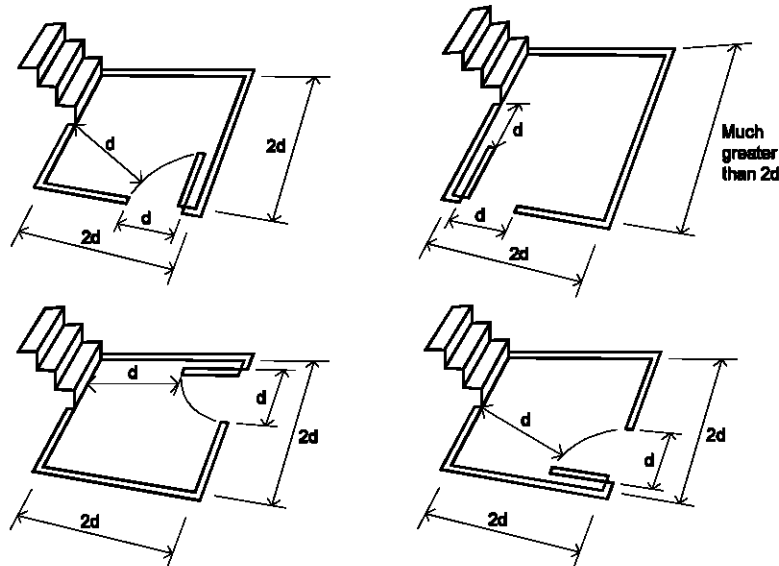

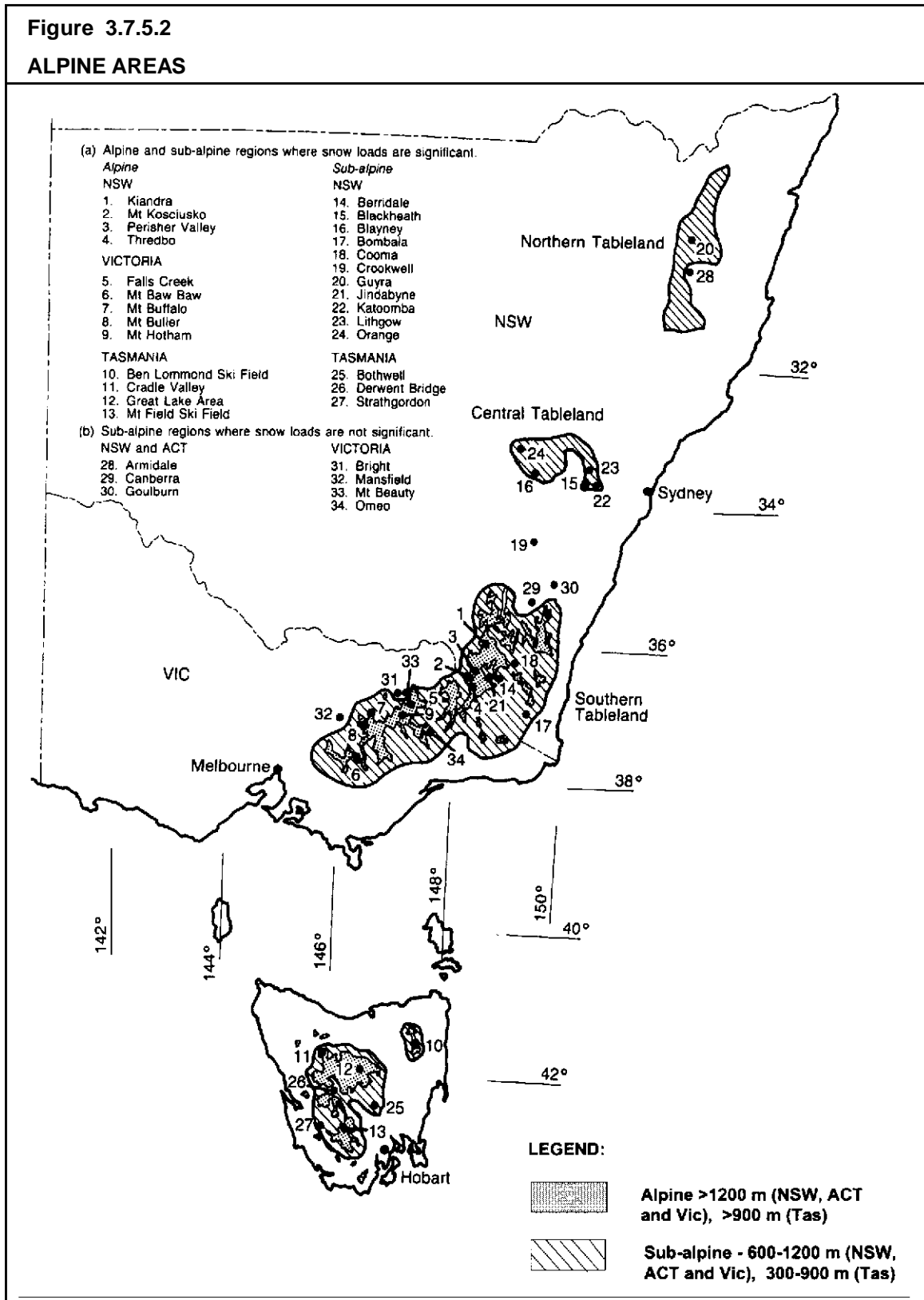

Explanatory information:

Alpine and sub-alpine areas are located in ACT, NSW, Victoria and Tasmania.

Alpine areas are areas 1200 m or more above Australian Height Datum (AHD) for NSW, ACT and Victoria, and 900 m or more above AHD for Tasmania, as shown in Figure 3.7.5.2.

Significant snowfalls (snowfalls which result in an average snow accumulation on the ground of 175 mm or greater) may occur in the sub-alpine areas shown in Figure 3.7.5.2. Part 3.7.5 does not apply to those areas because, unlike alpine areas, successive snowfalls are not likely to accumulate.

It is noted that in the ACT, the Canberra area is designated as a sub-alpine region where snow loads are not considered significant.

Amdt 3

Figure 3.7.5.3

DESIGN FOR SAFE EGRESS IN ALPINE AREAS - DISCHARGE OF EXTERNAL DOORWAY

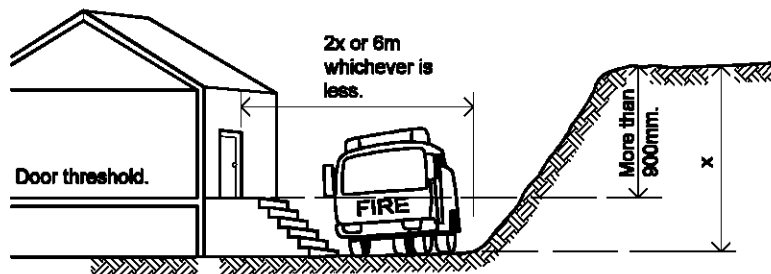

PART **3.8**

Amdt 3

HEALTH AND AMENITY

- 3.8.1 Wet Areas
- 3.8.2 Room Heights
- 3.8.3 Facilities
- 3.8.4 Light
- 3.8.5 Ventilation
- 3.8.6 Sound Insulation

PART 3.8 CONTENTS

	Page
3.8.1 Wet areas	19,021
3.8.1 Definitions	
3.8.1.0 Acceptable construction manual	
3.8.1.1 Application	
3.8.1.2 Wet areas	
3.8.1.3 Materials - general	
3.8.1.4 Protection of shower floors in wet areas	
3.8.1.5 Protection of walls in wet areas	
3.8.1.6 Sealing of wall and floor junctions and joints	
3.8.2 Room heights	19,301
3.8.2.1 Application	
3.8.2.2 Ceiling heights	
3.8.3 Facilities	19,501
3.8.3.1 Application	
3.8.3.2 Required facilities	
3.8.3.3 Construction of sanitary compartments	
3.8.4 Light	19,701
3.8.4.1 Application	
3.8.4.2 Natural lighting	
3.8.4.3 Artificial lighting	
3.8.5 Ventilation	19,901
3.8.5.0 Acceptable construction manual	
3.8.5.1 Application	
3.8.5.2 Ventilation requirements	
3.8.5.3 Location of sanitary compartments	
3.8.6 Sound insulation	20,101
3.8.6.1 Application	
3.8.6.2 Sound insulation requirements	
3.8.6.3 General installation requirements for walls	
3.8.6.4 Soil and waste pipes	

PART 3.8.1 WET AREAS

Appropriate *Performance Requirements*:

Where an alternative system for protecting *wet areas* in a building is proposed to that described in Part 3.8.1, that proposal must comply with *Performance Requirement P2.4.1*.

Definitions:

3.8.1 Definitions used in this Part are as follows:

Enclosed shower means a shower area enclosed for a height of 1.8 m above the shower floor area by water resistant walls, glazed panels or doors, metal framed shower screens, curtain or other similar materials that will control the spread of water.

Prefinished shower base means a *waterproof* preformed prefinished shower base which is installed as the finished floor of a shower compartment.

Shower tray means a *waterproof* liner which is installed in the shower compartment prior to the application of the floor and wall finishing system.

Waterproof means that a system or material will not allow the penetration of water.

Waterproof membrane means an applied *waterproof* barrier that is installed in the shower compartment.

Water resistant means a system or material that will restrict water migration.

Wet area means an area as defined in 3.8.1.2, within a building supplied with water from a water supply system and includes bathrooms, showers, laundries, *sanitary compartments* and the like.

Wet area fixture means a bath, laundry trough, basin, sink or similar fixture designed to contain water.

A. Acceptable construction manual

3.8.1.0 Performance Requirement P2.4.1 is satisfied for *wet areas* in Class 1 and 10 buildings if they are are waterproofed in accordance with AS 3740 - Waterproofing of wet areas within residential buildings

SA variation
Amdt No. 3

STATE AND TERRITORY VARIATIONS

3.8.1. does not apply in South Australia and 3.8.1.0 is replaced in South Australia with the following clause.

Performance Requirement P2.4.1 and SA 3.1 are satisfied for *wet areas* in Class 1 and 10 buildings if they are waterproofed in accordance with Minister's Specification SA F1.7 - Waterproofing of wet areas in buildings.

B. Acceptable construction practice
--

3.8.1.1 Application

Compliance with this Part satisfies *Performance Requirement P2.4.1* for *wet areas* provided the *wet area*-

- (a) is protected in accordance with the appropriate requirements of 3.8.1.3, 3.8.1.4, 3.8.1.5 and 3.8.1.6; and
- (b) complies with the appropriate details shown in Figures 3.8.1.5 to 3.8.1.11.

STATE AND TERRITORY VARIATIONS

3.8.1.1 does not apply in South Australia.

Note: Refer to SA 3.2.1.

3.8.1.2 Wet areas

The following areas of a building must be protected against water in accordance with 3.8.1.3 to 3.8.1.6 as appropriate:

- (a) Shower floor areas must comply with the following:
 - (i) Shower floors with a hob or set down:
 - (A) Within an *enclosed shower* (see Figure 3.8.1.1)-
 - (aa) to the outer face of the hob; or
 - (bb) where there is a set down of not less than 25 mm to the shower, 100 mm past the outside of the set down
 - (B) Where there is no *enclosed shower*, the area within 1.5 m radius measured horizontally from a point on the floor vertically below the shower rose (see Figure 3.8.1.1).
 - (ii) Floors adjacent to showers located above baths with no enclosure - the area within 1.5 m of the shower rose (see Figure 3.8.1.2).
 - (iii) Shower floors with no hob, 25 mm set down, or floor angle (see Figure 3.8.1.9) - the whole floor of the room.
- (b) Walls (including corner junctions)-
 - (i) within an *enclosed shower* (see Figure 3.8.1.1); or
 - (ii) where the shower is not an *enclosed shower*, within 1.5 m of the shower fitting, to a height of 1.8 m above the floor (see Figure 3.8.1.1); and
 - (iii) immediately adjacent or behind a *wet area fixture*-
 - (A) to a height not less than 150 mm above the fixture if the fixture is within 75 mm of the wall; and

3.8.1.2
(a)(iii)
Amdt No. 2

- (B) for the full width and/or breadth of the fixture (see Figure 3.8.1.3).
- (c) Floor, wall and bench junctions must comply with the following:
 - (i) The junction between the floor and wall-
 - (A) if the wall and floor are *required* to be protected; and
 - (B) in bathrooms containing showers.
 - (ii) The junction between the wall and any bench top or horizontal surface containing a *wet area fixture* if the wall is *required* to be protected.

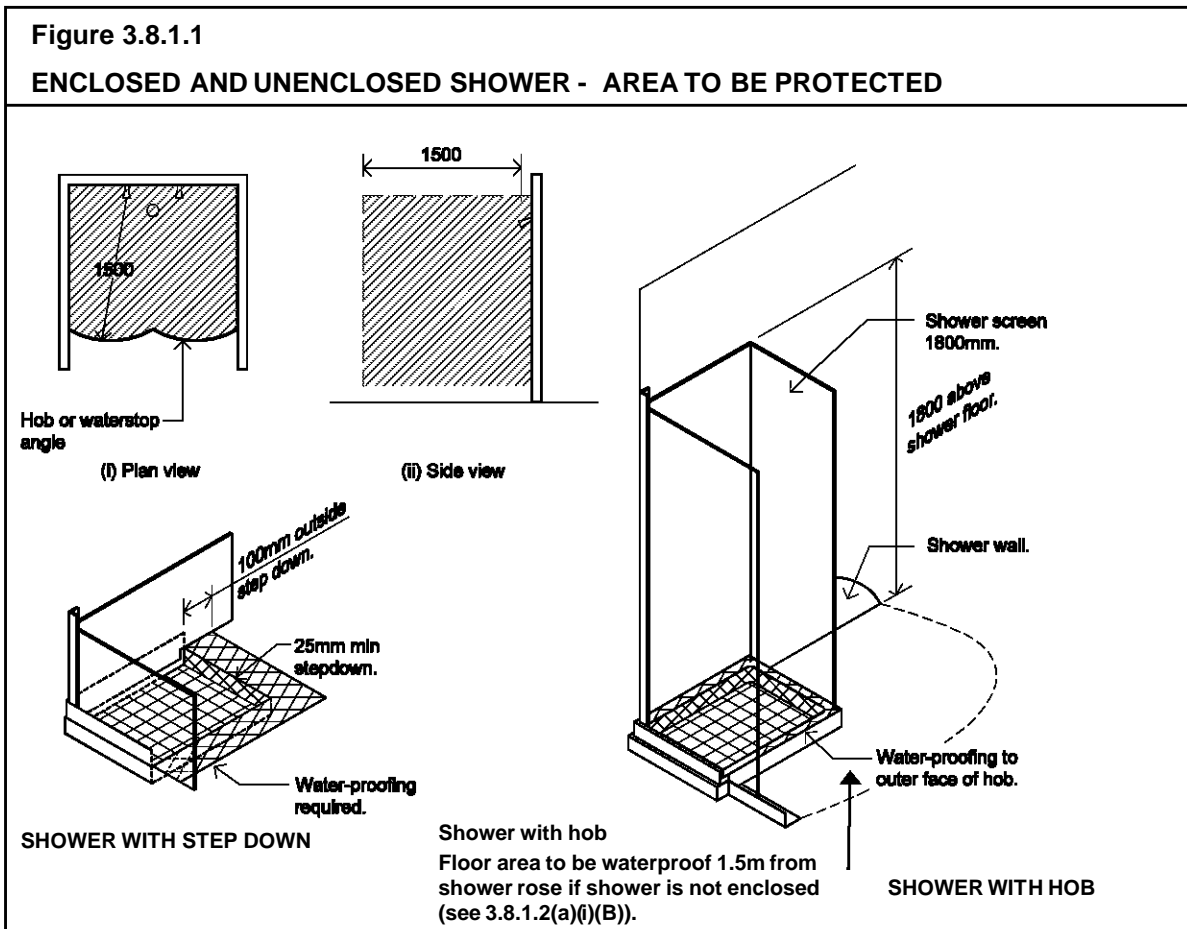

Amdt 3

Figure 3.8.1.2
SHOWERS ABOVE BATHS - AREA TO BE PROTECTED

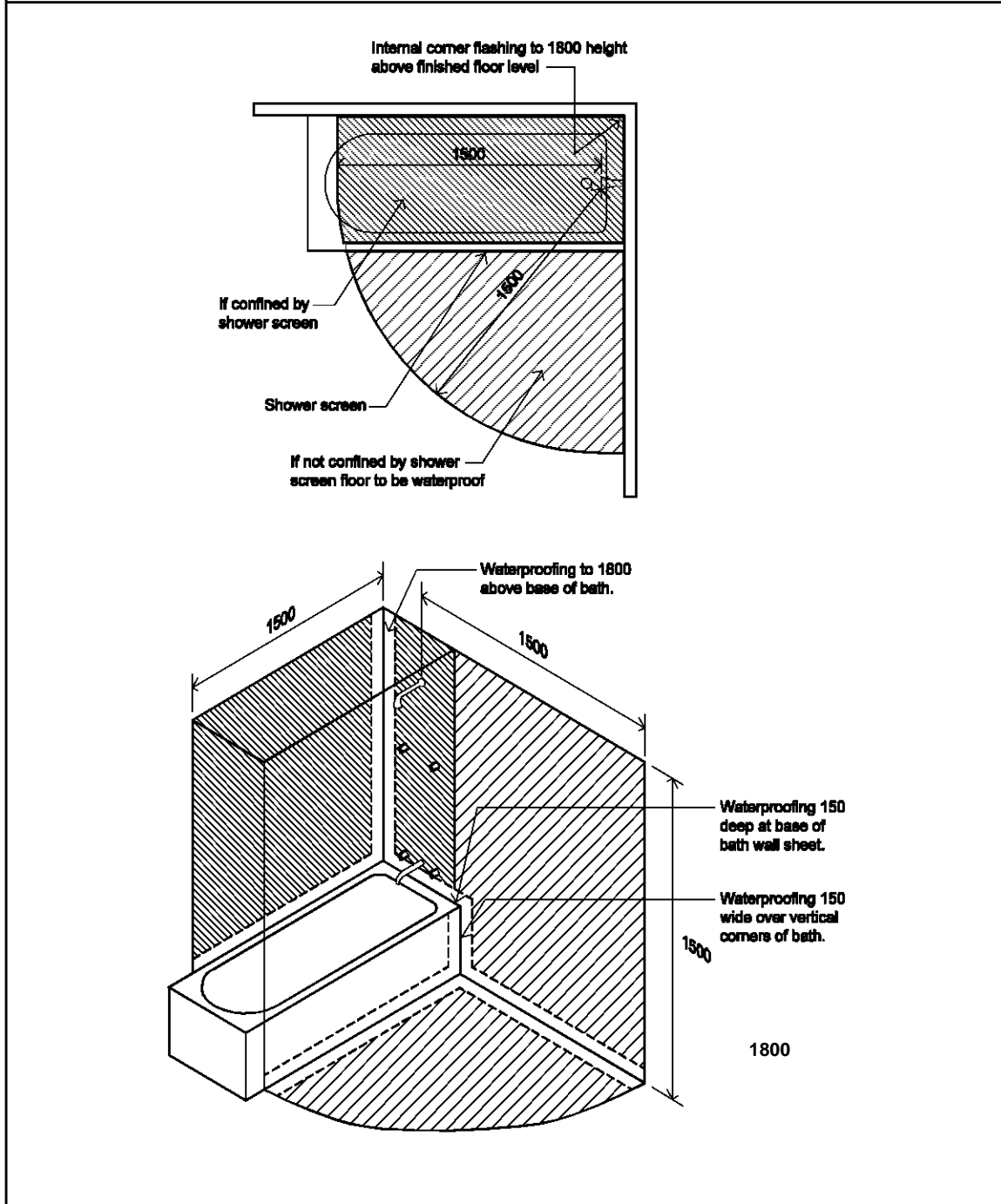

Amdt 3

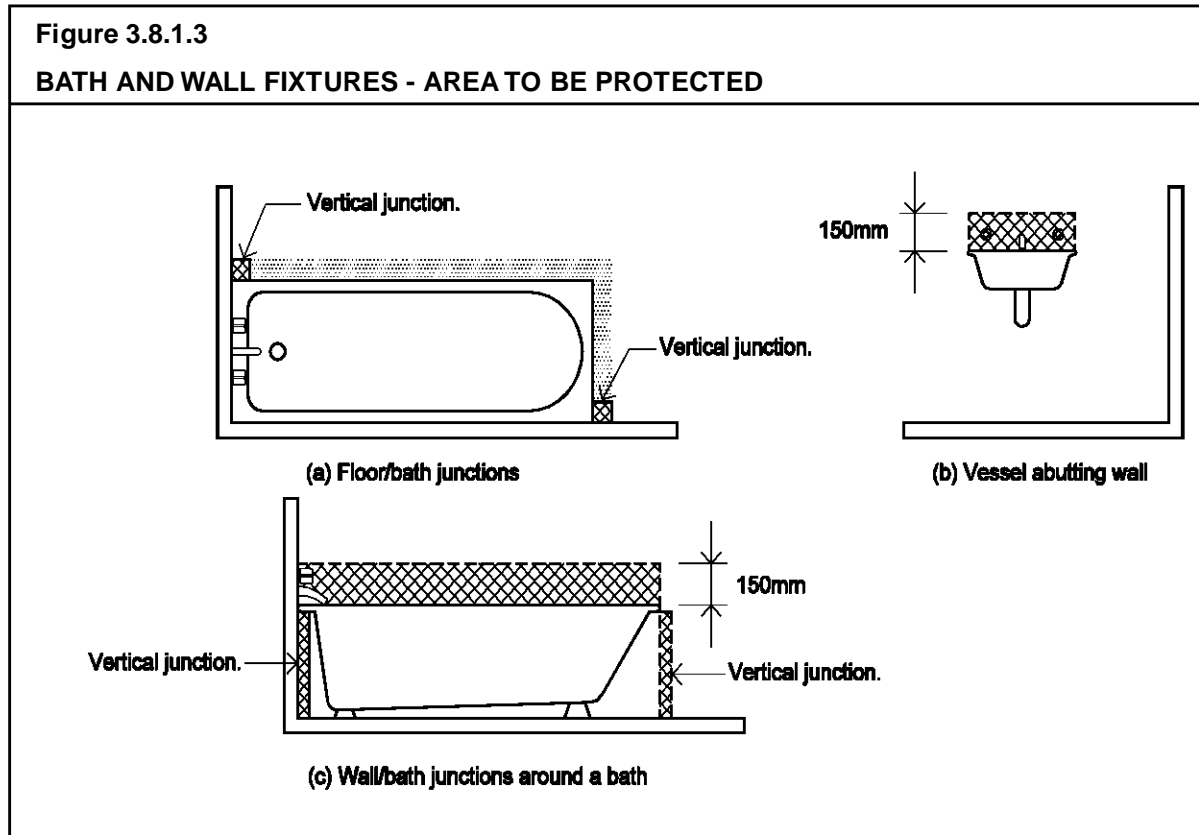

3.8.1.3 Materials - general

Materials used in *wet area waterproofing* and *water resistant* construction must be as follows:

- (a) Flashing angles must be *waterproof* and have dimensions not less than-
 - (i) for wall angles - 40x40 mm; and
 - (ii) for floor angles - 25 mm above finished adjoining floor level x 50 mm.
- (b) Grout used for ceramic tiles must comply with, and be installed in accordance with AS 3958.1.
- (c) Flexible sealants must be waterproof, neutral, self curing, flexible and mould resisting or polysulphide-based sealants complying with AS 1526 and AS 1527 and must be compatible with the adjoining materials.

3.8.1.4 Protection of shower floors in wet areas

The shower floor area as defined in 3.8.1.2(a) must-

- (a) be *waterproofed* in accordance with one of the following systems:
 - (i) A *shower tray* with sides which are the greater of-
 - (A) 100 mm above the finished floor surface; and
 - (B) 75 mm above the adjoining structural floor level; and
 - (C) 25 mm above the maximum possible water level of the shower compartment; or
 - (ii) a *waterproof membrane* extending 100 mm up the adjoining shower or bathroom area walls and turned down into a drainage flange; or
 - (iii) a *prefinished shower base*.
- (b) in shower areas (other than outside a bath), have a grade of not less than 1:60 to the shower trap or drainage flange; and
- (c) be finished with grouted glazed tiles-
 - (i) adhered to the floor substrate; or
 - (ii) bedded in mortar.

3.8.1.5 Protection of walls in wet areas

Wet area walls as defined in 3.8.1.2(b) must-

- (a) be *water resistant*, consisting of-
 - (i) smooth steel float finished concrete; or
 - (ii) cement render not less than 10 mm thick with a hard smooth finish; or
 - (iii) terrazzo; or
 - (iv) Pre-finished wall panels sealed with a flexible sealant at joints; or
- (b) consist of a *water resistant* lining suitably attached or adhered to a *water resistant* substrate with all joints sealed in accordance with 3.8.1.6; and
 - (i) for the purpose of this clause, suitable *water resistant* wall substrates are-
 - (A) *wet area* plasterboard sheet; or
 - (B) fibre cement sheet; or
 - (C) masonry; and

- (ii) suitable *water resistant* wall linings are-
 - (A) ceramic tiles; or
 - (B) slate; or
 - (C) stone tiles; or
 - (D) sheet vinyl with a thickness not less than 1 mm wear layer, fully bonded to the substrate, with joints welded or seam-sealed.

3.8.1.6 Sealing of wall and floor junctions and joints

Wall, floor and bench junctions as defined in 3.8.1.2(c) and wall joints in *wet areas* must be sealed as follows:

- (a) Vertical wall junctions in shower areas must be-
 - (i) flashed; and
 - (ii) where the flashing is above a *shower tray* or membrane, it must be lapped inside the *shower tray* or membrane not less than 25 mm (where possible); and
 - (iii) for *wet area* plasterboard, reinforced with tape set in *water resistant* taping compound and sealed with *water resistant* sealer.
- (b) Horizontal and vertical joints (other than wall junctions) in *wet area* plasterboard must be reinforced with tape set in *water resistant* taping compound and sealed with *water resistant* sealant.
- (c) The junction between the wall and shower or bath must be sealed with a flexible sealant in accordance with Figure 3.8.1.11.
- (d) The junction between the wall and *wet area fixtures* or benches containing a *wet area fixture* must be sealed with a flexible sealant in accordance with Figure 3.8.1.10.
- (e) Tap fittings in shower recesses must be sealed with flexible sealant or sealed with a *waterproof* flange in accordance Figure 3.8.1.6.
- (f) Finished wall and floor tile junctions must not be grouted, but sealed with a flexible sealant to create a flexible movement joint and the wall tiles must finish over the edge of the floor tiles (see Figure 3.8.1.8).

3.8.1.6
(a)(iii)
Amdt No. 2

3.8.1.6(b)
Amdt No. 2

Figure 3.8.1.5
TYPICAL VIEW OF SHOWER RECESS AND LINING MATERIALS

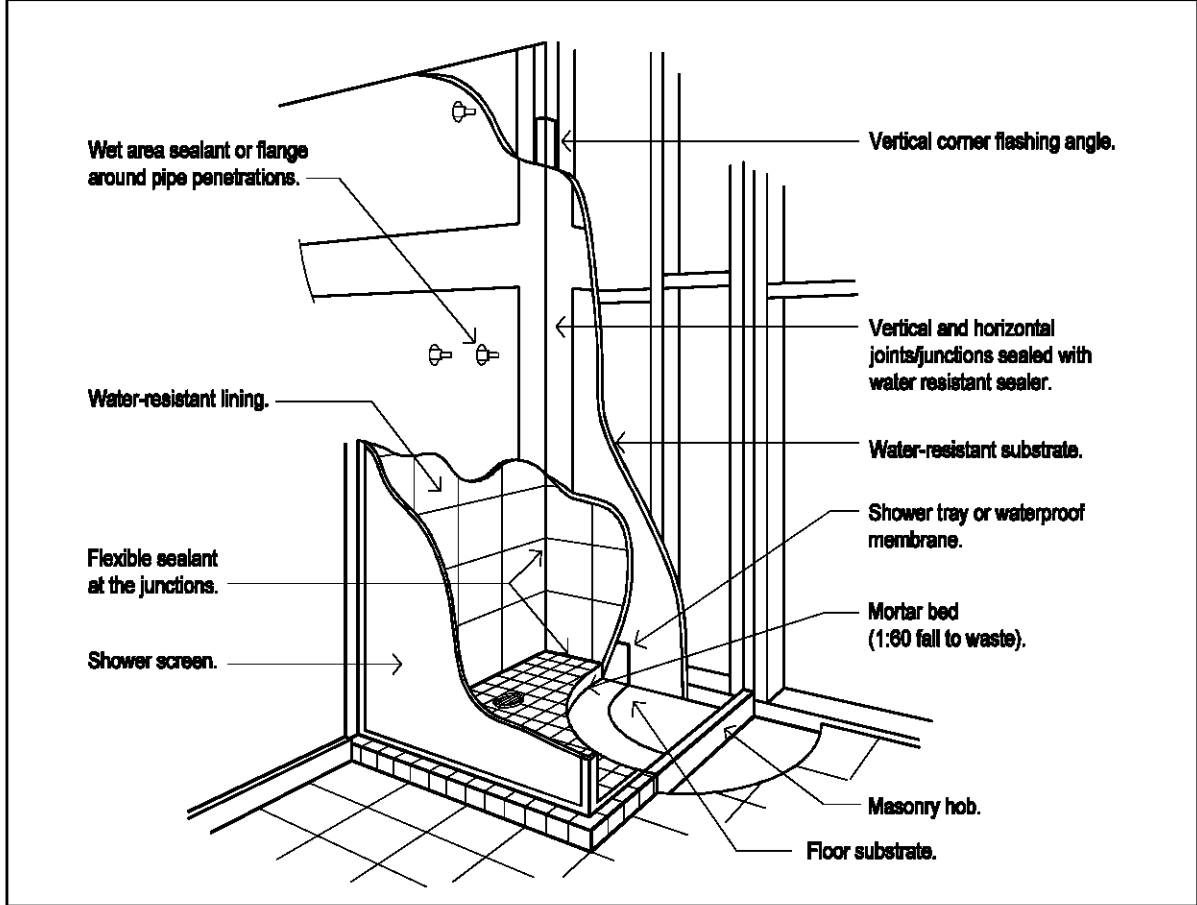

Figure 3.8.1.6
TYPICAL INSTALLATION OF TAP FLANGE

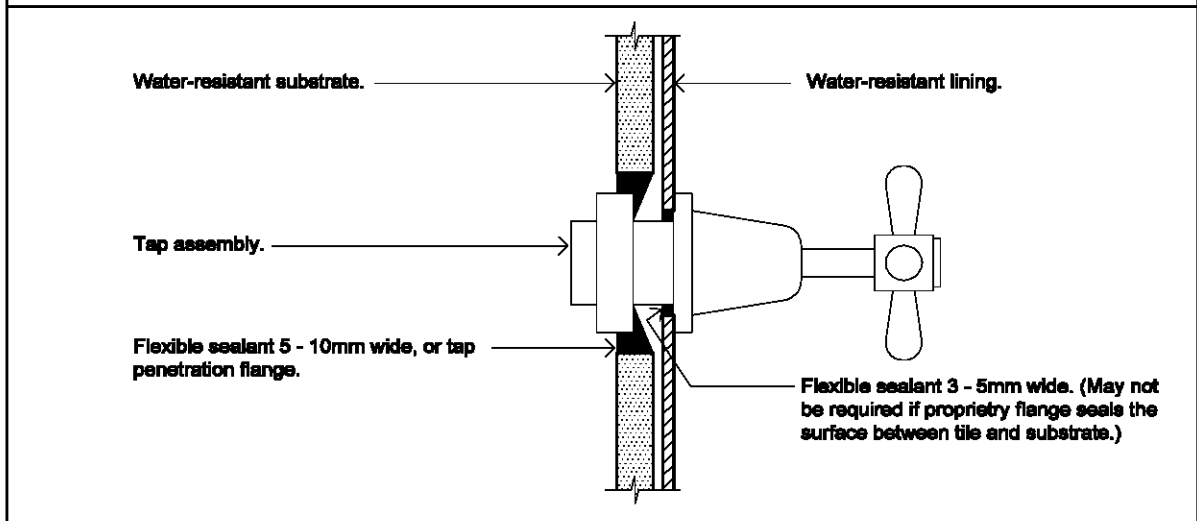
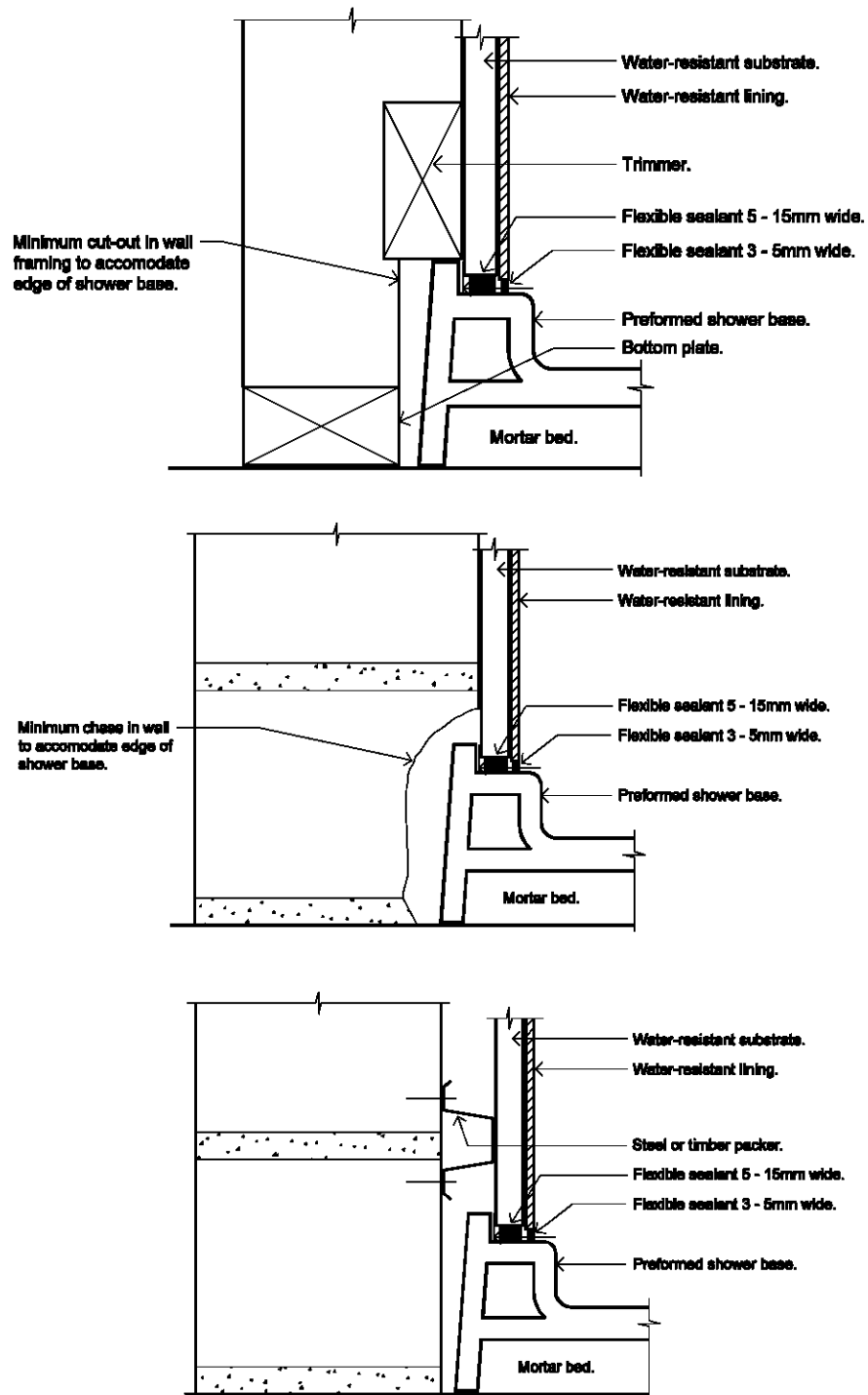
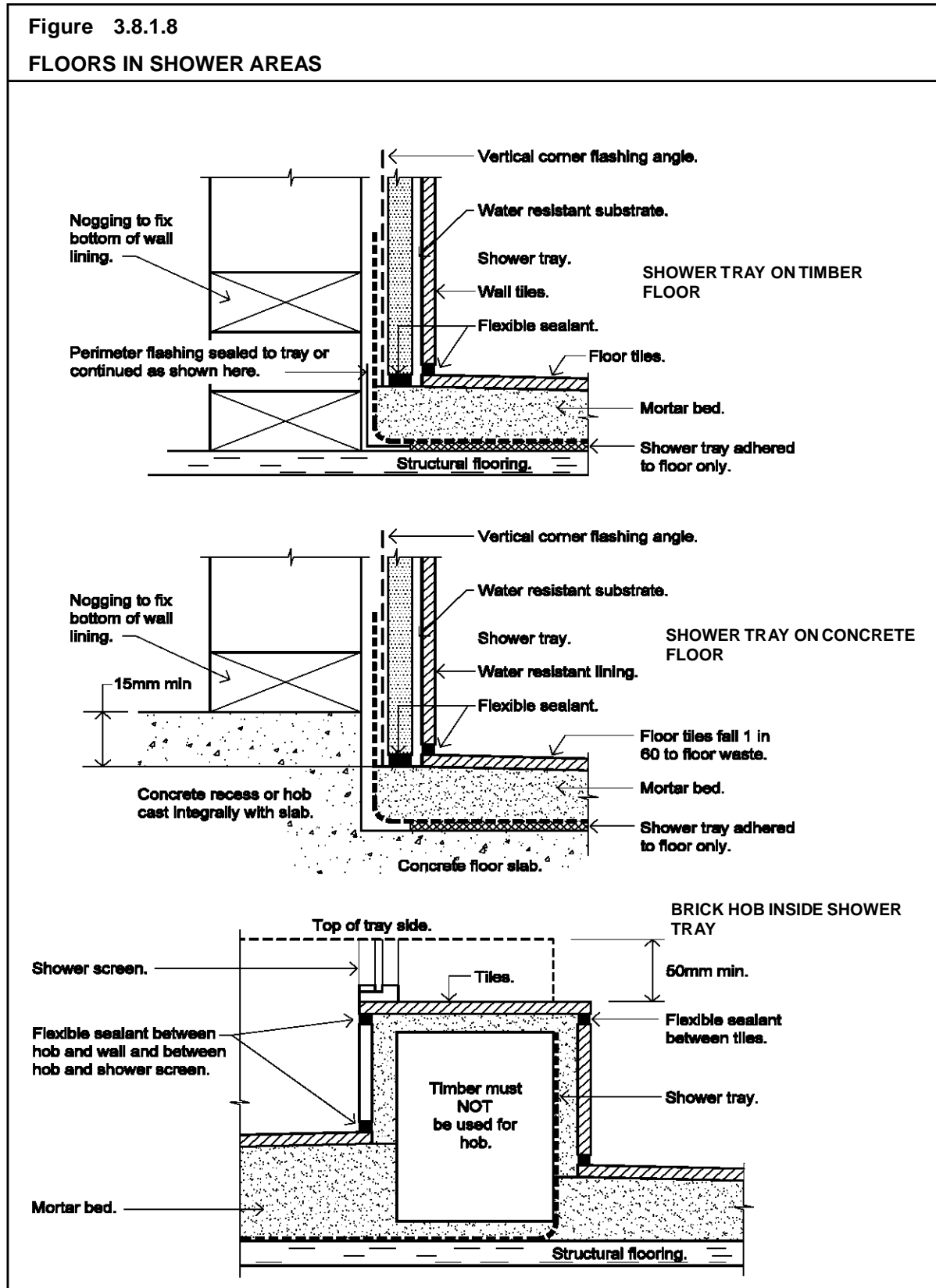

Figure 3.8.1.7
TYPICAL INSTALLATION OF PREFORMED SHOWER TRAYS IN TIMBER FRAMED AND MASONRY WALLS



Amdt 3

Figure 3.8.1.8
FLOORS IN SHOWER AREAS



Amdt 3

Figure 3.8.1.9

TYPICAL INSTALLATION OF WATERPROOF MEMBRANE TO SHOWER FLOOR

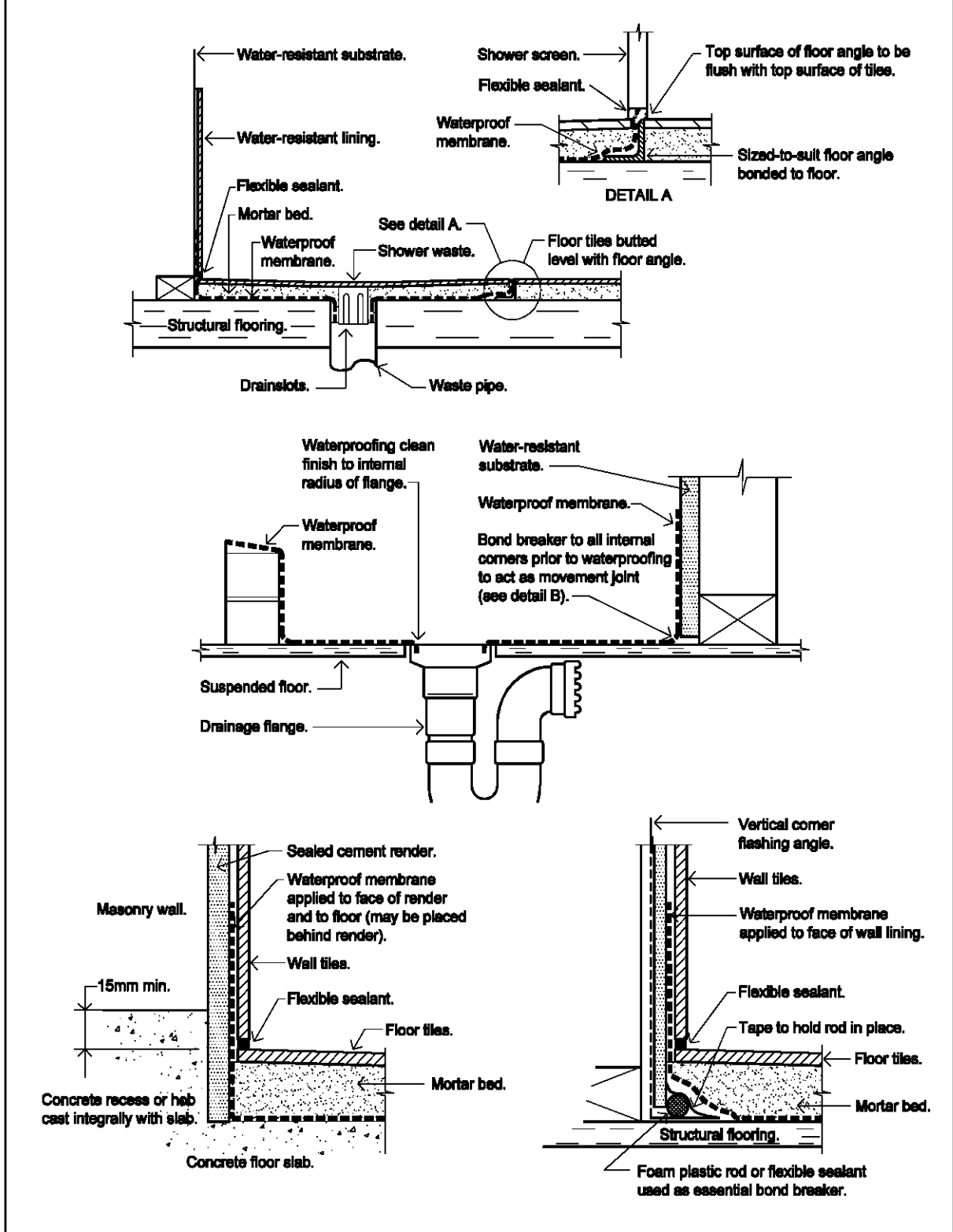

Amdt 3

Figure 3.8.1.10

TYPICAL WALL JUNCTIONS WITH FIXTURES

Diagram a.

WALL AND BENCH TOP JUNCTION

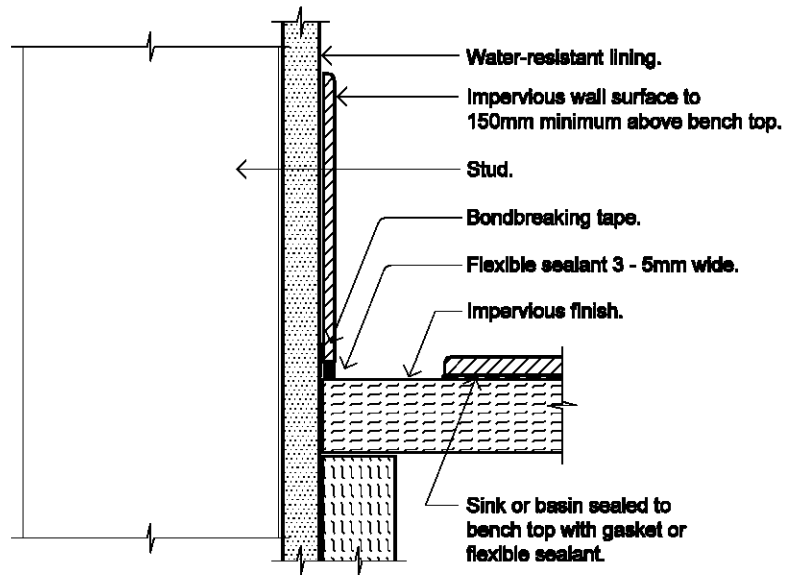
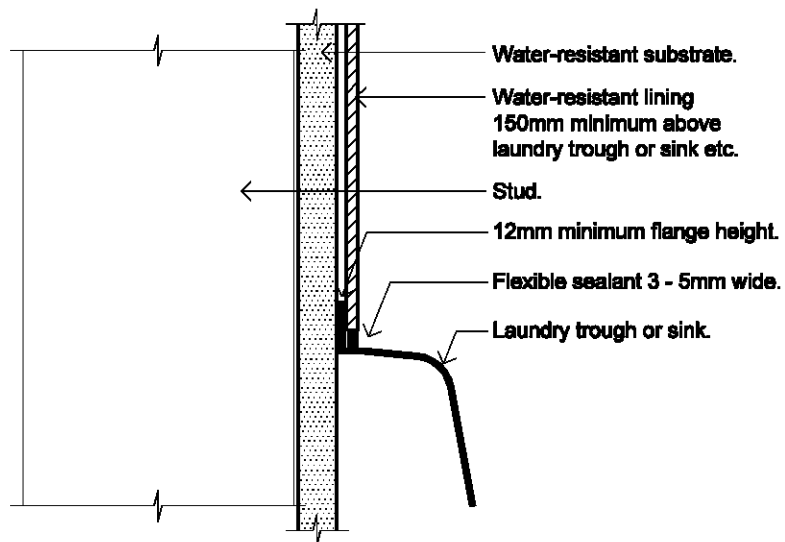

Diagram b.

WALL AND LAUNDRY SINK JUNCTION



Amdt 3

Figure 3.8.1.11
TYPICAL WALL AND BATH JUNCTIONS

Diagram a. MASONRY WALL JUNCTION

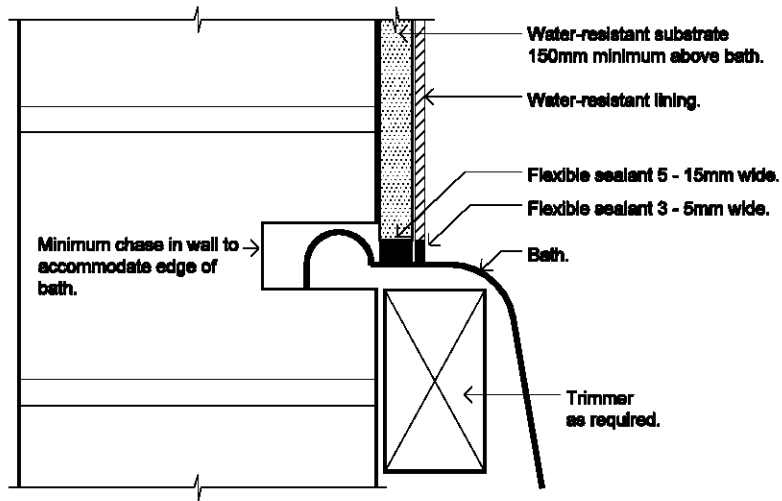
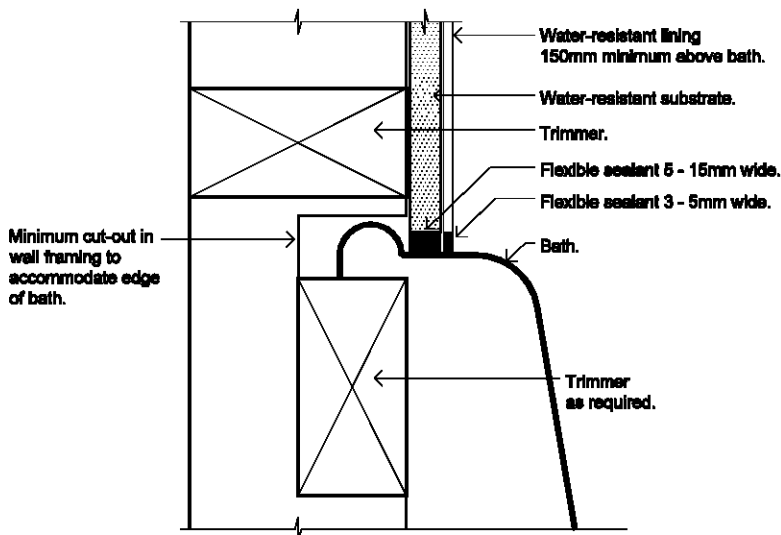

Diagram b. TIMBER WALL JUNCTION



Amdt 3

PART 3.8.2 ROOM HEIGHTS

Appropriate Performance Requirements:

Where an alternative ceiling height is proposed to that described in Part 3.8.2, that proposal must comply with *Performance Requirement P2.4.2* in Section 2.

Acceptable construction practice**3.8.2.1 Application**

Compliance with this Part satisfies *Performance Requirement P2.4.2* for room heights.

3.8.2.2 Ceiling heights

Ceiling heights (see Figure 3.8.2.1) must be not less than-

- (a) in a *habitable room* excluding a kitchen - 2.4 m; and
- (b) in a kitchen - 2.1 m; and
- (c) in a corridor, passageway or the like - 2.1 m; and
- (d) in a bathroom, shower room, laundry, *sanitary compartment*, airlock, pantry, storeroom, garage, car parking area or the like - 2.1 m; and
- (e) in an attic room, room with a sloping ceiling or projection below ceiling line or a non-*habitable* room or similar space - a height that does not unduly interfere with the proper functioning of the room or space.

(see Figure 3.8.2.1)

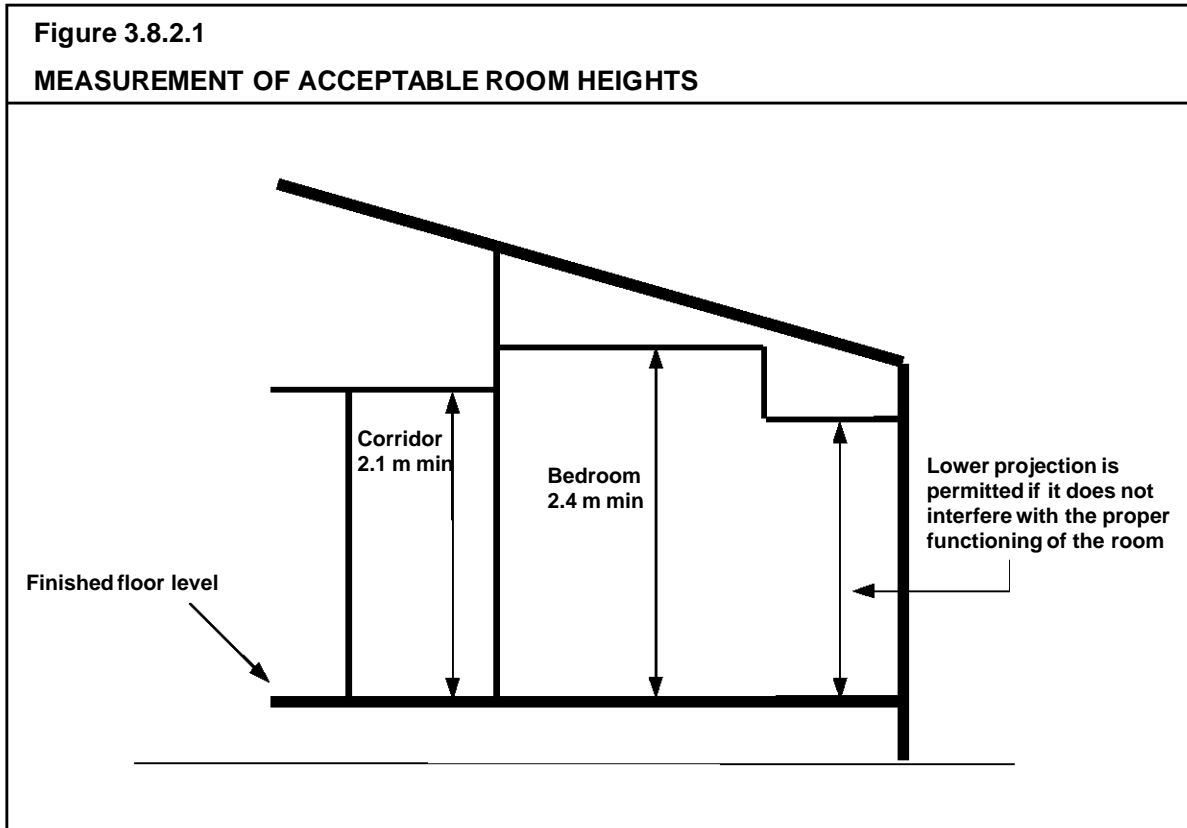

Amdt 3

PART 3.8.3 FACILITIES

Appropriate Performance Requirements:

Where an alternative arrangement for facilities is proposed to that described in Part 3.8.3, that proposal must comply with *Performance Requirement P2.4.3* in Section 2.

Acceptable construction practice

3.8.3.1 Application

Compliance with this Part satisfies *Performance Requirement P2.4.3* for facilities.

3.8.3.2 Required facilities

- (a) A Class 1 building must be provided with-
- (i) a kitchen sink and facilities for the preparation and cooking of food; and
 - (ii) a bath or shower; and
 - (iii) clothes washing facilities, comprising at least one washtub and space in the same room for a washing machine; and
 - (iv) a closet pan and washbasin.
- (b) If any of the facilities in (a) are detached from the main building, they must be set aside for the exclusive use of the occupants of the building.

3.8.3.3 Construction of sanitary compartments

3.8.3.3
Amdt No. 3

The door to a fully enclosed *sanitary compartment* must-

- (a) open outwards; or
- (b) slide; or
- (c) be readily removable from the outside of the compartment,

unless there is a clear space of at least 1.2 m between the closet pan within the *sanitary compartment* and the nearest part of the doorway.

Explanatory Information:

3.8.3.3 requires means of removing an unconscious occupant from a fully enclosed *sanitary compartment*. If the enclosure has gaps that are large enough to allow access for a person into the *sanitary compartment*, the compartment is not considered enclosed for the purpose of this clause.

STATE AND TERRITORY VARIATIONS

Part 3.8.3.4 is added as follows in Tasmania.

Installation of closet fixtures

- (a) If a sufficient sewerage system is not available, an authorised alternative means of disposal of sewage, may be installed.
- (b) If sanitary facilities are not water-flushed, the following provisions apply.
 - (i) A pit latrine, an incinerating toilet, a chemical toilet, a removable pan or a non-flushing urinal must not be within 2 m of a building containing habitable rooms.
 - (ii) The floor on which a removable pan is placed must be impervious.
 - (iii) A room containing a composting toilet must be separated from habitable rooms by way of a permanently ventilated air lock (which may be a circulation space).
 - (iv) The minimum ventilation *required* under (iii) shall be the greater of-
 - (A) 8000 mm²; or
 - (B) 1/500th of the *floor area* of the circulation space.
 - (v) Access for maintenance or removal of waste from a composting toilet must be by way of an access door which opens directly to the outside of the building.

PART 3.8.4 LIGHT

Appropriate Performance Requirements:

Where an alternative lighting system is proposed to that described in Part 3.8.4, that proposal must comply with *Performance Requirement P2.4.4* in Section 2.

Acceptable construction practice

3.8.4.1 Application

Compliance with this Part for a Class 1 building satisfies *Performance Requirement P2.4.4* for lighting.

3.8.4.2 Natural lighting

Natural lighting must be provided in a Class 1 building to all *habitable rooms*, in accordance with the following:

- (a) Natural lighting must be provided by *windows* that-
 - (i) have an aggregate light transmitting area measured exclusive of framing members, glazing bars or other obstructions of not less than 10 % of the *floor area* of the room; and
 - (ii) are open to the sky or face a court or other space open to the sky or an open verandah, carport or the like.
- (b) A *window required* to provide natural light that faces a boundary of an adjoining allotment must not be less than a horizontal distance of 900 mm from that boundary.
- (c) Natural lighting to a room in a Class 1 building may come through a glazed panel or opening from an adjoining room (including an enclosed verandah) if-
 - (i) the glazed panel or opening has an area of not less than 10 % of the *floor area* of the room to which it provides light; and
 - (ii) the adjoining room has *windows* with an aggregate light transmitting area of not less than 10 % of the combined *floor areas* of both rooms; and
 - (iii) the areas specified in (i) and (ii) may be reduced as appropriate if direct natural light is provided from another source.

(see Figure 3.8.4.1)

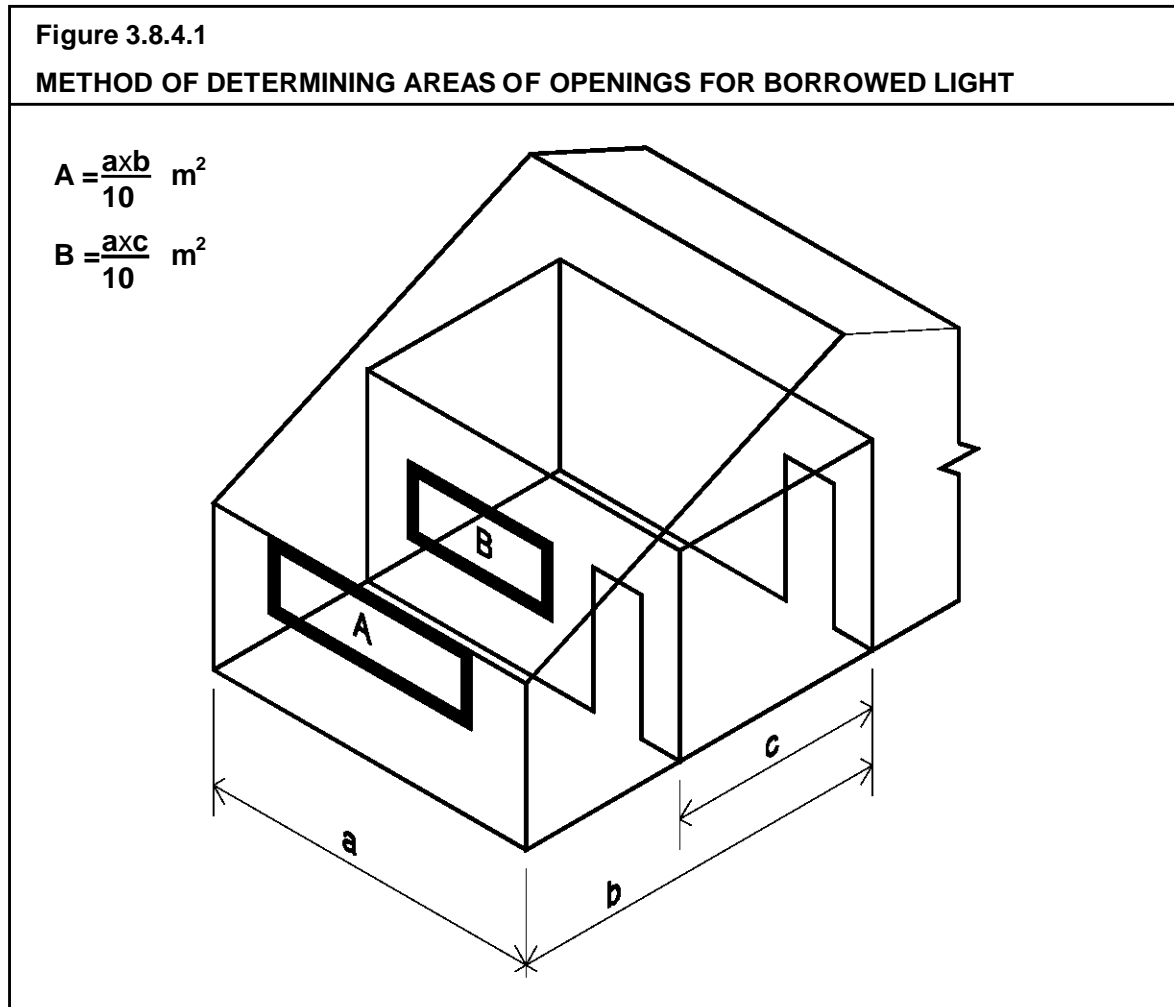
**3.8.4.3 Artificial lighting**

Sanitary compartments, bathrooms, shower rooms, airlocks and laundries must be provided with artificial light if natural lighting in accordance with the relevant provisions of 3.8.4.2 is not available-

- (a) at a rate of not less than one light fitting per 16 m² of *floor area*; or
- (b) in accordance with AS 1680.

PART 3.8.5 VENTILATION

Appropriate *Performance Requirements*:

Where an alternative ventilation system is proposed to that described in Part 3.8.5, that proposal must comply with *Performance Requirement* P2.4.5 in Section 2.

A. Acceptable construction manuals

3.8.5.0 *Performance Requirement* P2.4.5 is satisfied for a mechanical ventilation system if it is installed in accordance with AS 1668.2 - Mechanical ventilation for acceptable indoor air quality, except that any contaminated air from a *sanitary compartment* or bathroom must-

- (a) exhaust directly to outside the building by way of ducts; or
- (b) exhaust into the roof space provided-
 - (i) it is adequately ventilated by open eaves, and/or roof vents; or
 - (ii) the roof is clad in roofing tiles without sarking or similar materials which would prevent venting through gaps between tiles.

B. Acceptable construction practice

3.8.5.1 Application

Compliance with this Part satisfies *Performance Requirement* P2.4.5 for ventilation.

3.8.5.2 Ventilation requirements

Ventilation must be provided to a *habitable room*, *sanitary compartment*, bathroom, shower room, laundry and any other room occupied by a person for any purpose by any of the following means:

- (a) Permanent openings, *windows*, doors or other devices which can be opened-
 - (i) with an aggregate opening or openable size not less than 5% of the *floor area* of the room *required* to be ventilated; and
 - (ii) open to-
 - (A) a suitably sized court, or space open to the sky; or
 - (B) an open verandah, carport, or the like; or
 - (C) an adjoining room in accordance with (b).

- (b) Natural ventilation to a room may come through a *window*, opening, ventilating door or other device from an adjoining room (including an enclosed verandah) if-
- (i) the room to be ventilated or the adjoining room is not a *sanitary compartment*; and
 - (ii) the *window*, opening, door or other device has a ventilating area of not less than 5 % of the *floor area* of the room to be ventilated; and
 - (iii) the adjoining room has a *window*, opening, door or other device with a ventilating area of not less than 5 % of the combined *floor areas* of both rooms; and
 - (iv) the ventilating areas specified may be reduced as appropriate if direct natural ventilation is provided from another source.

(See Figure 3.8.5.1)

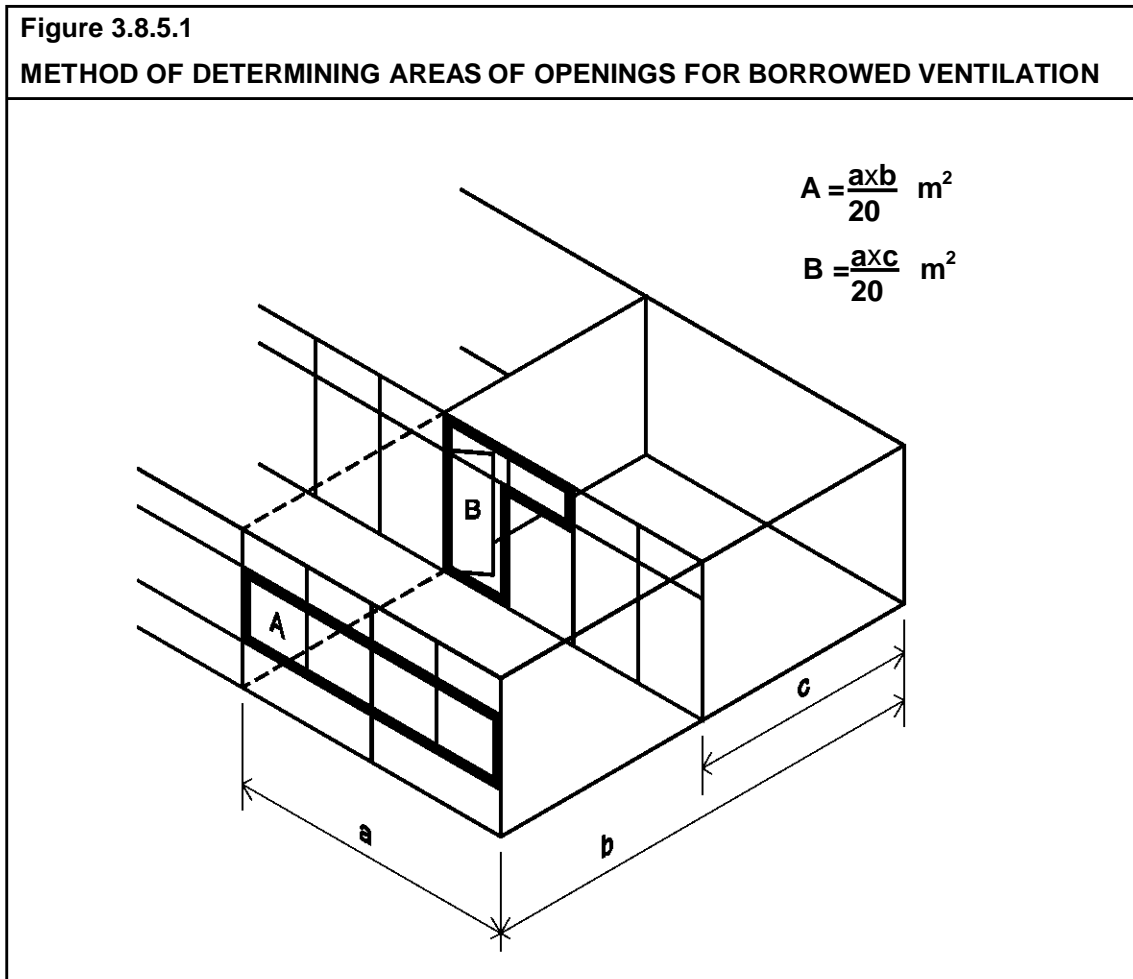

3.8.5.3 Location of sanitary compartments

Sanitary compartments must not open directly into a kitchen or pantry unless-

- (a) access is by an airlock, hallway or other room (see Figure 3.8.5.2); or
- (b) the room containing the closet pan is provided with mechanical exhaust ventilation installed in accordance with Part 3.8.5.

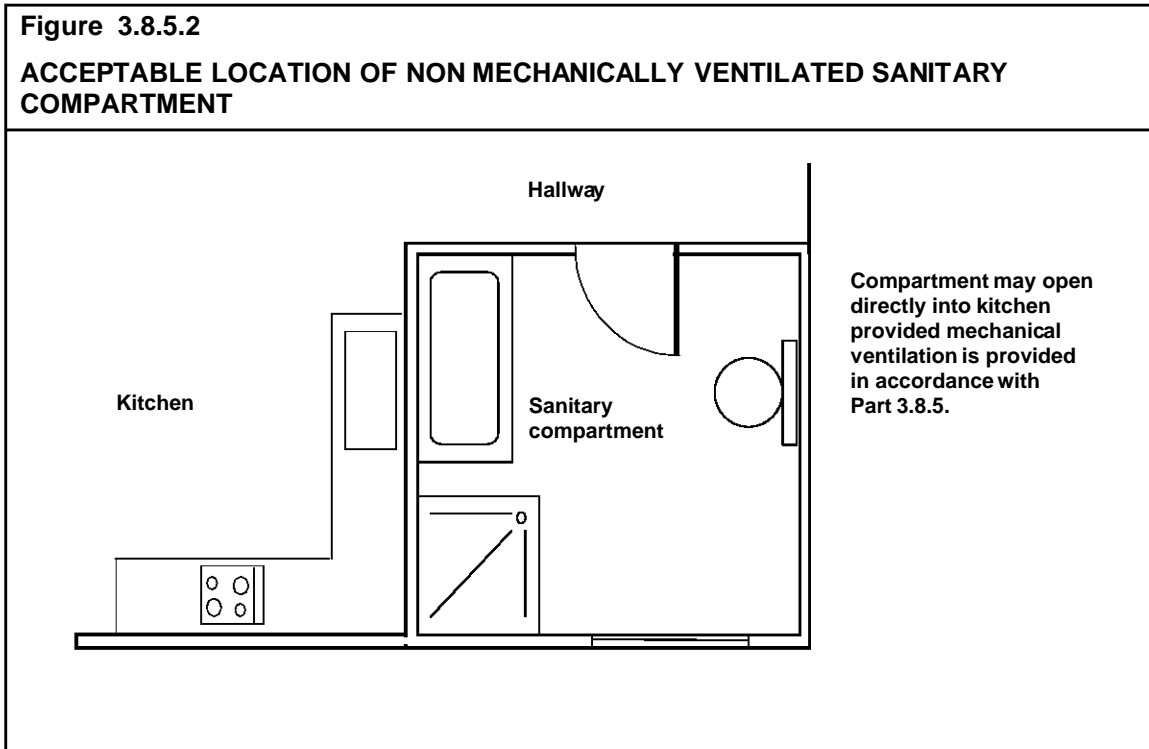

Amdt 3

PART 3.8.6 SOUND INSULATION

Appropriate Performance Requirements:

Where an alternative sound insulation system is proposed to that described in Part 3.8.6, that proposal must comply with *Performance Requirement P2.4.6* in Section 2.

Acceptable construction practice

3.8.6.1 Application

Compliance with this Part satisfies *Performance Requirement P2.4.6* for sound insulation.

3.8.6.2 Sound insulation requirements

- (a) A *separating wall* between two or more Class 1 buildings must-
 - (i) achieve the Sound Transmission Class (STC) and impact sound resistance *required* by Table 3.8.6.1; and
 - (ii) be installed in accordance with the appropriate requirements of 3.8.6.3 and 3.8.6.4; and
- (b) for the purpose of this Part, STC levels may be determined in accordance with AS 1276.

Table 3.8.6.1 REQUIRED STC AND SOUND IMPACT LEVELS FOR SEPARATING WALLS		
SEPARATING WALL - LOCATION AND PENETRATIONS	IMPACT SOUND RESISTANCE (As per Table 3.8.6.2)	STC LEVEL (As per Table 3.8.6.3)
TYPE A Between a bathroom, <i>sanitary compartment</i> , laundry or kitchen and a <i>habitable</i> room (other than a kitchen) in an adjoining Class 1 building (dwelling) (see Figure 3.8.6.1).	YES	50
TYPE B In all other cases than those listed as Type A. (See Figure 3.8.6.1)	NO	45
SOIL AND WASTE PIPES A waste pipe or other penetration that serves or passes through a <i>separating wall</i> between houses -	NO	45
(a) if the adjacent room is a <i>habitable room</i> (other than a kitchen); or	NO	30
(b) if the room is a kitchen or any other room.	NO	30

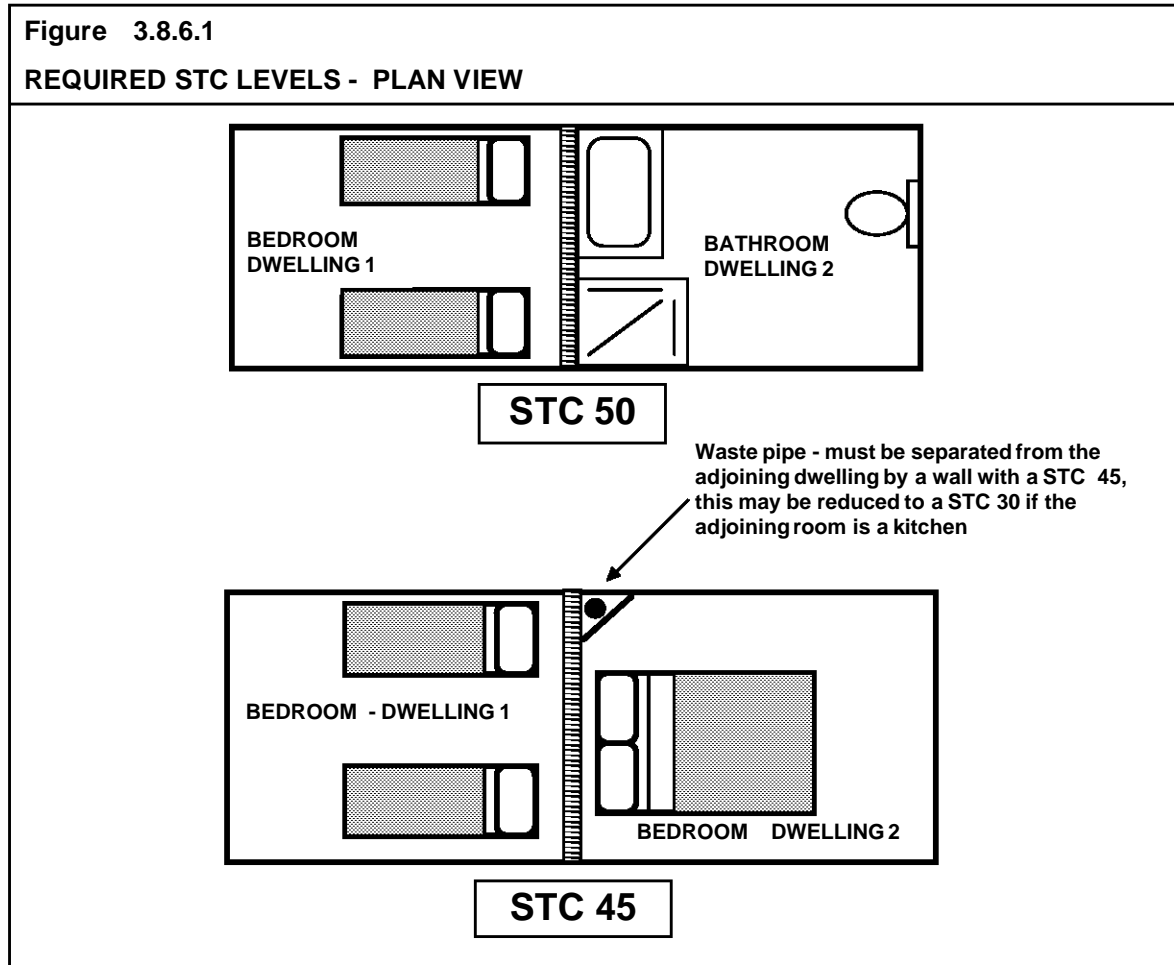

3.8.6.3 General installation requirements for walls

- (a) To achieve the appropriate STC and impact sound resistance, walls must-
- (i) be installed in accordance with the appropriate requirements contained in (b) to (f); and
 - (ii) at the junction of sound insulated walls with perimeter walls and roof cladding, be sealed in accordance with any relevant detail in Figure 3.8.6.3.
- (b) Masonry units must-
- (i) be laid with all joints filled solid, including those between the masonry and any adjoining construction; and
 - (ii) not be chased for services.
- (c) Joints between concrete slabs, wall units and any adjoining construction must be filled solid.

- (d) Plasterboard must be installed as follows:
- (i) If one layer is *required* under this Part, joints must be staggered with the joints in sheets on the opposite face of the wall.
 - (ii) If 2 layers are *required*, the first layer must be fixed according to (i) and the second layer must be fixed to the first layer with nails, screws or adhesive so that the joints do not coincide with those of the first layer.
 - (iii) Joints between sheets or between sheets and any adjoining construction must be taped and filled solid.
 - (iv) Fire-protective grade plasterboard (when nominated) must be the grade manufactured for use in *fire-resisting* construction.

Figure 3.8.6.2
TYPICAL INSTALLATION OF PLASTER SHEETS FOR SOUND INSULATION

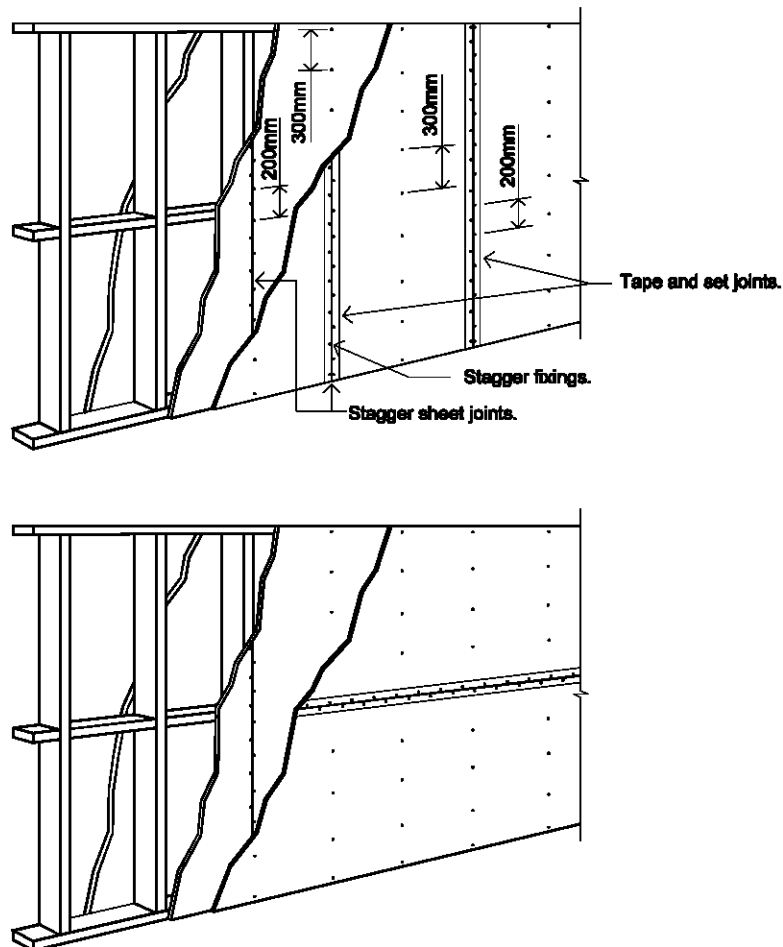

- (e) Steel studs and perimeter members must be installed as follows:
 - (i) The section of steel must be not less than 0.6 mm thick.
 - (ii) Studs must be not less than 63 mm in depth unless another depth is specified in the Table.
 - (iii) Studs must be fixed to steel top and bottom plates of sufficient depth to permit secure fixing of the plasterboard.
 - (iv) All steel members at the perimeter of the wall must be securely fixed to the adjoining structure and bedded in resilient compound or the joints must be caulked so that there are no voids between the steel members and the wall.
- (f) Timber studs and perimeter members must be installed as follows:
 - (i) Studs must be fixed to top and bottom plates of sufficient depth to permit secure fixing of the plasterboard.
 - (ii) Noggings and like members must not bridge between studs supporting different wall leaves.
 - (iii) All timber members at the perimeter of the wall must be securely fixed to the adjoining structure and bedded in resilient compound or the joints must be caulked so there are no voids between the timber members and the wall.

3.8.6.4 Soil and waste pipes

If a soil or waste pipe passes through *a separating wall*-



- (a) a door or panel providing access to the pipe must not open into any *habitable room*, other than a kitchen; and
- (b) an access door or panel in any other part must be firmly fixed so as to overlap the frame or rebate of the frame by not less than 10 mm, be fitted with a sealing gasket along all edges and constructed of-
 - (i) wood, plasterboard or blockboard not less than 38 mm thick; or
 - (ii) compressed fibre reinforced cement sheeting not less than 9 mm thick; or
 - (iii) other suitable material with a mass per unit area not less than 24.4 kg/m².

Explanatory Information:

The wall configurations shown in Tables 3.8.6.2 and 3.8.6.3 are typical examples. Other proprietary methods are available for meeting the STC and sound impact levels required by Table 3.8.6.1.

Table
3.8.6.2
Amdt No. 2

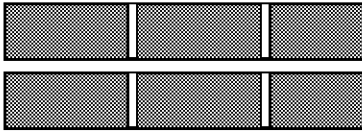
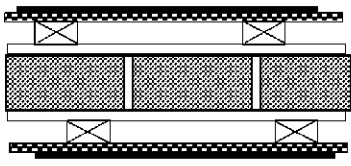
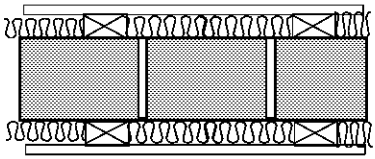
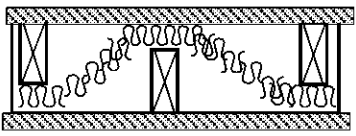
Table 3.8.6.2
CONSTRUCTION OF WALLS TO: (A) REDUCE IMPACT SOUND; AND
(B) ACHIEVE A 50 STC RATING

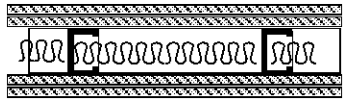
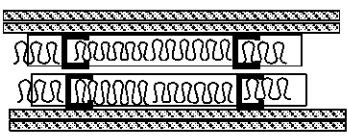

WALL CONSTRUCTION TYPE	DESIGN DIAGRAM - PLAN VIEW
<p>CAVITY BRICKWORK 2 leaves 90 mm brick masonry with-</p> <ul style="list-style-type: none"> (a) all joints filled solid with mortar; and (b) an air space not less than 40 mm between the leaves; and (c) the leaves connected only by ties in accordance with AS 3700 and wall tie spacing details as set out in Part 3.3. 	
<p>SINGLE LEAF BRICKWORK 80 mm thick brick masonry with-</p> <ul style="list-style-type: none"> (a) each face rendered 13 mm thick; and (b) 50x12 mm thick timber battens at not more than 610 mm centres fixed to each face but not recessed into the render; and (c) one layer of 12 mm thick softboard nailed to the battens; and (d) 6 mm thick medium density hardboard adhesive-fixed to the softboard. 	
<p>CONCRETE BLOCKWORK 190 mm thick concrete block masonry with-</p> <ul style="list-style-type: none"> (a) each face of the blocks fitted with 50x50 mm timber battens, spaced at not more than 610 mm centres, screw-fixed into resilient plugs with rubber inserts; and (b) the space between the battens completely filled with mineral or glass wool blanket or batts not less than 50 mm thick; and (c) the outer face of the battens finished with plasterboard not less than 10 mm thick. 	
<p>TIMBER FRAMED WALLING 70x45 mm F5 staggered timber studs at 300 mm centres on 120x35 mm F5 timber plates with-</p> <ul style="list-style-type: none"> (a) one layer of 16 mm fire protective grade plasterboard on both faces; and (b) 50 mm glass fibre batts. 	
<p>TIMBER FRAMED WALLING 70 x 45 mm F5 timber double studs at 450 - 600 mm centres with two layers of 13 mm fire protective grade plasterboard on both faces.</p>	
<p>STEEL STUD WALLING 64 mm metal studs (0.75 mm base metal thickness) clipped in 92 mm metal tracks at 600 mm centres with-</p> <ul style="list-style-type: none"> (a) two layers of 13 mm fire protective grade plasterboard to each side; and (b) 50 mm glasswool cavity batts. 	
<p>STEEL STUD WALLING 64 mm metal studs (0.75 mm base metal thickness) at 600 mm centres in separate frames with no mechanical links with-</p> <ul style="list-style-type: none"> (a) two layers of 13 mm fire protective grade plasterboard to each side; and (b) 50 mm glasswool cavity batts. 	

Amdt 3

**Table
3.8.6.3
Amdt No. 2**

Table 3.8.6.3 STC RATINGS APPLICABLE TO CONSTRUCTION		
WALL CONSTRUCTION TYPE	STC	DESIGN DIAGRAM - PLAN VIEW
CLAY BRICKWORK		
(a) 110 mm thick in one or more leaves and with a mass per unit area of not less than 290 kg/m ²	45	
(b) 80 mm thick, pressed brick and rendered 13 mm on one side, the mass per unit area of the unrendered wall being not less than 215 kg/m ² .	45	
CALCIUM SILICATE BRICKWORK		
(a) 90 mm thick calcium silicate brick with one layer of 10 mm fire protective grade plasterboard on each side.	45	
(b) 90 mm thick calcium silicate brick with one layer of 10 mm fire protective plasterboard and one layer of fire protective plasterboard on metal furring channels.	45	
CONCRETE BLOCKWORK		
(a) 190 mm solid units (or thicker) Material density 2200 kg/m ³ .	45	
(b) 110 mm solid units (or thicker) Material density 2200 kg/m ³ Material thickness - 83 mm min. 10 mm plasterboard or 12 mm render on each face.	45	
CONCRETE WALL		
In-situ concrete- 125 mm thick and with a density of not less than 2200 kg/m ³ .	45	

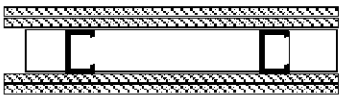
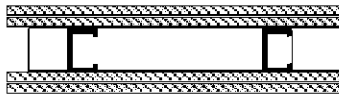
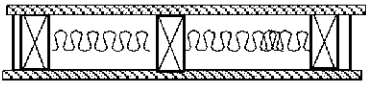
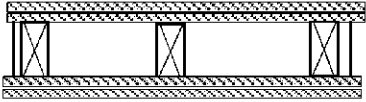
Amdt 3

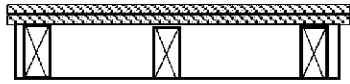
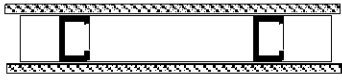
Table 3.8.6.3 (Continued)		
STC RATINGS APPLICABLE TO CONSTRUCTION		
WALL CONSTRUCTION TYPE	STC	DESIGN DIAGRAM - PLAN VIEW
STEEL STUD WALLING		
(a) With 2 layers of 16 mm thick fire-protective grade plasterboard fixed to each face.	45	
(b) With 2 layers of 13 mm plasterboard on both sides of 75 mm studs.	45	
TIMBER STUD WALLING		
70 x 45 mm timber studs at 450 - 600 mm centres with (a) one layer of 16 mm fire protective grade plasterboard on one face; and (b) 50 mm glass fibre batts, and (c) one layer of 16 mm fire protective grade plasterboard on metal resilient channel.	49	
70 x 45 mm timber studs at 450 - 600 mm centres with two layers of 16 mm fire protective grade plasterboard on both sides.	46	
DUCTS OR OTHER CONSTRUCTION SEPARATING SOIL AND WASTE PIPES FROM UNITS		
MASONRY-		
Not less than 90 mm thick.	30	
PLASTERBOARD-		
(a) 2 layers of plasterboard each 10 mm thick, fixed to timber studs not less than 75 mm x 50 mm and spaced at not more than 400 mm centres.	30	
(b) 2 layers of plasterboard each 13 mm thick, one on each side of steel studs not less than 50 mm deep and spaced at not more than 400 mm centres.	30	

Amdt 3

Figure 3.8.6.3

SOUND INSULATION BETWEEN UNITS - DOUBLE STUD WALL CONFIGURATION

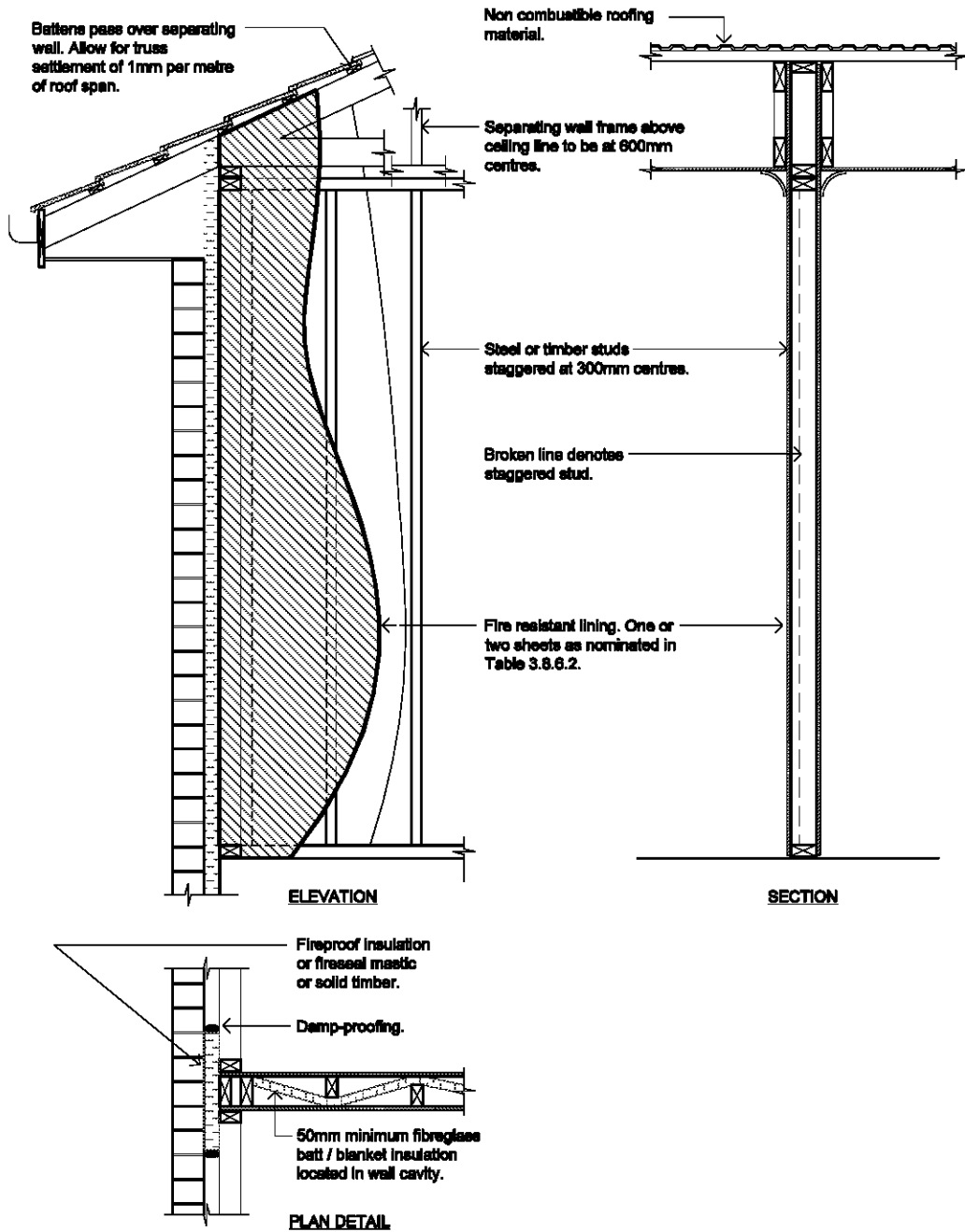

Amdt 3

PART **3.9**

Amdt 3

SAFE MOVEMENT AND ACCESS

3.9.1 Stair Construction

3.9.2 Balustrades

3.9.3 Swimming Pool Access

PART 3.9 CONTENTS

	Page
3.9.1 Stair construction	21,021
3.9.1 Definitions	
3.9.1.1 Application	
3.9.1.2 General requirements	
3.9.1.3 Stair construction	
3.9.1.4 Riser and going dimensions	
3.9.1.5 Thresholds	
3.9.2 Balustrades	21,201
3.9.2.0 Definitions	
3.9.2.1 Application	
3.9.2.2 When balustrades are required	
3.9.2.3 Balustrade construction	
3.9.3 Swimming pool access	21,401
3.9.3.0 Acceptable construction manual	
3.9.3.1 Application	
3.9.3.2 Safety fencing location and construction	

PART 3.9.1 STAIR CONSTRUCTION

Appropriate Performance Requirements:

Where an alternative stair system is proposed to that described in Part 3.9.1, that proposal must comply with *Performance Requirement P2.5.1* in Section 2.

Definitions

3.9.1 The following definitions are used in this Part:

Flight means that part of a stair that has a continuous series of treads, (including *winders* located within a straight stair) between *landings* (see Figure 3.9.1.1).

Explanatory Information:

A stair *flight* is the area of a stair that has a continuous slope created by the nosing line of treads. The length of a stair flight is limited to restrict the distance a person could fall down a stair. Quarter *landings* with no *winders*, as shown in Figure 3.9.1.1 are considered sufficient to halt a persons fall and therefore are considered for the purposes of this document not to be part of the stair *flight*.

Figure 3.9.1.1

IDENTIFICATION OF STAIR FLIGHTS - Plan view

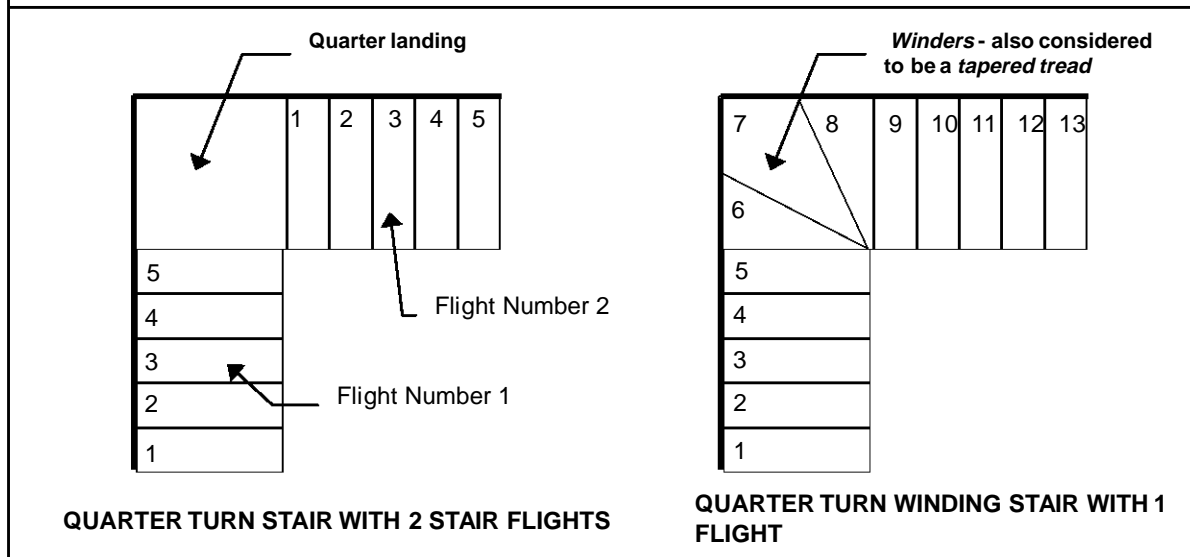

Going means the horizontal dimension from the front to the back of a tread less any overhang from the next tread above (see Figure 3.9.1.2).

Landing means a horizontal area at the top of, or between two *flights* of a stair.

Riser means the height between consecutive treads.

Spiral stair means a stair with a circular plan, winding around a central post with steps that radiate from a common centre or several radii (see Figure 3.9.1.4).

Tapered tread means a stair tread, such as a *winder*, with a walking area that grows smaller towards one end.

Winders means treads within a straight stair *flight* that are used to change direction of the stair (see Figure 3.9.1.1).

Acceptable construction practice

3.9.1.1 Application

Compliance with this Part satisfies *Performance Requirement P2.5.1*, provided the stair complies with the appropriate structural requirements of the *Housing Provisions*.

3.9.1.2 General requirements

- (a) Stairs serving *habitable rooms*, including external stairs must comply with 3.9.1.3 and 3.9.1.4.
- (b) Stairs serving non-habitable rooms, such as attics, storerooms and the like that are not used on a regular or daily basis, must be constructed in accordance with-
 - (i) the provisions of this Part; or
 - (ii) AS 1657 - Fixed platforms, walkways, stairways and ladders.

3.9.1.3 Stair construction

Stairs must be constructed in accordance with the following:

- (a) Each *flight* must have not more than 18 *risers*.
- (b) The nominal dimension of *goings* and *risers* of a stair must be constant throughout each stair *flight* except that the *going* of *winders* in a stepped quarter landing may vary from the *going* of the non-tapered treads within the same *flight* provided that the *going* of all tapered treads in the quarter landing is constant.
- (c) Treads must be of solid construction (not mesh or other perforated material) if the stairway is more than 10 m high or connects more than 3 storeys.
- (d) Stepped quarter landing areas, where installed, must not have more than 3 *winders*.
- (e) The *riser* opening must not allow a 125 mm sphere to pass through between the treads.
- (f) *Spiral stairs* must not be more than 1 m wide (see Figure 3.9.1.4).

- (g) Treads must have a non-slip finish or a suitable non-skid strip near the edge of the nosings.

3.9.1.4 Riser and going dimensions

The *riser* and *going* dimensions for each stair *flight* must comply with the following:

- (a) The *going* (G), *riser* (R) and slope relationship quantity (2R+G) must be in accordance with Figure 3.9.1.2.
- (b) The point for measurement of the *going* (G) in the slope relationship quantity as described in Figure 3.9.1.3 must be-
 - (i) for *tapered treads* (other than treads in a *spiral stair*)-
 - (A) not more than 1 m wide, the middle of the unobstructed width of the stair; and
 - (B) more than 1 m in width, 400 mm from the unobstructed width of each side of the stair (see Figure 3.9.1.3, Diagram(c)); and
 - (ii) for treads in *spiral stairs*, the point seven tenths of the unobstructed distance from the face of the centre pole or support towards the handrail side (see Figure 3.9.1.4).

Amdt 3

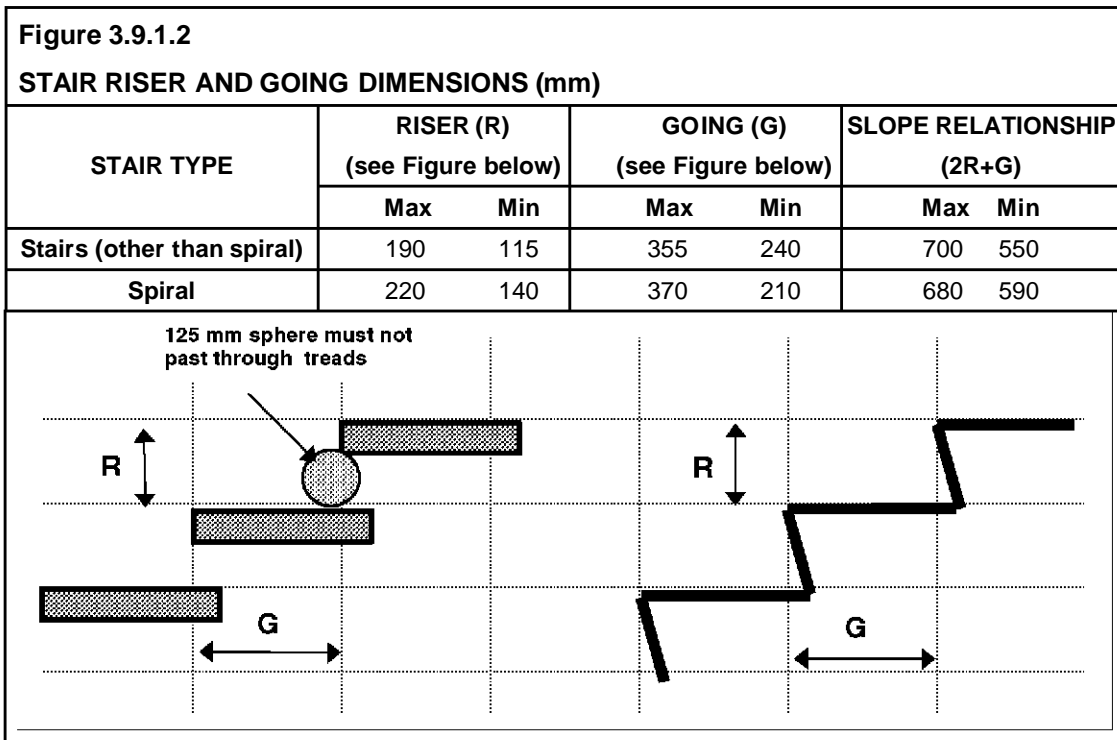

Figure 3.9.1.3

MEASUREMENT OF SLOPE RELATIONSHIP - Plan view

Diagram a. Stair with 2 flights

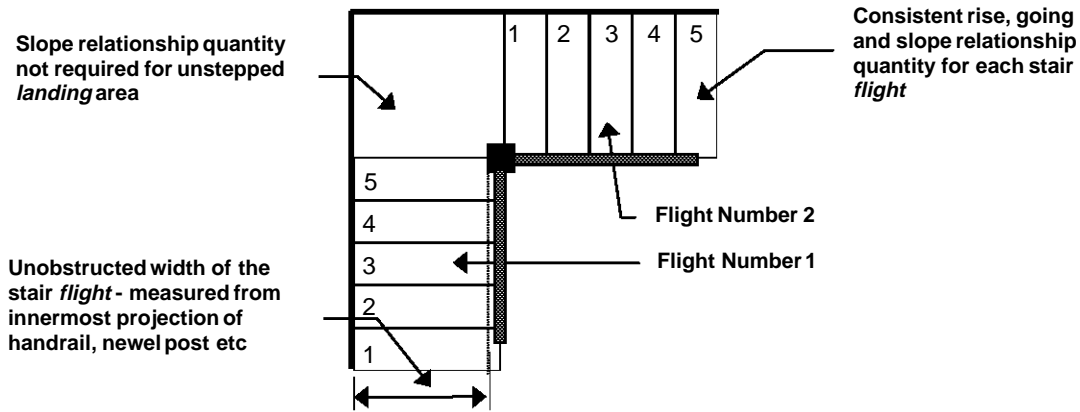

Diagram b. Tapered treads - less than 1 m wide

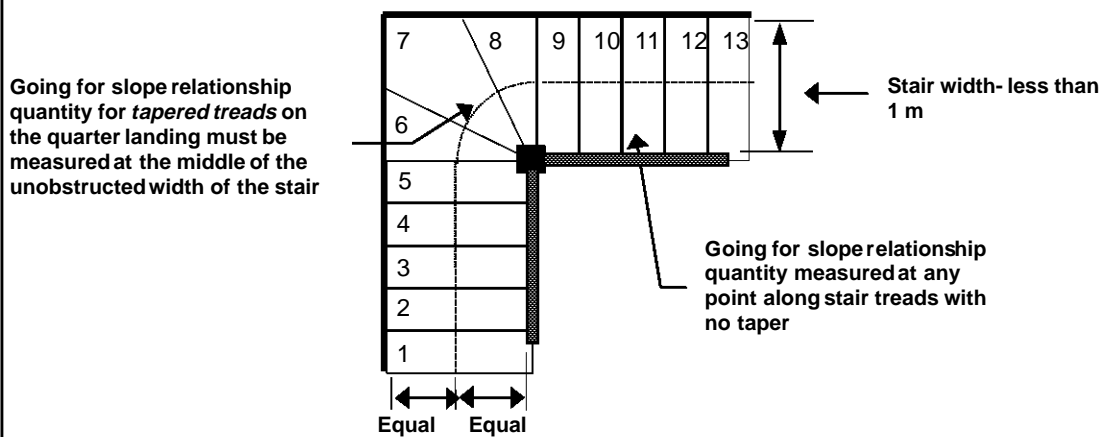
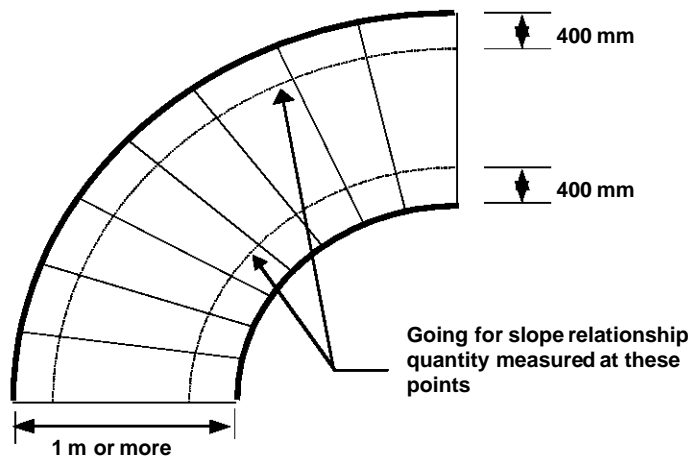

Diagram c. Tapered treads - 1 m or more in width



Amdt 3

Figure 3.9.1.4
SPIRAL STAIRS

Note: *Spiral stairs* must not have an unobstructed width of more than 1 m wide.

Diagram a. Measurement for slope relationship

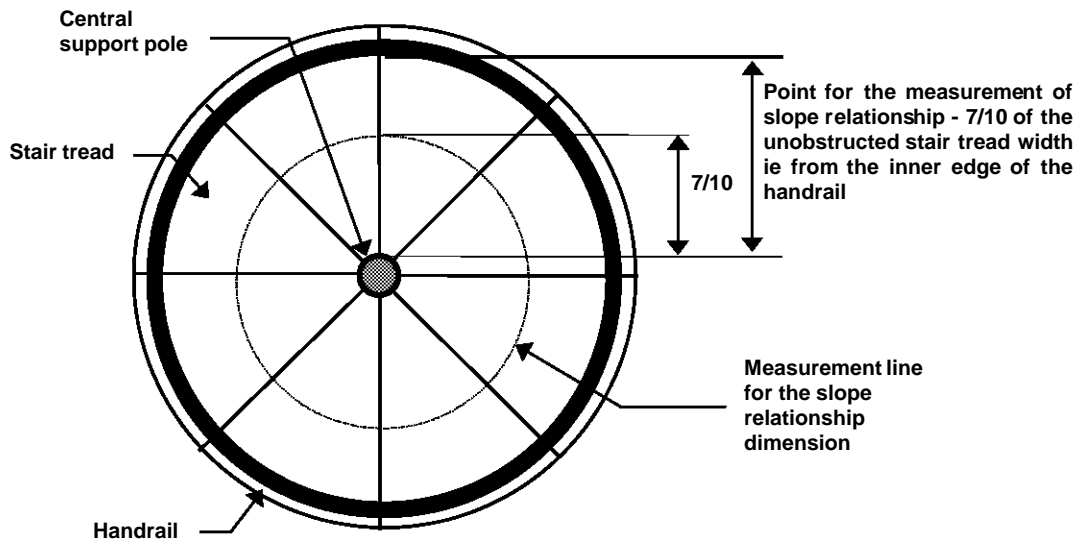
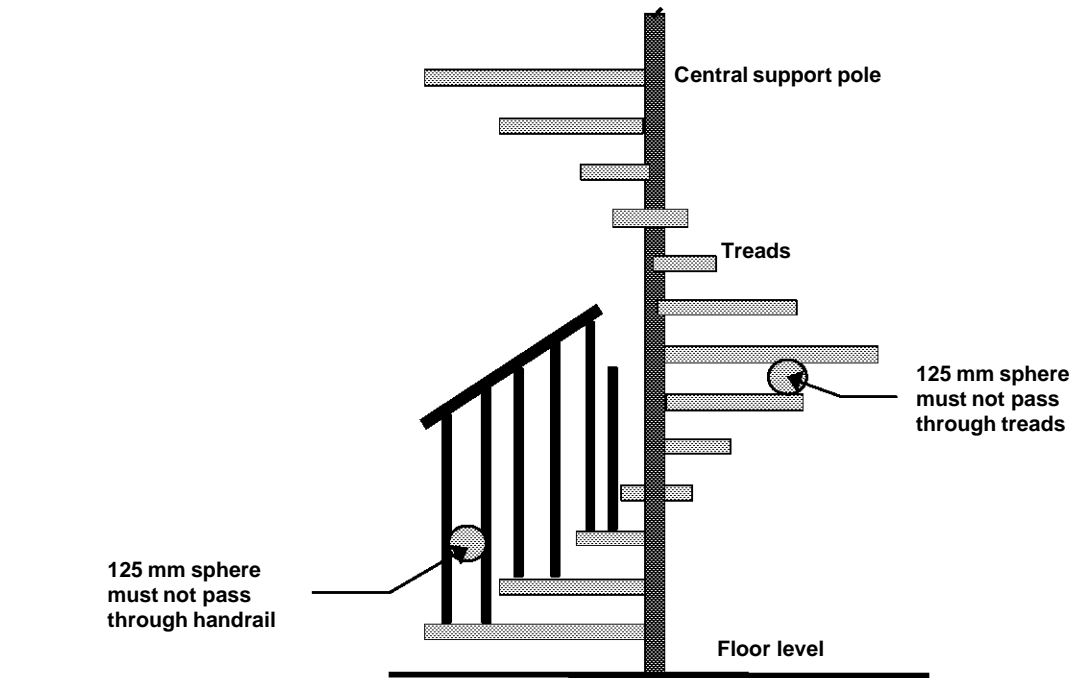

Diagram b. Measurement for openings in stairs



Amdt 3

Explanatory Information:

Tolerance values

The following tolerance values to the nominal dimension in Figure 3.9.1.2 may be applied where conditions such as movement of materials due to atmospheric moisture changes (ie cupping of timber stair treads) or change in adjacent floor covering specifications effect finished stair dimensions. They should not be applied to allow for poor construction practice.

Suitable tolerance values for stair dimensions

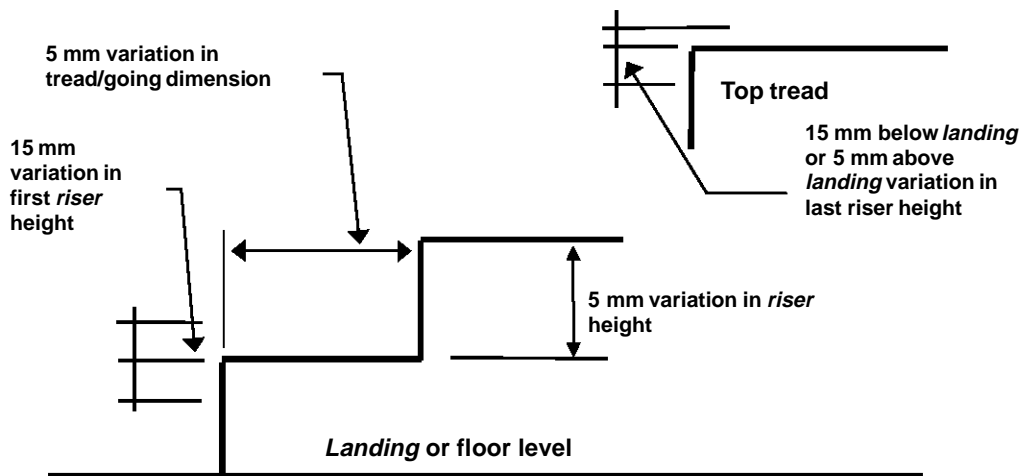

Amdt 3

3.9.1.5 Thresholds

The threshold of a doorway must not incorporate a step or ramp at any point closer to the doorway than the width of the door leaf unless the door sill is not more than 190 mm above the finished surface of the ground, balcony, or the like to which the doorway opens.

PART 3.9.2 BALUSTRADES

Appropriate *Performance Requirements*

Where an alternative balustrade or other barrier is proposed to that described in Part 3.9.2, that proposal must comply with the following *Performance Requirements* P2.1 and P2.5.2 in Section 2:

Acceptable construction practice

3.9.2.1 Application

3.9.2.1
Amdt No. 3

Compliance with this Part satisfies *Performance Requirement* P2.5.2 for balustrades or other barriers.

3.9.2.2 When balustrades or other barriers are required

3.9.2.2
Amdt No. 3

- (a) A continuous balustrade or other barrier must be provided along the side of any roof to which public access is provided, any stairway or ramp, any floor, corridor, hallway, balcony, verandah, mezzanine, access bridge or the like and along the side of any path of access to a building, if-
- (i) it is not bounded by a wall; and
 - (ii) any level is more than 1 m above the adjoining floor or finished ground level (see Figure 3.9.2.3).
- (b) The requirements of (a) do not apply to a *window* opening.

3.9.2.3 Balustrade or other barrier construction

3.9.2.3
Amdt No. 3

- (a) The height of a balustrade or other barrier must be in accordance with the following:
- (i) The height must not be less than 865 mm above the nosings of the stair treads or the floor of a ramp.
 - (ii) The height must not be less than-
 - (A) 1 m above the floor of any access path, balcony, *landing* or the like (see Figure 3.9.2.1); or
 - (B) 865 mm above the floor of a *landing* to a stair or ramp where the balustrade or other barrier is provided along the inside edge of the *landing* and is not more than 500 mm long.
- (b) A transition zone may be incorporated where the balustrade or other barrier height changes from 865 mm on the stair *flight* or ramp to 1 m at the *landing* (see Figure 3.9.2.2).

- (c) Openings in balustrades (including decorative balustrades) or other barriers must be constructed so that any opening does not permit a 125 mm sphere to pass through it and for stairs, the space is tested above the nosing line.
- (d) A balustrade or other barrier must be designed to take loading forces in accordance with AS 1170.1.
- (e) For floors more than 4 m above the ground, any horizontal elements within the balustrade or other barrier between 150 mm and 760 mm above the floor must not facilitate climbing.

Figure 3.9.2.1

BALUSTRADE CONSTRUCTION

Note: For the purposes of this Figure, a 125 mm sphere must not pass between rails or through the gap when tested above the nosing line.

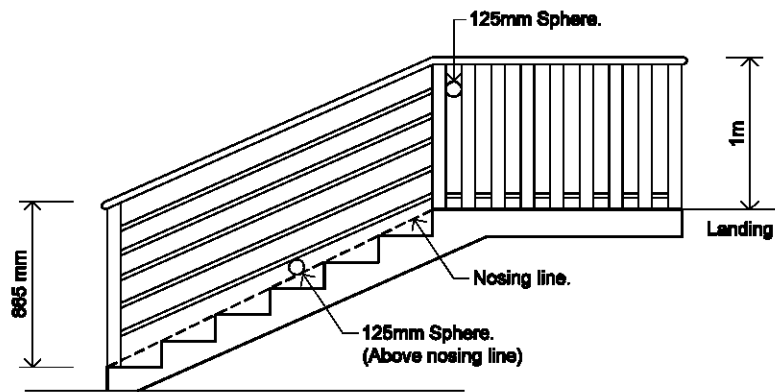

Figure 3.9.2.2

TRANSITION ZONES

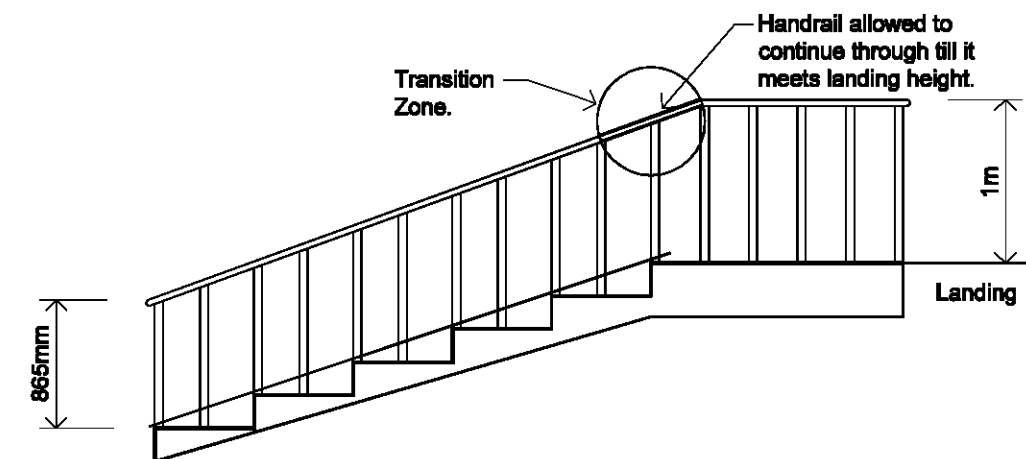
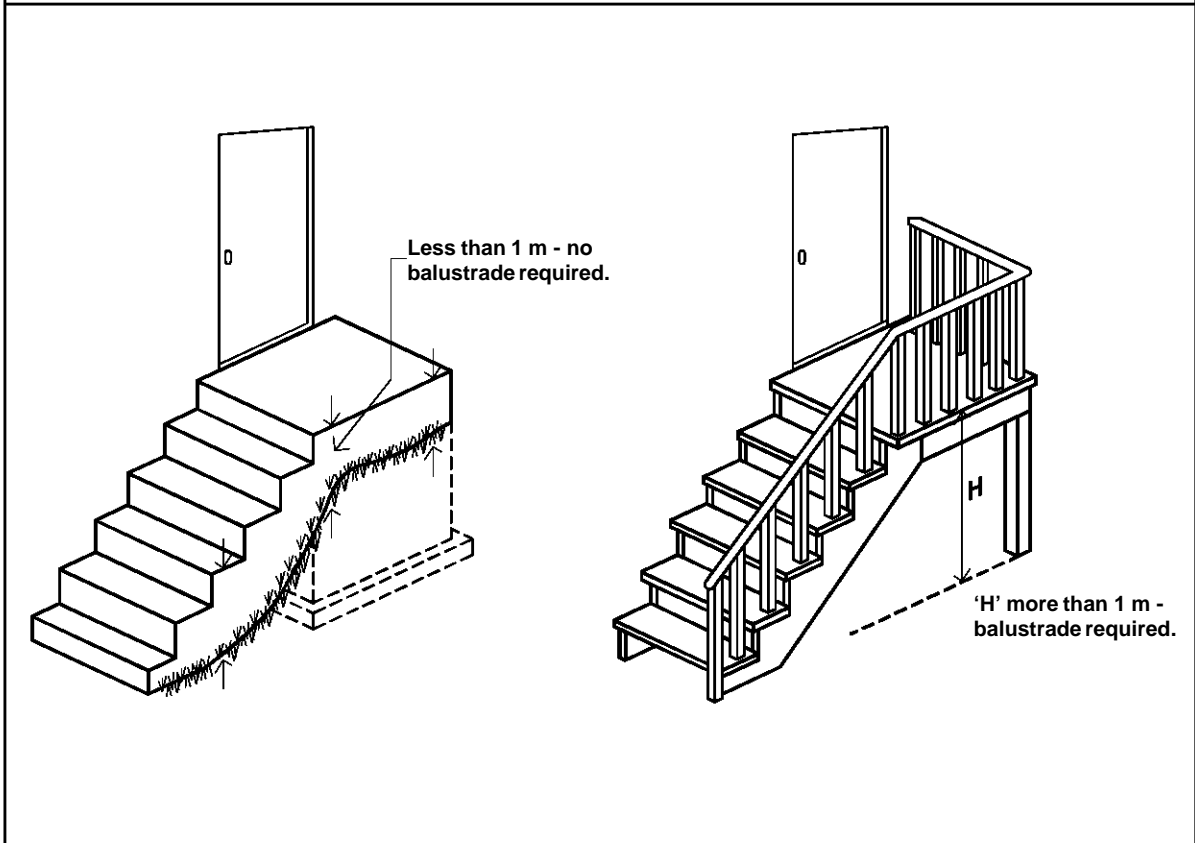

Figure 3.9.2.3
BALUSTRADES - WHEN REQUIRED



Amdt 3

PART 3.9.3 SWIMMING POOL ACCESS

Appropriate Performance Requirements:

Where an alternative *swimming pool* safety fence is proposed to that described in Part 3.9.3, that proposal must comply with *Performance Requirement P2.5.3* in Section 2.

STATE AND TERRITORY VARIATIONS

1. **Part 3.9.3 does not apply in New South Wales.**
Note: Restriction of access to *swimming pools* in New South Wales is regulated under the Swimming Pools Act 1992.
2. **Part 3.9.3 does not apply in Queensland.**
Note: Restriction of access to *swimming pools* in Queensland is regulated under the Building Act 1975.
3. **Part 3.9.3 does not apply in Western Australia.**
Note: Restriction of access to private *swimming pools* in Western Australia is regulated under the Local Government (Miscellaneous Provisions) Act 1960 and the Building Regulations 1989 as amended.
4. **Part 3.9.3 does not apply in the Northern Territory.**

A. Acceptable construction manual

3.9.3.0 *Performance Requirement P2.5.3* is satisfied for a *swimming pool* associated with a Class 1 building, with a depth of water more than 300 mm if it has safety fencing installed in accordance with AS 1926.1 - Swimming pool safety.

B. Acceptable construction practice

3.9.3.1 Application





Compliance with this Part satisfies *Performance Requirement P2.5.3* for *swimming pools* with a depth of water more than 300 mm, installed on allotments associated with Class 1 buildings.

3.9.3.2 Safety fencing location and construction

- (a) Safety fencing must be located in accordance with one of the options listed in Figure 3.9.3.1.
- (b) Safety fences and gates must comply with-
 - (i) for strength criteria - AS 1926.1; and
 - (ii) the appropriate dimension requirements described in Figures 3.9.3.2 to 3.9.3.5.

Figure 3.9.3.1
TYPICAL EXAMPLES OF SAFETY FENCING

Legend:

-  Gate complying with AS 1926.1
-  Fence, retaining wall or other barrier complying with AS 1926.1
-  Child resistant door or window complying with AS 1926.1
-  Allotment boundary

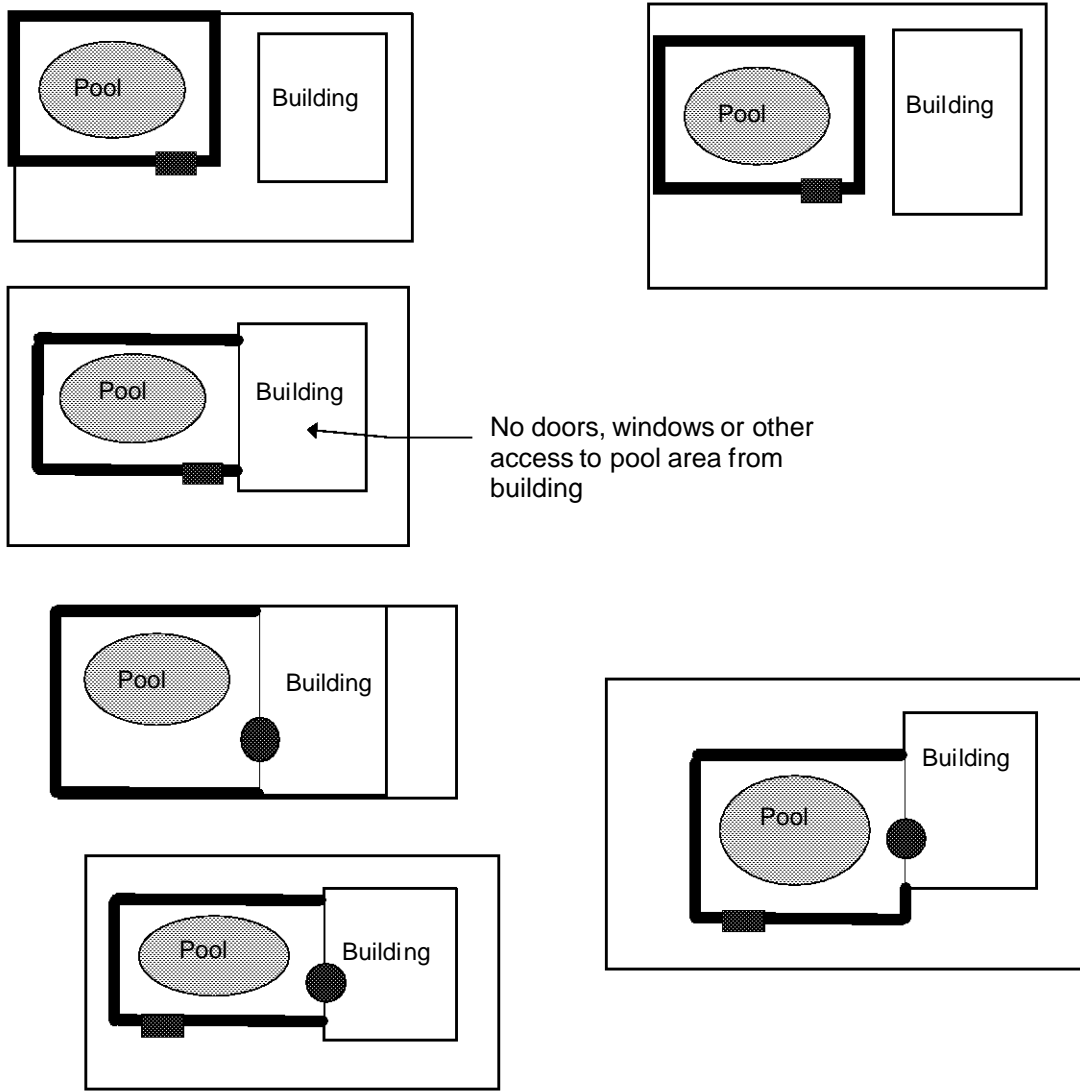

Amdt 3

Explanatory information:

Safety fencing should comprise of barriers or walls of sufficient height and designed and constructed without openings and footholds that would enable a young child to climb through or over the fence and provided with child-resistant self-closing and latching devices on gates and doors and if incorporating an external wall of a building any doors and openable windows to the pool area should be fitted with self-closing and latching devices that are child-resistant.

It should be noted that in NSW, Qld, WA and NT restriction of access to *swimming pools* is regulated under other legislation. ACT, Qld, SA and Tas impose additional requirements for *swimming pools* which may include provisions affecting the design of pools and pool surrounds, drainage of *swimming pools*, water recirculation and inlet and outlet openings and skimmer boxes and electrical installations.

The provisions of AS 1926.2 provide a number of options for the location of pool safety fencing. One option consists of enclosing the pool with isolation safety fencing completely separating the pool area from any other part of the allotment and any buildings. Alternatively the pool area should be separated from other parts of the allotment, any buildings and neighbouring allotments with barriers complying with the standards for safety fencing including the external wall of a building provided there is no access from the building to the pool area.

If access is provided from the building to the pool area any access door and window opening to the pool area must be protected with child-resistant doorsets and child-resistant openable portions of window.

Swimming pool safety fencing should be designed and constructed so as to be non-climbable by young children having regard to the height of the fence, any horizontal climbable members, openings and footholds in the fence and the operation of self-closing and latching gates.

Typical examples of satisfactory safety fencing are illustrated in AS 1926.1.

The operation of self-closing and latching devices on gates and doors should allow the gate or door to close and latch from any position, from resting on the latching mechanism to fully open.

STATE AND TERRITORY VARIATIONS

See ACT 6 for additional requirements for *swimming pool* construction.

See SA 4 for additional requirements for *swimming pool* construction.

See TAS 2 for additional requirements for *swimming pool* construction.

Figure 3.9.3.2

SPACING OF ACCESSIBLE HORIZONTAL MEMBERS, PROJECTIONS OR INDENTATIONS IN FENCING

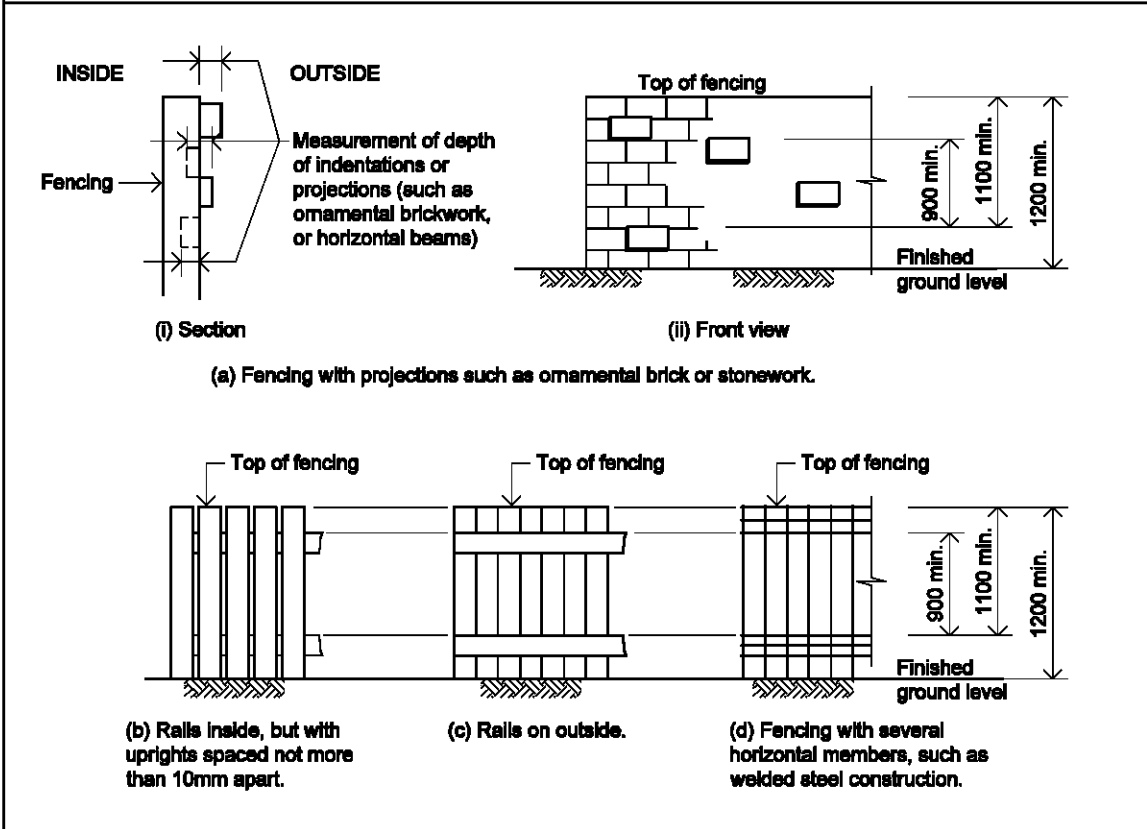

Amdt 3

Figure 3.9.3.3

CHAIN WIRE OR MESH FENCE

Note: Fencing material with an aperture more than 13 mm, but less than 100 mm.

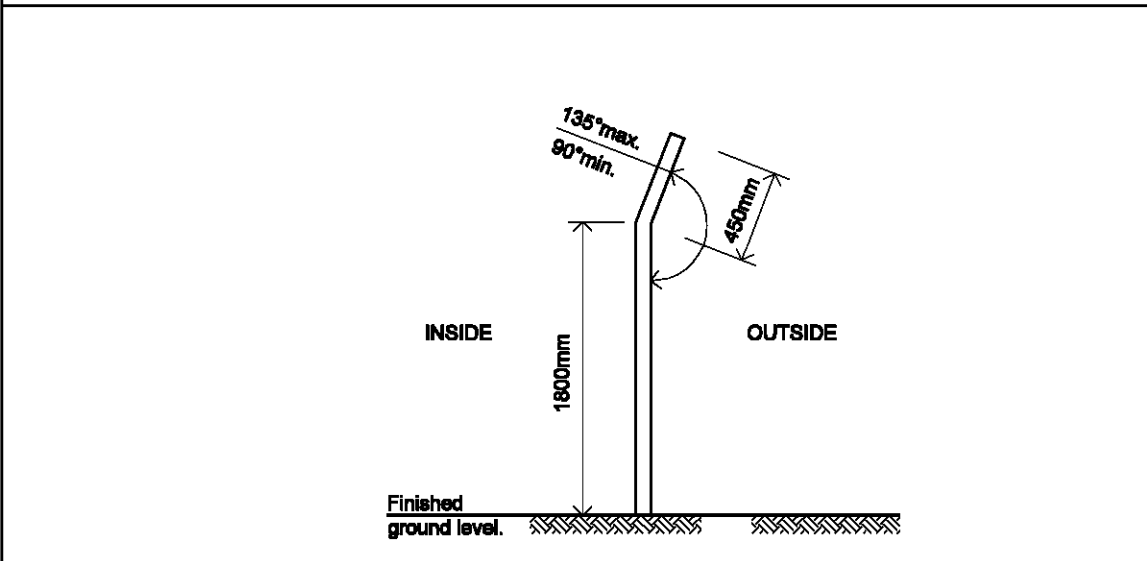
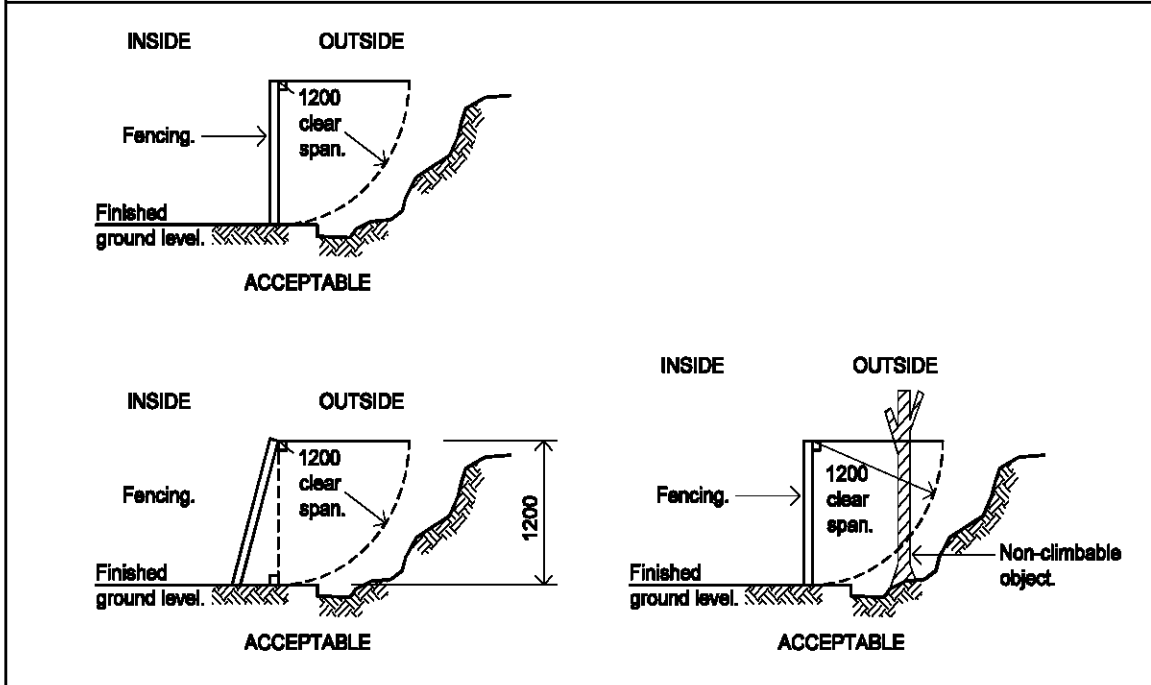
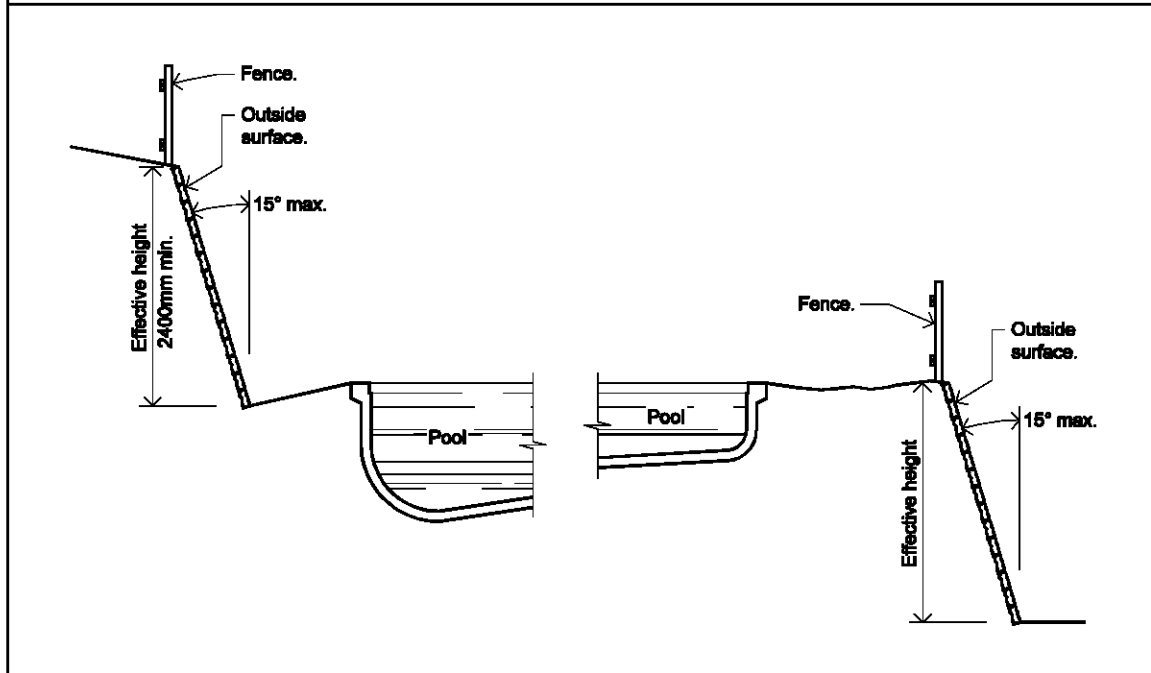

Figure 3.9.3.4
EFFECTIVE FENCING HEIGHT



Amdt 3

Figure 3.9.3.5
RETAINING WALLS AND OTHER SUCH BARRIERS



PART **3.10**

Amdt 3

**ADDITIONAL
CONSTRUCTION
REQUIREMENTS**

3.10.1 High Wind Areas

3.10.2 Earthquake Areas

PART 3.10 CONTENTS

		Page
3.10.1	High wind areas	23,021
3.10.1.0	Acceptable construction manuals Explanatory information	
3.10.2	Earthquake areas	23,201
3.10.2	Definitions	
3.10.2.0	Acceptable construction manuals	
3.10.2.1	Application	
3.10.2.2	Construction requirements	
3.10.2.3	Construction for areas with an acceleration coefficient of 0.12 or more but less than 0.15	
3.10.2.4	Construction for areas with an acceleration coefficient of 0.15 or more	

Explanatory information:

These provisions have been introduced to address design requirements for increased structural loading conditions that may occur due to geographical, topographical or climatic conditions that are beyond the scope of the preceding Parts of the *Housing Provisions*.

These provisions are to be read in conjunction with the other relevant requirements of this code.

eg For masonry construction in Part 3.10.1, the walls will be required to be designed in accordance with AS 3700. However, the lintels, flashings and damp proof courses can be installed in accordance with Part 3.3.

PART 3.10.1 HIGH WIND AREAS

Appropriate Performance Requirements:

Where an alternative method of construction in *high wind areas* is proposed to that described in 3.10.1.0, that method must comply with *Performance Requirement P2.1* in Section 2.

Acceptable construction manuals

3.10.1.0 *Performance Requirement P2.1* is satisfied for a building constructed in a *high wind area* if it complies with one or more of the following manuals:

- (a) Masonry - AS 3700 Masonry Code.
- (b) The Northern Territory Deemed-to-Comply Standards Manual.
- (c) Timber-
 - (i) Timber Framing Manual W41C - Timber Research and Development Advisory Council - Queensland; or
 - (ii) Timber Framing Manual W50C - Timber Research and Development Advisory Council - Queensland; or
 - (iii) Timber Framing Manual W60C - Timber Research and Development Advisory Council - Queensland.
- (d) Steel-
 - (i) AS 1250 - The use of steel in structures; or
 - (ii) AS 3623 - Domestic metal framing; or
 - (iii) AS 4100 - Steel framing.
- (e) Glazing - external glazing is designed and installed in accordance with AS 1288.

STATE AND TERRITORY VARIATIONS

Add 3.10.1.0 (f) and (g) in the Northern Territory.

- (f) Metal clad roofing
Test for strength - Metal roofing and its fitments should be capable of withstanding without failure, the test application of 10,000 cycles of working load from zero to that maximum at a rate of 3 Hz, followed by a static load test of 1.8 times the working load.
- (g) Masonry veneer - masonry veneer construction must be designed so that the structural framing to which the masonry veneer is tied, will ensure the stability of the masonry veneer.

3.10.1.0(g)
Amdt No. 2

Figure 3.10.1.4
CYCLONIC AREAS

Note: High wind areas exist outside the cyclonic regions indicated on this map.

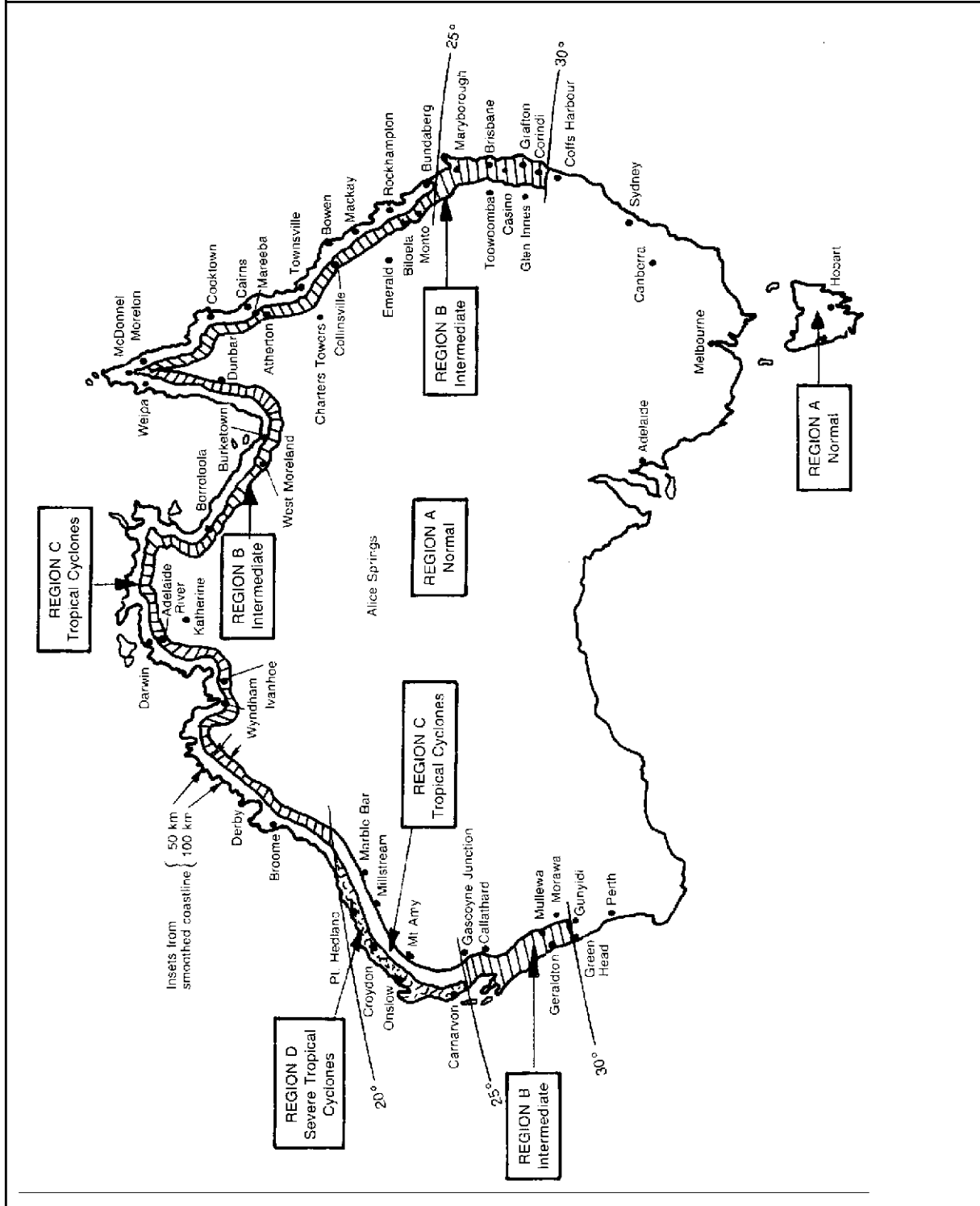

Amdt 3

Explanatory Information: Construction in *high wind areas*

The intent of building construction in *high wind areas* is to ensure the structure has sufficient strength to transfer wind forces to the ground with an adequate safety margin to prevent the collapse of the building and the building being lifted, or slid off its foundations.

To resist these forces it is necessary to have-

- (a) an anchorage system, where the roof is connected by the walls to the footings by a chain of connections; and
- (b) a bracing system to prevent horizontal collapse due to wind forces; and
- (c) continuity of the system where each structural element is interlocked to its adjoining structural element throughout the building.

Anchorage

Anchorage of the system is achieved by using a variety of proprietary connectors. Each connector must be capable of carrying the uplift force, because the ability of the building to resist the wind forces is directly related to its weakest link.

Acceptable construction manuals to achieve these requirements are described in this Part.

PART 3.10.2 EARTHQUAKE AREAS

Appropriate *Performance Requirements*:

Where an alternative design is proposed to that described in Part 3.10.2, that proposal must comply with *Performance Requirement P2.1* in Section 2.

Definitions

3.10.2 The following definitions are used in this Part:

Acceleration coefficient means an index related to the expected severity of earthquake ground motion, as determined under AS 1170.4 and described in Figure 3.10.2.1.

Design category: means the *design category* given in Table 2.6 of AS 1170.4. Domestic structures are separated into three earthquake design categories H1, H2 and H3 in order of increasing potential to be damaged by earthquake loads.

Framing connector means a manufactured connector system for timber joints formed from 1.2 mm minimum thickness galvanised steel and punched to take nails.

A. Acceptable construction manuals

3.10.2.0 *Performance Requirement P2.1* for Class 1 and 10 buildings constructed in areas subject to seismic activity is satisfied if the building is constructed in accordance with the applicable construction manuals listed in Part 3.11.

Explanatory Information:

Most domestic structures are not required to be specifically designed for earthquakes, because the construction system already in place for wind resistance is usually adequate for earthquake resistance.

Accordingly, compliance with other acceptable construction details in the *Housing Provisions* are suitable for areas with an acceleration co-efficient below 0.12 provided the building is built in an area that is not considered to be complying with a structural *design category* of H3 as defined in AS 1170.4.

Class H3 are typically *sites* identified as having soft soil (having a soil profile with more than 5 m of soft clay, loose sand, silt or uncontrolled fill) which need to be designed in accordance with Part 3.11.

B. Acceptable construction practice**3.10.2.1 Application**3.10.2.1
Amdt No. 2

Compliance with this Part for Class 1 and 10 buildings constructed in areas with a seismic activity *acceleration coefficient* of 0.12 or more satisfies *performance requirement* P2.1, provided-

- (a) the soil profile of the *site* does not have more than 5 m of soft clay, loose sand, silt or uncontrolled fill; and
- (b) the buildings-
 - (i) have a rise in storeys not more than 1; and
 - (ii) do not have-
 - (A) a roof clad with concrete or terracotta tiles; or
 - (B) masonry projections or overhangs, masonry parapets or unbraced masonry chimneys.

3.10.2.2 Construction requirements

Construction in earthquake areas must comply with the following:

- (a) In locations with an *acceleration coefficient* of 0.12 or more but less than 0.15, a Class 1 and 10 building must comply with 3.10.2.3.
- (b) In locations with an *acceleration coefficient* of 0.15 or more, a Class 1 and 10 building must comply with 3.10.2.4.
- (c) See Figure 3.10.2.1 for *acceleration co-efficient* design values.

Explanatory Information:

The principal requirement for structural detailing in domestic structures is that each of the system components are sufficiently connected together such that the forces generated by an earthquake are carried to the foundation.

Trusses, beams and the like should be restrained horizontally at their support, and for this purpose, framing connectors are sufficient.

Bracing requirements, in horizontal and vertical directions, are the same as for wind loads.

Figure 3.10.2.1
ACCELERATION CO-EFFICIENT MAP OF AUSTRALIA

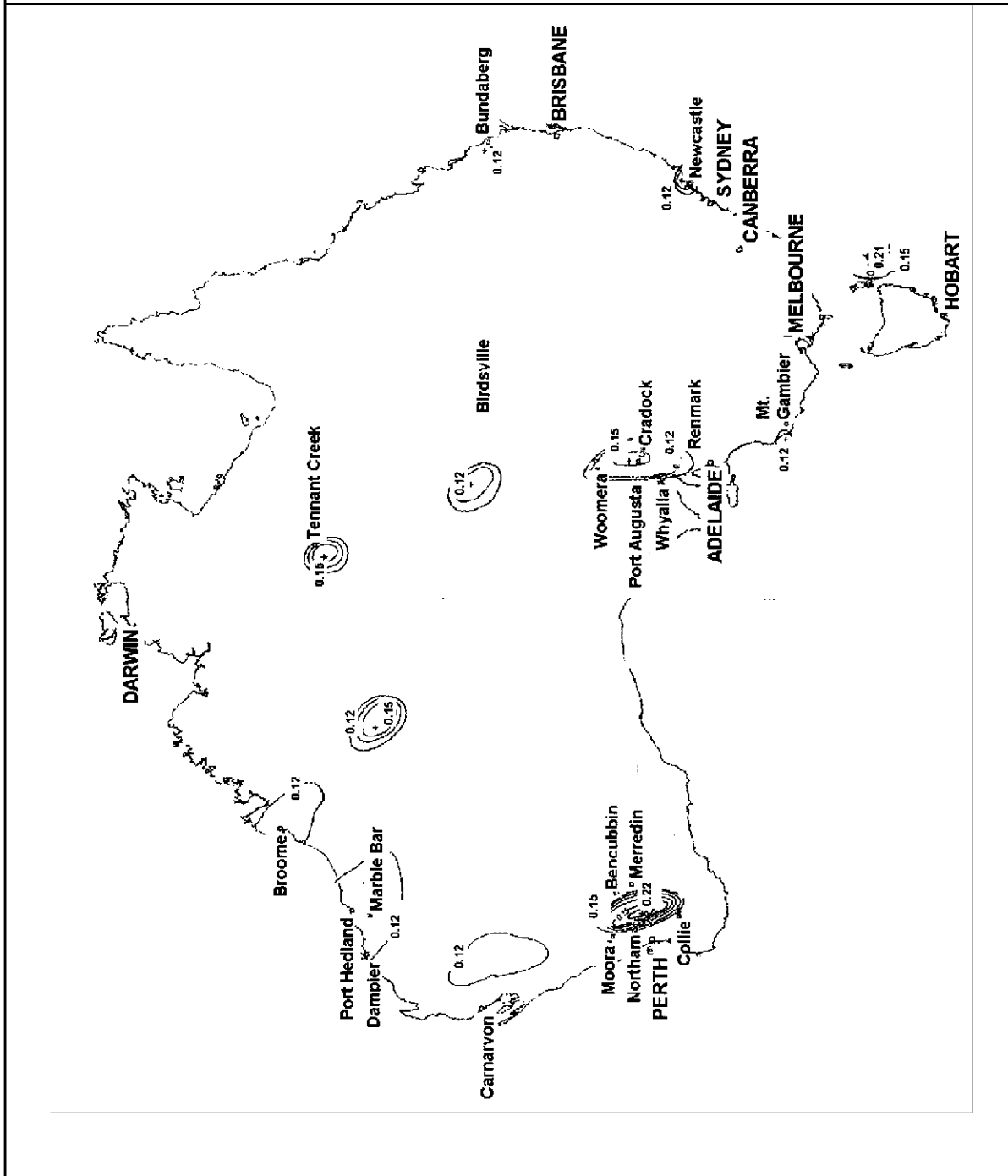

Amdt 3

3.10.2.3 Construction for areas with an acceleration coefficient of 0.12 or more but less than 0.153.10.2.3
Amdt No. 2

Buildings in areas with an *acceleration coefficient* of 0.12 or more but less than 0.15 must be constructed as follows:

- (a) Footings must comply with the appropriate provisions of Part 3.2 and the additional requirements of this clause:
- (i) Stumps must be steel, timber or reinforced concrete.
 - (ii) Bracing to stumps must be connected with galvanised M12 bolts or equivalent to comply with AS 1684-
 - (A) at not more than 10 m intervals; and
 - (B) at corner stumps - in two directions.
 - (C) to every stump projecting more than 650 mm out of the ground.
 - (iii) Floor beams must be fixed to the top of stumps with two M10 diameter bolts or equivalent fixing.
 - (iv) Bottom plates of framed structures, where fixed to a concrete slab or strip footing must be fixed with M10 bolts or masonry anchors at not more than 1.2 m centres.
 - (v) Concrete strip footings must be continuously reinforced with two layers of reinforcement comprising two 12 mm diameter bars (Grade 400Y) per layer and tied with R6 ligatures at centres not more than 2.5 times the depth of the footing.
 - (vi) Raft slabs must incorporate monolithic edge beams.
- (b) Framed wall construction must comply with the appropriate provisions of Part 3.4 and the additional requirements of this clause:

3.10.2.3
(b)(i)(A)
Amdt No. 3

- (i) Metal framing must-
 - (A) comply with Part 3.4, AS 1538 or AS/NZS 1664; or AS/NZS 1664.2; and
 - (B) be not less than 1.2 mm thick (other than bracing); and
 - (C) have wall plates that are continuous between cross walls or spliced to maintain strength.

3.10.2.3
(b)(ii)(B)
Amdt No. 3

- (ii) Timber framing-
 - (A) must be fixed with timber *framing connectors* nailed with not less than three 2.8 mm diameter x 30 mm long nails to each fixing plate or the connector; and
 - (B) must be constructed of seasoned timber, fixed with at least two 2.8 mm diameter nails, machine nailed through the top or bottom wall plate into the stud; and

- (C) wall plates must be continuous between cross walls or spliced to maintain strength.
- (c) *Unreinforced masonry* must comply with the appropriate provisions of Part 3.3 and the additional requirements of this clause:
- (i) Internal or *external walls* 4 m or more in length must be stiffened by cross walls, columns or bracing complying with AS 1170.4 and AS 3700; and-
- (A) cross walls must be tied to the internal leaf of *cavity walls* by fully bonding or by metal ties at every second course; and
- (B) the mortar mix must be at least as strong as a 1:1:6; and
- (C) masonry units must have good mortar adherence properties.
- (ii) Bricks must-
- (A) be laid on a full bed joint with full perpend; and
- (B) when laid in the top two courses of internal walls and the internal leaf of *external walls*, contain no perforations.
- (iii) Reinforcement consisting of two R6 bars (Grade 250R), or two 3.15 mm diameter bars (Grade 450W), must-
- (A) be placed in both leaves of *external walls* in the course immediately under *window sills* and over door and *window heads*; and
- (B) be galvanised when placed in the external leaf of an *external wall*; and
- (C) extend not less than 300 mm beyond any supporting cross walls or columns; and
- (D) be spliced not less than 300 mm.
- (iv) Continuous reinforced brick bond beams must be installed, comprising two R6 bars (Grade 250R), or two 3.15 mm diameter bars (Grade 450W), in each of the top three bed joints, constructed-
- (A) on the internal leaf of all *external walls* and on all cross walls; and
- (B) where the roof is pitched on the external leaf of an *external wall*, in that external leaf; and
- (C) in cross walls, turned and lapped 300 mm into the *external walls*.
- (viii) Top wall plates must be fixed by masonry anchors or equivalent fixing connected to the second top course of walls, at not more than 1.8 m centres.
- (d) Veneers that comprise an external leaf of masonry connected to internal walls of timber or metal framing must be fixed in accordance with AS 3700.

- (e) Roof framing must comply with the appropriate provisions of Part 3.4: and-
 - (i) be fixed to the top wall plate using *timber framing connectors* nailed with not less than three 2.8 mm diameter x 30 mm long nails to each fixing plate of the connector; and
 - (ii) incorporate roof bracing to transfer all horizontal loads directly to cross walls.

3.10.2.4 Construction for areas with an acceleration coefficient of 0.15 or more

Buildings in areas with an *acceleration coefficient* of 0.15 or more must be constructed as follows:

- (a) Footings must comply with the appropriate provisions of Part 3.2 and the additional requirements of this clause:
 - (i) Stumps must be steel, timber or reinforced concrete.
 - (ii) Bracing to stumps must be connected with galvanised M12 bolts or equivalent to comply with AS 1684-
 - (A) at not more than 8 m intervals; and
 - (B) at corner stumps - in two directions; and
 - (C) to every stump projecting more than 500 mm out of the ground.
 - (iii) Floor beams must be fixed to the top of stumps with two M10 diameter bolts or equivalent fixing.
 - (iv) Bottom plates of framed structures where fixed to a concrete raft or strip footing must be fixed with M10 bolts or masonry anchors at not more than 1.2 m centres.
 - (v) Concrete strip footings must be continuously reinforced with two layers of reinforcement comprising two 12 mm diameter bars (Grade 400Y) per layer and tied with R6 ligatures at centres not more than 2.5 times the depth of the footing.
 - (vi) Raft slabs must incorporate monolithic edge beams.
- (b) Framed wall construction must comply with the appropriate provisions of Part 3.4 and the additional requirements of this clause:
 - (i) Metal framing-
 - (A) must comply with Part 3.4, AS 1538 or AS 1664; and
 - (B) must be not less than 1.2 mm thick (other than bracing); and
 - (C) wall plates must be continuous between cross walls or spliced to maintain strength.
 - (ii) Timber framing must comply with the following-

- (A) *Timber framing connectors* must be nailed with not less than three 2.8 mm diameter x 30 mm long nails to each fixing plate or the connector.
 - (B) Seasoned timber, must be fixed with not less than two 2.8 mm diameter nails, machine nailed through the top or bottom wall plate into the stud.
 - (C) Wall plates must be continuous between cross walls or spliced to maintain strength.
- (c) Veneer on frame construction must comply with the following:
- (i) Veneers that comprise an external leaf of masonry connected to internal walls of timber or metal framing must be fixed in accordance with AS 3700.
 - (ii) Timber framing:
 - (A) Wall plates must be-
 - (aa) fixed to transfer lateral loads between frames of *external walls* and frames of internal walls; and
 - (bb) at least F8 grade timber having dimensions not less than 100x 50 mm where cross walls are spaced at not more than 4.8 m centres.
 - (B) *External walls* must be fixed to supporting cross walls at or near top wall plate level by not less than two *framing connectors* with not less than three 2.8 mm diameter nails to each plate of the connector or by bolting the frames together with M10 minimum diameter bolts.
 - (iii) Metal framing:
 - (A) Wall plates must-
 - (aa) be fixed to transfer lateral loads between frames of *external walls* and frames of internal walls; and
 - (bb) have minimum dimensions of 78x31x1.2 mm where cross walls are spaced at not more than 5.5 m centres, and stiffened by an additional 75x78x1.6 mm plate where the span is more than 3.5 m.
 - (B) *External walls* must be fixed to supporting cross walls at or near top wall plate level by at least two *timber framing connectors* or by bolting the frames together with M10 minimum diameter bolts.
 - (iv) The veneer of *external walls* must be fixed to the frame with 100x100 mm galvanised steel mesh.
 - (v) Masonry veneer must not be placed over openings or in gables.

- (d) Roof framing must comply with the appropriate provisions of Part 3.4; and
 - (i) incorporate roof bracing to transfer all horizontal loads directly to cross walls; and
 - (ii) be fixed to the top wall plate using timber *framing connectors* nailed with at least three 2.8 mm diameter x 30 mm long nails to each fixing plate of the connector.

PART **3.11**

Amdt 3

STRUCTURAL DESIGN MANUALS

- 3.11.1 Application
- 3.11.2 Acceptable Structural Design Manuals
- 3.11.3 Loading Requirements
- 3.11.4 Structural Design Manuals

PART 3.11 CONTENTS

		Page
3.11	Acceptable construction manuals	25,021
3.11.1	Application	
3.11.2	Acceptable structural design manuals	
3.11.3	Loading requirements	
3.11.4	Structural design manuals	

Explanatory information:

This Part of the *Housing Provisions* contains a list of deemed-to-satisfy codes (structural design manuals) that can be used to design building elements using engineering principles.

These provisions can be used in conjunction with both the *Performance Requirements* (listed in Section 2) and the *Deemed-to-Satisfy Provisions* (listed in Section 3 - Parts 1 to 11). This combined approach is acceptable and meets the requirements of the *Housing Provisions*.

PART 3.11 STRUCTURAL DESIGN MANUALS

Appropriate *Performance Requirements*

Where it is proposed to use an alternative structural design manual to that described in Part 3.11, that proposal must comply with *Performance Requirement* P2.1 in Section 2.

Acceptable construction manuals

3.11.1 Application

Compliance with the provisions of this Part satisfies *Performance Requirement* P2.1 provided the building is designed and built in accordance with-

- (a) 3.11.2; or
- (b) the relevant provisions of other Parts of Section 3 of the *Housing Provisions* relating to structural elements; or
- (c) a combination of (a) or (b).

3.11.2 Acceptable structural design manuals

A Class 1 and 10 building must be designed-

- (a) to resist the loads determined in accordance with the appropriate aspects of the design codes described in 3.11.3; and
- (b) in accordance with the appropriate structural design code listed in 3.11.4.

3.11.3 Loading requirements

A Class 1 and 10 building must be designed to resist loads as determined in accordance with the following design codes as appropriate:

- (a) Dead and live loads and load combinations - AS 1170.1.
- (b) Wind loads - AS 1170.2 or AS 4055.
- (c) Snow loads - AS 1170.3 .
- (d) Earthquake loads - AS 1170.4.

3.11.4 Structural design manuals

The design of buildings or structural elements in a building must be in accordance with one, or any combination of, the following codes as appropriate:

- (a) Steel construction:
- (i) AS 1250 - The use of steel in structures.
 - (ii) AS 1538 - Cold formed steel structures.
 - (iii) AS 3623 - Domestic metal framing.
 - (iv) AS 4100 - Steel structures.
- (b) Aluminium construction:
- (i) AS/NZS 1664 – Aluminium structures, Part 1 – Limit state design.
 - (ii) AS/NZS 1664 – Aluminium structures, Part 2 – Allowable stress design.
- (c) Timber construction:
AS 1720.1 - Timber structures code.
- (d) Footings:
- (i) AS 2870 - Residential slabs and footings.
 - (ii) AS 3600 - Concrete structures.
- (e) Piling:
AS 2159 - Piling - Design and information.
- (f) Concrete construction (including reinforced and prestressed concrete):
AS 3600 - Concrete structures.
- (g) Masonry (including masonry-veneer, *unreinforced masonry* and *reinforced masonry*):
AS 3700 - SAA Masonry code.
- (h) Composite steel and concrete:
AS 2327.1 - Composite construction in steel and concrete.
- (i) Glass installations:
AS 1288 - Glass in buildings - Selection and Installation.
- (j) Earthwall construction:
NBTC Bulletin 5, Edition 4.
- (k) Structures for primary production purposes in rural areas:
AS 2867 - Farm structures - General requirements for structural design.

3.11.4(b)
Amdt No. 3

Amdt 3

APPENDIX **A**

STATE AND TERRITORY ADDITIONS

Australian Capital Territory

New South Wales

Northern Territory

Queensland

South Australia

Tasmania

Victoria

Western Australia

APPENDIX **A** - STATE AND TERRITORY ADDITIONS

CONTENTS	Page
AUSTRALIAN CAPITAL TERRITORY	50,021
Structure	
ACT 1 - * * * * *	
Health and amenity	
ACT 2 - Hazardous materials	
ACT 3 - Control of Litter on Building Sites	
ACT 4 - Waste Management	
ACT 5 - Energy Efficiency	
Safe movement and access	
ACT 6 - Swimming pools	
NEW SOUTH WALES - No additional provisions	50,201
NORTHERN TERRITORY - No additional provisions	50,401
QUEENSLAND -	50,601
Health and amenity	
QLD 1 - * * * * *	
QLD 2 - Flashing of narrow spaces and vermin control	
SOUTH AUSTRALIA	50,801
Acceptable construction manual	
SA 1 - Application	
Fire safety	
SA 2 - * * * * *	
Health and amenity	
SA 3 - Wet areas	
Safe movement and access -	
SA 4 - Swimming pool safety	
SA 5 - Access for people with disabilities	
SA 6 - Access for inspection and maintenance	

Continued next page

Amdt 3

TASMANIA	51,001
Fire safety	
TAS 1 - Non combustible roofing	
Safe movement and access	
TAS 2 - Swimming pool water reticulation and filtration	
VICTORIA	51,201
Health and amenity	
VIC 1 - Thermal insulation	
Special requirements for certain buildings and components	
WESTERN AUSTRALIA- No additional provisions	51,401

Amdt 3

AUSTRALIAN CAPITAL TERRITORY ADDITIONS

Application of Australian Capital Territory additions

This Appendix contains additional provisions for application in the Australian Capital Territory as follows:

ACT 1 - * * * * *

ACT1
Amdt No. 3

This clause has been deliberately left blank.

Amdt 3

HEALTH AND AMENITY

ACT 2 - HAZARDOUS MATERIALS

ACT 2.1 PERFORMANCE PROVISIONS

Objective

The *Objective* is to safeguard people from illness resulting from exposure to asbestos building materials during removal and disposal.

Functional Statement

Asbestos building material shall be removed and disposed of in a safe manner.

Performance Requirement

When asbestos-based material in any form or in any mixture thereof, or any material containing loose asbestos including asbestos fluff insulation, asbestos sheeting, lagging, fire protection and the like is removed, it must be handled and disposed of safely.

ACT 2.2 ACCEPTABLE CONSTRUCTION PRACTICE

The requirements of ACT P2 are satisfied when asbestos-based materials are handled and disposed of in accordance with the Worksafe Australia Code of Practice and Guidance Notes.

ACT 3 - CONTROL OF LITTER ON BUILDING SITES**ACT 3.1 PERFORMANCE PROVISIONS****Objective**

The *Objective* of this provision is to prevent wind blown litter from building sites fouling roads and public land.

Functional Statement

Building litter must be prevented from spreading around the site and beyond the site boundary.

Performance Requirement

Sufficient containers must be provided on building sites to store building waste that is likely to become windblown.

ACT 3.2 ACCEPTABLE CONSTRUCTION PRACTICE

The requirements of ACT P3 are satisfied by:

On site building waste that is stored in suitable size plastic or metal bins and removed from the site at regular intervals.

Note: Building Waste includes: plastic containers and plastic and paper wrappings or any waste that can be carried by wind.

ACT 4 - WASTE MANAGEMENT**ACT 4.1 PERFORMANCE PROVISIONS****Objective**

The *Objective* of this provision is to safeguard people from injury caused by infection or contamination from solid waste.

Functional Statement

Buildings must be provided with space and facilities for the collection, and safe hygienic holding prior to disposal of solid waste arising from the intended use of the building.

Performance Requirement

Where provision is made within buildings for the collection and temporary holding of solid waste. The design shall accommodate screening, volume of waste, disposal, logistics and access

ACT 4.2 ACCEPTABLE CONSTRUCTION PRACTICE

The requirements of ACT P4 are satisfied by garbage facilities that are designed and constructed in accordance with the ACT Waste Management Design Guide.

ACT 5- ENERGY EFFICIENCY**Limitation:**

ACT 5 applies to Class 1 buildings only.

ACT 5.1 PERFORMANCE PROVISIONS**Objective**

The *Objective* is to facilitate efficient use of energy in buildings.

Functional Statement

Buildings must be designed to ensure efficient energy use.

Performance Requirement

A building including carpets and internal fittings must achieve an annual energy consumption rate for heating and cooling not greater than 255 Megajoules/m based on the ACT climate zone.

Limitation:

ACT P5 applies to Class 1 buildings only.

ACT 5.2 ACCEPTABLE CONSTRUCTION PRACTICE**ACT 5.2.1 - Energy efficiency**

The requirements of ACT P5 are satisfied by-

- (a) a building that achieves an ACT House Energy Rating of 4 Stars as assessed by an accredited ACT House Energy Assessor or;
- (b) by any other assessment method, satisfying P5; and
- (c) an addition-
 - (i) complying with P5 or (a); or
 - (ii) fully insulated in accordance with ACT Table 1 and the floor is concrete; or the timber floor has an R rating of 1 including carpets.

<p>ACT Table 1 MINIMUM INSULATION MATERIAL</p>
--

<p>Roofs</p>

- | |
|---|
| <p>(a) R3 insulation material in the ceiling space; or
(b) R2 insulation material in exposed raked ceiling (concession)</p> |
|---|

<p>Walls</p>

<p>R1.5 insulation material in the external wall space</p>
--

Amdt 3

ACT 5.2.2 Exemptions

<p>ACT 5.2.2 Amdt No. 3</p>

The requirements of this Part do not apply to the following types of construction:

- (a) cavity brick, earthwall construction, ashlar stone or other masonry walls which have a thickness (excluding any cavity) of not less than 180 mm do not require wall insulation.
- (b) Class 10 structures forming part of a Class 1 building.
- (c) Moveable dwellings and mobile homes where their form of prefabricated construction does not readily permit achievement of optimal insulation requirements.

ACT 5.2.3 Fire resistance of insulation materials

When tested in accordance with AS 1530.3 a thermal insulation material must have a *Spread-of-Flame Index* of 0 and a *Smoke-Developed Index* not greater than 4.

<p>ACT 6 - SWIMMING POOL CONSTRUCTION</p>
--

<p>Application:</p>

<p>This requirement is to be applied in conjunction with Part 3.9.3</p>

ACT 6.1 Swimming pool construction

Indoor or outdoor permanent bathing, wading and *swimming pools* must-

- (a) where the capacity of the pool exceeds 10 m³
 - (i) be of the recirculation type in which the water circulation is maintained through the pool by pumps, the water drawn from the pool being clarified and disinfected before being returned to the pool; and

-
- (ii) have an outlet sump with antivortex cover or grating and have a skimming weir or overflow gutter or channel at high water level; and
 - (iii) have means of egress provided in the form of ladders, steps in the floor of the pool or a ramp; and
 - (b) be capable of being completely emptied and any discharge or overflow and pool backwash filter must be connected to the sewer drainage system; and
 - (c) be watertight with smooth surfaces of non-absorbent, non-slip material, light in colour and with rounded corners to facilitate cleaning; and
 - (d) have surrounding concourses graded away from the pool.

OTHER LEGISLATION AFFECTING BUILDINGS

In addition to the requirements of the ACT Building Act 1972 and the ACT Building Code, administered by ACT Building Electrical and Plumbing Control, (BEPCON) builders and designers should be aware of other legislation which contains building requirements.

The following is a list of some of the other relevant legislation:

1. **Health Legislation**
Public Health (General Sanitation) Regulations (ACT Health and Community services)
2. **Environmental Control and Emission Standards**
Air Pollution Act 1984 (Department of Urban Services) (DUS)
Noise Control Act 1988 (DUS)
Water Pollution Act 1984 (DUS)
3. **Occupational Health and Safety**
ACT Demolition Code of Practice (Chief Minister's Department) (CMD)
Occupational Health and Safety Act 1989 (CMD)
4. **Public Housing**
Housing Assistance Act 1987 (ACT Housing Trust)
5. **Scaffolding and Temporary Works**
Scaffolding and Lifts Regulations (CMD)
6. **Urban Design Standards, Land Title and Tenure**
ACT (Planning and Land Management) Act 1988 (National Capital Planning Authority) (NCPA)
City Area Leases Act 1936 (For leases before the Land Act commenced) (DUS)
Common Boundaries Act 1981 (DUS)
Land (Planning and Environment) Act 1991 (DUS)
Leases (Special Purposes) Act 1925 (For leases before the Land Act commenced) (DUS)
National Land Ordinance 1989 (NCPA)
Unit Titles Act 1970 (DUS)
7. **Utility Services and Urban Infrastructure**
Canberra Sewerage and Water Supply Regulations (ACT Building Electrical & Plumbing Control) (BEPCON)
Electricity Act 1971 (BEPCON)
Gas Act 1992 (AGL, Dangerous Goods Inspectorate)
Protection of Lands Act 1937 (DUS)
Roads and Public Places Act 1937 (DUS)

NEW SOUTH WALES ADDITIONS

New South Wales has no additions to the Housing Provisions.

NORTHERN TERRITORY ADDITIONS

The Northern Territory has no additions to the Housing Provisions.

QUEENSLAND ADDITIONS

Application of Queensland variations

This Appendix contains additional provisions for application in Queensland as follows:

HEALTH AND AMENITY

QLD1- * * * * *

Qld 1
Amdt No. 3

This clause has been deliberately left blank.

Amdt 3

QLD2 - FLASHING OF NARROW SPACES AND VERMIN CONTROL

QLD2.1 PERFORMANCE PROVISIONS

Objective

The *Objective* is to safeguard people from injury and illness resulting from the creation of hazardous spaces between buildings.

Functional Statement

The space between buildings must not allow hazardous conditions to arise due to vermin and weather.

Performance Requirement

Spaces between buildings on adjoining sites which are narrower than 600 mm must be sealed off and flashed over to prevent the entrance of weather and vermin.

QLD2.2 ACCEPTABLE CONSTRUCTION PRACTICE

Qld 2.2.1 Control of vermin

Buildings must be constructed to prevent the entry of vermin in accordance with Part 17 (Vermin Control) of the Health Regulation 1996.

SOUTH AUSTRALIA ADDITIONS

Application of South Australian variations

This Appendix contains additional provisions for application in South Australia as follows:

SA ACCEPTABLE CONSTRUCTION MANUAL

SA 1 Application

Compliance with the *Deemed-to-Satisfy Provisions* of the South Australian Housing Code 1996 for Class 1a and Class 10a buildings satisfies the *Performance Requirements* in Section 2 as modified by any variations and additions for South Australia.

SA 2 - * * * * *

SA 2
Amdt No. 3

This clause has been deliberately left blank.

HEALTH AND AMENITY

SA 3 - Wet areas

SA 3.1 PERFORMANCE PROVISIONS

Objective

SA 3.1
Amdt No. 3

As per Section 2 *Objectives* for *wet areas*.

Functional Statement

As per Section 2 *Functional Statement* for *wet areas*.

Performance Requirement

Floors in bathrooms, or rooms containing a shower or a sanitary fixture must be installed in a manner that will prevent accumulation of water on the surface which could create unhealthy or hazardous conditions.

SAFE MOVEMENT AND ACCESS

SA 4 SWIMMING POOL SAFETY

Limitation:

SA 4 only applies to a *swimming pool* associated with a Class 1 building with a depth of water more than 300 mm.

SA 4.1 PERFORMANCE PROVISIONS

Objective

As per Section 2 *Objective 2.5.3*.

Functional Statement

A *swimming pool* must not allow a young child to be entrapped or injured due to suction by pump intakes.

Performance Requirement

Pump intakes to *swimming pools* must have such dimensions and safety protection measures so as to prevent injury to a young child due to entrapment by suction.

SA 4.2 ACCEPTABLE CONSTRUCTION PRACTICE

SA 4.2.1 Application

Compliance with the acceptable construction practice provisions of SA 4.2.2 for swimming pool pump intakes satisfies *Performance Requirement SA 4.1*.

SA 4.2.2 Pump Intakes

A swimming pool water recirculation and filtration system must comply with AS 1926.3 and have at least two pump intakes not less than 800 mm apart.

SA 5 ACCESS FOR PEOPLE WITH DISABILITIES

Limitation:

SA 5 applies to Class 1 buildings when a development of 20 or more sole occupancy units is undertaken on an allotment.

SA 5.1 PERFORMANCE PROVISIONS**Objective**

Provide, as far as is reasonable, people with safe equitable and dignified access to a degree necessary to-

- (a) buildings; and
- (b) the services and facilities within.

Functional Statement

A building to a degree necessary is, as far as is reasonable, to provide safe, equitable and dignified access for people to the services and facilities within.

Performance Requirement

Buildings and immediate surrounds must have appropriate features to a degree necessary to enable people with disabilities to safely and equitably-

- (a) negotiate the route from the road boundary to and within the building using a wheelchair; and
- (b) have access to spaces within the building, including facilities *required* under P2.4.3.

SA 5.2 ACCEPTABLE CONSTRUCTION PRACTICE**SA 5.2.1 Application**

Compliance with the acceptable construction practice provisions of Part SA 5.2 for access for people with disabilities satisfies *Performance Requirement* SA 5.1.

SA Part 5.2 applies to certain Class 1 buildings where access is *required* under Clause SA 5.2.2.

SA 5.2.2 Access to buildings

Whenever 20 or more sole occupancy units including Class 1 buildings are constructed on an allotment, access must be provided to and within one sole occupancy unit or 5% of the sole occupancy units, whichever is the greater.

SA 5.2.3 Parts of buildings to be accessible

- (a) Access for people with disabilities must be provided from the entrance doorway to areas normally used by the occupants. A path of travel providing *required* access must not include a stairway or other impediment which would prevent a person in a wheelchair using it.
- (b) Access, finishes and fittings must comply with the provisions of AS 1428.1.
- (c) In every Class 1 building to which access for people with disabilities is *required*, one closet pan and washbasin and one shower must be provided for use by people with disabilities.

SA 5.2.3(c)
Amdt No. 2

SA 6 - ACCESS FOR INSPECTION AND MAINTENANCE**SA 6.1 PERFORMANCE PROVISIONS****Objective**

The *Objective* is to safeguard people from injury and illness resulting from the creation of hazardous spaces between buildings.

Functional Statement

The space between buildings must not allow hazardous conditions to arise due to accumulation of rubbish that cannot be readily removed.

Performance Requirement

The space between buildings must be sufficient to allow access for inspection and maintenance to avoid hazardous conditions arising due to accumulation of rubbish that could-

- (a) bridge termite barriers; or
- (b) harbour vermin; or
- (c) create a fire hazard.

SA 6.2 ACCEPTABLE CONSTRUCTION PRACTICE**SA 6.2.1 Application**

Compliance with the acceptable construction provision of SA 6.2 for acceptable separation between buildings for Class 1 and 10 buildings satisfies *Performance Requirement* SA 6.1.

SA 6.2.2 Minimum separation between buildings

Unless the space between external columns is not infilled, every part of an *external wall* of a building must be not less than 600 mm from-

- (a) any boundary of the allotment, unless that wall is on or abutting that boundary; or
- (b) the *external wall* of any other building on the same allotment, unless the two buildings are abutting.

TASMANIA ADDITIONS

Application of Tasmanian variations

This Appendix contains additional provisions for application in Tasmania as follows:

FIRE SAFETY

Limitation:

Tas 1 does not apply to-

1. roof coverings or canopies of PVC, Acrylic, Polycarbonate and GRP sheeting over a balcony, verandah, carport, covered way, swimming pool, barbecue area, or similar open structure attached to a Class 1 building; or
2. Class 1 buildings on land zoned Rural (except Rural Residential) in the Municipality's or City's sealed Planning Scheme, Effective Interim Order, or Special Planning Order if situated at a distance of not less than 30 m from a wooden building or the allotment boundary or not less than 15 m from other buildings; and
3. where, in accordance with 2., a roof is covered with wood shingles or shakes, the shingles or shakes are underlaid with a material having a *Flammability index* not greater than 2.

Limitation
Amdt No. 2

Amdt 3

TAS 1 - NON-COMBUSTIBLE ROOF COVERINGS

TAS 1.1 PERFORMANCE PROVISIONS

Objective

The fire safety *Objective* is to prevent the spread of fire from air-borne embers.

Functional Statement

Protect Class 1 buildings from air-borne embers.

Performance Requirement

A Class 1 building must be protected from the spread of fire from air-borne embers from other property by the provision of a *non-combustible* roof covering.

TAS 1.2 ACCEPTABLE CONSTRUCTION PRACTICE

Tas 1.2.1 Non-combustible roofing

A roof covered with any of the following materials satisfies the *Performance Requirements* of Tas 1.1.

- (a) Metal sheeting or tiles.
- (b) Slates.
- (c) Terracotta or cement roofing tiles.
- (d) Fibre cement sheeting or shingles
- (e) Asphalt shingles except on buildings with rise in storeys exceeding 2.
- (f) Built-up roofing covered with *non-combustible* material.
- (g) Concrete, granolithic, terrazzo, cement mortar, or other similar *non-combustible* materials.

HEALTH AND AMENITY

TAS2- SWIMMING POOL WATER RETICULATION AND FILTRATION

Limitation

Tas 2 does not apply to a *swimming pool* associated with a Class 1 building if the depth of water is less than 300 mm and the volume of the pool does not exceed 15 m³.

TAS 2.1 PERFORMANCE PROVISIONS

Objective

The *Objective* is to safeguard people from illness or injury arising from the use of a *swimming pool*.

Functional Statement

Swimming pools must provide for the health and safety of swimmers and others.

Performance Requirement

Swimming pools must be provided with an adequate water recirculation, disinfection and filtration system which is suitable and safe to use.

TAS 2.2 ACCEPTABLE CONSTRUCTION PRACTICE

Tas 2.2.1 Application

Compliance with the provisions of Tas 2.2 for a *swimming pool* associated with a Class 1 building with a depth of water more than 300 mm and volume exceeding 15 m³ satisfies *Performance Requirement* Tas 2.1.

Tas 2.2.2 Water recirculation and filtration system

A water recirculation, disinfection and filtration system in a *swimming pool* must provide for -

- (a) the inlet and outlet openings for the purpose of water recirculation to be so located that water movement is continuous from inlet to outlet; and
- (b) the inlet and outlet openings, and skimmer boxes where provided, to comply with AS 1926.3; and
- (c) the recirculation of water to be so designed that the pool contents are recirculated not less than once-
 - (i) in 6 hours for an outdoor *swimming pool*; or
 - (ii) in 4 hours for an indoor *swimming pool*; and
- (d) the water filtration rates to not exceed 12 250 L/m² of sand filter bed per hour, or an equivalent rate in other filter media.

VICTORIA ADDITIONS

Application of Victorian variations

This Appendix contains additional provisions for application in Victoria as follows:

HEALTH AND AMENITY

VIC1 THERMAL INSULATION

Limitation:

VIC 1 applies to Class 1 buildings only.

VIC1.1 PERFORMANCE PROVISIONS

Objective

The *Objective* is to prevent undue loss of energy from a residential building.

Functional Statement

A residential building is to be designed to achieve conservation of energy used for internal heating or cooling.

Performance Requirement

A residential building must have a reasonable level of thermal insulation to conserve energy used for internal heating and cooling.

VIC1.2 ACCEPTABLE CONSTRUCTION PRACTICE

Vic 1.2.0 Definitions

The following definition is used in this Part:

R or **R value** means the thermal resistance of an element of the building measured in $\text{m}^2\text{K/W}$.

Vic 1.2.1 Application

Compliance with the provisions of Vic Part 1.2 for thermal insulation in Class 1 buildings satisfies *Performance Requirement* Vic 1.1.

Vic 1.2.2 Exemption

Vic 1.2.3(a) does not apply to-

- (a) concrete panels, cavity brick, earth wall construction, ashlar stone or other masonry walls which have a thickness (excluding any cavity) of not less than 180 mm if the floor of the building is concrete or masonry in direct contact with the ground; or
- (b) windows, vents and other similar openings in walls, roofs and ceilings.

Vic 1.2.3 Provision of thermal insulation

- (a) The building must-
 - (i) for the elements nominated in Vic Table 1, comply with all the *R Values* of option A or all the *R Values* of option B; or
 - (ii) achieve a House Energy Rating of at least 3 stars and at least equivalent to that which would be achieved using option A or B of Vic Table 1, as assessed by-
 - (A) a registered building practitioner accredited in the use of Energy Victoria's House Energy Rating; or
 - (B) Energy Victoria.

Vic Table 1 MINIMUM OVERALL R VALUES		
Element	Option A	Option B
Roof or ceiling	<i>R2.2</i>	<i>R2.2</i>
External wall	<i>R1.3</i>	<i>R1.7</i>
Ground Floor	<i>R1.0</i>	<i>R0.7</i>
Note: For the purposes of this Table, a wall which separates a Class 1 building from a Class 10a building is regarded as an <i>external wall</i> .		

- (b) **Deemed R Value** - An element described in Vic Table 2 is deemed to have the *R value* nominated in the Table adjacent to the description of the element.

Vic Table 2 R VALUES FOR COMMON ELEMENTS	
Description of element	R value
Roofs or ceilings	
Tiled or metal pitched roof, <i>R2.5</i> bulk insulation between ceiling joists, lined ceiling	<i>R2.4</i>

Vic Table 2 (continued)	
Description of element	R value
Metal deck roof, R2.0 bulk insulation installed between rafters, rfl as a vapour barrier, ceiling lining on underside of rafters	R2.2
Metal deck roof, R2.0 bulk insulation installed between roof battens, rfl as a vapour barrier, ceiling lining on top of exposed rafters	R2.2
Tiled roof, rfl as sarking and insulation, R2.0 bulk insulation installed between counter battens, optional rfl as a vapour barrier, ceiling lining on top of exposed rafters	R2.2
External walls	
Brick/masonry veneer with R1.5 bulk insulation between the studs, lined internally	R1.7
Brick/masonry veneer with R1.0 foam board fixed over the face of the studs, lined internally	R1.7
Brick/masonry veneer with double sided rfl fixed to external face of studs, lined internally	R1.3
Weatherboard/fibre cement cladding, R1.5 bulk insulation between studs, lined internally	R1.7
Weatherboard/fibre-cement, double sided perforated rfl dished between studs lined internally	R1.3
Cavity brick with R0.8 foam board in cavity	R1.3
150 mm concrete panel with R1.0 foam board and lined internally	R1.3
Floors	
Concrete/masonry on ground	R1.5
Timber framed floor, enclosed perimeter	R1.0
Timber framed floor, unenclosed perimeter, 20 mm foam board fixed to the underside of floor joists	R1.0
Timber framed floor unenclosed perimeter	R0.7
Note: For the purposes of this Table an enclosed perimeter may incorporate sub-floor ventilation at the rate of approximately 7300 mm ² /m.	

Amdt 3

Vic 1.2.4 Chimneys and flues

Chimneys and flues from open solid fuel-burning appliances must be provided with a damper or flap.

Vic 1.2.5 Installation of reflective foil laminate

Installation of reflective foil laminate (rfl) must comply with AS/NZS 4200.2.

SPECIAL REQUIREMENTS FOR CERTAIN BUILDINGS AND COMPONENTS

In addition to any applicable provisions of the Building Act 1993, the Building Regulations 1994 and the *Housing Provisions*, there are a number of technical building design and construction requirements of which practitioners should be aware. The following is a list of some of these:

1. **Accommodation - Residential (boarding houses, guest houses, hostels)**
 - 1.1 Approval authority: Municipal council
 - 1.2 Relevant legislation: Health Act 1958, Health (Prescribed Accommodation) Regulations 1990
2. **Alpine Resorts - approval of construction**
 - 2.1 Approval authority: Alpine Resorts Commission
 - 2.2 Relevant legislation: Alpine Resorts Act 1983
3. **Crown land - construction approval**
 - 3.1 Approval authority: Crown Land and Assets Division, Department of Natural Resources and Environment
 - 3.2 Relevant legislation: Crown Land (Reserves) Act 1978
4. **Electrical installations**
 - 4.1 Authority: Electricity supply companies
 - 4.2 Relevant legislation: Electricity Industry Act 1993, State Electricity Commission Act 1958, Electric Light and Power Act 1958, SEC Wiring Regulations 1992
 - 4.3 Design codes: SAA Wiring Rules, AS 3000/3013
5. **Fences - (dividing)**
 - 5.1 Relevant legislation: Fences Act 1968
 - 5.2 Appeal body: Magistrates' Court
6. **Fire prevention in existing buildings**
 - 6.1 Authority: Municipal council
 - 6.2 Relevant legislation: Building Act 1993, Building Regulations 1994, Health Act 1958
 - 6.3 Appeal body: Building Appeals Board (Building Act only)
7. **Gas installations**
 - 7.1 Approval authority: Gas and Fuel (Gascor)
 - 7.2 Relevant legislation: Gas industry Act 1994, Gas and Fuel Corporation (Gas Installation) Regulations 1992
 - 7.3 Design codes: Gas Installation Code AG601 1992
8. **Historic buildings**
 - 8.1 Approval authority: Executive Director under the Heritage Act 1995
 - 8.2 Relevant legislation: Heritage Act 1995
 - 8.3 Appeal body: Heritage Council
9. **Movable dwellings (in caravan parks)**
 - 9.1 Approval authority: Municipal council
 - 9.2 Relevant legislation: Caravan Parks and Movable Dwellings Act 1988; Caravan Parks and Movable Dwellings (Registration and Standards) Regulations 1993.
 - 9.3 Appeals body: Caravans Parks Committee c/o Office of Local Government, Department of Infrastructure
10. **Occupational health and safety**
 - 10.1 Approval authority: Victorian WorkCover Authority

-
- 10.2 Relevant legislation: Occupational Health and Safety Act 1985, Occupational Health and Safety (Lead Control) Regulations 1988, Occupational Health and Safety (Asbestos) Regulations 1992, Health Act 1958.
- 10.3 Design codes: Various codes of practice published by the Authority
- 11. Planning controls**
- 11.1 Approval authority: Municipal council, in some cases the Minister for Planning and Local Government
- 11.2 Relevant legislation: Planning and Environment Act 1987
- 11.3 Design codes: Planning schemes
- 11.4 Appeal body: Administrative Appeals Tribunal
- 12. Sanitary plumbing, water supply and sewerage**
- 12.1 Approval authority: Melbourne Water in metropolitan area, sewerage and water supply authorities in country areas
- 12.2 Relevant legislation: Water Industry Act 1994, Water Act 1989, MMBW Act 1958, Water Corporation Act 1992, Victoria Water Supply and Sewerage Plumbing Regulations 1994
- 12.3 Design codes: AS 3500 National Plumbing and Drainage Code 1990
- 13. Septic tank installations**
- 13.1 Approval authority: Municipal council, Environment Protection Authority (discharge > 5000 l/day)
- 13.2 Relevant legislation: Environment Protection Act 1970
- 13.3 Design codes: Septic Tanks Code of Practice 1990
- 14. Subdivision of buildings**
- 14.1 Approval authority: Municipal Council
- 14.2 Relevant legislation: Subdivision Act 1988

WESTERN AUSTRALIA ADDITIONS

Western Australia has no additions to the Housing Provisions.

INDEX ABBREVIATIONS AND SYMBOLS

Index	55,011
Abbreviations and Symbols	55,101

INDEX

(TO DEEMED-TO-SATISFY PROVISIONS)

A**Adoption of Standards and other references:** 1.1.2**Air-handling systems**, ventilation of rooms: 3.8.5**Airlocks:** 3.8.5.3
ceiling heights: 3.8.2**Alarm systems**, smoke detection and alarm systems: 3.7.2**Alpine area**, definition: 1.1.1.2
fire safety construction: 3.7.5**Alteration**, definition: 1.1.1.2**Aluminium Structures Code:** 3.11.4**Amenity and health:** Part 3.8**Application of the BCA**, general: 1.0
to a particular State or Territory: 1.1.6**Appropriate authority**, definition: 1.1.1.2**Articulated masonry**, definition: 3.2
articulation joints: 3.3.1.8**Artificial lighting:** 3.8.4.3**Automatic**, definition: 1.1.1.2**Average recurrence interval**, definition: 1.1.1.2**B****Balconies**, barriers: 3.9.2**Balustrades:** 3.9.2**Barrier**, termite: 3.1.3
handrail, balustrade: 3.9.2**Bathroom**, ceiling height: 3.8.2
walls, sound insulation: 3.8.6
waterproofing: 3.8.1**Baths**, required facilities: 3.8.3
waterproofing: 3.8.1**Bedrooms**, natural light: 3.8.4

-
- Bracing**, masonry walls: 3.3.2.1
timber frames: 3.4.3.8
- Brick ties**: 3.3.3
- Building classifications**: 1.3
- Bushfire prone areas**, construction: 3.7.4
- C**
- Ceiling heights**: 3.8.2
- Cellulose fibre reinforced cement roofing**: 3.5.1
- Certificate of Accreditation**, definition: 1.1.1.2
- Chimneys**, flues, fireplaces, heating appliances: 3.7.3
- Cladding**, roof and wall: 3.5
- Class 1 buildings**, classification: 1.3
sanitary facilities: 3.8.3
Type of fire-resisting construction required: 3.7.1
- Classification**, of buildings: 1.3
principles: 1.3.1
multiple: Type of construction: 1.3.3
- Closet pans**, sanitary facilities: 3.8.3
location, 3.8.5
- Clothes washing facilities**, 3.8.3
- Combustible**, definition: 1.1.1.2
- Common wall**, definition: 1.1.1.2
- Composite steel and concrete**, construction: 3.11
- Concrete**: 3.2.3
- Concrete roofing tiles**, installation: 3.5.1
- Concrete structures**, construction: 3.11
- Controlled fill**, definition: 3.2
- Corridor**, ceiling height: 3.8.2
- Corrosion protection**, wall ties: 3.3.3.2
steel lintels: 3.4.4
steel framing: 3.4.2.2
timber connectors: 3.4.3.2
metal roofing systems: 3.5.1.3

Cyclonic areas, location: 3.10.1

D

Damp and weatherproofing, performance provisions: 2.2

Damp-proof course: 3.3.4

Damp-proofing, floors on ground: 3.2.2

Dampness, on building site: 3.1.1
weatherproofing: 3.3.4

Dead load, structural requirements: 3.11

Design suitability: 1.2.2

Design wind speed, definition: 1.1.1.2

Designated bushfire prone area, definition: 1.1.1.2

Domestic-type heating appliances: 3.7.3

Downpipes, 3.5.2

Drainage, stormwater: 3.1.2
roofs, 3.5.2

E

Early Fire Hazard Indices: roof sarking 3.7.1
determination: 1.2.4

Earthquake areas, location: 3.10.2
construction requirements: 3.10.2

Earthquake load, structural requirements: 3.10.2 and 3.11

Earthwall construction, structural provisions: 3.3.5

Earthworks: 3.1.1

Evidence of suitability of materials, form of construction or design: 1.2.2

Excavation, vacant adjoining property: 3.1.1.2
existing buildings: 3.1.1.3
for drains: 3.1.2.2
for footings: 3.2.2.1

Exhaust ventilation, closet pan, urinal: 3.8.5
kitchen local exhaust ventilation: 3.8.5

Exit, in alpine areas: 3.7.5

- Explanatory information**, use of: 1.1.9
- External stairways**: 3.9.1
- External wall**, definition: 1.1.1.2
 fire-resistance Class 1 and 10 buildings: 3.7.1
 protection of openings: 3.7.1
- F**
- Facilities**, sanitary and other: 3.8.3
- Fencing**, swimming pools: 3.9.3
- Fibre reinforced cement**, roof sheeting, installation: 3.5.1
- Fill**, earthworks: 3.1.1.4
 under slabs: 3.2.2.2
- Finished ground level**, definition: 3.2
 surface water drainage: 3.1.2.3
- Fire and smoke**, alarms: 3.7.2
- Fire safety**, performance provisions: 2.3
- Fire separation**: 3.7.1
- Fireplaces**, masonry construction: 3.3.1
 footings, 3.2.5
 heating appliances, chimneys and flues: 3.7.3
- Fire-resistance**, separating walls: 3.7.1
 external walls: 3.7.1
 masonry-veneer walls: 3.7.1
 roofs: 3.7.1
 of building elements: 1.2.3
- Fire-Resistance Level**, definition: 1.1.1.2
 external walls: 3.7.1
- Fire-resisting**, definition: 1.1.1.2
- Fire-resisting construction**, definition: 1.1.1
 acceptable walls, 3.7.1
- Fire-source feature**, definition: 1.1.1.2
 diagram 2.3
- Fire windows**, protection of openings: C3.4
 construction: Spec C3.4

-
- Flammability Index**, definition: 1.1.1.2
sarking type materials: 3.7.1
- Flashings**: 3.3.4
sheet metal roofs: 3.5.1.3
openings in wall cladding: 3.5.3.6
- Floor area**, definition: 1.1.1.2
- Floors**, on ground, damp-proofing: 3.2.2
timber, sub-floor ventilation: 3.4.1
- Flues**, chimneys, fireplaces, heating appliances: 3.7.3
- Footings**: 3.2
construction: 3.2.5
- Foundation**, definition: 1.1.1.2
allowable bearing pressure: 3.2.2.3
- Framing**, steel: 3.4.2
timber: 3.4.3
- G**
- Garage**, private, definition: 1.1.1.2
weatherproofing, masonry: 3.3.4
- Glass**, installation: 3.6
- GRP sheeting**, roof construction: 3.5.1
- Gutters**, roof drainage: 3.5.2
- H**
- Habitable room**, definition: 1.1.1.2
ceiling height: 3.8.2
natural light: 3.8.4
walls, sound insulation: 3.8.6
- Handrails**, construction: 3.9.2
- Health and amenity**: Part 3.8
performance provisions: 2.4
- Hearth**, construction of fireplaces: 3.7.3
- Heating appliances**, fireplaces, chimneys and flues: 3.7.3
- Height of rooms**: 3.8.2
- High wind area**, definition: 1.1.1.2
-

Housing Provisions, definition: 1.1.1.2

I

Illuminance, definition: 1.1.1.2

Impact sound, acceptable construction, 3.8.6

Insulation, fire-resistance level, definition: 1.1.1.2

Insulation, sound: Part 3.8.6

Integrity, fire-resistance level, definition: 1.1.1.2

Internal wall, definition: 1.1.1.2

Interpretation, of diagrams: 1.1.8

J

K

Kitchen, ceiling height: 3.8.2

local exhaust ventilation: 3.8.5

sinks, sanitary and other facilities: 3.8.3

walls, sound insulation: 3.8.6

L

Ladders: access to storerooms, 3.9.1

Land, drainage: 3.1.1

Language: 1.1.7

Landings, balustrades: 3.9.2

dimensions and construction: 3.9.2

stairways: 3.9.1

Latches, door, operation for swimming pool access: 3.9.3

Lateral support, definition: 3.3

Laundry, ceiling height: 3.8.2

walls, sound insulation: 3.8.6

waterproofing: 3.8.1

Light, artificial: 3.8.4.3

natural: 3.8.4.2

Lightweight construction, definition: 1.1.1.2

Lintels, masonry: 3.3.3, 3.3.2.2

timber: 3.4.3.5

structural steel beams 3.4.4

Live load, structural requirements: 3.11

Loadbearing, definition: 1.1.1.2

Loadbearing wall, definition: 3.2

Loads, structural requirements: 3.11

M

Maintenance of smoke alarms: 3.7.2

Masonry, 3.3

units: 3.3.1.5

accessories: 3.3.3

Masonry-veneer walls, fire-resistance: 3.7.1

external walls: 3.3.1.2

Materials, structural requirements: 3.11

suitability: 1.2.1

Mechanical ventilation, air locks: 3.8.5

kitchen local exhaust: 3.8.5

rooms: 3.8.5

Metal roofing, installation: 3.5.2

Moisture barriers, floor on ground: 3.2.2.6

Mortar, mixes: 3.3.1.6

joints: 3.3.1.7

Multiple classifications: 1.3.3

N

Natural light: 3.8.4

borrowed: 3.8.4

Natural ventilation: 3.8.5

borrowed: 3.8.5

Noise transmission: see 'sound transmission'

Non-combustible, definition: 1.1.1.2

materials: 3.7.1

O

Oil-fired appliances, 3.7.3

Open fireplaces, construction: 3.7.3

-
- Openings**, in external walls 3.7.1
- Other property**, definition: 1.1.1.2
- Outdoor air**, definition: 1.1.1.2
- Outfall**, drainage system, definition: 1.1.1.2
- P**
- Particleboard structural flooring**, installation: 3.4.3.4
- Passageway**, ceiling height: 3.8.2
- Piling**, construction: 3.2.1
- Pipes**, soil and waste, sound insulation: 3.8.6
- Pools**, swimming: 3.9.3
- Principles of classification**: 1.3
- Private garage**, definition: 1.1.1.2
- Professional engineer**, definition: 1.1.1.2
- Protection of openings**: in Class 1 buildings, 3.7.1
- PVC sheeting**, roof construction: 3.5.1
roof lights: 3.7.1
- Q**
- R**
- Referenced Standards**: 1.4
- Registered Testing Authority**, definition: 1.1.1.2
- Reinforcing**, concrete: 3.2.3
- Reinforced masonry**: 3.3.2
- Required**, definition: 1.1.1.2
- Risers and treads**, dimensions: 3.9.1
- Roof**, construction - frame: 3.4
coverings: 3.5.1 and 3.5.2
fire-resistance: 3.7.1
sarking: 3.7.1
- Roof lights**: 3.7.1
- Roof tiles**: 3.5.1.2

Room height: 3.8.2

S

Safe movement and access, performance provisions: 2.5

Safety fencing, swimming pools: 3.9.3

Sanitary compartment, definition: 1.1.1.2
waterproofing: 3.8.1

Sanitary and other facilities: 3.8.3

Sarking, roof, fire proofing: 3.7.1
installation: 3.5.1

Sarking-type material, definition: 1.1.1.2
Early Fire Hazard Indices: 3.7.1

Self closing, door or window, definition: 1.1.1.2

Separating wall, definition: 1.1.1.2
fire resistance level: 3.7.1

Separation, by separating walls: 3.7.1

Shower enclosures, waterproofing: 3.8.1

Showers, requirements: 3.8.3

Site, definition: 1.1.1.2
dampness: 3.1.1
earthworks: 3.1.1
drainage: 3.1.2
classification: 3.2.4

Sitework, definition: 1.1.1.2

Slabs: 3.2
construction: 3.2.5

Smoke alarms: 3.7.2

Smoke-Developed Index, definition: 1.1.1.2

Snow, areas, fire safety construction: 3.7.5
load, structural requirements: 3.11

Soil and waste pipes, sound insulation: 3.8.6

Soil treatment, against termites: 3.1.3

Solid-fuel burning appliances, domestic-type: 3.7.3

-
- Sound insulation**, impact, test of equivalence: 3.8.6
walls between buildings: 3.8.6
waste and soil pipes: 3.8.6.4
- Sound transmission and insulation**: 3.8.6
- Sound Transmission Class**, interpretation: 3.8.6
- Spread-of Flame Index**, definition: 1.1.1.2
- Stair**, dimensions, treads and risers: 3.9.1
- Stairway**, landings, construction: 3.9.1
- Standard Fire Test**, definition: 1.1.1.2
- Standards**, adoption: 1.1.2, 1.1.3, 1.4
- STC**, ratings for building elements: 3.8.6
- Steel**, construction: 3.4.2 and 3.4.4
floor framing: 3.4.2.3
wall framing: 3.4.2.4
roof framing: 3.4.2.5
- Stormwater drainage**: 3.1.2, 3.5.2
- Structural adequacy**, Fire-Resistance Level, definition: 1.1.1.2
- Structural member**, definition: 1.1.1.2
- Structural Provisions**: 3.11
- Structural steel members**, 3.4.4
- Structure**, performance provisions: 2.1
- Structures**, trafficable, alpine areas: 3.7.5
- Sub-floor ventilation**: 3.4.1
- Subsoil drainage**: 3.1.2
- Suitability of materials**, construction or design: 1.2.1
- Surface water**, definition: 1.1.1.2
drainage: 3.1.2.3
- Swimming pool**, definition: 1.1.1.2
requirements: 3.9.3
- T**
- Termite shields**, damp-proof course: 3.3.4
- Termite risk management**: 3.1.3
-

-
- Terracotta**, roof tiles, installation: 3.5.1
weatherproofing: 3.5.4
- Tilt-up construction**, external walls - concrete construction: 3.11
- Timber**, construction: 3.4.3
floors, sub-floor ventilation: 3.4.1
floor framing: 3.4.3.3
flooring: 3.4.3.4
wall framing: 3.4.3.5
roof framing: 3.4.3.6
- Treads and risers**, dimensions: 3.9.1
- Truss connections**, to masonry: 3.3.2.2
- U**
- Unreinforced masonry**: 3.3.1
- V**
- Vapour barriers**, floor on ground: 3.2.2
- Ventilation**, exhaust: 3.8.5
natural: 3.8.5
of rooms: 3.8.5
sub-floor: 3.4.1, 3.3.1.9
- W**
- Wall cladding**: 3.5.3
- Wall ties**: 3.3.3
- Walls**, between units, sound insulation: 3.8.6
- Washbasins**, requirements: 3.8.3
- Waste and soil pipes**, sound insulation: 3.8.6
- Water closets**, restricted location: 3.8.5
waterproofing: 3.8.1
- Water resistant materials**, wet areas in buildings: 3.8.1
- Weatherproofing**: 3.3.4
dampness slab-on-ground: 3.2.3
of roofs and walls: 3.5
- Weep holes**, protection of openings, in bushfire areas: 3.7.4
- Wet areas**, in buildings, waterproofing: 3.8.1
- Wind load**, structural requirements: 3.11
-

Window, definition: 1.1.1.2
methods of protection of openings: 3.7.1
natural light: 3.8.4

X

Y

Z

ABBREVIATIONS AND SYMBOLS

Abbreviations and Symbols used in the *Housing Provisions* include:

ABBREVIATIONS

ABCB	Australian Building Codes Board
AISC	Australian Institute of Steel Construction
ALGA	Australian Local Government Association
AS	Australian Standard
ASTM	American Society for Testing and Materials
BCA	Building Code of Australia
BCC	Building Codes Committee
CSIRO	Commonwealth Scientific and Industrial Research Organisation
DBC&E	CSIRO Division of Building, Construction and Engineering
FRL	Fire Resistance Level
GRP	glass fibre reinforced polyester
ISO	International Organisation for Standardisation
NATA	National Association of Testing Authorities
NBTC	CSIRO National Building Technology Centre
PVC	polyvinyl chloride
SSL	Scientific Services Laboratory
STC	Sound Transmission Class
UPVC	unplasticised polyvinyl chloride

SYMBOLS AND SI UNITS

°C -degree(s) Celsius	m - metre(s)
K - kelvin(s)	m ² - square metre(s)
kg - kilogram(s)	m ³ - cubic metre(s)
kg/m - kilogram(s) per metre	m/s - metre(s) per second
kg/m ² - kilogram(s) per square metre	m ³ /s - cubic metre(s) per second
kg/m ³ - kilogram(s) per cubic metre	mm - millimetre(s)
km - kilometre	mm ² - square millimetre(s)
kPa - kilopascal(s)	um - micrometer
kW/m ² - kilowatt(s) per square metre	MW - megawatt(s)
L - litre(s)	N - newton(s)
L/s - litre(s) per second	MPa - megapascal(s)
L/s.m ² - litre(s) per second square metre	> - greater than
lx - lux	< - less than
∅ - diameter	≤ - equal to or less than
F - in relation to steel members means steel fabric	≥ - equal to or more than

HISTORY OF AMENDMENTS

HISTORY CONTENTS

	Page
History of amendments	57,021
1.0 Adoption of BCA 96	
1.1 Amendment No. 1	
1.2 Amendment No. 2	
1.3 Amendment No. 3	

HISTORY OF AMENDMENTS

1.0 Adoption of BCA96

The 1996 edition of the BCA was adopted by the Commonwealth, States and Territories as set out in Table 1.0.

Table 1.0
Amdt No. 3

Table 1.0 History of adoption of BCA96	
Administration	Adoption Date
Commonwealth	1 July 1997
Australian Capital Territory	1 July 1997
New South Wales	1 July 1997
Northern Territory	7 January 1998
Queensland	1 July 1997
South Australia	1 January 1998
Tasmania	1 July 1997
Victoria	1 August 1997
Western Australia	1 July 1997

Amdt 3

1.1 Amendment No. 1

(a) Amendment No. 1 of the 1996 edition of the BCA was adopted by the Commonwealth, States and Territories as set out in Table 1.1.

Table 1.1
Amdt No. 3

Table 1.1 History of adoption of Amendment No. 1 of BCA96	
Administration	Adoption Date
Commonwealth	1 July 1997
Australian Capital Territory	1 July 1997
New South Wales	1 July 1997
Northern Territory	7 January 1998
Queensland	1 July 1997
South Australia	1 January 1998
Tasmania	1 July 1997
Victoria	1 August 1997
Western Australia	1 July 1997

- (b) The purpose of Amendment No. 1 is to—
 - (i) include typographical changes including spelling, punctuation, cross references and layout; and
 - (ii) include reference to a *Certificate of Conformity* issued by the ABCB in A2.2; and
 - (iii) change the reference to the Standards Mark Certificate to refer to JAS-ANZ in A2.2; and
 - (iv) update references to Standards.

Note: The revisions contained in Amendment No. 1 to the *Housing Provisions* have not been marked in the text.

1.2 Amendment No. 2

- (a) Amendment No. 2 of the 1996 edition of the BCA was adopted by the Commonwealth, States and Territories as set out in Table 1.2.

Table 1.2
Amdt No. 3

Table 1.2 History of adoption of Amendment No. 2 of BCA96	
Administration	Adoption Date
Commonwealth	1 January 1998
Australian Capital Territory	1 January 1998
New South Wales	27 February 1998
Northern Territory	7 January 1998
Queensland	1 January 1998
South Australia	1 January 1998
Tasmania	1 January 1998
Victoria	1 January 1998
Western Australia	1 January 1998

- (b) The purpose of Amendment No. 2 is to –
 - (i) include typographical changes including spelling, punctuation, cross references and layout; and
 - (ii) update references to Standards; and
 - (iii) include minor technical changes.

1.3 Amendment No. 31.3
Amdt No. 3

- (a) Amendment No. 3 of the 1996 edition of the BCA was adopted by the Commonwealth, States and Territories as set out in Table 1.3.

Table 1.3 History of adoption of Amendment No. 3 of BCA96	
Administration	Adoption Date
Commonwealth	1 July 1998
Australian Capital Territory	1 July 1998
New South Wales	To be advised
Northern Territory	7 July 1998
Queensland	1 July 1998
South Australia	To be advised
Tasmania	1 July 1998
Victoria	1 July 1998
Western Australia	1 July 1998

- (b) The purpose of Amendment No. 3 is to –
- (i) incorporate the outcomes of the 1997 ABCB Variations Conference; and
 - (ii) update references to Standards; and
 - (iii) include minor technical changes.