

SUPERSEDED

Building Code of Australia

SUPERSEDED

B

C

A



ABC

Australian
Building
Codes
Board

CONTENTS AND FEATURES • INTRODUCTION

GENERAL TABLE OF CONTENTS

	Page
CONTENTS AND FEATURES	
Introduction	101
1 The Building Code of Australia	
2 The Australian Building Codes Board	
3 The BCA - Content	
4 Legislative arrangements	
5 Documentation of decisions	
6 Structure	
7 Further development of the BCA	
8 Comments	
SECTION 1 - GENERAL	
1.0 Application	2,015
1.0.1 Adoption	
1.0.2 BCA Volumes	
1.0.3 BCA Structure	
1.0.4 Compliance with the BCA	
1.0.5 Meeting the Performance Requirements	
1.0.6 Objectives and Functional Statements	
1.0.7 Deemed-to-Satisfy Provisions	
1.0.8 Alternative Solutions	
1.0.9 Assessment Methods	
1.1 Interpretation	2,021
1.1.1 Definitions	
1.1.2 Adoption of referenced documents	
1.1.3 Context of reference	
1.1.4 Differences between referenced documents and the Housing Provisions	
1.1.5 Compliance with all Sections of the Housing Provisions	
1.1.6 Application of the Housing Provisions to a particular State or Territory	
1.1.7 Language	
1.1.8 Interpretation of diagrams	
1.1.9 Explanatory information	
	Continued

Continued	Page
1.2 Acceptance of design and construction	2,201
1.2.1 Suitability of materials	
1.2.2 Evidence of suitability	
1.2.3 Fire resistance of building elements	
1.2.4 Early fire hazard indices	
1.3 Classification	2,401
1.3.1 Principles of classification	
1.3.2 Classification	
1.3.3 Multiple classifications	
1.4 Standards adopted by reference	2,601
1.4.1 Schedule of referenced documents	
 SECTION 2 - PERFORMANCE PROVISIONS	
2.0 Application	3,021
2.1 Structure	3,031
P2.1 Structural stability and resistance to actions	
2.2 Damp and weatherproofing	3,201
P2.2.1 Surface water	
P2.2.2 Weatherproofing	
P2.2.3 Dampness	
P2.2.4 Drainage from swimming pools	
2.3 Fire safety	3,401
P2.3.1 Protection from the spread of fire	
P2.3.2 Fire detection and early warning	
P2.3.3 Heating appliances	
P2.3.4 Bushfire areas	
P2.3.5 Alpine areas	
2.4 Health and amenity	3,601
P2.4.1 Wet areas	
P2.4.2 Room heights	
P2.4.3 Facilities	
P2.4.4 Light	
P2.4.5 Ventilation	
P2.4.6 Sound insulation	
	Continued

Amdt 11

Continued	Page
2.5 Safe movement and access	3,801
P2.5.1 Stairways and ramps	
P2.5.2 Barriers	
P2.5.3 Swimming pools access	
SECTION 3 - ACCEPTABLE CONSTRUCTION	
How to use	4,031
Introduction	
The scope of these provisions	
Suitability of Alternative Solutions	
The use of maps	
Consultation with appropriate authorities	
Layout of Parts 3.1 - 3.11	
How to use the requirements of each Part	
3.1 Site preparation	
3.1.1 Earthworks	5,021
3.1.1.0 Application	
3.1.1.1 Earthworks	
3.1.1.2 Excavation adjacent to vacant adjoining property	
3.1.1.3 Excavation adjacent to existing buildings	
3.1.1.4 Fill	
3.1.2 Drainage	5,201
3.1.2.0 Acceptable construction manual	
3.1.2.1 Application	
3.1.2.2 Drainage requirements	
3.1.2.3 Surface water drainage	
3.1.2.4 Subsoil drainage	
3.1.2.5 Stormwater drainage	
3.1.3 Termite risk management	5,501
3.1 Definitions	
3.1.3 Application of this Part	
3.1.3.0 Acceptable construction manual	
3.1.3.1 Application	
3.1.3.2 Installation of termite barriers	
3.1.3.3 Barriers for concrete slab-on-ground	
3.1.3.4 Barriers for suspended floors	
3.1.3.5 Attachments to buildings	
	Continued

Amdt 11

[Next page is 21]

Continued		Page
3.2	Footings and slabs	7,021
3.2	Definitions	
3.2.0	Acceptable construction manuals	
3.2.1	Application	
3.2.2	Preparation	7,201
3.2.2.1	Excavation for footings	
3.2.2.2	Filling under concrete slabs	
3.2.2.3	Foundations for footings and slabs	
3.2.2.4	Slab edge support on sloping sites	
3.2.2.5	Stepped footings	
3.2.2.6	Vapour barriers	
3.2.2.7	Edge rebates	
3.2.3	Concrete and reinforcing	7,401
3.2.3.1	Concrete	
3.2.3.2	Steel reinforcement	
3.2.4	Site classification	7,601
3.2.4.1	Site classification	
3.2.5	Footing and slab construction	7,801
3.2.5.1	Footing and slab construction	
3.2.5.2	Footings and slabs to extensions to existing buildings	
3.2.5.3	Shrinkage control	
3.2.5.4	Minimum edge beam dimensions	
3.2.5.5	Footings for fireplaces on Class A and S sites	
3.2.5.6	Stump footing details	
3.3	Masonry	
3.3	Definitions	9,012
3.3.1	Unreinforced masonry	9,021
3.3.1.0	Acceptable construction manual	
3.3.1.1	Application	
3.3.1.2	External walls	
3.3.1.3	Internal walls	
3.3.1.4	Isolated piers	
3.3.1.5	Masonry units	
3.3.1.6	Mortar mixes	
		Continued

Amdt 11

Continued	Page
3.3.1.7 Mortar joints	
3.3.1.8 Vertical articulation joints	
3.3.1.9 Sub-floor ventilation	
3.3.1.10 Shrinkage allowance for timber framing	
3.3.2 Reinforced masonry	9,301
3.3.2.0 Acceptable construction manual	
3.3.2.1 Application	
3.3.2.2 External wall construction	
3.3.3 Masonry accessories	9,601
3.3.3.0 Acceptable construction manual	
3.3.3.1 Application	
3.3.3.2 Wall ties	
3.3.3.3 Fixing straps and tie down systems	
3.3.3.4 Lintels	
3.3.4 Weatherproofing	9,801
3.3.4 Application of this Part	
3.3.4.0 Acceptable construction manual	
3.3.4.1 Application	
3.3.4.2 Width of cavity	
3.3.4.3 Cavity ventilation and drainage	
3.3.4.4 Damp-proof courses - materials	
3.3.4.5 Damp-proof courses - installation	
3.3.4.6 Flashings	
3.3.4.7 Location of flashings	
3.3.4.8 Flashings at the base of cavity walls	
3.3.4.9 Sill and head flashing	
3.3.4.10 Flashings at a roof abutting a wall	
3.3.4.11 Chimney flashings	
3.3.4.12 Weatherproofing for single skin masonry walls	
3.3.5 Earthwall construction	10,101
3.3.5 Definitions	
3.3.5.0 Acceptable construction manual	
3.3.5.1 Application	
3.3.5.2 General construction	
3.3.5.3 Minimum thickness of walls	
3.3.5.4 Weatherproofing	
	Continued

Continued	Page
3.4 Framing	
3.4.0 Explanation of terms	11,051
3.4.1 Sub-floor ventilation	11,101
3.4.1.1 Application	
3.4.1.2 Sub-floor ventilation	
3.4.2 Steel framing	11,301
3.4.2.0 Acceptable construction manuals	
3.4.2.1 Application	
3.4.2.2 General	
3.4.2.3 Steel floor framing	
3.4.2.4 * * *	
3.4.2.5 * * *	
3.4.2.6 Installation of services	
3.4.3 Timber framing	11,601
3.4.3.0 Acceptable construction manuals	
3.4.3.1 * * *	
3.4.3.2 * * *	
3.4.3.3 * * *	
3.4.3.4 * * *	
3.4.3.5 * * *	
3.4.3.6 * * *	
3.4.3.7 * * *	
3.4.3.8 * * *	
3.4.4 Structural steel members	12,201
3.4.4 Explanation of terms	
3.4.4.0 Acceptable construction manuals	
3.4.4.1 Application	
3.4.4.2 Structural steel members	
3.4.4.3 Columns	
3.4.4.4 Corrosion protection	
3.5 Roof and wall cladding	
3.5.1 Roof cladding	13,021
3.5.1.0 Acceptable construction manuals	
3.5.1.1 Application	
3.5.1.2 Roof tiling	
3.5.1.3 Metal sheet roofing	
	Continued

Amdt 11

Continued		Page
3.5.2	Gutters and downpipes	13,301
3.5.2.0	Acceptable construction manual	
3.5.2.1	Application	
3.5.2.2	Materials	
3.5.2.3	Selection of guttering	
3.5.2.4	Installation of gutters	
3.5.2.5	Downpipes - size and installation	
3.5.3	Wall cladding	13,501
3.5.3.1	Application	
3.5.3.2	Timber weatherboard cladding	
3.5.3.3	Fibre cement planks and weatherboard cladding	
3.5.3.4	Sheet wall cladding	
3.5.3.5	Eaves and soffit linings	
3.5.3.6	Flashings to wall openings	
3.6	Glazing	15,021
3.6	Definitions	
3.6.0	Acceptable construction manual	
3.6.1	Application	
3.6.2	Glazing sizes and installation	
3.6.3	Perimeter framed glazing	
3.6.4	Human impact safety requirements	
3.6.5	Doors	
3.6.6	Side panels	
3.6.7	Full height framed glazed panels	
3.6.8	Glazed panels, other than doors or side panels, on the perimeter of rooms	
3.6.9	Shower doors, shower screens and bath enclosures	
3.7	Fire safety	
3.7.1	Fire separation	17,021
3.7.1.1	Application	
3.7.1.2	General concession - non combustible materials	
3.7.1.3	External walls of Class 1 buildings	
3.7.1.4	Measurement of distances	
3.7.1.5	Construction of external walls	
3.7.1.6	Class 10a buildings	
3.7.1.7	Allowable encroachments	
3.7.1.8	Separating walls	
		Continued

Continued		Page
3.7.1.9	Sarking-type materials	
3.7.1.10	Roof lights	
3.7.2	Smoke alarms	17,301
3.7.2.1	Application	
3.7.2.2	Requirements for smoke alarms	
3.7.2.3	Location - Class 1a buildings	
3.7.2.4	Location - Class 1b buildings	
3.7.2.5	Lighting to assist evacuation - Class 1b buildings	
	Explanatory information - Smoke alarms	
3.7.3	Heating appliances	17,501
3.7.3.0	Acceptable construction manuals	
3.7.3.1	Application	
3.7.3.2	Open fireplace construction	
3.7.3.3	Chimney construction	
3.7.3.4	Installation of insert fireplaces and flues	
3.7.3.5	Installation of free standing heating appliances	
3.7.4	Bushfire areas	17,701
3.7.4.0	Acceptable construction manuals	
3.7.4.1	Application	
3.7.4.2	Categories of bushfire attack	
3.7.4.3	Construction requirements	
3.7.5	Alpine areas	17,901
3.7.5.1	Application	
3.7.5.2	External doorways	
3.7.5.3	External ramps	
3.7.5.4	Discharge of external doorways providing a means of egress	
3.7.5.5	External trafficable structures	
3.8	Health and amenity	
3.8.1	Wet areas	19,021
3.8.1	Definitions	
3.8.1.0	Acceptable construction manual	
3.8.1.1	Application	
3.8.1.2	Wet areas	
3.8.1.3	Materials - general	
3.8.1.4	Protection of shower floors in wet areas	
		Continued

Amdt 11

Continued	Page
3.8.1.5 Protection of walls in wet areas	
3.8.1.6 Sealing of wall and floor junctions and joints	
3.8.2 Room heights	19,301
3.8.2.1 Application	
3.8.2.2 Ceiling heights	
3.8.3 Facilities	19,501
3.8.3.1 Application	
3.8.3.2 Required facilities	
3.8.3.3 Construction of sanitary compartments	
3.8.4 Light	19,701
3.8.4.1 Application	
3.8.4.2 Natural lighting	
3.8.4.3 Artificial lighting	
3.8.5 Ventilation	19,901
3.8.5.0 Acceptable construction manual	
3.8.5.1 Application	
3.8.5.2 Ventilation requirements	
3.8.5.3 Location of sanitary compartments	
3.8.6 Sound insulation	20,101
3.8.6.1 Application	
3.8.6.2 Sound insulation requirements	
3.8.6.3 General installation requirements for walls	
3.8.6.4 Soil and waste pipes	
3.9 Safe movement and access	
3.9.1 Stair construction	21,021
3.9.1 Definitions	
3.9.1.1 Application	
3.9.1.2 General requirements	
3.9.1.3 Stair construction	
3.9.1.4 Riser and going dimensions	
3.9.1.5 * * * * *	
3.9.2 Balustrades	21,201
3.9.2.1 Application	
3.9.2.2 When balustrades or other barriers are required	
3.9.2.3 Balustrade or other barrier construction	
	Continued

Amdt 11

[Next page is 101]

Continued	Page
3.9.3 Swimming pool access	21,401
3.9.3.0 Acceptable construction manual	
3.9.3.1 Application	
3.9.3.2 Safety fencing location	
3.9.3.3 Safety fencing construction	
3.9.3.4 Gates and fittings	
3.10 Additional construction requirements	
3.10.1 High wind areas	23,021
3.10.1.0 Acceptable construction manuals	
3.10.2 Earthquake areas	23,201
3.10.2 Definitions	
3.10.2.0 Acceptable construction manuals	
3.10.2.1 Application	
3.10.2.2 Construction requirements	
3.10.2.3 Construction for areas with an acceleration coefficient of 0.12 or more but less than 0.15	
3.10.2.4 Construction for areas with an acceleration coefficient of 0.15 or more	
3.11 Structural design manuals	
3.11 Acceptable construction manuals	25,021
3.11.1 Application	
3.11.2 Acceptable structural design manuals	
3.11.3 Loading requirements	
3.11.4 Structural design manuals	
APPENDIX A - State and Territory Additions	50,001
INDEX • ABBREVIATIONS AND SYMBOLS	55,001
HISTORY OF AMENDMENTS	57,001
FILING RECORD	

Amdt 11

INTRODUCTION

THE BUILDING CODE OF AUSTRALIA

The Building Code of Australia (BCA) is produced and maintained by the Australian Building Codes Board (ABCB) on behalf of the Commonwealth Government and each State and Territory Government.

The BCA is a uniform set of technical provisions for the design and construction of buildings and other structures throughout Australia. It allows for variations in climate and geological or geographic conditions.

THE AUSTRALIAN BUILDING CODES BOARD

The ABCB is established by agreement between the Commonwealth Government and each State and Territory Government. It is a co-operative arrangement between the signatories, Local Government and the building industry.

It is responsible to the Planning, Housing and Local Government Ministerial Council, and has a mission to achieve nationally consistent performance-based building regulatory systems that are efficient, cost effective and meet community and industry needs.

The Board comprises-

- (a) the principal officer of each State and Territory administration responsible for building regulatory matters; and
- (b) a representative of the Commonwealth; and
- (c) a representative of the Australian Local Government Association (ALGA); and
- (d) industry representatives.

The Building Codes Committee (BCC) is the peak technical advisory body to the ABCB, with responsibility for technical matters associated with the BCA.

The BCC comprises-

- (a) the Executive Director of the ABCB; and
- (b) one nominee each of the Commonwealth, State, Territory and ALGA members of the ABCB; and
- (c) industry members appointed by the ABCB.

THE BCA - CONTENT

GOALS

The goals of the BCA are to enable the achievement and maintenance of acceptable standards of structural sufficiency, safety (including safety from fire), health and amenity for the benefit of the community now and in the future.

These goals are applied so that the BCA extends no further than is necessary in the public interest, is cost effective, easily understood, and is not needlessly onerous in its application.

1996 EDITION

The 1996 edition of the BCA is published in two volumes:

Volume One: pertains primarily to Class 2 to 9 buildings

Volume Two: pertains primarily to Class 1 and 10 buildings (houses, sheds, carports, etc)

Both volumes are drafted in a performance format to provide greater flexibility for the use of new and innovative building products, systems and designs.

A user may choose to comply with the *Deemed-to-Satisfy Provisions* or (described as acceptable construction practice in the *Housing Provisions*) or may use an *Alternative Solution* that satisfies the *Performance Requirements*.

The *Deemed-to-Satisfy Provisions* in this edition generally are the same as those contained in the 1990 edition of the BCA for Class 1 and 10 buildings, as amended and includes other changes resulting from the ongoing technical improvement program.

Note: Class 1 buildings are typically single dwelling houses (not located one above the other); Class 10 buildings include carports, sheds, fences, swimming pools etc, which may be associated with Class 1 buildings as well as Class 2-9 buildings (see Part 1.3 for further information).

STATE AND TERRITORY VARIATIONS AND ADDITIONS

Each State's and Territory's legislation adopts the BCA subject to the variation or deletion of some of its provisions, or the addition of extra provisions. In the *Housing Provisions*, these are divided into two types:

- (a) A variation to the *Housing Provisions* - these are identified following the Clause that is being varied.
- (b) Additional requirements - these are contained in Appendix A (see the tab marked "State and Territory Additions").

SCOPE OF THE HOUSING PROVISIONS

Users of the *Housing Provisions* need to be aware that the acceptable construction practices contained in this document do not cover all types of Class 1 and 10

buildings. The limitations of the acceptable construction practices are discussed in the introduction to Section 3.

DEFINITIONS

Words with special meanings are printed in italics and are defined in 1.1.1 or, if they are specific to a Part, at the start of that Part in Section 3. Defined terms which appear in figures and diagrams may not be in italics.

LEGISLATIVE ARRANGEMENTS

GENERAL

The BCA is given legal effect by building regulatory legislation in each State and Territory. This legislation consists of an Act of Parliament and subordinate legislation which empowers the regulation of certain aspects of buildings and structures, and contains the administrative provisions necessary to give effect to the legislation.

Any provision of the BCA may be overridden by, or subject to, State or Territory legislation. The BCA must therefore be read in conjunction with that legislation. Any queries on such matters should be referred to the State or Territory authority responsible for building regulatory matters.

BCA ADOPTION

The adoption of the 1996 edition of the BCA is addressed in Part 1.0 of the *Housing Provisions*.

DOCUMENTATION OF DECISIONS

Decisions made under the BCA should be fully documented and copies of all relevant documentation should be retained.

Examples of the kind of documentation which should be prepared and retained include:

- (a) Details of the *Building Solution* including all relevant plans and other supporting documentation.
- (b) In cases where an *Alternative Solution* has been proposed-
 - (i) details of the relevant *Performance Requirements*; and
 - (ii) the *Assessment Method* or methods used to establish compliance with the relevant *Performance Requirements*; and
 - (iii) details of any *Expert Judgement* relied upon including the extent to which the judgement was relied upon and the qualifications and experience of the expert; and

[End of tab division]

- (iv) details of any tests or calculations used to determine compliance with the relevant *Performance Requirements*; and
- (v) details of any Standards or other information which were relied upon.

STRUCTURE

The BCA has been structured as set out in 1.0.3 and shown in Figure 1.0.3. It is the ABCB's intent that the *Objectives* and *Functional Statements* be used as an aid to the interpretation of the BCA and not for determining compliance with the BCA.

FURTHER DEVELOPMENT

Regular amendments are planned to the BCA to improve clarity of provisions, upgrade referenced documents and to reflect the results of research and improved technology.

The ABCB's intention is that the performance provisions of the BCA will be progressively developed. Later stages will therefore include reviewed *Objectives*, *Functional Statements* and *Performance Requirements*.

COMMENTS

Comments in writing on any matter concerning the text, presentation or further development of the BCA are invited from building and other authorities, industry organisations, professional operatives and the public generally. These comments should be addressed to:

Executive Director
Australian Building Codes Board
GPO Box 9839
CANBERRA ACT 2601

Amdt 11

SECTION **1**

Amdt 11

GENERAL REQUIREMENTS

- 1.0 Application
- 1.1 Interpretation
- 1.2 Acceptance of Design and Construction
- 1.3 Classification
- 1.4 Standards adopted by reference

SECTION 1 CONTENTS

		Page
1.0	Application	2,015
1.0.1	Adoption	
1.0.2	BCA Volumes	
1.0.3	BCA Structure	
1.0.4	Compliance with the BCA	
1.0.5	Meeting the Performance Requirements	
1.0.6	Objectives and Functional Statements	
1.0.7	Deemed-to-Satisfy Provisions	
1.0.8	Alternative Solutions	
1.0.9	Assessment Methods	
1.1	Interpretation	2,021
1.1.1	Definitions	
1.1.2	Adoption of referenced documents	
1.1.3	Context of reference	
1.1.4	Differences between referenced documents and the Housing Provisions	
1.1.5	Application of the Housing Provisions to a particular State or Territory	
1.1.6	Language	
1.1.7	Interpretation of diagrams	
1.1.8	Explanatory information	
1.2	Acceptance of design and construction	2,201
1.2.1	Suitability of materials	
1.2.2	Evidence of suitability	
1.2.3	Fire resistance of building elements	
1.2.4	Early fire hazard indices	
1.3	Classification of buildings	2,401
1.3.1	Principles of classification	
1.3.2	Classification	
1.3.3	Multiple Classifications	
1.4	Standards adopted by reference	2,601
1.4.1	Schedule of referenced documents	

PART 1.0 APPLICATION

1.0.1 Adoption

1.0.1
Amdt No. 2

The dates of adoption of the 1996 edition of the Building Code of Australia (Volume Two) and its amendments are shown in the “History of Amendments” division at the end of this Volume.

1.0.2 BCA Volumes

- (a) This is Volume Two of the Building Code of Australia 1996 (hereafter described as the Housing Provisions) which contains the requirements for-
 - (i) Class 1 and 10 buildings (other than access requirements for people with disabilities in Class 10 buildings); and
 - (ii) certain Class 10 structures.
- (b) Volume One contains the requirements for-
 - (i) all Class 2 to 9 buildings; and
 - (ii) access requirements for people with disabilities in Class 10 buildings (Part D3); and
 - (iii) certain Class 10 structures.

1.0.3 BCA Structure

The structure of the BCA comprises the following as shown in Figure 1.0.3:

- (a) The *Objectives*.
- (b) The *Functional Statements*.
- (c) The *Performance Requirements* with which all *Building Solutions* must comply.
- (d) The *Building Solutions*.

Amdt 11

Figure 1.0.3
THE BCA HIERARCHY

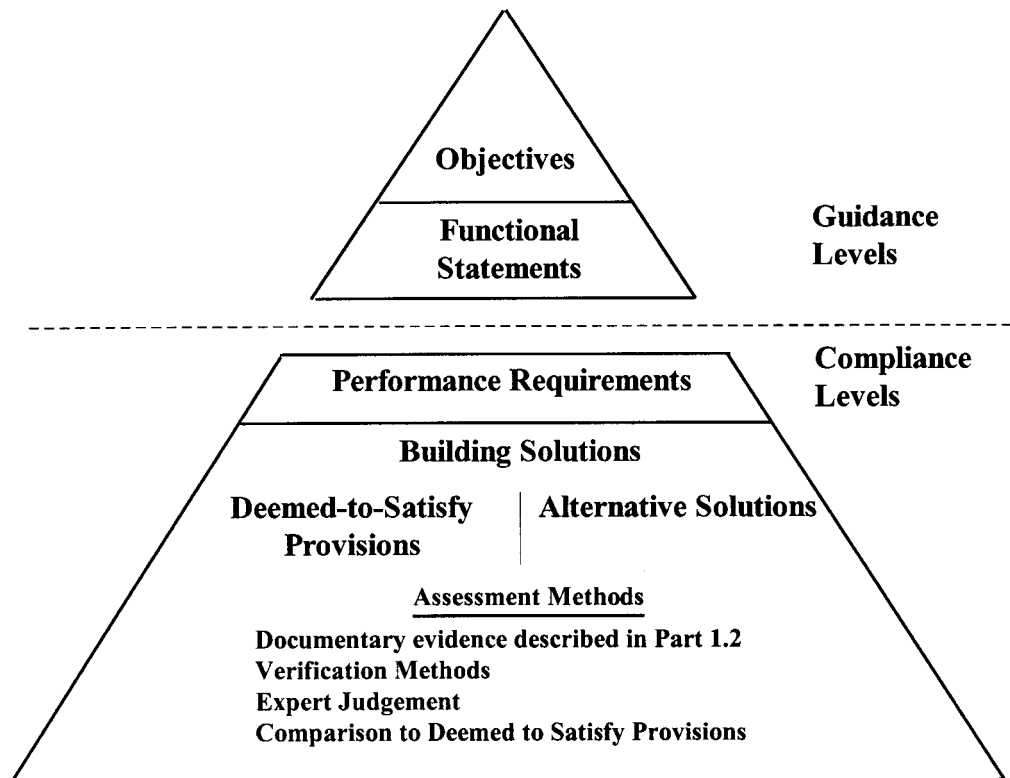

Amdt 11

1.0.4 Compliance with the BCA

A Building Solution will comply with the BCA if it satisfies the Performance Requirements.

1.0.5 Meeting the Performance Requirements

Compliance with the *Performance Requirements* can only be achieved by-

- (a) complying with the *Deemed-to-Satisfy Provisions*; or
- (b) formulating an *Alternative Solution* which-
 - (i) complies with the *Performance Requirements*; or
 - (ii) is shown to be at least *equivalent* to the *Deemed-to-Satisfy Provisions*;
or
- (c) a combination of (a) and (b).

1.0.6 Objectives and Functional Statements

The *Objectives* and *Functional Statements* may be used as an aid to interpretation.

1.0.7 Deemed-to-Satisfy Provisions

A *Building Solution* which complies with the *Deemed-to-Satisfy Provisions* is deemed to comply with the *Performance Requirements*.

1.0.8 Alternative Solutions

- (a) An *Alternative Solution* must be assessed according to one or more of the *Assessment Methods*.
- (b) An *Alternative Solution* will only comply with the BCA if the *Assessment Methods* used to determine compliance with the *Performance Requirements* have been satisfied.

1.0.9 Assessment Methods

The following *Assessment Methods*, or any combination of them, can be used to determine that a *Building Solution* complies with the *Performance Requirements*:

- (a) Evidence to support that the use of a material, form of construction or design meets a *Performance Requirement* or a *Deemed-to-Satisfy Provision* as described in 1.2.2.
- (b) *Verification Methods* such as-
 - (i) the *Verification Methods* in the BCA; or
 - (ii) such other *Verification Methods* as the *appropriate authority* accepts for determining compliance with the *Performance Requirements*.
- (c) Comparison with the *Deemed-to-Satisfy Provisions*.
- (d) *Expert Judgement*.

PART 1.1 INTERPRETATION

1.1.1 Definitions

1.1.1.1 In the *Housing Provisions*, definitions are contained as follows:

- (a) In 1.1.1 for definitions that apply to all of the *Housing Provisions*.
- (b) In each Part (as applicable) for definitions that apply to that Part only.

1.1.1.2 In the *Housing Provisions*, unless the contrary appears:

Alpine area means land-

- (a) likely to be subject to significant snowfalls; and
- (b) in New South Wales, ACT or Victoria more than 1200 m above the Australian Height Datum; and
- (c) in Tasmania more than 900 m above the Australian Height Datum.

Explanatory information:

See Part 3.7.5 for map of *alpine areas*.

Alteration, in relation to a building, includes an addition or extension to a building.

Alternative Solution means a *Building Solution* which complies with the *Performance Requirements* other than by reason of complying with the *Deemed-to-Satisfy Provisions*.

Appropriate authority means the relevant authority as determined by the building regulatory legislation in each State and Territory.

Assessment Method means a method used for determining or establishing that a *Building Solution* complies with the *Performance Requirements*.

Automatic, applied to a fire door, smoke door, solid core door, fire shutter, fire *window*, smoke-and-heat vent, sprinkler system, alarm system or the like, means designed to operate when activated by a heat, smoke or fire sensing device.

Average recurrence interval applied to rainfall, means the average or expected interval between events of a given rainfall intensity being exceeded.

Building Solution means a solution which complies with the *Performance Requirements* and is-

- (a) an *Alternative Solution*; or
- (b) a solution which complies with the *Deemed-to-Satisfy Provisions*; or
- (c) a combination of (a) and (b).

1.1.1.2
Amdt No. 11

Certificate of Accreditation means a certificate issued by a State or Territory accreditation authority stating that the properties and performance of a building material or method of construction or design fulfil specific requirements of the *Housing Provisions*.

1.1.1.2
Amdt No. 11

Certificate of Conformity means a certificate issued under the ABCB scheme for products and systems certification stating that the properties and performance of a building material or method of construction or design fulfil specific requirements of the *Housing Provisions*.

Combustible -

- (a) applied to a material - means *combustible* under AS 1530.1; or
- (b) applied to construction or part of a building - means constructed wholly or in part of *combustible* materials.

Common wall means a wall that is common to adjoining buildings other than Class 1 buildings.

1.1.1.2
Amdt No. 11

Construction activity actions means actions due to stacking of building materials or the use of equipment, including cranes and trucks, during construction or actions which may be induced by floor-to-floor propping.

1.1.1.2
Amdt No. 11

Damp-proof course (DPC) means a continuous layer of impervious material placed in a masonry wall or pier, or between a wall or pier and a floor, to prevent the upward or downward migration of water.

Deemed-to-Satisfy Provisions means provisions contained in Section 3 which are deemed to comply with the *Performance Requirements*.

1.1.1.2
Amdt No. 6

Designated bushfire prone area means land which has been designated under a power in legislation as being subject, or likely to be subject, to bushfires.

STATE AND TERRITORY VARIATIONS

NSW var
Amdt No. 6

Definition of designated bushfire prone area has been replaced in New South Wales as follows:

Designated bushfire prone area means land that:

- (a) has been designated under legislation; or
- (b) has been identified under an environmental planning instrument, development control plan or in the course of processing and determining a development application,

as land that can support a bushfire or is likely to be subject to bushfire attack.

1.1.1.2
Amdt No. 11

Design wind speed means the design gust wind speed for the area where the building is located, calculated in accordance with AS/NZS 1170.2 or AS 4055 (see Table 1.1.1 for *Housing Provisions design wind speed* descriptions and equivalent values).

Table 1.1.1
Amdt No. 11

Table 1.1.1
DESIGN WIND SPEED – EQUIVALENT VALUES

Note:

1. Wind classification map identifying cyclonic areas (as per AS 4055) is contained in Part 3.10.1.
2. Information on wind speeds for particular areas may be available from the *appropriate authority*.
3. = *design wind speed areas covered by Part 3.10.1, High wind areas.*

Housing Provisions description	EQUIVALENT VALUES			
	Wind Class – AS 4055			Design gust wind speed (m/sec)
	km/h	For non-cyclonic regions A and B	For cyclonic regions C and D	Permissible stress method only
W28	101	N1	-	28
W33	119	N2	-	33
W41	148	N3	C1	41
W50	180	N4	C2	50
W60	216	N5	C3	60
W70	252	N6	C4	70

Amdt 11

Equivalent means equivalent to the level of health, safety and amenity provided by the *Deemed-to-Satisfy Provisions*.

Expert Judgement means the judgement of an expert who has the qualifications and experience to determine whether a *Building Solution* complies with the *Performance Requirements*.

External wall means an outer wall of a building which is not a *separating wall*.

Fire-resistance level (FRL) means the grading periods in minutes determined in accordance with Specification A2.3 of BCA Volume One, for-

- (a) *structural adequacy*; and
- (b) *integrity*; and
- (c) *insulation*,

and expressed in that order.

A dash means there is no requirement for that criterion. For example, 90/-/- means there is no FRL for integrity and insulation.

Fire-resisting, applied to a *structural member* or other part of a building, means having the FRL *required* for that *structural member* or other part.

Flammability Index means the index number determined under AS 1530.2.

1.1.1.2
Amdt No. 11

Flashing means a strip or sleeve of impervious material dressed, fitted or built-in to provide a barrier to moisture movement, or to divert the travel of moisture, or to cover a joint where water would otherwise penetrate to the interior of a building.

Floor area means, in relation to a room, the area of the room measured within the finished surfaces of the walls, and includes the area occupied by any cupboard or other built-in furniture, fixture or fitting (see Figure 1.1.1).

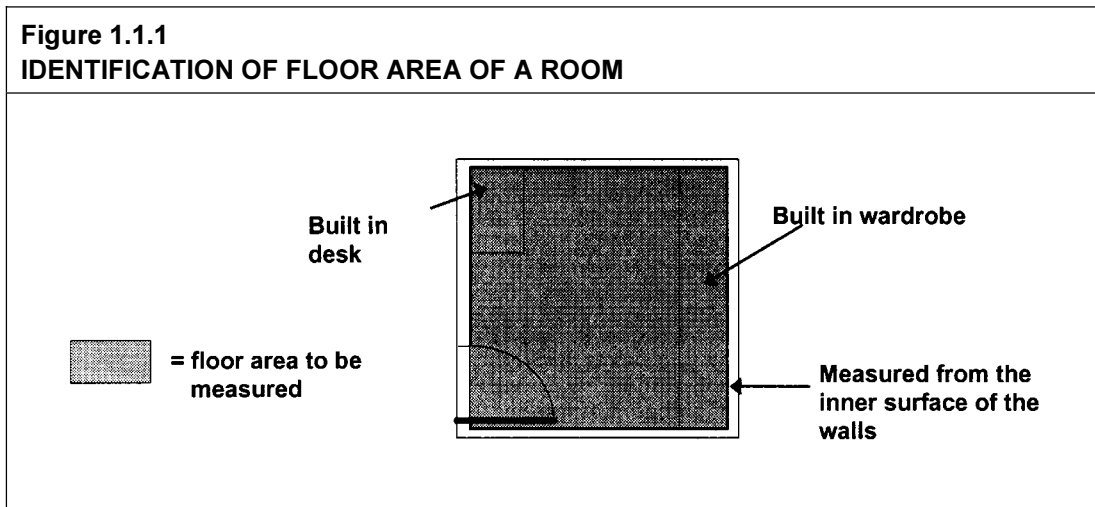

Amdt 11

Foundation means the ground which supports the building (see Figure 1.1.2).

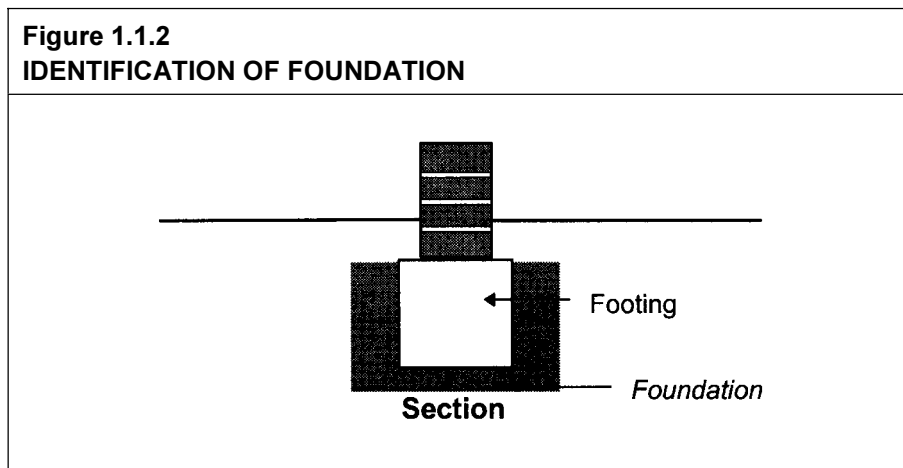

Functional Statement means a statement which describes how buildings and building elements achieve the *Objectives*.

Habitable room means a room used for normal domestic activities, and-

- (a) includes a bedroom, living room, lounge room, music room, television room, kitchen, dining room, sewing room, study, playroom, family room and sunroom; but
- (b) excludes a bathroom, laundry, water closet, pantry, walk-in wardrobe, corridor, hallway, lobby, photographic darkroom, clothes-drying room, and other spaces of a specialised nature occupied neither frequently nor for extended periods.

High wind area means a region that is subject to *design wind speeds* more than W41 (see Table 1.1.1).

Housing Provisions means the requirements for Class 1 and 10 buildings contained in Volume Two of the Building Code of Australia 1996 as published by the Australian Building Codes Board.

Illuminance means the luminous flux falling onto a unit area of surface.

Insulation, in relation to an FRL, means the ability to maintain a temperature on the surface not exposed to the furnace below the limits specified in AS 1530.4.

Integrity, in relation to an FRL, means the ability to resist the passage of flames and hot gases specified in AS 1530.4.

Internal wall excludes a *separating wall, common wall or party wall*.

Lightweight construction means construction which incorporates or comprises-

- (a) sheet or board material, plaster, render, sprayed application, or other material similarly susceptible to damage by impact, pressure or abrasion; or
- (b) concrete and concrete products containing pumice, perlite, vermiculite, or other soft material similarly susceptible to damage by impact, pressure or abrasion; or
- (c) masonry having a thickness less than 70 mm.

Loadbearing means intended to resist vertical forces additional to those due to its own weight.

Non-combustible -

- (a) applied to a material - means not deemed *combustible* under AS 1530.1 - Combustibility Tests for Materials; and
- (b) applied to construction or part of a building - means constructed wholly of materials that are not deemed *combustible*.

Objective means a statement contained in the BCA which is considered to reflect community expectations.

Other property means all or any of the following-

- (a) any building, whether or not on the same or an adjoining allotment; and
- (b) any adjoining allotment; and
- (c) a road.

Outdoor air means air outside the building.

Outfall means that part of the disposal system receiving *surface water* from the drainage system and may include a natural water course, kerb and channel, or soakage system.

Performance Requirement means a requirement which states the level of performance which a *Building Solution* must meet.

Private garage means-

- (a) any garage associated with a Class 1 building; or
- (b) any separate single storey garage associated with another building where such garage is capable of accommodating not more than 3 vehicles.

Professional engineer means a person who is-

- (a) if legislation is applicable - a registered *professional engineer* in the relevant discipline who has appropriate experience and competence in the relevant field; or
- (b) if legislation is not applicable-
 - (i) a Corporate Member of the Institution of Engineers, Australia; or
 - (ii) eligible to become a Corporate Member of the Institution of Engineers, Australia, and has appropriate experience and competence in the relevant field.

Registered Testing Authority means-

- (a) the National Building Technology Centre (NBTC); or
- (b) the CSIRO Division of Building, Construction and Engineering (CSIRO-DBC&E); or
- (c) an authority registered by the National Association of Testing Authorities (NATA) to test in the relevant field; or
- (d) an organisation outside Australia recognised by NATA through a mutual recognition agreement.

Required means required to satisfy a *Performance Requirement* or a *Deemed-to-Satisfy Provision* of the *Housing Provisions* as appropriate.

1.1.1.2
Amdt No. 5

Sanitary compartment means a room or space containing a closet pan or urinal.

Sarking-type material means a material such as a reflective foil or other flexible membrane of a type normally used for a purpose such as waterproofing, vapour proofing or thermal reflectance.

Self-closing, applied to a door or *window* means equipped with a device which returns the door or *window* to the fully closed and latched position immediately after each manual opening.

Separating wall means a wall that is common to adjoining Class 1 buildings (see Figure 1.1.3).

Figure 1.1.3
SEPARATING WALL

Note: May also be known as a party wall and typically is *required* to be *fire resisting* construction (see Part 3.7.1)

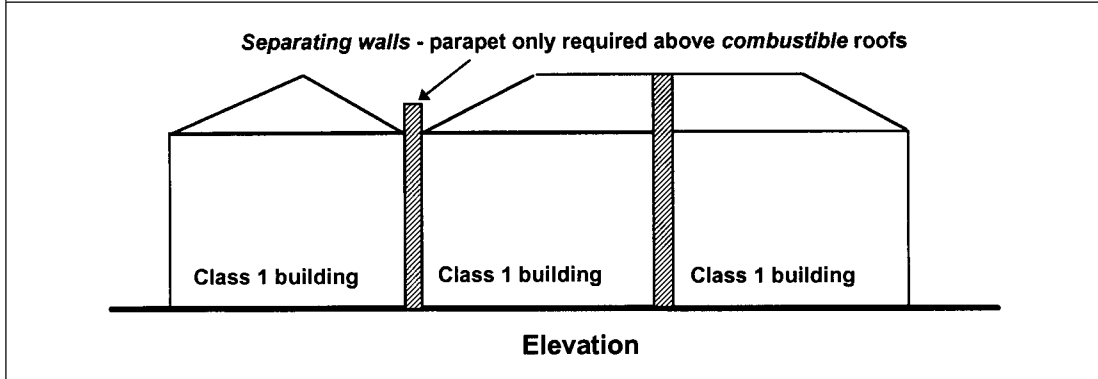

Amdt 11

Site means the part of the allotment of land on which a building stands or is to be erected.

Sitework means work on or around a *site*, including earthworks, preparatory to or associated with the construction, *alteration*, demolition or removal of a building.

1.1.1.2
Amdt No. 6

Smoke-Developed Index means the index number for smoke developed under AS/NZS 1530.3.

1.1.1.2
Amdt No. 6

Spread-of-Flame Index means the index number for spread of flame under AS/NZS 1530.3.

Standard Fire Test means the Fire-resistance Test of Elements of Building Construction as described in AS 1530.4.

Structural adequacy, in relation to an FRL, means the ability to maintain stability and adequate *loadbearing* capacity under AS 1530.4.

Structural member means a component or part of an assembly which provides vertical or lateral support to a building or structure.

Surface water means all naturally occurring water, other than sub-surface water, which results from rainfall on or around the *site* or water flowing onto the *site*, including that flowing from a drain, stream, river, lake or sea.

Swimming pool means any excavation or structure containing water and used principally for swimming, wading, paddling, or the like, including a bathing or wading pool, or spa.

Verification Method means a test, inspection, calculation or other method that determines whether a *Building Solution* complies with the relevant *Performance Requirements*.

Window includes a roof light, glass panel, glass block or brick, glass louvre, glazed sash, glazed door, or other device which transmits natural light directly from outside a building to the room concerned when in the closed position.

1.1.2 Adoption of referenced documents

Where a *Deemed-to-Satisfy Provision* adopts a Standard, rule, specification or provision included in any document issued by Standards Australia or other body, that adoption does not include a provision-

- (a) specifying or defining the respective rights, responsibilities or obligations as between themselves of any manufacturer, supplier or purchaser; or
- (b) specifying the responsibilities of any trades person or other building operative, architect, engineer, authority, or other person or body; or
- (c) requiring the submission for approval of any material, building component, form or method of construction, to any person, authority or body other than a person or body empowered under State or Territory legislation to give that approval; or
- (d) specifying that a material, building component, form or method of construction must be submitted to Standards Australia or a committee of Standards Australia for expression of opinion; or
- (e) permitting a departure from the code, rule, specification or provision at the sole discretion of the manufacturer or purchaser, or by arrangement or agreement between the manufacturer and purchaser.

1.1.3 Context of reference

A reference in a *Deemed-to-Satisfy Provision* to a document under 1.1.2 refers to the edition or issue, together with any amendment, listed in Part 1.4 and only so much as is relevant in the context in which the document is quoted.

1.1.4 Differences between referenced documents and the Housing Provisions

The *Housing Provisions* overrule in any difference arising between it and any Standard, rule, specification or provision in a document listed in Part 1.4.

1.1.5 Application of the Housing Provisions to a particular State or Territory

For application within a particular State or Territory, the *Housing Provisions* comprise-

- (a) Sections 1 to 3 (inclusive); and
- (b) the variations and deletions applicable to that State or Territory specified in Sections 1 to 3 inclusive; and
- (c) the additions to Sections 1 to 3 inclusive applicable to that State or Territory specified in the relevant Appendix.

1.1.6 Language

A reference to a building in the *Housing Provisions* is a reference to an entire building or part of a building, as the case requires.

1.1.7 Interpretation of diagrams

Diagrams in the *Housing Provisions* are used to describe specific issues referenced in the associated text. They are not to be construed as containing all design information that is *required* for that particular building element or situation.

Explanatory information:

Diagrams are used to explain the requirements of a particular clause. To ensure the context of the requirement is clearly understood, adjacent construction elements of the building that would normally be required in that particular situation are not always shown.

i.e. Diagrams to show the installation of *damp-proof courses* will only depict the *damp-proof course* and associated masonry. It will not necessarily show non-related items such as wall ties, adjacent timber flooring, reinforcing for any footing etc.

Accordingly, aspects of a diagram that are not shown should not be interpreted as meaning these construction details are not *required*.

1.1.8 Explanatory information

These elements of the *Housing Provisions* are non-mandatory. They are used to provide additional guidance on the application of the particular Parts and clauses and do not need to be followed to meet the requirements of the *Housing Provisions*.

PART 1.2 ACCEPTANCE OF DESIGN AND CONSTRUCTION

1.2.1 Suitability of materials

Every part of a building must be constructed in an appropriate manner to achieve the requirements of the *Housing Provisions*, using materials that are fit for the purpose for which they are intended.

1.2.2 Evidence of suitability

1.2.2
Amdt No. 11

- (a) Subject to 1.2.3 and 1.2.4, evidence to support that the use of a material, form of construction or design meets a *Performance Requirement* or a *Deemed-to-Satisfy Provision* may be in the form of one or a combination of the following:
- (i) A report issued by a *Registered Testing Authority*, showing that the material or form of construction has been submitted to the tests listed in the report, and setting out the results of those tests and any other relevant information that demonstrates its suitability for use in the building.
 - (ii) A current *Certificate of Conformity* or a current *Certificate of Accreditation*.
 - (iii) A certificate from a *professional engineer* or other appropriately qualified person which-
 - (A) certifies that a material, design or form of construction complies with the requirements of the *Housing Provisions*; and
 - (B) sets out the basis on which it is given and the extent to which relevant specifications, rules, codes of practice or other publications have been relied upon.
 - (iv) A current certificate issued by a product certification body that has been accredited by the Joint Accreditation Scheme of Australia and New Zealand (JAS-ANZ).
 - (v) A current SSL Product Listing Data Sheet and listing in the latest issue of the Scientific Services Laboratory Register of Accredited Products - Fire Protection Equipment.
 - (vi) Any other form of documentary evidence that correctly describes the properties and performance of the material or form of construction and adequately demonstrates its suitability for use in the building.
- (b) Any copy of documentary evidence submitted, must be a complete copy of the original report or document.

Amdt 11

1.2.3 Fire resistance of building elements

Where a *Deemed-to-Satisfy Provision* requires a building element to have an FRL, it must comply with the acceptable construction method or be determined in accordance with Specification A2.3 of BCA Volume One.

1.2.4 Early Fire Hazard Indices

Where a *Deemed-to-Satisfy Provision* requires a building component or assembly to have an Early Fire Hazard Index, it must be determined in accordance with Specification A2.4 of BCA Volume One.

Explanatory information:

The provisions of Part 1.2 list acceptable methods to enable verification and acceptance of both the performance (listed in Section 2) and deemed-to-satisfy options (listed in Section 3) of the *Housing Provisions*.

PART 1.3 CLASSIFICATION

1.3.1 Principles of classification

The classification of a building or part of a building is determined by the purpose for which it is designed, constructed or adapted to be used.

Explanatory information:

1. Class 1 and 10 buildings are classified in accordance with this Part; and
2. Class 2 to 9 buildings are classified in accordance with Section A of BCA, Volume One.

Amdt 11

1.3.2 Classification

Class 1 and 10 buildings are classified as follows:

Class 1 - one or more buildings, which in association constitute-

- (a) **Class 1a** - a single dwelling being-
 - (i) a detached house; or
 - (ii) one or more attached dwellings, each being a building, separated by a *fire-resisting* wall, including a row house, terrace house, town house or villa unit; or
- (b) **Class 1b** - a boarding house, guest house, hostel or the like with a total floor area not exceeding 300 m² and in which not more than 12 persons would ordinarily be resident;

which is not located above or below another dwelling or another Class of building other than a *private garage* (see Figure 1.3.1, 1.3.2 and 1.3.3).

Class 10 - a non-habitable building or structure being-

- (a) **Class 10a** - a non-habitable building being a *private garage*, carport, shed, or the like; or
- (b) **Class 10b** - a structure being a fence, mast, antenna, retaining or free-standing wall, *swimming pool*, or the like.

(see Figure 1.3.3).

Figure 1.3.1
IDENTIFICATION OF CLASS 1 BUILDINGS

Note: For fire-resisting construction between Class 1 buildings see Part 3.7.1.

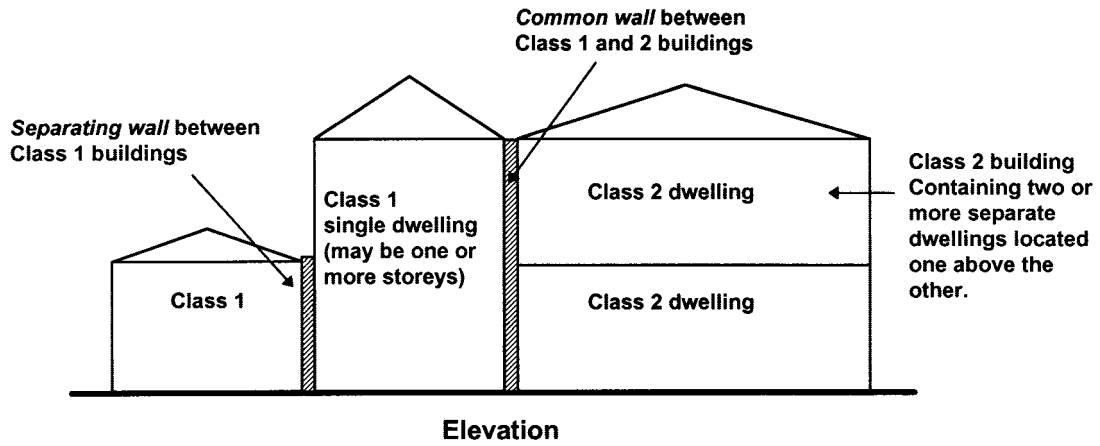
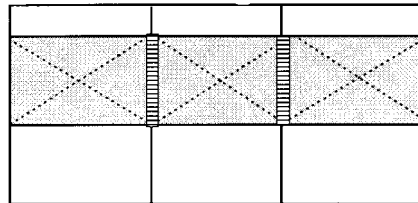
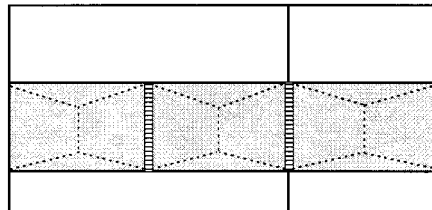

Figure 1.3.2
TYPICAL CLASS 1 CONFIGURATIONS

Note: Legend  = Separating wall



3 Class 1 buildings on 3 separate allotments



3 Class 1 buildings on 2 separate allotments

Plan view

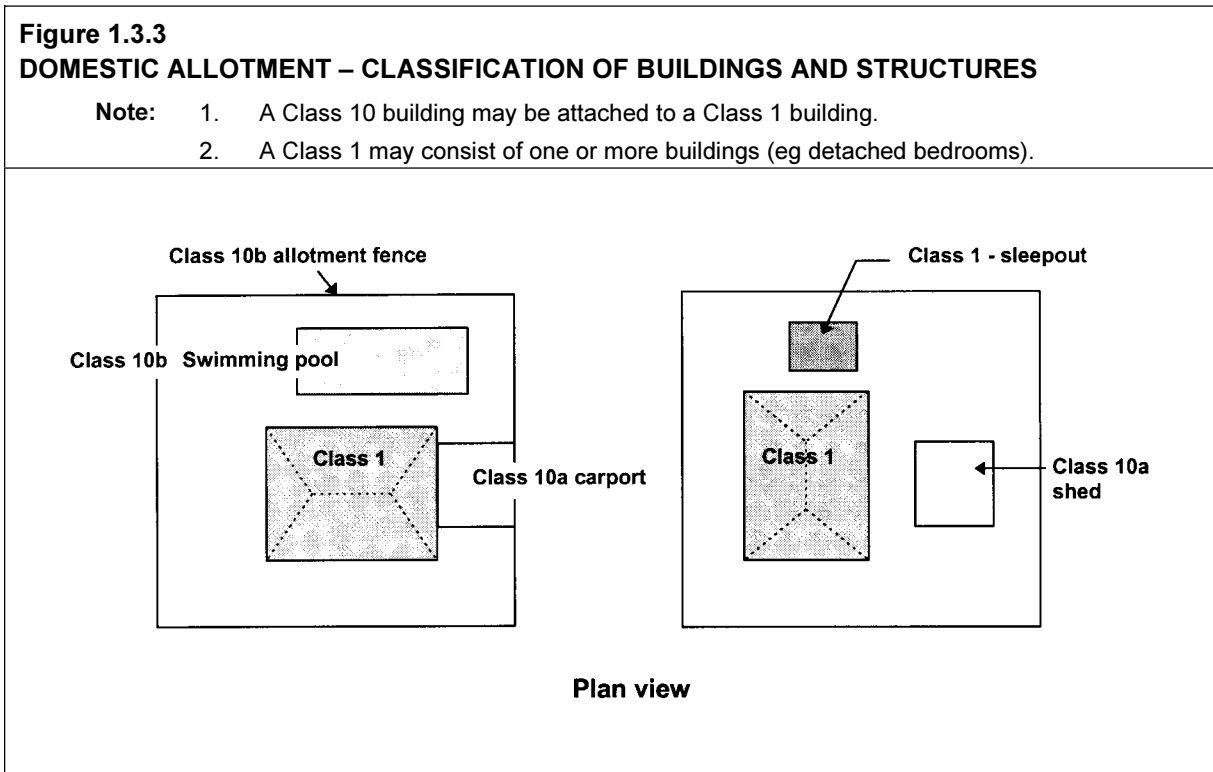

Amdt 11

1.3.3 Multiple classifications

Each part of a building must be classified separately, and-

- (a) Classes 1a, 1b, 10a and 10b are separate classifications; and
- (b) a reference to-
 - (i) Class 1 - is to Class 1a and 1b; and
 - (ii) Class 10 - is to Class 10a and 10b; and

1.3.3(C)
Amdt No. 2

- (c) where parts have different purposes - if not more than 10% of the *floor area* of a Class 1 building is used for a purpose which is a different classification, the classification of Class 1 may apply to the whole building.

PART 1.4 STANDARDS ADOPTED BY REFERENCE

1.4.1 Schedule of referenced documents

The Standards and other documents listed in Table 1.4.1 are referred to in the *Housing Provisions*.

**Table 1.4.1:
SCHEDULE OF REFERENCED DOCUMENTS**

No.	Date	Title
AS/NZS 1170 Amdt No. 11	AS/NZS 1170	Structural design actions
	Part 0	2002 General principles
	Part 1	2002 Permanent, imposed and other actions
	Part 2	2002 Wind actions
AS 1170 Amdt No. 11	AS 1170	Minimum design loads on structures
	Part 3	1990 Snow loads
	Part 4	1993 Earthquake loads Amdt 1, Oct. 1994
AS/NZS 1200 Amdt No. 8	AS/NZS 1200	2000 Pressure equipment
Deletions Amdt No. 6	AS 1273	1991 Unplasticized PVC (UPVC) downpipe and fittings for rainwater
AS/NZS 1276.1 Amdt No. 9	AS/NZS 1276	Acoustics - Rating of sound installation in buildings and of building elements
	Part 1	1999 Airborne sound insulation [Note: Test reports based on AS 1276 - 1979 and issued prior to AS/NZS 1276.1 - 1999 being referenced in the BCA, remain valid. The STC values in reports based on AS 1276 - 1979 shall be considered to be equivalent to R _w values. Test reports prepared after the BCA reference date for AS/NZS 1276.1 - 1999 must be based on that version.]
AS 1288 Amdt No. 8	AS 1288	1994 Glass in buildings - Selection and Installation Amdt 1, Sept. 1997 Amdt 2, Dec. 2000
AS 1289 Amdt No. 2	AS 1289	Methods of testing soils for engineering purposes
AS 1397 Amdt No. 11	Method 6.3.3	1997 Determination of the penetration resistance of a soil - Perth sand penetrometer test
	AS 1397	2001 Steel sheet and strip - Hot-dipped zinc-coated or aluminium/zinc-coated

Amdt 11

Table 1.4.1: SCHEDULE OF REFERENCED DOCUMENTS (Continued)		
No.	Date	Title
AS 1530		Methods for fire tests on building materials components and structures
Part 1	1994	Combustibility test for materials
Part 2	1993	Test for flammability of materials Amdt 1, July 1993
Part 4	1997	Fire-resistance tests on elements of building construction [Note: Subject to the note to AS 4072.1, reports relating to tests carried out under earlier editions of AS 1530 Parts 1 to 4 remain valid. Reports relating to tests carried out after the date of an amendment to a Standard must relate to the amended Standard]
AS/NZS 1530		Methods for fire tests on building materials, components and structures
Part 3	1999	Simultaneous determination of ignitability, flame propagation, heat release and smoke release
AS 1562		Design and installation of sheet roof and wall cladding
Part 1	1992	Metal Amdt 1, July 1993 Amdt 2, Sept. 1995
AS/NZS 1562		Design and installation of sheet roof and wall cladding
Part 2	1999	Corrugated fibre-reinforced cement
Part 3	1996	Plastics
AS 1657	1992	Fixed platforms, walkways, stairways and ladders - Design, construction and installation (SAA Code for Fixed Platforms, Walkways, Stairways and Ladders)
AS/NZS 1664		Aluminium structures
Part 1	1997	Limit state design Amdt 1, Jan. 1999
Part 2	1997	Allowable stress design Amdt 1, Jan. 1999
AS 1668		The use of mechanical ventilation and air-conditioning in buildings
Part 2	1991	Mechanical ventilation for acceptable indoor-air quality
AS 1680		Interior lighting
Part 1	1990	General principles and recommendations Amdt 1, June 1993
Part 2.0	1990	Recommendations for specific tasks and interiors Amdt 1, Dec. 1992
Part 2.1	1993	Circulation space and other general areas

AS 1530.4
Amdt No. 4

AS/NZS 1530
Amdt No. 6

AS/NZS 1562.2
Amdt No. 6

AS/NZS 1562.3
Amdt No. 4

Deletions
Amdt No. 6

AS/NZS 1664
Amdt No. 5

Amdt 11

**Table 1.4.1:
SCHEDULE OF REFERENCED DOCUMENTS (Continued)**

No.	Date	Title		
AS 1684.2, 3 & 4 Amdt No. 11	AS 1684 Part 2	1999 Residential timber-framed construction Non-cyclonic areas Amdt 1, April 2000 Amdt 2, Oct. 2000 Amdt 3, May 2001 Amdt 4, May 2002		
		Part 3	1999 Cyclonic areas Amdt 1, April 2000 Amdt 2, Oct. 2000 Amdt 3, May 2001 Amdt 4, May 2002	
			Part 4	1999 Simplified - Non-cyclonic areas Amdt 1, April 2000 Amdt 2, Oct. 2000 Amdt 3, May 2001 Amdt 4, May 2002
				AS 1691
	AS 1720			
		Part 1		1997 Design methods Amdt 1, July 1998 Amdt 2, May 2000 Amdt 3, April 2001
			AS 1926	Swimming pool safety
	Part 1			1993 Fencing for swimming pools Amdt 1, June 2000
		Part 2	1995 Location of fencing for private swimming pools	
	AS 2047		1999 Windows in buildings - Selection and installation Amdt 1, Jan. 2001 Amdt 2, June 2001	
		AS 2049	1992 Roof tiles	
	AS 2050	AS 2050	1995 Installation of roof tiles Amdt 1, Sept. 1995 Amdt 2, June 1999	
AS 2159			1995 Piling – Design and installation Amdt 1, April 1996	
AS/NZS 2179	Part 1	1994 Specification for rainwater goods, accessories and fasteners Metal shape or sheet rainwater goods and metal accessories and fasteners		

Amdt 11

Table 1.4.1: SCHEDULE OF REFERENCED DOCUMENTS (Continued)		
No.	Date	Title
AS/NZS 2269	1994	Plywood-structural Amdt 1, Oct. 1996
AS 2327		Composite construction in structural steel and concrete (SAA Composite Construction Code)
Part 1	1996	Simply supported beams
AS/NZS 2699		Built in components for masonry construction
Part 1	2000	Wall ties
AS 2867	1986	Farm structures - General requirements for structural design
AS 2870	1996	Residential slabs and footings - Construction Amdt 1, Jan. 1997 Amdt 2, June 1999
AS/NZS 2904	1995	Damp-proof courses and flashings Amdt 1, March 1998
AS/NZS 2908		Cellulose cement products
Part 1	2000	Corrugated sheets
Part 2	2000	Flat sheets
AS/NZS 2918	2001	Domestic solid fuel burning appliances - Installation
AS/NZS 3500		National plumbing and drainage code
Part 3.2	1998	Storm water drainage - Acceptable solutions Amdt 1, Nov. 1998
Part 5	2000	Domestic installations
AS 3600	2001	Concrete structures Amdt 1, May 2002
AS 3623	1993	Domestic metal framing
AS 3660		Termite management
Part 1	2000	New building work
AS 3700	2001	Masonry structures Amdt 1, May 2002
AS 3740	1994	Waterproofing of wet areas in residential buildings Amdt 1, Sept. 1995
AS 3786	1993	Smoke alarms Amdt 1, April 1994 Amdt 2, Dec. 1995 Amdt 3, Nov. 2001
AS 3798	1996	Guidelines on earthworks for commercial and residential developments

Deletion
Amdt No. 9
AS/NZS 2269
Amdt No. 9

AS/NZS 2699
Amdt No. 7

AS 2870
Amdt No. 5

AS/NZS 2904
Amdt No. 3

AS/NZS 2908
Amdt No. 8

AS/NZS 2918
Amdt No. 10

AS/NZS 3500
Amdt No. 8

Deletions
Amdt No. 8

AS 3600
Amdt No. 11

AS 3660.1
Amdt No. 8

AS 3700
Amdt No. 11

AS 3786
Amdt No. 10

AS 3798
Amdt No. 2

Amdt 11

Table 1.4.1:

SCHEDULE OF REFERENCED DOCUMENTS (Continued)

	No.	Date	Title
AS/NZS 3837 Amdt No. 10	AS/NZS 3837	1998	Method of test for heat and smoke release rates for materials and products using an oxygen consumption calorimeter
AS 3959 Amdt No. 9	AS 3959	1999	Construction of buildings in bushfire-prone areas Amdt 1, Dec. 2000 Amdt 2, June 2001
	AS 4055	1992	Wind loads for housing Amdt 1, Dec. 1994
AS 4100 Amdt No. 3	AS 4100	1998	Steel Structures
	AS/NZS 4200		Pliable building membranes and underlays
	Part 1	1994	Materials Amdt 1, Dec. 1994
	Part 2	1994	Installation requirements
AS 4254 Amdt No. 8	AS 4254	1995	Ductwork for air-handling systems in buildings Amdt 1, Nov. 1996 Amdt 2, July 1999
	AS/NZS 4256		Plastic roof and wall cladding material
	Part 1	1994	General requirements
	Part 2	1994	Unplasticized polyvinyl chloride (UPVC) building sheets
Deletions Amdt No. 2	Part 3	1994	Glass fibre reinforced polyester (GRP)
	Part 5	1996	Polycarbonate
	AS/NZS 4600	1996	Cold-formed steel structures
ASTM D2898 Amdt No. 7	ASTM D2898	1996	Standard test methods for accelerated weathering of fire-retardant-treated wood for fire testing W1
Deletions Amdt No. 2	ASTM D3018-90	1994	Class A asphalt shingles surfaced with mineral granules
Deletions Amdt No. 9			
	CSIRO - NBTC	1987	Bulletin 5 - Earth-wall Construction 4th edition
ISO 717.1 Amdt No. 8	ISO 717		Acoustics – Rating of sound insulation in buildings and of building elements
	Part 1	1996	Airborne sound insulation
ISO 8336 Amdt No. 8	ISO 8336	1993E	Fibre cement flat sheets
	Northern Territory Deemed to comply Standards manual		
	SSL		Register of Accredited Products - Fire Protection Equipment
Deletions Amdt No. 8	TN 61		Cement and Concrete Association of Australia - Articulated walling

Amdt 11

STATE AND TERRITORY VARIATIONS – SCHEDULE OF REFERENCED DOCUMENTS

AUSTRALIAN CAPITAL TERRITORY REFERENCED DOCUMENTS

No.	Date	Title
		Development Control Code for Best Practice Waste Management in the ACT
		Worksafe Australia Asbestos Code of Practice and Guidance Notes, August 1998

Amdt No. 6

NEW SOUTH WALES REFERENCED DOCUMENTS

AS 1926		Swimming Pool Safety
Part 3	1993	Water recirculation and filtration systems

AS 1926.3
Amdt No. 11

SOUTH AUSTRALIAN REFERENCED DOCUMENTS

South Australian Housing Code 1998 (As amended)

* * * * *

SA F1.7	1998	South Australian Minister's Specification - Waterproofing of wet areas in buildings
----------------	------	---

SA 2.1
Amdt No. 10

SA F1.7
Amdt No. 3

AS 1428		Design for access and mobility
Part 1	2001	General requirements for access - New building work

AS 1428.1
Amdt No. 11

AS 1926		Swimming Pool Safety
Part 3	1993	Water recirculation and filtration systems

AS 1926.3
Amdt No. 2

VICTORIAN REFERENCED DOCUMENTS

FirstRate house energy rating software		Sustainable Energy Authority Victoria 2001
---	--	--

VIC
Amdt No. 10

TASMANIAN REFERENCED DOCUMENTS

AS 1926		Swimming Pool Safety
Part 3	1993	Water recirculation and filtration systems

AS 1926.3
Amdt No. 2

Amdt 11

SECTION **2**

Amdt 11

PERFORMANCE PROVISIONS

Objectives

Functional Statements

Performance Requirements

- 2.1 Structure**
- 2.2 Damp and weatherproofing**
- 2.3 Fire safety**
- 2.4 Health and amenity**
- 2.5 Safe movement and access**

SECTION 2 CONTENTS

	Page
2.0 Application	3,021
2.1 Structure	3,031
P2.1 Structural stability and resistance to actions	
2.2 Damp and weatherproofing	3,201
P2.2.1 Surface water	
P2.2.2 Weatherproofing	
P2.2.3 Dampness	
P2.2.4 Drainage from swimming pools	
2.3 Fire safety	3,401
P2.3.1 Protection from the spread of fire	
P2.3.2 Fire detection and early warning	
P2.3.3 Heating appliances	
P2.3.4 Bushfire areas	
P2.3.5 Alpine areas	
2.4 Health and amenity	3,601
P2.4.1 Wet areas	
P2.4.2 Room heights	
P2.4.3 Facilities	
P2.4.4 Light	
P2.4.5 Ventilation	
P2.4.6 Sound insulation	
2.5 Safe movement and access	3,801
P2.5.1 Stairways and ramps	
P2.5.2 Barriers	
P2.5.3 Swimming pool access	

PART 2.0 APPLICATION

2.0 Application

- (a) This Section contains the *Objectives, Functional Statements* and *Performance Requirements* for Class 1 and 10 buildings (other than access requirements for people with disabilities in Class 10 buildings).
- (b) For the purposes of this Section a reference to a building includes a reference to both Class 1 and 10 buildings unless otherwise specified.

Note: Access requirements for people with disabilities in Class 10 buildings are contained in Part D3 of the BCA Volume One.

Amdt 11

PART 2.1 STRUCTURE

OBJECTIVE

O2.1 The *Objective* is to-

- (a) safeguard people from injury caused by structural failure; and
- (b) safeguard people from loss of amenity caused by structural behaviour; and
- (c) protect *other property* from physical damage caused by structural failure.

Qld var.
Amdt No. 8

STATE AND TERRITORY VARIATIONS

In Queensland delete O2.1(c) and insert O2.1(c) and (d) as follows:

- (c) protect *other property* from physical damage caused by structural failure; and
- (d) reduce the likelihood of buildings being damaged by subterranean termites.

Amdt 11

FUNCTIONAL STATEMENT

F2.1 A building or structure is to withstand the combination of loads and other actions to which it may be reasonably subjected.

PERFORMANCE REQUIREMENT

P2.1 Structural stability and resistance to actions

P2.1
Amdt No. 11

- (a) A building or structure, to the degree necessary, must-
 - (i) remain stable and not collapse; and
 - (ii) prevent progressive collapse; and
 - (iii) minimise local damage and loss of amenity through excessive deformation, vibration or degradation; and
 - (iv) avoid causing damage to *other properties*;
 by resisting the actions to which it may reasonably be subjected.
- (b) The actions to be considered to satisfy (a) include but are not limited to-
 - (i) permanent actions (dead loads); and
 - (ii) imposed actions (live loads arising from occupancy and use); and
 - (iii) wind action; and
 - (iv) earthquake action; and

- (v) snow action; and
 - (vi) liquid pressure action; and
 - (vii) ground water action; and
 - (viii) rainwater action (including ponding action); and
 - (ix) earth pressure action; and
 - (x) differential movement; and
 - (xi) time dependent effects (including creep and shrinkage); and
 - (xii) thermal effects; and
 - (xiii) ground movement caused by-
 - (A) swelling, shrinkage or freezing of the subsoil; and
 - (B) landslip or subsidence; and
 - (C) siteworks associated with the building or structure; and
 - (xiv) *construction activity actions*.
- (c) The structural resistance of materials and forms of construction must be determined using five percentile characteristic material properties with appropriate allowance for-
- (i) known construction activities; and
 - (ii) type of material; and
 - (iii) characteristics of the site; and
 - (iv) the degree of accuracy inherent in the methods used to assess the structural behaviour; and
 - (v) action effects arising from the differential settlement of foundations, and from restrained dimensional changes due to temperature, moisture, shrinkage, creep and similar effects.

STATE AND TERRITORY VARIATIONS

In Queensland after P2.1 insert P2.1.1 as follows:

- P2.1.1** All *primary building elements* of a Class 1 and 10 building must be protected against damage by subterranean termites by a suitable termite management system appropriate to-
- (a) the ability to replenish the termite management system if it relies on replenishment; and
 - (b) the level of accessibility to enable the installation, maintenance and inspection of the termite management system to be carried out; and
 - (c) the likelihood of the termite management system inadvertently being damaged or bridged.

PART 2.2 DAMP AND WEATHERPROOFING

OBJECTIVE

O2.2 The *Objective* is to-

- (a) safeguard occupants from illness or injury and protect the building from damage caused by-
 - (i) *surface water*; and
 - (ii) external moisture entering a building; and
 - (iii) the accumulation of internal moisture in a building; and
 - (iv) discharge of *swimming pool* waste water; and
- (b) protect *other property* from damage caused by-
 - (i) redirected *surface water*; and
 - (ii) the discharge of *swimming pool* waste water.

Amdt 11

STATE AND TERRITORY VARIATIONS

O2.2(a)(iv) and O2.2(b)(ii) do not apply in the Northern Territory.

FUNCTIONAL STATEMENT

F2.2.1 Surface water

A building including any associated *sitework* is to be constructed in a way that protects people and *other property* from the adverse effects of redirected *surface water*.

F2.2.2 Weatherproofing and dampness

F2.2.2
Amdt No. 5

A building is to be constructed to provide resistance to moisture from the outside and moisture rising from the ground.

Limitation:

F2.2.2 does not apply to a Class 10 building except where its construction contributes to the weatherproofing of the Class 1 building.

F2.2.3 Drainage from swimming pools

Adequate means for the disposal of *swimming pool* water and drainage is to be provided to a *swimming pool*.

Note:

The *Housing Provisions* do not contain any *Deemed-to-Satisfy Provisions* for this *Performance Requirement*.

STATE AND TERRITORY VARIATIONS

F2.2.3 does not apply in the Northern Territory.

Amdt 11**PERFORMANCE REQUIREMENT****P2.2.1 Surface water**

P2.2.1
Amdt No. 5

- (a) *Surface water*, resulting from a storm having an *average recurrence interval* of 20 years and which is collected or concentrated by a building or *sitework*, must be disposed of in a way that avoids the likelihood of damage or nuisance to any *other property*.
- (b) *Surface water*, resulting from a storm having an *average recurrence interval* of 100 years must not enter the building.

Limitation:

P2.2.1(b) does not apply to a Class 10 building where in the particular case there is no necessity for compliance.

- (c) A drainage system for the disposal of *surface water* must-
 - (i) convey *surface water* to an appropriate *outfall*; and
 - (ii) avoid the entry of water into a building; and
 - (iii) avoid water damaging the building.

P2.2.2 Weatherproofing

P2.2.2
Amdt No. 5

A roof and *external wall* (including openings around *windows* and doors) must prevent the penetration of water that could cause-

- (a) unhealthy or dangerous conditions, or loss of amenity for occupants; and
- (b) undue dampness or deterioration of building elements.

Limitation:

P2.2.2.(a) does not apply to a Class 10 building except where its construction contributes to the weatherproofing of the Class 1 building.

P2.2.3 Dampness

Moisture from the ground must be prevented from causing-

- (a) unhealthy or dangerous conditions, or loss of amenity for occupants; and
- (b) undue dampness or deterioration of building elements.

Limitation:

P2.2.3 does not apply to a Class 10 building where in the particular case there is no necessity for compliance.

Amdt 11**STATE AND TERRITORY VARIATIONS**

P2.2.3 has been replaced in South Australia as follows.

P2.2.3 Dampness

- (a) Moisture from the ground must be prevented from causing-
 - (i) undue dampness or deterioration of building elements; and
 - (ii) unhealthy or dangerous conditions, or loss of amenity for occupants.
- (b) Barriers installed to prevent transfer of moisture from the ground must have-
 - (i) high resistance to moisture penetration; and
 - (ii) high resistance to damage during construction; and
 - (iii) high resistance to degradation by dissolved salts.

P2.2.4 Drainage from swimming pools

A *swimming pool* must have adequate means of draining the pool in a manner which will not-

- (a) cause illness to people; or
- (b) affect *other property*.

Note:

The *Housing Provisions* do not contain any *Deemed-to-Satisfy Provisions* for this *Performance Requirement*.

STATE AND TERRITORY VARIATIONS

P2.2.4 does not apply in the Northern Territory.

PART 2.3 FIRE SAFETY

OBJECTIVE

O2.3 The *Objective* is to-

- (a) safeguard the occupants from illness or injury-
 - (i) by alerting them of a fire in the building so that they may safely evacuate; and
 - (ii) caused by fire from heating appliances installed within the building; and
 - (iii) in *alpine areas*, from an emergency while evacuating the building; and
- (b) avoid the spread of fire; and
- (c) protect a building from the effects of a bushfire.

FUNCTIONAL STATEMENT

F2.3.1 Protection from the spread of fire

A Class 1 building is to be protected from the spread of fire.

F2.3.2 Fire detection and early warning

A Class 1 building is to be provided with safeguards so that occupants are warned of a fire in the building so that they may safely evacuate.

F2.3.3 Heating appliances

Heating appliances using controlled combustion located in a building are to be installed in a way which reduces the likelihood of-

- (a) fire spreading beyond the appliance; and
- (b) smoke from the appliance entering the building.

F2.3.4 Bushfire areas

A Class 1 building constructed in a *designated bushfire prone area* is to provide resistance to bushfires in order to reduce the danger to life and reduce the risk of the loss of the building.

F2.3.5 Alpine areas

A building in an *alpine area* is to be provided with additional measures in view of the increased difficulties in fighting fire and maintaining access and means of egress in snow conditions.

Amdt 11

PERFORMANCE REQUIREMENT

P2.3.1 Protection from the spread of fire

- (a) A Class 1 building must be protected from the spread of fire from-
 - (i) another building other than an associated Class 10 building; and
 - (ii) the allotment boundary, other than a boundary adjoining a road or public space.
 (see Figure 2.3.1)
- (b) A Class 10a building must not significantly increase the risk of fire spread between Class 2 to 9 buildings.

Amdt 11

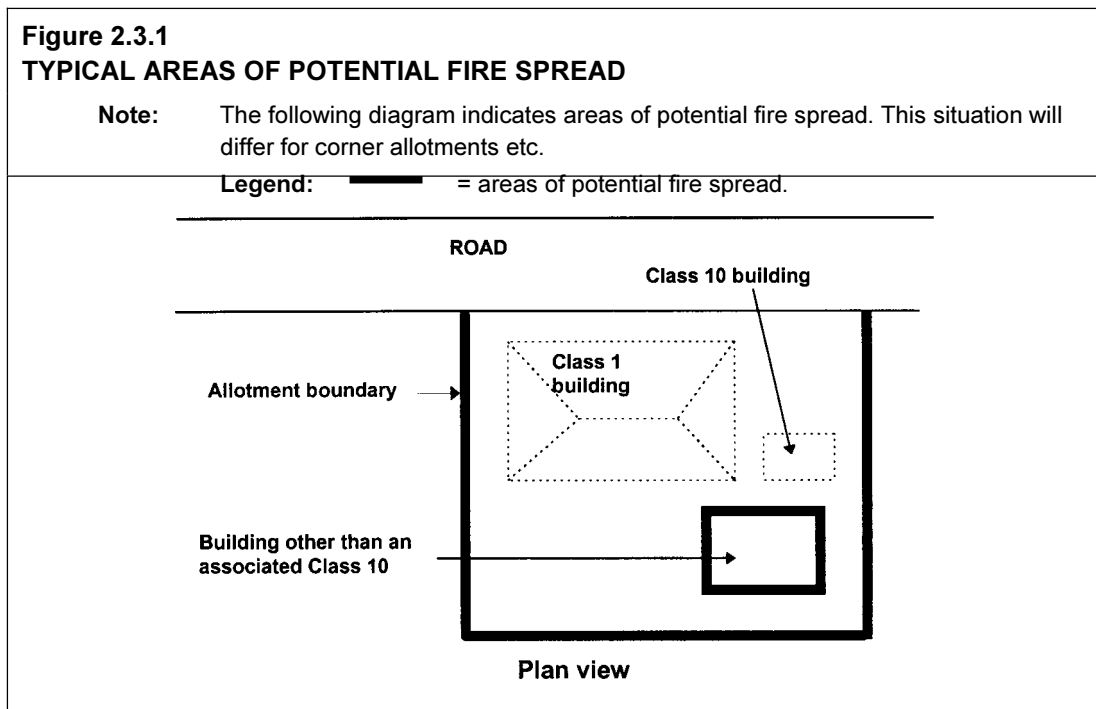

P2.3.2 Fire detection and early warning

In a Class 1 building, occupants must be provided with *automatic* warning on the detection of smoke so that they may evacuate in the event of a fire to a place of safety.

P2.3.3 Heating appliances

A heating appliance and its associated components within a building, including an open fire-place, chimney, or the like, must be installed-

- (a) to withstand the temperatures likely to be generated by the appliance; and
- (b) so that it does not raise the temperature of any building element to a level that would adversely affect the element's physical or mechanical properties or function; and
- (c) so that hot products of combustion will not-
 - (i) escape through the walls of the associated components; and
 - (ii) discharge in a position that will cause fire to spread to nearby *combustible* materials or allow smoke to penetrate through nearby *windows*, ventilation inlets, or the like in the building containing the heating appliance.

P2.3.4 Bushfire areas

P2.3.4
Amdt No. 6

A Class 1 building that is constructed in a *designated bushfire prone area* must be designed and constructed to reduce the risk of ignition from a bushfire while the fire front passes.

P2.3.5 Alpine areas

- (a) An external doorway from a building in an *alpine area* must be installed so that opening the door is not obstructed by snow or ice.
- (b) A building in an *alpine area* containing external trafficable structures forming part of the means of egress must be constructed so that they remain, as far as practicable, useable under snow conditions.
- (c) A building in an *alpine area* must be constructed so that snow or ice is not shed from the building onto the allotment, any adjoining allotment, road or public space in a location or manner that will-
 - (i) obstruct a means of egress from any building to a road or *open space*;
or
 - (ii) otherwise endanger people.

PART 2.4 HEALTH AND AMENITY

OBJECTIVE

O2.4.1 Wet areas

The *Objective* is to safeguard the occupants from illness or injury and protect the building from damage caused by the accumulation of internal moisture arising from the use of *wet areas* in a building.

O2.4.2 Room heights

The *Objective* is to safeguard the occupants from injury or loss of amenity caused by inadequate height of a room or space.

O2.4.3 Facilities

O2.4.3
Amdt No. 3

The *Objective* is to-

- (a) safeguard occupants from illness caused by infection; and
- (b) safeguard occupants from loss of amenity arising from the absence of adequate personal hygiene facilities; and
- (c) enable occupants to carry out laundering; and
- (d) provide for facilities to enable food preparation; and
- (e) enable unconscious occupants of *sanitary compartments* to be removed from the compartment.

O2.4.4 Light

The *Objective* is to safeguard occupants from injury, illness or loss of amenity due to-

- (a) isolation from natural light; and
- (b) lack of adequate artificial lighting.

O2.4.5 Ventilation

The *Objective* is to safeguard occupants from illness or loss of amenity due to lack of air freshness.

O2.4.6 Sound insulation

The *Objective* is to safeguard occupants from illness or loss of amenity as a result of undue sound being transmitted between adjoining dwellings.

Amdt 11

FUNCTIONAL STATEMENT**F2.4.1 Wet areas**

A building is to be constructed to avoid the likelihood of-

- (a) the creation of any unhealthy or dangerous conditions; or
- (b) damage to building elements,

caused by dampness or water overflow from bathrooms, laundries and the like.

F2.4.2 Room heights

A building is to be constructed to provide height in a room or space suitable for the intended use.

F2.4.3 Facilities

F2.4.3 A building is to be provided with suitable-

Amdt No. 3

- (a) space and facilities for personal hygiene; and
- (b) space and facilities for laundering; and
- (c) space and facilities for the preparation and cooking of food; and
- (d) space or other means to permit an unconscious occupant to be removed from a *sanitary compartment*.

Application:

F2.4.3 only applies to a Class 1 building.

F2.4.4 Light

- (a) A *habitable room* within a building is to be provided with openings to admit adequate natural light consistent with its function or use; and
- (b) a space within a building used by occupants is to be provided with artificial lighting consistent with its function or use which, when activated in the absence of suitable natural light, will enable safe use and movement.

F2.4.5 Ventilation

A space used by occupants within a building is to be provided with adequate ventilation consistent with its function or use.

F2.4.6 Sound insulation

A building element which separates dwellings is to be constructed to prevent undue sound transmission between those dwellings.

PERFORMANCE REQUIREMENT**P2.4.1 Wet areas**

To protect the structure of the building and to maintain the amenity of the occupants, water must be prevented from penetrating-

- (a) behind fittings and linings; or
 - (b) into concealed spaces,
- of sanitary facilities, bathrooms, laundries and the like.

P2.4.2 Room heights

A room or space must be of a height that does not unduly interfere with its intended function.

P2.4.3 Facilities

P2.4.3
Amdt No. 3

- (a) Suitable sanitary facilities for personal hygiene must be provided in a convenient location within or associated with a building, appropriate to its function or use.

- (b) * * * * *

This clause has been deliberately left blank.

- (c) Laundering facilities or space for laundering facilities must be provided in a convenient location within or associated with a building, appropriate to its function or use.
- (d) A food preparation facility must be provided which includes-
 - (i) a means for food rinsing, utensil washing and waste water disposal; and
 - (ii) a means for cooking food; and
 - (iii) a space for food preparation.
- (e) A *sanitary compartment* must be constructed with sufficient space or other means to enable an unconscious occupant to be removed from the compartment.

Application:

P2.4.3 only applies to a Class 1 building.

P2.4.4 Light

- (a) A *habitable room* must be provided with *windows* so that natural light, when available, provides a level of *illuminance* appropriate to the function or use of that part of the building.
- (b) Artificial lighting must be installed to provide a level of *illuminance* appropriate to the function or use of the building to enable safe use and movement by occupants.

Application:

P2.4.4(b) only applies-

- (a) to *sanitary compartments*, bathrooms, shower rooms, airlocks, laundries and the like; and
- (b) if natural lighting of a suitable standard is not available.

Amdt 11**P2.4.5 Ventilation**

- (a) A space within a building used by occupants must be provided with means of ventilation with *outdoor air* which will maintain adequate air quality.
- (b) A mechanical air-handling system installed in a building must control-
 - (i) the circulation of objectionable odours; and
 - (ii) the accumulation of harmful contamination by micro-organisms, pathogens and toxins.
- (c) Contaminated air must be disposed of in a manner which does not unduly create a nuisance or hazard to people in the building or *other property*.

P2.4.6 Sound insulation

- (a) Walls separating dwellings must provide insulation against the transmission of airborne and impact generated sound sufficient to prevent illness or loss of amenity to the occupants.
- (b) The *required* sound insulation of walls must not be compromised by the incorporation or penetration of a pipe or other service element.

PART 2.5 SAFE MOVEMENT AND ACCESS

OBJECTIVE

O2.5 The *Objective* is to-

- (a) provide people with safe access to and within a building; and
- (b) safeguard young children from drowning or injury in a *swimming pool*.

Application:

O2.5 only applies to a *swimming pool* with a depth of water more than 300 mm.

STATE AND TERRITORY VARIATIONS

1. O2.5(b) does not apply in New South Wales.

Note: Restriction of access to swimming pools in New South Wales is regulated under the Swimming Pools Act 1992.

2. O2.5(b) does not apply in the Northern Territory.

3. O2.5(b) does not apply in Queensland.

Note: Restriction of access to swimming pools in Queensland is regulated under the Building Act 1975.

4. O2.5(b) does not apply in Western Australia.

Note: Restriction of access to private swimming pools in Western Australia is regulated under the Local Government (Miscellaneous Provisions) Act 1960 and the Building Regulations 1989 as amended.

FUNCTIONAL STATEMENT

F2.5.1 Safety from falling

A building is to provide safe access for people to the services and facilities within.

F2.5.2 Swimming pool access

A *swimming pool* is to be provided with means to restrict access to it by young children.

Application:

F2.5.2 only applies to a *swimming pool* with a depth of water more than 300 mm.

Amdt 11

STATE AND TERRITORY VARIATIONS

1. **F2.5.2 does not apply in New South Wales.**

Note: Restriction of access to *swimming pools* in New South Wales is regulated under the Swimming Pools Act 1992.

2. **F2.5.2 does not apply in the Northern Territory.**

3. **F2.5.2 does not apply in Queensland.**

Note: Restriction of access to *swimming pools* in Queensland is regulated under the Building Act 1975.

4. **F2.5.2 does not apply in Western Australia.**

Note: Restriction of access to *swimming pools* in Western Australia is regulated under the Local Government (Miscellaneous Provisions) Act 1960 and the Building Regulations 1989 as amended.

Amdt 11

PERFORMANCE REQUIREMENT

P2.5.1 Stairways and ramps

So that people can move safely to and within a building-

- (a) walking surfaces must have safe gradients; and
- (b) any stairway or ramp must-

P2.5.1(b)(i)
Amdt No. 3

- (i) * * * * *

This clause has been deliberately left blank.

- (ii) have suitable landings to avoid undue fatigue of users; and
- (iii) be suitable for safe passage in relation to the nature, volume and frequency of likely usage; and
- (iv) have slip-resistant walking surfaces on ramps, and on stairway treads or near the edge of the nosing.

P2.5.2 Barriers

Where people could fall 1 m or more-

P2.5.2
Amdt No. 3

- (a) from a floor or roof of a building or through an opening (other than through an openable *window*) in the *external wall*; or
- (b) due to a sudden change of level within or associated with a building, a barrier must be provided which must be-
- (c) continuous and extend for the full extent of the hazard; and

- (d) of a height to protect people from accidentally falling from the floor or roof or through the opening; and
- (e) constructed to prevent people from falling through the barrier; and
- (c) capable of restricting the passage of children; and
- (d) of strength and rigidity to withstand-
 - (i) the foreseeable impact of people; and
 - (ii) where appropriate, the static pressure of people pressing against it.

P2.5.3 Swimming pool access

A barrier must be provided to a *swimming pool* and must-

- (a) be continuous for the full extent of the hazard; and
- (b) be of a strength and rigidity to withstand the foreseeable impact of people; and
- (c) restrict the access of young children to the pool and the immediate pool surrounds; and
- (d) have any gates and doors fitted with latching devices not readily operated by young children, and constructed to automatically close and latch.

Application:

P2.5.3 only applies to a *swimming pool* with a depth of water more than 300 mm.

STATE AND TERRITORY VARIATIONS

1. **P2.5.3 does not apply in New South Wales.**
Note: Restriction of access to *swimming pools* in New South Wales is regulated under the Swimming Pools Act 1992.
2. **P2.5.3 does not apply in the Northern Territory.**
3. **P2.5.3 does not apply in Queensland.**
Note: Restriction of access to *swimming pools* in Queensland is regulated under the Building Act 1975.
4. **P2.5.3 does not apply in Western Australia.**
Note: Restriction of access to *swimming pools* in Western Australia is regulated under the Local Government (Miscellaneous Provisions) Act 1960 and the Building Regulations 1989 as amended.

SECTION **3**

Amdt 11

ACCEPTABLE CONSTRUCTION

Introduction

The scope of these provisions

Suitability of Alternative Solutions

The use of maps

Consultation with appropriate authorities

Layout of Parts 3.1 - 3.11

How to use the requirements of each Part

SECTION 3 CONTENTS

	Page
SECTION 3 - ACCEPTABLE CONSTRUCTION	
How to Use	4,031
Introduction	
The scope of these provisions	
Suitability of Alternative Solutions	
The use of maps	
Consultation with appropriate authorities	
Layout of Parts 3.1 - 3.11	
How to use the requirements of each Part	
3.1 Site preparation	
3.1.1 Earthworks	5,021
3.1.1.0 Application	
3.1.1.1 Earthworks	
3.1.1.2 Excavation adjacent to vacant adjoining property	
3.1.1.3 Excavation adjacent to existing buildings	
3.1.1.4 Fill	
3.1.2 Drainage	5,201
3.1.2.0 Acceptable construction manual	
3.1.2.1 Application	
3.1.2.2 Drainage requirements	
3.1.2.3 Surface water drainage	
3.1.2.4 Subsoil drainage	
3.1.2.5 Stormwater drainage	
3.1.3 Termite risk management	5,501
3.1.3.0 Definitions	
3.1.3.1 Application of this Part	
3.1.3.2 Acceptable construction manual	
3.1.3.3 Application	
3.1.3.4 Installation of termite barriers	
3.1.3.5 Barriers for concrete slab-on-ground	
3.1.3.6 Barriers for suspended floors	
3.1.3.7 Attachments to buildings	
3.1.3.8 Explanatory information – Termites	
	Continued

Amdt 11

Continued		Page
3.2	Footings and slabs	7,021
3.2	Definitions	
3.2.0	Acceptable construction manuals	
3.2.1	Application	
3.2.2	Preparation	7,201
3.2.2.1	Excavation for footings	
3.2.2.2	Filling under concrete slabs	
3.2.2.3	Foundations for footings and slabs	
3.2.2.4	Slab edge support on sloping sites	
3.2.2.5	Stepped footings	
3.2.2.6	Vapour barriers	
3.2.2.7	Edge rebates	
3.2.3	Concrete and reinforcing	7,401
3.2.3.1	Concrete	
3.2.3.2	Steel reinforcement	
3.2.4	Site classification	7,601
3.2.4.1	Site classification	
3.2.5	Footing and slab construction	7,801
3.2.5.1	Footing and slab construction	
3.2.5.2	Footings and slabs to extensions to existing buildings	
3.2.5.3	Shrinkage control	
3.2.5.4	Minimum edge beam dimensions	
3.2.5.5	Footings for fireplaces on Class A and S sites	
3.2.5.6	Stump footing details	
3.3	Masonry	
3.3	Definitions	9,012
3.3.1	Unreinforced masonry	9,021
3.3.1.0	Acceptable construction manual	
3.3.1.1	Application	
3.3.1.2	External walls	
3.3.1.3	Internal walls	
3.3.1.4	Isolated piers	
3.3.1.5	Masonry units	
3.3.1.6	Mortar mixes	
		Continued

Continued	Page
3.3.1.7 Mortar joints	
3.3.1.8 Vertical articulation joints	
3.3.1.9 Sub-floor ventilation	
3.3.1.10 Shrinkage allowance for timber framing	
3.3.2 Reinforced masonry	9,301
3.3.2.0 Acceptable construction manual	
3.3.2.1 Application	
3.3.2.2 External wall construction	
3.3.3 Masonry accessories	9,601
3.3.3.0 Acceptable construction manual	
3.3.3.1 Application	
3.3.3.2 Wall ties	
3.3.3.3 Fixing straps and tie down systems	
3.3.3.4 Lintels	
3.3.4 Weatherproofing	9,801
3.3.4 Application of this Part	
3.3.4.0 Acceptable construction manual	
3.3.4.1 Application	
3.3.4.2 Width of cavity	
3.3.4.3 Cavity ventilation and drainage	
3.3.4.4 Damp-proof courses - materials	
3.3.4.5 Damp-proof courses - installation	
3.3.4.6 Flashings	
3.3.4.7 Location of flashings	
3.3.4.8 Flashings at the base of cavity walls	
3.3.4.9 Sill and head flashing	
3.3.4.10 Flashings at a roof abutting a wall	
3.3.4.11 Chimney flashings	
3.3.4.12 Weatherproofing for single skin masonry walls	
3.3.5 Earthwall construction	10,101
3.3.5 Definitions	
3.3.5.0 Acceptable construction manual	
3.3.5.1 Application	
3.3.5.2 General construction	
3.3.5.3 Minimum thickness of walls	
3.3.5.4 Weatherproofing	
	Continued

Amdt 11

Continued	Page
3.4 Framing	
3.4.0 Explanation of terms	11,051
3.4.1 Sub-floor ventilation	11,101
3.4.1.1 Application	
3.4.1.2 Sub-floor ventilation	
3.4.2 Steel framing	11,301
3.4.2.0 Acceptable construction manuals	
3.4.2.1 Application	
3.4.2.2 General	
3.4.2.3 Steel floor framing	
3.4.2.4 * * *	
3.4.2.5 * * *	
3.4.2.6 Installation of services	
3.4.3 Timber framing	11,601
3.4.3.0 Acceptable construction manuals	
3.4.3.1 * * *	
3.4.3.2 * * *	
3.4.3.3 * * *	
3.4.3.4 * * *	
3.4.3.5 * * *	
3.4.3.6 * * *	
3.4.3.7 * * *	
3.4.3.8 * * *	
3.4.4 Structural steel members	12,201
3.4.4 Explanation of terms	
3.4.4.0 Acceptable construction manuals	
3.4.4.1 Application	
3.4.4.2 Structural steel members	
3.4.4.3 Columns	
3.4.4.4 Corrosion protection	
3.5 Roof and wall cladding	
3.5.1 Roof cladding	13,021
3.5.1.0 Acceptable construction manuals	
3.5.1.1 Application	
3.5.1.2 Roof tiling	
3.5.1.3 Metal sheet roofing	
	Continued

Continued	Page
3.5.2 Gutters and downpipes	13,301
3.5.2.0 Acceptable construction manual	
3.5.2.1 Application	
3.5.2.2 Materials	
3.5.2.3 Selection of guttering	
3.5.2.4 Installation of gutters	
3.5.2.5 Downpipes - size and installation	
3.5.3 Wall cladding	13,501
3.5.3.1 Application	
3.5.3.2 Timber weatherboard cladding	
3.5.3.3 Fibre cement planks and weatherboard cladding	
3.5.3.4 Sheet wall cladding	
3.5.3.5 Eaves and soffit linings	
3.5.3.6 Flashings to wall openings	
3.6 Glazing	15,021
3.6 Definitions	
3.6.0 Acceptable construction manual	
3.6.1 Application	
3.6.2 Glazing sizes and installation	
3.6.3 Perimeter framed glazing	
3.6.4 Human impact safety requirements	
3.6.5 Doors	
3.6.6 Side panels	
3.6.7 Full height framed glazed panels	
3.6.8 Glazed panels, other than doors or side panels, on the perimeter of rooms	
3.6.9 Shower doors, shower screens and bath enclosures	
3.7 Fire safety	
3.7.1 Fire separation	17,021
3.7.1.1 Application	
3.7.1.2 General concession - non-combustible materials	
3.7.1.3 External walls of Class 1 buildings	
3.7.1.4 Measurement of distances	
3.7.1.5 Construction of external walls	
3.7.1.6 Class 10a buildings	
3.7.1.7 Allowable encroachments	
3.7.1.8 Separating walls	
	Continued

Continued	Page
3.7.1.9 Sarking type materials	
3.7.1.10 Roof lights	
3.7.2 Smoke alarms	17,301
3.7.2.1 Application	
3.7.2.2 Requirements for smoke alarms	
3.7.2.3 Location - Class 1a buildings	
3.7.2.4 Location - Class 1b buildings	
3.7.2.5 Lighting to assist evacuation - Class 1b buildings	
Explanatory information - Smoke alarms	
3.7.3 Heating appliances	17,501
3.7.3.0 Acceptable construction manuals	
3.7.3.1 Application	
3.7.3.2 Open fireplace construction	
3.7.3.3 Chimney construction	
3.7.3.4 Installation of insert fireplaces and flues	
3.7.3.5 Installation of free standing heating appliances	
3.7.4 Bushfire areas	17,701
3.7.4.0 Acceptable construction manuals	
3.7.4.1 Application	
3.7.4.2 Categories of bushfire attack	
3.7.4.3 Construction requirements	
3.7.5 Alpine areas	17,901
3.7.5.1 Application	
3.7.5.2 External doorways	
3.7.5.3 External ramps	
3.7.5.4 Discharge of external doorways providing a means of egress	
3.7.5.5 External trafficable structures	
3.8 Health and amenity	
3.8.1 Wet areas	19,021
3.8.1 Definitions	
3.8.1.0 Acceptable construction manual	
3.8.1.1 Application	
3.8.1.2 Wet areas	
3.8.1.3 Materials - general	
3.8.1.4 Protection of shower floors in wet areas	
	Continued

Amdt 11

Continued	Page
3.8.1.5 Protection of walls in wet areas	
3.8.1.6 Sealing of wall and floor junctions and joints	
3.8.2 Room heights	19,301
3.8.2.1 Application	
3.8.2.2 Ceiling heights	
3.8.3 Facilities	19,501
3.8.3.1 Application	
3.8.3.2 Required facilities	
3.8.3.3 Construction of sanitary compartments	
3.8.4 Light	19,701
3.8.4.1 Application	
3.8.4.2 Natural lighting	
3.8.4.3 Artificial lighting	
3.8.5 Ventilation	19,901
3.8.5.0 Acceptable construction manual	
3.8.5.1 Application	
3.8.5.2 Ventilation requirements	
3.8.5.3 Location of sanitary compartments	
3.8.6 Sound insulation	20,101
3.8.6.1 Application	
3.8.6.2 Sound insulation requirements	
3.8.6.3 General installation requirements for walls	
3.8.6.4 Soil and waste pipes	
3.9 Safe movement and access	
3.9.1 Stair construction	21,021
3.9.1 Definitions	
3.9.1.1 Application	
3.9.1.2 General requirements	
3.9.1.3 Stair construction	
3.9.1.4 Riser and going dimensions	
3.9.1.5 * * * * *	
3.9.2 Balustrades	21,201
3.9.2.1 Application	
3.9.2.2 When balustrades or other barriers are required	
3.9.2.3 Balustrade or other barrier construction	
	Continued

Amdt 11

Continued	Page
3.9.3 Swimming pool access	21,401
3.9.3.0 Acceptable construction manual	
3.9.3.1 Application	
3.9.3.2 Safety fencing location	
3.9.3.3 Safety fencing construction	
3.9.3.4 Gates and fittings	
3.10 Additional construction requirements	
3.10.1 High wind areas	23,021
3.10.1.0 Acceptable construction manuals	
3.10.2 Earthquake areas	23,201
3.10.2 Definitions	
3.10.2.0 Acceptable construction manual	
3.10.2.1 Application	
3.10.2.2 Construction requirements	
3.10.2.3 Construction for areas with an acceleration coefficient of 0.12 or more but less than 0.15	
3.10.2.4 Construction for areas with an acceleration coefficient of 0.15 or more	
3.11 Structural design manuals	
3.11 Acceptable construction manuals	25,021
3.11.1 Application	
3.11.2 Acceptable structural design manuals	
3.11.3 Loading requirements	
3.11.4 Structural design manuals	

PART 3.0 HOW TO USE SECTION 3

Explanatory information:

This is a non mandatory guide on how to use Section 3 of the *Housing Provisions*.

3.1 Introduction

Section 3, Parts 3.1-3.11 are *Deemed-to-Satisfy Provisions* that are considered to be acceptable forms of construction that meet the legislative requirements for complying with the *Housing Provisions* (ie they comply with the *Performance Requirements* listed in Section 2 of the *Housing Provisions*).

There is no obligation to adopt any particular option contained in Section 3 of the *Housing Provisions*, if it is preferred to meet the *Performance Requirement* in some other way.

However, if one of the options described in Section 3 is not complied with, then the *appropriate authority* must be satisfied that the *Performance Requirements* have been met.

3.2 The scope of these provisions

The *Deemed-to-Satisfy Provisions* (described as "acceptable construction practice" or "acceptable construction manuals") are indicative of some of the most common forms of national construction practice.

However, it should be noted that some of these options described as "acceptable construction practice" may have very specific limitations and accordingly will not be suitable for all applications. Generally these limitations relate to climatic (*design wind speed*), geographical and topographical conditions and building geometry.

If the acceptable construction practice option is not suitable for the proposed construction or *site* conditions, an alternative approach may be found in one of the acceptable construction manuals listed at the start of each Part. Similarly, if a particular building element or component *required* to comply with the *Housing Provisions* is not contained in the acceptable construction practice, reference will need to be made to the appropriate acceptable construction manual or Part 3.11.

3.3 Suitability of Alternative Solutions

The options described in Section 3 are typical examples. They are certainly not the only means available of complying with the *Housing Provisions*. The performance nature of this document provides flexibility and allows the use of alternative construction methods even though they may not be specifically described in an acceptable construction manual or as acceptable construction practice.

Alternative Solutions may be used provided they comply with the *Performance Requirements* listed in Section 2 (for further explanation see Part 1.0).

3.4 The use of maps

Maps have been used throughout Section 3 to indicate areas where particular requirements apply. These maps are indicative and some variation in conditions will apply, especially on the border of marked areas.

It is recommended that the *appropriate authority* be consulted and in most cases they may be able to identify what conditions apply in such areas at the early stage of building design.

3.5 Consultation with appropriate authorities

When building in certain locations there may be local conditions that may limit the type of construction that can be used. This is particularly important with *design wind speed* classifications and soil types.

Appropriate authorities have a wide range of experience and information on the geographical and topographical conditions found in their area of responsibility, and should be consulted during the initial design stage.

3.6 Layout of Parts 3.1- 3.11

Parts 3.1 - 3.11 of the *Housing Provisions* are organised in a manner that follows the logical construction sequence of a building. The following chart outlines some of the more frequently used details and where it is located in this document.

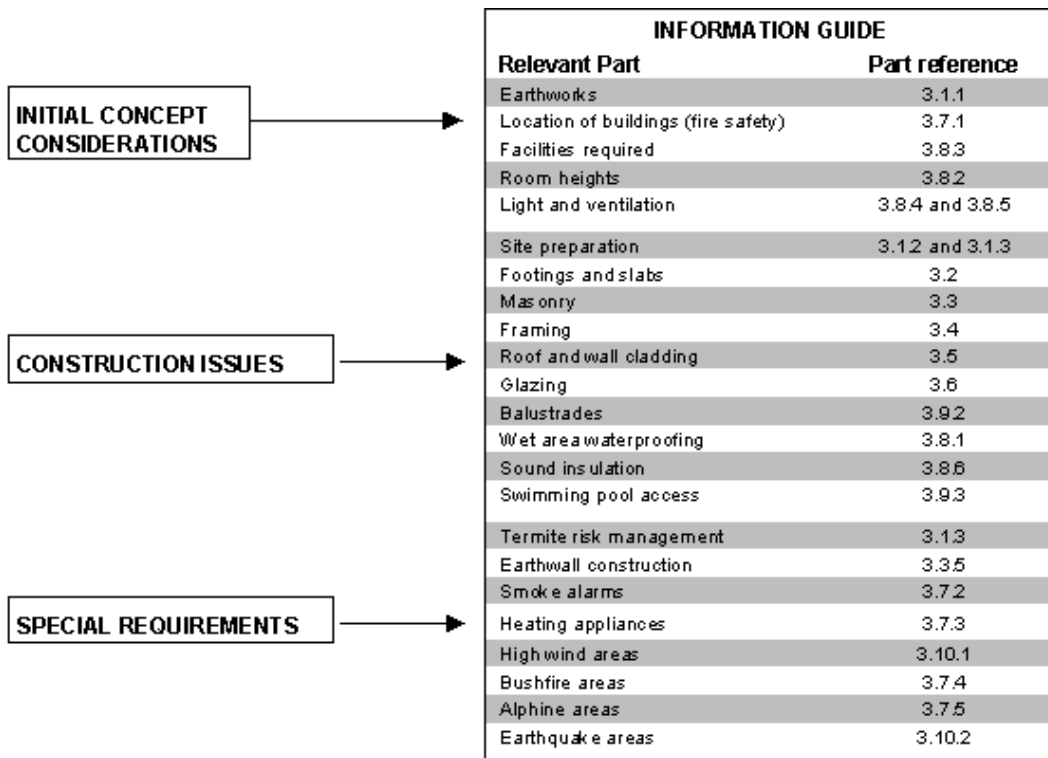

Amdt 11

3.7 How to use the requirements of each Part

The following is an example page layout from Part 3.2. This diagram explains the concepts behind typical clauses contained throughout Parts 3.1 to 3.11.

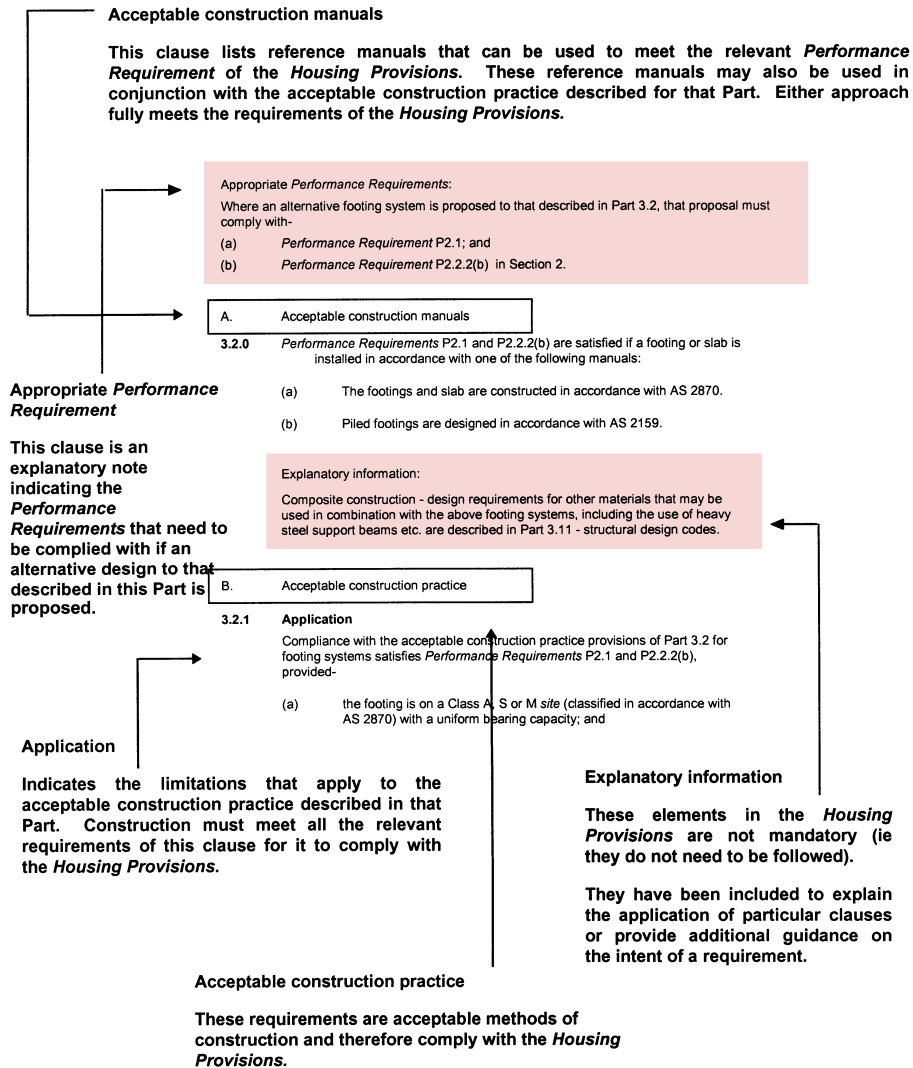

Amdt 11

PART **3.1**

Amdt 11

SITE PREPARATION

- 3.1.1 Earthworks**
- 3.1.2 Drainage**
- 3.1.3 Termite risk management**

PART 3.1 SITE PREPARATION

	Page
3.1.1 Earthworks	5,021
3.1.1.0 Application	
3.1.1.1 Earthworks	
3.1.1.2 Excavation adjacent to vacant adjoining property	
3.1.1.3 Excavation adjacent to existing buildings	
3.1.1.4 Fill	
3.1.2 Drainage	5,201
3.1.2.0 Acceptable construction manual	
3.1.2.1 Application	
3.1.2.2 Drainage requirements	
3.1.2.3 Surface water drainage	
3.1.2.4 Subsoil drainage	
3.1.2.5 Stormwater drainage	
3.1.3 Termite risk management	5,501
3.1.3 Application of this Part	
3.1.3.0 Acceptable construction manual	
3.1.3.1 Application	
3.1.3.2 Installation of termite barriers	
3.1.3.3 Barriers for concrete slab-on-ground	
3.1.3.4 Barriers for suspended floors	
3.1.3.5 Attachments to buildings	
Explanatory information - Termites	

Amdt 11

Explanatory information:

These provisions relate to general *site* preparation for footings, services, drainage and installation of termite barriers to assist in termite management.

It should be noted that other construction methods may be used to achieve the same results as specified in this Part provided they comply with the appropriate *Performance Requirement*.

PART 3.1.1 EARTHWORKS

Appropriate Performance Requirements:

Where an alternative approach to earthworks is proposed to that described in Part 3.1.1, that proposal must comply with the *Performance Requirement P2.1* in Section 2.

NSW var.
Amdt No. 11

STATE AND TERRITORY VARIATIONS

Except for Table 3.1.1.1 as referenced by Figures 3.1.2.1 and 3.1.2.2 and except for clause 3.1.1.0 (b) for determination of a normal site as referenced by clause 3.2.1, Part 3.1.1 does not apply in New South Wales.

Note: In New South Wales the consent authority can determine to place controls on siteworks associated with the erection of a building, by imposing conditions when it grants development consent. These controls can include the safeguarding of excavations and backfilling, provision of retaining walls to prevent soil movement, and support for neighbouring buildings. Information addressing siteworks can be found in the Department of Planning's Act and Regulation note "Health, safety and amenity during construction."

Amdt 11

Acceptable construction practice

3.1.1.0 Application

Compliance with this Part satisfies *Performance Requirement P2.1* for earthworks provided:

- (a) The work is undertaken in normal *site* conditions.
- (b) For the purposes of this Part, normal *site* conditions are defined by the following parameters-
 - (i) a *site* that is classified as A, S, M, H or E in accordance with Part 3.2; and
 - (ii) moisture conditions on *site* are as a result of seasonal and climatic changes; and
 - (iii) the *site* is not subject to unusual moisture conditions caused by drains, dams, channels, ponds or tanks which are maintained or removed from the *site*; and
 - (iv) large trees have not been recently removed from the *site*; and
 - (v) soil moisture conditions have not been significantly modified by the removal of buildings or other structures; and
 - (vi) drainage on the allotment is maintained.

Explanatory information:

The provisions described in Part 3.1.1 will enable earthworks to be carried out safely and avoid potential damage to adjoining structures and property through the soil collapsing or subsiding during building works. Exceptional *site* conditions (including the effects of torrential rain) may need special consideration and additional advice from appropriately qualified people should be considered.

State and Territory legislation may also have requirements that affect the excavation, especially in relation to adjoining property and notification to owners of that property. Advice should be obtained from the *appropriate authority* before commencement of works.

3.1.1.1 Earthworks

Excavation and fill utilising unprotected embankments can be undertaken in accordance with-

- (a) Table 3.1.1.1 for general earthwork; or
- (b) 3.1.1.2 for excavation adjacent to vacant adjoining property; or
- (c) 3.1.1.3 for excavation adjacent to existing buildings; or
- (d) 3.1.1.4 for fill adjacent to adjoining property.

3.1.1.2 Excavation adjacent to vacant adjoining property

Excavation work, using unprotected embankments, adjacent to another allotment can be undertaken provided-

- (a) there are no buildings or structures on the adjoining allotment within 3 m of the allotment boundary adjacent to the excavation; and
- (b) the excavation commences at the allotment boundary and is within the area defined as being suitable for excavation in Figure 3.1.1.1; and
- (c) the slope of the unprotected embankment of the excavation complies with the appropriate soil classification slope described in Table 3.1.1.1.

3.1.1.3 Excavation adjacent to existing buildings

Excavation work for footings, drainage trenches or other similar works, adjacent to existing buildings can be undertaken provided-

- (a) the angle to determine the safe area for excavation is taken from the bottom of the shallowest point of the existing footing in accordance with Figure 3.1.1.2; and
- (b) the excavation is within the area defined as being suitable for excavation in Figure 3.1.1.2; and
- (c) the slope of the unprotected embankment of the excavation complies with the appropriate soil classification described in Table 3.1.1.1; and
- (d) for footing excavation adjacent to existing footings -

- (i) the footing is placed as soon as practicable after exposing the existing footing; and
- (ii) the existing footing, where on an adjoining property, is completely isolated from the new footing by means of a flexible bond breaker not less than 10 mm thick; and
- (e) the adjoining footing is not left exposed at the completion of works.

Figure 3.1.1.1
EXCAVATION AFFECTING ADJOINING PROPERTY

Note: The angle for line A-A is defined in Table 3.1.1.1.

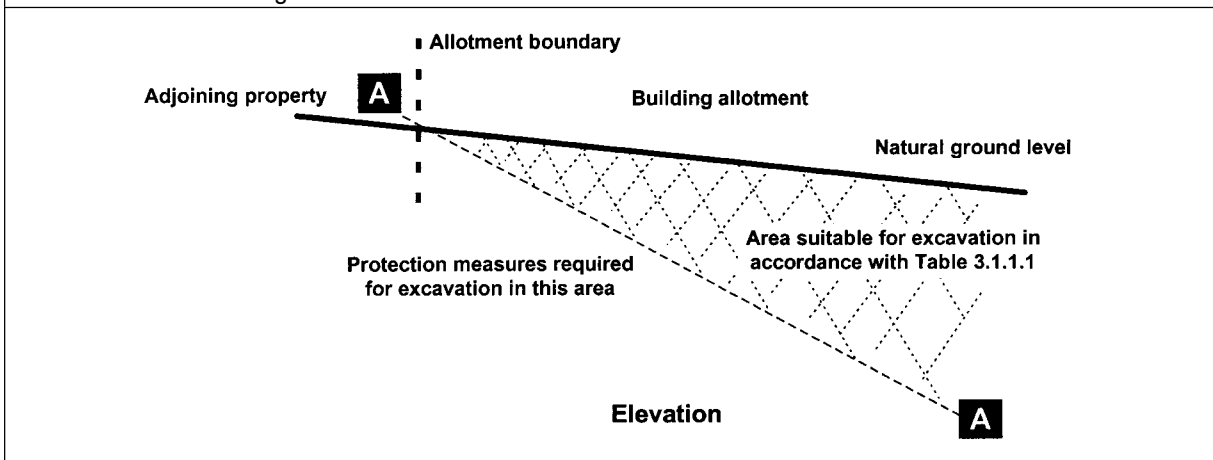
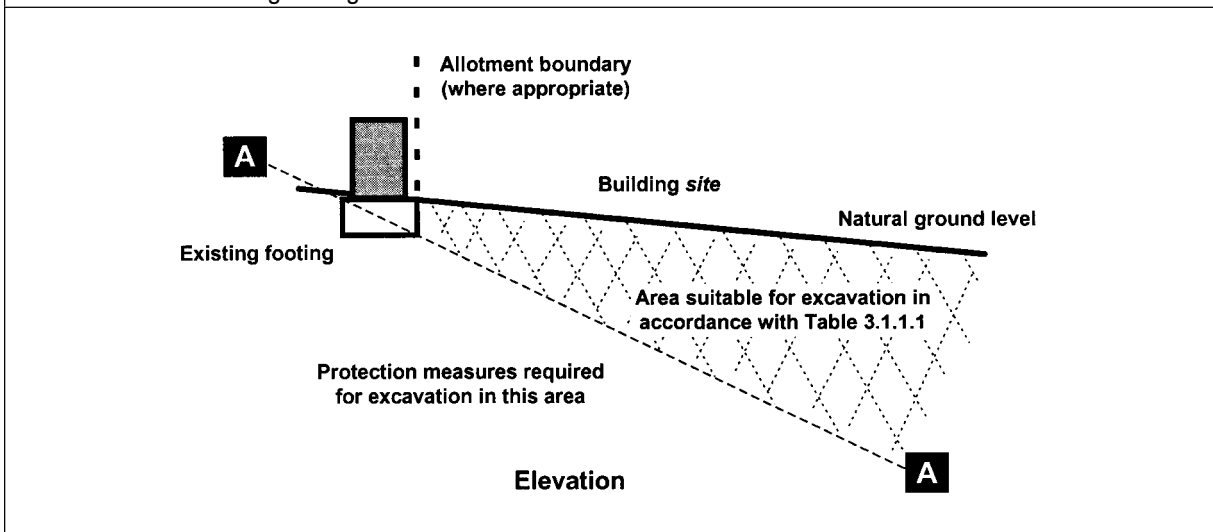

Figure 3.1.1.2
EXCAVATION ADJACENT TO EXISTING BUILDINGS

Note: Line A-A is defined in Table 3.1.1.1 and taken from the bottom of the shallowest point of the existing footing.



Amdt 11

3.1.1.4 Fill

Filling works may be carried out provided-

- (a) where the fill is deeper than existing soil level, the gradient of the fill complies with Table 3.1.1.1; and
- (b) where the fill is to be used to support footings or slabs, it is placed and compacted in accordance with Part 3.2.

Table 3.1.1.1
Amdt No. 7

SOIL TYPE (*see Part 3.2.4 for material description)		EMBANKMENT SLOPES H:L	
		Compacted fill (see Part 3.2)	Cut
Stable rock (A*)		2:3	8:1
Sand (A*)		1:2	1:2
Silt (P*)		1:4	1:4
Clay	Firm clay	1:2	1:1
	Soft clay	Not suitable	2:3
Soft soils (P*)		Not suitable	Not suitable

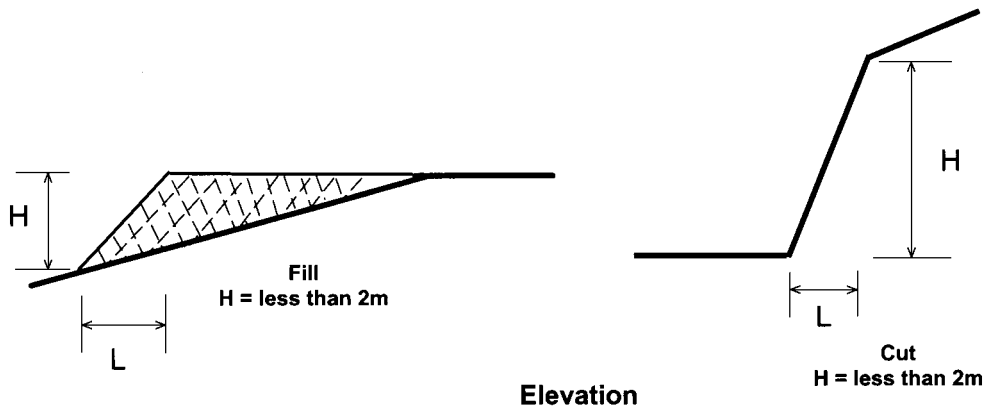

Amdt 11

PART 3.1.2 DRAINAGE

Appropriate *Performance Requirements*:

Where an alternative drainage system is proposed to that described in Part 3.1.2, that proposal must comply with *Performance Requirement P2.2.1* in Section 2.

A. Acceptable construction manual

3.1.2.0 *Performance Requirement P2.2.1* is satisfied for drainage if the drainage is designed and constructed in accordance with AS/NZS 3500.3.2 - Stormwater drainage, or AS/NZS 3500.5 – Domestic installations, Section 5 – Stormwater drainage.

3.1.2.0
Amdt No. 8

B. Acceptable construction practice

3.1.2.1 Application

3.1.2.1
Amdt No. 8

Compliance with this Part satisfies *Performance Requirement P2.2.1* for drainage of-

- (a) roofs in areas subject to 5 minute duration rainfall intensities of not more than 255 mm per hour over an *average recurrence interval* of 20 years (as per Table 3.5.2.1) where a drainage system is *required*; and
- (b) sub-soil areas where excessive soil moisture problems may occur; and
- (c) land adjoining and under buildings,

provided the stormwater drainage system otherwise complies with AS/NZS 3500.3.2 or Section 5 of AS/NZS 3500.5.

Amdt 11

Explanatory information:

1. The BCA does not require the installation of drainage systems. Accordingly these requirements need only be applied when these systems are used.
2. Information on the need for drainage systems may be obtained from the *appropriate authority*.
3. The legal discharge point from a building *site* is generally determined by local government authorities.

3.1.2.2 Drainage requirements

Drainage systems must be installed as follows-

- (a) areas adjoining and under buildings - *surface water* drainage in accordance with 3.1.2.3; and
- (b) where *site* conditions exist that create a need for subsoil water to be diverted away from footings, basements, retaining walls etc - sub-soil drainage in accordance with 3.1.2.4; and
- (c) where underground drainage from roof areas is *required* or permitted - underground stormwater drainage in accordance with 3.1.2.5; and
- (d) excavation for drains adjacent to existing footings must be within the area described in Figure 3.1.2.1 as being safe for excavation.

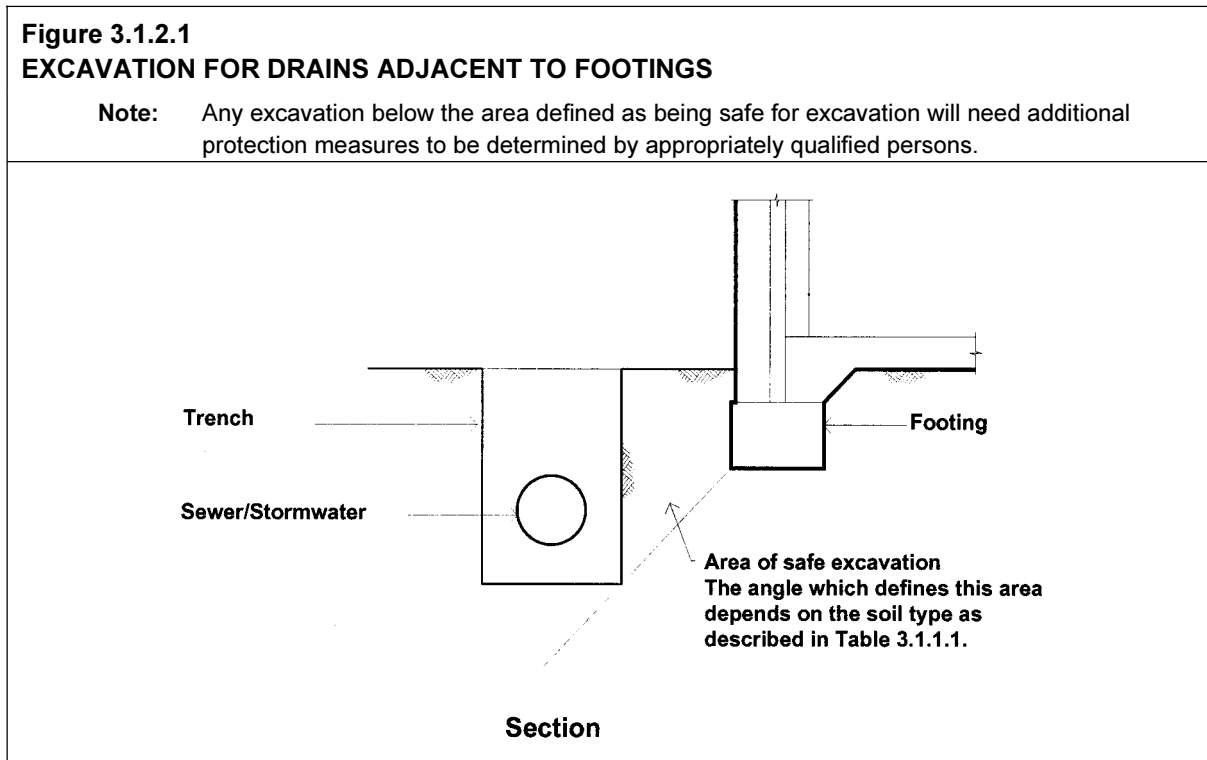

3.1.2.3 Surface water drainage

Surface water must be diverted away from Class 1 buildings as follows:

- (a) Slab-on-ground - finished ground level adjacent to buildings

The external finished surface surrounding the slab must be drained to move *surface water* away from the building and graded to give a slope of not less than 50 mm over the first 1m from the building (see Figure 3.1.2.2).

- (b) Slab-on-ground - finished slab heights

The height of the slab-on-ground (measured at the slab edge) above external finished surfaces must be not less than-

- (i) 150 mm above finished ground level; or
- (ii) 100 mm above sandy, well-drained areas; or
- (iii) 50 mm above paved or concreted areas that slope away from the building in accordance with (a).

Explanatory information:

The appropriate slab height above finished ground level may vary depending on:

1. The local plumbing requirements; in particular the height of the overflow relief gully relative to drainage fittings and ground level (to work effectively they must be a minimum of 150 mm below the lowest sanitary fixture).
2. The run-off from storms and the local topography.
3. The effect of excavation on a cut and fill *site*.
4. The possibility of flooding.
5. Termite barrier provisions.

- (c) The ground beneath suspended floors must be graded so that the area beneath the building is above the adjacent external finished ground level and *surface water* is prevented from ponding under the building (see Figure 3.1.2.3).

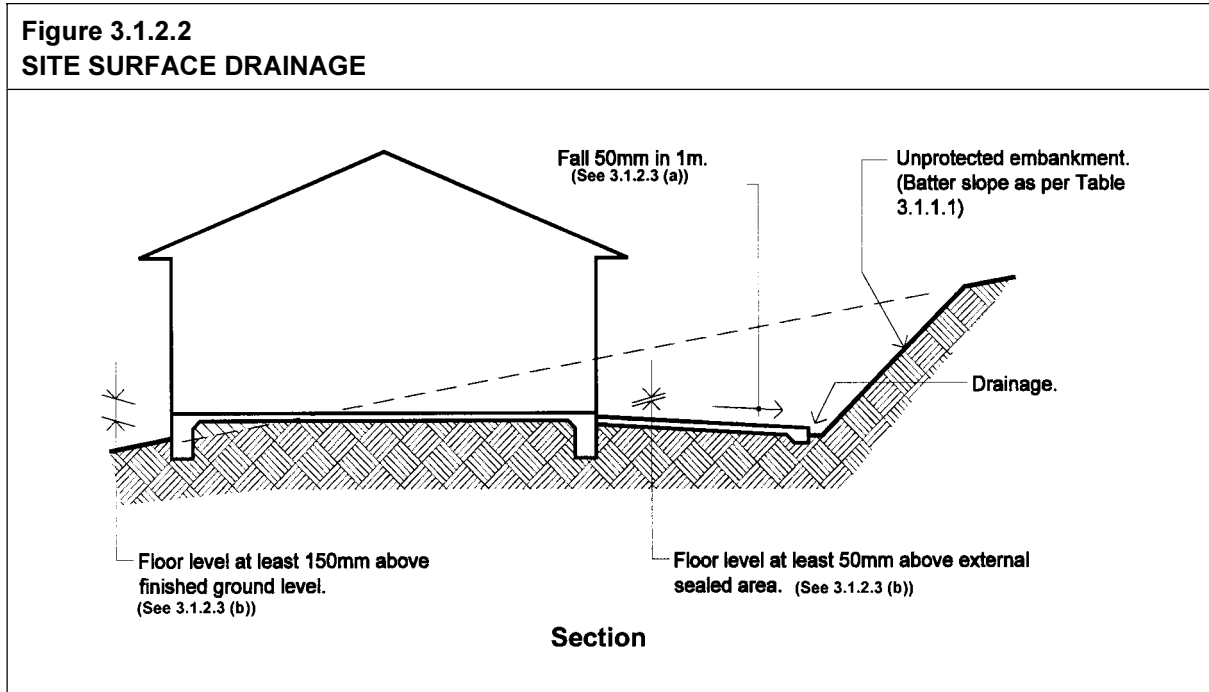

Amdt 11

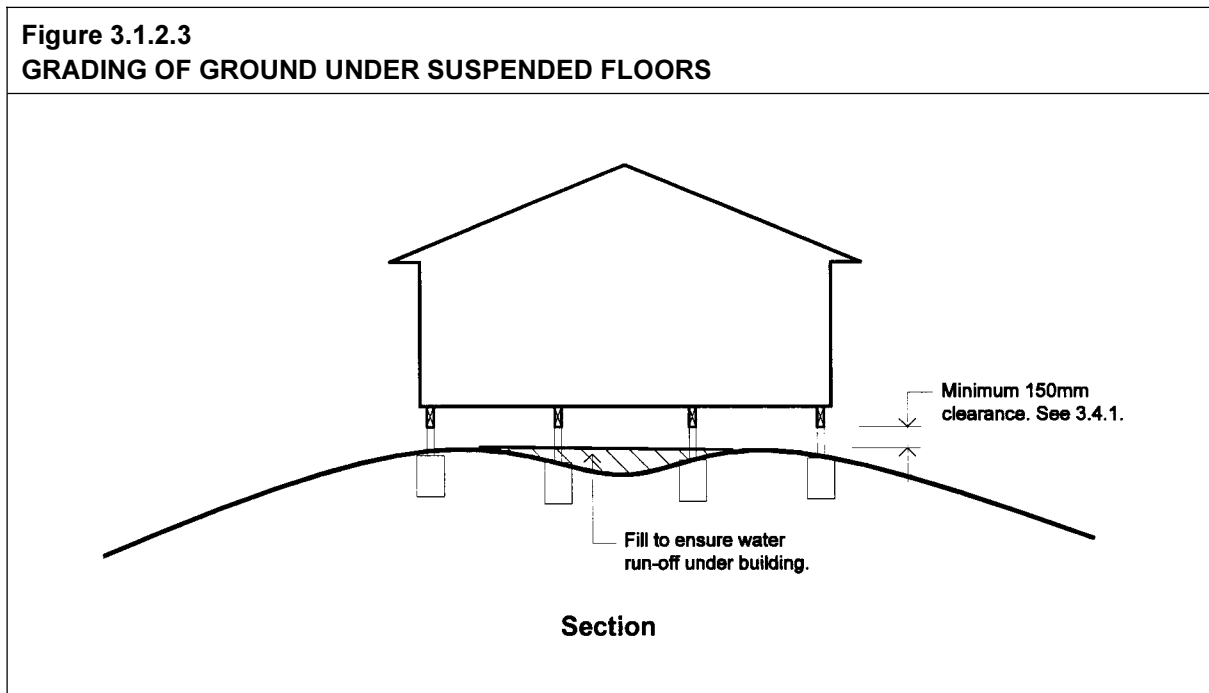

3.1.2.4 Subsoil drainage

Where a subsoil drainage system is installed to divert sub-surface water away from the area beneath the building it must comply with the following:

Explanatory information:

Subsoil drainage may need to be installed where subsoil water movement could damage buildings through the build up of excessive moisture or lateral water pressure on footings.

- (a) The depth to the top of the drain must not be less than 400 mm into the soil; and not less than 100 mm below any adjacent-
 - (i) pavement level; and
 - (ii) footing base.
- (b) Trench bases (as appropriate) must be graded to a uniform fall to suit the following-
 - (i) parallel with pavement grade; and
 - (ii) parallel with overall grade of footings; and
 - (iii) not less than 1:300.
- (c) The bottom of the trench must be well compacted and evenly graded.
- (d) The drain must be laid true to line and gradient on the bottom of the trench or where rock is encountered, on compacted bedding.
- (e) Silt pits or sumps of a suitable size for expected water flow, must be provided at the outlet end of each subsoil drain before it discharges into an impervious drainage line.

Explanatory information:

Silt pits designed to control the amount of silt entering the drainage system are usually installed where the excavation on a *site* exceeds 1 m and there is a need to drain subsoil water movement.

Silt pits are typically prefabricated and designed to suit a range of conditions. Heavy duty silt pits are not commonly used in domestic applications except in areas subject to traffic (such as where a driveway runs down towards a garage located under a dwelling).

To be effective the silt pit must be maintained by regular cleaning.

- (f) Outlets must be installed through walls of silt pits not less than 50 mm below the lowest point of the inlet (see Figure 3.1.2.4).

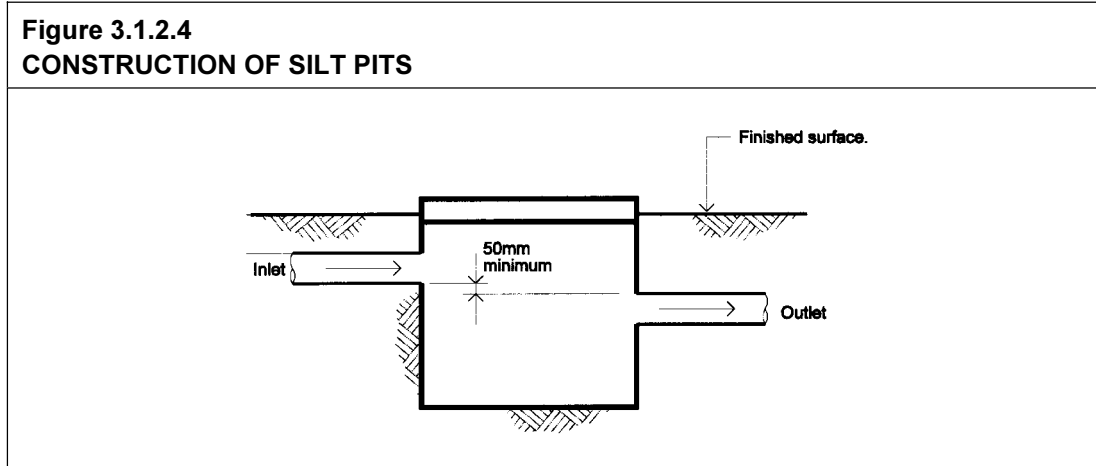

Amdt 11

- (g) Drainage trenches in clay soils using sand filters must be constructed in accordance with Figure 3.1.2.5.

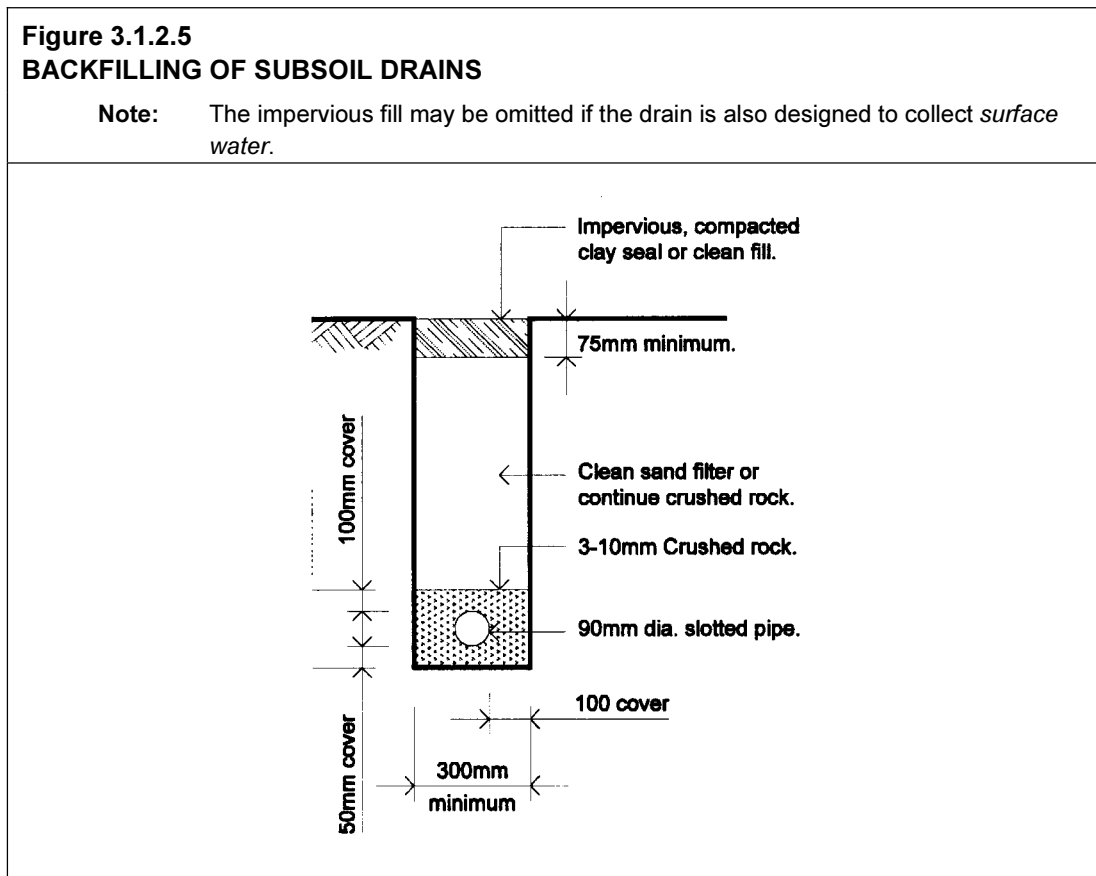

Explanatory information:

The design of alternative subsoil drains will need to consider the nature of the soil and the anticipated water level and movement. One of the main concerns with subsoil drains is to keep fine soil particles from clogging the soil filters and accordingly preventing free water movement.

The following are various configurations for subsoil drains using geotextile filters and different pipe configurations. Drainage may be achieved by trenches filled with filter material or enhanced using pipes such as slotted UPVC or geotextile wrapped PVC.

Subsoil drains may also be required on the uphill side of cut and fill *sites*; adjacent deep strip footings, behind retaining walls, adjacent to basement walls etc in soil with poor drainage qualities or excessive sub-water movement.

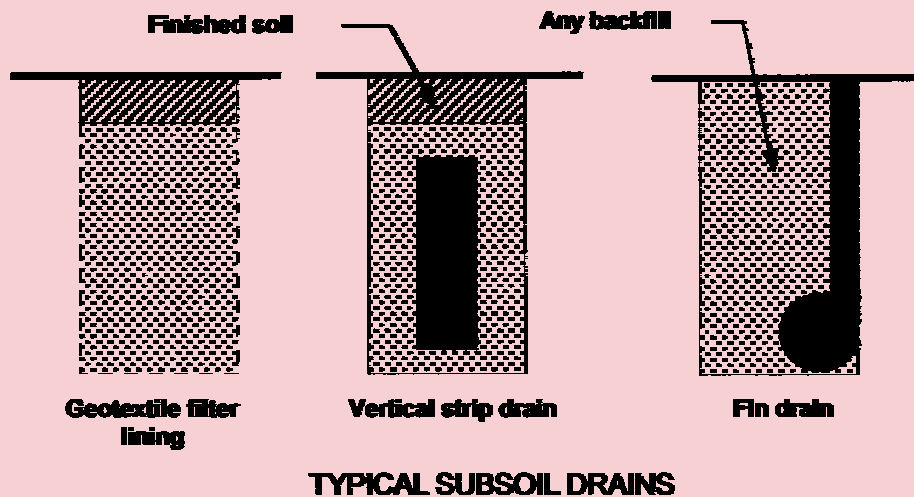
**3.1.2.5 Stormwater drainage**

Where a stormwater drainage system is installed, it must comply with the following:

- (a) The position and manner of discharge of the stormwater drainage system must be to the satisfaction of the *appropriate authority*.
- (b) The stormwater drainage system must be designed so that any overflow during heavy rain periods is prevented from flowing back into the building.

Explanatory information:

The manner of discharge of stormwater drainage systems includes consideration of discharge points. Some examples of discharge points which may be acceptable to the *appropriate authority* are:

- (a) A legal discharge point at the allotment boundary.
- (b) On-site catchment systems, such as stormwater tanks.
- (c) On-site soil drainage systems, such as soaker wells.

Explanatory information:

Stormwater drainage systems specified in the *Housing Provisions* are not designed to remove all of the water during exceptionally heavy rain, especially in tropical areas. Accordingly, it is necessary to design and install the system so that when overflowing occurs any water is directed away from the inside of the building and away from the building *foundation*.

To ensure that roof gutters do not overflow into the building consideration should be given to using slotted gutters, locating the gutter so that it is below the top edge of the fascia, the installation of rainwater heads with overflow slots etc.

Special attention needs to be given to box gutters, valley gutters etc located above the internal areas of a building. In these situations if adequate overflow controls cannot be implemented there may be a need to increase the size and capacity of drainage components to remove all water anticipated during heavy rain periods.

3.1.2.5(c)
Amdt No. 2

(c) Cover to stormwater drains

The cover to 90 mm Class 6 UPVC stormwater drains installed underground must be not less than-

- (i) under soil - 100 mm; or
- (ii) under paved or concrete areas - 50 mm; or
- (iii) under areas subject to light vehicle traffic-
 - (A) reinforced concrete - 75 mm; or
 - (B) paved - 100 mm.

Explanatory information:

Different depths of soil cover (or no cover at all) can be achieved using other types of pipes. The cover specified is measured from the top of the pipe to either the finished ground level or, in the case of paved or concreted areas, to the underside of the paving or concrete.

PART 3.1.3 TERMITE RISK MANAGEMENT

Definitions

3.1 The following definitions are used in this Part:

3.1
Amdt No. 3

Primary building element means a member of a building designed specifically to take part of the building loads and includes roof, ceiling, floor, stairway or ramp and wall framing members including bracing members designed for the specific purpose of acting as a brace to those members.

Expl. Info
Amdt No. 11

Explanatory information:

The loads to which a building may be subjected are dead, live, wind, snow and earthquake loads. Further information on building loads can be found in AS/NZS 1170.1.

Qld var.
Amdt No. 8

STATE AND TERRITORY VARIATIONS

In Queensland delete definition of primary building element and replace with the following:

Primary building element means-

- (a) a member of a building designed specially to take part of the building loads and includes roof, ceiling, floor, stairway or ramp and wall framing members including bracing members designed for the specific purpose of acting as a brace to those members; and
- (b) door jambs, window frames and reveals, architraves and skirtings.

3.1.3 Application

- (a) The requirements of this Part apply when a *primary building element* of a Class 1 and 10 building is considered susceptible to termite attack.
- (b) This Part does not apply to Class 1 and 10 buildings as follows (see also Figure 3.1.3.1):
 - (i) Buildings in areas where subterranean termites are not known to present a potential risk of attack to the *primary building elements* of the building.

Expl. Info
Amdt No. 9

Explanatory information:

Termites are not considered to be a risk in Tasmania and a lesser risk in parts of Victoria. The *appropriate authority* may have records of termite activity for each area and may be able to advise you on whether termite risk management is needed.

Amdt 11

3.1.3(b)(ii)
Amdt No. 9

- (ii) Buildings that have all their *primary building elements* constructed of one, or a combination of, the following materials:
- (A) Steel, aluminium or other metals.
 - (B) Concrete.
 - (C) Masonry.
 - (D) Fibre-reinforced cement.
 - (E) Naturally termite resistant timber in accordance with Appendix C of AS 3660.1.
 - (F) Preservative treated timber in accordance with Appendix D of AS 3660.1.
- (iii) Buildings in Tasmania.

Expl. Info
Amdt No. 4**Explanatory information:**

Where individual *primary building elements* are susceptible to termite attack and the remainder of the *primary building elements* are constructed of termite resistant materials, only the susceptible elements need to be provided with a termite barrier.

NT var.
Amdt No. 8**STATE AND TERRITORY VARIATIONS****3.1.3(b)(ii)(E) is replaced by the following clause in the Northern Territory**

(E) Naturally termite resistant timber in accordance with Appendix C of AS 3660.1 in areas where *Mastotermes darwiniensis* are not prevalent.

Amdt 11

Fig 3.1.3.1
Amdt No. 9

Figure 3.1.3.1
FLOW CHART FOR IDENTIFYING IF A TERMITE BARRIER IS REQUIRED

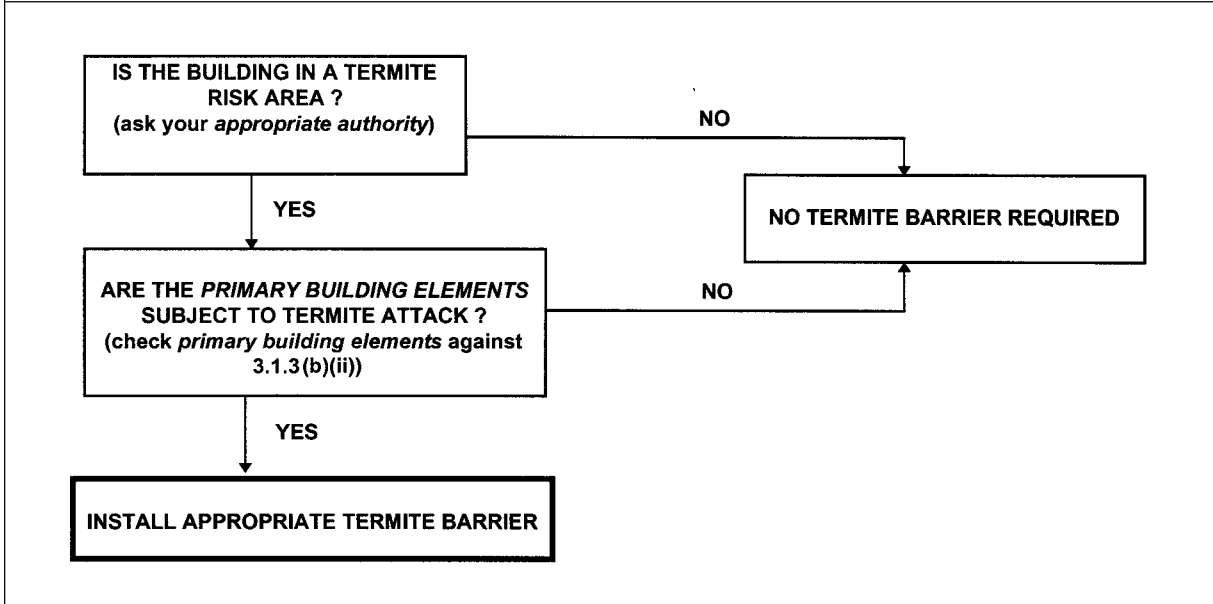

Amdt 11

Appropriate Performance Requirements:

Where an alternative termite barrier or system is proposed to that described in Part 3.1.3, that proposal must comply with *Performance Requirement P2.1* in Section 2.

A. Acceptable construction manual

3.1.3.0 Acceptable construction manual

Performance Requirement P2.1 is satisfied for termite risk management if-

3.1.3.0(a)
Amdt No. 9

- (a) a termite barrier is installed in a Class 1 or 10 building to minimise the risk of termite attack to *primary building elements* in accordance with AS 3660.1 – Termite management – New building work; and
- (b) a durable notice is installed in accordance with 3.1.3.2(b).

STATE AND TERRITORY VARIATIONS

NT var.
Amdt No. 2

In the Northern Territory delete 3.1.3.0(b) and insert 3.1.3.0(b) and (c) as follows:

- (b) a durable notice is installed in accordance with 3.1.3.2(b); and
- (c) additional termite risk management measures are used in areas where *Mastotermes darwiniensis* are prevalent.

STATE AND TERRITORY VARIATIONS

Qld var.
Amdt No. 9**In Queensland delete 3.1.3.0 and replace with the following:****3.1.3.0 Acceptable construction manual**

Performance Requirements P2.1 and P2.1.1 are satisfied for termite risk management if-

- (a) a termite barrier is installed in a Class 1 or 10 building to minimise the risk of termite attack to *primary building elements* in accordance with AS 3660.1 – Termite management – New building work, except that in regard to Clause 8.8.2, and Clause 8.8.3 where access for visual inspection in accordance with 3.7.2 is not possible, a hand sprayed chemical barrier must not be used; and
- (b) where a chemical barrier is used to protect the external perimeter of the building, the barrier must be-
 - (i) installed by excavating trenches, treating the exposed trench and backfilling the trench with treated material; and
 - (ii) protected by a 50 mm thick concrete cover strip not less than 300 mm wide measured from the external wall of the building; and
- (c) durable notices are installed in accordance with 3.1.3.2(b).

Amdt 11

B. Acceptable construction practice**3.1.3.1 Application**

Compliance with this Part satisfies *Performance Requirement* P2.1 for termite risk management.

Explanatory information:

The intent of these requirements is to provide for a termite barrier that will ensure that termites will not enter a building by a concealed route. The installation of termite barriers will not stop termite activity from occurring on the site.

STATE AND TERRITORY VARIATIONS

NT var.
Amdt No. 2**3.1.3.1 is replaced by the following clause in the Northern Territory.**

Compliance with this Part satisfies *Performance Requirement* P2.1 for termite risk management provided that additional termite risk measures are used in areas where *Mastotermes darwiniensis* are prevalent.

STATE AND TERRITORY VARIATIONS

Qld var.
Amdt No. 8**In Queensland delete 3.1.3.1 and replace with the following:****3.1.3.1 Application**

Compliance with this Part satisfies *Performance Requirements* P2.1 and P2.1.1 for termite risk management.

Amdt 11

3.1.3.2 Installation of termite barriers

- (a) A termite barrier or combination of barriers must be installed in accordance with-
- (i) AS 3660.1; or
 - (ii) 3.1.3.3 for concrete slabs on ground; or
 - (iii) 3.1.3.4 for suspended floors.
- (For barrier options see Table 3.1.3.1).

3.1.3.2
Amdt No. 9

- (b) A durable notice must be permanently fixed to the building in a prominent location, such as in a meter box or the like, indicating-
- (i) the method of termite risk management; and
 - (ii) the date of installation of the system; and
 - (iii) where a chemical barrier is used, its life expectancy as listed on the National Registration Authority label; and
 - (iv) the installer's or manufacturer's recommendations for the scope and frequency of future inspections for termite activity.

Explanatory information:**Durable notice**

A durable notice must be fixed to the building in a prominent location advising the building occupants that the system should be inspected and maintained.

The notice should be clearly written, on a material that will not deteriorate or fade over time and be located in or near the meter box or similar location so that it can be easily seen and read by future owners of the building. Additional information may be included if desired by the person placing the notice.

Qld var.
Amdt No. 9

STATE AND TERRITORY VARIATIONS

In Queensland delete 3.1.3.2 and replace with the following:

3.1.3.2 Installation of termite barriers

- (a) A termite barrier or combination of barriers must be installed in accordance with-
- (i) AS 3660.1 subject to Clause 3.1.3.0(a); or
 - (ii) 3.1.3.3 for concrete slabs on ground; and
 - (iii) 3.1.3.4 for suspended floors.
- (For barrier options, see Table 3.1.3.1)
- (b) At least 2 durable notices must be permanently fixed to the building in prominent locations, such as in a meter box and a kitchen cupboard or the like, indicating-
- (i) the method of termite risk management; and
 - (ii) the date of installation of the system; and
 - (iii) where a chemical barrier is used, its life expectancy as listed on the National Registration Authority label; and
 - (iv) the installer's or manufacturer's recommendations for the scope and frequency of future inspections for termite activity.

Explanatory information:

Durable notices

At least two durable notices must be fixed to the building in prominent locations advising the building occupants that the system should be inspected and maintained. The notices should be clearly written, on a material that will not deteriorate or fade over time and be located in or near the meter box and in a kitchen cupboard or similar location so that it can be easily seen and read by future owners of the building. Additional information may be included if desired by the person placing the notice.

Amdt 11

Table 3.1.3.1
Amdt No. 9

Table 3.1.3.1					
ACCEPTABLE TERMITE BARRIERS					
TERMITE MANAGEMENT SYSTEM (as per AS 3660.1)	FOOTING SYSTEM				
	Concrete slab on ground complying with AS 2870		Concrete slab on ground not complying with AS 2870		Suspended floors
	Penetrations and control joints	Slab perimeter	Beneath slab (includes penetrations and control joints)	Slab perimeter	
Slab edge exposure	Not suitable	Suitable	Not suitable	Suitable	Not applicable
Termite shielding	Not suitable	Not suitable	Not suitable	Not suitable	Suitable
Stainless steel mesh	Partial; or Full system	Partial; or Full system	Full system	Full system	Suitable
Graded stone	Partial; or Full system	Partial; or Full system	Full system	Full system	Partial; or Full system
Chemicals	Full system beneath slab	Perimeter system	Full system beneath slab	Perimeter system	Full system

Amdt 11

Explanatory information:

A “partial system” as referred to in Table 3.1.3.1 is one that when used in a combination with other systems, will form a “full system”. This is similar to 3.1.3.2 which refers to a “termite barrier or combination of barriers”.

For example, if a concrete slab is used as a barrier, it in itself will not provide a complete barrier to termites. Then, depending on the construction methods and the site conditions, additional requirements will be necessary for service penetrations. Each of these are “partial” treatment, yet when integrated, will form a “full system”.

In addition to the acceptable termite barriers described in Table 3.1.3.1, other methods or systems can be used if it can be demonstrated that they meet the relevant *Performance Requirements* of the *Housing Provisions*. Forms of evidence of suitability are described in Part 1.2 - Acceptance of design and construction.

Qld var.
Amdt No. 9

STATE AND TERRITORY VARIATIONS

In Queensland delete Table 3.1.3.1 and replace with the following:

Table 3.1.3.1 ACCEPTABLE TERMITE BARRIERS					
TERMITE MANAGEMENT SYSTEM (as per AS 3660.1)	FOOTING SYSTEM				
	Concrete slab on ground complying with AS 2870		Concrete slab on ground not complying with AS 2870		Suspended floors
	Penetrations and control joints	Slab perimeter	Beneath slab (includes penetrations and control joints)	Slab perimeter	
Slab edge exposure	Not suitable	Suitable	Not suitable	Suitable	Not applicable
Termite shielding	Not suitable	Not suitable	Not suitable	Not suitable	Suitable
Stainless steel mesh	Partial; or Full system	Partial; or Full system	Full system	Full system	Suitable
Graded stone	Partial; or Full system	Partial; or Full system	Full system	Full system	Partial; or Full system
Chemicals	Full system beneath slab subject to 3.1.3.0(a)	Perimeter system subject to 3.1.3.0(b)	Full system beneath slab subject to 3.1.3.0(a)	Perimeter system subject to 3.1.3.0(b)	Full system subject to 3.1.3.0(a)

Amdt 11

3.1.3.3 Barriers for concrete slab-on-ground

3.1.3.3
Amdt No. 9

- (a) Where a concrete slab-on-ground is to be used as part of a termite barrier system, the slab must be designed and constructed to comply with AS 2870, and-
- (i) monolithic slabs must have penetrations and the perimeter of the slab treated in accordance with Table 3.1.3.1 (see Figure 3.1.3.2); and
 - (ii) non-monolithic slabs must have penetrations, control joints and the perimeter of the slab treated in accordance with Table 3.1.3.1 (see Figure 3.1.3.3).
- (b) Slabs not constructed in accordance with AS 2870 must have the full area beneath the slab and the perimeter treated in accordance with Table 3.1.3.1.
- (c) The edge of a slab-on-ground may be used as a perimeter barrier provided-
- (i) the slab edge is left exposed, not less than 75 mm above finished ground level; and
 - (ii) the face of the exposed edge is not rough or honeycombed and does not contain ripples caused by folds in vapour barrier or the like that could conceal termite activity; and
 - (iii) the exposed surface is not rendered, tiled, clad or concealed by *flashing*.

Amdt 11

Figure 3.1.3.2
AREAS TO BE TREATED FOR CONCRETE SLAB ON GROUND

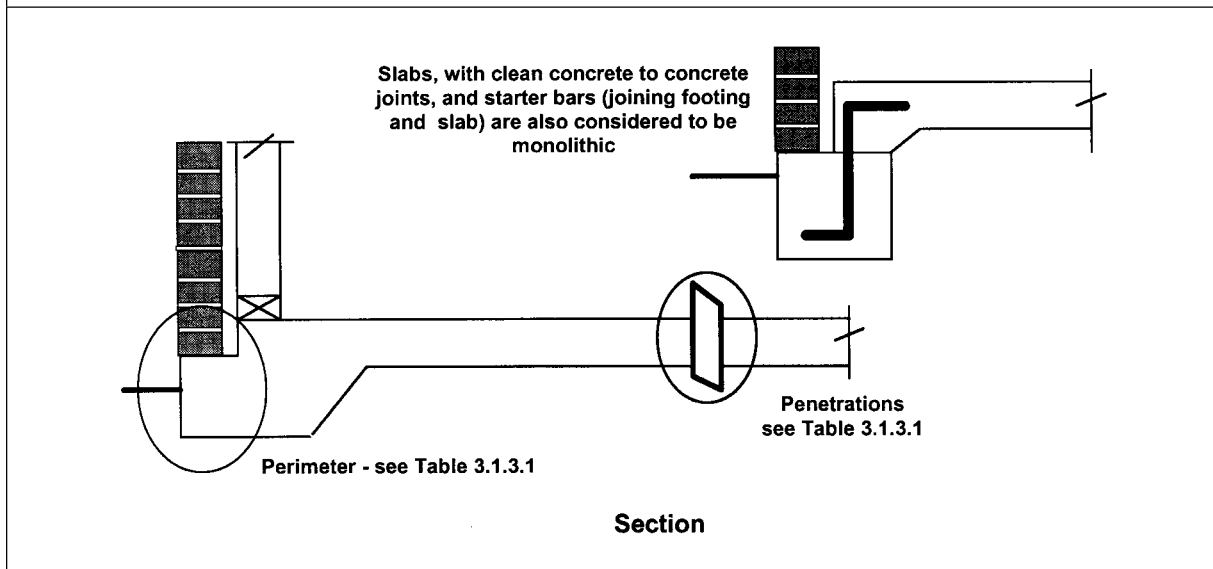
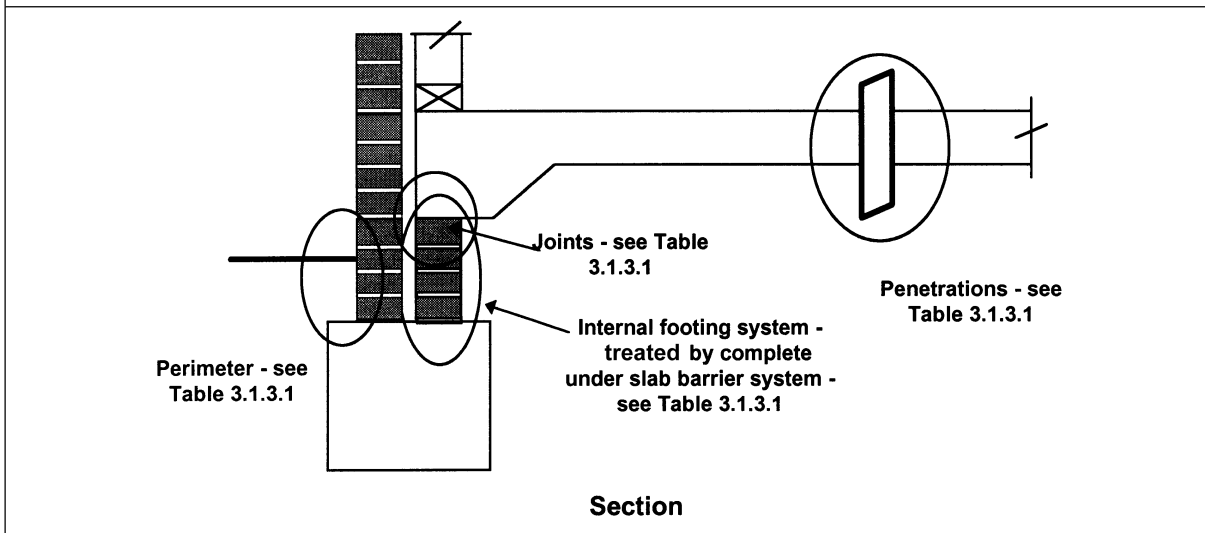

Figure
3.1.3.3
Amdt No. 9

Figure 3.1.3.3
AREAS TO BE TREATED FOR CONCRETE SLABS



Amdt 11

3.1.3.4 Barriers for suspended floors

3.1.3.4
Amdt No. 9

The area beneath a suspended floor of a building must be treated-

- by installing a barrier system in accordance with Table 3.1.3.1; and
- by providing sub-floor ventilation in accordance with Part 3.4.1; and
- where a barrier that needs to be inspected is installed, by providing access to the area of the barrier that needs inspection in accordance with AS 3660.1.

3.1.3.5 Attachments to buildings

3.1.3.5
Amdt No. 9

- Attachments to buildings such as downpipes and service pipes must have a gap to allow clear and uninterrupted visual inspection across the inspection zone.
- Structures such as steps, verandahs, porches, access ramps, carports, trellises, decks, hot-water systems, airconditioners, or the like which are not provided with one of the barrier systems described in this Part, must be separated from the building by a gap of not less than 25 mm, to allow clear and uninterrupted visual inspection across the inspection zone.
- Where attachments or structures, as outlined in (a) and (b), abut a building and there is no clear gap, a barrier must be provided to the attachment, regardless of the size of the attachment.
- For the purposes of this clause, an inspection zone is an unobstructed space which termite must cross or pass in order to gain access to a building or structure and, as a consequence, reveal their presence during visual inspection.

Expl. Info
Amdt No. 9

Explanatory information: Termites:

1. Barriers - Part of a system

There are more than 350 species of termites in Australia, about 30 of which achieve economic importance by causing costly damage to building structures. Due to the nature of termites, it is extremely difficult to prevent them gaining access to a building.

In addition to the correct installation of a termite barrier, its effectiveness will rely on regular maintenance and competent inspection.

The requirements in the BCA are minimum requirements and owners of buildings may choose to incorporate additional termite management systems in their buildings.

2. The slab as a barrier

A concrete slab, designed and constructed in accordance with AS 2870, can form part of an acceptable termite barrier system. Cracking of the slab is common and does not necessarily indicate the failure of the termite barrier. Most cracks, including those that may appear quite wide on the surface do not necessarily extend for the full depth of the slab.

3. Slab edge exposure

This approach is similar to that applied to termite shields in that termite activity is forced onto the exposed edge of the slab where with regular inspections termite ingress via the perimeter of the building can be detected.

The exposed edge of the slab should be kept clean. Debris such as leaves should be removed to ensure the full 75 mm of the slab is always visible.

4. Treatment of sub-floor areas

The area beneath a building requires special attention to ensure the effectiveness of the termite barrier. The following points should be observed.

a. Sub-floor ventilation - In suspended floor areas it is important that termite activity is not encouraged by inadequate subfloor ventilation. In conjunction with physical or chemical barriers air flow is critical. Air flow will not only restrict the growth of fungus which attacks subfloor members (which makes them more susceptible to termite attack), but also creates a climatic atmosphere less conducive to termite activity.

b. Subfloor access - Termite shielding installed below suspended floors relies on access for both inspection and maintenance to be effective. Accordingly, minimum clearance heights will need to be achieved between the building structure (including ducts) and the ground to allow easy access to all areas where termite shields are used.

Perimeter access doors will also be needed where access is required for inspection and maintenance.

Amdt 11

PART **3.2**

Amdt 11

FOOTINGS AND SLABS

- 3.2 Footings and slabs**
- 3.2.2 Preparation**
- 3.2.3 Concrete and Reinforcing**
- 3.2.4 Site Classification**
- 3.2.5 Footing and Slab Construction**

PART 3.2 FOOTINGS AND SLABS

	Page
3.2 Footings and slabs	7,021
3.2 Definitions	
3.2.0 Acceptable construction manual	
3.2.1 Application	
3.2.2 Preparation	7,201
3.2.2.1 Excavation for footings	
3.2.2.2 Filling under concrete slabs	
3.2.2.3 Foundations for footings and slabs	
3.2.2.4 Slab edge support on sloping sites	
3.2.2.5 Stepped footings	
3.2.2.6 Vapour barriers	
3.2.2.7 Edge rebates	
3.2.3 Concrete and reinforcing	7,401
3.2.3.1 Concrete	
3.2.3.2 Steel reinforcement	
3.2.4 Site classification	7,601
3.2.4.1 Site classification	
3.2.5 Footing and slab construction	7,801
3.2.5.1 Footing and slab construction	
3.2.5.2 Footings and slabs to extensions to existing buildings	
3.2.5.3 Shrinkage control	
3.2.5.4 Minimum edge beam dimensions	
3.2.5.5 Footings for fireplaces on Class A and S sites	
3.2.5.6 Stump footing details	

Amdt 11

Explanatory information:

This Part specifies the requirements for the excavation and filling for the footing or slab together with the construction of various alternative concrete slab and footing configurations.

The slab and footing configurations detailed in Part 3.2.5 are only suitable for the specified soil classifications. The requirements contained in the remainder of this Part are more general and may be applied to all slab and footing construction.

PART 3.2 FOOTINGS AND SLABS

Appropriate Performance Requirements:

Where an alternative footing system is proposed to that described in Part 3.2, that proposal must comply with-

- (a) Performance Requirement P2.1; and
- (b) Performance Requirement P2.2.3,
in Section 2.

Definitions

3.2 The following definitions are used in this Part:

Articulated masonry means masonry construction in which special provisions have been made for movement by articulation (see 3.3.1.8).

Clad frame means timber or metal frame construction with exterior timber or sheet wall cladding that is not sensitive to minor movement and includes substructure masonry walls up to 1.5 m high.

Controlled fill means material that has been placed and compacted in layers with compaction equipment (such as a vibrating plate) within a defined moisture range to a defined density requirement.

Finished ground level means the ground level adjacent to footing systems at the completion of construction and landscaping.

Footing means construction that transfers the load from the building to the *foundation*.

Loadbearing wall, for the purposes of this part, means any wall imposing on the footing a load greater than 10 kN/m.

Mixed construction means a building consisting of more than one form of construction, particularly in double-storey buildings.

Rolled fill means material placed in layers and compacted by repeated rolling by an excavator.

Single leaf masonry means outer walls constructed with a single thickness of masonry unit.

Waffle raft means a stiffened raft with closely spaced ribs constructed on the ground and with slab panels supported between ribs.

A. Acceptable construction manuals

3.2.0 Performance Requirements P2.1 and P2.2.3 are satisfied for footings and slabs if they are installed in accordance with one of the following manuals:

- (a) The footing or slab is constructed in accordance with AS 2870.
- (b) Piled footings are designed in accordance with AS 2159.

Explanatory information:

Composite construction - design requirements for other materials that may be used in combination with the above footing systems, including the use of heavy steel support beams etc. are described in Part 3.11 - structural design codes.

B. Acceptable construction practice**3.2.1 Application**

3.2.1
Amdt No. 6

Compliance with this Part satisfies *Performance Requirements* P2.1 and P2.2.3 for footings and slabs, provided-

- (a) the footing is on a Class A, S, M, M-D, H or H-D *site* (classified in accordance with AS 2870) with a uniform bearing capacity; and
- (b) the slab is not more than 25 m long; and
- (c) slabs containing permanent joints (eg construction joints) are not used; and
- (d) the structure supported by the footing does not contain-
 - (i) more than two trafficable floors; or
 - (ii) a wall height exceeding 8 m, excluding any gable; and
- (e) the footing does not support more than one concrete slab; and

Explanatory Information:

For the purpose of (e) split level slabs are considered as one slab.

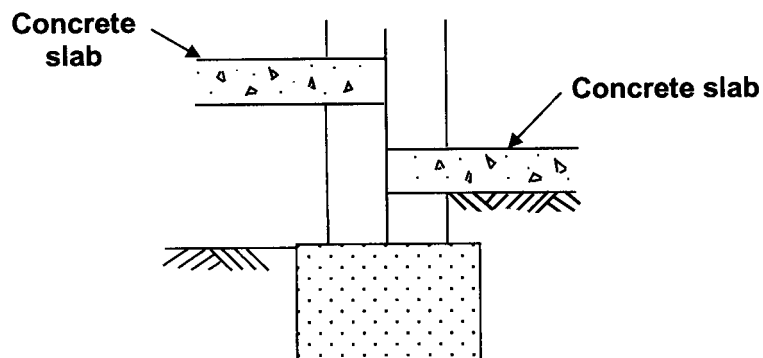
**DIAGRAM 1 - SPLIT LEVEL CONCRETE SLAB**

-
- (f) the building does not include wing walls or masonry arches not detailed for movement in accordance with Cement and Concrete Association of Australia TN 61; and
 - (g) single leaf earth or stone masonry walls do not exceed 3 m in height; and
 - (h) the *site* is considered to be normal as defined in Part 3.1.1, and
 - (i) the *site* is not located in an *alpine area*.

PART 3.2.2 PREPARATION

3.2.2.1 Excavation for footings

- (a) Excavation for footings, including thickenings for slabs and pads must be clean cut with vertical sides, wherever possible.
- (b) The base of the excavation must be-
 - (i) for flat *sites*, generally level but may slope not more than 1:40 to allow excavations to drain; and
 - (ii) sloping *sites* at an angle of not more than 1:10; and
 - (iii) stepped footings in accordance with 3.2.2.5.
- (c) Footing excavations must be free of loose earth, tree roots, mud or debris immediately before pouring concrete.
- (d) Topsoil containing grass roots must be removed from the area on which the footing will rest.
- (e) Excavation depths and soil cuts must comply with Part 3.1.1.

STATE AND TERRITORY VARIATIONS

3.2.2.1(e) does not apply in New South Wales.

Note: In New South Wales the Local Government Act 1993 and the Local Government (Approvals) Regulation 1993 regulate matters relating to *siteworks* associated with the erection of a building including, the safeguarding of excavations and backfilling, provision of retaining walls to prevent soil movement, and support for neighbouring buildings.

- (f) On loose sand *sites* or *sites* subject to wind or water erosion, the depth below *finished ground level* for footings must be not less than 300 mm.
- (g) Height of finished slab-on-ground must be in accordance with 3.1.2.3(b).

3.2.2.2 Filling under concrete slabs

3.2.2.2
Amdt No. 2

Filling placed under a slab (except where the slab is suspended) must comply with the following:

- (a) Filling must be either *controlled fill* or *rolled fill* as follows:
 - (i) Sand used in *controlled fill* or *rolled fill* must not contain any gravel size material and achieve a blow count of 7 or more per 300 mm using the test method described in AS 1289, Method 6.3.3.
 - (ii) Clay used in *controlled fill* or *rolled fill* must be moist during compaction.

Amdt 11

- (iii) *Controlled fill*:
 - (A) Sand fill up to 800 mm deep - well compacted in layers not more than 300 mm deep by vibrating plate or vibrating roller.
 - (B) Clay fill up to 400 mm deep - well compacted in layers of not more than 150 mm by a mechanical roller.
- (iv) *Rolled fill*:
 - (A) Sand fill up to 600 mm deep - compacted in layers of not more than 300 mm by repeated rolling by an excavator or other suitable mechanical equipment.
 - (B) Clay fill up to 300 mm deep - compacted in layers of not more than 150 mm by repeated rolling by an excavator or similar machine.
- (b) Fill with a depth greater than that specified in (a) must be installed in accordance with AS 3798.
- (c) A level layer of clean quarry sand must be placed on top of the fill, with a depth of not less than 20 mm.
- (d) A graded stone termite barrier complying with Part 3.1.3 may be substituted for the sand required in (c).

3.2.2.3 Foundations for footings and slabs

Footings and slabs, including internal and edge beams, must be founded on soil with an allowable bearing pressure as follows:

- (a) Slab panels, load support panels and internal beams - natural soil with an allowable bearing pressure of not less than 50 kPa or *controlled fill* or *rolled fill* compacted in accordance with 3.2.2.2.
- (b) Edge beams connected to the slab - natural soil with an allowable bearing pressure of not less than 50 kPa or *controlled fill* compacted in accordance with 3.2.2.2(a)(iii) and extending past the perimeter of the building 1 m with a slope ratio not steeper than 2 horizontal to 1 vertical (see Figure 3.2.2.1).
- (c) Pad footings, strip footings and edge beams not connected to the slab, must be-
 - (i) founded in natural soil with an allowable bearing pressure of not less than 100 kPa; or
 - (ii) for Class A and S *sites* they may be founded on controlled sand fill in accordance with 3.2.2.2(a).

3.2.2.4 Slab edge support on sloping sites

Footings and slabs installed on the low side of sloping *sites* must be as follows:

- (a) Slab panels - in accordance with 3.2.2.3(a).

- (b) Edge beams-
 - (i) supported by *controlled fill* in accordance with 3.2.2.3(b) (see Figure 3.2.2.1, Option 1); or
 - (ii) supported by deepened edge beams or bulk piers designed in accordance with AS 3600 (see Figure 3.2.2.1, Option 2); or
 - (iii) deepened (as per AS 2870) to extend into the natural soil level with a bearing capacity in accordance with 3.2.2.3(b) (see Figure 3.2.2.1, Option 3); or
 - (iv) stepped in accordance with AS 2870.
- (c) Edge beams not connected to the slab, pad footings and strip footings - founded in accordance with 3.2.2.3(c).
- (d) Where an excavation (cut) of the natural ground is used it must be in accordance with Part 3.1.1.

Amdt 11

Figure 3.2.2.1
SLAB EDGE SUPPORT ON THE LOW SIDE OF SLOPING SITES

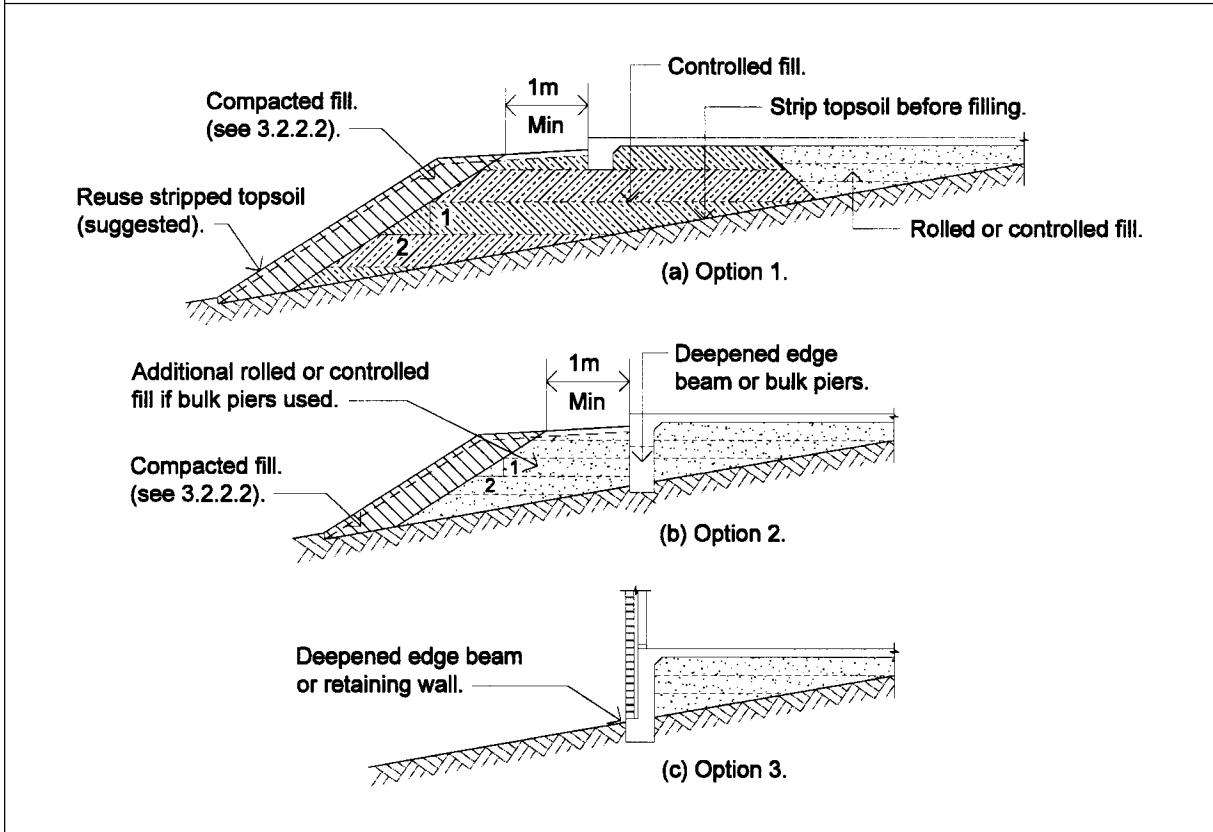

Expl. Info.
Amdt No. 4

Explanatory information:

The *foundations* of a building are critical to its successful performance. As such, the soil must have the strength or bearing capacity to carry the building load with minimum movement.

The bearing capacity of a soil varies considerably and needs to be determined on a *site* by *site* basis. For this to occur, the appropriate people need to be consulted. These people may include a qualified engineer or experienced engineering geologist, or it may be determined by a person with appropriate local knowledge. The minimum bearing capacity (soil strength rating) may depend on the *site* conditions. The soil may be naturally undisturbed or be disturbed by building work or the like. Where soil is disturbed by building work and the like, the bearing capacity can be dramatically altered. This is typically the case for sloping *sites* where cut and fill procedures are used. In these situations the soil needs to be consolidated, generally via compaction, to achieve the *required* bearing capacity.

There are a number of alternatives for working on cut and filled sites. These are described in Figure 3.2.2.1.

Option 1 of Figure 3.2.2.1 refers to the controlled fill process which involves the compaction of fill in layers to achieve the bearing capacity described in 3.2.2.3. The depth of fill for each layer is specified to ensure effective compaction. Fill beyond these depths will need to be installed in accordance with AS 3798.

Option 2 and 3 of Figure 3.2.2.1 refer to edge beams that extend through the fill into undisturbed soil which provides the 3.2.2.3 required bearing capacity. In this situation the fill is essentially only taking the internal slab loads.

Amdt 11

3.2.2.5 Stepped footings

Stepped strip footings must be constructed as follows-

- (a) the base of the footing must be horizontal or have a slope of not more than 1:10; or
- (b) be stepped in accordance with one of the methods shown in Figure 3.2.2.2.

Figure 3.2.2.2

STEPPED STRIP FOOTINGS

Note: All measurements in millimetres.

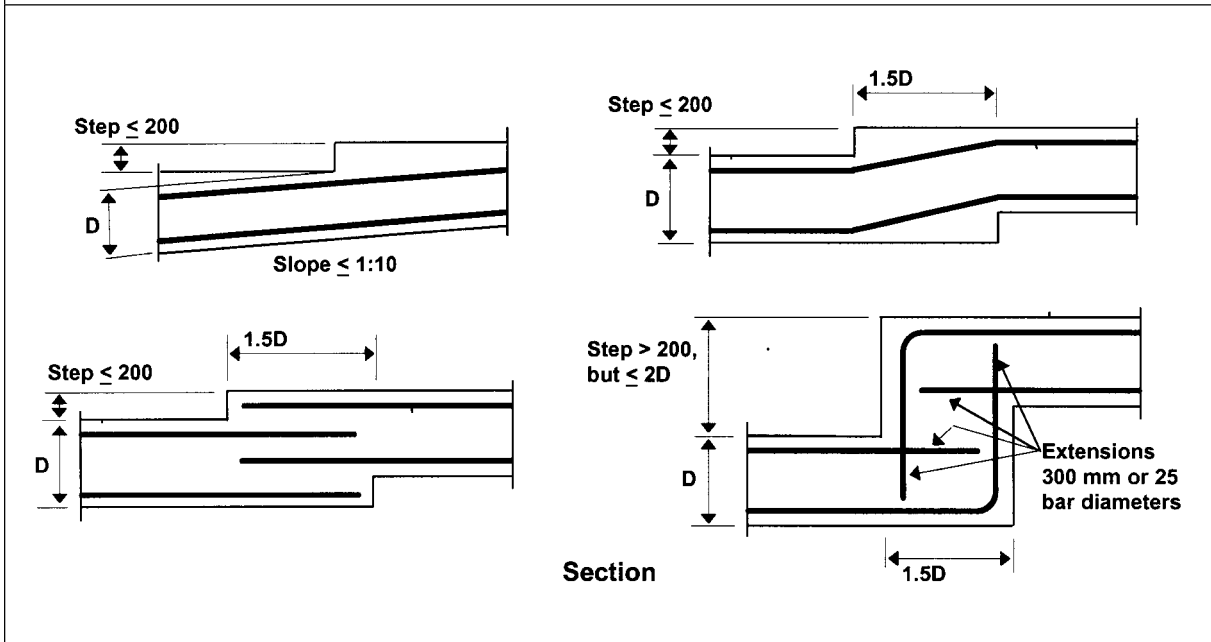

Amdt 11

3.2.2.6 Vapour barriers

A vapour barrier must be installed under slab-on-ground construction for all Class 1 buildings and for Class 10 buildings where the slab is continuous with the slab of a Class 1 building as follows-

(a) Materials

A vapour barrier must be-

- (i) 0.2 mm nominal thickness polyethylene film; and
- (ii) medium impact resistant,

determined in accordance with criteria specified in clause 5.3.3.2(c) of AS 2870; and

- (iii) be branded continuously "AS 2870 Concrete underlay, 0.2 mm Medium impact resistance".

(b) Installation

A vapour barrier must be installed as follows-

- (i) lap not less than 200 mm at all joints; and
- (ii) tape or seal with a close fitting sleeve around all service penetrations; and

- (iii) fully seal where punctured (unless for service penetrations) with additional polyethylene film and tape.
- (c) The vapour barrier must be placed beneath the slab so that the bottom surface of the slab is entirely underlaid and extends under edge beams to finish at ground level in accordance with Figure 3.2.2.3 (also see Figure 3.3.4.9 for single skin masonry details).

STATE AND TERRITORY VARIATIONS

In South Australia delete 3.2.2.6 and insert SA 3.2.2.6 as follows:

SA 3.2.2.6 Damp-proofing membrane

A continuous damp-proofing membrane must be installed under slab-on-ground construction for all Class 1 buildings as follows-

(a) Materials

A damp-proofing membrane must be-

- (i) 0.2 mm nominal thickness polyethylene film; and
- (ii) high impact resistant with resistance to puncturing and moisture penetration,

determined in accordance with criteria specified in clause 5.3.3.2(c) of AS 2870; and

- (iii) be branded continuously "AS 2870 Concrete underlay, 0.2 mm High impact resistance" together with the manufacturer's or distributor's name, trade mark or code.

(b) Installation

A damp-proofing membrane must be installed as follows-

- (i) lap not less than 200 mm at all joints; and
- (ii) tape or seal with a close fitting sleeve around all service penetrations; and
- (iii) fully seal where punctured (unless for service penetrations) with additional polyethylene film and tape.

- (c) The damp-proofing membrane must be placed beneath the slab so that the bottom surface of the slab is entirely underlaid and extends under edge beams to finish at ground level in accordance with Figure 3.2.2.3 (also see Figure 3.3.4.9 for single skin masonry details).

3.2.2.7 Edge rebates

Edge rebates for slab-on-ground, stiffened raft or *waffle raft* with masonry cavity or veneer construction must comply with the following:

- (a) The rebate must not be less than 20 mm, except as provided for in (d).
- (b) Exterior masonry must not overhang more than 15 mm past the edge of the slab.
- (c) The edge rebate must be flashed and drained in accordance with Part 3.3.4 and where it cannot be flashed it must be filled with mortar.
- (d) Edge rebates are not required for single-leaf masonry.

Explanatory information:

See 3.2.5.4 for minimum edge beam details.

Amdt 11

Figure 3.2.2.3
ACCEPTABLE VAPOUR BARRIER AND DAMP-PROOFING MEMBRANE LOCATION

Note: All dimensions in mm.

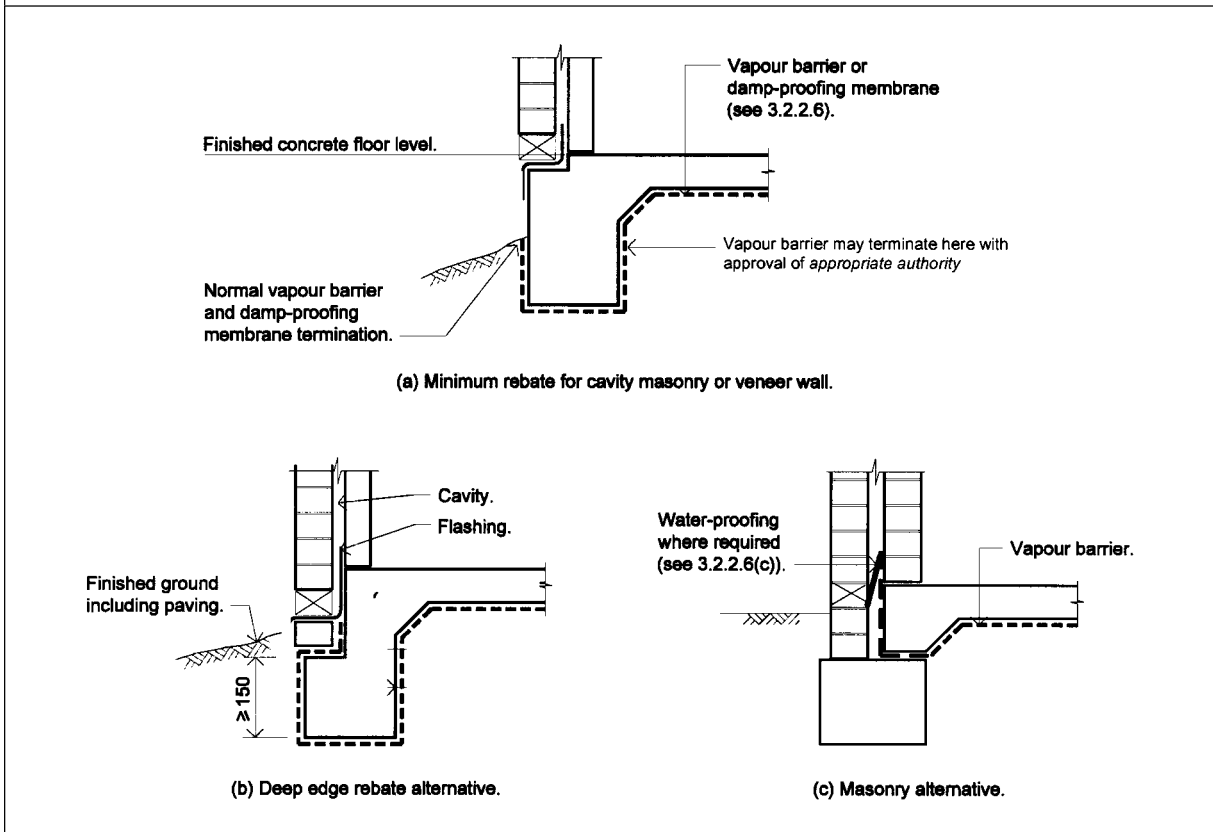

PART 3.2.3 CONCRETE AND REINFORCING

3.2.3.1 Concrete

Concrete must comply with the following:

- (a) Concrete must be manufactured to comply with AS 3600; and-
 - (i) have a strength at 28 days of not less than 20 MPa (denoted as N20 grade); and
 - (ii) have a 20 mm nominal aggregate size; and
 - (iii) have a nominal 80 mm slump.
- (b) Water must not be added to the mix to increase the slump to a value in excess of that specified.
- (c) Concrete must be placed and compacted in accordance with good building practice.
- (d) In hot (above 30°Celsius) and windy conditions concrete must be cured by covering with plastic sheeting, spraying with a liquid membrane curing compound or ponding of water on the top surface.

Amdt 11

STATE AND TERRITORY VARIATIONS

In South Australia after 3.2.3.1(d) insert SA 3.2.3.1(e), (f) and (g) as follows:

- (e) Concrete in slabs must be adequately compacted, and slab surfaces, including edges, moist cured for 7 days.
- (f) After vertical surfaces are stripped of formwork, slab edges must be finished prior to curing.
- (g) Loading of concrete slabs with stacked materials or building plant must not occur for a minimum of 7 days after pouring although construction of wall frames and setting out brickwork may be undertaken during this period.

Explanatory information:

Compacting concrete by vibration removes air pockets and works the concrete thoroughly around reinforcement, service penetrations etc and into corners of formwork to increase durability and resistance to termite infestation and salt damp attack. Care should be taken not to over-vibrate.

The finishing and curing of slab edges provides an improved edge finish which is resistant to edge dampness.

Explanatory information:

1. Complete discharge of the concrete from the truck should be made within one and a half hours of initial mixing with water unless a suitable retarder has been specified.
2. Care should be taken when using chemical curing methods, because some products may not be compatible with adhesives used to fix surface finishes to the slab.

3.2.3.2 Steel reinforcement

- (a) Materials used for reinforcing steel must comply with AS 2870 and be-
 - (i) welded wire reinforcing fabric; or
 - (ii) trench mesh; or
 - (iii) steel reinforcing bars.
- (b) Steel reinforcing bars may be substituted for trench mesh in accordance with Table 3.2.3.2.

Explanatory information:

Reinforcement types referenced in this Part are described as follows:

1. Square fabric - F62, F72, F82, F92 or F102 (eg F62 consists of 6 mm diameter wires spaced at 200 mm centres).
2. Trench mesh - designated as the number and size of the longitudinal wires required, eg. 3-8TM consists of 3 longitudinal 8 mm wires.
3. Steel reinforcing bars - are designated as x - Y12, x - Y16 etc where x is the number of bars required.

- (c) Minimum laps for reinforcement as shown in Table 3.2.3.1 and Figure 3.2.3.1 must be provided where reinforcing is used.

Table 3.2.3.1 MINIMUM LAP FOR REINFORCEMENT			
Reinforcement	Minimum splice (mm)	Minimum Lap at "T" intersections	Minimum Lap at "L" intersections
Steel reinforcing bars	500	Full width across the junction	One outer bar must be bent and continue 500 mm (min) around corner
Trench mesh	500	Full width across the junction	Full width across the junction
Square and Rectangular Mesh	The two outermost transverse wires of one sheet must overlap the two outermost transverse wires of the other.	Not applicable	Not applicable

Figure 3.2.3.1
LAPS IN REINFORCEMENT

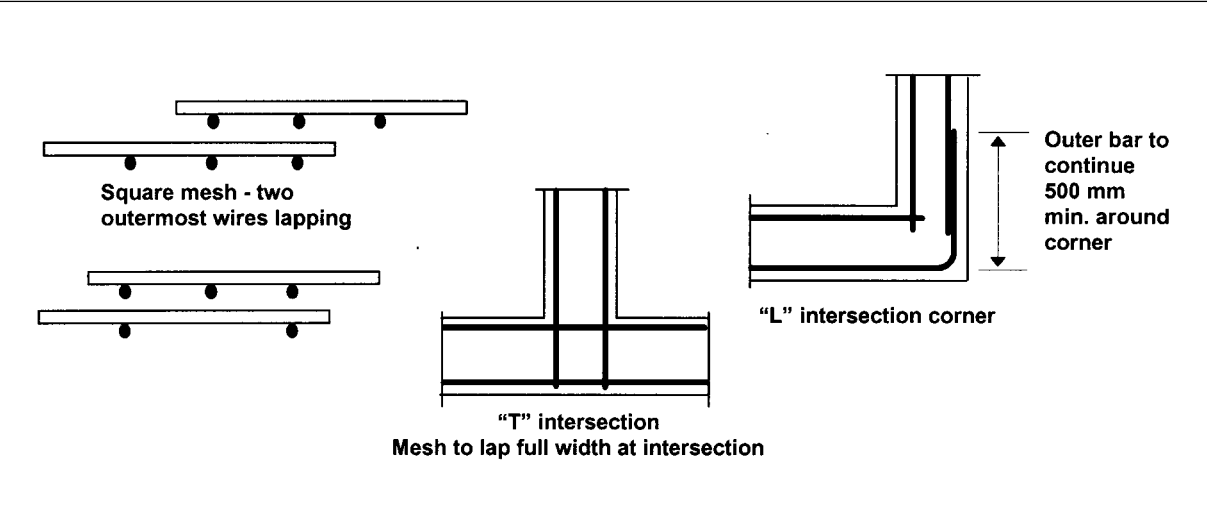

Amdt 11

Table 3.2.3.2
ALTERNATIVE MESH/REINFORCING BAR SIZES

Note: Where necessary 2 layers of mesh may be used.

Trench mesh (TM)	Area - mm ²	Reinforcing bar alternative	Trench mesh alternative
2-8TM	101	2-Y12	not applicable
3-8TM	151	2-Y12	not applicable
4-8TM	201	2-Y12	2-11TM
5-8TM	252	3-Y12	3-11TM
2-11TM	197	2-Y12	4-8TM
3-11TM	295	3-Y12	6-8TM
4-11TM	394	4-Y12	8-8TM
2-12TM	245	2-Y16	3-11TM
3-12TM	368	2-Y16	4-11TM
4-12TM	491	3-Y16	5-11TM

- (d) Footings and slabs on ground must have concrete cover between the outermost edge of the reinforcement (including ligatures, tie wire etc) and the surface of the concrete of not less than:
 - (i) 40 mm to unprotected ground.
 - (ii) 30 mm to a membrane in contact with the ground.
 - (iii) 20 mm to an internal surface.
 - (iv) 40 mm to external exposure.
- (e) Reinforcement must be cleaned of loose rust, mud, paints and oils immediately prior to the concrete pour.

Explanatory information:

In order to obtain a good bond between concrete and reinforcement, the reinforcement should be free of contamination by mud, paint, oils, etc. It is not necessary for the reinforcement to be completely free of rust. Some rusting is beneficial in promoting a good bond as it roughens the surface of the steel. Loose rust, however, must be removed from the reinforcement.

- (f) Reinforcement must be placed as follows:
 - (i) All reinforcement must be firmly fixed in place to prevent it moving during concreting operations.
 - (ii) Reinforcement must be supported off the ground or the forms by bar chairs made from wire, concrete or plastic.
 - (iii) When using wire chairs the minimum concrete cover (see 3.2.3.2(d)) to the uncoated portion of the chair must be obtained.
 - (iv) Wire chairs on soft ground or plastic membrane must be placed on flat bases.
 - (v) Bar chairs must be spaced at not more than 800 mm centres for steel fabric.

Explanatory information:

Reinforcement is designed to be in a particular place so as to add strength or to control cracking of the concrete. A displacement from its intended location could make a significant difference to the life or serviceability of the structure.

Supports for fabric reinforcement are provided to prevent the fabric distorting when workers walk on top of it to place the concrete and maintain the correct concrete cover to the fabric.

PART 3.2.4 SITE CLASSIFICATION

3.2.4.1 Site classification

The *foundation* where the footing is to be located must be classified in accordance with AS 2870.

3.2.4.1
Expl. Info.
Amdt No. 6

Explanatory information:

Table 3.2.4.1 provides a general description of *foundation* soil types that will assist in the classification of the *site*. More detailed information, including differentiation between classifications, can be found in AS 2870 or alternatively contact the *appropriate authority*.

Due to the limitations of this Part, if a *site* is classified as E or P then reference must be made to AS 2870 for design and construction information.

Amdt 11

Table
3.2.4.1
Amdt No. 6

Explanatory information:

Table 3.2.4.1

GENERAL DEFINITION OF SITE CLASSES

Class	Foundation
A	Most sand and rock <i>sites</i> with little or no ground movement from moisture changes
S	Slightly reactive clay <i>sites</i> with only slight ground movement from moisture changes
M	Moderately reactive clay or silt <i>sites</i> which can experience moderate ground movement from moisture changes
H	Highly reactive clay <i>sites</i> which can experience high ground movement from moisture changes
E	Extremely reactive clay <i>sites</i> which can experience extreme ground movement from moisture changes
A to P	Filled <i>sites</i> - see AS 2870
P	<i>Sites</i> which include soft soils, such as soft clay or silt or loose sands; landslip; mine subsidence; collapsing soils; soils subject to erosion; reactive <i>sites</i> subject to abnormal moisture conditions or <i>sites</i> which cannot be classified otherwise

Note: For classes M, H and E further division based on the depth of the expected movement is *required*. For deep-seated movements, characteristic of dry climates and corresponding to a design depth of suction change H_s , equal to or greater than 3 m, the classification shall be M-D, H-D or E-D as appropriate. For example, H-D represents a highly reactive *site* with deep moisture changes, and H represents a highly reactive *site* with shallow moisture changes.

PART 3.2.5 FOOTING AND SLAB CONSTRUCTION

Explanatory information:

The footings included in this Part reflect the requirements of AS 2870 and apply to the most common types of soil conditions. If the soil conditions on *site* are not covered by this Part then additional guidance can be obtained from AS 2870 or the *appropriate authority*.

These provisions are not meant to prohibit the use of alternative traditional footing methods found through experience to be suitable for local soil conditions (especially those used in stable soils). Such footings may be appropriate, provided they meet the relevant *Performance Requirements* listed in Section 2.

The diagrams in this Part reflect acceptable footing designs only. They do not provide details for termite barriers such as the correct placement of ant capping and slab edge exposure.

For details on termite barriers see Part 3.1.3.

Amdt 11

3.2.5.1 Footing and slab construction

3.2.5.1(a)
Amdt No. 6

- (a) Footing and slab construction, including size and placement of reinforcement, must comply with the relevant provisions of this Part and the following details:
- (i) Footings for stumps - the appropriate details in 3.2.5.6 and Table 3.2.5.2.
 - (ii) Stiffened raft Class A, S, M, M-D, H and H-D *sites* - the appropriate details in Figure 3.2.5.3(a) and Figure 3.2.5.3(b).
 - (iii) Strip footing systems in Class A, S, M, M-D and H *sites* - the appropriate details in Figure 3.2.5.4(a) and Figure 3.2.5.4(b).
 - (iv) Footing slabs for Class A *sites* - the appropriate details in Figure 3.2.5.5.
- (b) Footings for *single leaf masonry*, *mixed construction* and *earth wall masonry* must comply with the equivalent footing construction set out in Table 3.2.5.1.

3.2.5.2 Footings and slabs to extensions to existing buildings

- (a) Footings to extensions to Class 1 or 10 buildings may be of similar proportions and details to those used with an existing same Class of building on the same allotment provided-
- (i) masonry and masonry veneer walls are articulated at the junction with the existing building; and
 - (ii) the performance of the existing building has been satisfactory, i.e. there has been no significant cracking or movement (see Section 2 of AS 2870 for acceptable footing performance); and
 - (iii) there are no unusual moisture conditions on the *site*.

- (b) Class 10 buildings of *clad framed* construction may use footing systems appropriate for one class of reactivity less severe than for a house.
 e.g. Site classification M can be reduced to S.

Table 3.2.5.1 EQUIVALENT FOOTING CONSTRUCTION		
Actual construction		Equivalent footing construction (see Figure 3.2.5.2 to 5)
External walls	Internal walls	
Single leaf masonry		
Reinforced <i>single leaf masonry</i>	<i>Articulated masonry</i> on Class A and S sites; or framed	<i>Articulated masonry veneer</i>
Reinforced <i>single leaf masonry</i>	<i>Articulated masonry</i> or reinforced <i>single leaf masonry</i>	Masonry veneer
<i>Articulated single leaf masonry</i>	<i>Articulated masonry</i>	Articulated full masonry
Mixed construction		
Full masonry	Framed	Articulated full masonry
Articulated full masonry	Framed	Masonry veneer
Earth wall masonry		
Infill panels of earth masonry	Framed earth masonry	<i>Articulated masonry veneer</i>
<i>Loadbearing</i> earth masonry	<i>Loadbearing</i> earth masonry	Articulated full masonry

3.2.5.3 Shrinkage control

- (a) Where brittle floor coverings are to be used (such as ceramic tiles) one of the following additional measures must be taken to control the effect of shrinkage cracking-
- (i) the amount of shrinkage reinforcement (steel reinforcement fabric in the slab panel) must be increased to F92 or equivalent throughout the affected slab panels; or
 - (ii) the bedding system for brittle coverings must be selected on the basis of the expected slab movement and the characteristics of the floor covering (including the use of expansion joints etc.); or
 - (iii) the placement of floor covering must be delayed for not less than 3 months.

Amdt 11

- (b) At re-entrant or internal corners, two strips, 2 m in length, of 3-8TM or one strip of 3-11TM (or 2-Y12 bars) must be placed diagonally across the corner in accordance with Figure 3.2.5.1.

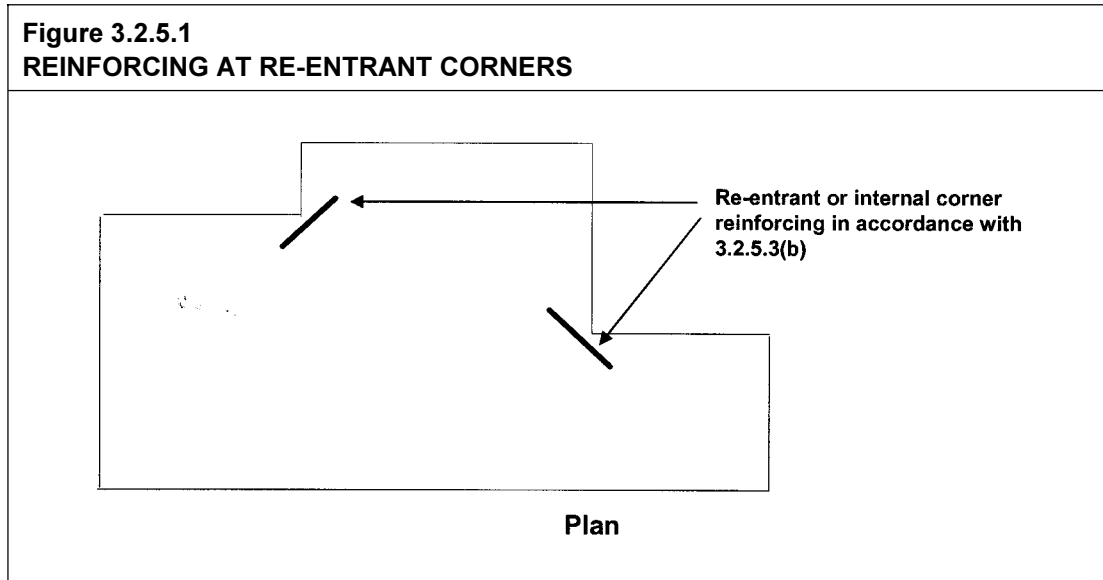

3.2.5.4 Minimum edge beam dimensions

Except for *waffle raft* slabs, where the edge rebate is more than 150 mm in depth, the width of the edge beam at the base of the rebate must not be less than 200 mm, except that if R10 ties at 900 mm spacing (or equivalent) are provided to resist vertical forces, the width of the edge beam can be reduced to 150 mm.

3.2.5.5 Footings for fireplaces on Class A and S sites

- (a) Fireplaces must be supported on a pad footing-
- (i) 150 mm thick for single storey (one trafficable floor and a wall height not more than 4.2 m) construction; and
 - (ii) 200 mm thick for 2 storey (two trafficable floors and a wall height not more than 8 m) construction; and
 - (iii) reinforced top and bottom with F72 mesh; and
 - (iv) extending 300 mm past the edges of the masonry except for any edge flush with the outer wall.
- (b) The pad footing may form an integral part of the slab.

3.2.5.6 Stump footing details

- (a) Footings for stumps must comply with-
- (i) the provisions of Table 3.2.5.2 for Class A and Class S sites; or

- (ii) the appropriate acceptable construction manual listed in-
 - (A) Part 3.4.3; or
 - (B) 3.2.0.
- (b) Concrete stumps must-
 - (i) be designed in accordance with-
 - (A) AS 3600; or
 - (B) Table 3.2.5.2; and
 - (ii) use a minimum 20 MPa concrete as defined in AS 3600.
- (c) Steel stumps must be-
 - (i) designed in accordance with-
 - (A) AS 4100; or
 - (B) Table 3.2.5.2; and
 - (ii) fully enclosed and sealed with a welded top plate; and
 - (iii) encased in concrete sloping away from the stump and finishing not less than 100 mm above *finished ground level*; and
 - (iv) corrosion protected in accordance with Part 3.4.4.
- (d) Timber stumps must be designed in accordance with-
 - (i) AS 1684 Parts 2, 3 or 4; or
 - (ii) Table 3.2.5.2.
- (e) Stumps must be braced-
 - (i) by a full perimeter masonry base; or
 - (ii) for concrete stumps - in accordance with AS 3600; or
 - (iii) for steel stumps - in accordance with AS 4100; or
 - (iv) for timber stumps - in accordance with AS 1684 Parts 2, 3 or 4.
- (f) Stumps must be embedded into the foundation material not less than 30% of their height above ground level or 450 mm, whichever is the greater.

3.2.5.6
(c)(i)(A)
Amdt No. 6

3.2.5.6(d)
Amdt No. 8

3.2.5.6(e)
Amdt No. 8

Amdt 11

**Table
3.2.5.2
Amdt No. 3**

Table 3.2.5.2 STUMP FOOTING - IN AREAS WITH A DESIGN WIND SPEED OF NOT MORE THAN W33				
LENGTH OF STUMP (mm) (including embedded length)	CONCRETE		STEEL	TIMBER
	Minimum size (mm)	REINFORCEMENT Number of 5 mm (min.) hard drawn wires	Minimum size (mm) (SHS = square hollow section)	Minimum size (mm)
Less than 1400	100 x 100 or 110 diameter	1	75 x 75 x 2.0 SHS	100 x 100 or 110 diameter
1401-1800	100 x 100 or 110 diameter	2	75 x 75 x 2.0 SHS	100 x 100 or 110 diameter
1801-3000	125 x 125 or 140 diameter	2	75 x 75 x 2.0 SHS	100 x 100 or 110 diameter

Amdt 11

Figure 3.2.5.2
Amdt No. 3

Figure 3.2.5.2
PAD FOOTINGS FOR CLAD FRAME, CLASS A AND S SITES

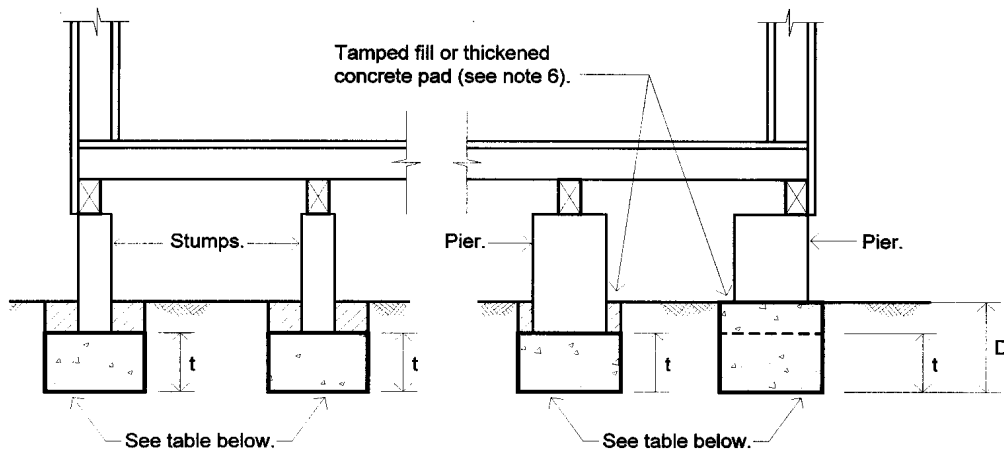

MINIMUM DIMENSIONS OF CIRCULAR AND SQUARE PAD FOOTINGS FOR CLAD FRAME CLASS A AND S SITES

Effective supported areas – m ²	Width of square pad – mm	Width of circular pad – mm	Thickness (t) – mm	Depth – mm
10	400	500	200	400
20	500	600	200	400
30	600	750	250	400

Notes:

- The effective area supported by a pad footing is the sum of-
 - the supported floor area; and
 - the supported roof area (if applicable); and
 - half the supported wall area in elevation (if applicable).
- The width or diameter can be reduced to one half the above footings on rock.
- The pad footings must be constructed in concrete except that masonry footings can be used under masonry piers.
- Pad footing sizes must also apply to footings supporting roof and floor loads only.
- The *foundation* must provide an allowable bearing pressure of not less than 100 kPa.
- The excavation must be backfilled with manually rodded tamped soil, or the footing thickness shall be increased by 50 mm.
- Where stump pad footings provide resistance to horizontal or uplift forces, the minimum size of the footing must comply with AS 2870.
- Braced stumps must comply with 3.2.5.6(e).

Amdt 11

Figure 3.2.5.3(a)
Amdt No. 6

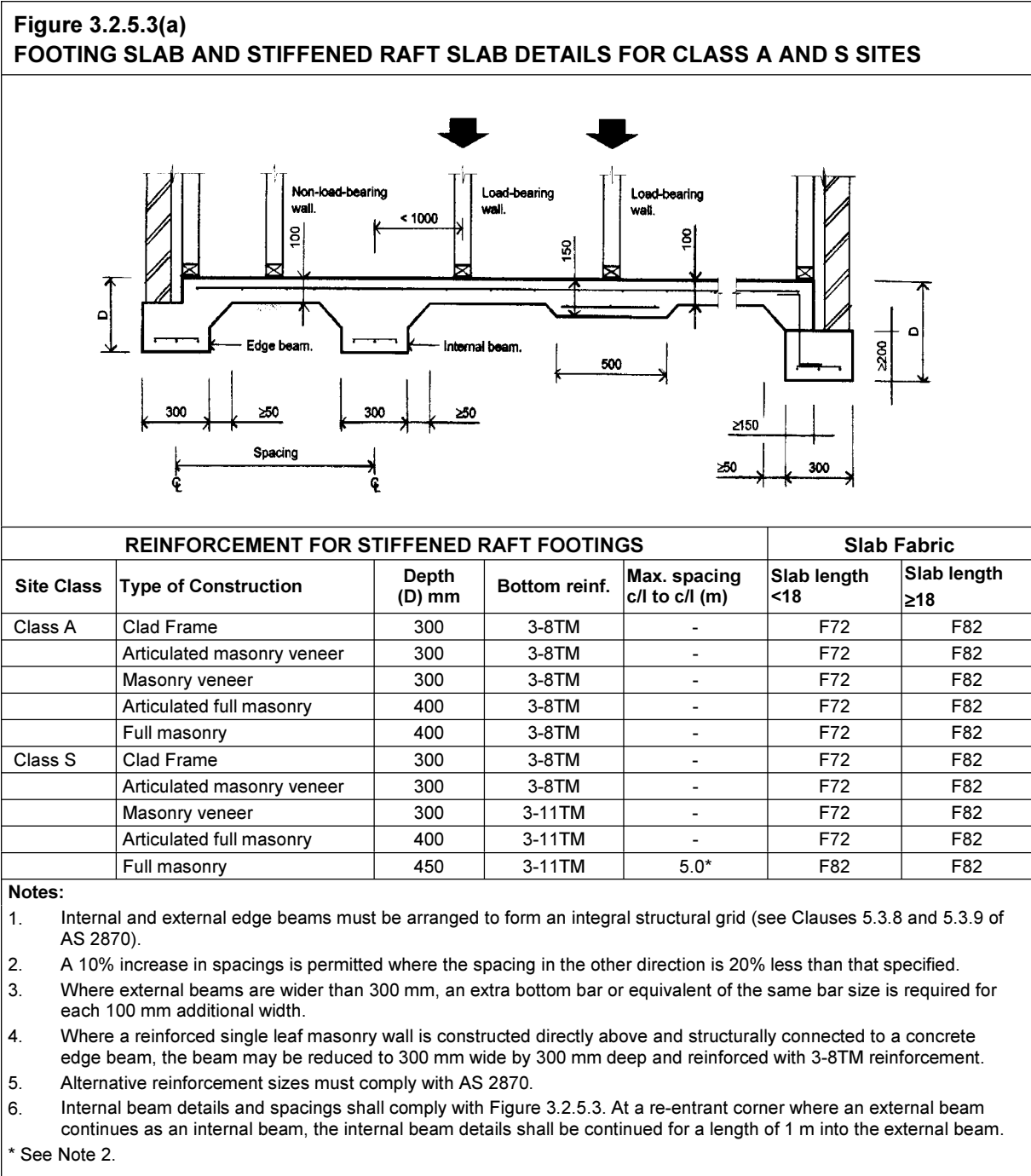

Amdt 11

Figure 3.2.5.3(b)
Amdt No. 6

Figure 3.2.5.3(b)
FOOTING SLAB AND STIFFENED RAFT SLAB DETAILS FOR CLASS M, M-D, H AND H-D SITES

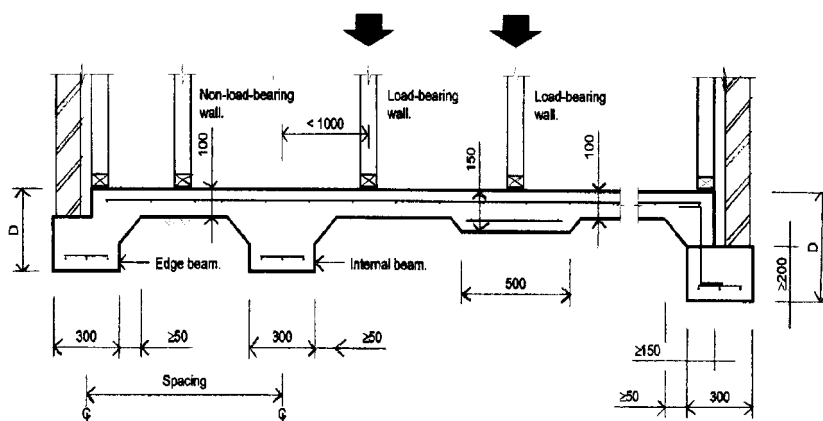

REINFORCEMENT FOR STIFFENED RAFT FOOTINGS

Slab Fabric

Site Class	Type of Construction	Depth (D) mm	Bottom reinf.	Max. spacing c/l to c/l (m)	Slab Fabric	
					Slab length <18	Slab length ≥18
Class M	Clad Frame	300	3-11TM	6.0*	F72	F82
	Articulated masonry veneer	400	3-11TM	6.0*	F72	F82
	Masonry veneer	400	3-11TM	5.0*	F72	F82
	Articulated full masonry	500	3-12TM	4.0	F82	F82
	Full masonry	800	3-Y16	4.0	F92	F92
Class M-D	Clad Frame	400	3-11TM	5.0*	F72	F82
	Articulated masonry veneer	400	3-11TM	4.0	F72	F82
	Masonry veneer	500	3-12TM	4.0	F82	F82
	Articulated full masonry	625	3-12TM	4.0	F92	F92
	Full masonry	-	-	-	-	-
Class H	Clad Frame	400	3-11TM	5.0*	F72	F82
	Articulated masonry veneer	500	3-12TM	4.0	F82	F82
	Masonry veneer	700	3-Y16	4.0	F92	F92
	Articulated full masonry	1000	4-Y16	4.0	F102	F102
	Full masonry	-	-	-	-	-
Class H-D	Clad Frame	500	3-11TM	4.0	F82	F82
	Articulated masonry veneer	600	3-12TM	4.0	F92	F92
	Masonry veneer	-	-	-	-	-
	Articulated full masonry	1200	4-Y16	4.0	F102	F102
	Full masonry	-	-	-	-	-

Notes:

1. Internal and external edge beams must be arranged to form an integral structural grid (see Clauses 5.3.8 and 5.3.9 of AS 2870).
2. A 10% increase in spacings is permitted where the spacing in the other direction is 20% less than that specified.
3. Where external beams are wider than 300 mm, an extra bottom bar or equivalent of the same bar size is required for each 100 mm additional width.
4. Where a reinforced single leaf masonry wall is constructed directly above and structurally connected to a concrete edge beam, the beam may be reduced to 300 mm wide by 300 mm deep and reinforced with 3-8TM reinforcement.
5. Alternative reinforcement sizes must comply with AS 2870.
6. Internal beam details and spacings shall comply with Figure 3.2.5.3. At a re-entrant corner where an external beam continues as an internal beam, the internal beam details shall be continued for a length of 1 m into the external beam.

* See Note 2.

Figure 3.2.5.4(a)
Amdt No. 6

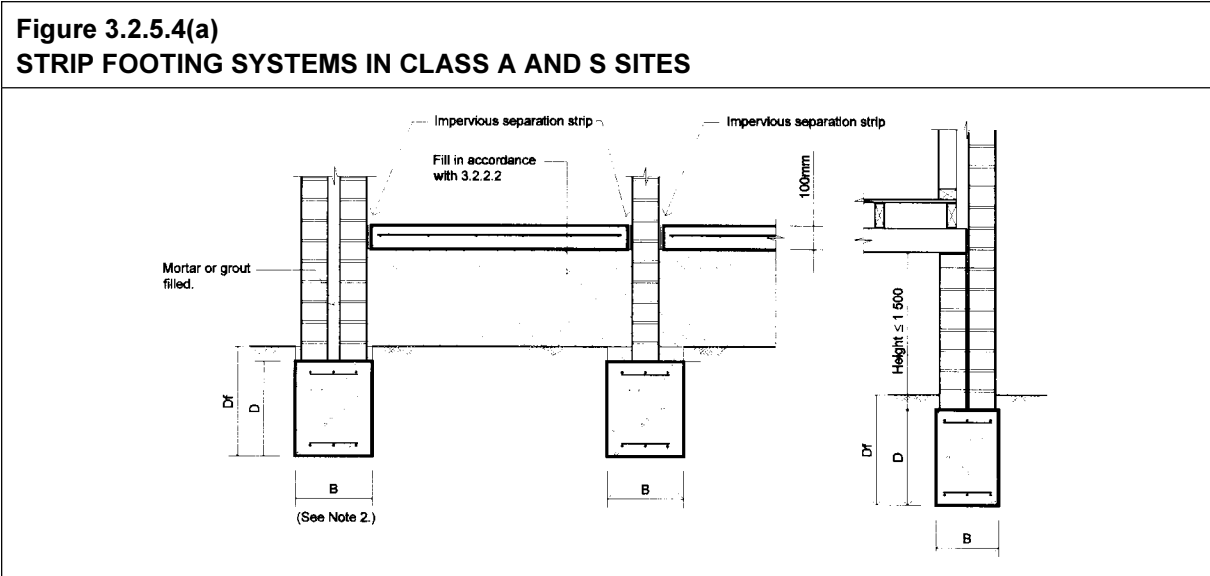

DIMENSIONS AND REINFORCEMENT FOR STRIP FOOTING SYSTEMS

Site Class	Type of construction	D	B	Reinforcement	D _f
Class A	Clad frame	300	300	3-8TM	400
	Articulated masonry veneer	300	300	3-8TM	400
	Masonry veneer	300	300	3-8TM	400
	Articulated full masonry	300	400	4-8TM	400
	Full masonry	300	400	4-8TM	400
Class S	Clad frame	400	300	3-8TM	400
	Articulated masonry veneer	400	300	3-8TM	400
	Masonry veneer	400	300	3-8TM	400
	Articulated full masonry	400	400	4-11TM	400
	Full masonry	500	400	4-11TM	400

- Notes:**
- All masonry walls must be supported on strip footings.
 - Internal strip footings shall be of the same proportions as the external footings and run from external footing to external footing. 'Side slip joints' consisting of a double layer of polyethylene shall be provided at the sides of the footing only.
 - Infill floors may be concrete slabs, brick paving, stone flags or compacted and stabilised earth. For concrete slab infill panels, mesh may be required to control shrinkage in slab panels and around openings or restrained regions. Concrete infill slabs must use a minimum of F62 mesh to control shrinkage (see also Clause 3.2.5.3).
 - Where footings are wider than the specified width, an extra bottom bar or equivalent of the same bar size is required for each 100 mm additional width. If strip footings deeper than those are required are used, the reinforcement shall be increased to match that specified for the deepened proportions.
 - The measurement of D_f is greater or equal to D plus 75 mm.
 - Alternative reinforcing sizes must comply with AS 2870.

Amdt 11

Figure 3.2.5.4(b)
Amdt No. 6

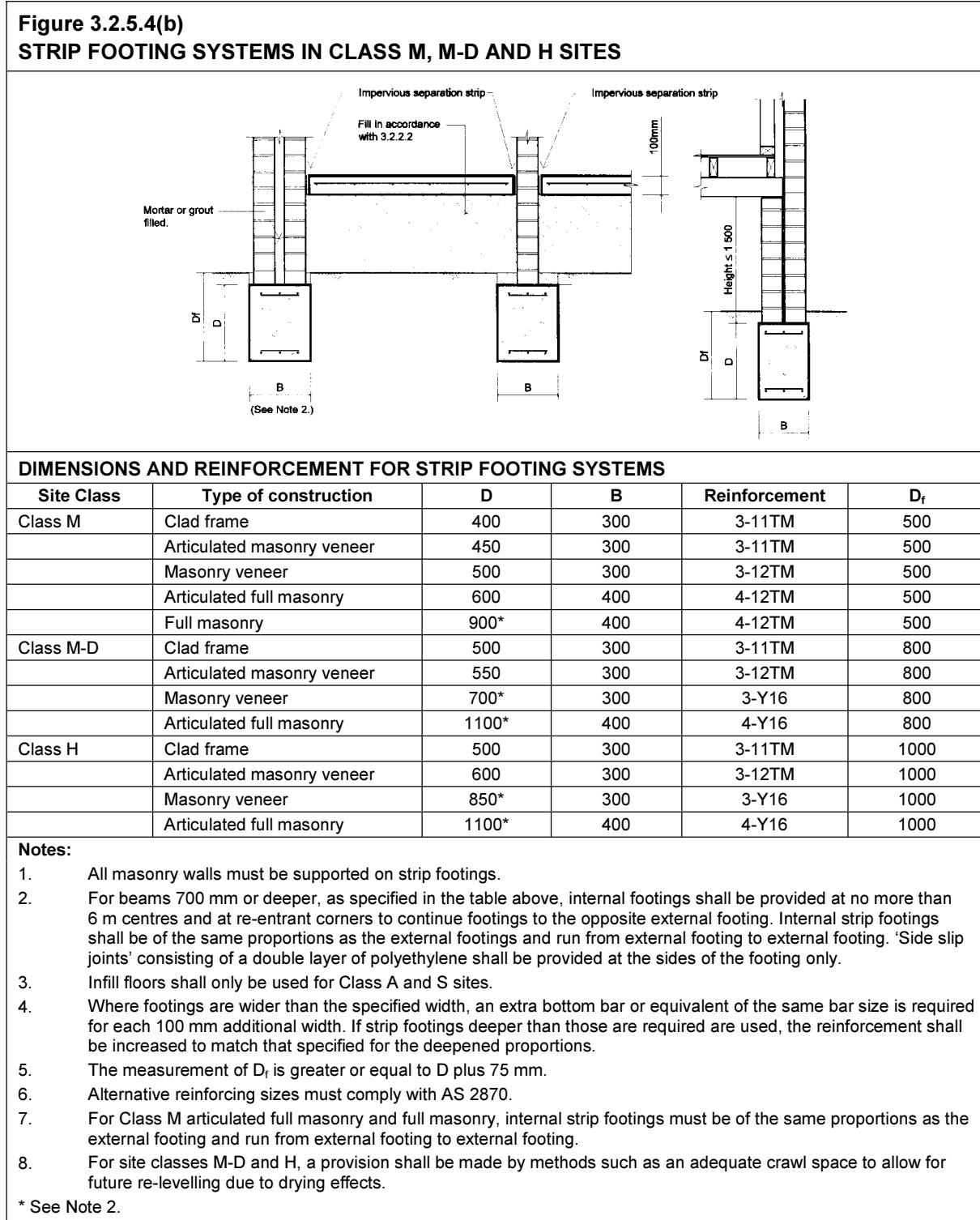

Amdt 11

Figure 3.2.5.5
FOOTING SLABS FOR CLASS A SITES SUITABLE FOR:

- (a) CLAD FRAME.
- (b) ARTICULATED MASONRY VENEER.
- (c) MASONRY VENEER.
- (d) ARTICULATED FULL MASONRY.
- (e) FULL MASONRY.

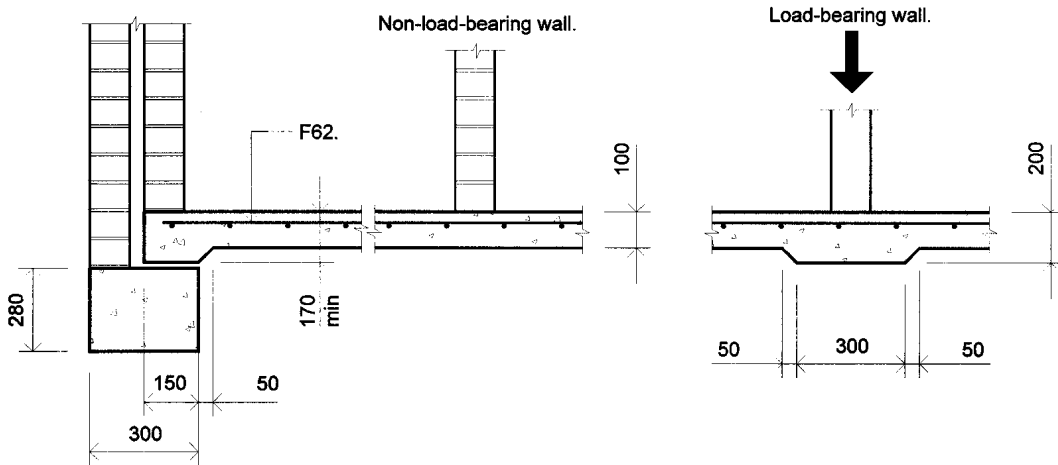

Notes:

1. Use F63 when slab length is less than or equal to 12 m.
2. Use F62 when slab length is less than or equal to 18 m.
3. Use F72 when slab length is more than 18 m.
4. In parts of Western Australia (around Perth) and other locations where the *site* consists of extremely stable sands, and where specified by a *professional engineer*, the slab thickness may be reduced to 85 mm and reinforced as follows:
 - (a) Use F53 when slab length is less than or equal to 12 m.
 - (b) Use F63 when slab length is less than or equal to 18 m.
 - (c) Use F62 when slab length is more than 18 m.
5. Dune sands may require compaction.

Amdt 11

PART **3.3**

Amdt 11

MASONRY

- 3.3** **Definitions**
- 3.3.1** **Unreinforced Masonry**
- 3.3.2** **Reinforced Masonry**
- 3.3.3** **Masonry Accessories**
- 3.3.4** **Weatherproofing of Masonry**
- 3.3.5** **Earthwall Construction**

PART 3.3 MASONRY

	Page
3.3 Definitions	9,012
3.3.1 Unreinforced masonry	9,021
3.3.1.0 Acceptable construction manual	
3.3.1.1 Application	
3.3.1.2 External walls	
3.3.1.3 Internal walls	
3.3.1.4 Isolated piers	
3.3.1.5 Masonry units	
3.3.1.6 Mortar mixes	
3.3.1.7 Mortar joints	
3.3.1.8 Vertical articulation joints	
3.3.1.9 Sub-floor ventilation	
3.3.1.10 Shrinkage allowance for timber framing	
3.3.2 Reinforced masonry	9,301
3.3.2.0 Acceptable construction manual	
3.3.2.1 Application	
3.3.2.2 External wall construction	
3.3.3 Masonry accessories	9,601
3.3.3.0 Acceptable construction manual	
3.3.3.1 Application	
3.3.3.2 Wall ties	
3.3.3.3 Fixing straps and tie down systems	
3.3.3.4 Lintels	
3.3.4 Weatherproofing of masonry	9,801
3.3.4 Application of this Part	
3.3.4.0 Acceptable construction manual	
3.3.4.1 Application	
3.3.4.2 Width of cavity	
3.3.4.3 Cavity ventilation and drainage	
3.3.4.4 Damp-proof courses - materials	
3.3.4.5 Damp-proof courses - installation	
3.3.4.6 Flashings	
3.3.4.7 Location of flashings	
	Continued

Amdt 11

Continued		
3.3.4.8	Flashings at the base of cavity walls	
3.3.4.9	Sill and head flashing	
3.3.4.10	Flashings at a roof abutting a wall	
3.3.4.11	Chimney flashings	
3.3.4.12	Weatherproofing for single skin masonry walls	
3.3.5	Earthwall construction	10,101
3.3.5	Definitions	
3.3.5.0	Acceptable construction manual	
3.3.5.1	Application	
3.3.5.2	General construction	
3.3.5.3	Minimum thickness of walls	
3.3.5.4	Weatherproofing	

Amdt 11

Definitions

3.3 The following definitions are used in this Part:

3.3
Amdt No. 11

Bond beam means a reinforced concrete or masonry member which acts as a lintel or stiffening beam to the masonry.

Cavity means a void between 2 leaves of masonry, or in masonry veneer construction, a void between a leaf of masonry and the supporting frame.

Engaged pier means a pier bonded to a masonry wall by course bonding of masonry units or by masonry ties.

Lateral support means a support (including footing, buttress, cross wall, beam, floor or braced roof structure) that effectively restrains the wall or pier at right angles to the face of the wall or pier.

Perpend means a vertical joint between adjacent masonry units.

Reinforced masonry means masonry reinforced with steel reinforcement that is placed in a bed joint or grouted into a core to strengthen the masonry.

Unreinforced masonry means masonry that is not reinforced.

PART 3.3.1 UNREINFORCED MASONRY

Appropriate Performance Requirements

Where an alternative masonry walling system is proposed to that described in Part 3.3.1, that proposal must comply with *Performance Requirement P2.1* as specified in Section 2.

A. Acceptable construction manual

3.3.1.0 *Performance Requirement P2.1* is satisfied for *unreinforced masonry* (including masonry-veneer) if it is designed and constructed in accordance with AS 3700 Masonry structures.

3.3.1.0
Amdt No. 11

Explanatory information:

Composite construction: Design requirements for other materials that may be used in combination with masonry ie heavy steel support beams etc. are described in Part 3.11 - Structural design.

B. Acceptable construction practice

3.3.1.1 Application

Compliance with this part satisfies *Performance Requirement P2.1* for *unreinforced masonry*, provided-

- (a) the *unreinforced masonry* is constructed on footings that comply with Part 3.2; and
- (b) the building is located in an area with a *design wind speed* of not more than W41; and
- (c) for earthquake design, the building is defined as a design category H1 or H2 domestic structure in accordance with AS 1170.4; and

Explanatory information:

1. This covers all *sites* except those identified by the site investigation as having soft soil (having a soil profile with more than 5 m of soft clay, loose sand, silt or uncontrolled fill) as defined by AS 1170.4.
2. For earthquake design H3, see AS 3700.

- (d) the building is not constructed in an *alpine area*; and
- (e) masonry accessories, including wall ties and lintels are installed in accordance with Part 3.3.3.

3.3.1.2 External walls**3.3.1.2
Amdt No. 11**

- (a) Masonry veneer must comply with the relevant provisions of this Part and be constructed as follows:
- (i) Bracing requirements - masonry veneer *external walls* must be tied to a *loadbearing* frame constructed in accordance with Part 3.4.
 - (ii) Masonry veneer walls, *non-loadbearing*, must be constructed with a leaf of masonry not less than 90 mm wide.
- (b) *Cavity* masonry and solid masonry walls must comply with the relevant provisions of this Part and be constructed as follows:
- (i) The height of the wall between *lateral supports* (floor or roof) must be not more than 3 m with the exception of a gable where the height to the ridge from a floor which serves as lateral support may be not more than 5 m (refer to Figure 3.3.1.1).
 - (ii) Masonry cross walls must be-
 - (A) not less than 2 m in length at not more than 9 m centres; and
 - (B) connected directly or by a floor or ceiling diaphragm to the wall being supported.
- (c) *Cavity* walls must be constructed of two leaves, with each leaf not less than 90 mm wide.

Explanatory information:

For minimum *cavity* widths for veneer and *cavity* masonry, see 3.3.4.2

Amdt 11

Figure 3.3.1.1
HEIGHT RESTRICTIONS FOR MASONRY WALLS INCLUDING GABLE ROOF

Note: Flat ceilings may act as lateral support to walls.

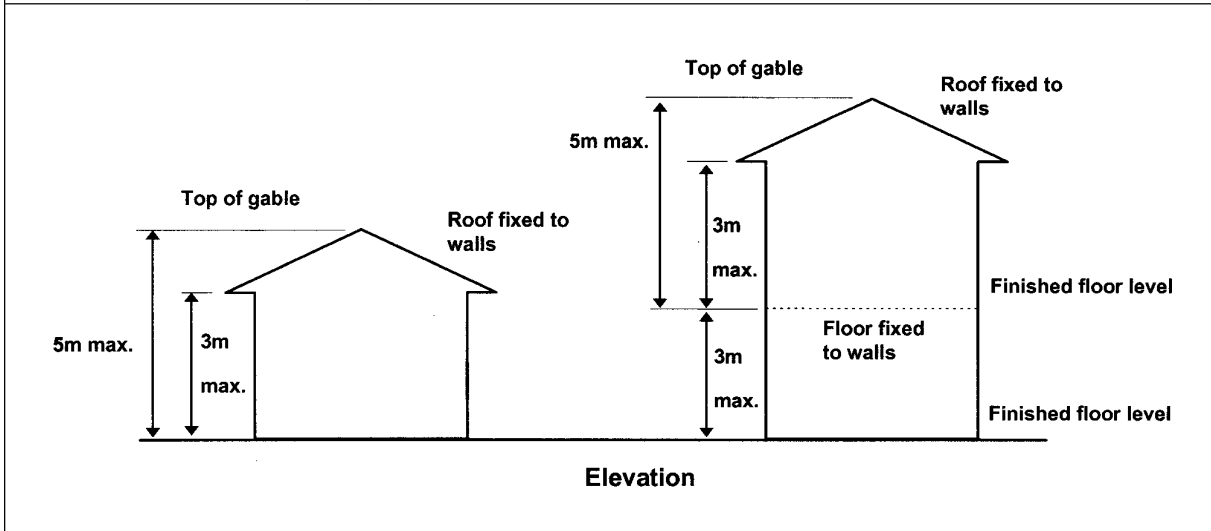

- (d) Unreinforced single leaf walls with *engaged piers* and return walls must comply with the relevant provisions of this Part and be constructed in accordance with the following:
- (i) The adjoining roof structure must be-
 - (A) connected to the *engaged piers*, (see Figure 3.3.1.2); or
 - (B) fixed to, or within 300 mm, of the return supports (see Figure 3.3.1.3).
 - (ii) Stack bonded piers must have wall ties at every 4th course.
 - (iii) Pier and return supports size limitations:
 - (A) Single-leaf *unreinforced masonry* walls with *engaged piers* must comply with Figure 3.3.1.2.
 - (B) Single-leaf *unreinforced masonry* walls with return supports must comply with Figure 3.3.1.3.
 - (iv) There must not be more than one opening per wall panel, and any opening must not be more than 900 mm high x 600 mm wide (see Figure 3.3.1.3).
 - (v) An *engaged pier* or return wall, must be provided at both sides of a door or full height window opening (see Figure 3.3.1.2).
 - (vi) Articulation joints must be located within 300 mm of vertical supports (see 3.3.1.8).

Fig 3.3.1.2
Amdt No. 3

**Figure 3.3.1.2
PIERS IN EXTERNAL SINGLE LEAF WALLS (not more than W41)**

Note: Piers are not required for 140 and 190 mm walls provided the roof structure is fixed to the walls at not more than 3.5 m centres to provide *lateral support* to the top of the walls.

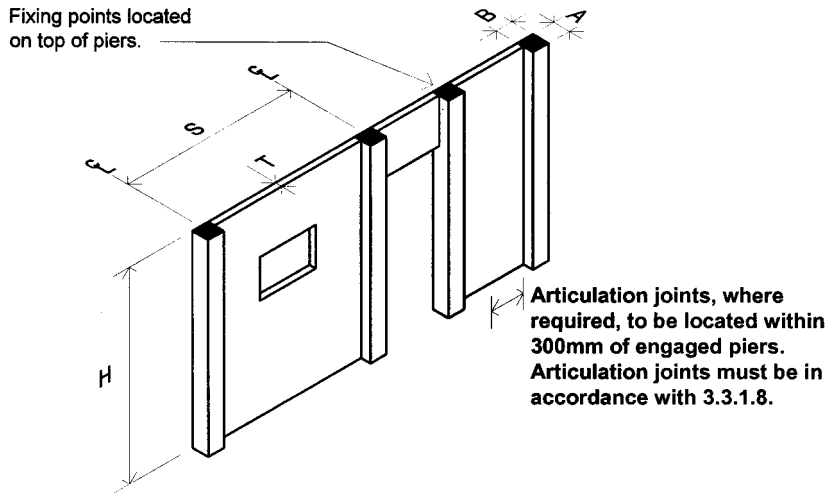

Thickness of wall (min.)		T	90	110	140	190
Pier size (min.)	Not more than W33	AxB	290x190	350x230	-	-
	Not more than W41	AxB	290x290*	350x350*	-	-
Spacing of piers (max.)		S	1650	1800	-	-
Height (max.)		H	2400	2700	2400	2700

* Piers in areas with a design wind speed of more than W33 must be vertically reinforced with at least 1/Y12, tied to the footing.

- (e) A Class 10a building containing not more than 1 storey may be enclosed with masonry *external walls* not less than 110 mm in thickness, provided that-
 - (i) the building measured in the direction of the span of the roof is not more than 9 m and the height is not more than 3 m; and

Amdt 11

3.3.1.2(e)
(v) and (vi)
Amdt No. 3

- (ii) piers are formed that are not less than 230 mm wide, project not less than 120 mm and are spaced at not more than 3 m centres; and
- (iii) the roof does not place any thrust onto the *external walls*; and
- (iv) cross walls are constructed at not more than 9 m centres; and
- (v) the Class 10a building is located in an area with a *design wind speed* of not more than W33; and
- (vi) the building is a design category H1 domestic structure in accordance with AS 1170.4.

STATE AND TERRITORY VARIATIONS

3.3.1.2(e) does not apply in NSW.

Amdt 11

Fig 3.3.1.3
Amdt No. 3

Figure 3.3.1.3
RETURN SUPPORTS LIMITATIONS FOR EXTERNAL SINGLE-LEAF WALLS
(for earthquake design category H1)

Note: Return supports are not required for 140 mm and 190 mm walls provided the roof structure is fixed at not more than 3.5 m centres to provide *lateral support* to the top of the walls.

Fixing points and articulation joints, where required, to be located within 300 mm of return walls. Articulation joints must be in accordance with 3.3.1.8.

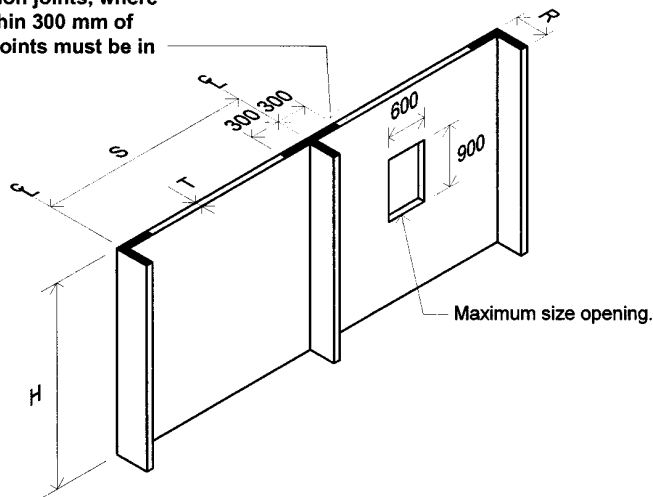

Thickness of wall (min.)	T	90	110	140	190
Return length (min.)	R	450	450	-	-
Spacing of returns (max.)	S	3000 (W33) 2500 (W41)	3700 (W33) 3000 (W41)	-	-
Height (max.)	H	2400	2400	2400	2700

3.3.1.3 Internal walls

Internal masonry walls must comply with the relevant provisions of this Part and be constructed as follows:

- (a) Internal masonry walls must be not less than 75 mm thick.
- (b) Where wall junctions occur they must be bonded or an articulation joint provided in accordance with 3.3.1.8.
- (c) Single leaf internal walls must be supported by either-
 - (i) the ceiling structure in accordance with Figure 3.3.1.4(a); or
 - (ii) return walls in accordance with Figure 3.3.1.4(b). A full height door frame or stud fastened at the ceiling framing and tied to the wall at 300 mm centres can be considered equivalent to a return wall.

Amdt 11

Figure 3.3.1.4
SUPPORT FOR INTERNAL WALLS (Dimensions in mm)

Diagram a. Supported by ceiling structure

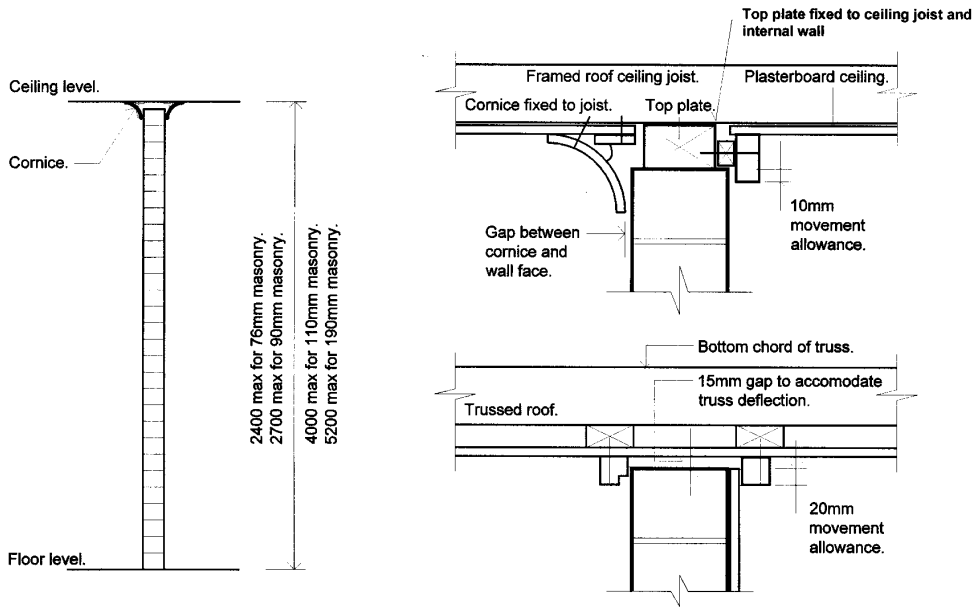
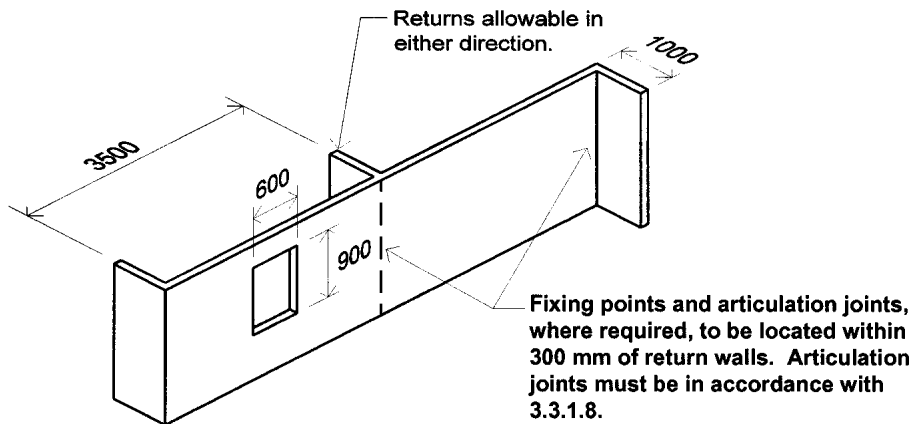

Fig 3.3.1.4 b
Amdt No. 3

Diagram b. Supported by return walls

Note:

1. An opening of not more than 600x900 mm is allowed to internal walls; and
2. The maximum allowable height for the wall is described in Diagram a.



3.3.1.4 Isolated piers

- (a) Isolated masonry piers supporting carports, verandahs, porches and similar roof structures, which form part of the main roof, or are attached to a wall of a Class 1 building must be not less than 290x290 mm and-
- (i) must be not more than 2.7 m high (see Figure 3.3.1.5); and
 - (ii) must be spaced at not more than 3 m centres (see Figure 3.3.1.5); and
 - (iii) must comply with the relevant parts of (b), (c) or (d); and
 - (iv) may also support a roller door.
- (b) Isolated piers supporting tiled roofs
- Isolated piers supporting tiled roofs must have a built-in 32x0.8 mm galvanised steel strap fixed to the roof structure and looped around a 10 mm diameter galvanised steel rod built into the pier not less than six courses below the top of the pier.
- (c) Isolated piers supporting sheet roofs must have-
- (i) a built-in 32x0.8 mm galvanised steel strap fixed to the roof structure and extending the full height of the pier which is looped around a 10 mm diameter galvanised steel rod cast into the footing when poured; or
 - (ii) a 10 mm diameter galvanised steel rod cast into the footing, threaded at the top and extending the full height of the pier.
- (d) Piers for a free standing carport must-
- (i) be not less than 290x290 mm with the central core filled with 20 MPa concrete, or an exposure class mortar (see Table 3.3.1.2) complying with 3.3.1.6; and
 - (ii) have the core reinforced with 1 Y12 steel reinforcing rod cast into the footing and extending the full height of the pier to connect to the roof structure.
- (e) Sub-floor isolated piers must comply with Figure 3.3.1.6.

Figure 3.3.1.5
ISOLATED PIERS UNDER MAIN ROOF

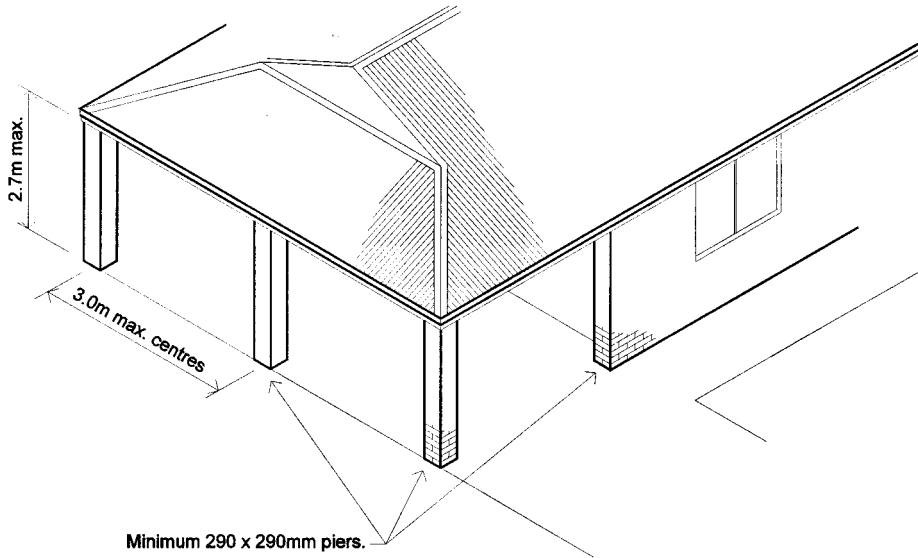

Amdt 11

Figure 3.3.1.6
SUB-FLOOR ISOLATED PIERS – MAXIMUM HEIGHTS

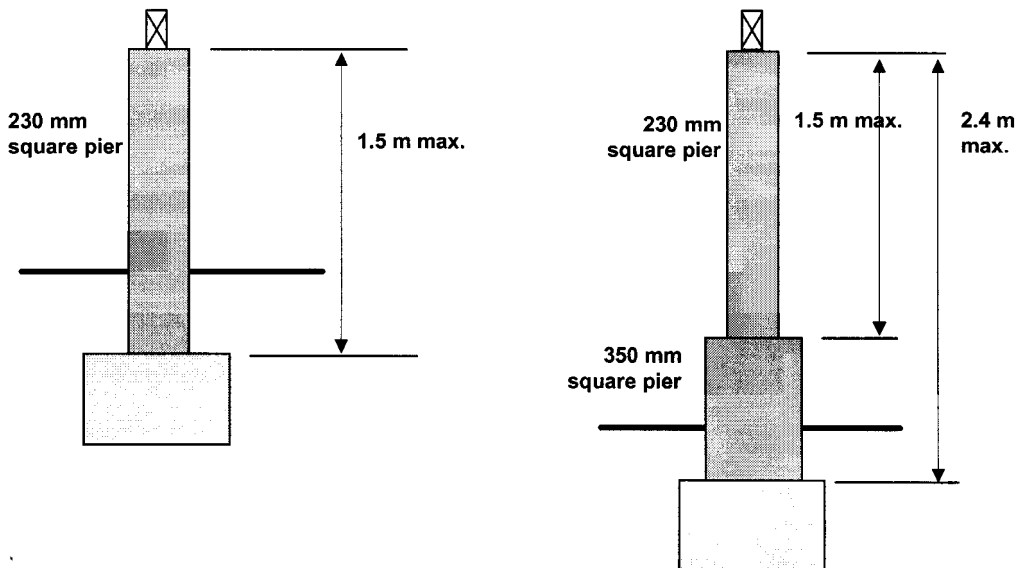

3.3.1.5 Masonry units

- (a) Mixing of clay with concrete or calcium silicate masonry panels for walling is not permitted; unless-
 - (i) at vertical junctions, a control joint is installed; and
 - (ii) at horizontal junctions, a slip joint using a membrane similar to that used for *damp-proof courses* is installed between the panels of the two different materials.
- (b) Masonry units must be classified and used in the exposure conditions appropriate to their classification as described in Table 3.3.1.1.

Table 3.3.1.1 EXPOSURE CONDITIONS	
CLASSIFICATION	APPLICATION
Protected (PRO)	Suitable for use above <i>damp-proof course</i> provided they are protected at the top of the wall by appropriate roofs, eaves, copings or toppings in- <ul style="list-style-type: none"> (a) internal walls; and (b) coated or rendered <i>external walls</i>
General purpose (GP)	Suitable for all uses except exposure class
Exposure Class (EXP)	Suitable for use in all classifications including severe local conditions such as: <ul style="list-style-type: none"> (a) Below the <i>damp-proof course</i> in areas where walls are expected to be attacked by salts in the ground water or brickwork itself (salt attack or salt damp). (b) On sea fronts where walls are exposed to attack from salt spray, or in heavily polluted areas subject to deposition of atmospheric pollution (further protection may be required in severe environments). (c) In retaining walls. (d) Under regular cyclic freeze and thaw conditions.

Amdt 11

3.3.1.6 Mortar mixes

Mortar used for masonry construction must-

- (a) comply with AS 3700; and
- (b) be mixed by volume in the proportions stated in Table 3.3.1.2; and
- (c) contain fine aggregate sand with low clay content and free from efflorescing salts; and
- (d) contain water which is potable (drinkable).

Table 3.3.1.2
MORTAR MIXES

Note: Additives may be used provided they comply with the appropriate specified rate.

BRICK CLASSIFICATION (as per Table 3.3.1.1)	MORTAR MIXED BY VOLUME Cement: Lime: Sand	
	General use	Suitable for concrete masonry - requires the use of methyl cellulose water thickener
Protected	1:2:9	1:0:5
General purpose	1:1:6	1:0:5
Exposure class	1:0.5:4.5	1:0:4

Amdt 11

3.3.1.7 Mortar joints

- (a) Unless otherwise specified masonry bed and *perpend* joints are to be a nominal 10 mm.
- (b) Where raked joints are used they must not be-
 - (i) deeper than 10 mm; or
 - (ii) used in saline environments or areas subject to heavy industrial air-borne pollution.

3.3.1.8 Vertical articulation joints

- (a) Vertical articulation joints must be provided in *unreinforced masonry* walls except walls built where the *site* soil classification is A or S (see Part 3.2.4).
- (b) Articulation joints must have a width not less than 10 mm and be provided (see Figure 3.3.1.7)-
 - (i) in straight, continuous walls having no openings, at not more than 6 m centres and not closer than the height of the wall away from corners; and
 - (ii) where the height of the wall changes by more than 20%, at the position of change in height; and
 - (iii) where openings more than 900x900 mm occur, at not more than 5 m centres, and positioned in line with one edge of the opening; and
 - (iv) where walls change in thickness; and
 - (v) at control or construction joints in footing slabs; and

- (vi) at junctions of walls constructed of different masonry materials; and
- (vii) at deep chases (rebates) for service pipes.

Figure 3.3.1.7
TYPICAL VERTICAL ARTICULATION JOINT LOCATIONS

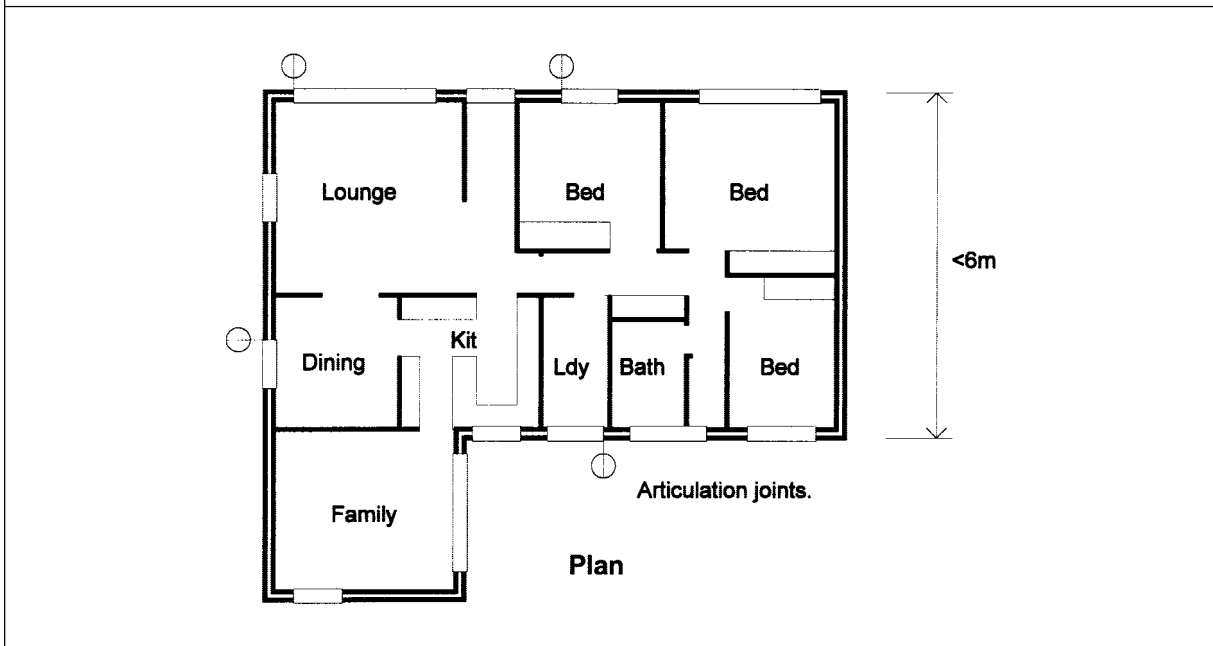

Amdt 11

- (c) For all articulation joints in *cavity* walls, extendable masonry anchors must be built in at every fourth course (see Figure 3.3.1.9). For veneer construction the extendable ties may be omitted.
- (d) Where articulation joints are adjacent to door or window frames, a 10 mm gap must be left between the edge of the frame and the masonry to allow for movement (see Figure 3.3.1.9).
- (e) For single leaf masonry walls stabilised by return walls, or *engaged piers*, any articulation joints must be within 300 mm of the vertical support (see Figures 3.3.1.3, and 3.3.1.4).
- (f) All joints in single skin masonry must be sealed with a flexible, compressible material (see Figure 3.3.1.9).
- (g) Articulation joints constructed adjacent to arched openings must be constructed with minimum abutments between the opening and the articulation joint, in accordance with the Cement and Concrete Association of Australia - Technical Note 61.

Explanatory information: Design for other masonry wall types

The above design criteria are typical for clay masonry construction. Alternative designs may be appropriate and consideration should be given to a number of important factors to achieve an effective system, including-

- (a) expected soil movement - based on soil engineer's report; and
- (b) expected masonry unit growth - based on manufacturer's specifications; and
- (c) construction of wall ie openings, length of wall, height.

For more detailed requirements of articulation joints, refer to the Cement and Concrete Association Construction Technical Note 61.

Amdt 11

Figure 3.3.1.8
TYPICAL LOCATIONS FOR ARTICULATION JOINTS

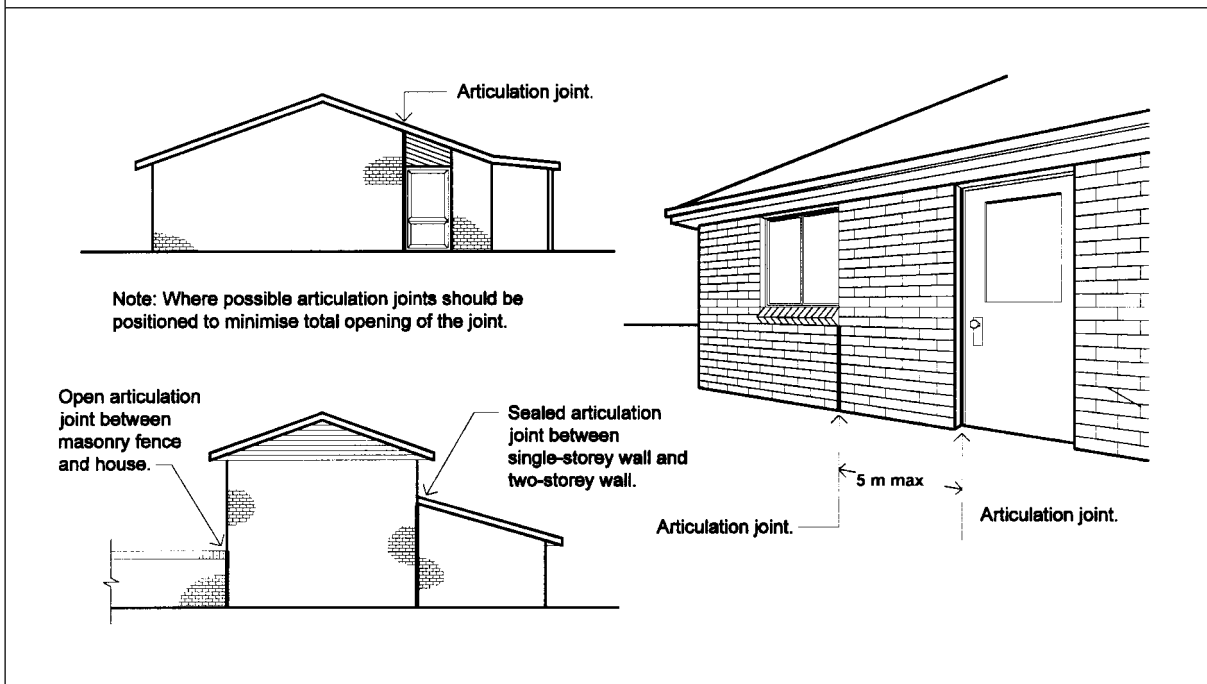
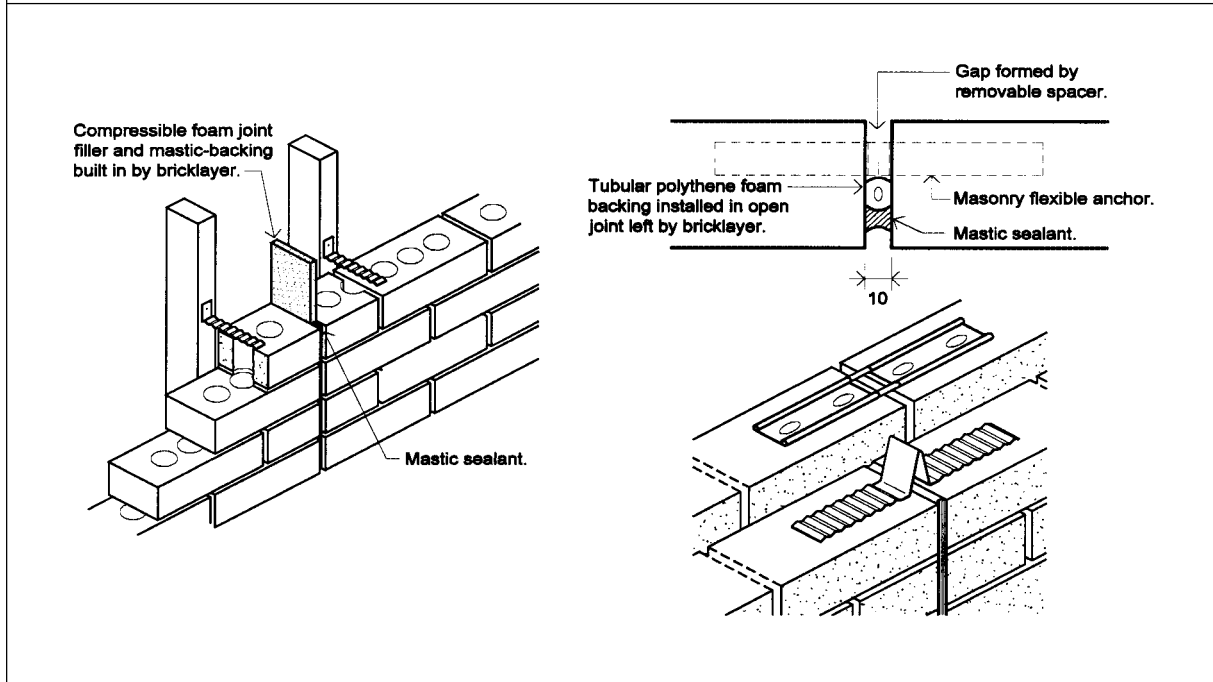

Figure 3.3.1.9
VERTICAL ARTICULATION JOINT DETAILS

Note: Mastic sealant is optional in cavity brick construction.



Amdt 11

3.3.1.9 Sub-floor ventilation

Ventilation under suspended floors must be in accordance with Part 3.4.1.

3.3.1.10 Shrinkage allowance for timber framing

- (a) In masonry veneer walls a gap must be left between the timber frame and the top of the masonry wall, including *window* sills etc, to allow for settlement of the timber framing caused by timber shrinkage. These clearances must be not less than-
- (i) 5 mm at sills or lower and single storey windows; and
 - (ii) 8 mm at roof overhangs of single storey buildings; and
 - (iii) 10 mm at sills of second storey windows; and
 - (iv) 12 mm at roof overhangs to two storey buildings.
- (b) The clearances described in (a) must be doubled if the timber framing is unseasoned hardwood.

PART 3.3.2 REINFORCED MASONRY

Appropriate Performance Requirements

Where an alternative *reinforced masonry* system is proposed to that described in Part 3.3.2, that proposal must comply with the structural *Performance Requirement* P2.1 in Section 2.

A. Acceptable construction manual

3.3.2.0 *Performance Requirement* P2.1 is satisfied for *reinforced masonry* if it is designed and constructed in accordance with AS 3700 Masonry Code.

Explanatory information:

Design requirements for other materials that may be used in combination with masonry (heavy steel support beams etc) are described in Part 3.11 - Structural design.

B. Acceptable construction practice

3.3.2.1 Application

Compliance with this Part satisfies *Performance Requirement* P2.1 for *reinforced masonry*, provided-

- (a) the *reinforced masonry* is constructed on footings that comply with Part 3.2; and
- (b) the building is located in an area with a *design wind speed* of not more than W41; and

Explanatory information:

- 1. Information on *design wind speeds* for particular areas may be obtained from the *appropriate authority*.
- 2. Masonry walls in an area with a *design wind speed* of more than W41 should be designed in accordance with AS 3700 or Part 3.10.1.

- (c) for earthquake design, the building is defined as a design category H1 or H2 domestic structure in accordance with AS 1170.4; and

Explanatory information:

- 1. This covers all *sites* except those identified by the site investigation as having soft soil (having a soil profile with more than 5 m of soft clay, loose sand, silt or uncontrolled fill) as defined by AS 1170.4.
- 2. For earthquake design H3, see AS 3700.

- (d) the building is not constructed in an *alpine area*.

3.3.2.2 External wall construction

3.3.2.2
Amdt No. 11

Reinforced masonry external walls must consist of masonry units complying with AS 3700 and constructed in accordance with the following (see also Figure 3.3.2.1):

- (a) The *external wall* thickness must not be less than 140 mm.
- (b) Tie down rods must be provided and be-
 - (i) not less than one Y12 steel reinforcing bar (or equivalent); and
 - (ii) spaced at not more than 1.8 m centres between openings; and
 - (iii) fully grouted into the block work with a grout having a characteristic compressive strength of 20 MPa; and
 - (iv) lapped with cogged steel starter bars of a size not less than the tie down rods, set 250 mm into the concrete edge beam or footing in accordance with Figure 3.3.2.1.

Amdt 11

Figure 3.3.2.1
TYPICAL FOOTING/TIE DOWN DETAILS

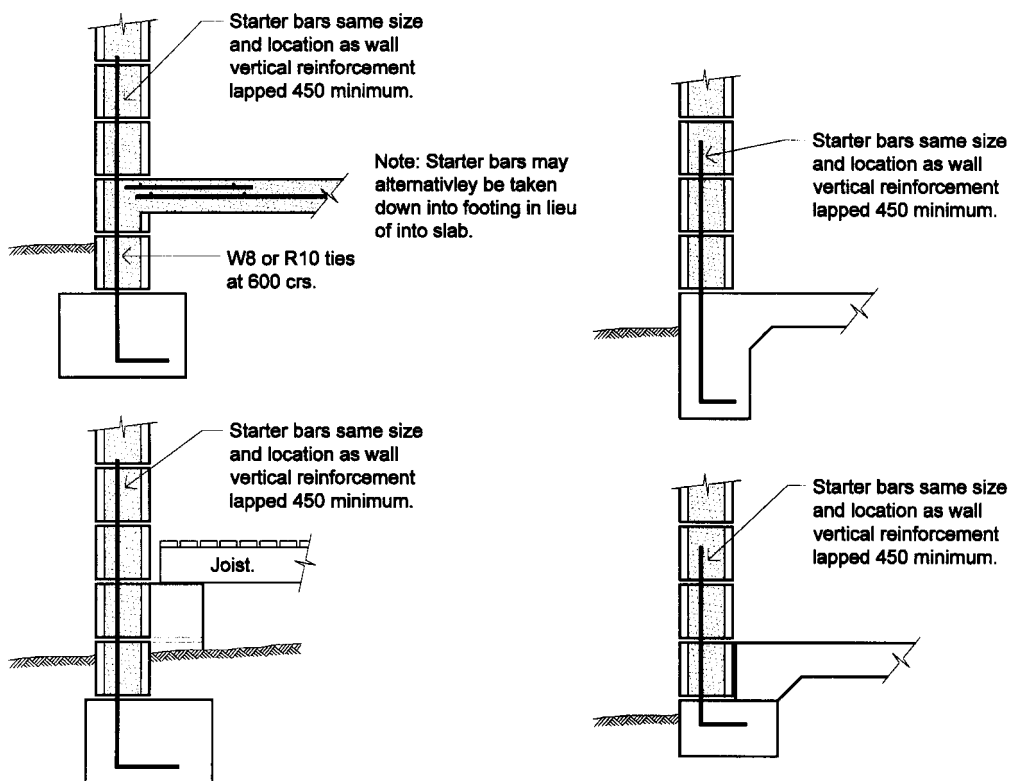

- (c) A continuous reinforced concrete *bond beam* must-
 - (i) be installed at the top of the walls in accordance with Figure 3.3.2.2 and Figure 3.3.2.3; and
 - (ii) have not less than two Y12 bars set in concrete grout with a characteristic compressive strength of 20 MPa; and
 - (iii) at door and *window* openings the *bond beam* may serve as a lintel supporting the roof trusses, provided additional reinforcement is placed in accordance with Figure 3.3.2.4; and
 - (iv) at first floor level a one course *bond beam* must be constructed in accordance with Figure 3.3.2.2.
- (d) All cores in masonry hollow block work below ground level must be filled with concrete grout.

Amdt 11

Figure 3.3.2.2
TYPICAL BOND BEAM DETAILS

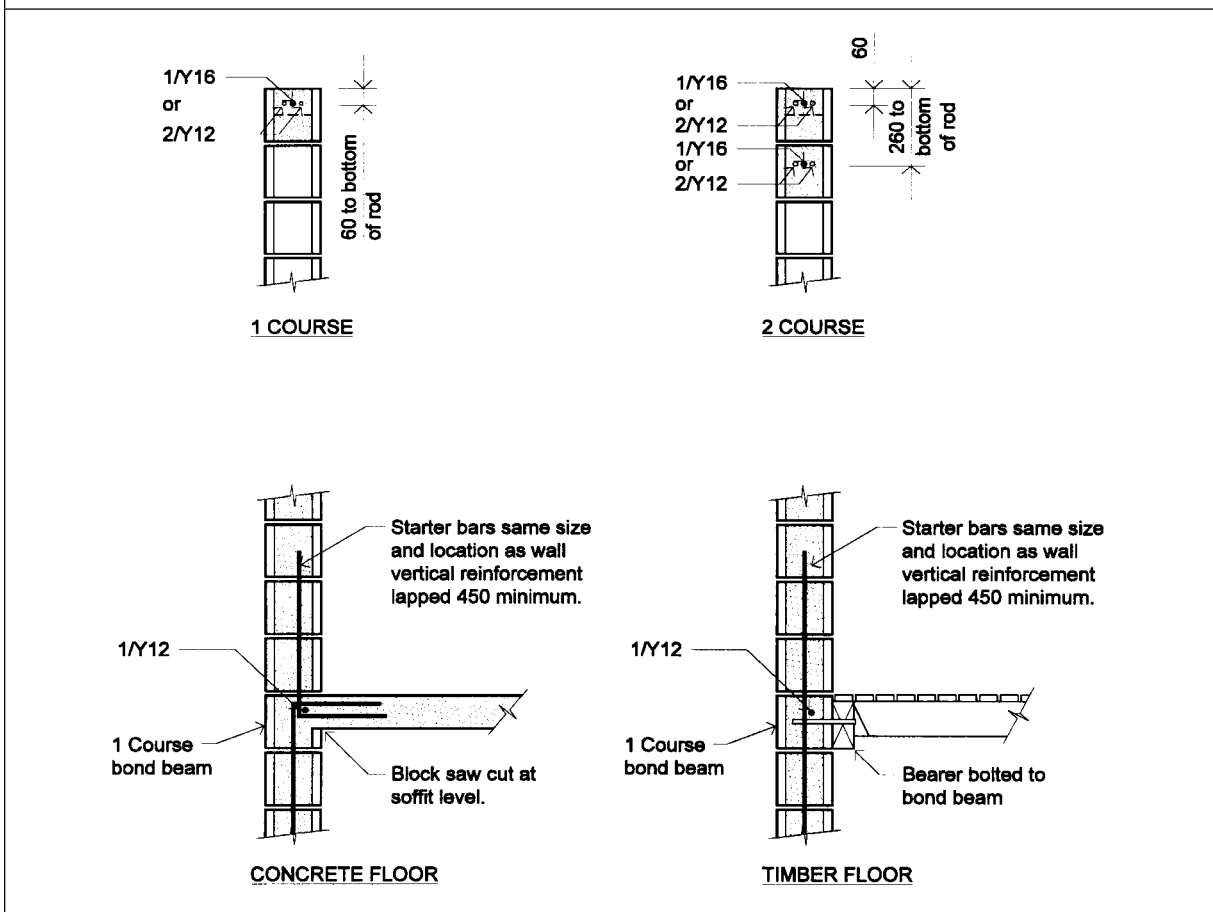

- (e) Lintels must be installed in accordance with the following:
 - (i) Lintels must be supported on reinforced piers in accordance with Table 3.3.2.1 (where appropriate).
 - (ii) Lintels carrying roof loads must be constructed in accordance with the appropriate requirements of Figure 3.3.2.3 and Figure 3.3.2.4.

**Table 3.3.2.1
ADDITIONAL WALL PIER REINFORCING**

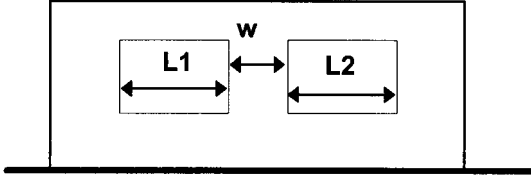

MAXIMUM SUM OF OPENINGS BESIDE PIERS "L1 + L2"				
ALL CORES REINFORCED WITH ONE Y12 ROD			END CORES ONLY REINFORCED WITH Y12 ROD	
WIDTH OF PIER "W" (mm)			WIDTH OF PIER "W" (mm)	
200	400	600	600	800
4000	6000	6000	6000	6000

Amdt 11

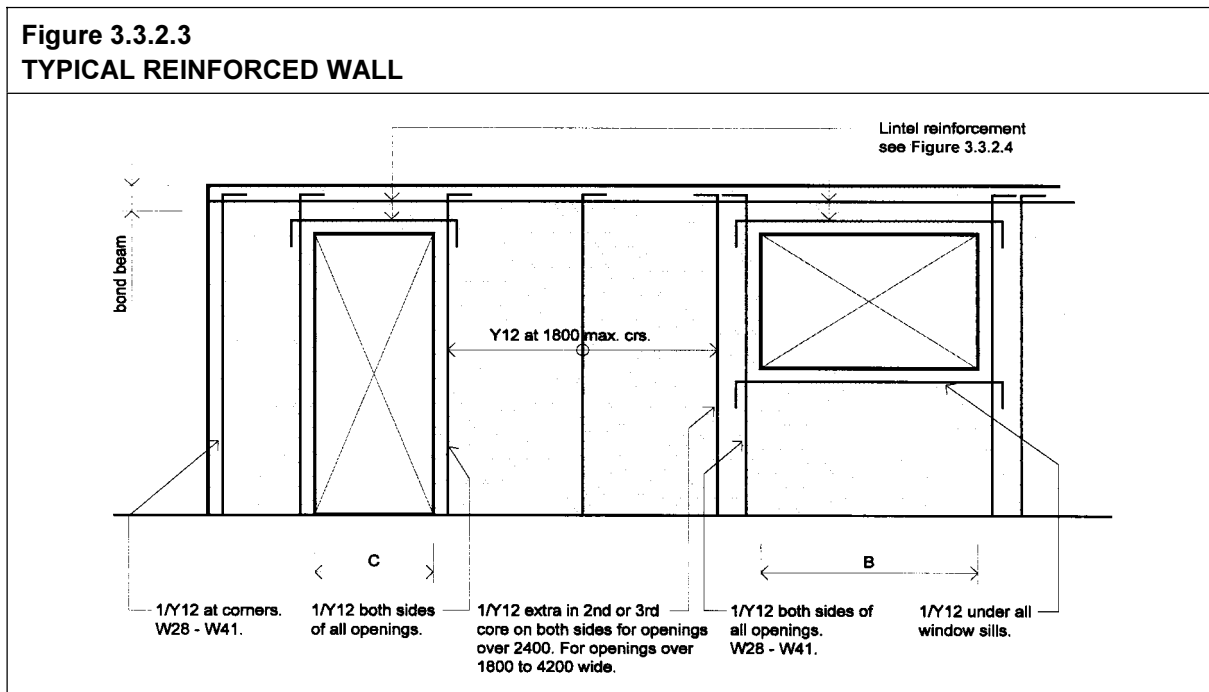

Figure 3.3.2.4
REINFORCEMENT AND CONSTRUCTION OF LINTELS

Diagram a. Lintel types

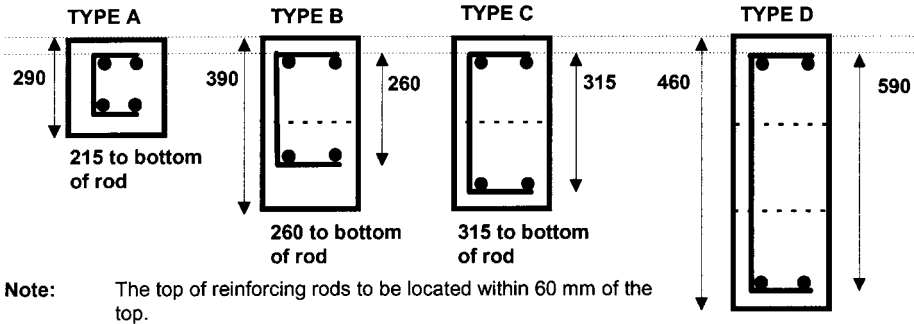

Table a. Reinforcement for lintel types

CODE				REINFORCEMENT	
A1	B1	C1	D1	2-Y12	Top and Bottom
A2	B2	C2	D2	1-Y16	Top and Bottom
A3S	B3S	C3S	D3S	2-Y12	Top and Bottom with W8 Stirrups @ 200 crs
A4S	B4S	C4S	D4S	1-Y16	Top and Bottom with W8 Stirrups @ 200 crs
A5	B5	C5	D5	2-Y16	Top and Bottom
A6S	B6S	C6S	D6S	2-Y16	Top and Bottom with W8 Stirrups @ 200 crs

Diagram b. Measurement of roof loads

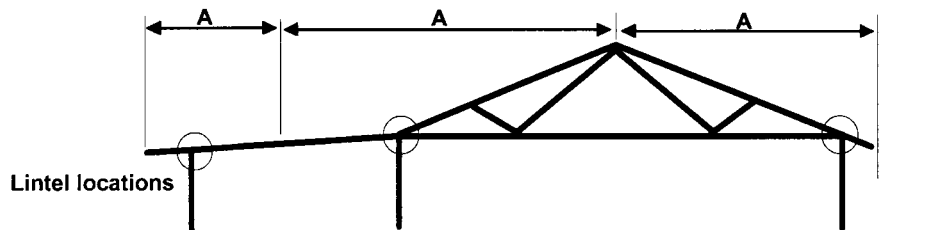

Table b. Lintel reinforcing for standard truss loading

Note: In lintels and bond beams using 2/Y12 bars, 1/Y16 bar may be used instead

OPENING (mm)	MINIMUM LINTEL REINFORCEMENT FOR STANDARD TRUSS LOADING								
	Maximum "A" – 4.6 m			Maximum "A" – 5.6 m			Maximum "A" – 6.6 m		
	LINTEL DEPTH (mm)			LINTEL DEPTH (mm)			LINTEL DEPTH (mm)		
	300	400	600	300	400	600	300	400	600
900	A1	B1 OR C1	D212	A1	B1 OR C1	D1	A1	B1 OR C1	D1
1200	A1	B1 OR C1	D212	A1	B1 OR C1	D1	A1	B1 OR C1	D1
1800	A1	B1 OR C1	D212	A1	B1 OR C1	D1	A3S	B1 OR C1	D1
2400	A1	B1 OR C1	D212	A3S	B1 OR C1	D1	A6S	B3S OR C1	D1
3000	A6S	B3S OR C1	D5	A6S	B6S OR C5	D1		B6S OR C66	D1
3600	-	B3S OR C5	D5		B6S OR C6S	D1		- C6S	D5
4200	-	- C6S	D5		- C6S	D5			D6
4800	-	- C6S	D5			D6			D6

Amdt 11

- (f) Bracing walls must be installed in buildings to control lateral loading in accordance with the following:
 - (i) The walls must be constructed in accordance with Figure 3.3.2.5.
 - (ii) The permissible bracing capacity is determined in accordance with Table 3.3.2.2 after considering Figure 3.3.2.6.

**Figure 3.3.2.5
TYPICAL BRACING WALL DETAILS**

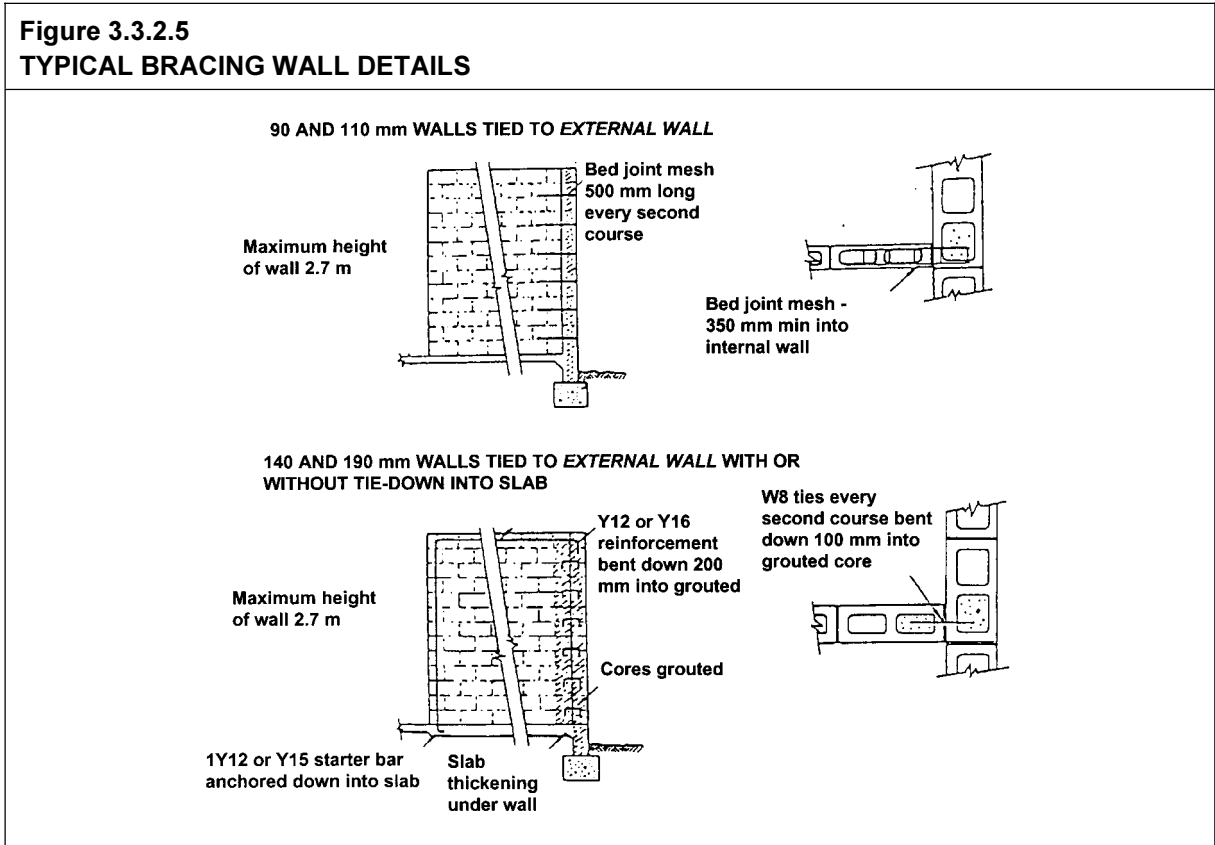

Amdt 11

**Figure 3.3.2.6
IDENTIFYING WALL LENGTHS – (To be used with Table 3.3.2.2)**

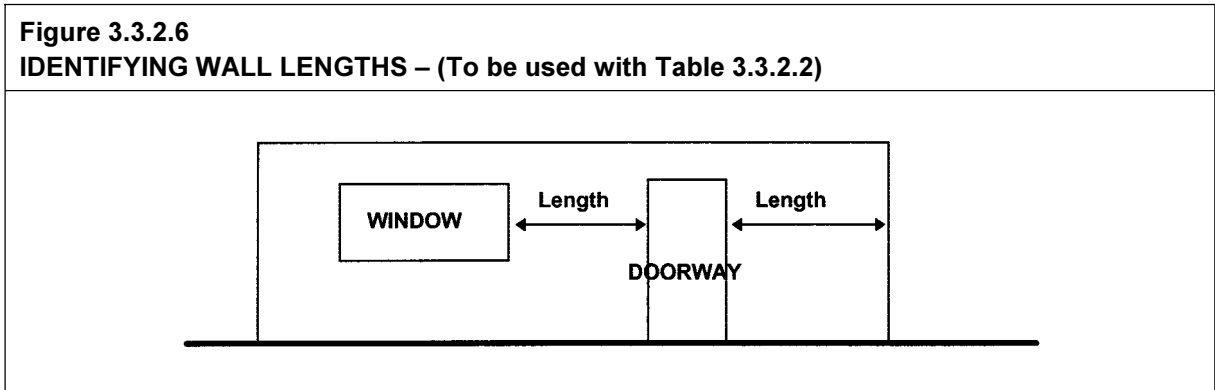

**Table 3.3.2.2
BRACING CAPACITY OF WALLS 2.7 m HIGH**

Note: Where a bracing wall is connected at only one end to a wall with a single course *bond beam*, the bracing value is limited by shear through the *bond beam* to 28.8 kN. Where it is necessary to use higher values a double *bond beam* must be used.

Wall Length (m)	PERMISSIBLE BRACING CAPACITY (kN)						
	90 mm & 110 mm Walls	140 mm Wall			190 mm Wall		
		No Tie down	Tie down size		No Tie down	Tie down size	
		Y12	Y16		Y12	Y16	
0.4	-	-	2.4	4.1	0.1	2.4	4.2
0.6	-	0.1	4.1	6.7	0.2	4.1	7.4
0.8	0.2	0.3	5.8	7.8	0.3	6.0	10.0
1.0	0.4	0.5	7.6	9.0	0.6	7.8	11.2
1.2	0.5	0.7	9.5	10.0	0.8	9.7	12.4
2.4	2.1	2.8	16.8	16.8	3.3	19.6	19.6
3.0	3.3	4.4	20.2	20.2	5.2	23.2	23.2
3.6	4.8	6.3	23.5	23.5	7.4	26.8	26.8
4.2	6.6	8.6	26.9	26.9	10.2	30.4	30.4
4.8	8.6	11.2	30.2	30.2	13.3	34.0	34.0
5.4	10.5	14.2	33.6	33.6	16.8	37.6	37.6
6.0	10.5	17.6	37.0	37.0	20.7	40.4	40.4

- (g) Roof trusses must be tied to the *reinforced masonry* wall with a method appropriate to the design strength nominated in Figure 3.3.2.7(a) or (b) after taking into consideration-
- (i) the uplift force as determined in accordance with Table 3.3.2.3; and
 - (ii) the net design uplift pressure as determined in accordance with AS 4055 or AS/NZS 1170.2.

Amdt 11

**Table 3.3.2.3
ROOF TRUSSES - UPLIFT FORCES**

DESIGN WIND SPEED	NET DESIGN UPLIFT PRESSURE (kPa)		NET DESIGN UPLIFT FORCE ON STANDARD TRUSS (kN)								
			TRUSSES AT 600 mm SPACING			TRUSSES AT 900 mm SPACING					
	TILE ROOF	SHEET ROOF	TILE ROOF			TILE ROOF			SHEET ROOF		
			DIMENSION "A" (m)			DIMENSION "A" (m)			DIMENSION "A" (m)		
			4.6	5.6	6.6	4.6	5.6	6.6	4.6	5.6	6.6
W33	0.00	0.42	0.0	0.0	0.0	0.0	0.0	0.0	1.7	2.1	2.5
W41	0.44	0.81	1.2	1.5	1.7	1.8	2.2	2.6	3.4	4.1	4.8

Note:

1. For a standard truss, the uplift force at each end is equal to the pressure multiplied by dimension "A" multiplied by the truss spacing.
2. Uplift forces for other values of dimension "A" may be interpolated.
3. Sheet roof includes metal tile.
4. Dimension "A" is determined in accordance with Figure 3.3.2.4 Diagram b.

Amdt 11

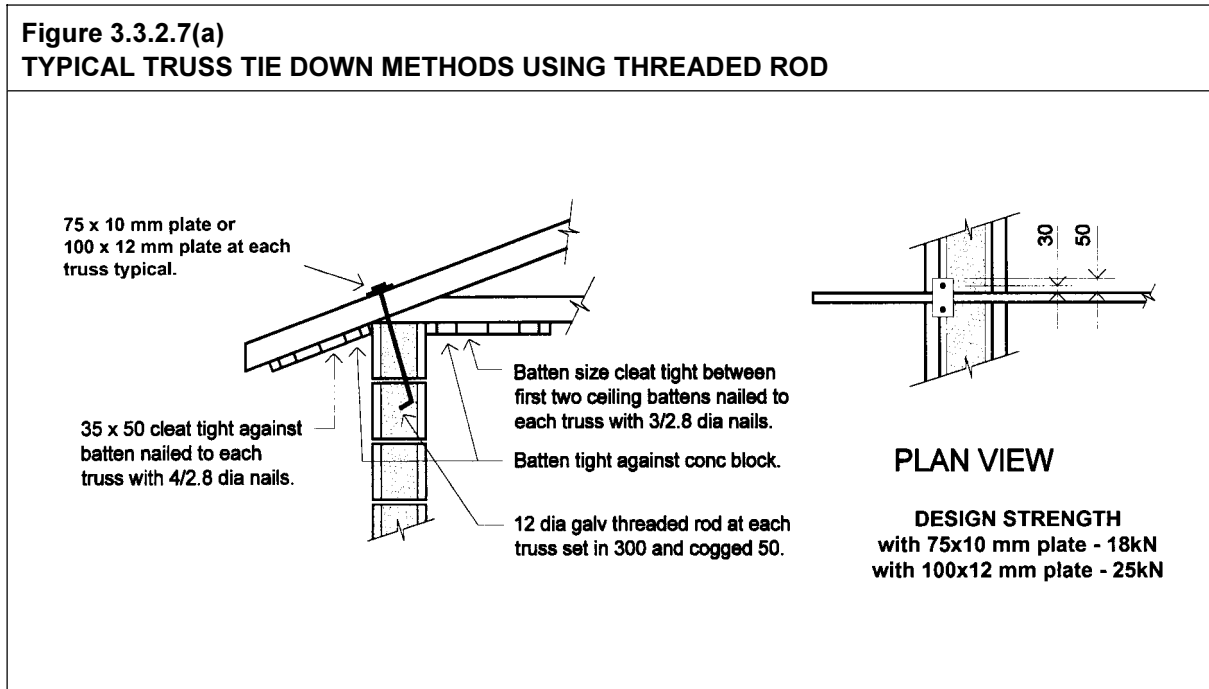
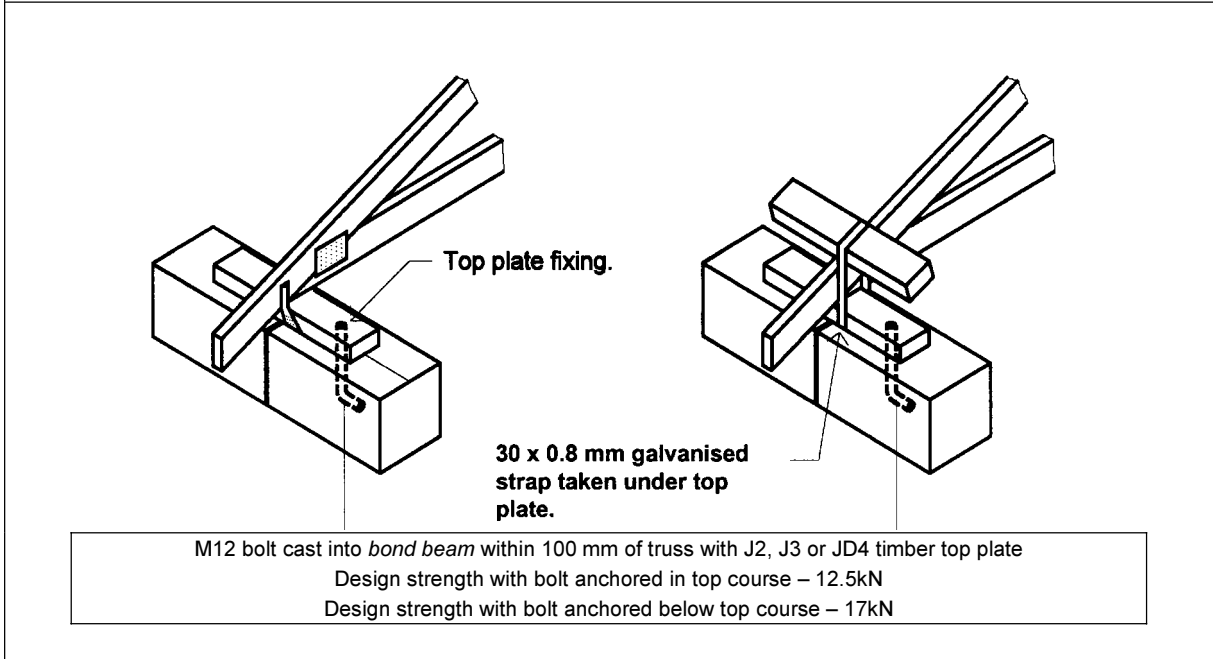

Figure 3.3.2.7(b)
TYPICAL TRUSS TIE DOWN METHODS – USING TOP PLATE



Amdt 11

Explanatory information:

Joint groups (J2, J3 and JD4) are a classification of the strength of a timber species for the purpose of joint design. Typically, mixed Australian grown softwoods are joint group JD4 and mixed hardwoods are joint group J2 or J3.

- (h) Gable ends to buildings must be constructed in accordance with one of the following:
 - (i) Where a timber frame is used above the *bond beam* the gable end must be supported by a ceiling diaphragm in accordance with Figure 3.3.2.8, Diagram a, by-
 - (A) anchoring the end truss to the wall; or
 - (B) bracing the end truss back to the internal trusses.
 - (ii) Where block work continues above the *bond beam*, fixed to the blockwork in accordance with Figure 3.3.2.8, Diagram b.

Figure 3.3.2.8
TYPICAL GABLE END CONSTRUCTION DETAILS

Diagram a. Timber frame above *bond beam*

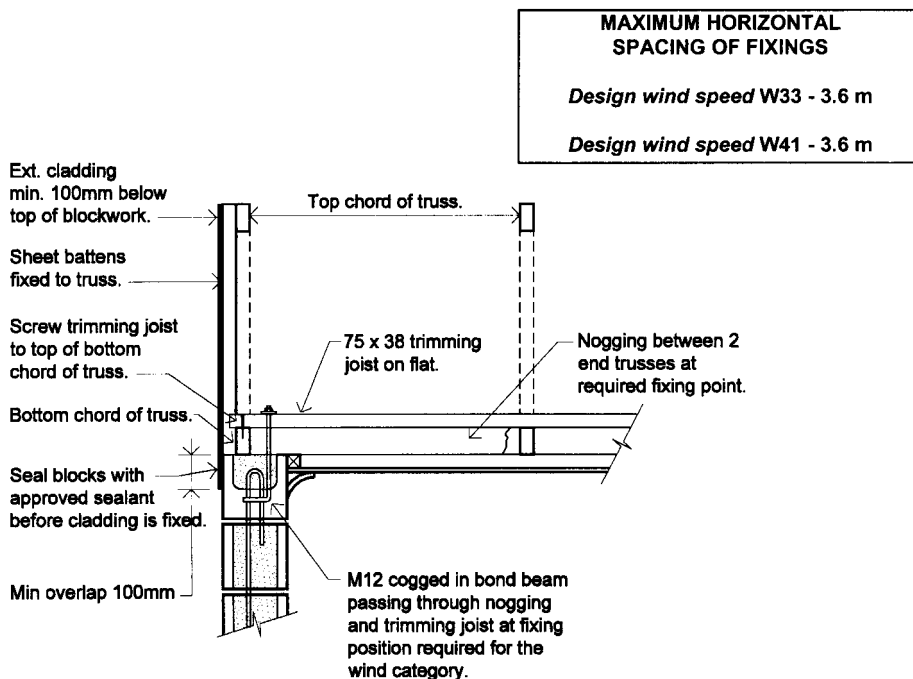
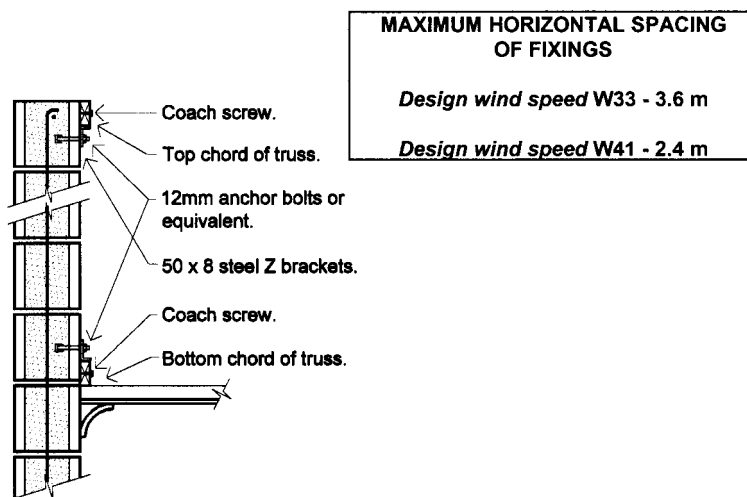

Diagram b. Blockwork above *bond beam*



Amdt 11

PART 3.3.3 MASONRY ACCESSORIES

Appropriate Performance Requirements

Where an alternative masonry accessory is proposed to that described in Part 3.3.3, that proposal must comply with *Performance Requirement P2.1* in Section 2.

A. Acceptable construction manual

3.3.3.0 *Performance Requirement P2.1* is satisfied for masonry accessories if they are constructed and installed in accordance with AS 3700 - Masonry Code.

B. Acceptable construction practice

3.3.3.1 Application

Compliance with this Part satisfies *Performance Requirement P2.1* for masonry accessories provided-

- (a) the building is located in an area with a *design wind speed* of not more than W41; and

Explanatory information:

1. Information on wind speeds for particular areas may be available from the *appropriate authority*.
2. Masonry walls in an area with a *design wind speed* of more than W41 must be designed in accordance with AS 3700.

- (b) for earthquake design, the building is defined as a design category H1 or H2 domestic structure in accordance with AS 1170.4; and

Explanatory information:

1. This covers all *sites* except those identified by the site investigation as having soft soil (having a soil profile with more than 5 m of soft clay, loose sand, silt or uncontrolled fill) as defined by AS 1170.4.
2. For earthquake design H3, see AS 3700.

- (c) The building is not constructed in an *alpine area*.

3.3.3.2 Wall ties

Amdt No. 7

- (a) Masonry wall ties must be used to connect-
- (i) masonry veneer wall cladding to a timber or metal *loadbearing* frame complying with Part 3.4; and
 - (ii) the two leaves of *cavity* masonry; and
 - (iii) two leaves of masonry forming a single wall with no *cavity*; and
 - (iv) intersecting masonry walls at a joint where course bonding is not employed.
- (b) Where articulation joints occur in masonry walls, ties must be built in both sides of the joint and spaced not more than 300 mm from the joint (see Figure 3.3.3.1).
- (c) Masonry wall ties must be installed in such a manner as to prevent moisture travelling along the tie to the inner leaf of masonry or frame.
- (d) Masonry veneer ties must be installed in accordance with Figure 3.3.3.1.
- (e) Wall ties must be classified in accordance with AS/NZS 2699.1 and installed as follows:
- (i) Light duty ties must only be used in veneer clad buildings in areas where the *design wind speed* is not more than W33, and must be spaced in accordance with Figure 3.3.3.1 as if for medium duty ties.
 - (ii) Medium duty ties must be-
 - (A) for veneer and *cavity* construction - spaced in accordance with Figure 3.3.3.1; and
 - (B) for solid or monolithic construction, in accordance with (f).
- (f) Ties for solid or monolithic construction must be medium duty classification spaced not more than 400 mm in each direction and-
- (i) the intersection of internal and external *cavity* or solid masonry walls must be bonded at the joint using medium duty ties at not more than 400 mm vertical spacing; and
 - (ii) in walls more than 200 mm in thickness, an additional tie is *required* within the spacing specified in (i) for every 200 mm of the thickness of the masonry units making the connection.
- (g) Masonry wall ties must be protected against corrosion in accordance with Table 3.3.3.1.

Amdt 11

Figure 3.3.3.1
TYPICAL BRICK TIES SPACINGS IN CAVITY AND VENEER CONSTRUCTION

Note:

1. Solid masonry ties must be of a size appropriate to the *cavity* width and built not less than 50 mm into each leaf.
2. Wall tie spacings indicated on the diagram are indicative and may be reduced according to nature of the wall.
3. Location of wall ties immediately adjacent to ties connecting an intersecting wall may be increased to not more than 600 mm away from the intersecting wall ties.

Diagram a. – Spacing for medium duty wall ties – cavity and veneer construction

Legend: For the purposes of this diagram:

-  Wall tie spacings halved
  Wall tie spacings as per Table a.

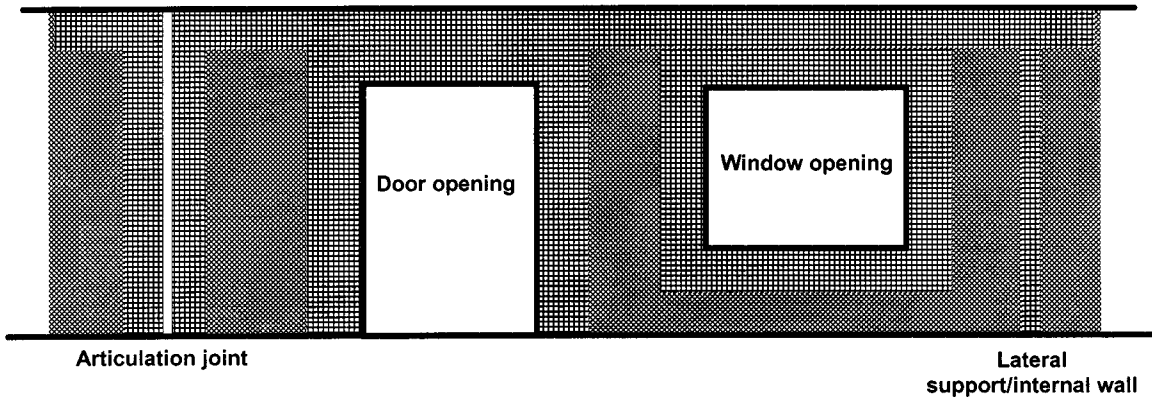

DESIGN WIND SPEED (non-cyclonic)	CAVITY MASONRY	MASONRY VENEER CONSTRUCTION	
		450 STUD WALLS	600 STUD WALLS
W28 – W41	600 x 600	600 x 450	600 x 600

Note:

1. Inner leaf masonry thickness 70 to 150 mm for *cavity* walls.
2. Around openings and at control joints, the vertical tie spacings are halved (ie the number of ties must be doubled).
3. In veneer construction, masonry must be tied to stud wall framing at all regular stud positions, including gable ends.

Amdt 11

Table 3.3.3.1
Amdt No. 6

Table 3.3.3.1 CORROSION PROTECTION FOR WALL TIES	
EXPOSURE CONDITION	TIE SPECIFICATION (minimum corrosion protection)
Areas- <ul style="list-style-type: none"> • less than 1 km from breaking surf; or • less than 100 m from salt water not subject to breaking surf; or • within heavy industrial areas. 	<ul style="list-style-type: none"> • Grade 316 or 316L stainless steel. • Engineered polymer.
Areas- <ul style="list-style-type: none"> • 1 km or more but less than 10 km from breaking surf; or • 100 m or more but less than 1 km from salt water not subject to breaking surf. 	<ul style="list-style-type: none"> • Sheet steel ties galvanised after manufacture - 470g/m² on each side. • Galvanised wire ties - 470g/m² coating mass.
All other areas.	<ul style="list-style-type: none"> • Ties manufactured from galvanised sheet steel - Z600. • Sheet steel ties galvanised after manufacture - 300g/m² on each side.

Expl. Info
Amdt No. 6

Explanatory information:

Wall ties that are suitable for use in a more severe exposure condition are also suitable for use in the less severe exposure conditions, i.e. stainless steel and engineered polymer ties are suitable for use in all conditions and 470g/m² galvanised ties can be used in all exposure conditions except the most severe.

3.3.3.3 Fixing straps and tie down systems

- (a) Timber door and *window* frames abutting masonry must be-
 - (i) fixed with 300 mm long 32x0.8 mm kinked galvanised steel straps; and
 - (ii) fixed to back of frames; and
 - (iii) set into courses not less than 150 mm at not more than 400 mm intervals.
- (b) For areas with a *design wind speed* of W28 or W33 and a roof system span of not more than 10 m, sheet metal and tiled roofs must be tied down using one of the following methods:
 - (i) 32x0.8 mm galvanised steel straps at not more than 1.2 m centres and corresponding with truss or rafter positions, looped around 10 mm diameter galvanised mild steel rods-
 - (A) built in across the *cavity* at a course not less than 900 mm below the top of the wall; and
 - (B) embedded not less than 50 mm into each leaf.

Amdt 11

- (ii) 25x1 mm galvanised steel straps at not more than 1.2 m centres and corresponding with truss or rafter positions, built into the masonry inner leaf not less than 50 mm and 900 mm below the top of the wall (see Figure 3.3.3.3).

Figure 3.3.3.3
SUITABLE TIE DOWN STRAP DETAILS

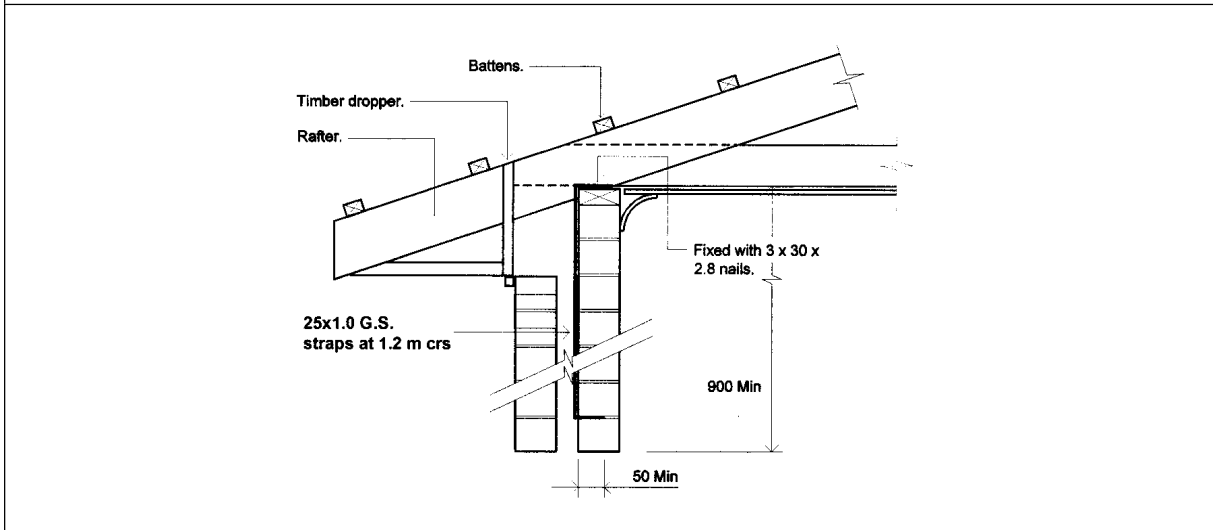

Amdt 11

3.3.3.4 Lintels

- (a) Lintels in masonry may be-
- (i) steel lintels complying with this Part; or
 - (ii) steel lintels complying with AS 4100, AS/NZS 4600; or
 - (iii) reinforced concrete beams designed in accordance with AS 3600.

Explanatory information:

Lintels that support structures other than masonry walls are covered in Section 3.4.4 - Structural steel members.

- (b) Steel lintels must comply with Figure 3.3.3.5 and-
- (i) the long leg of angles must be vertical (see Figure 3.3.3.4); and
 - (ii) each angle or flat can carry a maximum 110 mm wall thickness; and
 - (iii) the minimum bearing length at each end of the lintel must be-
 - (A) for clear spans less than 1 m - 100 mm; and
 - (B) for clear spans more than 1 m - 150 mm (see Figure 3.3.3.4); and

- (iv) there must be not less than three courses of brickwork over openings; and
 - (v) all loads must be uniformly distributed (point loads are not allowed).
- (c) Corrosion protection of lintels must be in accordance with Table 3.4.4.2.

3.3.3.4(c)
Amdt No. 3

Amdt 11

**Figure 3.3.3.4
LINTEL INSTALLATION**

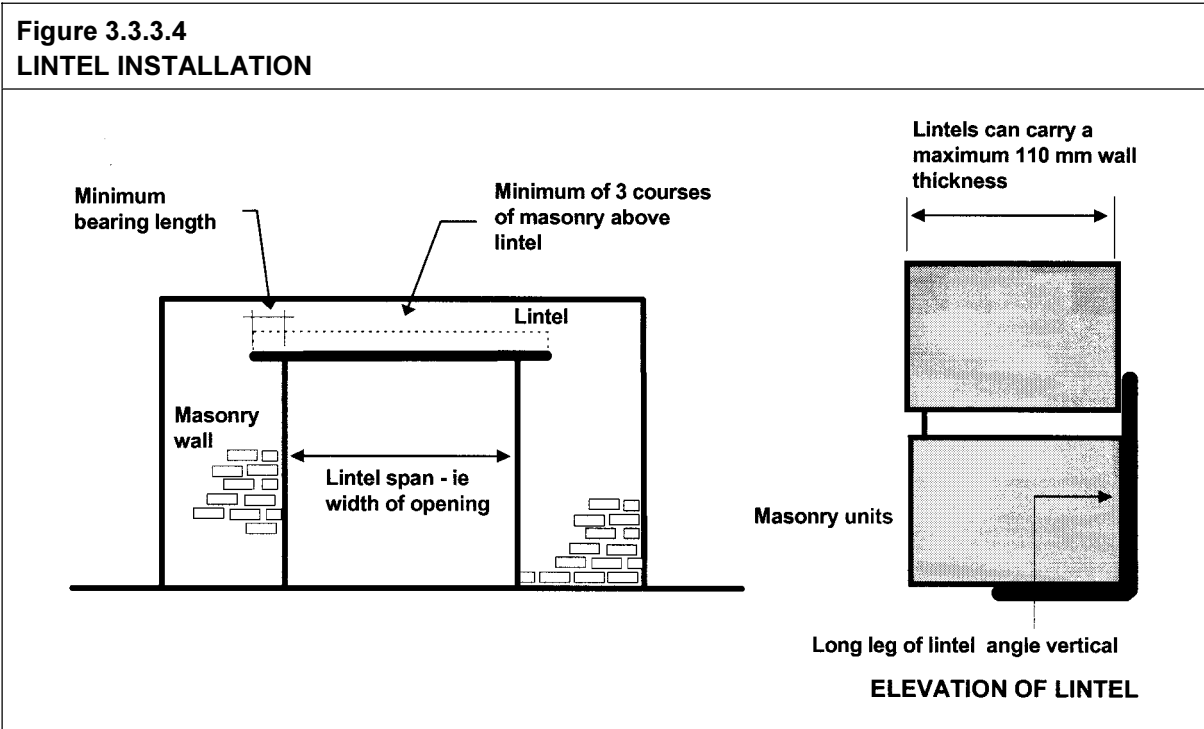

**Figure 3.3.3.5
LINTELS SUPPORTING ROOFS AND MASONRY WALLS**

Diagram a. – Lintel types as described in Table a.

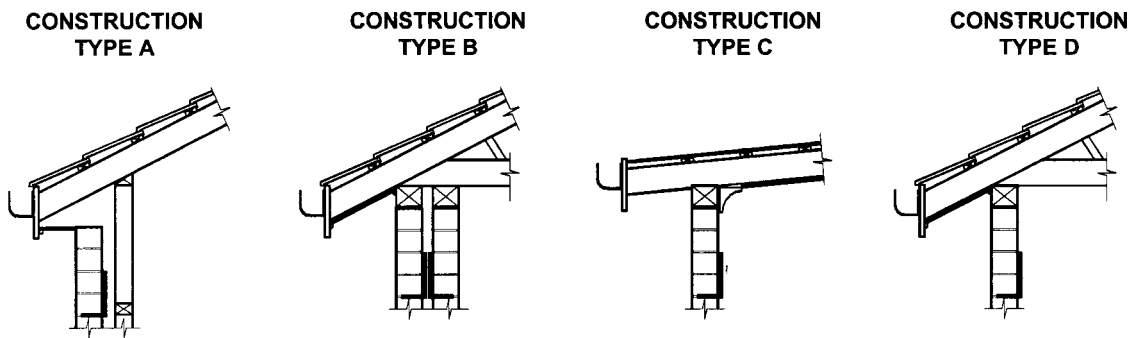

Table a. – Lintels spans

Design wind speed not more than W41 – Maximum roof span 10 m

Steel Section	Mass (kg/m)	Construction Type See Diagram a.			
		A	B	C	D
Angles		MAXIMUM CLEAR SPAN OF LINTEL (mm)			
90x90x6EA	8.22	3010	2050	2050	1570
90x90x8EA	10.6	3010	2170	2170	1810
100x100x6EA	9.16	3130	2290	2290	1810
100x100x8EA	11.8	3370	2410	2410	1930
150x90x8UA	14.3	4210	3370	3370	2770
150x100x10UA	18	4330	3490	3610	3010
Flats					
75x8	4.71	490	250	-	-
75x10	5.89	610	250	250	250

Amdt 11

PART 3.3.4 WEATHERPROOFING OF MASONRY

Appropriate Performance Requirements

Where an alternative waterproofing system is proposed to that described in Part 3.3.4, that proposal must comply with *Performance Requirement P2.2.2* in Section 2.

3.3.4 Application of this Part

3.3.4
Amdt No. 5

- (a) This Part applies to every external wall (including the junction between the wall and any window or door) of a Class 1 building.
- (b) This Part does not apply to any Class 10 building except where its construction contributes to the weatherproofing of the Class 1 building.

A. Acceptable construction manual

3.3.4.0 *Performance Requirement P2.2.2* is satisfied for weatherproofing of masonry if it is carried out in accordance with the appropriate provisions of AS 3700.

B. Acceptable construction practice

3.3.4.1 Application

Compliance with this Part satisfies *Performance Requirement P2.2.2* for weatherproofing of masonry, provided the masonry wall is constructed in accordance with Part 3.3.1 or Part 3.3.2.

3.3.4.2 Width of cavity

In brick veneer and *cavity* masonry construction, a *cavity* must be provided between the inner and outer walls as follows:

- (a) Brick veneer - not less than 25 mm width.
- (b) *Cavity* masonry - not less than 35 mm nor more than 65 mm width.
- (c) The minimum *cavity* width specified in (a) and (b) is to be maintained between the outer masonry leaf and any services, insulation, sheet bracing or other element located in the *cavity*.

3.3.4.3 Cavity ventilation and drainage

Open perpendicular joints (weepholes) must be created in the course immediately above any *DPC* or *flashing*-

- (a) at centres not exceeding 1.2 m; and
- (b) weepholes are not *required* for head or sill openings less than 1 m wide.

Fig 3.3.4.1
Amdt No. 11

Figure 3.3.4.1
LOCATION OF DPCs AND FLASHINGS IN SUB-FLOOR STRUCTURES

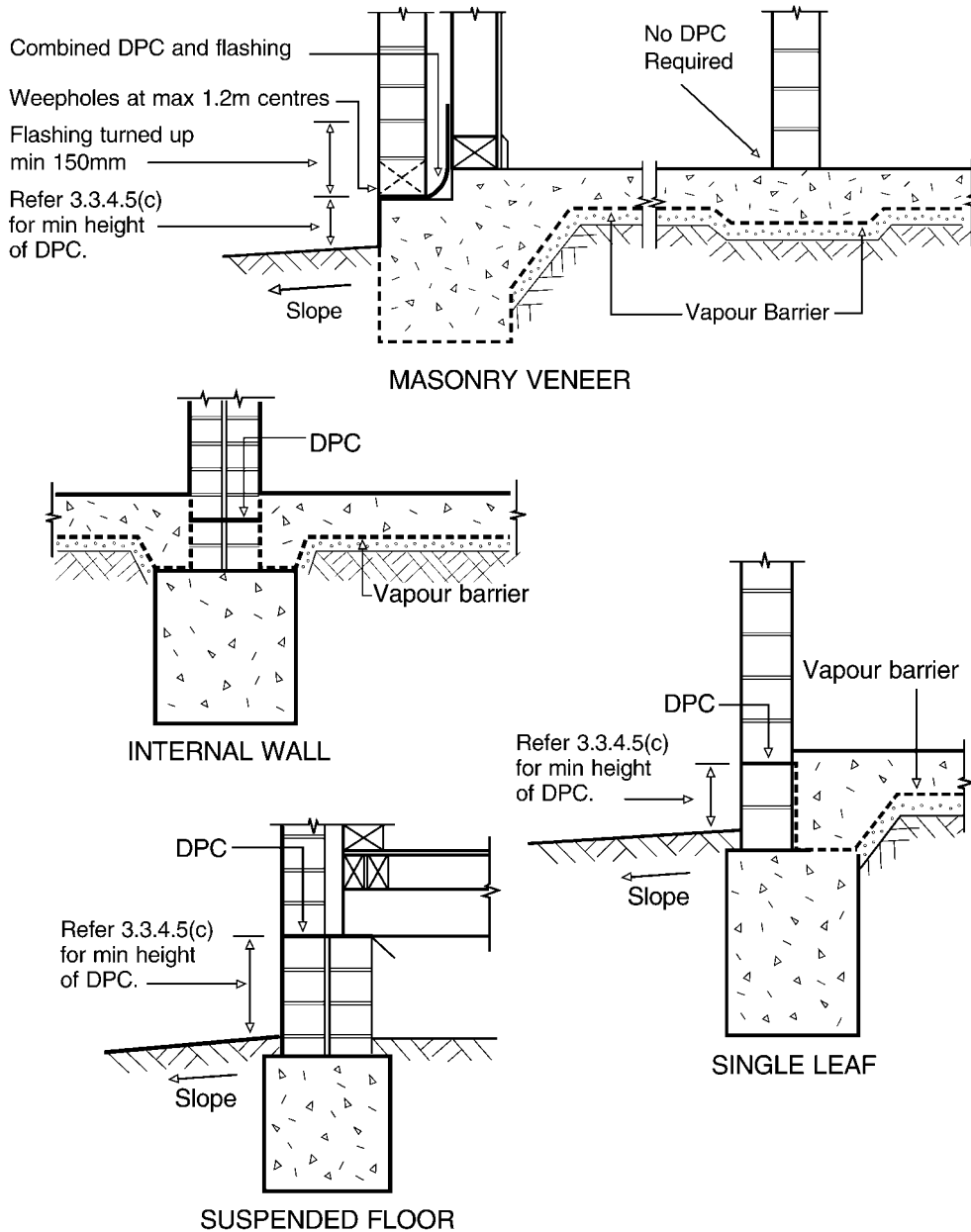

Amdt 11

3.3.4.4 Damp-proof courses – materials

Damp-proof courses must consist of-

- (a) a material that complies with AS/NZS 2904; or
- (b) embossed black polyethylene film of high impact resistance and low slip, with a nominal thickness of 0.5 mm prior to embossing, and meeting the requirements of clause 7.6 of AS/NZS 2904; or
- (c) polyethylene coated metal, that has an aluminium core of not less than 0.1 mm thick, is coated both sides with bitumen adhesive enclosed in polyethylene film of not less than 0.1 mm thick on each face, and has a nominal total thickness of not less than 0.5 mm prior to embossing; or
- (d) bitumen impregnated materials of not less than 2.5 mm thickness, that meet the requirements of clause 7.5 of AS/NZS 2904, when used in walls which are not higher than 7.8 m above the level of the *DPC*; or
- (e) termite shields (with no penetrations) continuous through the wall or pier.

Amdt 11

SA var.
Amdt No. 11

STATE AND TERRITORY VARIATIONS

In South Australia delete 3.3.4.4 and insert SA 3.3.4.4 as follows:

SA 3.3.4.4 Damp-proof courses - materials

Damp-proof courses and *flashings* used as *DPC*'s must consist of-

- (a) embossed black polyethylene film meeting the requirements of clause 7.6 of AS/NZS 2904; or
- (b) polyethylene coated aluminium meeting the requirements of clause 7.4 of AS/NZS 2904; or
- (c) bitumen impregnated materials of not less than 2.5 mm thickness, meeting the requirements of clause 7.5 of AS/NZS 2904, when used in walls not higher than 7.8 m above the level of the *damp-proof course*.

3.3.4.5 Damp-proof courses – installation

Amdt No. 11

- (a) *DPC*s must be-
 - (i) located in accordance with Figure 3.3.4.1 to form a continuous damp-proofing barrier around the building; and-
 - (ii) of sufficient width to extend through the entire width of the masonry leaves.
- (b) A *flashing* that extends through the entire width of the masonry leaves may also be used as a *DPC* (see Figure 3.3.4.1).

- (c) The height of a *DPC*, or *flashing* serving as a *DPC*, (see Figure 3.3.4.1) must be not less than-
- (i) 150 mm above the adjacent ground level; or
 - (ii) 75 mm above the finished surface level of adjacent paved, concreted or landscaped areas that slope away from the wall (see Figure 3.3.4.1); or
 - (iii) 50mm above finished paved, concreted or landscaped areas complying with 3.1.2.3(b)(iii) and protected from the direct effects of the weather by a carport, verandah or the like.

Expl. Info
Amdt No. 11

Explanatory information:

150 mm clearance between the *DPC* and adjacent ground level reduces the risk of the effectiveness of the *DPC* being affected by changes in the surface level. Where changes in surface level are less likely to occur, such as where the adjacent surface is finished with paving, concreting or landscaping, the height of the *DPC* above that surface may be reduced to 75 mm. When also protected from the weather by a carport, verandah or the like the height of the *DPC* may be reduced to 50mm.

- (d) Masonry units and mortar below the lowest *DPC* must be of the appropriate classification for the exposure condition (see Table 3.3.1.1 and Table 3.3.1.2).
- (e) *DPCs* may be stepped where a change in floor level occurs.
- (f) *DPCs* must be installed under the coping to parapets where the parapet is more than 300 mm above the adjoining roof cladding (see Figure 3.3.4.2).
- (g) In chimney stacks-
- (i) the *DPC* must be installed between 150 mm and 300 mm above the highest point where the chimney meets the roof; or
 - (ii) two *DPCs* may be used to avoid a high *flashing* upstand (see Figure 3.3.4.3).
- (h) Lap joints in a *DPC* must be not less than 150 mm.

Expl. Info
Amdt No. 11

Explanatory information:

A *DPC* is used to prevent the penetration of water and moisture into a building. As a result, careful consideration must be given to the location of a *DPC* and its intended use. In addition to the provision of this clause, termite risk management in accordance with Clause 3.1.3 may also need to be considered when determining the appropriate location of the *DPC*.

SA var.
Amdt No. 11

STATE AND TERRITORY VARIATIONS

In South Australia delete 3.3.4.5(b) and insert SA 3.3.4.5(b) as follows:

- (b) A *flashing* that extends through the entire width of the masonry leaves and complies with SA 3.3.4.4 may also be used as a *DPC*.

Amdt 11

Fig 3.3.4.2
Amdt No. 11

Figure 3.3.4.2
INSTALLATION OF DPCs AND FLASHINGS FOR PARAPET WALLS

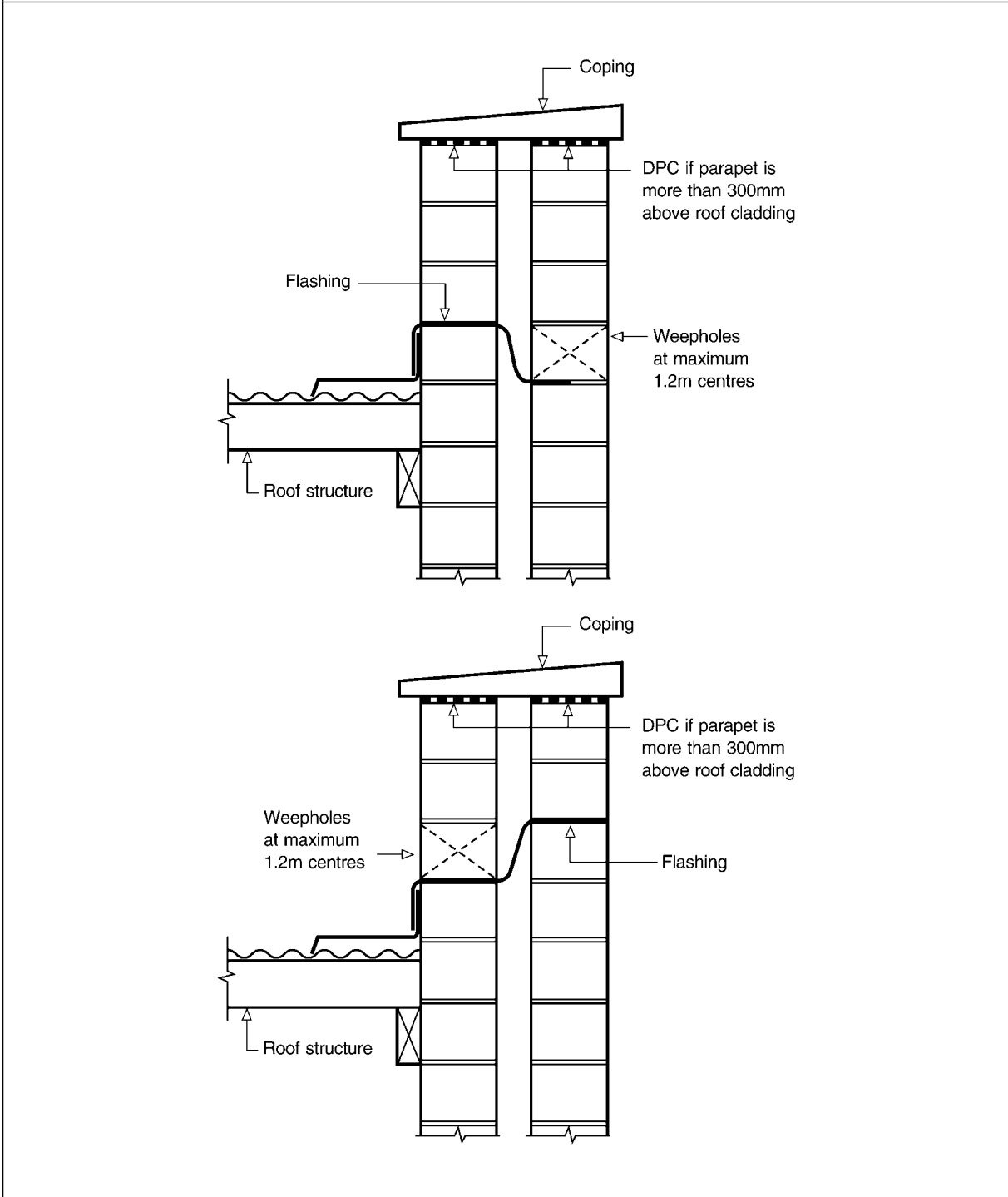

Amdt 11

Fig 3.3.4.3
Amdt No. 11

Figure 3.3.4.3
INSTALLATION OF DPCs AND FLASHINGS FOR CHIMNEYS

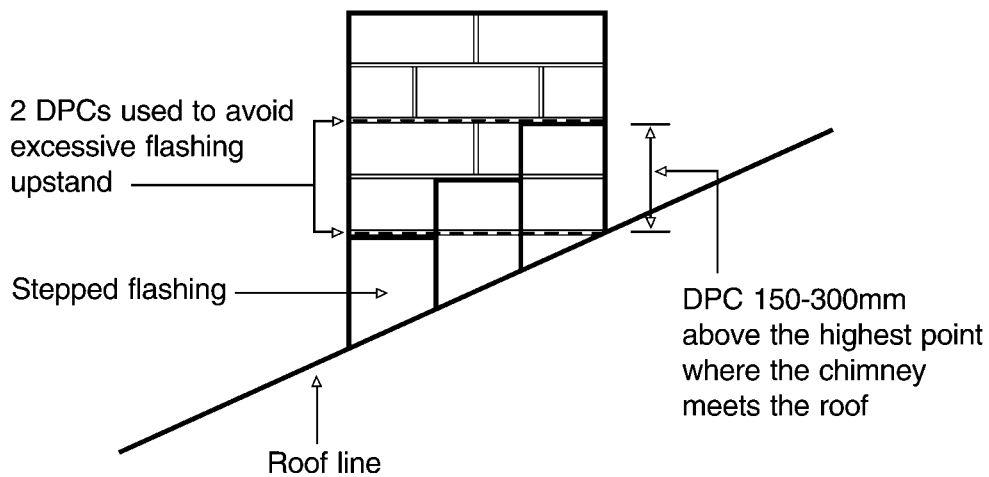
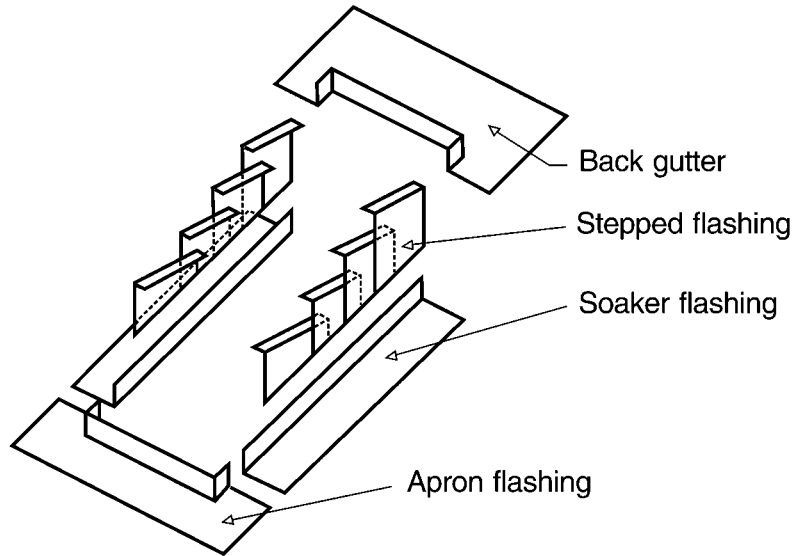

Amdt 11

3.3.4.6 Flashings

Amdt No. 11

Flashings materials must comply with AS/NZS 2904 or Table 3.3.4.1 and-

- (a) be built in as the work proceeds; and
- (b) where electrolytic action could otherwise occur, different materials must be isolated in accordance with Table 3.5.1.2.

SA var,
Amdt No. 11

STATE AND TERRITORY VARIATIONS

In South Australia delete 3.3.4.6 and insert SA 3.3.4.6 as follows:

SA 3.3.4.6 Flashings

- (a) *Flashing* materials (except where used as a *DPC*) must comply with AS/NZS 2904 or Table 3.3.4.1 and-
 - (i) be built in as the work proceeds; and
 - (ii) where electrolytic action could otherwise occur, different materials must be isolated in accordance with Table 3.5.1.2.
- (b) *Flashings* used as *DPCs* must comply with SA 3.3.4.4.

Amdt 11

Table 3.3.4.1
Amdt No. 11

Table 3.3.4.1 SUITABLE FLASHING MATERIALS FOR CONCEALED AND EXPOSED LOCATIONS	
LOCATION	SUITABLE FLASHING MATERIAL
CONCEALED (e.g. <i>cavity flashing</i>)	<ul style="list-style-type: none"> • Uncoated annealed lead having a mass of not less than 10 kg/m². • Uncoated copper having a mass of not less than 2.8 kg/m² and having a thickness of 0.3 mm to 0.5 mm. • Bitumen coated metal (normally aluminium) with a total coated thickness of 0.6 to 1.00 mm. • Zinc coated steel with a thickness of not less than 0.6 mm. • Embossed/Quilted polyethylene sheet with an average thickness of not less than 0.5 mm.
EXPOSED (e.g. roof to masonry wall <i>flashings</i>)	<ul style="list-style-type: none"> • Uncoated annealed lead having a mass of not less than 20 kg/m² in lengths not exceeding 1.5 m. • Uncoated copper having a mass of not less than 2.8 kg/m² and having a thickness of 0.3 mm to 0.5 mm. • Bitumen coated metal (normally aluminium) with a total coated thickness of 0.6 to 1.00 mm • Zinc coated steel with a thickness of not less than 0.6 mm

Fig. 3.3.4.4
Amdt No. 11

Figure 3.3.4.4
PROTECTION OF OPENINGS IN EXTERNAL WALLS

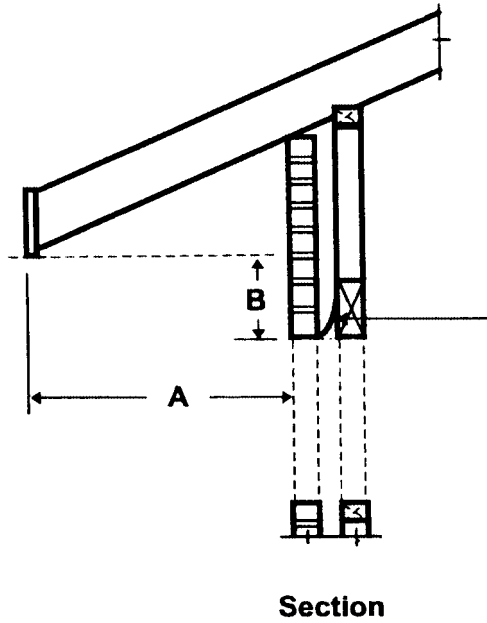

Flashing to an opening may be omitted if A is not less than 3 x B for a top flashing and for a sill flashing B is measured down to the bottom of the opening.

Amdt 11

Fig 3.3.4.5
Amdt No. 11

Figure 3.3.4.5
INSTALLATION OF SILL AND HEAD FLASHINGS

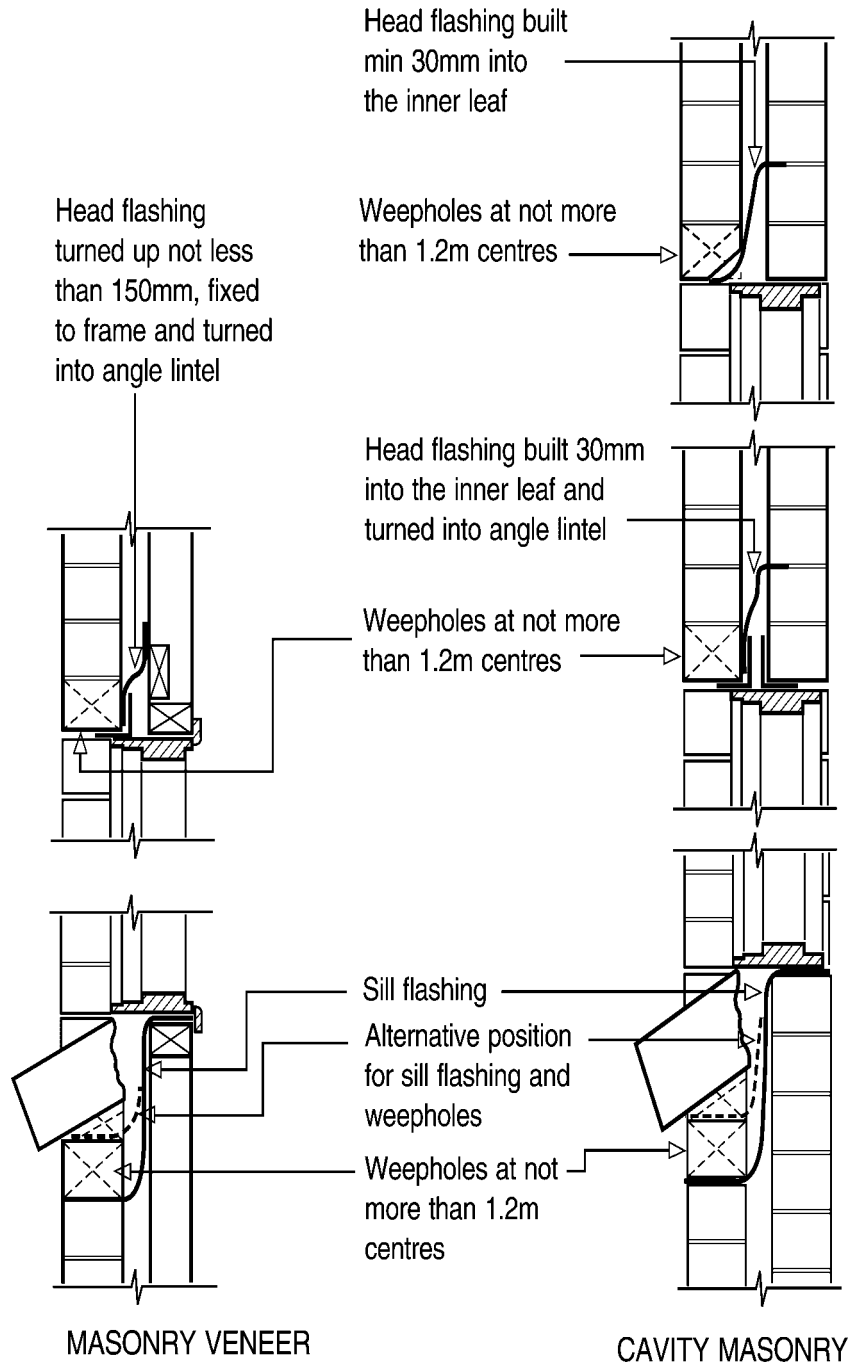

Amdt 11

Fig 3.3.4.6
Amdt No. 11

Figure 3.3.4.6
INSTALLATION OF FLASHINGS AT ROOF/WALL JUNCTIONS

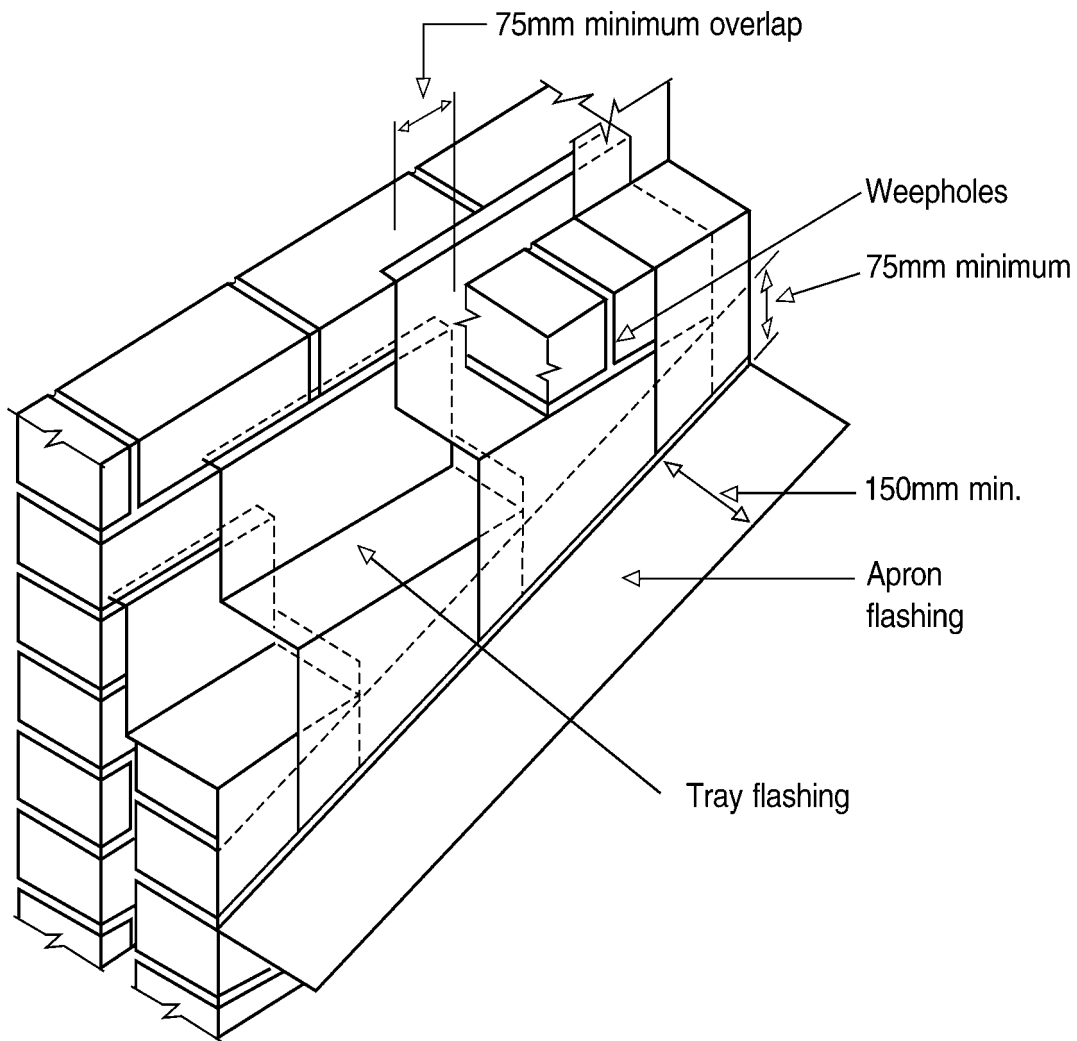

Amdt 11

Figure 3.3.4.7
STEPPED CAVITY FLASHINGS

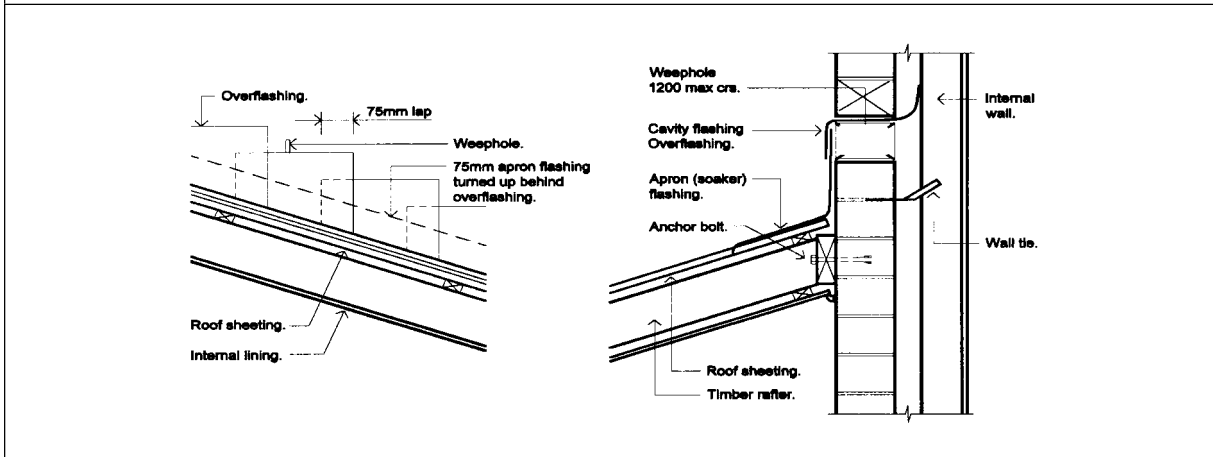

Amdt 11

3.3.4.7 Location of flashings

3.3.4.7 A flashing must be provided-

Amdt No. 11

- (a) where the *cavity* of a *cavity* masonry or masonry veneer wall is interrupted by a structural element (other than a wall tie), opening or the like; and
- (b) within the *cavity* where a roof abuts a *cavity* wall and an external masonry leaf or veneer becomes a wholly or partly internal wall; and
- (c) from an external masonry leaf or veneer onto an abutting roof; and
- (d) at the base of a *cavity* where there is no other means of dispersing water from within the *cavity*; and
- (e) from a masonry chimney onto the abutting roof.

3.3.4.8 Flashings at the base of cavity walls

A flashing at the base of a *cavity* masonry or masonry veneer wall-

Amdt No. 11

- (a) in masonry veneer construction, must extend across the *cavity* and be turned up not less than 150 mm and fixed to the frame; and
- (b) in *cavity* masonry construction, must extend across the *cavity* and be turned up not less than 150 mm and built 30 mm into the inner masonry leaf; and
- (c) must have a continuous fall towards the outer leaf or veneer.

3.3.4.9 Sill and head flashing

(a) A flashing above (head flashing) and below (sill flashing) an opening in a *cavity* wall-

3.3.4.9
Amdt No. 11

- (i) must extend not less than 100 mm past each side of the opening; and
- (ii) must extend across the *cavity* and have a continuous fall towards the outer leaf or veneer.

- (b) A head *flashing*-
 - (i) in masonry veneer construction, must be turned up not less than 150 mm and fixed to the frame; and
 - (ii) in *cavity* masonry construction, must be turned up not less than 150 mm and built 30 mm into the inner leaf (see Figure 3.3.4.5).
- (c) A sill or head *flashing* may be omitted where the opening is protected by eaves or the like with a width of not less than three times the distance between the location of the *flashing* and the overhang (see Figure 3.3.4.4).

3.3.4.10 Flashings at a roof abutting a wall

3.3.4.10
Amdt No. 11

- (a) For a *cavity* wall, an end or raked apron *flashing* must be installed where the external masonry leaf or veneer abuts a roof and must-
 - (i) follow the roof line, allowing not less than 75 mm upturn to the masonry and 150 mm in width for dressing or scribing onto the roof covering; and
 - (ii) have a horizontal overflashing, stepped overflashing or raked overflashing built into the masonry leaf or veneer, except that one continuous *flashing* may be used as both an apron *flashing* or an overflashing; and
 - (iii) for parapets, be installed in accordance with Figure 3.3.4.2.
- (b) Where a roof abuts a *cavity* wall, and an external masonry leaf or veneer becomes wholly or partly an internal wall, a tray *flashing* must be installed in the cavity and-
 - (i) the tray *flashing* may be stepped to follow the rake of the roof provided that each tray *flashing* overlaps the one below by not less than 75 mm; and
 - (ii) the tray *flashing* must cover the vertical leg of the apron *flashing* required by (a) (see Figure 3.3.4.6).
- (c) For a single leaf masonry wall, an apron *flashing* onto an abutting roof must be not less than 150 mm in width for dressing or scribing onto the roof covering and must be-
 - (i) stepped to follow the rake of the roof; or
 - (ii) set not less than 30 mm into a groove cut into the masonry parallel and between 100-150 mm above the line of the roof covering.

3.3.4.11 Chimney flashings

3.3.4.11
Amdt No. 11

- (a) *Flashings* to chimneys must consist of an apron, stepped overflashings, soaker *flashings* and a back gutter (see Figure 3.3.4.3).
- (b) The apron *flashing* must be turned up the masonry not less than 75 mm and be dressed over the roof covering not less than 150 mm and installed under the soaker *flashing* not less than 75 mm.
- (c) The soaker *flashings* must be turned up the masonry not less than 75 mm and be lapped over the roof covering not less than 150 mm and installed under the back gutter not less than 75 mm.

- (d) The back gutter must be turned up the masonry not less than 75 mm, be lapped under the roof covering not less than 150 mm and extend past the full width of the soaker *flashing*.
- (e) The stepped *flashings* must be built not less than 30 mm into the masonry and must completely cover the vertical leg of the apron *flashings*, soaker *flashings* and back gutter.

3.3.4.12 Weatherproofing for single skin masonry walls

3.3.4.12
Amdt No. 11

- (a) A waterproof coating material must be applied to all external single skin masonry walls in accordance with the following:
 - (i) The coating must extend from the upper most exposed part of the wall-
 - (A) to a level adjacent the internal finished floor level, if the external blockwork overhangs the edge of the slab 10 mm; or
 - (B) 50 mm below the internal floor level if no edge overhang is provided to the blockwork (see Figure 3.3.4.9).
 - (ii) Acceptable external waterproof finishes are-
 - (A) three coats of 100% acrylic based exterior quality gloss paint; or
 - (B) one complete coat of cement based paint and two coats of 100% acrylic based exterior quality gloss paint; or
 - (C) clear water repellent, provided the wall is protected by a roof overhang.
- (b) *Windows* must be installed in accordance with Figure 3.3.4.8.
- (c) A damp-proof course and vapour barrier or damp-proofing membrane must be installed in accordance with Figure 3.3.4.9.

Limitation:

3.3.4.7 does not apply to a Class 10 building where in the particular case there is no necessity for compliance.

Amdt 11

Figure 3.3.4.8
TYPICAL WINDOW INSTALLATION DETAILS FOR SINGLE SKIN MASONRY

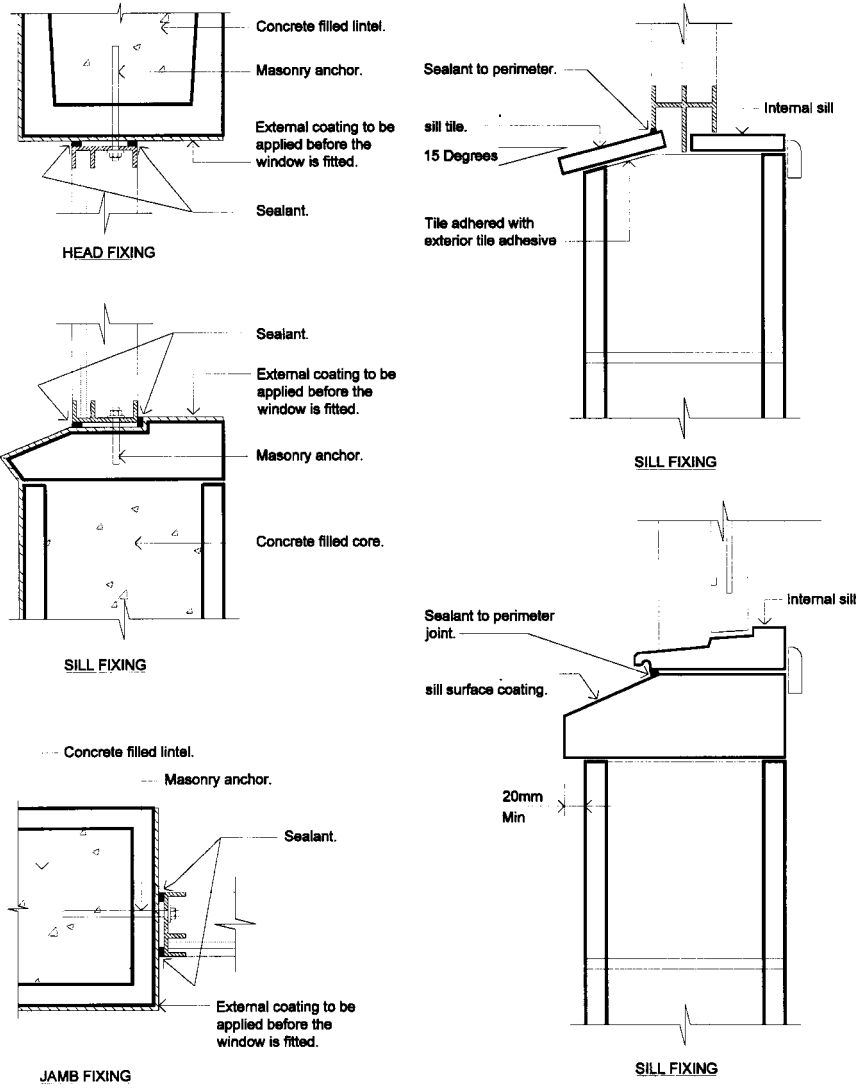

Amdt 11

Figure 3.3.4.9
TYPICAL DPC AND WEATHERPROOFING DETAILS FOR SINGLE SKIN MASONRY

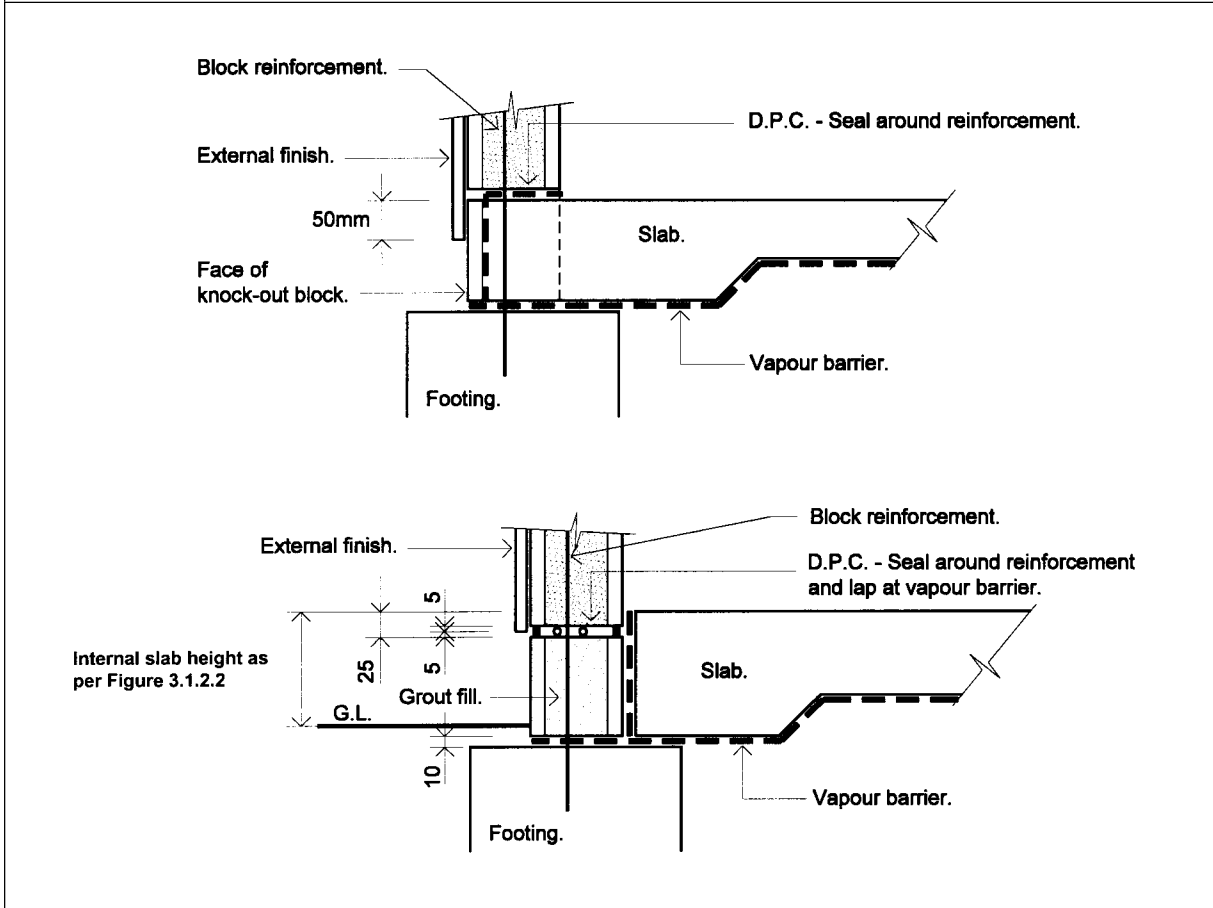

Amdt 11

PART 3.3.5 EARTH WALL CONSTRUCTION

Appropriate Performance Requirements:

Where an alternative earthwall building system is proposed to that described in Part 3.3.5, that proposal must comply with *Performance Requirement* P2.1 and P2.2.2 in Section 2.

Definitions

3.3.5 For the purpose of this Part:

Adobe construction means a type of construction using blocks of sun dried mud.

Bulletin 5 means CSIRO-NBTC Bulletin 5 Earthwall construction 4th Edition 1987.

Earthwall construction means *adobe construction, mechanically pressed-soil block construction or rammed-earth construction*.

Mechanically pressed-soil block construction means construction using blocks produced by pressed block making machines.

Rammed-earth construction means construction in which damp earth is tamped in situ between temporary movable formwork.

A. Acceptable construction manual

3.3.5.0 *Performance Requirements* P2.1 and P2.2.2 are satisfied for *earthwall construction* if it is designed and constructed in accordance with *Bulletin 5*.

Explanatory information:

Design requirements for other materials that may be used in combination with masonry ie heavy steel support beams etc. are described in Part 3.11 - Structural design.

B. Acceptable construction practice

3.3.5.1 Application

Compliance with this Part satisfies *Performance Requirements* P2.1 and P2.2.2 for *earthwall construction*, provided-

- (a) the earthwall is constructed on footings that comply with Part 3.2; and
- (b) the *design wind speed* of the area is not more than W41; and

Explanatory information:

Information on design wind speeds for particular areas may be available from the *appropriate authority*.

- (c) the *earthwall construction* does not exceed two storeys in height and walls must be laterally restrained at intermediate floor levels; and
- (d) the building is not situated on a *site* that is subject to flooding; and
- (e) for earthquake design, the building is defined as a design category H1 or H2 domestic structure in accordance with AS 1170.4.

Explanatory information:

1. This covers all *sites* except those identified by the *site* investigation as having soft soil (having a soil profile with more than 5 m of soft clay, loose sand, silt or uncontrolled fill) as defined by AS 1170.4.
2. For earthquake design H3, see AS 3700 or Part 3.10.2.

Amdt 11

3.3.5.2 General construction

A building of *earthwall construction* must be constructed in accordance with the recommendations contained in *Bulletin 5* except where varied by this Part.

3.3.5.3 Minimum thickness of walls

In a building of *earthwall construction*, the thickness of a wall must be-

- (a) in the case of *adobe construction* or *rammed-earth construction*-
 - (i) for an *external wall*, not less than 250 mm; and
 - (ii) for an internal wall, not less than 200 mm; and
- (b) in the case of *mechanically pressed-soil block construction*-
 - (i) for an *external wall*, not less than 250 mm; and
 - (ii) for an internal wall, not less than 150 mm.

3.3.5.4 Weatherproofing

Every building of *earthwall construction*-

- (a) must be provided with a suitable means of protection to prevent water from the roof running down the face of every wall; and
- (b) must, except in the case illustrated in Figure 1.3 of *Bulletin 5*, have the ground adjacent to the walls graded and paved in accordance with 1.2, 1.2.2 and 1.2.3 to prevent any *surface water* from reaching the walls.

Explanatory information:

Prior to and during construction, the following tests may be required by the *appropriate authority*-

- (a) In the case of-
 - (i) *rammed-earth construction* - a sample panel not less than 900 mm long by 900 mm high;
 - (ii) *adobe construction* - a sample comprising not less than 3 blocks, made of the materials and by the methods to be used in the construction, to be provided for inspection on the *site*.
- (b) In the case of *mechanically pressed-soil block construction* - tests, conducted in accordance with Appendix E of *Bulletin 5*, made on blocks of the kind to be used in the construction after they have been moist cured for seven days.

Amdt 11

PART **3.4**

Amdt 11

FRAMING

- 3.4 Explanation of terms**
- 3.4.1 Sub-floor Ventilation**
- 3.4.2 Steel Framing**
- 3.4.3 Timber Framing**
- 3.4.4 Structural Steel Members**

PART 3.4 FRAMING

	Page	
3.4.0	Explanation of terms	11,051
3.4.1	Sub-floor ventilation	11,101
3.4.1.1	Application	
3.4.1.2	Sub-floor ventilation	
3.4.2	Steel framing	11,301
3.4.2.0	Acceptable construction manuals	
3.4.2.1	Application	
3.4.2.2	General	
3.4.2.3	Steel floor framing	
3.4.2.4	* * *	
3.4.2.5	* * *	
3.4.2.6	Installation of services	
3.4.3	Timber framing	11,601
3.4.3.0	Acceptable construction manuals	
3.4.3.1	Application	
3.4.3.2	Materials	
3.4.3.3	Floor framing	
3.4.3.4	Flooring	
3.4.3.5	Wall framing	
3.4.3.6	Conventional roofs	
3.4.3.7	Acceptable timber frame sizes and fixing	
3.4.3.8	Bracing of timber frames	
3.4.4	Structural steel members	12,201
3.4.4	Explanation of terms	
3.4.4.0	Acceptable construction manuals	
3.4.4.1	Application	
3.4.4.2	Structural steel members	
3.4.4.3	Columns	
3.4.4.4	Corrosion protection	

Amdt 11

PART 3.4.0 EXPLANATION OF TERMS

Explanation of terms

3.4.0.1 The following diagrams depict framing members and associated terminology used to describe them in the *Housing Provisions*.

In most cases the terminology is applicable for both steel and timber frame members.

Amdt 11

**Figure 3.4.0.1
SPAN AND SPACING TERMS**

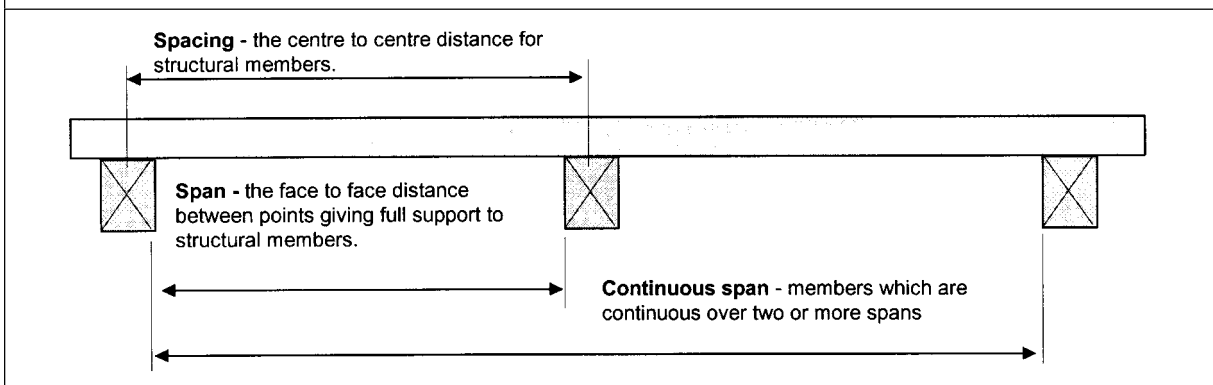

**Figure 3.4.0.2
TYPICAL ROOF FRAMING MEMBERS**

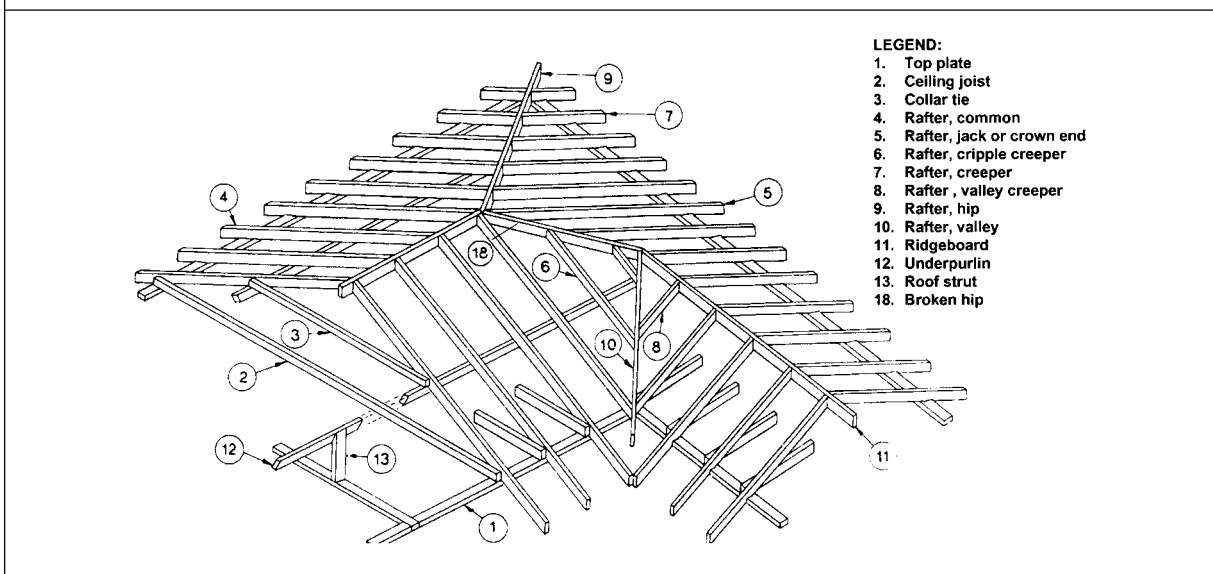
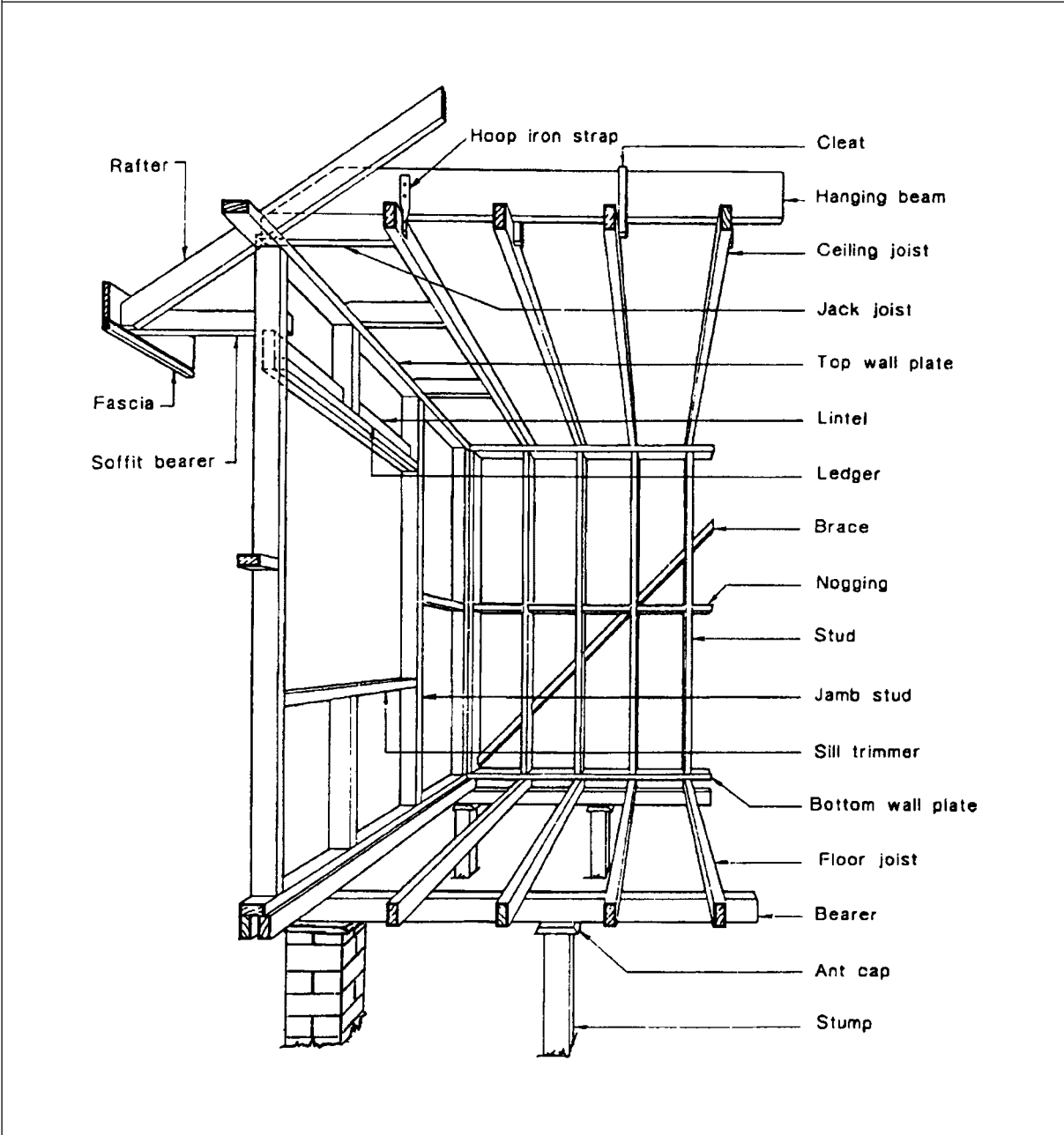

Figure 3.4.0.3
TYPICAL WALL, FLOOR AND CEILING FRAMING MEMBERS



Amdt 11

PART 3.4.1 SUB-FLOOR VENTILATION

Appropriate Performance Requirements

Where an alternative sub-floor ventilation system is proposed to that described in Part 3.4.1, that proposal must comply with *Performance Requirement P2.2.3* in Section 2.

Acceptable construction practice

3.4.1.1 Application

Compliance with this Part satisfies *Performance Requirement P2.2.3* for sub-floor ventilation.

3.4.1.2 Sub-floor ventilation

3.4.1.2
Amdt No. 5

The sub-floor space between a suspended floor of a building and the ground must be in accordance with the following:

- (a) The sub-floor space must-
 - (i) be cleared of all building debris and vegetation; and
 - (ii) be cross-ventilated by means of openings; and
 - (iii) contain no dead air spaces; and
 - (iv) be graded in accordance with 3.1.2.3; and
 - (v) have evenly spaced ventilation openings in accordance with Figure 3.4.1, Diagram a.
- (b) In double leaf masonry walls, the cross ventilation openings specified in (a) must be provided in both leaves of the masonry, with inner-leaf openings being aligned with outer leaf openings to allow an unobstructed flow of air.
- (c) Internal walls constructed in sub-floor spaces must be provided with openings-
 - (i) having an unobstructed area equivalent to that *required* for the adjacent external openings; and
 - (ii) which are evenly distributed throughout such internal walls.
- (d) The clearance between the ground surface and the underside of the floor, must be in accordance with Table 3.4.1.2.
- (e) The sub-floor ventilation openings in internal and *external walls* must be in accordance with Table 3.4.1.2 for the climatic zones given in Figure 3.4.1.2.
- (f) Where ventilation is obstructed by patios, paving or the like, additional

Amdt 11

ventilation must be provided to ensure that the overall level of ventilation is maintained.

- (g) Where the ground or sub-floor space is excessively damp or subject to frequent flooding, in addition to the requirements of (a) to (f)-
- (i) the area of sub-floor ventilation *required* in (e) must be increased by 50%; or
 - (ii) a sealed impervious membrane must be provided over the ground; or
 - (iii) Durability Class 1 or 2 timbers or H3 preservative treated timbers in accordance with AS 1684 Parts 2, 3 or 4.

Amdt No. 8

Amdt 11

Figure 3.4.1
TYPICAL SUB-FLOOR VENTILATION DETAILS

Diagram a. Typical Cross Ventilation Of Sub-Floor Area

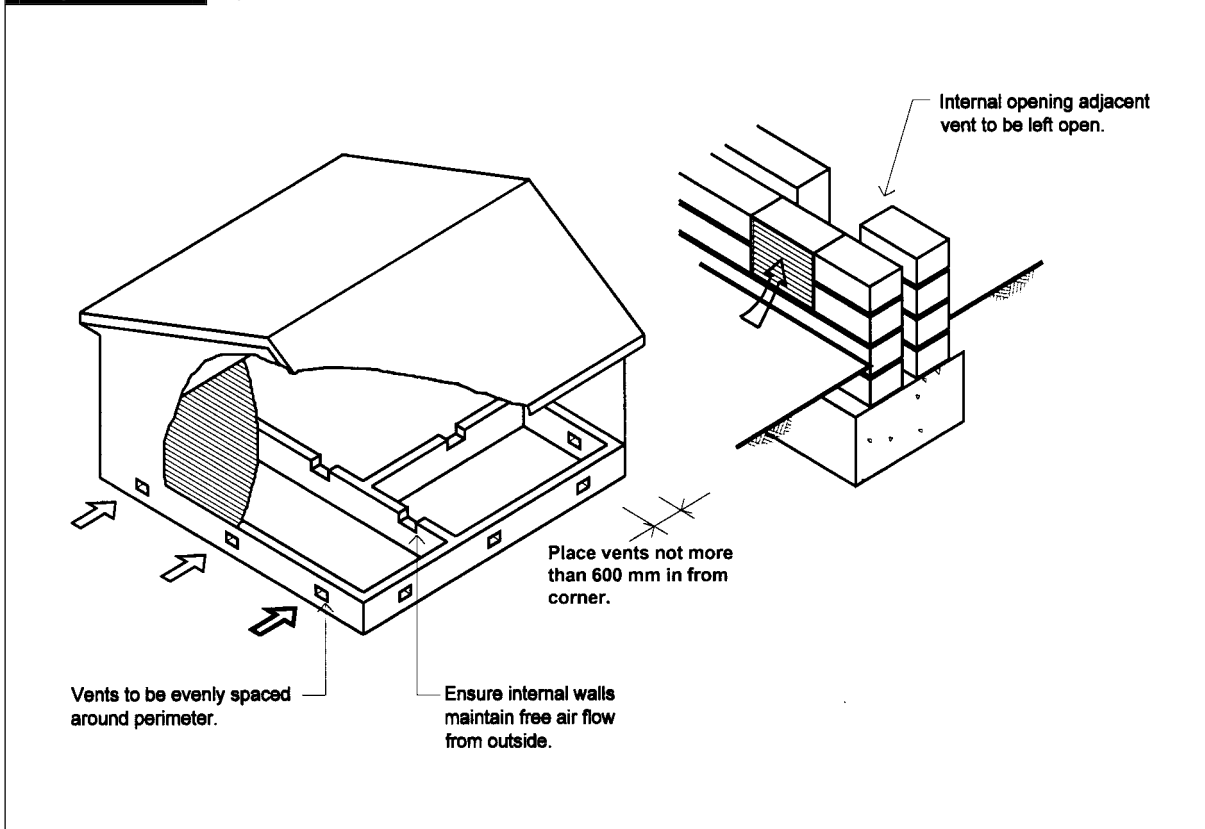
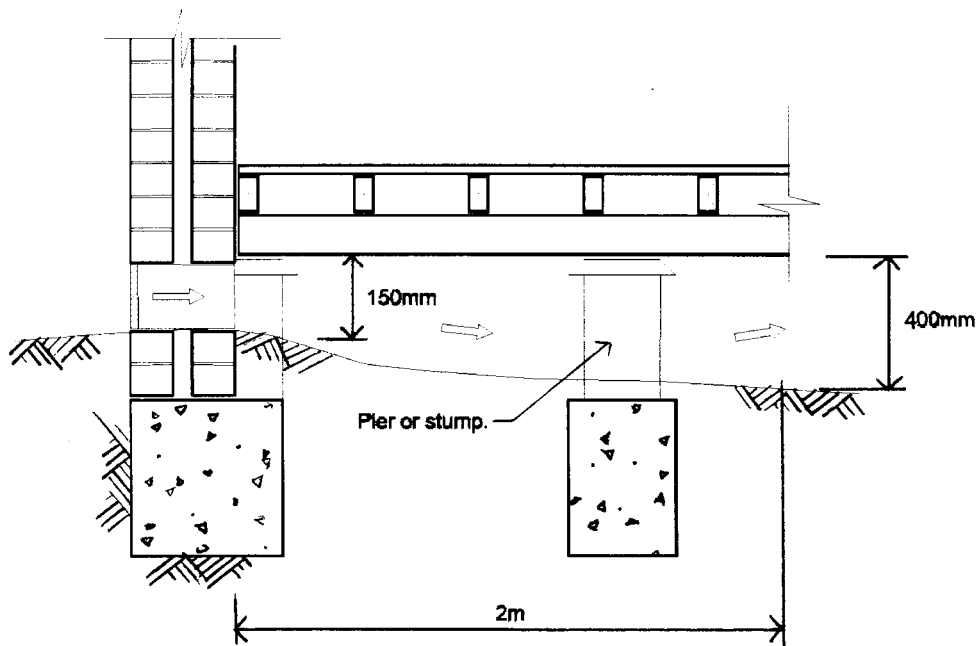

Fig 3.4.1(b)
Amdt No. 5

Figure 3.4.1
TYPICAL SUB-FLOOR VENTILATION DETAILS

- Note:**
- (a) 400 mm clearance required only where termite barriers are installed that need to be inspected (see Part 3.1.3).
 - (b) On sloping sites, 400 mm clearance may be reduced to 150 mm within 2 m of external walls in accordance with Diagram b.

Diagram b. Sub-Floor Clearance Requirements



Amdt 11

Figure 3.4.1.2
Amdt No. 5

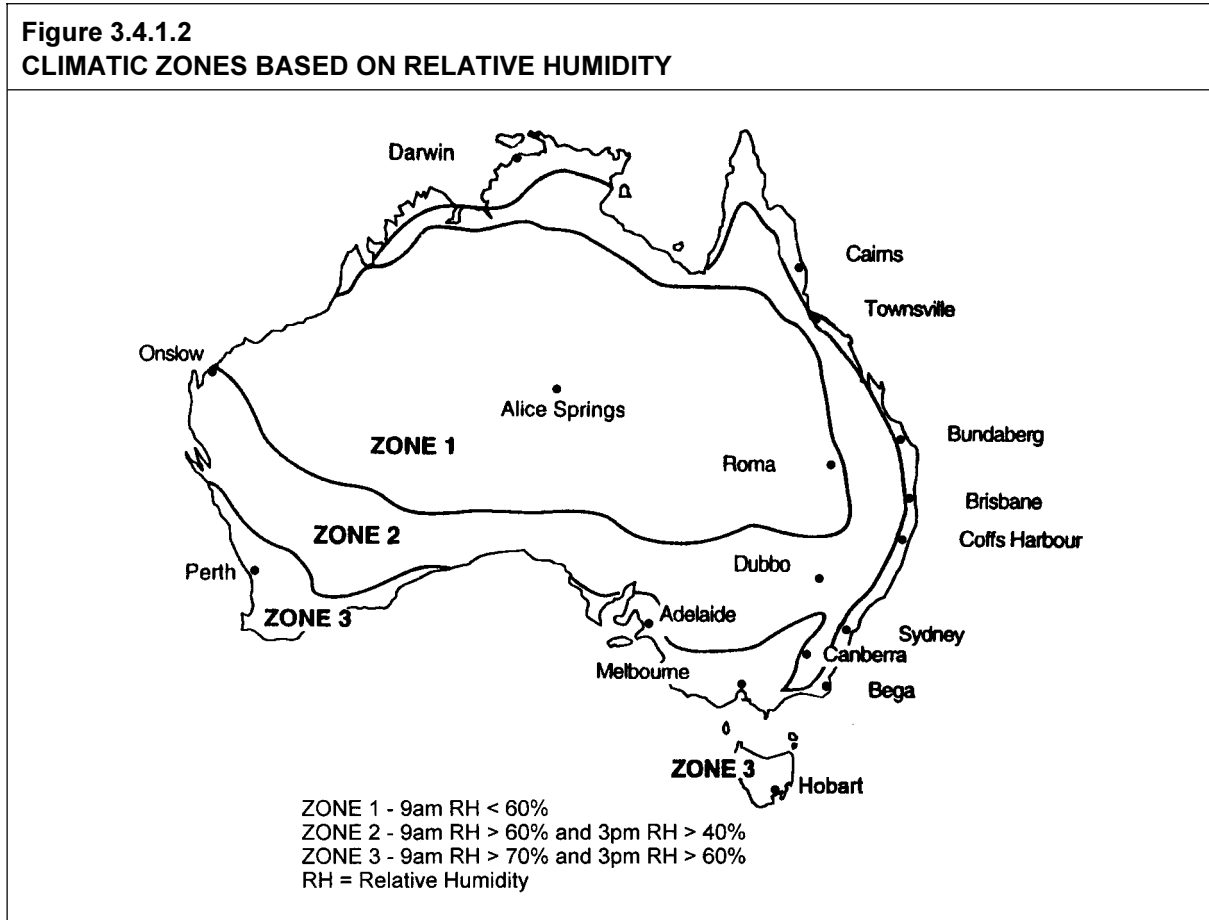

Amdt 11

Table 3.4.1.2
Amdt No. 5

**Table 3.4.1.2
SUB-FLOOR VENTILATION AND CLEARANCE**

CLIMATE ZONE (see Figure 3.4.1.2)	Minimum sub-floor ventilation (mm ² /m of wall)		Minimum height from ground surface (mm)	
	No membrane	Ground sealed with impervious membrane	Termite inspection not required	Termite inspection required (see note)
1	2000	1000	150	400
2	4000	2000	150	400
3	6000	3000	150	400

Note: On sloping sites, 400 mm clearance may be reduced to 150 mm within 2 m of external walls in accordance with Figure 3.4.1 Diagram b.

Expl. Info.
Amdt No. 5

Explanatory information:

The amount of sub-floor ventilation required for a building is related to the relative humidity likely to be encountered in that location. Figure 3.4.1.2 shows three broad climatic zones based on the prevailing relative humidity and includes a description of the relative humidity conditions which define each zone. If reliable weather data is available, these descriptions may be useful in determining which zone a particular location is in.

The zones shown in Figure 3.4.1.2 were determined by analysis of the average relative humidity at 9 am and 3 pm in January and July. The season with the highest relative humidity is used. Generally this will be July for southern Australia and January for northern Australia.

Amdt 11

PART 3.4.2 STEEL FRAMING

Appropriate Performance Requirements:

Where an alternative steel framing system is proposed to that described in Part 3.4.2, that proposal must comply with *Performance Requirement P2.1* in Section 2.

A. Acceptable construction manual

3.4.2.0 *Performance Requirement P2.1* is satisfied for cold formed steel framing if it is designed and constructed in accordance with one of the following manuals:

3.4.2.0
Amdt No. 9

- (a) AS 3623 - Domestic metal framing.
- (b) AS 4100 - Steel structures.
- (c) AS/NZS 4600 - Cold-formed steel structures.

Explanatory information:

Design requirements for other materials used in combination with steel framing, including the use of concrete floors, heavy steel support beams etc. are described in Part 3.11 - Structural design; or Part 3.4.4 for structural steel members.

B. Acceptable construction practice

3.4.2.1 Application

Compliance with this Part satisfies *Performance Requirement P2.1* for steel framing, provided-

- (a) the frame is cold-formed metal framing designed and constructed in accordance with AS 3623 or AS/NZS 4600; and
- (b) the frame material has a yield stress of not less than 250 MPa.

3.4.2.2 General

3.4.2.2
Amdt No. 3

- (a) The steel frame must be protected from corrosion in accordance with the following:
 - (i) Where the steel frame is within the building envelope, in locations-
 - (A) more than 300 m from breaking surf, or
 - (B) not in a heavy industrial area; or
 - (ii) Where the steel frame is outside the building envelope - in locations-
 - (A) more than 1 km from salt water which is not subject to breaking surf, such as a lake or protected bay; or

- (B) more than 10 km from a coastal area with breaking surf; or
- (C) not in a heavy industrial area,

the steel frame must have a minimum coating class in accordance with AS 1397 of Z275 (275 grams of zinc per square metre) or AZ150 (150 grams of aluminium/zinc per square metre).

- (iii) In areas not specified in (i) or (ii), a higher level of corrosion protection is *required*.

- (b) The frame must be permanently electrically earthed on completion of fixing.

Expl. Info.
Amdt No. 3

Explanatory information:

The steel frame requirements of this Part should be considered in conjunction with steel frame design and construction advice from the manufacturer.

For the purpose of 3.4.2.2, the building envelope is deemed to be a space in the building where the steel frame does not have direct contact with the external atmosphere, other than for normal ventilation purposes. Examples of such locations are frames which are clad or lined on both sides or frames in masonry veneer construction. Areas not within the building envelope include floor framing members where there is no continuous perimeter sub-floor walling or verandah roof framing members with no ceiling lining.

Cut edges on framing components do not constitute a corrosion problem, as the surface area of the metallic coating on either side of the cut edge is far greater than the surface area of the cut edge itself.

Where hole cutting or cutting of members is required, cutting methods that clearly shear or leave clean edges are preferred over those that leave burred edges or swarf.

The adoption of appropriate brick cleaning measures will ensure no damage of any metal or metallic coated components, this would include the shielding of these components during the acid cleaning process. Channels to steel framing should be cleaned of mortar droppings.

Metallic coated steel should not come into contact with green wood containing acidic material or CCA treated timbers unless an impervious non-conductive material is located between the dissimilar elements. The use of kiln or appropriately dried timbers is recommended where contact between the metallic coated steel component and timber is considered.

3.4.2.3 Steel floor framing

The following provisions apply to suspended steel floor framing for single-storey and both floors of two-storey construction:

- (a) The two types of suspended floor systems referred to in 3.4.2.3 are-
 - (i) in-plane systems, such as joist-only systems or systems with integral bearers; and
 - (ii) conventional joist-over-bearer systems (see Tables 3.4.2.1 and 3.4.2.2 for acceptable sizes and spacings).
- (b) When used in ground floor construction, all such systems must be installed on stumps, piers or masonry footings complying with Part 3.2. Conventional flooring can be installed on top of the floor frame.

- (c) Fibre cement packers or similarly durable and compatible materials may be used when packing is necessary under suspended flooring systems and must be at least the width of the member to ensure adequate bearing capacity.

Table 3.4.2.1 SPANS FOR C-SECTION FLOOR JOISTS			
SPAN	SECTION	Maximum Joist spacing (mm)	
		450	600
		Maximum span (mm)	
Single span	C15012	2.7	2.7
	C15015	3.3	3.0
	C15019	3.6	3.3
	C20015	4.5	3.9
	C20019	4.8	4.2
	C20024	5.1	4.5
Continuous span	C15012	4.2	3.0
	C15015	4.5	4.2
	C15019	4.8	4.5
	C20015	5.4	4.8
	C20019	5.7	5.4
	C20024	6.0	5.7

Amdt 11

Explanatory information:

The size of C-section steel members are identifiable by their description. For example, a C15012 is 150 mm deep and is made from 1.2 mm thick steel.

Table
3.4.2.2
Amdt No. 2

Table 3.4.2.2 SPANS FOR C-SECTION BEARERS										
Steel Section	SINGLE SPAN					CONTINUOUS SPAN				
	Effective Bearer Spacing (m)					Effective Bearer Spacing (m)				
	1.8	2.4	3.0	3.6	4.2	1.8	2.4	3.0	3.6	4.2
	MAXIMUM SPAN OF BEARER (m)					MAXIMUM SPAN OF BEARER (m)				
C15015	2.2	2.1	1.9	1.8	1.7	2.7	2.5	2.4	2.3	2.1
C15019	2.4	2.2	2.0	1.9	1.8	2.9	2.7	2.5	2.4	2.2
C20015	2.9	2.7	2.4	2.1	1.8	3.4	2.7	2.4	2.1	1.8
C20019	3.1	2.9	2.7	2.5	2.4	3.8	3.5	3.3	3.2	3.0
C25019	3.6	3.4	3.2	3.0	2.6	4.6	3.8	3.4	3.0	2.6
C25024	3.9	3.7	3.4	3.3	3.0	4.8	4.6	4.2	4.1	3.8
Note: For the purpose of this Table:										
(a) Loads must be evenly distributed along the member.										
(b) Sections must be stiffened at end supports.										

**Figure 3.4.2.1
TYPICAL JOIST OVER BEARER FLOORING SYSTEM**

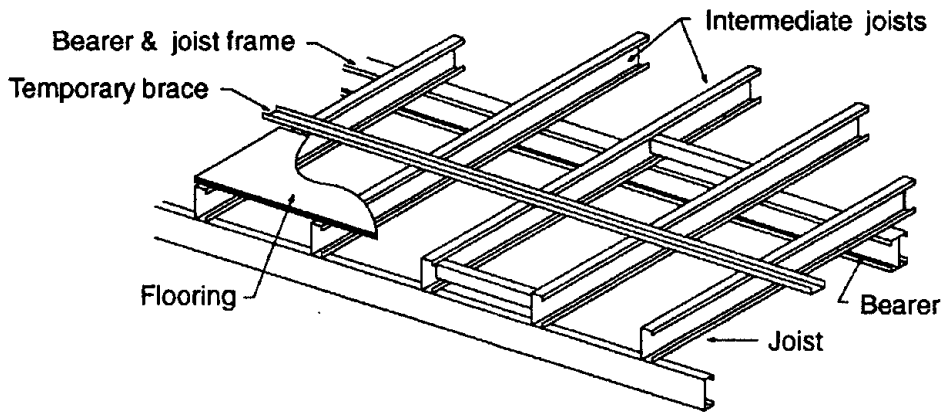

Amdt 11

3.4.2.4 * * *

**3.4.2.4
Amdt No. 5**

This clause has deliberately been left blank.

3.4.2.5 * * *

**3.4.2.5
Amdt No. 5**

This clause has deliberately been left blank.

3.4.2.6 Installation of services

To maintain the structural integrity of the frame, all ancillary work must be in accordance with the following:

- (a) Service penetrations in floor joists must comply with Figure 3.4.2.8.
- (b) Plumbing pipe-work in steel framed construction must be run in the following ways:
 - (i) Pipe-work must be-
 - (A) run through pre-punched service holes in steel studs; and
 - (B) extra holes, where necessary, must be located near the centre-line of each stud provided-
 - (aa) the structural integrity of the member is not reduced; and
 - (bb) the hole is not more than 10% larger than the existing holes.
 - (ii) In masonry veneer construction, pipe runs may be located in the *cavity* and fixed to the studs with full pipe saddles and self drilling screws

- properly protected against galvanic corrosion in accordance with (v).
- (iii) In construction where external cladding is attached directly to the steel stud work, piping can be-
 - (A) installed over the ceiling; or
 - (B) suspended under the floor; or
 - (C) installed in accordance with (i).
 - (iv) Plumbing fittings may be attached by-
 - (A) timber or steel noggings fitted between studs to support tap sets, baths and sinks; and
 - (B) where a steel nogging is used, the tap set must be isolated to prevent corrosion by a durable non corrosive material such as timber, cement sheet etc. (see Figure 3.4.2.7).
 - (v) Copper and brass pipes and fittings must be prevented from coming into contact with the steel frame by one of the following methods:
 - (A) Where plumbing services pass through service holes, plastic grommets must be snapped into the service hole.

Explanatory information:

The use of grommets also has the effect of securely fixing the pipe to prevent water hammer.

- (B) In other areas where copper pipes may come into contact with metal framing, they must be lagged or isolated with neoprene sheeting or tape.
- (c) Electrical cables must be-
 - (i) run through pre-punched service holes in steel studs (See Figure 3.4.2.7); or
 - (ii) secured to steel framing with-
 - (A) P clips; or
 - (B) plastic ratchet straps; or
 - (C) half saddles fixed with screws or rivets; and
 - (iii) extra holes, where necessary, must comply with (b)(i)(B); and
 - (iv) steel frames must be permanently earthed immediately after the frame is erected; and
 - (v) backing plates for switches and power points should be fixed at the appropriate positions with suitable fasteners. Where it is impractical to fix

directly onto studwork, steel or timber noggins can be fitted between the studs to provide necessary fixing and support.

Figure 3.4.2.7
TYPICAL INSTALLATION AND FIXING OF SERVICES

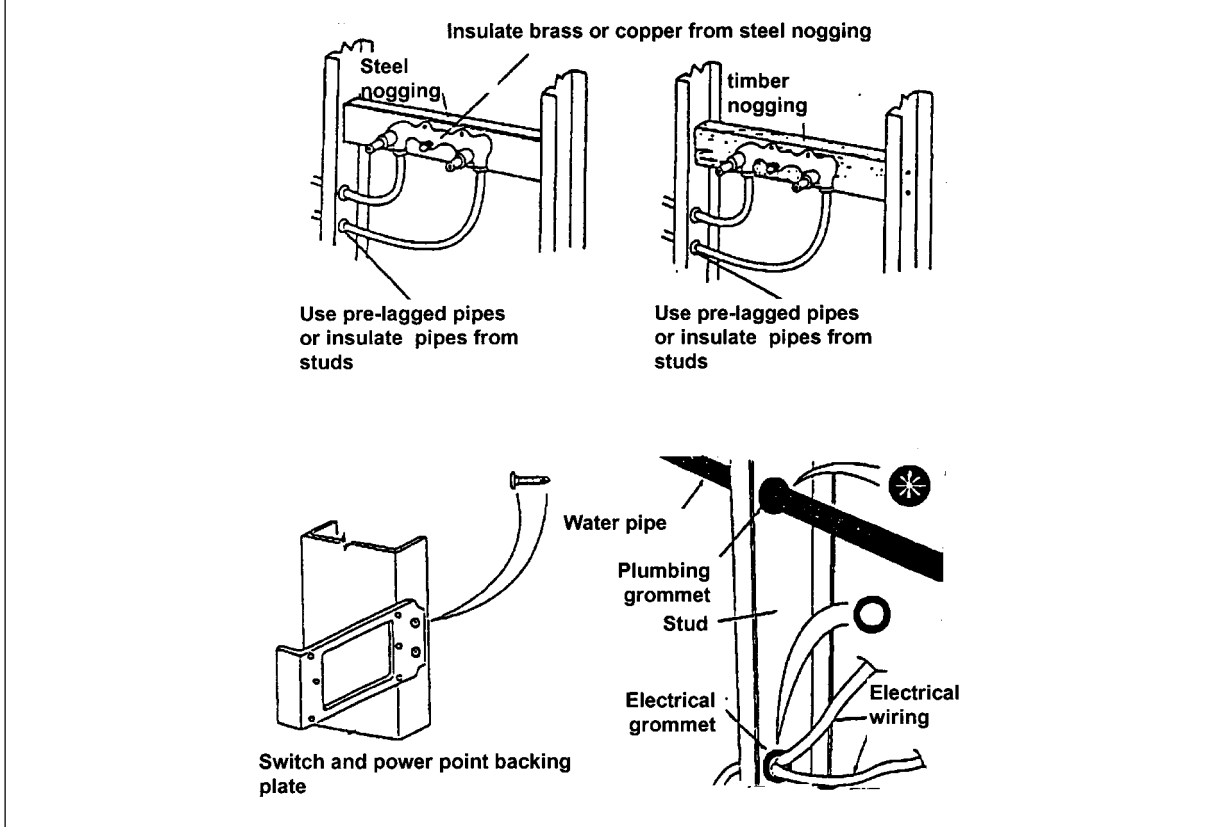

Amdt 11

Expl. Info.
Amdt No. 5

Explanatory information:

There are many different types of steel framing systems available. Each of these systems have unique design and installation requirements. Due to this diversity, there are no generic examples of acceptable construction practice for steel wall and roof framing. Accordingly, the design of these systems must be in accordance with the appropriate acceptable construction manual in 3.4.2.0.

Some of the important elements of steel frame design are contained in the following information.

Wall framing

Frames are either in rigid or adjustable form. In the case of rigid frames, minor irregularities in flooring are accommodated by packing.

With adjustable frames, the tensioner assembly on the bracing can usually be adjusted to accommodate these irregularities. After tensioning, bracing straps should be securely fixed to each stud and nogging.

Long runs of external walling may have to be temporarily braced, until the roof members have been fixed. This can be carried out by using lengths of steel, timber or roof battens fixed to the top of the studs and secured to the ground or floor, as temporary props.

Further construction stage bracing may be required to be installed before roof cladding commences. This is required to prevent side sway of the building during construction.

Construction bracing should be provided in the following minimum percentage of required vertical bracing:

- 40% single storey slab-on-ground buildings;
- 40% upper storey of buildings with suspended floors;
- 50% lower storey of 2 storey construction.

Roof framing

Trusses and rafters are fixed in accordance with the design details. Generally, the roof members are fixed to the wall structure using conventional building methods.

The fixings may incorporate nails, self-drilling screws, bolts and nuts or shear plate connectors. The fixings should be adequate to ensure that a continuous load path exists from the roof to the foundations for all types of loading including uplift, downward and shear loading.

Temporary roof bracing is generally achieved using one run of roof battens along the full length of the house. It is preferable if the run nearest the roof apex is used for this purpose and fixed as each truss is properly positioned. Next, one run of ceiling battens should be positioned and fitted. This should preferably be the batten run nearest the centre of the building.

Where ceiling battens are not used a bottom chord tie should be installed in accordance with the design details.

Wind bracing should be attached when all trusses have been erected and fixed. Generally all gable roofs and long hipped roofs require bracing in the roof plane. The strap bracing is installed similar to wall bracing and runs from the apex of the roof to the external wall, over the top of at least three trusses or rafters, at approximately 45° to the *external walls*. The bracing is fixed at the ends, tensioned and fixed to each intermediate truss or rafter.

Amdt 11

Explanatory information (continued):

Connections for steel framing

The following fasteners and connections are acceptable for the assembly and erection of steel framed houses:

Bolts: Bolted connections are used as a means of on-site jointing, particularly where joints are highly loaded and offer a consistent design strength. Bolt design for cold-formed sections is adequately covered in the Australian Standards.

Rivets: Riveted connections (either pre-drilled or self-piercing) are used for both factory and on-site fabrication and have also been used as elements of proprietary joining systems.

Screw: Self-drilling screws are widely used as a means of connection in almost every aspect of on-site work during the erection of steel framed houses. They are used for connecting wall frame modules, through to attachment of claddings and internal linings.

Adhesives: Adhesives are used in steel framing for attachment of internal linings, including flooring. They are generally used in combination with mechanical fasteners such as self-drilling screws. The screws are primarily used to fasten the linings while the adhesives set, although they continue to act as part of a composite fastening system.

Clinches: Clinching involves the connection of two thicknesses of sheet steel by extruding one sheet into the other using a punch and die, in such a way that the two pieces cannot be subsequently separated. A typical clinched joint used in factory fabrication is usually hydraulically activated whereas clinching systems used on-site are typically pneumatic or electrically driven.

Welds: Welding (typically Mig) has been the most common form of connection during factory assembly for many years. The welded joint strength can vary and the metallic coating is affected in the weld area, the affected area will require post-painting (cold galvanising).

Nails: Hard steel twist nails are used in steel framing for both factory and on-site fabrication. These nails can be used in materials up to 2 mm thick. Nails have also been used for the connection of wall plates to concrete slabs. Where this is done by hand, a timber starter block is normally used. More recently, power actuated nails have been used.

Figure 3.4.2.8
ACCEPTABLE PENETRATIONS TO STEEL FLOOR JOISTS

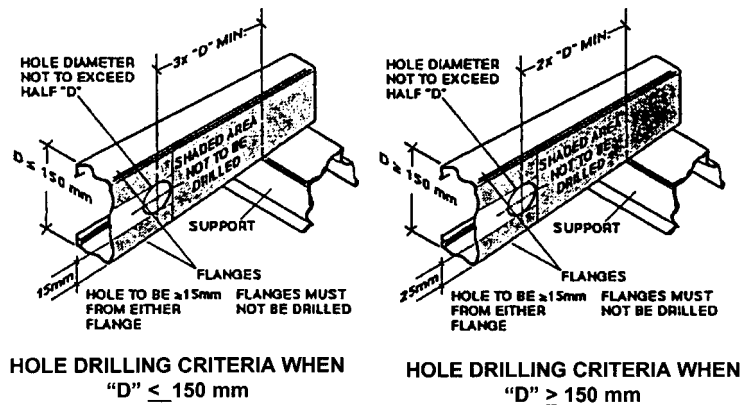

PART 3.4.3 TIMBER FRAMING

Appropriate Performance Requirements:

Where an alternative timber framing design is proposed to that described in Part 3.4.3, that proposal must comply with *Performance Requirement P2.1* in Section 2.

A. Acceptable construction manual

3.4.3.0 *Performance Requirement P2.1* is satisfied for a timber frame if it is designed and constructed in accordance with one of the following manuals:

3.4.3.0
Amdt No. 9

- (a) * * *
- (b) * * *
- (c) * * *
- (d) * * *
- (e) * * *
- (f) * * *
- (g) AS 1684.2 - Residential timber-framed construction - Non-cyclonic areas.
- (h) AS 1684.4 - Residential timber-framed construction - Simplified - Non-cyclonic areas.

STATE AND TERRITORY VARIATIONS

In Queensland after 3.4.3.0(h) insert Qld 3.4.3.0(i) as follows:

Qld 3.4.3.2(i) Timber Species

- (i) Timber Species
In addition to subclauses (a) to (h) above, timber used for structural purposes must be a species scheduled for the appropriate use in Schedules A, B or C in Queensland Forest Service of the Department of Primary Industries Technical Pamphlet No. 1 – Building Timbers, Properties and Recommendations for their Use in Queensland.

Expl. Info.
Amdt No. 8

Explanatory information:

1. Design requirements for other materials used in combination with timber framing, including the use of concrete floors, heavy steel support beams etc. are described in Part 3.11 - Structural design; or Part 3.4.4 - Structural steel members.
2. For additional construction requirements in *high wind areas* (ie >W41), see Part 3.10.1.

Amdt 11

B. Acceptable construction practice

3.4.3.1 * * *

3.4.3.1
Amdt No. 8

This clause has deliberately been left blank.

3.4.3.2 * * *

3.4.3.2
Amdt No. 8

This clause has deliberately been left blank.

3.4.3.3 * * *

3.4.3.3
Amdt No. 8

This clause has deliberately been left blank.

3.4.3.4 * * *

3.4.3.4
Amdt No. 8

This clause has deliberately been left blank.

3.4.3.5 * * *

3.4.3.5
Amdt No. 8

This clause has deliberately been left blank.

3.4.3.6 * * *

3.4.3.6
Amdt No. 8

This clause has deliberately been left blank.

3.4.3.7 * * *

3.4.3.7
Amdt No. 8

This clause has deliberately been left blank.

3.4.3.8 * * *

3.4.3.8
Amdt No. 8

This clause has deliberately been left blank.

Amdt 11

PART 3.4.4 STRUCTURAL STEEL MEMBERS

Appropriate Performance Requirements

Where an alternative structural steel member system is proposed to that described in Part 3.4.4, that proposal must comply with the structural *Performance Requirement P2.1* in Section 2.

Explanation of Terms

3.4.4 The following terms are used in this Part:

Figure 3.4.4.0
EFFECTIVE MEMBER SPACING FOR STRUCTURAL STEEL BEARERS AND STRUTTING BEAMS

Diagram a. Single spanning rafter or joist

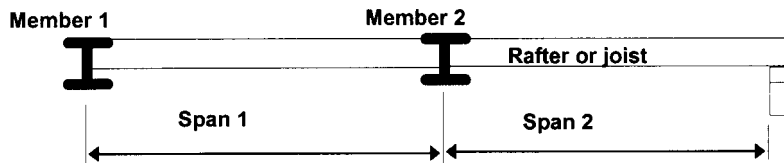

Design member	Member 1	Member 2
Effective member spacing	0.5 x Span 1	0.5 x (Span 1 + Span 2)

Diagram b. Continuous spanning rafter or joist

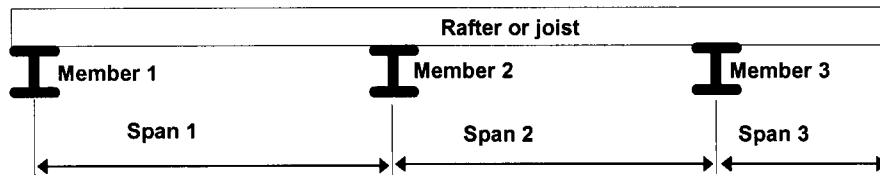

Design member	Member 1	Member 2	Member 3
Effective member spacing	0.4 x Span 1	0.6 x (Span 1 + Span 2)	0.5 x (Span 2) + Span 3

Steel member abbreviations are as follows:

TFB means a tapered flange beam.

- UB** means a universal beam.
RHS means a rectangular hollow section.
PFC means a parallel flange channel.
TFC means a tapered flange channel.
EA means an equal angle.
UA means an unequal angle.
SHS means a square hollow section.
CHS means a circular hollow section.

A. Acceptable construction manuals

3.4.4.0 Performance Requirement P2.1 is satisfied for structural steel sections if they are designed and constructed in accordance with one of the following manuals:

3.4.4.0
Amdt No. 9

- (a) AS 4100 - Steel structures.
- (b) AS/NZS 4600 - Cold-formed steel structures.

Explanatory information:

Design requirements for other materials used in combination with structural steel members are described in Part 3.4.2, 3.4.3 or Part 3.11 - Structural design.

B. Acceptable construction practice

3.4.4.1 Application

3.4.4.1
Amdt No. 9

- (a) Compliance with this Part satisfies P2.1 in respect to structural stability, provided-
 - (i) the building is located in an area with a *design wind speed* of not more than W41; and

Explanatory information:

1. Information on *design wind speeds* for particular areas may be available from the *appropriate authority*.
2. A map indicating cyclonic regions of Australia is contained in Part 3.10.1.

- (ii) the first dimension of steel sections is installed vertically; and
- (iii) all loads are uniformly distributed (unless otherwise noted or allowed for); and
- (iv) for earthquake design, the building is defined as a design category H1 or H2 domestic structure in accordance with AS 1170.4; and

Expl. Info.
Amdt No. 5

Explanatory information:

1. This covers all *sites* except those identified by the site investigation as having soft soil (having a soil profile with more than 5 m of soft clay, loose sand, silt or uncontrolled fill) as defined by AS 1170.4.
2. For earthquake design H3, see Part 3.10.2.

- (v) the structural steel member is not subject to snow loads.
- (b) Compliance with 3.4.4.4 satisfies P2.1 in respect to corrosion protection requirements.

3.4.4.2 Structural steel members

- (a) Structural steel members may be used as follows:
 - (i) Bearers supporting a timber floor or non-loadbearing stud wall - in accordance with Figure 3.4.4.1.
 - (ii) Strutting beams supporting roof and ceiling loads - in accordance with Figure 3.4.4.2.
 - (iii) Lintels supporting roof, ceiling, frame and timber floor - in accordance with Figure 3.4.4.3.
 - (iv) Columns - in accordance with 3.4.4.3.
- (b) Structural steel members described in this Part must be protected against corrosion in accordance with 3.4.4.4.
- (c) Joists, bearers and lintels must be restrained from lateral movement or twisting along their length by fixing rafters or joists to the top flange of the member so that it prevents that member from moving laterally.
- (d) End supports for joists, bearers and lintels must transfer loads to the footings and have a bearing distance as follows:
 - (i) For single spans, the bearing distance must not be less than the width of the member.
 - (ii) For continuous spans, internal bearing must be not less than 2 times the width of the member.

Amdt 11

**Figure 3.4.4.1
BEARER SUPPORTING A TIMBER FLOOR AND NON-LOADBEARING STUD WALL**

Bearer connection examples

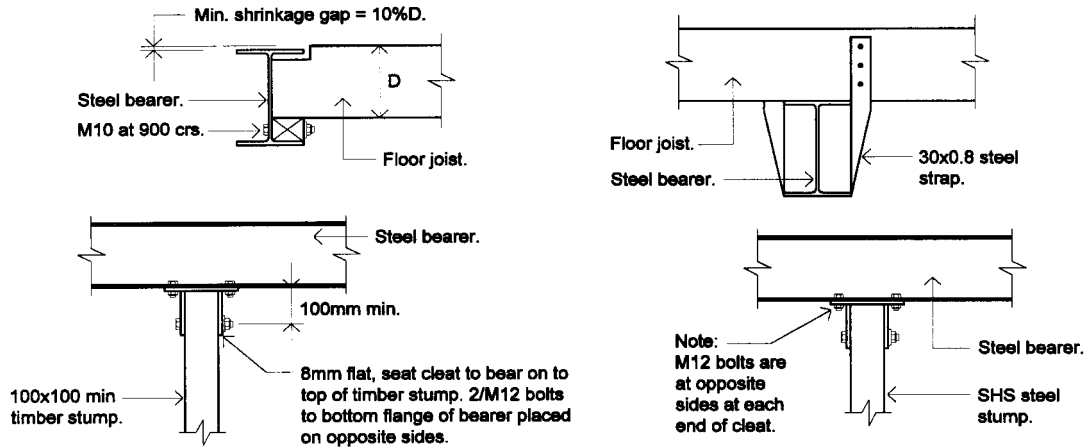

Table a. – Acceptable bearer spans

Steel Section	SINGLE SPAN					CONTINUOUS SPAN				
	<i>Effective Bearer Spacing (m)</i>					<i>Effective Bearer Spacing (m)</i>				
	1.8	2.4	3.0	3.6	4.2	1.8	2.4	3.0	3.6	4.2
	MAXIMUM SPAN OF BEARER (M)					MAXIMUM SPAN OF BEARER (M)				
125TFB	4.1	3.8	3.6	3.4	3.2	4.7	4.3	3.8	3.5	3.2
180UB16.1	5.1	4.7	4.5	4.3	4.1	5.9	5.5	5.2	5.0	4.7
200UB18.2	5.6	5.2	5.0	4.7	4.6	6.5	6.0	5.7	5.5	5.3
250UB25.7	6.8	6.4	6.0	5.8	5.6	7.9	7.4	7.0	6.7	6.4
250x150x9.0 RHS	7.7	7.1	6.7	6.4	6.2	8.8	8.2	7.8	7.4	7.1
250x150x5.0 RHS	6.8	6.3	5.9	5.7	5.5	7.8	7.2	6.8	6.5	6.3
310UB32.0	7.9	7.3	7.0	6.7	6.4	9.1	8.5	8.1	7.7	7.4
125x75x2.0 RHS	3.1	2.8	2.6	2.5	2.4	4.0	3.7	3.5	3.3	3.1
125x75x3.0 RHS	3.5	3.2	3.0	2.8	2.7	4.4	4.1	3.9	3.7	3.5
150x50x2.0 RHS	3.4	3.1	2.8	2.7	2.5	4.2	3.9	3.7	3.5	3.4
150x50x3.0 RHS	3.7	3.4	3.2	3.0	2.9	4.6	4.3	4.1	3.9	3.7
100TFC	3.2	2.9	2.7	2.6	2.4	3.7	3.2	2.8	2.6	2.4
150PFC	4.8	4.5	4.2	4.0	3.9	5.5	5.1	4.9	4.7	4.5
180PFC	5.4	5.1	4.8	4.6	4.4	6.3	5.9	5.6	5.3	5.1
200PFC	5.9	5.5	5.2	5.0	4.8	6.8	6.3	6.0	5.7	5.50
250PFC	7.2	6.7	6.4	6.1	5.9	8.4	7.8	7.4	7.1	6.8
300PFC	8.1	7.6	7.2	6.9	6.6	9.4	8.8	8.3	8.0	7.7

Notes:

1. Steel is base grade.
2. Load must be evenly distributed along the member.
3. For continuous floor bearers, the variation in span length should not be more than 10%.
4. See 3.4.2.3 for provisions that apply to suspended floors in single storey and ground floor construction of suspended steel floor frames.
5. Effective bearer spacing is a measure of the width of the load area being supported by the member (see Figure 3.4.4.0).

Amdt 11

**Figure 3.4.4.2
STRUTTING BEAM SUPPORTING A ROOF AND CEILING**

Strutting beam application

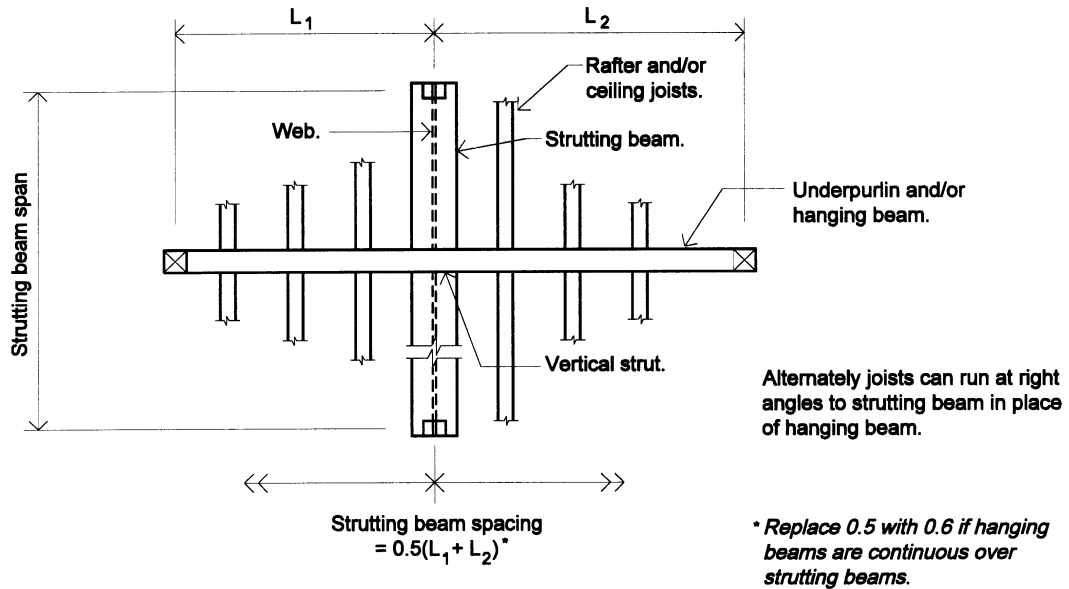

Table a. – Acceptable strutting beam spans

Steel Section	STEEL SHEET ROOF					TILED ROOF				
	Strutting Beam Spacing (m)					Strutting Beam Spacing (m)				
	1.8	2.4	3.0	3.6	4.2	1.8	2.4	3.0	3.6	4.2
	MAXIMUM SPAN OF STRUTTING BEAM (M)					MAXIMUM SPAN OF STRUTTING BEAM (M)				
125TFB	5.7	5.4	5.1	4.9	4.6	4.9	4.6	4.4	4.2	4.1
150UB14.0	6.4	6.0	5.7	5.4	5.1	5.5	5.2	4.9	4.7	4.5
200UB18.2	7.9	7.4	7.1	6.8	6.5	6.9	6.4	6.1	5.8	5.6
250UB31.4	10.0	9.4	9.0	8.7	8.4	8.8	8.2	7.8	7.5	7.2
310UB46.2	11.9	11.3	10.8	10.5	10.1	10.6	10.0	9.5	9.1	8.8
100TFC	4.6	4.4	4.2	3.9	3.7	4.0	3.7	3.6	3.4	3.2
150PFC	6.7	6.3	6.0	5.8	5.6	5.8	5.5	5.2	5.0	4.8
200PFC	8.2	7.7	7.4	7.1	6.8	7.2	6.7	6.4	6.1	5.9
250PFC	10.0	9.4	9.0	8.7	8.4	8.8	8.2	7.8	7.5	7.3
300PFC	11.1	10.5	10.1	9.7	9.4	9.8	9.3	8.8	8.4	8.2

Note:

1. If point load applied, then it should be located within the middle third of the strutting beam span.
2. Top and bottom flanges of strutting beam must be laterally restrained at the loading point.
3. Strutting beam must be tied down at the support points, in the case of steel sheet roofs.
4. Steel is base grade.

Amdt 11

Figure 3.4.4.3
LINTELS SUPPORTING ROOF, FRAMES AND TIMBER FLOORS

Lintels supporting roof and floors

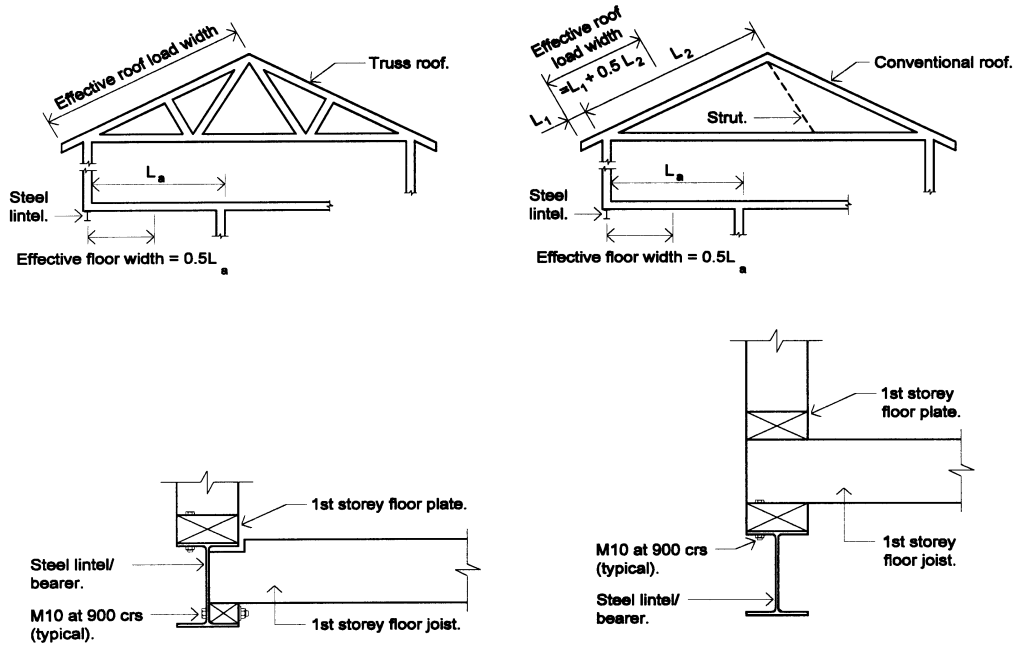

Table a. – Acceptable spans for lintels

Steel Section	STEEL SHEET ROOF					TILED ROOF				
	Effective Load Width (m)					Effective Load Width (m)				
	1.8	2.4	3.0	3.6	4.2	1.8	2.4	3.0	3.6	4.2
	MAXIMUM SPAN OF LINTEL (M)					MAXIMUM SPAN OF LINTEL (M)				
125TFB	3.7	3.4	3.2	3.0	2.8	3.6	3.3	3.0	2.9	2.7
150UB14.0	4.1	3.9	3.7	3.5	3.3	4.0	3.7	3.5	3.3	3.2
200UB25.4	5.6	5.3	5.0	4.8	4.7	5.4	5.1	4.8	4.6	4.5
250UB31.4	6.6	6.2	5.9	5.7	5.5	6.3	6.0	5.7	5.4	5.2
100TFC	2.8	2.6	2.4	2.3	2.1	2.7	2.5	2.3	2.1	2.0
150PFC	4.4	4.1	3.9	3.7	3.6	4.2	3.9	3.7	3.6	3.4
200PFC	5.4	5.0	4.8	4.6	4.4	5.1	4.8	4.6	4.4	4.2
250PFC	6.6	6.2	5.9	5.7	5.5	6.3	6.0	5.7	5.4	5.3
75x75x5EA	1.3	1.2	1.1	-	-	1.3	1.1	-	-	-
90x90x6EA	1.9	1.6	1.5	1.3	1.2	1.7	1.5	1.4	1.3	1.2
100x100x6EA	2.0	1.8	1.6	1.5	1.4	1.9	1.7	1.5	1.4	1.3
125x75x6UA	2.3	2.0	1.8	1.7	1.5	2.2	1.9	1.7	1.6	1.4
150x100x10UA	3.9	3.6	3.2	2.9	2.7	3.7	3.3	3.0	2.8	2.6

Note:

1. Top flange of lintel must be laterally restrained at the loading points.
2. Load must be evenly distributed along the member, eg joists.
3. Angle lintels – first dimension corresponds to vertical leg, eg 100x75x6UA, 100 mm leg is vertical.
4. For lintels supporting masonry walls, see Part 3.3.3.

Amdt 11

3.4.4.3 Columns

Columns may support the area provided for in Table 3.4.4.1 provided-

- (a) the effective height of the column is determined in accordance with Figure 3.4.4.4; and
- (b) the *floor area* to be supported is determined in accordance with Figure 3.4.4.5; and
- (c) the load eccentricity between the centre of the column and the applied vertical loading complies with Figure 3.4.4.6.

Figure 3.4.4.4
DETERMINING EFFECTIVE COLUMN HEIGHT

Note: For the purposes of this Figure, to determine the column effective height, the actual column height (H) in Diagram a. must be multiplied by a column height factor (F1) in Table a.

Diagram a. Column height (H)

Note: H = Distance measured from the top of footing to underside of supported beam or bearer, or between intermediate lateral bracing points.

Table a. Column height factor (F1)		
BASE DETAIL	BRACING SYSTEM	
	Fully Braced ⁽¹⁾ Construction	Unbraced Construction (cantilever columns) ⁽²⁾
Cast into footing	1.00	2.60
Fixed by bolts to footing or slab	1.20	must not be used
Fixed by intermediate floor or bracing in both directions	1.20	2.60
Note:		
The flooring system must be fully braced to footing level by-		
(a)	a combination of column bracing sets, and timber or masonry bracing walls; or	
(b)	the provision of cantilever steel columns only (ie no column bracing sets, timber or masonry bracing walls).	

Amdt 11

Figure 3.4.4.5
DETERMINING FLOOR AREA SUPPORTED

Note: The total area supported depends on the position of the column in the structure as shown in Diagram a. To calculate the correct area supported by a column, match the column's position with those shown in Diagram a. which shows a plan view of a floor and then calculate the total area supported from Table a.

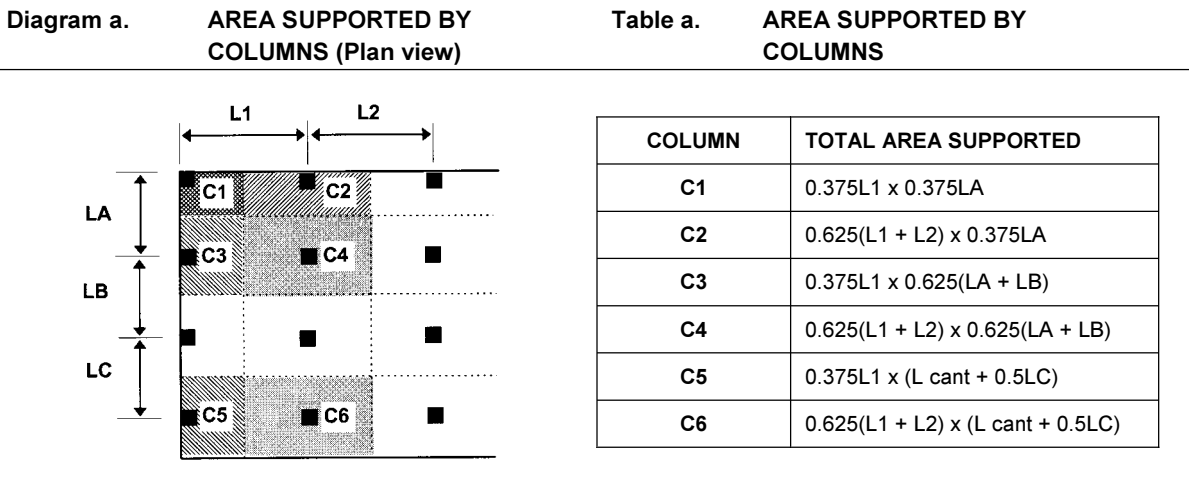

Amdt 11

Figure 3.4.4.6
ACCEPTABLE LOAD ECCENTRICITY FOR COLUMNS

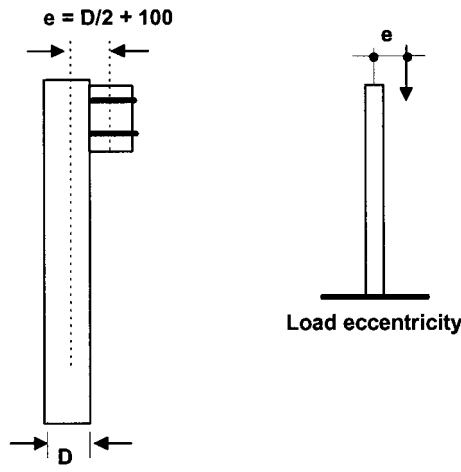

**Table
3.4.4.1
Amdt No. 2**

Table 3.4.4.1 COLUMNS - SUPPORTING TIMBER FLOOR ONLY						
Note: Tabulated values are the columns sections to be used.						
COLUMN EFFECTIVE HEIGHT (mm)	FLOOR AREA SUPPORTED(m²)					
	5	10	15	20	25	
CHS C250	600	60.3 x 3.6	88.9 x 4.0	101.6 x 5.0	114.3 x 5.4	139.7 x 5.0
	1200	60.3 x 4.5	88.9 x 4.0	101.6 x 5.0	114.3 x 5.4	139.7 x 5.0
	1800	60.3 x 4.5	88.9 x 4.0	101.6 x 5.0	114.3 x 5.4	139.7 x 5.0
	2400	60.3 x 4.5	88.9 x 4.0	101.6 x 5.0	114.3 x 5.4	139.7 x 5.0
	3600	76.1 x 3.6	101.6 x 4.0	114.3 x 4.5	139.7 x 5.0	139.7 x 5.0
CHS C350	600	60.3 x 2.9	88.9 x 2.6	101.6 x 3.2	114.3 x 3.6	139.7 x 3.5
	1200	60.3 x 2.9	88.9 x 2.6	101.6 x 3.2	114.3 x 3.6	139.7 x 3.5
	1800	60.3 x 2.9	101.6 x 2.6	114.3 x 3.2	114.3 x 3.6	139.7 x 3.5
	2400	76.1 x 2.3	101.6 x 2.6	114.3 x 3.2	139.7 x 3.0	139.7 x 3.5
	3600	88.9 x 2.6	101.6 x 2.6	114.3 x 3.2	139.7 x 3.0	165.1 x 3.0
SHS C350	600	50 x 50 x 2.5	75 x 75 x 2.5	75 x 75 x 4.0	100 x 100 x 4.0	100 x 100 x 4.0
	1200	65 x 65 x 2.0	75 x 75 x 2.5	75 x 75 x 4.0	100 x 100 x 4.0	100 x 100 x 4.0
	1800	65 x 65 x 2.0	75 x 75 x 3.0	100 x 100 x 3.0	100 x 100 x 4.0	100 x 100 x 4.0
	2400	65 x 65 x 2.0	75 x 75 x 3.0	100 x 100 x 3.0	100 x 100 x 4.0	100 x 100 x 5.0
	3600	65 x 65 x 2.5	75 x 75 x 4.0	100 x 100 x 3.0	100 x 100 x 4.0	100 x 100 x 5.0
SHS C450	600	50 x 50 x 2.0	65 x 65 x 2.5	75 x 75 x 3.0	100 x 100 x 2.8	100 x 100 x 3.3
	1200	50 x 50 x 2.0	65 x 65 x 2.5	75 x 75 x 3.0	100 x 100 x 3.0	100 x 100 x 3.3
	1800	50 x 50 x 2.3	75 x 75 x 2.3	75 x 75 x 3.3	100 x 100 x 3.0	100 x 100 x 3.8
	2400	65 x 65 x 2.0	75 x 75 x 2.5	75 x 75 x 3.5	100 x 100 x 3.0	100 x 100 x 3.8
	3600	65 x 65 x 2.3	100 x 100 x 2.0	100 x 100 x 2.8	100 x 100 x 3.8	100 x 100 x 4.0
COLUMNS - SUPPORTING TILE ROOF ONLY						
COLUMN EFFECTIVE HEIGHT (mm)	ROOF AREA SUPPORTED (m²)					
	5	10	15	20	25	
CHS C250	600	60.3 x 3.6	60.3 x 3.6	76.1 x 3.6	76.1 x 4.5	88.9 x 4.0
	1200	60.3 x 3.6	60.3 x 3.6	76.1 x 3.6	76.1 x 4.5	101.6 x 4.0
	1800	60.3 x 3.6	60.3 x 3.6	76.1 x 3.6	76.1 x 4.5	101.6 x 4.0
	2400	60.3 x 3.6	60.3 x 4.5	76.1 x 3.6	88.9 x 4.0	101.6 x 4.0
	3600	60.3 x 3.6	76.1 x 3.6	76.1 x 4.5	88.9 x 4.0	101.6 x 4.0
CHS C350	600	60.3 x 2.3	60.3 x 2.3	76.1 x 2.3	88.9 x 2.6	101.6 x 2.6
	1200	60.3 x 2.3	60.3 x 2.9	76.1 x 2.3	88.9 x 2.6	101.6 x 2.6
	1800	60.3 x 2.3	60.3 x 2.9	88.9 x 2.6	88.9 x 2.6	101.6 x 2.6
	2400	60.3 x 2.3	76.1 x 2.3	88.9 x 2.6	88.9 x 2.6	101.6 x 2.6
	3600	60.3 x 2.3	76.1 x 2.3	88.9 x 2.6	101 x 2.6	101.6 x 3.2
SHS C350	600	50 x 50 x 2.0	50 x 50 x 2.5	65 x 65 x 2.5	75 x 75 x 2.5	75 x 75 x 3.0
	1200	50 x 50 x 2.0	50 x 50 x 2.5	65 x 65 x 2.5	75 x 75 x 2.5	75 x 75 x 3.0
	1800	50 x 50 x 2.0	65 x 65 x 2.0	65 x 65 x 2.5	75 x 75 x 2.5	75 x 75 x 3.0
	2400	50 x 50 x 2.0	65 x 65 x 2.0	65 x 65 x 2.5	75 x 75 x 2.5	75 x 75 x 4.0
	3600	50 x 50 x 2.5	65 x 65 x 2.5	75 x 75 x 2.5	75 x 75 x 3.0	75 x 75 x 4.0
SHS C450	600	50 x 50 x 1.6	50 x 50 x 2.0	65 x 65 x 2.0	65 x 65 x 2.3	65 x 65 x 2.8
	1200	50 x 50 x 1.6	50 x 50 x 2.0	65 x 65 x 2.0	65 x 65 x 2.3	65 x 65 x 2.8
	1800	50 x 50 x 1.6	65 x 65 x 1.6	65 x 65 x 2.0	65 x 65 x 2.5	75 x 75 x 2.5
	2400	50 x 50 x 1.6	50 x 50 x 2.5	65 x 65 x 2.3	75 x 75 x 2.3	75 x 75 x 2.8
	3600	50 x 50 x 2.0	65 x 65 x 2.0	75 x 75 x 2.3	100 x 100 x 2.0	100 x 100 x 2.3

Amdt 11

3.4.4.4 Corrosion protection

Structural steel members must be protected against corrosion in accordance with Table 3.4.4.2.

Expl. Info.
Amdt No. 10

Explanatory information:

1. For internal steelwork, where the steel is situated in a basically permanently dry location, the steel normally needs little or no protection.
2. Beams over kitchens and bathrooms and the like, where moisture may be present, may need increased protection.
3. For applications outside the scope of this table, seek specialist advice.

Amdt 11

Table
3.4.4.2
Amdt No. 10

Table 3.4.4.2 PROTECTIVE COATINGS FOR STEELWORK			
ENVIRONMENT	LOCATION	MINIMUM PROTECTIVE COATING	
		General structural steel members	Lintels in masonry
MODERATE More than 1 km from breaking surf or more than 100 m from salt water not subject to breaking surf or non-heavy industrial areas	INTERNAL	No protection required	
	EXTERNAL	Option 1. 2 coats alkyd primer; or Option 2. 2 coats alkyd gloss Option 3. Hot dip galvanise 300 g/ m ² min Option 4. Hot dip galvanise 100 g/m ² min plus - (a) 1 coat solvent based vinyl primer; or (b) 1 coat vinyl gloss or alkyd.	
SEVERE Within 1 km from breaking surf or within 100 m of salt water not subject to breaking surf or heavy industrial areas	INTERNAL	Option 1. 2 coats alkyd primer Option 2. 2 coats alkyd gloss	
	EXTERNAL	Option 1. Inorganic zinc primer plus 2 coats vinyl gloss finishing coats Option 2. Hot dip galvanise 300g/m ² Option 3. Hot dip galvanise 100 g/m ² min plus - (a) 2 coats solvent based vinyl primer; or (b) 2 coats vinyl gloss or alkyd.	Hot dip galvanise 600g/m ²
Notes: 1. Heavy industrial areas means industrial environments around major industrial complexes. There are only a few such regions in Australia, examples of which occur around Port Pirie and Newcastle. 2. The outer leaf and cavity of an external masonry wall of a building, including walls under open carports are considered to be external environments. A part of an internal leaf of an external masonry wall which is located in the roof space is considered to be in an internal environment. 3. Where a paint finish is applied the surface of the steel work must be hand or power tool cleaned to remove any rust immediately prior to painting. 4. All zinc coatings (including inorganic zinc) require a barrier coat to stop conventional domestic enamels from peeling. 5. Refer to the paint manufacturer where decorative finishes are required on top of the minimum coating specified in the table for protection of the steel against corrosion.			

Amdt 11

PART **3.5**

Amdt 11

ROOF AND WALL CLADDING

- 3.5.1 Roof Cladding
- 3.5.2 Gutters and Downpipes
- 3.5.3 Wall Cladding

PART 3.5 ROOF AND WALL CLADDING

	Page
3.5.1 Roof cladding	13,021
3.5.1.0 Acceptable construction manuals	
3.5.1.1 Application	
3.5.1.2 Roof tiling	
3.5.1.3 Metal sheet roofing	
3.5.2 Gutters and downpipes	13,301
3.5.2.0 Acceptable construction manual	
3.5.2.1 Application	
3.5.2.2 Materials	
3.5.2.3 Selection of guttering	
3.5.2.4 Installation of gutters	
3.5.2.5 Downpipes - size and installation	
3.5.3 Wall cladding	13,501
3.5.3.1 Application	
3.5.3.2 Timber weatherboard cladding	
3.5.3.3 Fibre cement planks and weatherboard cladding	
3.5.3.4 Sheet wall cladding	
3.5.3.5 Eaves and soffit linings	
3.5.3.6 Flashings to wall openings	

Explanatory information:

These provisions relate to installing systems to waterproof roofs, walls and wall openings.

It should be noted that other construction methods may be used to achieve the same results as specified in this Part provided they comply with the appropriate *Performance Requirement*.

PART 3.5.1 ROOF CLADDING

Appropriate Performance Requirements:

Where an alternative roof cladding is proposed to that described in Part 3.5.1, that proposal must comply with the structural *Performance Requirements* P2.1 and P2.2.2 in Section 2.

A. Acceptable construction manuals

3.5.1.0 *Performance Requirements* P2.1 and P2.2.2 are satisfied for roof cladding on Class 1 and 10 buildings if it complies with one of the following manuals:

3.5.1.0
Amdt No. 9

- (a) AS 2049 - Roof tiles.
- (b) AS 2050 - Installation of roof tiles.
- (c) AS 1562.1 - Design and installation of sheet roof and wall cladding – Metal.
- (d) AS/NZS 4256 Pts 1, 2, 3 and 5; and AS/NZS 1562.3 - Plastic sheet roofing.
- (e) AS/NZS 1562.2 - Design and installation of sheet roof and wall cladding - Corrugated fibre reinforced cement.
- (f) ASTM D3018-90 - Asphalt shingles.
- (g) AS/NZ 4200 - Installation of pliable membrane and underlay.

B. Acceptable construction practice

3.5.1.1 Application

Compliance with this Part satisfies *Performance Requirements* P2.1 and P2.2.2 for roof cladding, provided-

- (a) the building is located in an area with a *design wind speed* of not more than W41; and

Explanatory information:

1. Information on *design wind speeds* for particular areas may be available from the *appropriate authority*.
2. A map indicating cyclonic regions of Australia is contained in Part 3.10.1.

- (b) roof tiles are installed in accordance with 3.5.1.2; and
- (c) sheet roofing is installed in accordance with 3.5.1.3.

3.5.1.2 Roof tiling

- (a) Roof tiles, complying with AS 2049, must be installed, fixed and flashed in accordance with the relevant provisions of this Part.
- (b) Roof tiles on roofs with a pitch not more than 35 degrees must be fixed in accordance with Figure 3.5.1.1.
- (c) Fixings for roof battens and batten sizes must comply with Part 3.4.3.
- (d) All tiled roof *flashings*, ridge and hip tiles must be installed in accordance with Figure 3.5.1.2.

Amdt 11

**Figure 3.5.1.1
RIDGE AND HIP TILES MECHANICAL FIXING REQUIREMENTS – PITCH NOT MORE THAN 35 DEGREES**

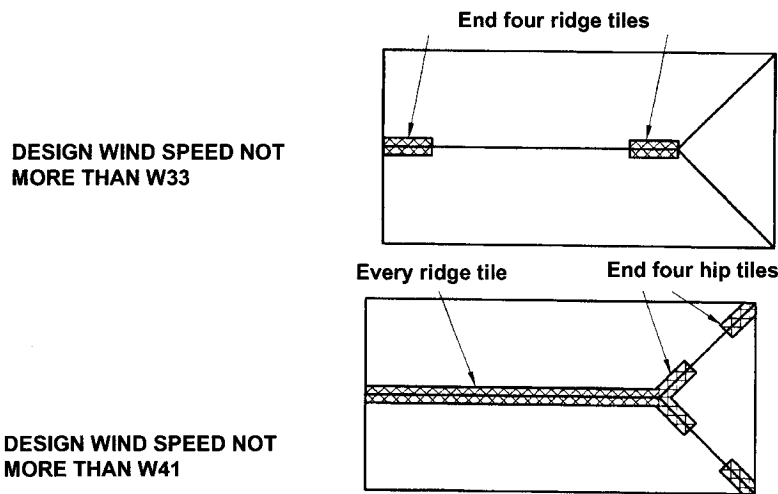

Design wind speed	Tile fixing		Ridge fixing (see Figure 3.5.1.2)		Barge fixing
	Edge of roof	Field of roof	Ridge tiles	Hip ridge tiles	
<W33	Mechanically fix each full tile in 2nd course and then either every 2nd tile in every course, or every tile in every 2nd course.		Mechanically fix the end four ridge tiles	Mortar in accordance with 3.3.1.6	Mechanically fix each barge tile
W33 – W41	Mechanically fix each full tile in 2nd course	Meachanically fix each 2nd full tile	Mechanically fix every ridge tile	Mechanically fix the end four hip ridge tiles	Mechanically fix each barge tile

**Figure 3.5.1.2
TILED ROOF FLASHING AND OTHER DETAILS**

a. Mechanical fixing-ridge clip (Also see Figure 3.5.1.1)

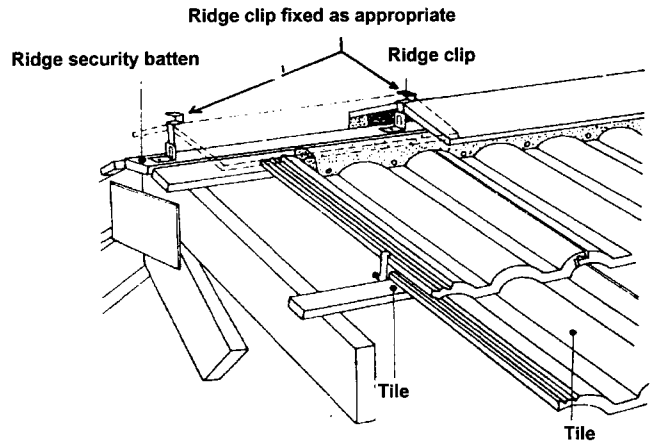

b. Dry valley

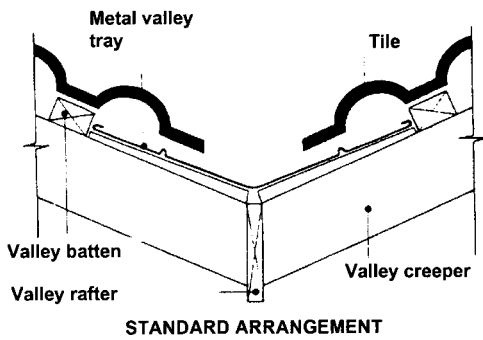

c. Bedded and pointed valley

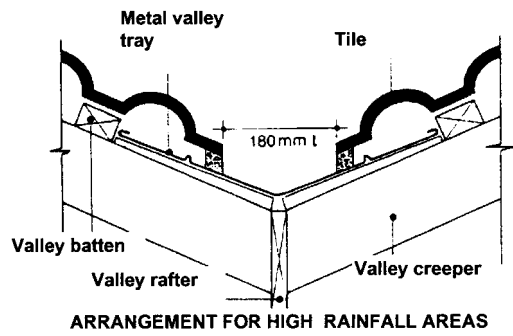

d. Fixing of hip tiles

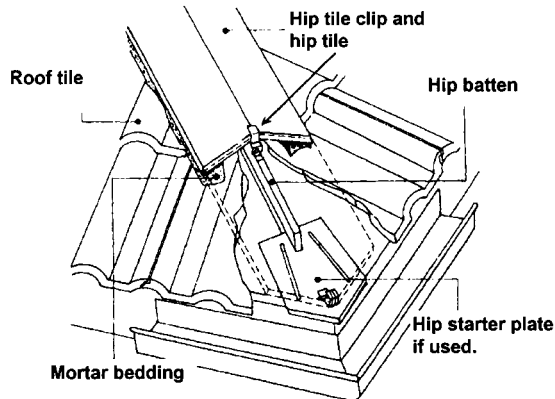

Amdt 11

3.5.1.3 Metal sheet roofing

**3.5.1.3
Amdt No. 11**

- (a) The design and installation of metal sheet roofing must comply with the relevant provisions of this Part.
- (b) Metal sheet roofing must be protected from corrosion in accordance with Table 3.5.1.1.

Table 3.5.1.1 ACCEPTABLE CORROSION PROTECTION FOR SHEET ROOFING		
ROOF ENVIRONMENT	METAL COATING IN ACCORDANCE WITH AS 1397	
	Metallic coated steel	Metallic and organic coating
Moderate Inland areas with no salt or heavy industry pollution	(a) Z450 galvanised (b) AZ150 zinc/aluminium	(a) Z275 galvanised (b) AZ150 zinc/aluminium
Severe Close to the sea with frequent onshore winds and in local areas with heavy industrial pollution	AZ200	Not suitable

- (c) Where different metals are used in a roofing system, including cladding, *flashings*, fasteners, downpipes etc, they must be compatible with each other (to prevent corrosion due to an adverse chemical reaction) as described in Table 3.5.1.2 and-
 - (i) no lead materials can be used upstream from zinc-aluminium coated materials; and
 - (ii) no copper materials can be used upstream from galvanised coated materials.
- (d) Metal sheet roofing must-
 - (i) be fixed at spacings in accordance with Figure 3.5.1.5; and
 - (ii) use fastening devices made of a compatible metal to the roofing in accordance with 3.5.1.3(c); and
 - (iii) when using both clipped and pierced fastening systems-

Amdt 11

- (A) employ an anti-capillary feature in the side lap of the sheet, to prevent capillary action drawing moisture into the lap and allowing the lap to drain (achieved by not over tightening the sheet fixings, see Figure 3.5.1.3); and
- (B) wherever possible have the sheets laid so that the side lap is facing away from prevailing weather.

Table 3.5.1.2
ACCEPTABILITY OF CONTACT BETWEEN DIFFERENT ROOFING MATERIALS

Note:

1. No - means the metal cannot be used in association with the other metal.
2. Yes - means the metal can be used in association with the other metal.

CLADDING MATERIAL	ACCESSORY OR FASTENER MATERIAL							
	Stainless steel		Zinc-coated steel and Zinc		Zinc/Aluminium coated steel		Lead	
	Atmosphere Classification (S = Severe and M = Moderate environment as Per Table 3.5.1.1)							
	S	M	S	M	S	M	S	M
Copper and copper alloys	No	Yes	No	No	No	No	No	Yes
Stainless steel (300 series)	Yes	Yes	No	No	No	No	No	Yes
Zinc-coated steel and zinc	No	Yes	Yes	Yes	Yes	Yes	No	Yes
Zinc/aluminium coated steel	No	Yes	Yes	Yes	Yes	Yes	No	No
Lead	Yes	Yes	No	Yes	No	No	Yes	Yes

Amdt 11

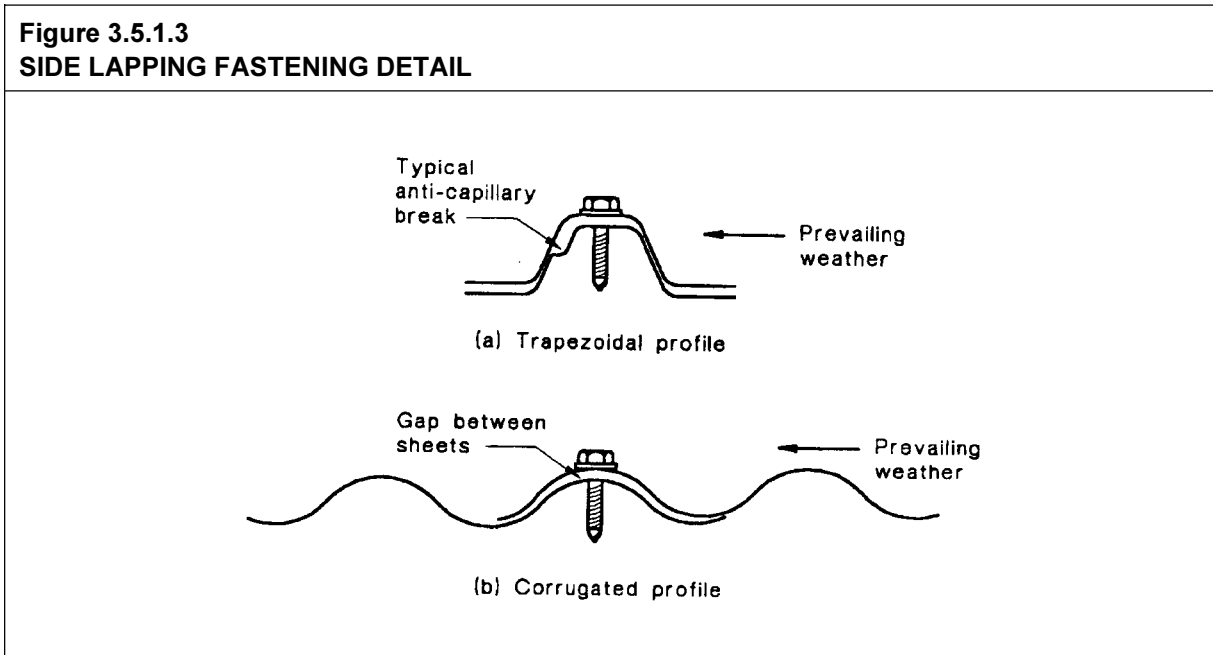

- (e) Sheets must be-
- (i) laid wherever possible using complete lengths from ridge to eaves; or
 - (ii) where a complete length cannot be laid-
 - (A) each run should be laid in specific sequence (see Figure 3.5.1.4) from bottom to top before moving on to the next run; and
 - (B) the distance for end lapping where sheets meet is-
 - (aa) for roof slopes between 5-15 degrees (1:12 - 1:4) - a lap of 200 mm; and
 - (bb) for roof slopes above 15 degrees (1:4) - a lap of 150 mm; and
 - (iii) stop ended (ie each valley turned up 60 degrees) at the ridge line of each length.

Figure 3.5.1.4
SHEET LAYING SEQUENCE

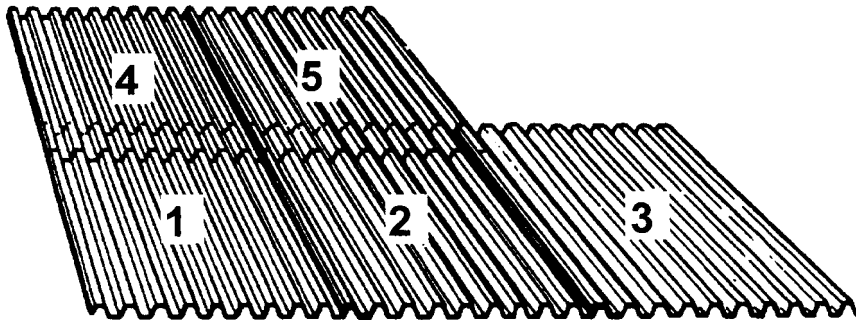

- (f) Metal sheet roofing must comply with the pitch and span limitations between roofing supports as shown in Figure 3.5.1.5.

**Figure 3.5.1.5
MAXIMUM SPAN AND FIXING FOR METAL SHEET ROOFING**

Note: The end span of some trapezoidal roofing systems may need to be reduced to 1.5 m (see proprietary information).

Diagram a. Typical profiles – Pitch is appropriate for a sheet run up to 25 m in length

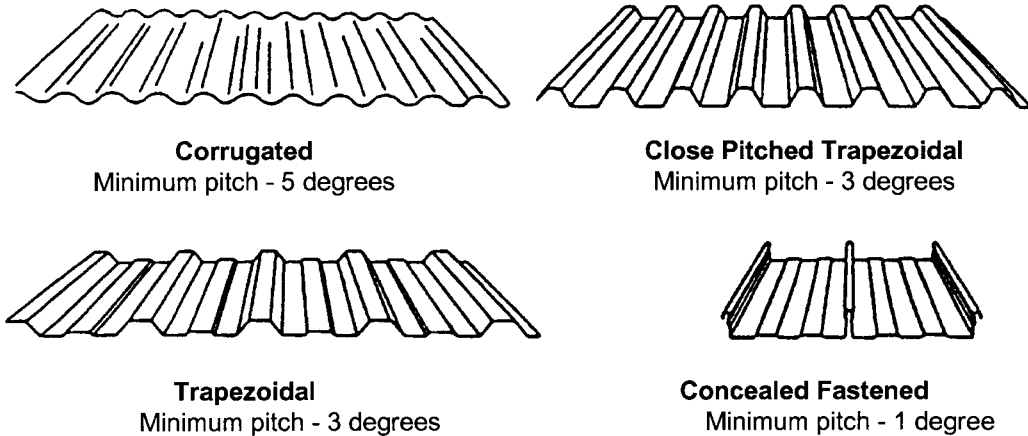
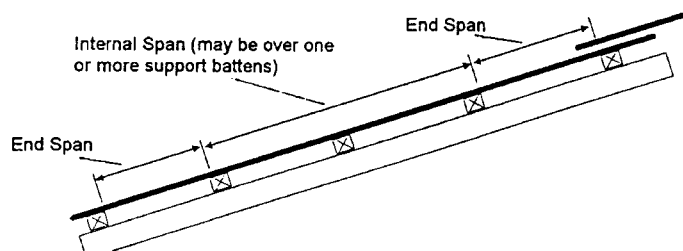

Diagram b. End and internal roof spans



Note: End span is also the end of sheets where they overlap with an adjoining sheet.

PROFILE	BASE METAL THICKNESS (mm)	END SPAN (mm)	INTERNAL SPAN (mm)	FIXING (crest fastening)	
				END SPAN	INTERNAL SPANS
Corrugated	0.42	950	1200	Every second rib	Every third rib
Close pitched trapezoidal	0.42	1900*	2400	Every rib	Every second rib
Trapezoidal	0.42	1350	1700	Every rib	
Concealed Fasteners	0.48	1800	2100	Every rib	

Amdt 11

- (g) Sheet metal roof *flashings* and cappings must comply with the following:
 - (i) Roof *flashings* and cappings must be purpose made, machine-folded sheet metal sections of materials compatible with all up and downstream metal roof covering materials in accordance with 3.5.1.3(c).
 - (ii) The type of fasteners for *flashings* and cappings must comply with 3.5.1.3(d).
 - (iii) The frequency of fastener fixings for transverse *flashings* and cappings must comply with Table 3.5.1.3.

Table 3.5.1.3 FASTENER FREQUENCY FOR TRANSVERSE FLASHINGS AND CAPPINGS		
ROOF TYPE	FIXING FREQUENCY	FASTENER TYPE
Concealed fastened roofs	Every rib	Rivets and self drilling screws
Pierced fastened roofs	Every 2nd Rib	Self drilling screws or rivets
Corrugated roofs	Every 4th Rib	Self drilling screws or rivets

- (iv) Joints in *flashing* and cappings must be not less than 25 mm, fastened at intervals not more than 40 mm and lapped in the direction of the fall of the roof.
- (v) Wall and step *flashings* must be fastened into masonry walls with galvanised or zinc/aluminium sheet metal wedges at each end of each length and at intermittent intervals of not more than 500 mm and must overlap by not less than 75 mm in the direction of flow.
- (vi) Lead *flashings* must not be used with prepainted steel or zinc/aluminium steel or on any roof if the roof is part of a potable (drinking) water catchment area.
- (vii) Anti capillary breaks must be installed in accordance with Figure 3.5.1.6 and be-
 - (A) for flat surfaces - 10 mm/30 degree fold; and
 - (B) all other surfaces - 10 mm/90 degree or 135 degree fold.

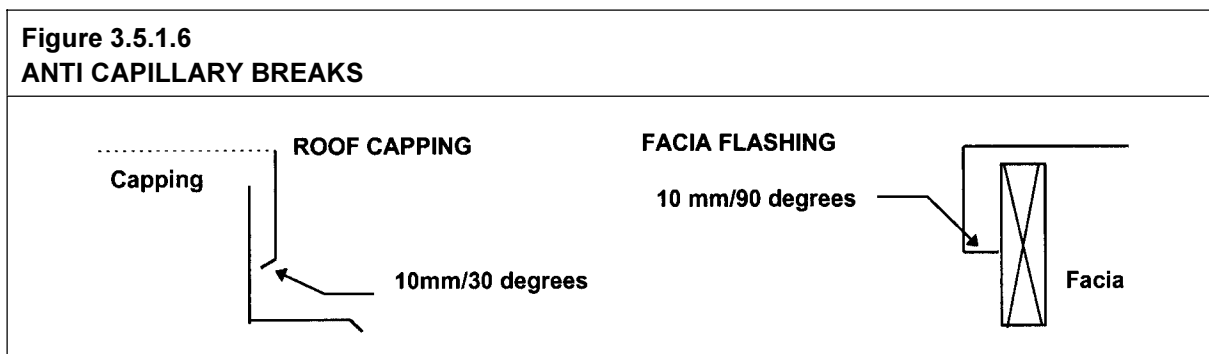

(viii) Acceptable *flashing* configurations are shown in Figure 3.5.1.7.

Fig 3.5.1.7
Amdt No. 11

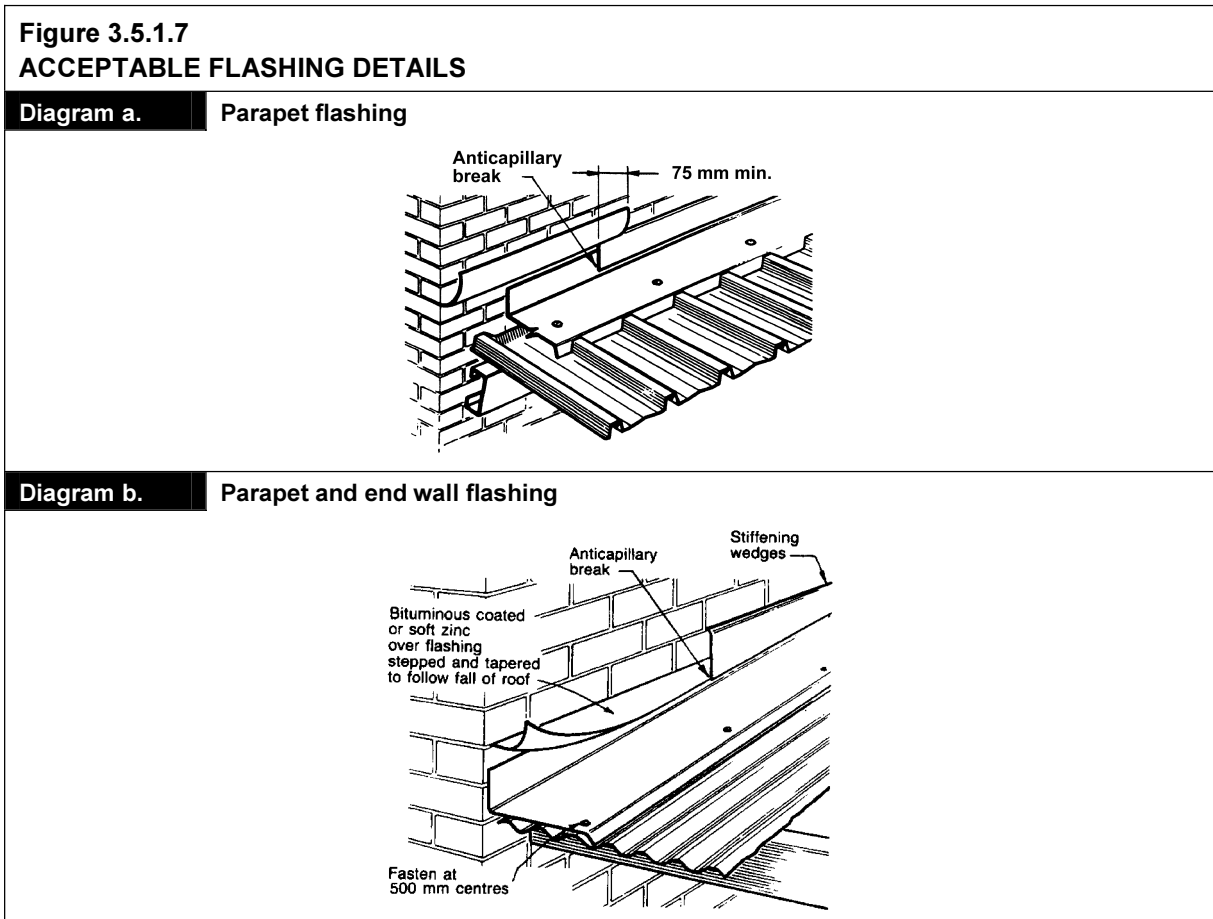

Amdt 11

- (h) *Flashing* of penetrations must comply with the following:
- (i) Collar *flashings* must permit the total drainage of the area above the penetration.
 - (ii) On the completion of installation, the roof structure must be restored to its original strength by installing roof trimmers and soaker supports as necessary.
 - (iii) The type of fasteners for *flashings* and cappings must comply with 3.5.1.3(d).
 - (iv) Lead *flashings* must not be used with prepainted steel or zinc/aluminium steel or on any roof if the roof is part of a potable water catchment area.
 - (v) Acceptable *flashings* for penetrations are shown in Figure 3.5.1.8.
 - (vi) Clearance for heating appliance roof support members must be in accordance with Part 3.7.3.

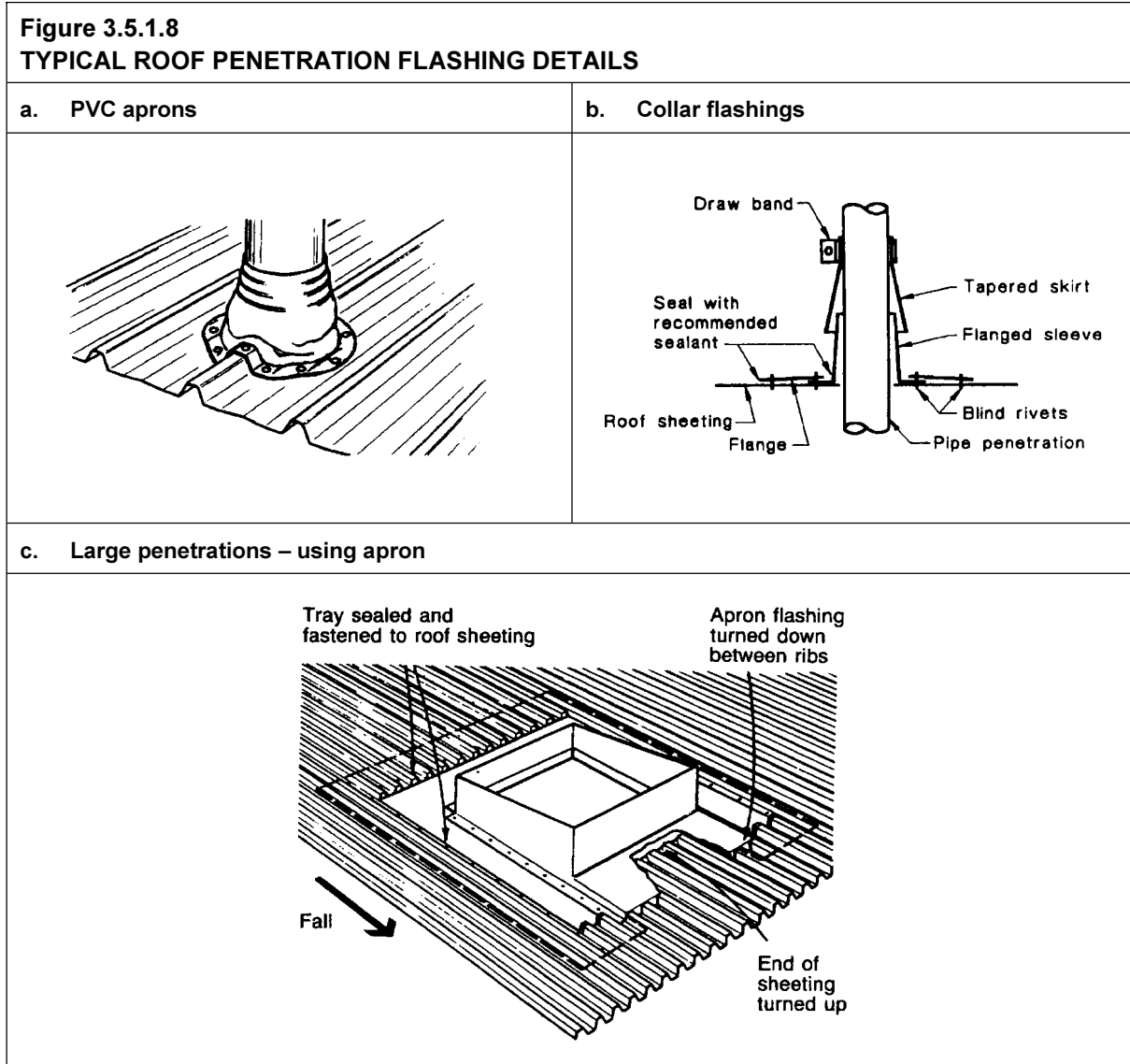

Amdt 11

PART 3.5.2 GUTTERS AND DOWNPIPES

Appropriate Performance Requirements:

Where an alternative gutter and downpipe system is proposed to that described in Part 3.5.2, that proposal must comply with *Performance Requirement P2.2.1* in Section 2.

A. Acceptable construction manual

3.5.2.0 *Performance Requirement P2.2.1* is satisfied for gutters and downpipes if they are designed and constructed in accordance with AS/NZS 3500.3.2 - Stormwater drainage, or AS/NZS 3500.5 – Domestic installations, Section 5 – Stormwater drainage.

3.5.2.0
Amdt No. 8

Amdt 11

B. Acceptable construction practice

3.5.2.1 Application

Compliance with this Part satisfies *Performance Requirement P2.2.1* for gutters and downpipes provided-

- (a) the roof drainage system is connected to a stormwater drainage system that complies with Part 3.1.2; and
- (b) the roof drainage system is designed so that any overflow during heavy rain periods is prevented from flowing back into the building.

Explanatory information:

1. The requirement to install drainage systems from roofs and sub-soil drains should be confirmed with the *appropriate authority*. These provisions need only be applied when drainage systems are necessary.
2. Information on drainage requirements outside the allotment can be obtained from the *appropriate authority*.

3.5.2.2 Materials

Amdt No. 9

Gutters, downpipes and *flashings* must be manufactured in accordance with-

- (a) AS/NZS 2179.1 for metal; and
- (b) AS 1273 for UPVC components; and
- (c) be compatible with all upstream roofing materials in accordance with 3.5.1.3(c).

3.5.2.3 Selection of guttering

The size of guttering must-

- (a) be in accordance with Table 3.5.2.2; and
- (b) be suitable to remove rainwater falling at the appropriate rainfall intensity listed in Table 3.5.2.1 as follows-
 - (i) for eaves gutters - 20 year *average recurrence interval*; or
 - (ii) for internal box and valley gutters - 100 year *average recurrence interval*.

3.5.2.4 Installation of gutters

- (a) Gutters must be installed with a fall of not less than-
 - (i) 1:500 for eaves gutters, unless fixed to metal facias; and
 - (ii) 1:100 for box gutters.
- (b) Eaves gutters must be supported by brackets securely fixed at stop ends and at not more than 1.2 m centres.
- (c) Valley gutters on a roof with a pitch-
 - (i) more than 12.5 degrees - must have width of not less than 400 mm and be wide enough to allow the roof covering to overhang not less than 150 mm each side of the gutter; or
 - (ii) not more than 12.5 degrees - must be designed as a box gutter.

3.5.2.4(c)
Amdt No. 2

3.5.2.5 Downpipes - size and installation

- (a) Downpipes must be securely fixed to walls.
- (b) The spacing between downpipes must not be more than 12 m.
- (c) Downpipes must be fixed as close as possible to valley gutters and, if the downpipe is more than 1.2 m from a valley, provision for overflow must be made.
- (d) Where high-fronted gutters are installed, provision must be made to avoid any overflow from flowing back into the roof or building structure by installing slotted gutters or the like.
- (e) Downpipes must-
 - (i) be compatible with other roofing materials used in the roofing system in accordance with 3.5.1.3(c); and
 - (ii) be selected in accordance with appropriate eaves gutter section as shown in Table 3.5.2.2.

3.5.2.5(d)
Amdt No. 2

Table 3.5.2.1
Amdt No. 4

Table 3.5.2.1					
RAINFALL INTENSITIES					
Locality	5 minute rainfall intensity (mm/h)		Locality	5 minute rainfall intensity (mm/h)	
	<i>Average recurrence interval, once in -</i>			<i>Average recurrence interval, once in -</i>	
	20 years	100 years		20 years	100 years
<u>ACT</u>			<u>SA</u>		
Canberra	137	194	Adelaide	123	186
<u>NSW</u>			Mt Gambier	108	168
Albury	135	191	Murray Bridge	117	181
Broken Hill	130	181	Port Augusta	124	189
Goulburn	145	197	Port Pirie	125	201
Kiama	224	283	Yorktown	118	197
Newcastle	181	233	<u>WA</u>		
Orange	152	214	Albany	142	217
Sydney	214	273	Broome	252	343
Tweed Heads	245	303	Bunbury	148	215
Wollongong	233	294	Derby	254	343
<u>VIC</u>			Geraldton	132	173
Ballarat	127	184	Kalgoorlie	116	180
Benalla	133	187	Perth	146	214
Geelong	118	172	Port Hedland	233	332
Horsham	120	174	Tom Price	164	222
Lakes Entrance	124	179	<u>TAS</u>		
Melbourne	127	186	Burnie	118	191
Mildura	125	174	Flinders Island	128	184
Stawell	127	185	Hobart	99	155
<u>QLD</u>			Launceston	101	150
Brisbane	251	333	Queenstown	118	183
Bundaberg	241	318	St. Marys	205	266
Cairns	282	368	<u>NT</u>		
Cape York	301	388	Alice Springs	139	204
Cloncurry	172	228	Darwin	285	366
Innisfail	254	323	Katherine	230	304
Mackay	273	363			
Mt Isa	169	223			
Noosa	253	320			
Rockhampton	248	336			
Toowoomba	189	251			
Townsville	260	346			
Weipa	293	370			

Amdt 11

Table 3.5.2.2 GUTTER AND DOWNPIPE SELECTION					
Table a. Gutter sizes for various rainfall intensities and roof catchment areas per downpipe					
Design Rainfall Intensity (mm/h) (as per Table 3.5.2.1)	Roof Catchment Area per Downpipe - m ²				
	30	40	50	60	70
	Size of Gutter Required to Drain Roof Catchment Area into One (1) Downpipe (A, B, C, D, E and F defined in Table b.)				
90	A or C	A or C	A or C	A or C	A or C
120	A or C	A or C	A or C	A or C	A or D
140	A or C	A or C	A or C	A or D	B or E
160	A or C	A or C	A or C	A or E	B or E
175	A or C	A or C	A or D	B or E	E
200	A or C	A or C	A or D	B or E	F
225	A or C	A or C	A or B	E	F
255	A or C	A or D	B or E	E	F
275	A or C	A or D	B or E	F	F
325	A or C	B or E	F	F	F
425	A or C	E	F	F	F

**Table b
Amdt No. 8**

Table b. Gutter sizes for various rainfall intensities		
Gutter Type (as per Table a.)	Gutter description	Minimum Cross Sectional Area mm ²
A	Medium Rectangular Gutter	6500
B	Large Rectangular Gutter	7900
C	115 mm D Gutter	5200
D	125 mm D Gutter	6300
E	150 mm D Gutter	9000
F	Gutter must be designed in accordance with AS/NZS 3500.3.2 or Section 5 of AS/NZS 3500.5	

Table c. Downpipe selection					
Down pipe Section	Gutter Sections - (as per Table b.)				
	A	B	C	D	E
75 mm dia.	Yes	Yes	Yes	Yes	No
100 mm x 50 mm	Yes	Yes	Yes	Yes	Yes
90 mm dia.	Yes	Yes	Yes	Yes	Yes
100 mm x 75 mm	Yes	Yes	Yes	Yes	Yes

Legend: Yes - downpipe is suitable for the eaves gutter selection; and
No - downpipe is not suitable for the eaves gutter selection.

Amdt 11

Expl. Info.
Amdt No. 4

Explanatory information:

Stormwater drainage systems specified in the *Housing Provisions* are not designed to remove all of the water during exceptionally heavy rain, especially in tropical areas. Accordingly, it is necessary to design and install the system so that when overflowing occurs any water is directed away in a manner which ensures it does not pond against, or enter into, the building.

This may be achieved by using slotted gutters, oversized gutters and downpipes, locating the gutter so that it is below the top edge of the fascia or the installation of rainwater heads with overflow slots.

The installation of downpipes, especially near valley gutters, are designed to ensure rainwater from areas on the roof that have concentrated water flows perform adequately. If downpipe spacings are to be increased, allowance for overflow should be considered.

Consideration needs to be given to box gutters, valley gutters etc located above the internal areas of a building. In these situations if adequate overflow controls cannot be implemented there may be a need to increase the size and capacity of drainage components to remove all water anticipated during heavy rain periods.

There are many options available to designers using the requirements of the *Housing Provisions*. The designer will need to choose an overflow system that will cope with the expected rain intensity, ie in heavy downpours a slotted gutter may be inadequate.

Amdt 11

PART 3.5.3 WALL CLADDING

Appropriate Performance Requirements:

Where an alternative wall cladding is proposed to that described in Part 3.5.3, that proposal must comply with *Performance Requirements* P2.1 and P2.2.2 in Section 2.

Acceptable construction practice

3.5.3.1 Application

Compliance with this Part satisfies *Performance Requirements* P2.1 and P2.2.2 for wall cladding provided-

- (a) the building is located in an area with a *design wind speed* of not more than W41; and

Explanatory information:

1. Information on *design wind speeds* for particular areas may be available from the *appropriate authority*.
2. A map indicating cyclonic regions of Australia is contained in Part 3.10.1.
3. For wall cladding in areas with a *design wind speed* of more than W41 refer to the appropriate design manual listed in Part 3.11.

- (b) wall cladding is installed in accordance with-
 - (i) 3.5.3.2 for timber weatherboard cladding; and
 - (ii) 3.5.3.3 for fibre cement planks and weatherboard cladding; and
 - (iii) 3.5.3.4 for fibre cement sheet and plywood sheet cladding; and
- (c) fibre cement sheet eaves are installed in accordance with 3.5.3.5; and
- (d) openings in cladding are flashed in accordance with 3.5.3.6.

3.5.3.2 Timber weatherboard cladding

Timber cladding must be installed as follows:

- (a) Splayed timber weatherboards must be fixed in accordance with Figure 3.5.3.1 and with a lap not less than-
 - (i) 30 mm for hardwood, cypress and treated pine; and
 - (ii) 20 mm for western red cedar; and

- (iii) 25 mm for baltic pine.
- (b) Profiled timber boards must be-
 - (i) fixed with the overlap and groove closely fitted; and
 - (ii) with tongue and groove profile, fixed tongue edge up.
- (c) Spacing of fixings must be-
 - (i) one nail per board at each stud at not more than 650 mm centres measured along the board; and
 - (ii) nailed so that they do not penetrate the tip or thinner edge of the board beneath, ie for 30 mm lap, nail 35 mm from the butt (see Figure 3.5.3.1).
- 3.5.3.3(d)**
Amdt No. 9 (d) Nails used to fix timber cladding must comply with the following:
 - (i) Where nails are punched and filled prior to painting, with standard steel bullet-head nails.
 - (ii) Uncoated copper or steel nails must not be used for western red cedar (silicon bronze, monel metal, stainless steel or hot-dipped galvanised are suitable).
 - (iii) In all other cases, nails must be hot-dipped galvanised flat head or bullet head.
- (e) Acceptable nail sizes are-
 - (i) for hardwood and cypress frames - 50x2.8 mm plain shank; and
 - (ii) for softwood frames - 50x3.15 mm annular threaded.

3.5.3.3 Fibre cement planks and weatherboard cladding

Fibre cement plank and weatherboard cladding must be installed as follows:

- 3.5.3.3(a)**
Amdt No. 9 (a) 7.5 mm (minimum) fibre cement planks and weatherboards must be-
 - (i) manufactured in accordance with AS/NZS 2908.2 or ISO 8336; and
 - (ii) fixed with a lap of not less than 25 mm (see Figure 3.5.3.1).
- (b) 7.5 mm (minimum) fibre cement planks and weatherboards must be fixed in accordance with Figure 3.5.3.1 with a stud spacing of not more than 600 mm.
- (c) Acceptable fixings for 7.5 mm fibre cement planks and weatherboards are-
 - (i) for timber studs - 40x2.8 mm galvanised fibre cement nails; and
 - (ii) for steel studs - 8-18x35 mm self embedding head screws (see Figure 3.5.3.1).

**Figure 3.5.3.1
FIXING OF WALL CLADDING**

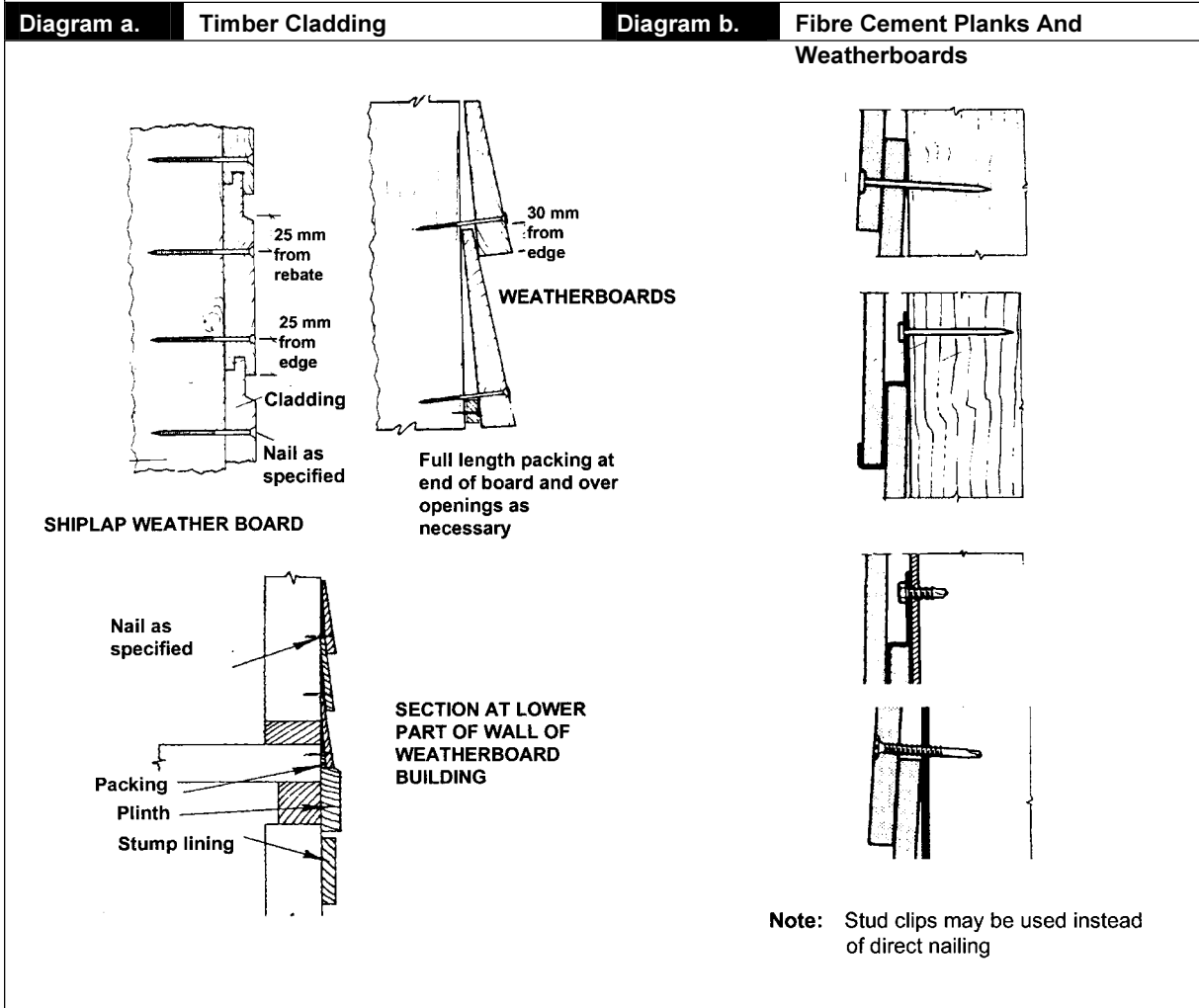

Amdt 11

3.5.3.4 Sheet wall cladding

3.5.3.4(a)
Amdt No. 9

- (a) Fibre cement sheets must comply as follows:
- (i) Fibre cement sheets used as external wall cladding must be fixed in accordance with Table 3.5.3.1 and Figure 3.5.3.2.
 - (ii) Where the external cladding also acts as structural sheet bracing, the lesser of the stud and fixing spacings for both applications must be used.
 - (iii) External fibre cement sheets and claddings must comply with AS/NZS 2908.2 or ISO 8336.

**Table 3.5.3.1
STUD AND WALL SPACINGS FOR 6mm FIBRE CEMENT SHEET WALL CLADDING**

Design wind speed	STUD SPACING		NAIL SPACING (2.8 mm fibre cement nails)			
	Within 1.2 m of ends of building	Elsewhere	Within 1.2 m of ends of building		Elsewhere	
			Body	Edges	Body	Edges
W28	600	600	300	200	300	200
W33	600	600	200	200	300	200
W41	450	600	200	200	200	200

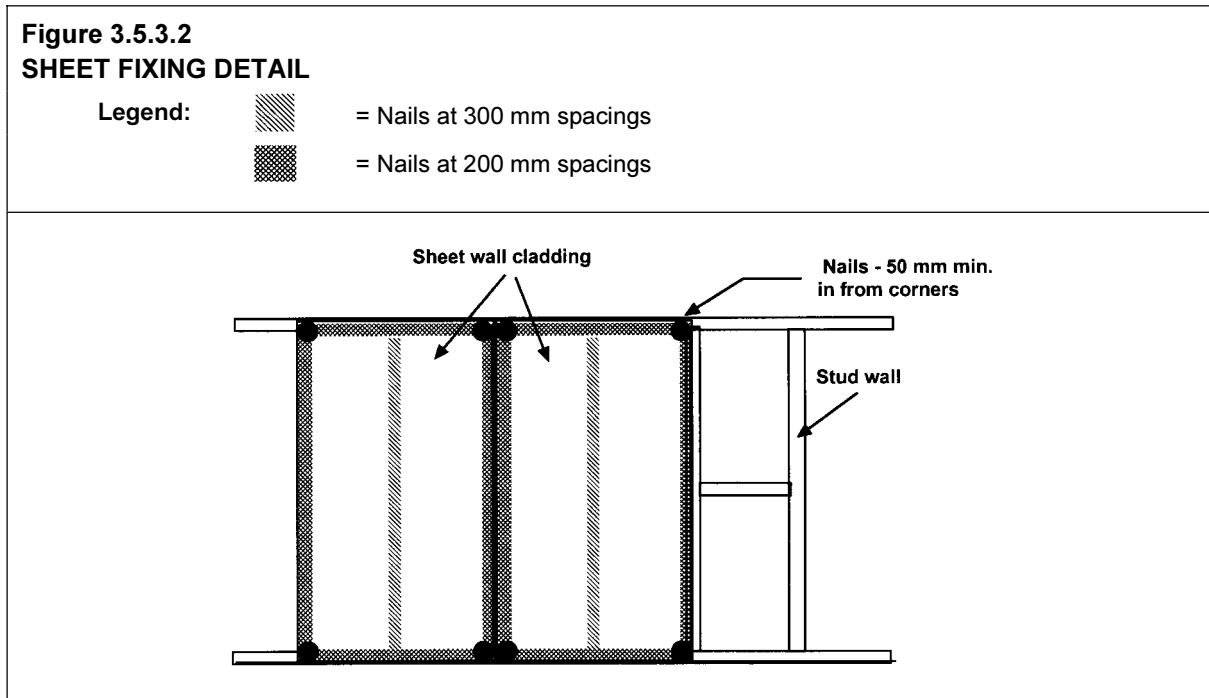

- 3.5.3.4(b)**
Amdt No. 9
- (b) Structural plywood external cladding must comply as follows:
- (i) Structural plywood cladding must comply with AS/NZS 2269.
 - (ii) Where structural plywood acts as cladding and combined structural bracing it must comply with Table 3.5.3.2.
 - (iii) Sheets, not more than 9 mm thick must be fixed using 2.8/3.5x30 mm long galvanised clouts or flat head nails spaced at-
 - (A) 150 mm centres along sheet edges; and

- (B) 300 mm for intermediate fixings; and
- (iv) Sheets thicker than 9 mm must be fixed with 2.8 or 3.5 mm galvanised clouts or flat head nails with a length calculated using the following formula:

$$\text{MIN NAIL LENGTH } L = PL + 10 Da$$

Where PL = Plywood thickness and

Da = Diameter of nail

- (v) The fixings must be located not less than 9 mm from the edge of the sheet.

Explanatory information:

The above formula is applied as follows:

For 12 mm plywood and 2.8 mm diameter nail

$L = 12 + 28 \text{ mm}$; therefore the nail length must be 40 mm.

Amdt 11

Table 3.5.3.2 MINIMUM STRUCTURAL PLYWOOD THICKNESS FOR COMBINED BRACING AND EXTERNAL CLADDING (mm)						
Plywood stress grade	Stud spacing (mm)					
	Plywood face grain Parallel to studs			Plywood face grain At right angles to studs		
	450	600	900	450	600	900
F8	9	12	16	7	9	12
F11	8	12	16	6	8	12
F14	7	12	16	6	7	12

3.5.3.5 Eaves and soffit linings

External fibre cement sheets and linings used as eaves and soffit linings must-

3.5.3.5(a)
Amdt No. 9

- (a) comply with AS/NZS 2908.2 or ISO 8336; and
- (b) be fixed in accordance with Table 3.5.3.3 and Figure 3.5.3.3 using-
 - (i) 2.8x30 mm Fibre cement nails; or
 - (ii) No. 8 Wafer head screws (for 4.5 mm and 6 mm sheets only); or
 - (iii) No. 8 Self embedding head screws (for 6 mm sheets only).

**Table 3.5.3.3
TRIMMER AND FASTENER SPACINGS FOR 4.5 AND 6 mm FIBRE CEMENT EAVES AND SOFFIT LININGS**

Maximum eaves Width	Design wind speed	Maximum Trimmer spacings (mm)		Maximum Fastener Spacings (mm)	
		Within 1200 mm of the external corners of the building	Remainder of sheet	Within 1200 mm of the external corners of the building	Remainder of sheet
600	W28	600	900	200	300
	W33	600	800	200	300
	W41	500	700	200	300
1200	W28	600	750	200	300
	W33	600	700	200	300
	W41	500	650	200	300

Amdt 11

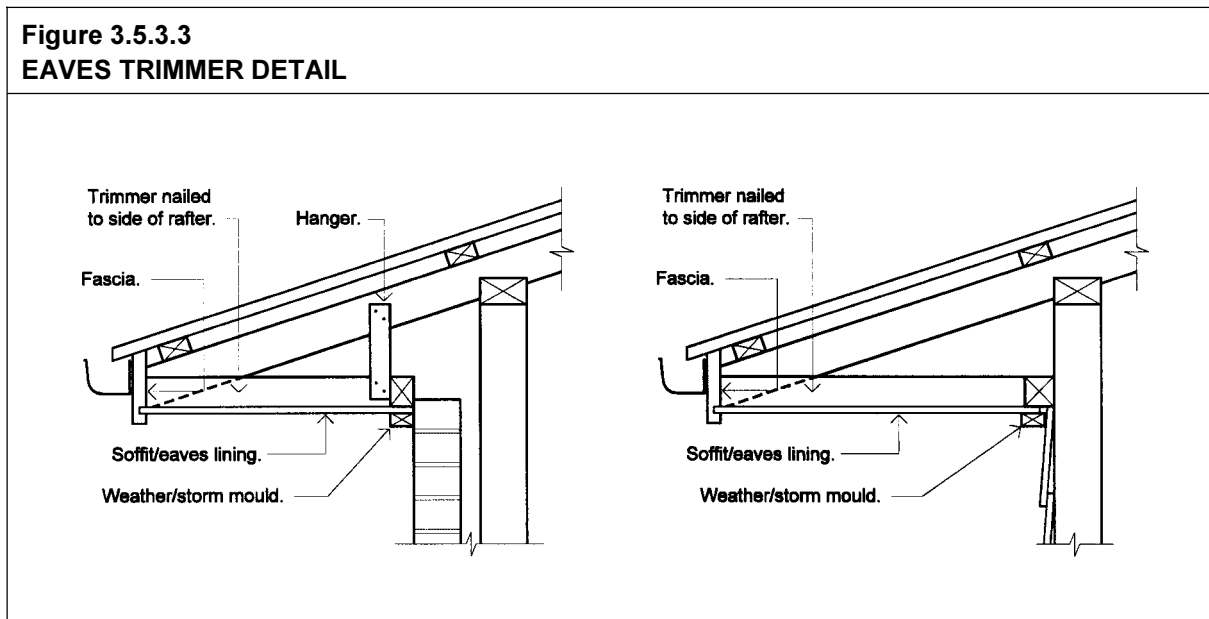

3.5.3.6 Flashings to wall openings

Openings in external wall cladding exposed to the weather must be flashed as follows:

- 3.5.3.6(a)**
Amdt No. 9 (a) All openings must be adequately flashed using materials that comply with AS/NZS 2904.

- (b) *Flashings* must be securely fixed at least 25 mm under the cladding and extend over the ends and edges of the framing of the opening (see Figure 3.5.3.4).

Figure 3.5.3.4
TYPICAL WINDOW FLASHING DETAIL

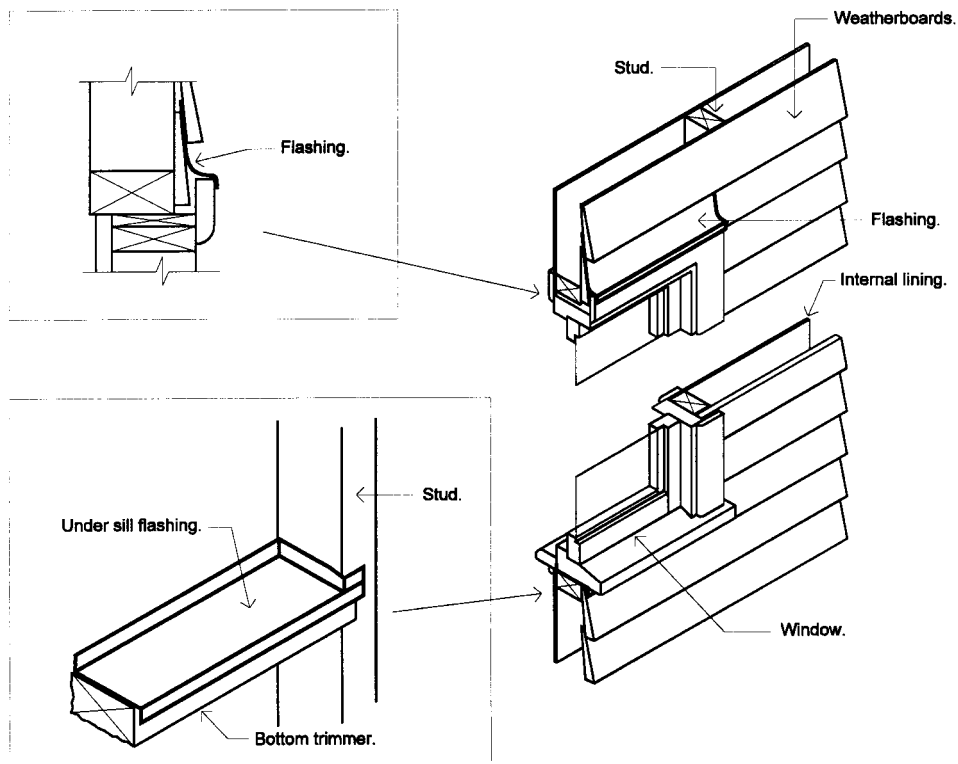

Amdt 11

PART 3.6**Amdt 11**

GLAZING

- 3.6 Definitions**
 - 3.6.0 Acceptable Construction Manual**
 - 3.6.1 Application**
 - 3.6.2 Glazing Sizes and Installation**
 - 3.6.3 Perimeter Framed Glazing**
 - 3.6.4 Human Impact Safety Requirements**
 - 3.6.5 Doors**
 - 3.6.6 Side Panels**
 - 3.6.7 Full Height Framed Glazed Panels**
 - 3.6.8 Glazed Panels, Other than Doors or Side Panels, on the Perimeter of Rooms**
 - 3.6.9 Shower Doors, Shower Screens and Bath Enclosures**
-

PART 3.6 CONTENTS

		Page
3.6	Glazing	15,021
3.6	Definitions	
3.6.0	Acceptable construction manual	
3.6.1	Application	
3.6.2	Glazing sizes and installation	
3.6.3	Perimeter framed glazing	
3.6.4	Human impact safety requirements	
3.6.5	Doors	
3.6.6	Side panels	
3.6.7	Full height framed glazed panels	
3.6.8	Glazed panels, other than doors or side panels, on the perimeter of rooms	
3.6.9	Shower doors, shower screens and bath enclosures	

PART 3.6 GLAZING

Appropriate Performance Requirements:

Where an alternative glazing system is proposed to that described in Part 3.6, that proposal must comply with *Performance Requirements* P2.1 and P2.2.2 in Section 2.

Definitions

3.6 The following definitions are used in this Part:

Perimeter of building means the external envelope of a building.

Unobstructed opening means a glazed area that a person could mistake for an open doorway or clearway and walk into the glazed panel.

A. Acceptable construction manuals

3.6.0 *Performance Requirements* P2.1 and P2.2.2 are satisfied for glazing and windows if designed and constructed in accordance with one of the following manuals:

3.6.0
Amdt No. 11

- (a) AS 2047 for the following glazed assemblies in an external wall:
 - (i) Windows excluding those listed in (b).
 - (ii) Sliding doors with a frame.
 - (iii) Adjustable louvres.
 - (iv) Window walls with one piece framing.
- (b) AS 1288 for all glazed assemblies not covered by (a) and the following glazed assemblies:
 - (i) All glazed assemblies not in an external wall.
 - (ii) Hinged doors, including French doors and bi-fold doors.
 - (iii) Revolving doors.
 - (iv) Fixed louvres.
 - (v) Skylights, roof lights and windows in other than the vertical plane.
 - (vi) Sliding doors without a frame.
 - (vii) Windows constructed on site and architectural one-off windows, which are not design tested in accordance with AS 2047.
 - (viii) Second-hand windows, re-used windows, recycled windows and replacement windows.
 - (ix) Heritage windows.

Expl. Info
Amdt No. 11

Explanatory information:

The reference to heritage windows in 3.6.0(b)(ix) is intended to apply to windows in heritage buildings. The method of determining a heritage building is normally covered by the relevant State or Territory authority.

Qld var.
Amdt No. 9

STATE AND TERRITORY VARIATIONS

3.6.0(a) is replaced by the following clause in Queensland:

- (b) AS 2047 for the following glazed assemblies in an external wall, with the exception that Tables 2.1 and 2.5 of AS 2047 are omitted and the following Tables are inserted:
 - (i) Windows excluding those listed in (b).
 - (ii) Sliding doors with a frame.
 - (iii) Adjustable louvres.
 - (iv) Window walls with one piece framing.

TABLE 2.1	
WINDOW RATINGS FOR HOUSING	
Window rating	Serviceability design wind pressure, Pa
N1	500
N2	700
N3, C1	1000
N4, C2	1500
N5, C3	2200
N6, C4	3000

TABLE 2.5	
ULTIMATE STRENGTH TEST PRESSURES	
Window rating	Ultimate strength test pressure, Pa
N1	700
N2	1000
N3, C1	1500
N4, C2	2300
N5, C3	3300
N6, C4	4500

Amdt 11

B. Acceptable construction practice
--

3.6.1 Application

Compliance with this Part satisfies *Performance Requirements* P2.1 and P2.2.2 for glazing, provided-

- (a) the building is located in an area with a *design wind speed* of not more than W41; and

Expl. Info.
Amdt No. 6

Explanatory information:

1. Information on *design wind speeds* for particular areas may be available from the *appropriate authority*.
2. For glazing in *high wind areas* refer to Part 3.10.1.

- (b) glass is manufactured in accordance with AS 1288; and
- (c) safety glazing must be legibly marked in accordance with AS 1288; and
- (d) glazing used in balustrades and sloped overhead glazing complies with AS 1288.

3.6.2 Glazing sizes and installation

Glazing used in buildings must comply with the following:

- (a) Glazing used in the *perimeter of buildings* and supported on all sides must comply with the appropriate provisions listed in 3.6.3.
- (b) Glazing used in areas where the potential for human impact could occur must comply with the appropriate provisions listed in 3.6.4.

3.6.3 Perimeter framed glazing (supported on all sides)

Glazing installed in the *perimeter of buildings* must comply with-

- (a) for ordinary annealed fully framed glass - Table 3.6.1 (see also Figure 3.6.2); and
- (b) for ordinary annealed patterned fully framed glass - Table 3.6.1.

Explanatory information:

For other types of perimeter glazing including toughened, wired, laminated and unframed glazing refer to AS 1288.

Amdt 11

Table 3.6.1			
FULLY FRAMED GLASS - MAXIMUM AREAS IN SQUARE METRES			
Minimum nominal thickness (mm)	<i>Design Wind Speed</i>		
	W28	W33	W41
Ordinary annealed fully framed glass			
3	2.0	1.4	1.0
4	3.5	2.4	1.7
5	5.2	3.6	2.6
6	7.4	5.2	3.6
8	11.0	7.9	5.4
Ordinary annealed, patterned, fully framed glass			
3	1.7	1.1	0.8
4	3.0	2.1	1.5
5	4.8	3.3	2.4
6	6.6	4.8	3.5

Amdt 11

3.6.4 Human impact safety requirements

The thickness and type of glazing installed in areas of a building that have a high potential for human impact (an area of a building frequented by the occupants during everyday activities in which a person could fall into or against the glazed panel) must comply as follows:

- (a) Doors - in accordance with 3.6.5.
- (b) Door side panels - in accordance with 3.6.6.
- (c) Full height glass panels - in accordance with 3.6.7.
- (d) Glazed panels, other than doors or side panels, on the perimeter of rooms - in accordance with 3.6.8.
- (e) Shower screens, shower doors and bath enclosures - in accordance with 3.6.9.

3.6.5 Doors

Glass (except leadlight panels) in doors must be Grade A safety glazing material in accordance with Table 3.6.3 and Figure 3.6.1, except that-

- (a) in fully framed panels, ordinary annealed glass with a maximum area of 0.5 m² in accordance with Table 3.6.4 may be used provided a chair rail not less than 40 mm wide is installed in the door; and
- (b) unframed doors must be glazed with toughened safety glass with a standard nominal thickness of not less than 10 mm; and
- (c) doors to showers and bath enclosures must be glazed in accordance with 3.6.9.

3.6.6 Side panels

3.6.6(a)
Amdt No. 9

- (a) All framed glass (except leadlight panels) in side panels with their nearest vertical sight line less than 300 mm from the nearest edge of the doorway opening must be of Grade A safety glazing material in accordance with Table 3.6.3 and Figure 3.6.1, except that-
- (i) where the lowest visible sight line is 1.2 m or greater above the highest abutting finished floor level, ordinary annealed glass in accordance with Table 3.6.2 may be used; or
 - (ii) where the lowest visible sight line is less than 1.2 m above the highest abutting finished floor level, ordinary annealed glass in accordance with Table 3.6.4, with an area of not more than 0.5 m², may be used; or
 - (iii) where the side panel consists of glass louvres with exposed edges or where the louvres are installed less than 500 mm above the highest abutting finished floor level-
 - (A) for blade widths not greater than 230 mm, Grade A toughened safety glazing not less than 5 mm thick; and
 - (B) for blade widths greater than 230 mm, Grade A toughened safety glazing not less than 10 mm thick.
- (b) Framed glass panels with the nearest vertical sight line not less than 300 mm from the nearest edge of the door opening are not considered to be side panels for the purposes of the *Housing Provisions*.

Amdt 11

Table 3.6.2	
MAXIMUM AREAS OF ORDINARY ANNEALED GLASS IN SIDE PANELS	
Minimum nominal thickness (mm)	Maximum area of pane (m ²)
3	0.8
4	1.4
5	2.2
6	3.3

3.6.7 Full height framed glazed panels

3.6.7(b)
Amdt No. 9

- (a) A glazed panel located in a building so that it is capable of being mistaken for an *unobstructed opening* must be glazed with-
- (i) Grade A safety glazing material in accordance with Table 3.6.3, or
 - (ii) ordinary annealed glass complying with Table 3.6.3 provided the glazed area is not greater than 0.9 m².
- (b) Glazed panels are not considered capable of being mistaken for an *unobstructed opening* where any of the following apply:
- (i) The clear opening width is not more than 500 mm.
 - (ii) The lowest sight line of the opening is not less than 500 mm above the highest abutting finished floor level.

- (iii) The glass is marked by means of a permanent motif or other decorative treatment on or etched into the glass, of sufficient magnitude to be readily apparent, or the glass is opaquely coloured or patterned to indicate its presence.
- (iv) A chair rail or handrail not less than 40 mm thick, or the like is provided at a height of 865 mm above the adjoining ground level.
- (v) Internal partitions clearly form walls of a passageway and conform with item (a).
- (vi) The difference in floor level on either side of the panel is greater than 500 mm.

Figure 3.6.1
Amdt No. 10

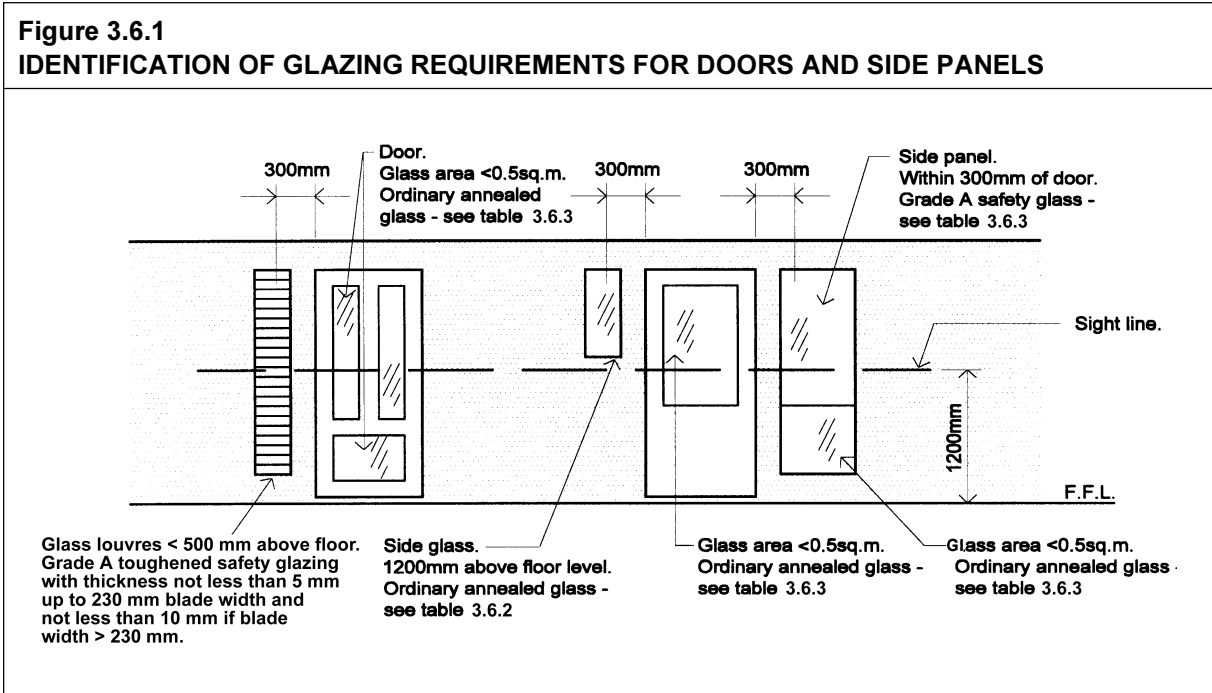

Amdt 11

TABLE 3.6.3
MAXIMUM AREAS OF GLAZING MATERIAL FOR FRAMED GLASS DOORS, FRAMED GLASS SIDE PANELS, AND OTHER FRAMED GLAZED PANELS

Type of Glass	Minimum nominal thickness (mm)	Maximum area of pane (m ²)
Patterned or clear ordinary annealed glass	3	0.1
	4	0.3
	5	0.5
	6	0.9
Grade A Toughened safety glass	3	1
	4	2
	5	3
	6	4
Grade A Laminated safety glass	5.38	2
	6.38	3
	8.38	5

3.6.8 Glazed panels, other than doors or side panels, on the perimeter of rooms

All framed glazing where the lowest sight line of the glazing panel is less than 500 mm from the highest abutting finished floor level must be-

- (a) Grade A safety glazing material in accordance with Table 3.6.3; or
- (b) ordinary annealed glass in accordance with Table 3.6.4 (see also Figure 3.6.2).

Table 3.6.4
Amdt No. 9

TABLE 3.6.4 MAXIMUM AREAS OF ORDINARY ANNEALED GLASS WHERE THE LOWEST SIGHT LINE IS LESS THAN 500 MM FROM THE HIGHEST ABUTTING FLOOR LEVEL	
Minimum nominal thickness (mm)	Maximum area of pane (m ²)
3	0.1
4	0.3
5	2.0

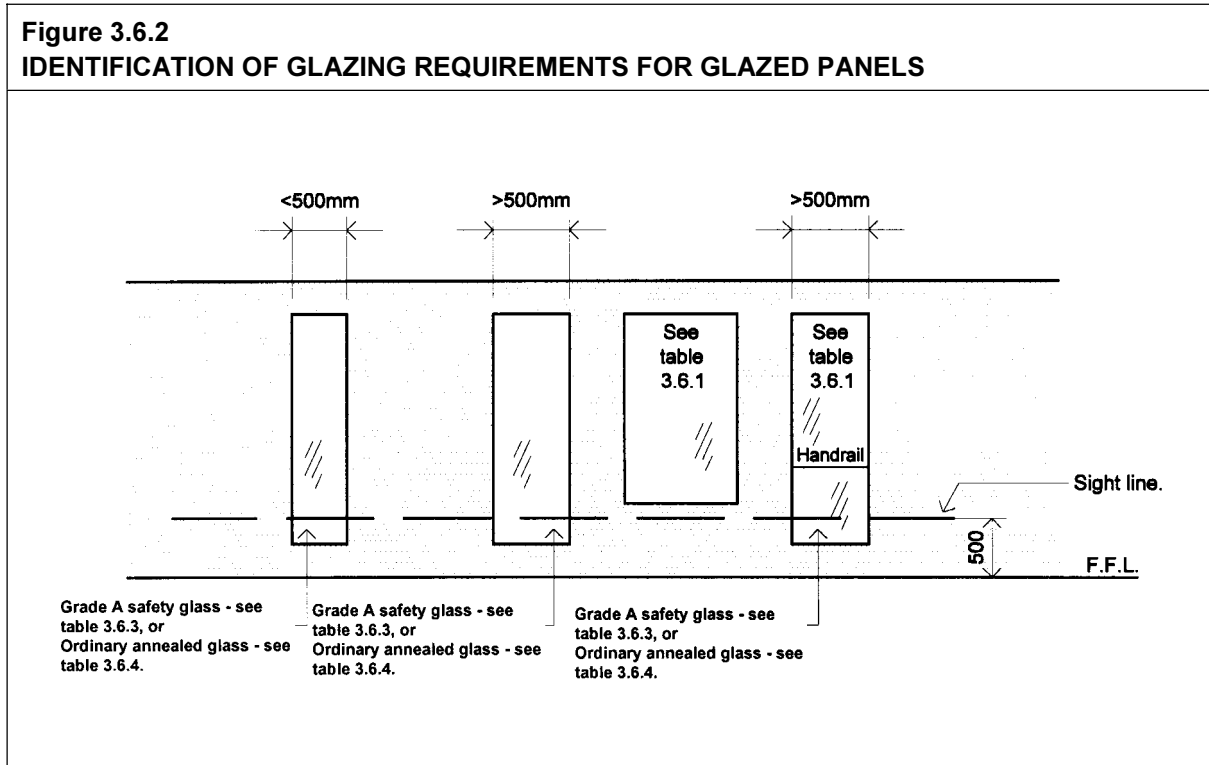

3.6.9 Shower doors, shower screens and bath enclosures

- (a) All shower doors, shower screens, bath enclosures, and associated *windows*, where the lowest sight line is less than 1.5 m above the highest abutting finished level of the floor, bottom of the bath, or shower base, must-
 - (i) for framed panels, be glazed with-
 - (A) Grade A safety glazing material in accordance with Table 3.6.3; or
 - (B) Grade B safety glazing material in accordance with Table 3.6.5; or
 - (ii) for panels or doors with any edge exposed must be toughened safety glass in accordance with Table 3.6.3 with a minimum nominal thickness of 5 mm.
- (b) For the purposes of this part-
 - (i) a *window* is part of a bath enclosure or shower if it is less than 500 mm horizontally from the internal perimeter of the floor of the bath or shower (see Figure 3.6.3); and
 - (ii) a *window* is not part of the bath or shower if a person in the bath or shower is protected from the *window* by permanent safety glazing or permanent material able to resist human impact.
- (c) Associated *windows* referred to in b) (i), in *external walls* may incorporate annealed glass panels of not less than 4 mm thickness, provided that they are not more than 0.1 m² in area.

Explanatory information:

Care should be taken when using showers fitted with safety wired glass, safety organic-coated glass, and laminated safety glass products that are liable to damage from thermal shock. Thermal shock occurs from hot water from the shower hitting the shower screen during cold weather.

TABLE 3.6.5 MAXIMUM AREAS OF GRADE B SAFETY GLAZING MATERIALS FOR SHOWER DOORS, SHOWER SCREENS AND BATH ENCLOSURES			
Type of Glass	Standard nominal thickness (mm)	Maximum area of pane (m ²)	Area (Fig. 3.6.3)
Safety wired glass	Greater than or equal to 6	2.5	A, B, C
Safety organic coated glass	3	1	A, B, C, D
	4	1.5	
	5	2	
	Greater than or equal to 6	3	

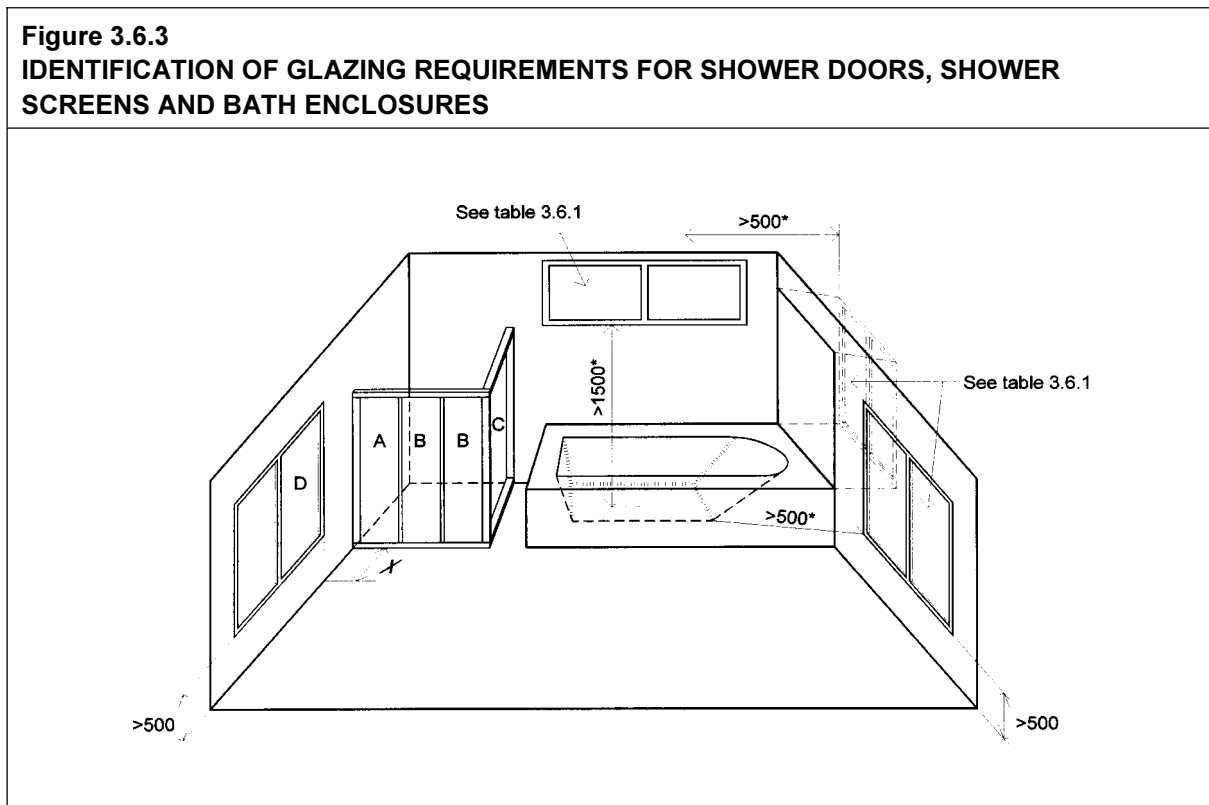

Amdt 11

PART **3.7**

Amdt 11

FIRE SAFETY

- 3.7.1 Fire Separation**
- 3.7.2 Smoke Alarms**
- 3.7.3 Heating Appliances**
- 3.7.4 Bushfire Areas**
- 3.7.5 Alpine Areas**

PART 3.7 FIRE SAFETY

	Page
3.7.1 Fire separation	17,021
3.7.1.1 Application	
3.7.1.2 General concession - non-combustible materials	
3.7.1.3 External walls of Class 1 buildings	
3.7.1.4 Measurement of distances	
3.7.1.5 Construction of external walls	
3.7.1.6 Class 10a buildings	
3.7.1.7 Allowable encroachments	
3.7.1.8 Separating walls	
3.7.1.9 Fire hazard properties	
3.7.1.10 Roof lights	
3.7.2 Smoke alarms	17,301
3.7.2.1 Application	
3.7.2.2 Requirements for smoke alarms	
3.7.2.3 Location - Class 1a buildings	
3.7.2.4 Location - Class 1b buildings	
3.7.2.5 Lighting to assist evacuation - Class 1b buildings	
Explanatory information - Smoke alarms	
3.7.3 Heating appliances	17,501
3.7.3.0 Acceptable construction manuals	
3.7.3.1 Application	
3.7.3.2 Open fireplace construction	
3.7.3.3 Chimney construction	
3.7.3.4 Installation of insert fireplaces and flues	
3.7.3.5 Installation of free standing heating appliances	
3.7.4 Bushfire areas	17,701
3.7.4.0 Acceptable construction manuals	
3.7.4.1 Application	
3.7.4.2 Categories of bushfire attack	
3.7.4.3 Construction requirements	
3.7.5 Alpine areas	17,901
3.7.5.1 Application	
3.7.5.2 External doorways	
3.7.5.3 External ramps	
3.7.5.4 Discharge of external doorways providing means of egress	
3.7.5.5 External trafficable structures	

PART 3.7.1 FIRE SEPARATION

Appropriate Performance Requirements:

Where an alternative fire separation design is proposed to that described in Part 3.7.1, that proposal must comply with *Performance Requirement P2.3.1* in Section 2.

Acceptable construction practice

3.7.1.1 Application

Compliance with this Part satisfies *Performance Requirement P2.3.1* for fire separation.

3.7.1.2 General concession - non-combustible materials

The following materials, though *combustible* or containing *combustible* fibres, may be used wherever a *non-combustible* material is required in the *Housing Provisions*-

- (a) plasterboard; and
- (b) perforated gypsum lath with a normal paper finish; and
- (c) fibrous-plaster sheet; and
- (d) fibre-reinforced cement sheeting; and
- (e) pre-finished metal sheeting having a *combustible* surface finish not exceeding 1 mm thick and where the *Spread-of-Flame Index* of the product is not more than 0; and
- (f) bonded laminated materials where-
 - (i) each laminate is *non-combustible*; and
 - (ii) each adhesive layer is not more than 1 mm thick; and
 - (iii) the total thickness of adhesive layers is not more than 2 mm; and
 - (iv) the *Spread-of-Flame Index* and the *Smoke-Developed Index* of the laminated material as a whole does not exceed 0 and 3 respectively.

3.7.1.2(c)
Amdt No. 9

3.7.1.3 External walls of Class 1 buildings

An *external wall* of a Class 1 building, and any openings in that wall, must comply with 3.7.1.5 if the wall is less than-

- (a) 900 mm from an allotment boundary other than the boundary adjoining a road alignment or other public space; or

- (b) 1.8 m from another building on the same allotment other than an appurtenant Class 10 building or a detached part of the same Class 1 building.

3.7.1.4 Measurement of distances

- (a) The distance from any point on an *external wall* of a building to an allotment boundary or another building is the distance to that point measured along a line at right angles from the allotment boundary or *external wall* of the other building which intersects that point without being obstructed by a wall complying with 3.7.1.5.
- (b) Where a wall within a specified distance is *required* to be constructed in a certain manner, only that part of the wall (including any openings) within the specified distance need be constructed in that manner.

(see Figure 3.7.1.1 and 3.7.1.2)

Figure 3.7.1.1
Amdt No. 11

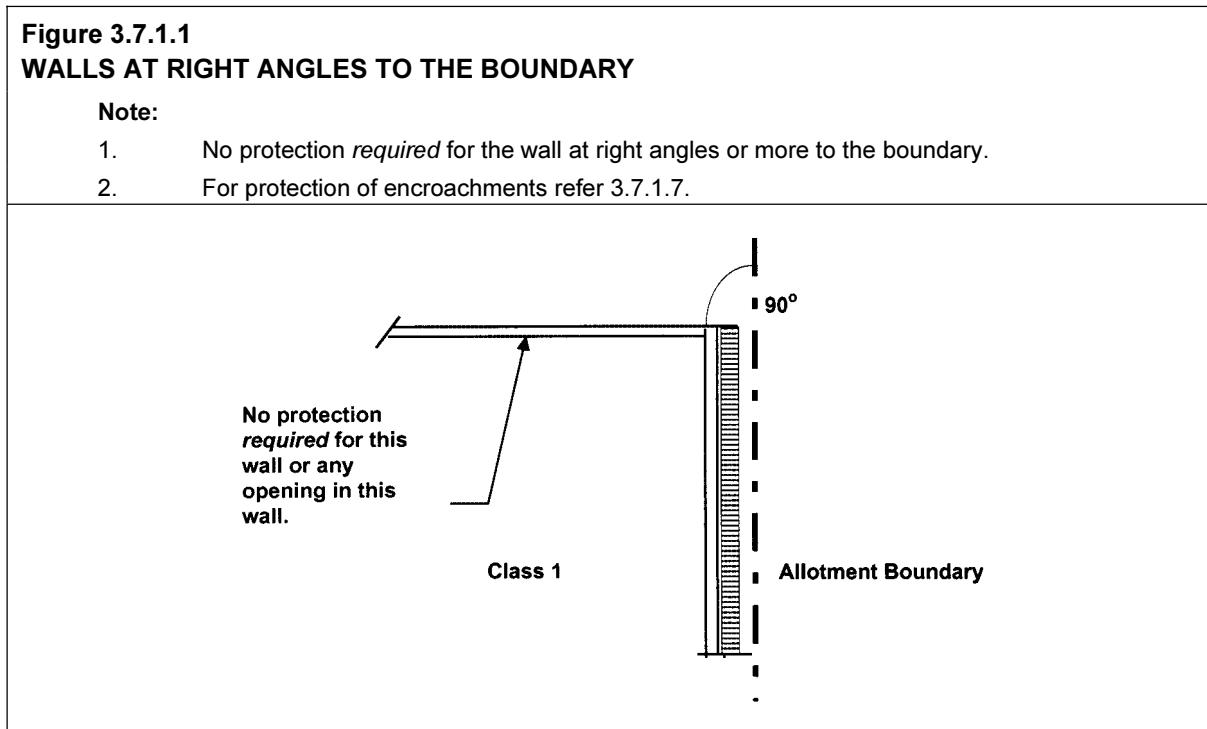

3.7.1.5 Construction of external walls

3.7.1.5
Amdt No. 10

- (a) *External walls* (including gables) *required* to be fire resisting (referred to in 3.7.1.3 or 3.7.1.6) must extend to the underside of a *non-combustible* roof covering or *non-combustible* eaves lining (See Figure 3.7.1.3(a) and (b)) and must-
- (i) have an FRL of not less than 60/60/60 when tested from the outside; or
 - (ii) be of masonry-veneer construction in which the external masonry veneer is not less than 90 mm thick; or

- (iii) be of masonry construction not less than 90 mm thick.

Explanatory Information:

See Figure 3.7.1.10 and 3.8.6.3 for internal *separating wall* construction under one common roof.

**Figure 3.7.1.2
MEASUREMENT OF DISTANCES (Plan view)**

Note: Setback distance is measured at right angles to the boundary.

Diagram a.

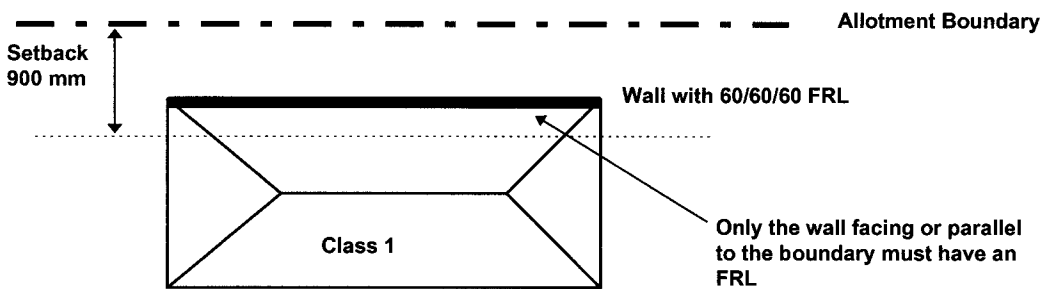
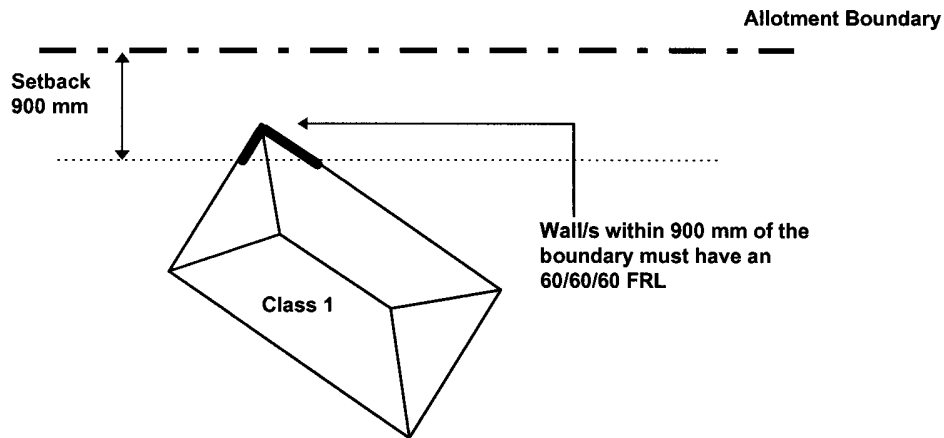

Diagram b.



- (b) Openings in *external walls required to be fire resisting* (referred to in 3.7.1.3 or 3.7.1.6) must be protected by-
 - (i) non-openable fire *windows* or other construction with an FRL of not less than - /60/ - ; or
 - (ii) *self-closing* solid core doors not less than 35 mm thick.

Amdt 11

- (c) Sub-floor vents, roof vents, weepholes and penetrations for pipes, conduits and the like need not comply with (b).
- (d) Concessions for non-habitable room windows

Despite the requirements in (b), in a non-habitable room, a window that faces the boundary of an adjoining allotment may be not less than 600 mm from that boundary or, where the window faces another building on the same allotment, not less than 1200 mm from that building provided that-

- (i) in a bathroom, laundry or toilet, the opening has an area of not more than 1.2 m²; or
- (ii) in a room other than referred to in (i), the opening has an area of not more than 0.54 m² and-
 - (A) the window is steel-framed, there are no opening sashes and it is glazed in wired glass; or
 - (B) the opening is enclosed with translucent hollow glass blocks.

Amdt 11

Figure 3.7.1.3(a)
ACCEPTABLE CONSTRUCTION OF EXTERNAL WALLS

Note: Wall to extend to the underside of non-combustible roof covering; or non-combustible eaves lining.

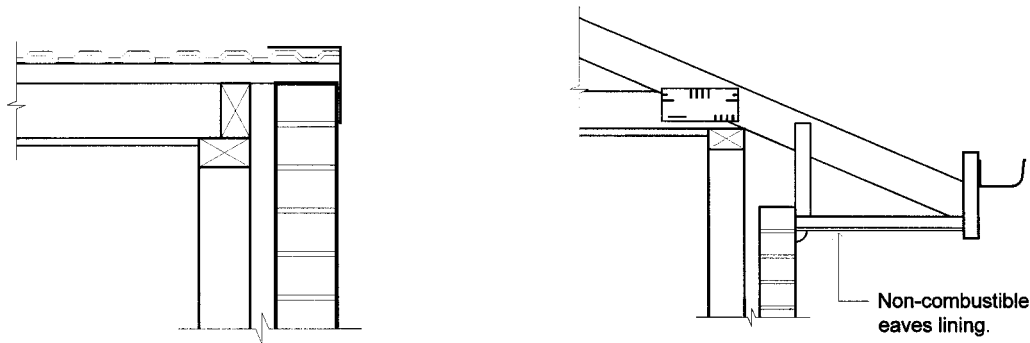
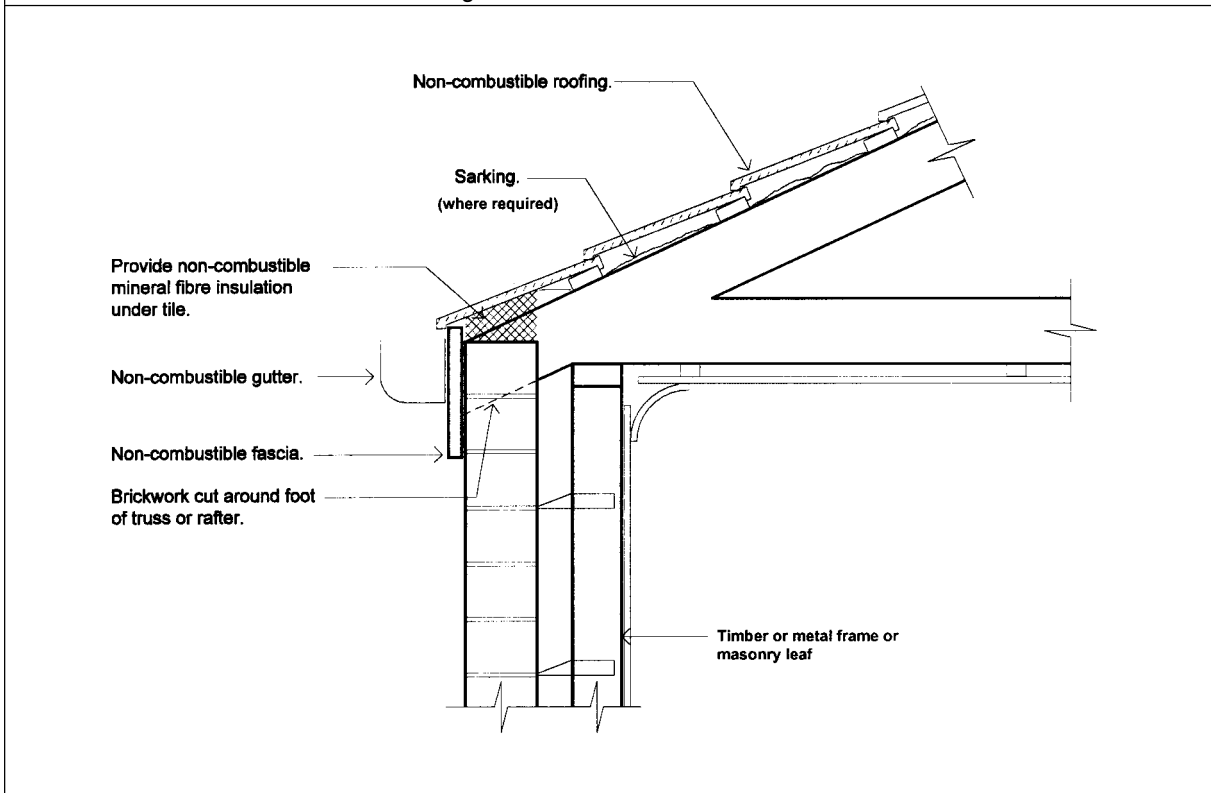

Figure
3.7.1.3(b)
Amdt No. 5

Figure 3.7.1.3(b)
ACCEPTABLE CONSTRUCTION OF EXTERNAL WALLS

Notes:

1. The *external wall* must extend to the underside of a *non-combustible* roof covering; or *non-combustible* eaves lining.
2. Where sarking is installed it must be located so that ponding of water is avoided between the fascia and the first roofing batten.



Amdt 11

3.7.1.6 Class 10a buildings

- (a) Where a Class 10a building is located between a Class 1 building and the allotment boundary, other than the boundary adjoining a road alignment or other public space, the Class 1 building must be protected by one of the following methods shown in Figure 3.7.1.4.
- (b) Where a Class 10a building is located between a Class 1 building to which it is appurtenant and another building on the same allotment, the Class 1 building must be protected by one of the methods shown in Figure 3.7.1.5.
- (c) Where two or more Class 10a buildings on the same allotment are appurtenant to different Class 1 buildings, the Class 10a buildings must be separated in accordance with one of the methods shown in Figure 3.7.1.6.

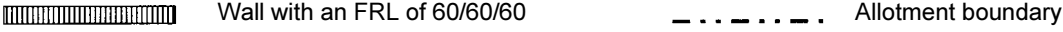
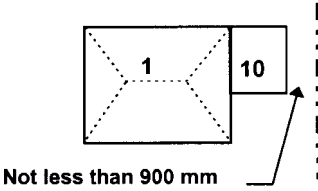
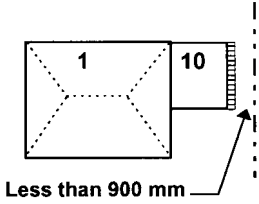
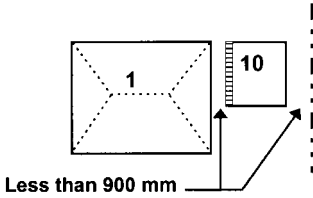
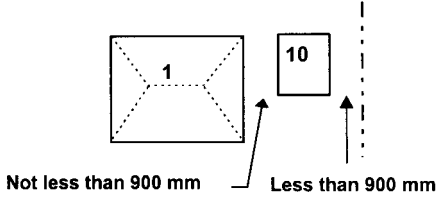
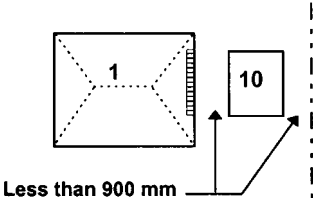
Figure 3.7.1.4 PROTECTION OF CLASS 1 BUILDINGS – CLASS 10a BETWEEN CLASS 1 AND THE ALLOTMENT BOUNDARY	
Legend: 	
a. 900 mm from allotment boundary	<p>The Class 10a building is not less than 900 mm from the allotment boundary, other than the boundary adjoining a road alignment or other public space.</p> 
b. External wall to Class 10a building with FRL	<p>An <i>external wall</i> of the Class 10a building which is less than 900 mm from an allotment boundary, other than the boundary adjoining a road alignment or other public space, complies with 3.7.1.5.</p> 
c. External wall to Class 10a building with FRL	<p>An <i>external wall</i> of the Class 10a building which is less than 900 mm from the Class 1 building complies with 3.7.1.5.</p> 
d. 900 mm separation between buildings	<p>The Class 1 building is not less than 900 mm from the Class 10a building.</p> 
e. Class 1 building with FRL to external wall	<p>An <i>external wall</i> of the Class 1 building which is less than 900 mm from the Class 10a building complies with 3.7.1.5.</p> 

Amdt 11

Figure 3.7.1.5
PROTECTION OF CLASS 1 BUILDINGS – CLASS 10a BETWEEN CLASS 1 AND OTHER BUILDINGS ON ALLOTMENT

Legend:



Wall with a FRL or 60/60/60



Other Class building on allotment

a. 1.8 m from other building on allotment

The Class 10a building is not less than 1.8 m from the other building.

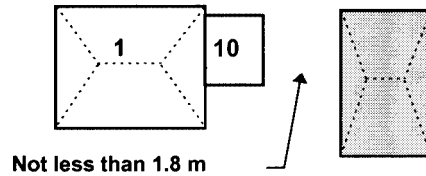

b. External wall to Class 10a building with FRL

An *external wall* of the Class 10a building which is less than 1.8 m from the other building complies with 3.7.1.5.

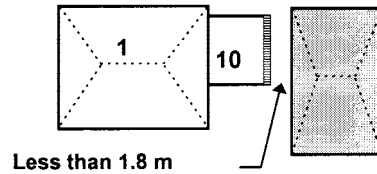

c. External wall to Class 10a building with FRL

An *external wall* of the Class 10a building which is less than 1.8 m from the Class 1 building complies with 3.7.1.5.

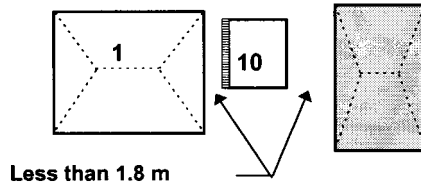

d. 1.8 m separation between Class 1 and 10a

The Class 1 building is not less than 1.8 m from the Class 10a building.

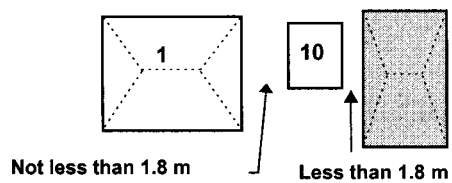

e. Class 1 building with FRL to external wall

An *external wall* of the Class 1 building which is less than 1.8 m from the Class 10a building complies with 3.7.1.5.

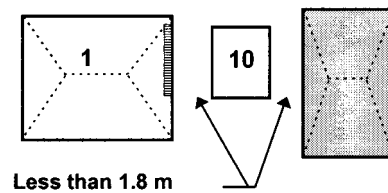

Figure 3.7.1.6
Amdt No. 7

**Figure 3.7.1.6
PROTECTION OF CLASS 1 BUILDINGS – SEPARATION OF CLASS 10a BUILDINGS ON AN ALLOTMENT**

Legend:  Wall with a FRL or 60/60/60

a. 1.8 m between Class 10a buildings

Each 10a must be separated from each other by a distance of not less than 1.8 m.

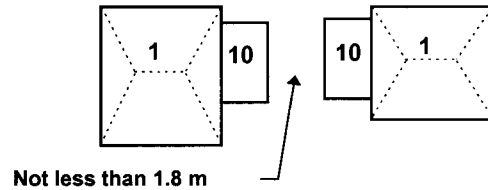

b. External wall to Class 10a building with FRL

Each 10a must be separated from each other by external walls complying with 3.7.1.5.

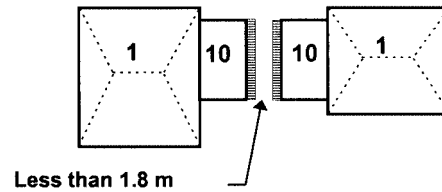

c. 900 mm separation between Class 10a and Class 1 buildings

Each 10a must be separated from each Class 1 building by a distance of not less than 900 mm.

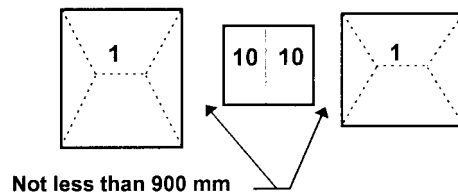

d. External wall to Class 10a buildings with FRL

Each 10a must be separated from each Class 1 building by external walls complying with 3.7.1.5.

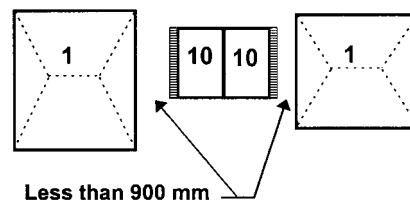

e. Class 10a buildings with FRL to separating wall

Each 10a must be separated by a wall complying with 3.7.1.8.

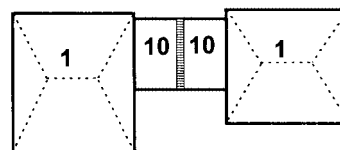

Amdt 11

- (d) A carport is exempt from (a), (b) and (c) if-
 - (i) it has two or more sides open and not less than one third of its perimeter open and, for the purposes of this clause, a side is considered to be open if the roof covering adjacent to that side is not less than 500 mm from another building or allotment boundary; and
 - (ii) it has a *non-combustible* roof covering and any ceiling lining and wall cladding, including gables, is also *non-combustible* (see Figure 3.7.1.7); and

Figure 3.7.1.7
IDENTIFYING AN OPEN CARPORT

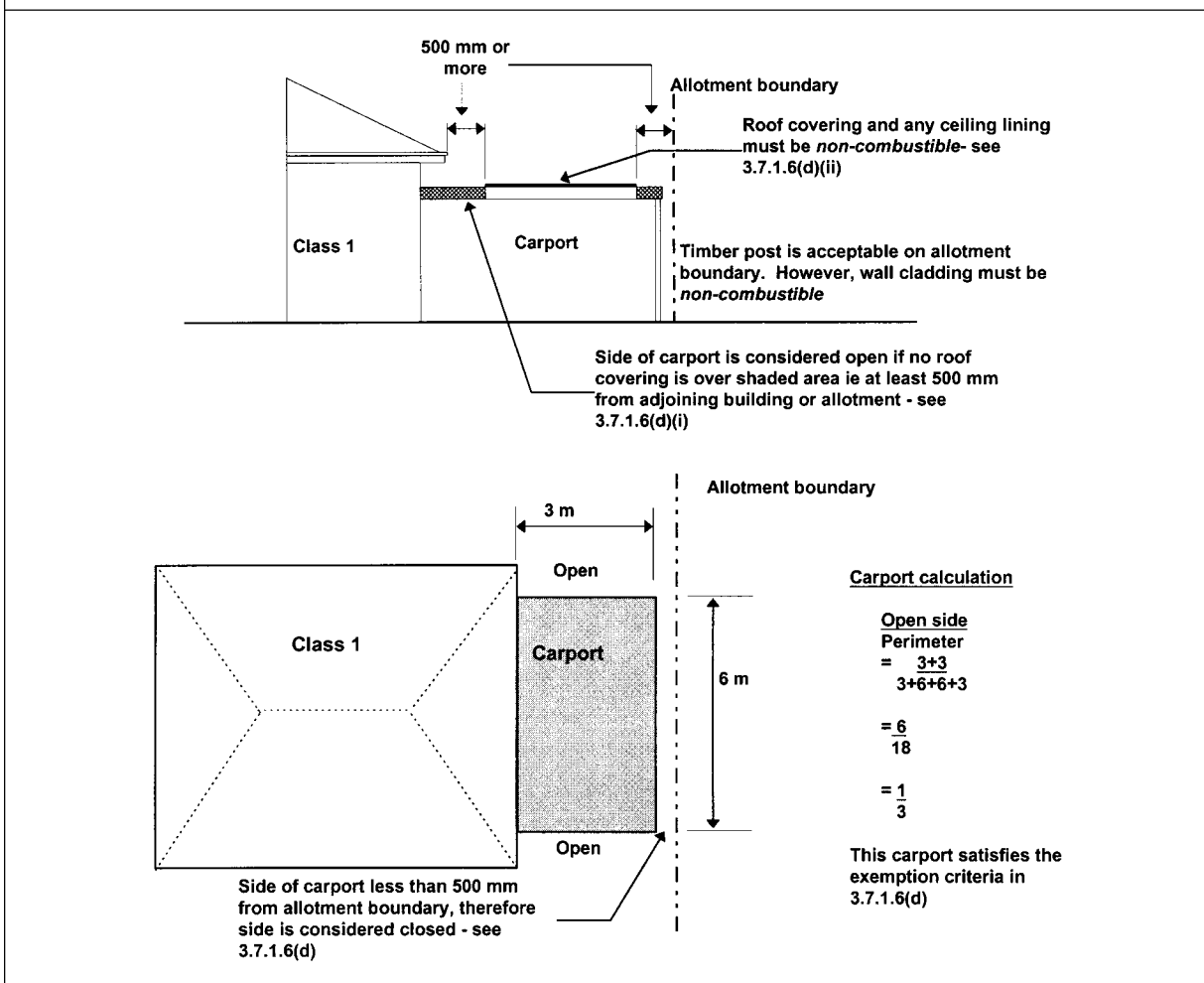

Amdt 11

- (iii) it does not provide direct vertical support to any part of the Class 1 building; and
- (iv) in the case where it has a common roof structure with the Class 1 building and the carport does not have a ceiling (see Figure 3.7.1.8), the opening between the top of the wall of the Class 1 building and the underside of the roof covering is infilled with-
 - (A) a *non-combustible* material; or
 - (B) construction clad with *non-combustible* material on the carport side.

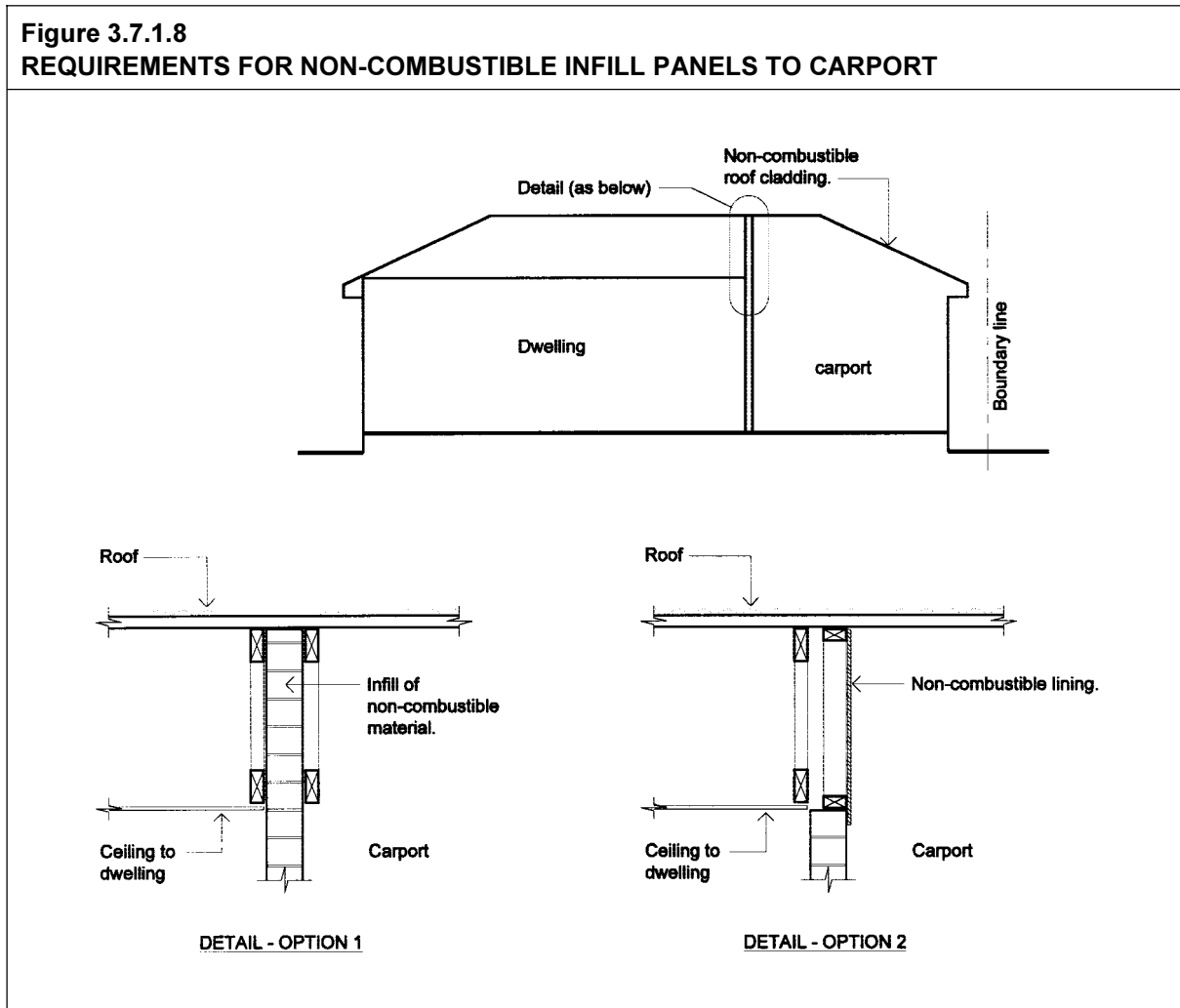

Amdt 11

- (e) Class 10a buildings must not significantly increase the risk of spread of fire between Class 2 to 9 buildings.

3.7.1.7 Allowable encroachments

3.7.1.7(a)
Amdt No. 8

- (a) An encroachment is any construction between the *external wall* of the building and the allotment boundary other than a boundary adjoining a road or other public space, or the *external walls* of two buildings on the same allotment and relates to any *external wall* of-
- (i) a Class 10a building required to comply with 3.7.1.5; or
 - (ii) a Class 1 building.
- (b) The encroachments allowed within 900 mm of an allotment boundary or within 1.8 m of another building on the same allotment are-
- (i) fascias, gutters, downpipes and the like; and
 - (ii) eaves with *non-combustible* roof cladding and *non-combustible* lining; and
 - (iii) flues, chimneys, pipes, domestic fuel tanks, cooling or heating appliances or other services; and
 - (iv) light fittings, electricity or gas meters, aerials or antennas; and
 - (v) pergolas or sun blinds; and
 - (vi) unroofed terraces, landings, steps and ramps, not more than 1 m in height.
- (c) Encroachments listed in (b)(i), if *combustible*, (b)(ii) and (b)(iii) must not be built within 450 mm of an allotment boundary nor be built within 900 mm of the *external wall* or associated encroachments of another building on the same allotment. (see Figure 3.7.1.9)

Figure 3.7.1.9
Amdt No. 3

Figure 3.7.1.9
ALLOWABLE ENCROACHMENTS FOR NON-COMBUSTIBLE CONSTRUCTION

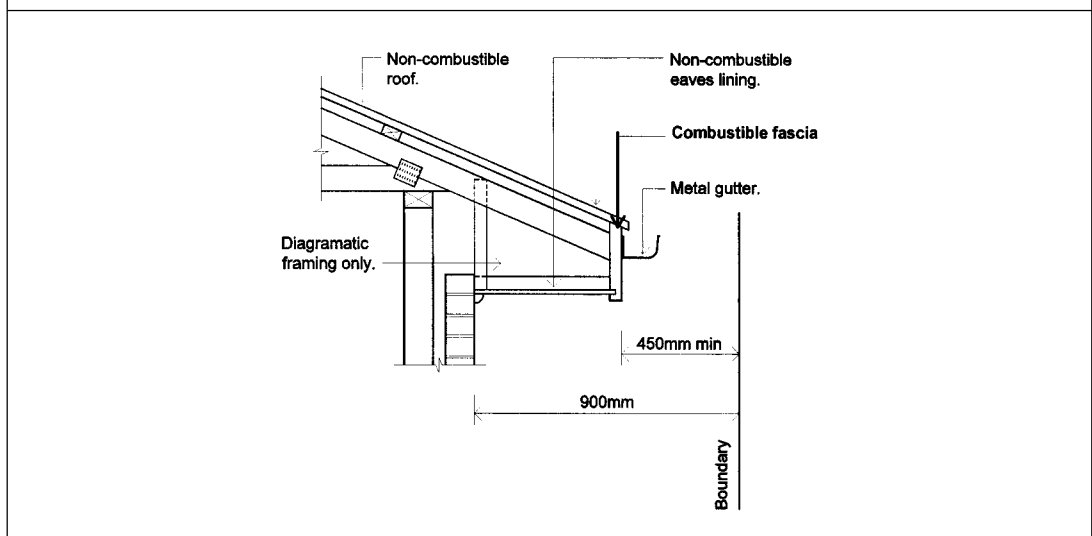

3.7.1.8 Separating walls

3.7.1.8
Amdt No. 11

- (a) A wall that separates Class 1 dwellings, or separates a Class 1 building from a Class 10a building which is not appurtenant to that Class 1 building must have an FRL of not less than 60/60/60 and-
- (i) commence at the footings or ground slab (see Figure 3.7.1.10); and
 - (ii) extend-
 - (A) if the building has a *non-combustible* roof covering, to the underside of the roof covering (see Figure 3.7.1.10 and Figure 3.7.1.11); or
 - (B) if the building has a *combustible* roof covering, to not less than 450 mm above the roof covering (see Figure 3.7.1.10).
- (b) A *separating wall* of *lightweight construction* must be tested in accordance with Specification C1.8 of the BCA Volume One.

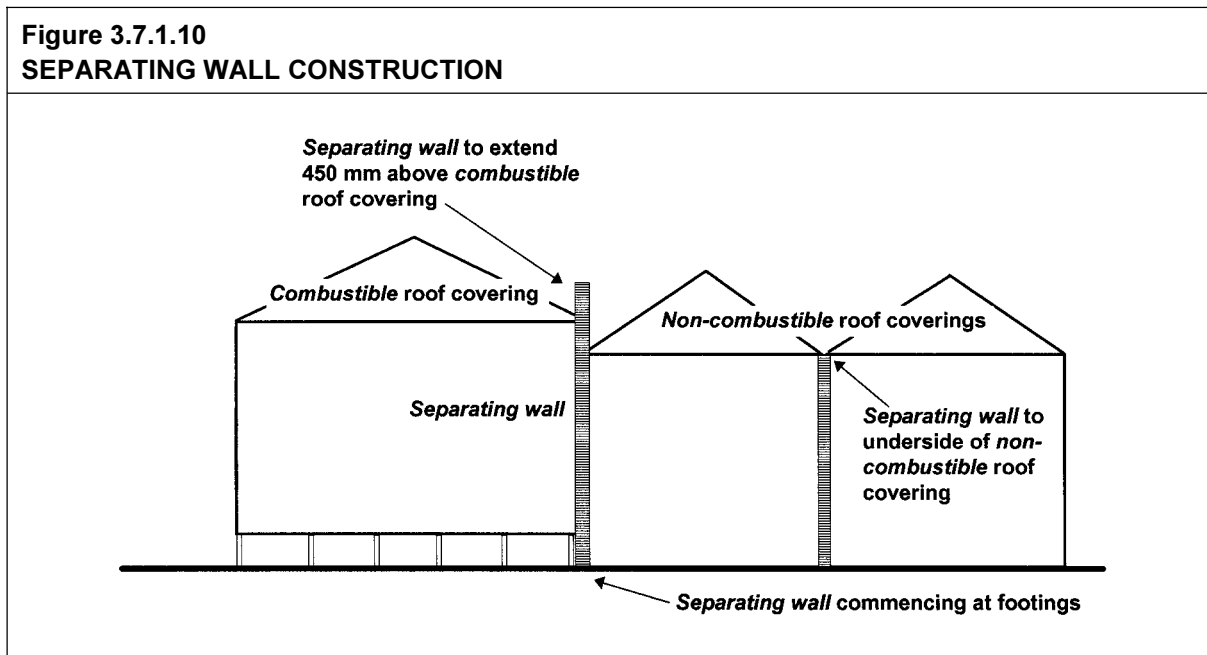

- (c) A *separating wall* complying with (a)(ii)(A)-
- (i) must not be crossed by timber or other *combustible* building elements except for roof battens with dimensions of 75x50 mm or less; and
 - (ii) must have any gap between the top of the wall and the underside of the roof covering packed with mineral fibre or other suitable *fire-resisting* material.

- (d) Where a building has a masonry veneer *external wall*, any gap between the *separating wall* and the external masonry veneer must be-
- (i) not more than 50 mm; and
 - (ii) packed with a mineral fibre or other suitable *fire-resisting* material with the packing arranged to maintain any weatherproofing requirements of Part 3.3.4.

3.7.1.8(e)
Amdt No. 7

- (e) Eaves, verandahs and similar spaces that are open to the roof space and are common to more than one Class 1 dwelling must be separated by a *non-combustible* vertical lining (see Figure 3.7.1.11 Diagram b).

3.7.1.9 Fire hazard properties

3.7.1.9
Amdt No. 5

The fire hazard properties of materials used in a Class 1 building, including common floor or ceiling spaces with a Class 10 building, must comply with the following:

- (a) *Sarking-type materials* used in the roof must have a *flammability index* not greater than 5.
- (b) Flexible ductwork used for the transfer of products initiating from a heat source that contains a flame must comply with the fire hazard properties set out in AS 4254.

3.7.1.10 Roof lights

Combustible roof lights, skylights or the like installed in a roof or part of a roof *required* to have a *non-combustible* covering must-

- (a) have an aggregate area not more than 20% of the roof or part of the roof; and
- (b) be not less than-
 - (i) 900 mm from-
 - (A) the allotment boundary other than the boundary adjoining a road alignment or other public space; and
 - (B) the vertical projection of a *separating wall* extending to the underside of the roof covering; and
 - (ii) 1.8 m from any roof light or the like in another building on the allotment other than an appurtenant building or a detached part of the same building.

(See Figure 3.7.1.12)

Amdt 11

Fig 3.7.1.11
Amdt No. 7

Figure 3.7.1.11
SEPARATING WALL CONSTRUCTION – UNDERSIDE OF NON-COMBUSTIBLE ROOF CLADDING

Diagram a.

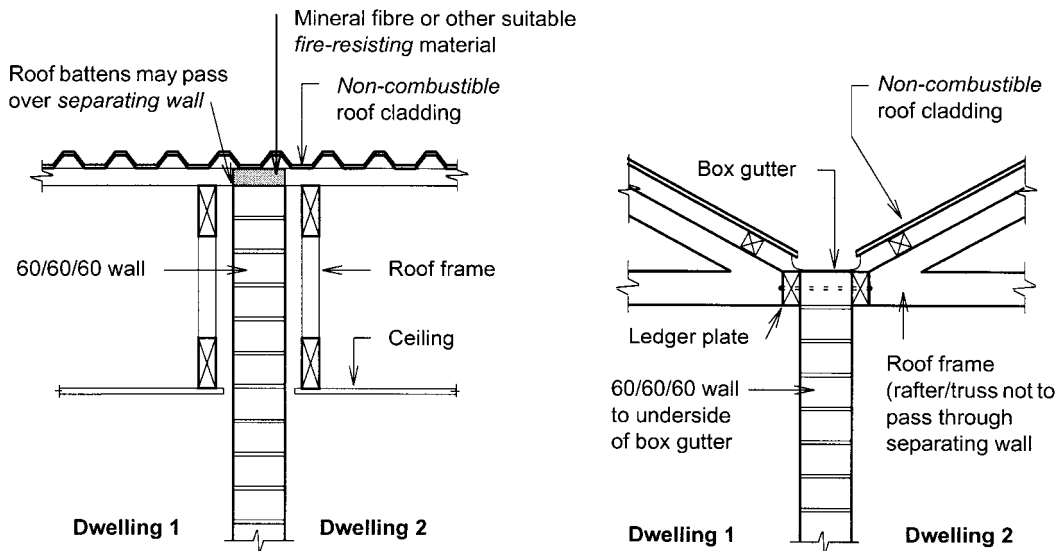
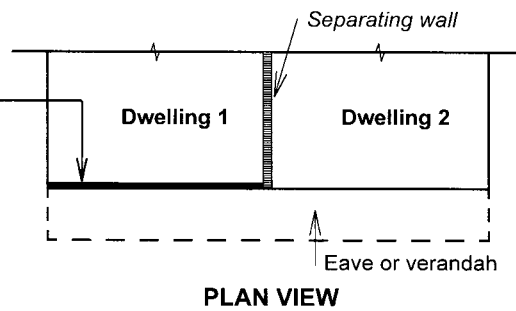
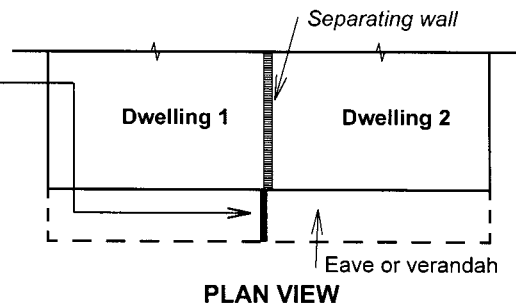

Diagram b.

OPTION 1 Non-combustible vertical lining installed between roof space of one Class 1 and the common eaves or verandah space
 Elements crossing the non-combustible vertical lining must comply with Clause 3.7.1.8 (c)(i)



OPTION 2 Non-combustible vertical lining installed in common eaves or verandah space
 Elements crossing the non-combustible vertical lining must comply with Clause 3.7.1.8 (c)(i)



Note: The Non-combustible vertical lining need only be installed on one side of a rafter, truss or supporting framework, provided that it forms a continuous barrier with the separating wall

Amdt 11

Figure 3.7.1.12
LOCATION OF COMBUSTIBLE ROOF LIGHTS

Note: Roof lights depicted in Figure 3.7.1.12 are *combustible*.

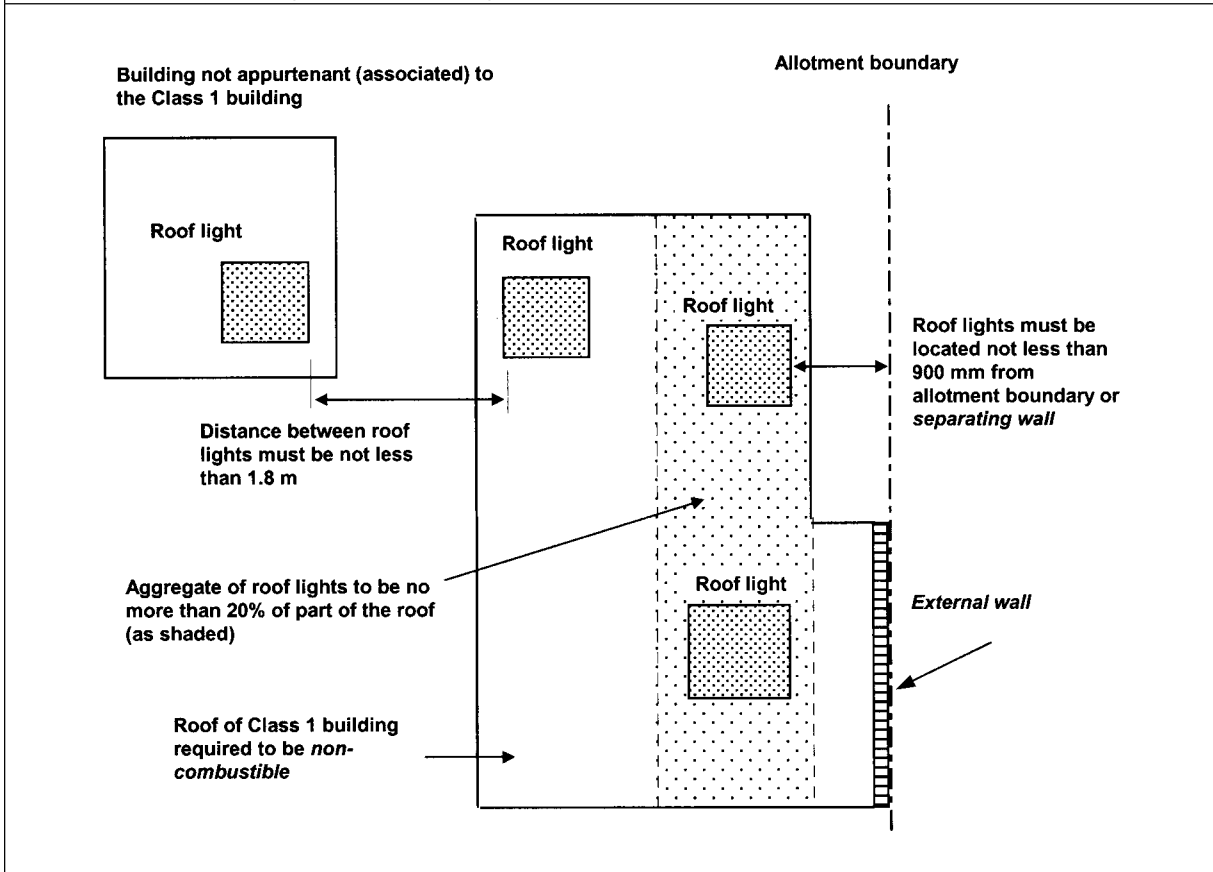

Amdt 11

PART 3.7.2 SMOKE ALARMS

Appropriate Performance Requirements

Where an alternative smoke alarm system is proposed to that described in Part 3.7.2, that proposal must comply with *Performance Requirement* P2.3.2 in Section 2.

Acceptable construction practice

3.7.2.1 Application

Compliance with this Part satisfies *Performance Requirement* P2.3.2 for smoke alarms.

3.7.2.2 Requirements for smoke alarms

3.7.2.2
Amdt No. 3

- (a) Smoke alarms must be installed in-
 - (i) Class 1a buildings in accordance with 3.7.2.3; and
 - (ii) Class 1b buildings in accordance with 3.7.2.4 and 3.7.2.5.
- (b) Smoke alarms must comply with AS 3786.
- (c) Smoke alarms must be connected to the consumer mains power where consumer power is supplied to the building.

3.7.2.3 Location - Class 1a buildings

Smoke alarms must be installed in a Class 1a building on or near the ceiling in-

- (a) any storey containing bedrooms-
 - (i) between each part of the dwelling containing bedrooms and the remainder of the dwelling; and
 - (ii) where bedrooms are served by a hallway, in that hallway, and
 - (b) any other storey not containing bedrooms.
- (see Figure 3.7.2.1, Diagram a and Figure 3.7.2.2)

3.7.2.4 Location - Class 1b buildings

3.7.2.4
Amdt No. 3

In a Class 1b building, smoke alarms must be installed on or near the ceiling-

- (a) in every bedroom; and
 - (b) in every corridor or hallway associated with a bedroom, or if there is no corridor or hallway, in an area between the bedrooms and the remainder of the building; and
 - (c) on each other storey.
- (see Figure 3.7.2.1, Diagram b and Figure 3.7.2.2)

3.7.2.5 Lighting to assist evacuation- Class 1b buildings

3.7.2.5
Amdt No. 3

In a Class 1b building, a system of lighting must be installed to assist evacuation of occupants in the event of a fire, and-

- (a) be activated by the smoke alarm *required* by 3.7.2.4(b); and
- (b) consist of-
 - (i) a light incorporated within the smoke alarm; or
 - (ii) the lighting located in the corridor, hallway or area served by the smoke alarm.

Explanatory information:

The lighting required by 3.7.2.5 may consist of the artificial lighting which may already be installed in a corridor, hallway or area, provided that lighting is activated by the smoke alarm.

Figure
3.7.2.1
Amdt No. 3

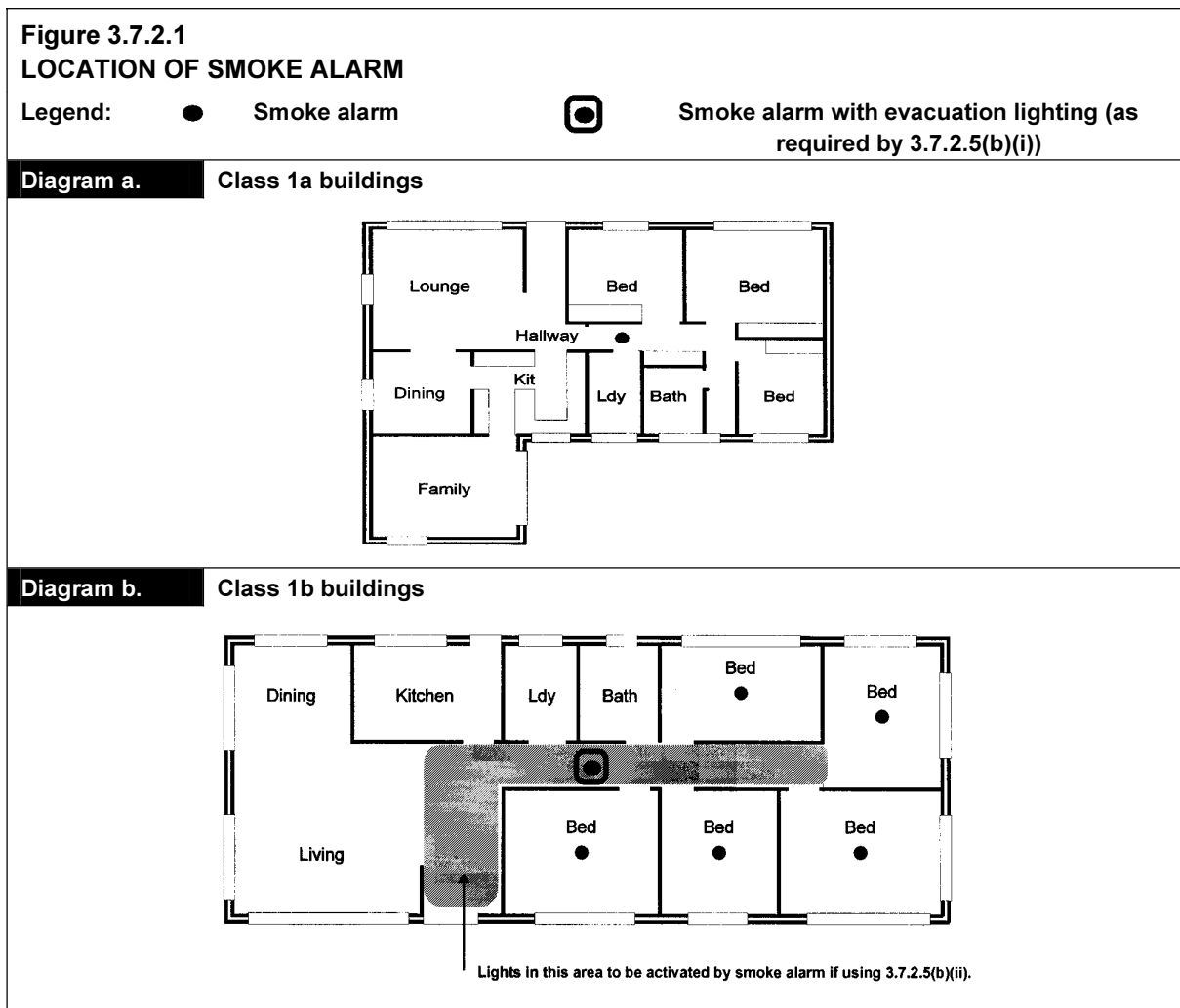

Amdt 11

Figure 3.7.2.2
LOCATION OF SMOKE ALARMS ON DIFFERENT STOREYS

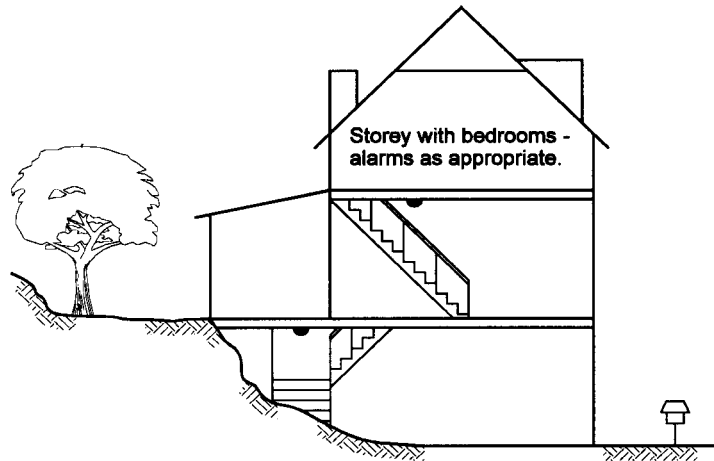

(d) Smoke alarms installed on each storey not containing bedrooms - located in the area of the stairway.

Amdt 11

Explanatory information:

1. HOW DOES A SMOKE ALARM WORK ?

There are two types of smoke alarms.

1.1 Photoelectric:

This type of smoke alarm uses a light source and photocell. As the smoke enters the detection chamber it interferes with the light beam which in turn causes the alarm to sound.

1.2 Ionisation:

A small amount of radioactive material is used to create an electrical current which travels through ionised air. When smoke enters the detection chamber it impedes the flow of current and causes the alarm to sound.

2. LOCATION OF SMOKE ALARMS

When deciding on the position of smoke alarms it is important to remember that they are intended to detect smoke before it reaches the sleeping occupants of a building.

The ensuing alarm is designed to wake the occupants and give them time to evacuate the building.

2.1 Added flexibility when considering detector location

As mentioned earlier, the introduction of the *Performance Requirement* gives the *appropriate authority* flexibility when considering the location of smoke alarms.

For instance, in Class 1a buildings if the *Deemed-to-Satisfy Provision* states that the smoke alarm should be located in the hallway, and there is a bathroom adjacent this location (that will potentially cause nuisance alarms) the *appropriate authority* could accept the alarm being installed in the bedroom as a suitable option using the performance clause.

Explanatory information (cont):

This approach should also be adopted when considering sleep-outs or similar type residential buildings that are not connected to the remainder of the building by a hallway or other enclosed structure. In these situations the alarm could be located in the room itself.

2.2
Amdt No. 2

2.2 Protection of sleeping areas in Class 1a buildings

The deemed-to-satisfy provisions require that a smoke alarm be located “between each area containing bedrooms and the remainder of the dwelling”.

In some dwellings the bedrooms are located in a common area and connected by a hallway. In this instance the alarm should be located as shown in Figure 3.7.2.1, diagram a.

2.3
AmdtNo. 2

2.3 Location of the smoke alarm on other storeys

A smoke alarm is also required on each other storey that is not already provided with a smoke alarm. It should be noted that smoke alarms are required to be installed in other storeys even if those storeys consist of only carparking, bathrooms, laundries and the like. “Storey” in this context differs from the definition contained in BCA96 Volume One which excludes such spaces from being considered as storeys

The favoured location for this alarm will be in the path of travel people will most likely take to evacuate the building. This will ensure an alarm will be raised before smoke makes the common exit path impassable.

eg If the bedrooms are on the first floor, then an alarm should be positioned near the area of the inter connecting stair at ground level.

If the other storey is not connected to the remainder of the building (for instance a ground floor garage) then the alarm should be centrally located in the lower area. However, it may be reasonable, using a performance approach, not to install smoke alarms where the storey is predominantly open, such as the basement level of a highset house on stumps that is used for carparking or laundry purposes.

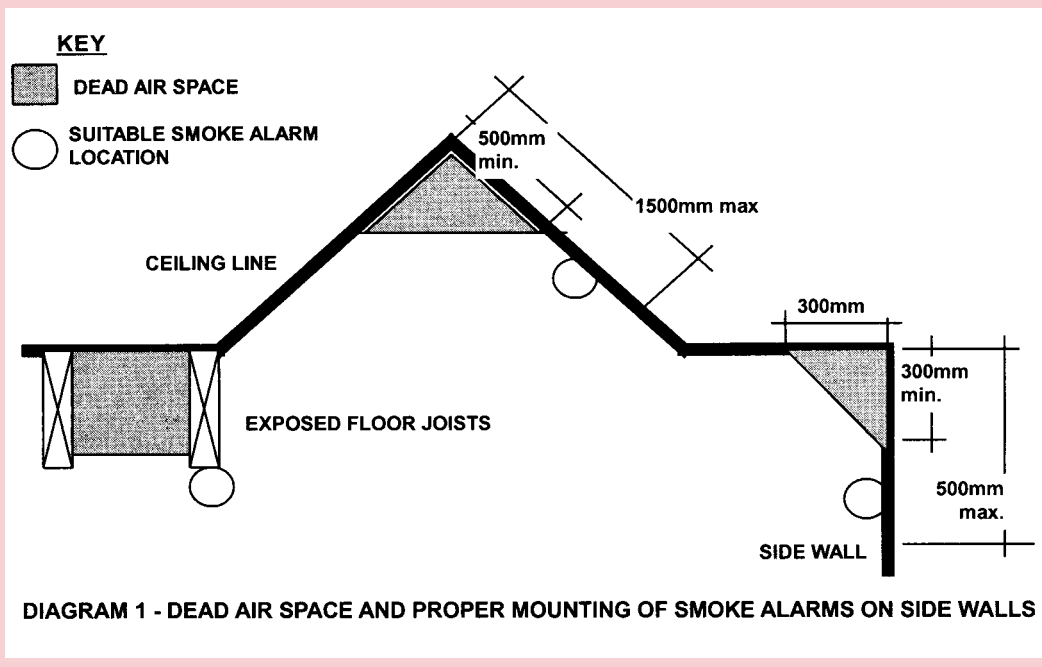

Amdt 11

Explanatory information (cont):**2.4 Installation of smoke alarms**

Smoke alarms should be installed on or near the ceiling with special care being taken to avoid dead air spaces.

A dead air space is an area in which trapped hot air will prevent smoke from reaching the alarm. This space generally occurs at the apex of cathedral ceilings, the corner junction of walls and ceilings, between exposed floor joists etc (See Diagram 1).

If it is impractical to mount the smoke alarm on the ceiling then it may be located on the wall. The recommended position is between 300 mm and 500 mm off the ceiling (See Diagram 1).

The distance from the apex of a cathedral ceiling to the top of the alarm should be between 500 mm and 1500 mm.

3. NUISANCE ALARMS

Smoke alarms are extremely sensitive and may detect smoke and moisture created by common household activities (such as burnt toast or steam from a bathroom).

Accordingly, to reduce the likelihood of nuisance alarms, the smoke alarm should not be located near cooking appliances and bathrooms. However, if it is necessary to locate alarms in these positions, an ionisation type alarm is more suitable near bathrooms, while a photoelectric alarm may be used near cooking appliances.

4. INTERCONNECTION OF SMOKE ALARMS

Some types of alarm are capable of interconnection to the other alarms so that if one alarm sounds then the other alarms are also activated adding an enhanced level of safety. There is no requirement in the BCA that smoke alarms be interconnected.

PART 3.7.3 HEATING APPLIANCES

Appropriate Performance Requirements:

Where an alternative heating appliance is proposed to that described in Part 3.7.3, that proposal must comply with *Performance Requirement P2.3.3* in Section 2.

A. Acceptable construction manuals

3.7.3.0 *Performance Requirement P2.3.3* is satisfied for a heating appliance if it is installed in accordance with one of the following manuals:

Amdt No. 11

- (a) Domestic oil-fired appliances are installed in accordance with AS 1691.
- (b) Domestic solid-fuel burning appliances are installed in accordance with AS/NZS 2918.
- (c) Boilers and pressure vessels are installed in accordance with AS/NZS 1200.

B. Acceptable construction practice

3.7.3.1 Application

Compliance with this Part satisfies *Performance Requirement P2.3.3* for heating appliances.

3.7.3.2 Open fireplace construction

An open fireplace must be constructed as follows (also see Figure 3.7.3.1):

- (a) All masonry must be constructed in accordance with Part 3.3.
- (b) The front hearth must be constructed of stone, concrete, masonry or similar material so that-
 - (i) it extends not less than 300 mm beyond the front of the fireplace opening and not less than 150 mm beyond each side of that opening; and
 - (ii) its upper surface does not slope away from the back hearth.
- (c) The base of the back hearth must be constructed of stone, concrete, masonry or similar material and any *combustible* flooring or framing members must be situated not less than 150 mm from its upper surface.
- (d) The fireplace rear and side walls up to a height of 300 mm above the underside of the arch or lintel-
 - (i) must be constructed in 2 separate leaves of solid masonry with an overall thickness not less than 180 mm thick, excluding any *cavity*; and
 - (ii) must not consist of concrete block masonry in the construction of the inner leaf; and

- (iii) must be constructed of masonry units with a net volume, excluding cored and similar holes, not less than 75% of their gross volume, measured on the overall rectangular shape of the units, and with an actual thickness of not less than 100 mm.
- (e) The fireplace must be constructed on footings complying with 3.2.5.5.

**Figure 3.7.3.1
FIRE PLACE CLEARANCE FROM COMBUSTIBLE MATERIALS**

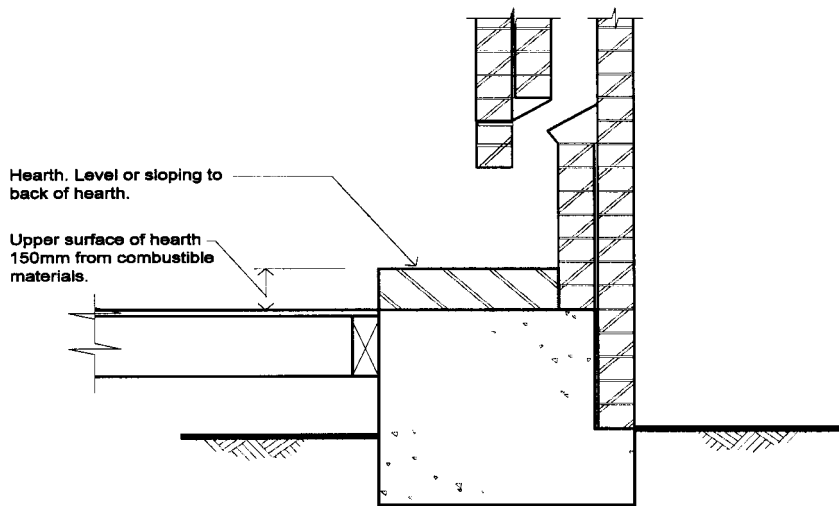
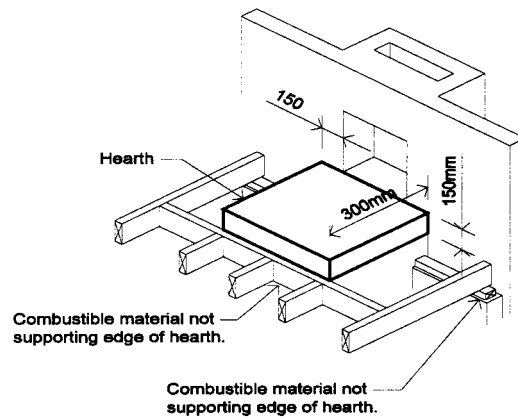

Amdt 11

3.7.3.3 Chimney construction

The construction of a chimney must comply with Part 3.3 and the following:

- (a) The walls of the chimney above the level referred to in 3.7.3.2(d) must be lined internally to a thickness of not less than 10 mm with composition mortar parging.
- (b) The chimney or flue must terminate not less than 300 mm above the highest part of the building within a horizontal distance of 3.6 m of the chimney or flue (see Figure 3.7.3.2).

3.7.3.3(b)
Amdt No. 3

Fig 3.7.3.2
Amdt No. 3

Amdt 11

Figure 3.7.3.2
SECTION SHOWING HEIGHT AND POSITION OF CHIMNEY

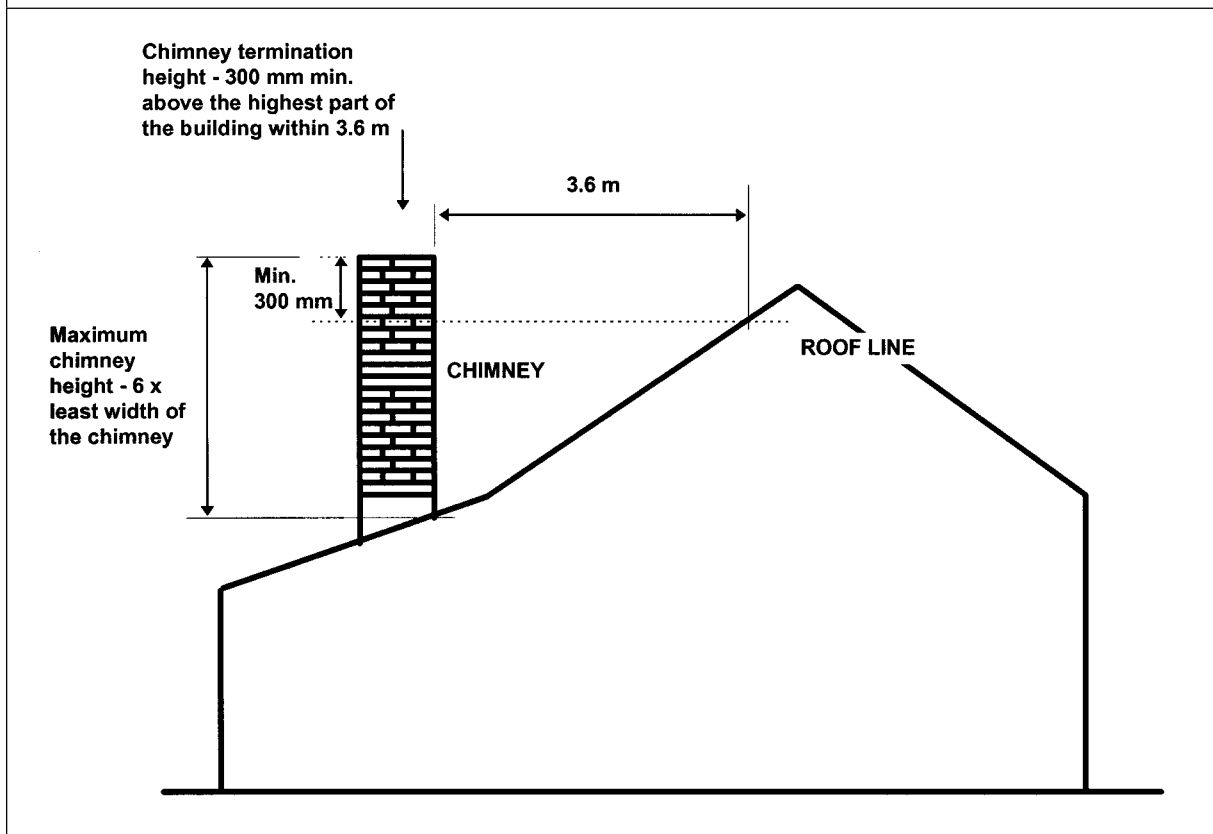

3.7.3.4 Installation of insert fireplaces and flues

3.7.3.4
Amdt No. 11

An insert fireplace and flue must comply with the following:

- (a) The insert fireplace must be tested and passed the tests required by AS/NZS 2918.
- (b) The insert fireplace must be fitted into a masonry fireplace (including chimney) constructed in accordance with Part 3.3.

- (c) The flue must be-
 - (i) double skin and have been tested and pass the tests required by AS/NZS 2918; or
 - (ii) cast iron, cellulose fibre reinforced cement not less than 9.5 mm thick, galvanised steel not less than 1.2 mm thick or such other material of at least equivalent strength and durability, installed in accordance with Section 6 of AS 1691, as though it is a flue connected to an oil heating appliance.

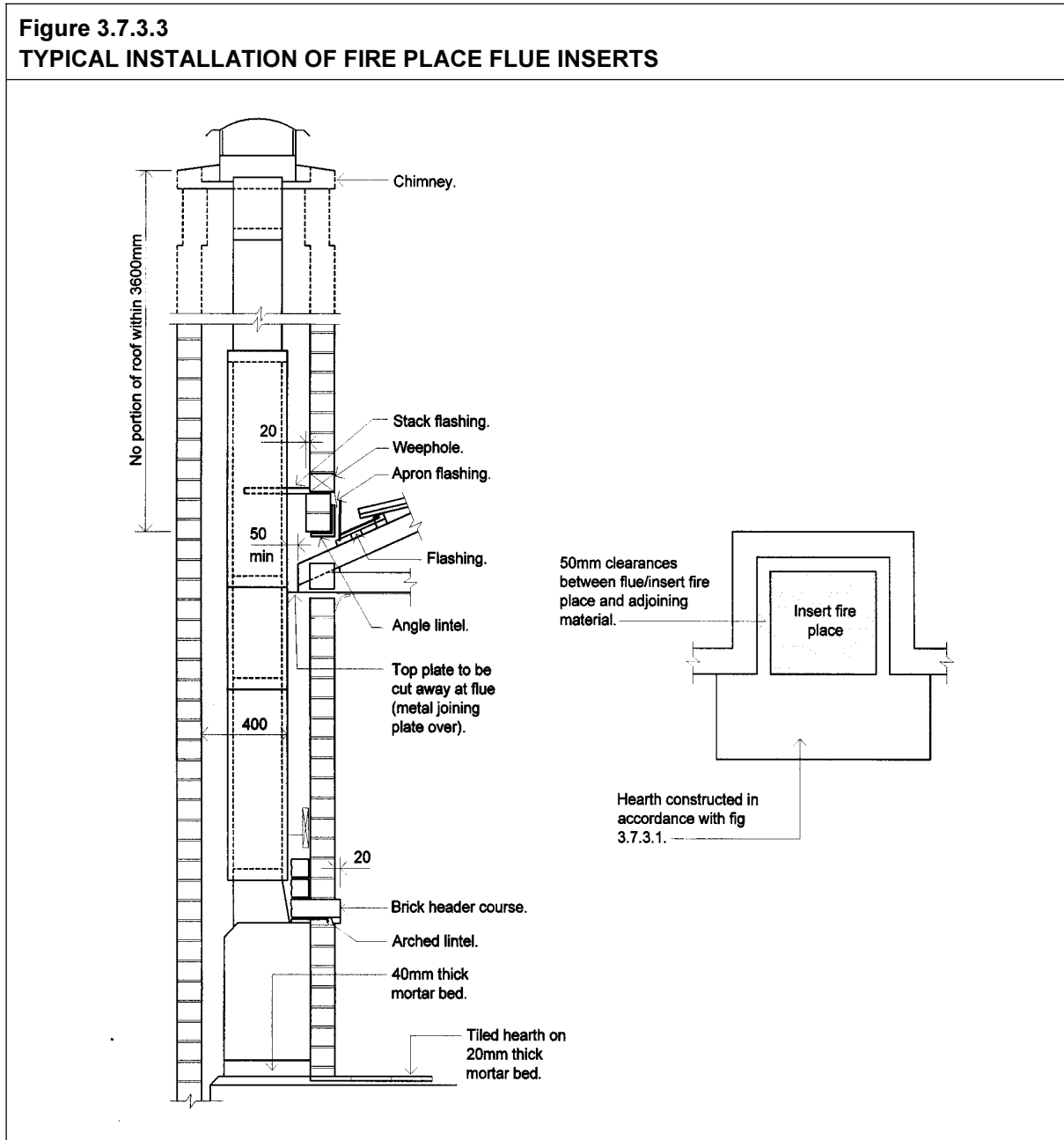

- (d) There must be a clearance of 50 mm between the outer flue and adjacent materials.
- (e) The flue must terminate in accordance with Figure 3.7.3.2.
- (f) The hearth must be constructed in accordance with 3.7.3.2(b), (c) and (e).

3.7.3.5 Installation of free standing heating appliances

Amdt No. 11

The installation of a free standing heating appliance must comply with the following:

- (a) The appliance must-
 - (i) be installed with safety clearances determined by testing in accordance with AS/NZS 2918; or
 - (ii) be located not less than 1.2 m from adjoining walls (other than a masonry wall); or
 - (iii) have a heat shield between the adjoining wall (other than a masonry wall) and the heating appliance in accordance with Figure 3.7.3.4.
- (b) Where a heat shield is used, it must be installed in accordance with Figure 3.7.3.4 and it must be not less than 90 mm thick masonry constructed in accordance with Part 3.3.
- (c) The heating appliance must be installed on a hearth-
 - (i) complying with 3.7.3.2(b) and (c), except that the hearth must extend 400 mm from the appliance in accordance with Figure 3.7.3.4; or
 - (ii) where a heat shield is installed, in accordance with Figure 3.7.3.4.
- (d) The flue must-
 - (i) have been tested and passed the tests required by AS/NZS 2918; and
 - (ii) be installed in accordance with Figure 3.7.3.5; and
 - (iii) terminate in accordance with Figure 3.7.3.2.
- (e) Flue types or installation of flues in areas not specifically covered by Figures 3.7.3.4 and 3.7.3.5 must be installed in accordance with AS/NZS 2918.

Amdt 11

Figure 3.7.3.4
ACCEPTABLE LOCATION OF FREE STANDING HEATING APPLIANCES

Diagram a. ELEVATION

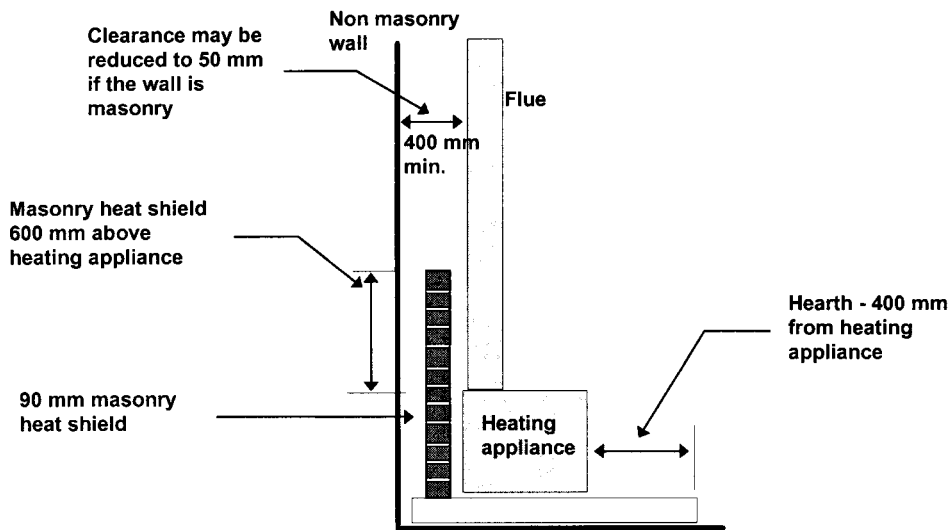

Diagram b. PLAN VIEW

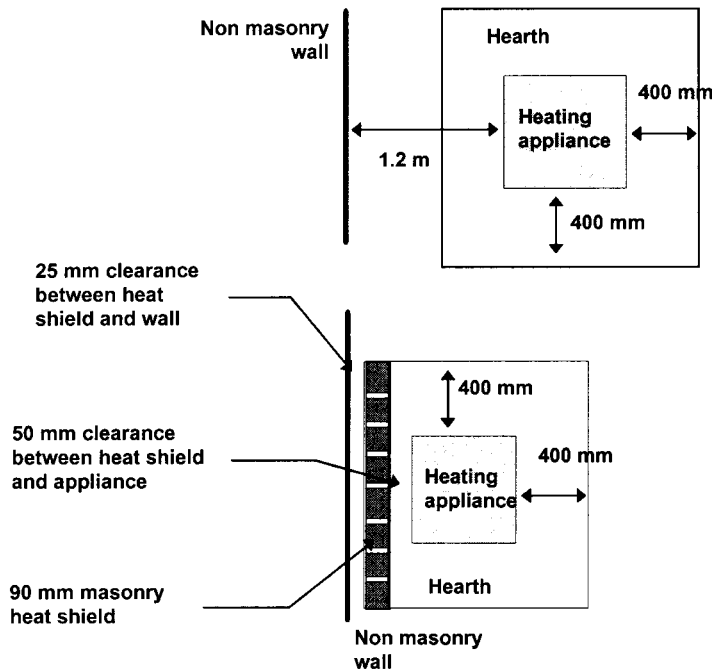
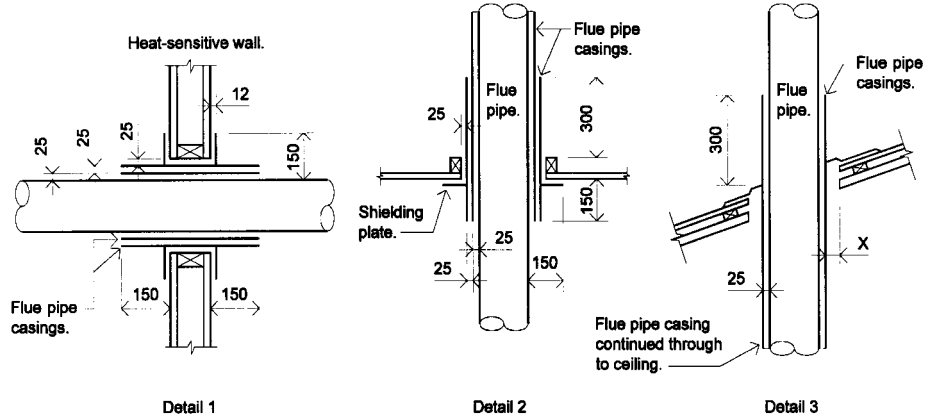
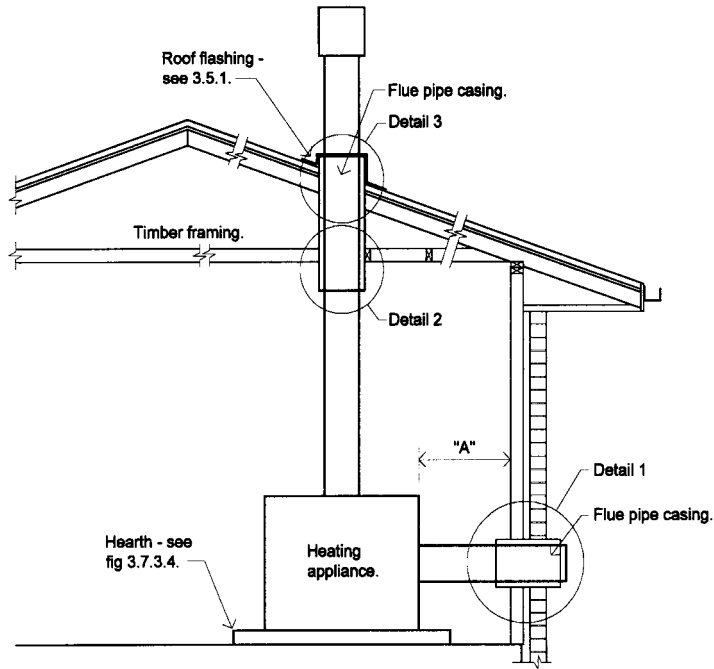

Fig 3.7.3.5
Amdt No. 11

Figure 3.7.3.5
ACCEPTABLE FLUE INSTALLATION DETAILS

Note: Flue pipe size – 150 mm maximum (for other sizes see AS/NZS 2918)



Amdt 11

PART 3.7.4 BUSHFIRE AREAS

Appropriate Performance Requirements

Where an alternative bushfire protection design is proposed to that described in Part 3.7.4, that proposal must comply with *Performance Requirement P2.3.4* in Section 2.

A. Acceptable construction manuals

3.7.4.0 *Performance Requirement P2.3.4* is satisfied for a Class 1 building located in a *designated bushfire prone area* if it is constructed in accordance with AS 3959 - Construction of buildings in bushfire prone areas.

3.7.4.0
Amdt No. 6

SA var.
Amdt No. 9

STATE AND TERRITORY VARIATIONS

3.7.4.0 is replaced by the following clause in South Australia:

Performance Requirement P2.3.4 is satisfied for a Class 1 building located in a *designated bushfire prone area* as defined under relevant State and Territory legislation, if it is constructed in accordance with AS 3959 and the following-

Additional bushfire protection shall be provided in medium, high and extreme attack categories (as determined from AS 3959) as follows:

- (a) A framed floor, the underside of which is greater than 600 mm above ground level shall have the sub-floor space completely protected by-
 - (i) a wall complying with AS 3959; or
 - (ii) a *non-combustible* sheet material; or
 - (iii) a vertical *non-combustible* sheet material that extends around the perimeter of the floor from the underside of the lowest framing member to ground level; and
 - (iv) if fibre-reinforced sheets are used as a *non-combustible* sheet material they must have a minimum thickness of 6 mm.
- (b) Wall cladding of *non-combustible* material or fire-retardant timber shall be provided within 400 mm of finished ground level, paving level or any balcony or deck with solid flooring.
- (c) Penetrations through the roof cladding for vent pipes and the like shall be sealed with a *non-combustible* collar or fire-retardant sealant.
- (d) Where a garage, carport, verandah or similar structure is attached to or shares a common roof space with a building *required* to comply with AS 3959, it must also comply with AS 3959.

Amdt 11

B. Acceptable construction practice
--

3.7.4.1 Application

3.7.4.1
Amdt No. 9

Compliance with this Part for Class 1 buildings constructed in a *designated bushfire prone area* satisfies *Performance Requirement P2.3.4*.

SA var.
Amdt No. 9

STATE AND TERRITORY VARIATIONS**3.7.4.1 is replaced by the following clause in South Australia:**

Compliance with this Part, and the following, for Class 1 buildings constructed in a *designated bushfire prone area* satisfies *Performance Requirement P2.3.4*:

Additional bushfire protection shall be provided in medium, high and extreme attack categories (as determined from AS 3959) as follows:

- (a) A framed floor, the underside of which is greater than 600 mm above ground level shall have the sub-floor space completely protected by-
 - (i) a wall complying with AS 3959; or
 - (ii) a *non-combustible* sheet material; or
 - (iii) a vertical *non-combustible* sheet material that extends around the perimeter of the floor from the underside of the lowest framing member to ground level; and
 - (iv) if fibre-reinforced sheets are used as a *non-combustible* sheet material they must have a minimum thickness of 6 mm.
- (b) Wall cladding of *non-combustible* material or fire-retardant timber shall be provided within 400 mm of finished ground level, paving level or any balcony or deck with solid flooring.
- (c) Penetrations through the roof cladding for vent pipes and the like shall be sealed with a *non-combustible* collar or fire-retardant sealant.
- (d) Where a garage, carport, verandah or similar structure is attached to or shares a common roof space with a building *required* to comply with AS 3959, it must also comply with AS 3959.

3.7.4.2 Categories of bushfire attack

3.7.4.2
Amdt No. 7

The category of bushfire attack for a *site* must be determined in accordance with AS 3959.

Expl. Info
Amdt No. 9

Explanatory information:

AS 3959 contains a methodology for assessment of the category of bushfire attack for a *site*. The categories are determined by considering the predominant vegetation type, the distance between the *site* and the predominant vegetation, and the average slope of the land between the *site* and the predominant vegetation. The categories of bushfire attack are low, medium, high and extreme.

For the category of low bushfire attack, the degree of bushfire attack is considered insufficient to warrant specific construction requirements.

3.7.4.3 Construction requirements

3.7.4.3
Amdt No. 10

- (a) A Class 1 building must be constructed using the acceptable methods listed in Table 3.7.4.1 for the category of bushfire attack for the *site*.
- (b) For the purposes of Part 3.7.4, fire-retardant-treated timber is timber that has been tested to AS/NZS 3837 and meets the following parameters after having been subjected to the regime of ASTM D2898 Method B:
 - (i) Ignition does not occur when the material is exposed to an irradiance level of 10 kW/m².
 - (ii) The maximum heat release rate is not greater than 100 kW/m² and the average heat release rate for 10 minutes following ignition is not greater than 60 kW/m² when the material is exposed to an irradiance level of 25 kW/m².
- (c) Where the timber is protected from the weather as described in Appendix C of AS 1684.2 and AS 1684.3, the timber need not be subjected to the regime of ASTM D2898 Method B before being tested to AS/NZS 3837.

Expl. Info
Amdt No. 11

Explanatory information:

External timbers are regarded as protected if they are covered by a roof (or similar structure) at 30° or greater to the vertical (see Figure 3.7.4.5) and they are well detailed and maintained (ie painted or stained and kept well ventilated).

Some timbers used in building construction may be capable of meeting the parameters identified in 3.7.4.3(b) without having to be subjected to fire retardant treatment.

Amdt 11

Table
3.7.4.1
Amdt No. 10

Table 3.7.4.1 CONSTRUCTION FOR MEDIUM, HIGH AND EXTREME CATEGORIES OF BUSHFIRE ATTACK	
FLOORING SYSTEMS	
1. Medium bushfire attack category	
(a)	Concrete slab on ground.
(b)	Suspended concrete floor.
(c)	Framed floor with all joists and/or bearers not less than 600 mm above finished ground level.
(d)	Framed floor where any joist and/or bearer is less than 600 mm above finished ground level, where- <ul style="list-style-type: none"> (i) any timber bearers, joists or flooring are of fire-retardant-treated timber; or (ii) the sub-floor space is fully enclosed with a wall complying with the requirements of this table for an <i>external wall</i>; or (iii) the sub-floor space is fully enclosed with <i>non-combustible</i> sheet material that extends not less than 400 mm above finished ground level and to the bottom of the wall cladding material. If fibre-reinforced cement sheets are used for this purpose, the sheets must have a minimum thickness of 6 mm (see Figure 3.7.4.1).
2. High bushfire attack category	
	As per requirements for category of medium bushfire attack.
3. Extreme bushfire attack category	
	As per requirements for category of medium bushfire attack except that, in the case of a framed floor, where any bearer or joist is greater than 600 mm above finished ground level and the floor is not enclosed, the bearer, joists and flooring must be fire-retardant-treated timber or sheeted underneath with <i>non-combustible</i> material.
SUPPORTING POSTS, COLUMNS, STUMPS, PIERS AND POLES (except in sub-floor spaces enclosed by one of the methods described in FLOORING SYSTEMS 1(d)(iii))	
1. Medium bushfire attack category	
(a)	<i>Non-combustible</i> material.
(b)	Fire-retardant-treated timber for not less than 400 mm above <i>finished ground level</i> .
(c)	Timber mounted on metal stirrups with a clearance of not less than 75 mm above finished ground or paving level (see Figure 3.7.4.2).
2. High bushfire attack category	
	As per requirements for category of medium bushfire attack.
3. Extreme bushfire attack category	
	As per requirements for category of medium bushfire attack except that all timber shall be fire-retardant-treated timber.
EXTERNAL WALLS	
1. Medium bushfire attack category	
(a)	Masonry, concrete or earthwall construction for the external leaf.
(b)	Framed wall with- <ul style="list-style-type: none"> (i) sarking having a <i>Flammability Index</i> of not more than 5; or (ii) an insulation material conforming with the appropriate standard for that material.
(c)	Timber logs with all joints between the logs gauge-planed and sealed.
(d)	<i>Combustible</i> sheet cladding provided that the cladding within 400 mm of the finished ground or paving level is covered by, or substituted with- <ul style="list-style-type: none"> (i) <i>non-combustible</i> sheet material; or (ii) fire-retardant-treated timber.

Amdt 11

Table 3.7.4.1	
CONSTRUCTION FOR MEDIUM, HIGH AND EXTREME CATEGORIES OF BUSHFIRE ATTACK	
EXTERNAL WALLS (continued)	
2.	High bushfire attack category
As per requirements for category of medium bushfire attack, except that-	
(a) PVC cladding must not be used; and	
(b) timber wall cladding must be of fire-retardant-treated timber.	
3.	Extreme bushfire attack category
As per requirements for category of high bushfire attack.	
WINDOWS	
1.	Medium bushfire attack category
The openable part of a <i>window</i> , including louvres, must be screened with corrosion-resistant steel, bronze or aluminium mesh with a maximum aperture size of 1.8 mm.	
2.	High bushfire attack category
As per requirements for category of medium bushfire attack, except that-	
(a) where timber is used, it must be fire-retardant-treated timber, except where protected by <i>non-combustible</i> shutters; and	
(b) where leadlight <i>windows</i> are used, they must be protected by shutters made of <i>non-combustible</i> material or of toughened glass.	
(c) aluminium mesh must not be used in the <i>window</i> screens.	
3.	Extreme bushfire attack category
As per requirements for category of high bushfire attack except that if the <i>windows</i> are not protected by <i>non-combustible</i> shutters, they shall be glazed with toughened glass.	
EXTERNAL DOORS	
1.	Medium bushfire attack category
External doors must be fitted with-	
(a) weather strips or draught excluders to prevent the build-up of burning debris beneath the door; and	
(b) tight-fitting screen doors with corrosion-resistant steel, bronze or aluminium mesh with a maximum aperture size of 1.8 mm.	
2.	High bushfire attack category
As per requirements for category of medium bushfire attack, except that-	
(a) aluminium mesh must not be used in the screen door; and	
(b) if leadlight glazing panels are used in the door, they must be protected by shutters made from <i>non-combustible</i> material or of toughened glass.	
3.	Extreme bushfire attack category
As per requirements for category of high bushfire attack, except that-	
(a) timber doors must be fire-retardant-treated timber or have a <i>non-combustible</i> covering on the exterior surface; or	
(b) doors must be protected by <i>non-combustible</i> shutters; or	
(c) doors must be solid-core having a minimum thickness of 35 mm.	

Amdt 11

Table 3.7.4.1 CONSTRUCTION FOR MEDIUM, HIGH AND EXTREME CATEGORIES OF BUSHFIRE ATTACK	
VENTS AND WEEPHOLES	
1. Medium bushfire attack category	Vents and weepholes must be protected with spark guards made from corrosion-resistant steel, bronze or aluminium mesh with a maximum aperture size of 1.8 mm.
2. High bushfire attack category	As per requirements for category of medium bushfire attack, except that aluminium mesh must not be used in the spark guards.
3. Extreme bushfire attack category	As per requirements for category of high bushfire attack.
ROOF COVERING, EAVES AND FASCIAS	
1. Medium bushfire attack category	<ul style="list-style-type: none"> (a) Timber shakes or shingles must not be used for the roof covering. (b) Sheet roofing must be metal or fibre-reinforced cement. (c) Gaps under corrugations or ribs of sheet roofing must be sealed or protected at the wall or fascia line by- <ul style="list-style-type: none"> (i) fully sarking the roof; or (ii) providing corrosion-resistant steel or bronze mesh with a maximum aperture size of 1.8 mm, profiled metal sheet, neoprene seal or compressed mineral wool. (d) Rib caps and ridge capping on sheet roofing must be preformed or the gaps between the capping and the sheeting sealed or protected in accordance with (c). (e) The roof/wall junction must be sealed by- <ul style="list-style-type: none"> (i) the use of fascia and eaves lining; or (ii) sealing the gaps between the rafters at the line of the wall with a <i>non-combustible</i> material (see Figure 3.7.4.3). (f) Tiled roofs must be fully sarked, including the ridge, and the sarking must be located directly beneath the tiling battens. (g) Any sarking used in the roof must have a <i>Flammability Index</i> of not more than 5.
2. High bushfire attack category	<p>As per requirements for category of medium bushfire attack, except that-</p> <ul style="list-style-type: none"> (a) all roof sheeting must be <i>non-combustible</i> and sarked; and (b) timber eaves lining and joining strips must be of fire-retardant-treated timber (see Figure 3.7.4.3); and (c) fascias must be <i>non-combustible</i> or of fire-retardant-treated timber (see Figure 3.7.4.3).
3. Extreme bushfire attack category	<p>As per requirements for category of high bushfire attack, except that-</p> <ul style="list-style-type: none"> (a) fibre-reinforced cement or aluminium sheet must not be used for roof sheeting or fascias; and (b) aluminium must not be used for eaves linings.

Amdt 11

Table 3.7.4.1	
CONSTRUCTION FOR MEDIUM, HIGH AND EXTREME CATEGORIES OF BUSHFIRE ATTACK	
ROOFLIGHTS	
1. Medium bushfire attack category	(a) Rooflight penetrations and associated shafts through the roof space must be sealed with a <i>non-combustible</i> sleeve or lining (see Figure 3.7.4.4). (b) A rooflight may consist of thermoplastic sheet in a metal frame, provided that the diffuser at ceiling level is of wired or toughened glass in a metal frame. (c) Openings in ventilated rooflights must be provided with corrosion-resistant steel or bronze mesh having a maximum aperture size of 1.8 mm.
2. High bushfire attack category	As per requirements for category of medium bushfire attack, except that rooflight glazing must be of wired glass. Thermoplastic material or toughened glass must not be used.
3. Extreme bushfire attack category	As per requirements for category of high bushfire attack.
ROOF VENTILATORS	
1. Medium bushfire attack category	All components of roof ventilators, including rotary ventilators, must be of <i>non-combustible</i> material and have ventilation openings protected by corrosion-resistant steel or bronze mesh having a maximum aperture size of 1.8 mm.
2. High bushfire attack category	As per requirements for category of medium bushfire attack.
3. Extreme bushfire attack category	As per requirements for category of medium bushfire attack.

Amdt 11

Table 3.7.4.1 CONSTRUCTION FOR MEDIUM, HIGH AND EXTREME CATEGORIES OF BUSHFIRE ATTACK	
ROOF-MOUNTED EVAPORATIVE COOLING UNITS	
1. Medium bushfire attack category	All openings into the cooling unit must be protected by corrosion-resistant steel or bronze mesh with a maximum aperture size of 1.8 mm.
2. High bushfire attack category	As per requirements for category of medium bushfire attack, except that the outer case of the evaporative cooling unit must be of <i>non-combustible</i> material.
3. Extreme bushfire attack category	As per requirements for category of high bushfire attack.
GUTTERS AND DOWNPIPES	
1. Medium bushfire attack category	Materials or devices used to stop leaves collecting in gutters must have a <i>Flammability Index</i> of not more than 5.
2. High bushfire attack category	As per requirements for category of medium bushfire attack.
3. Extreme bushfire attack category	As per requirements for category of medium bushfire attack.
SERVICE PIPES (water and gas)	
1. Medium bushfire attack category	Piping for water and gas supplies must- (a) be buried to a depth of not less than 300 mm below finished ground level; or (b) be of metal.
2. High bushfire attack category	As per requirements for category of medium bushfire attack.
3. Extreme bushfire attack category	As per requirements for category of medium bushfire attack.
VERANDAHS AND DECKS	
1. Medium bushfire attack category	(a) Slab on ground or suspended concrete slab. (b) Any supporting posts or columns must comply with the requirements of this table for supporting posts, columns stumps, piers and poles. (c) Any supporting walls must comply with the requirements of this table for <i>external walls</i> . (d) Where sheeted or tongue and grooved solid flooring is used, the flooring system must comply with the requirements of this table for flooring systems. (e) Where spaced timber deck flooring is used- (i) the gap between the timber deck flooring must be not less than 5 mm; and (ii) to facilitate access for extinguishment, the perimeter of the deck must not be enclosed or access to the space beneath the deck impeded; and (iii) the timber deck flooring must be separated from the remainder of the building in a manner that will not spread fire into the building.

Amdt 11

Table 3.7.4.1 CONSTRUCTION FOR MEDIUM, HIGH AND EXTREME CATEGORIES OF BUSHFIRE ATTACK VERANDAHS AND DECKS (continued)	
2. High bushfire attack category	
As per requirements for category of medium bushfire attack, except that if spaced timber deck flooring is used, fire-retardant-treated timber must be used for the decking material.	
3. Extreme bushfire attack category	
As per requirements for category of high bushfire attack, except that all materials (including any balustrades) must be <i>non-combustible</i> or if timber is used, it must be fire-retardant-treated.	

Figure 3.7.4.1
Amdt No. 9

**Figure 3.7.4.1
PROTECTION OF SUB-FLOOR SPACES WITH LESS THAN 600 MM CLEARANCE**

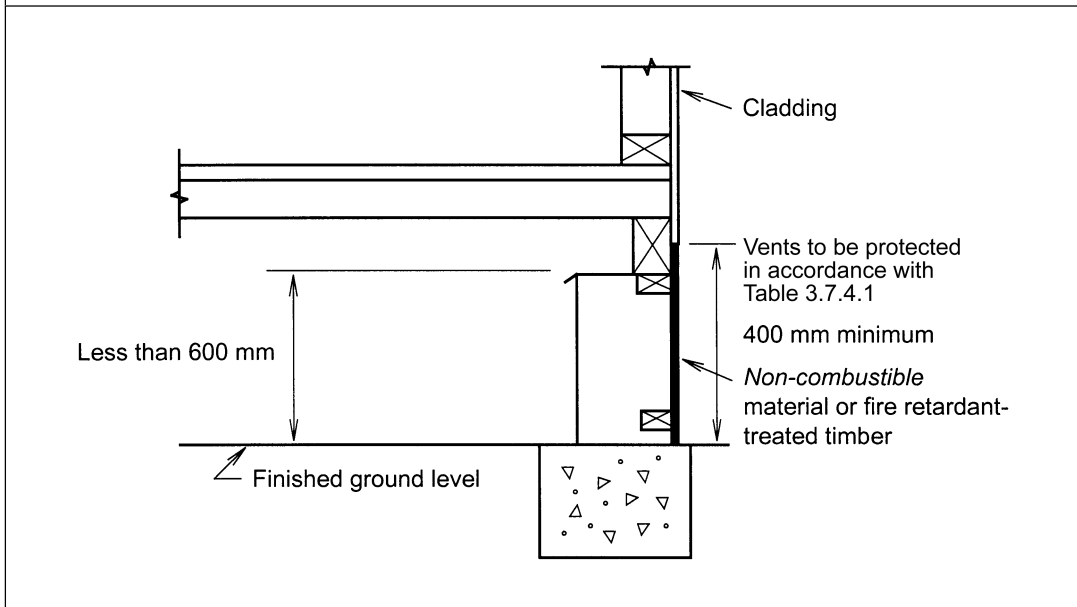

Amdt 11

Figure 3.7.4.2
Amdt No. 9

Figure 3.7.4.2
METAL STIRRUP CLEARANCE

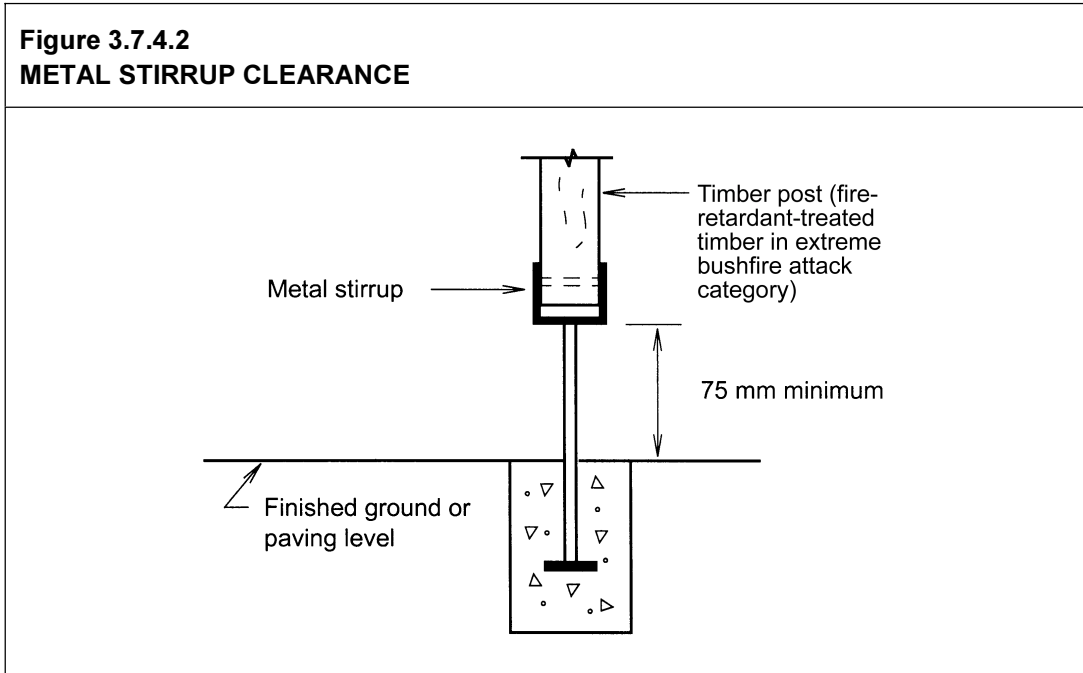

Amdt 11

Figure 3.7.4.3
Amdt No. 9

Figure 3.7.4.3
SEALING OF ROOF/WALL JUNCTION

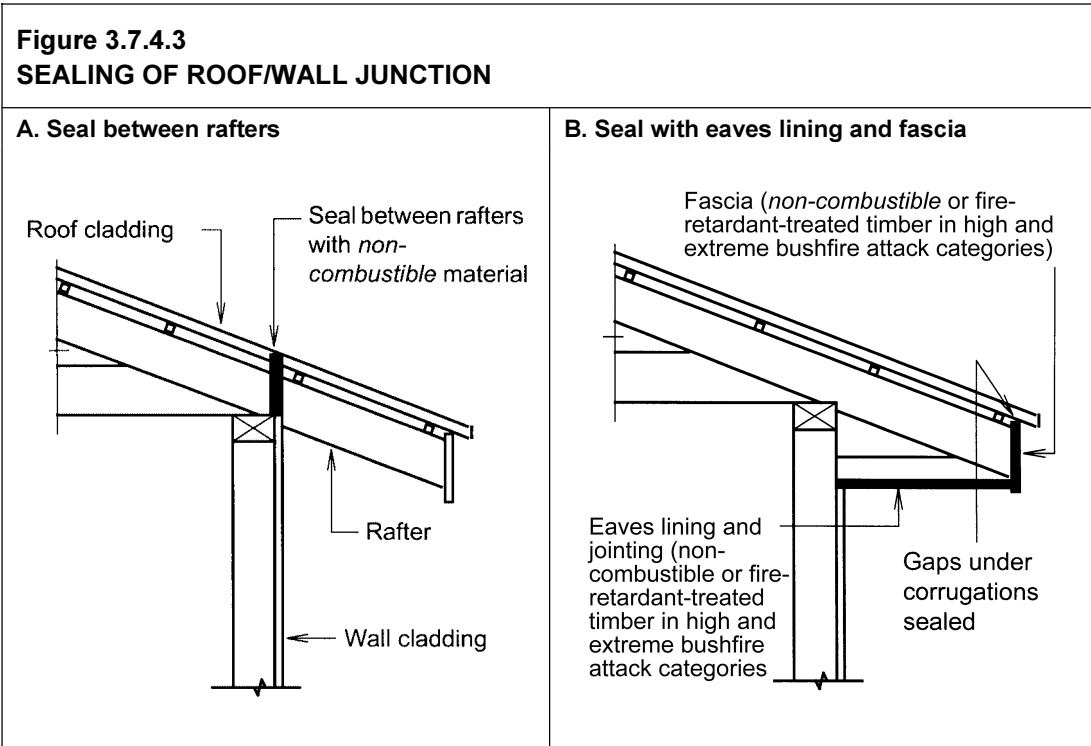
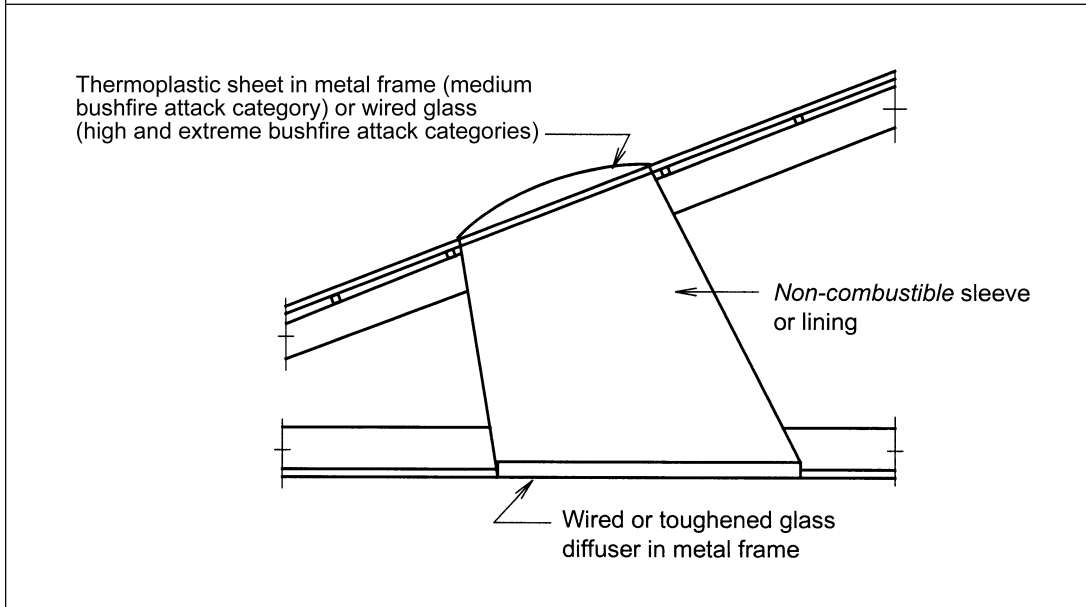

Figure
3.7.4.4
Amdt No. 9

Figure 3.7.4.4
ROOFLIGHTS



Explanatory information:

Sub-floor spaces: The method of treating sub-floor spaces is determined by whether sufficient access is available for extinguishment of burning debris that may accumulate beneath the floor. A height of 600 mm has been selected as providing reasonable access for that purpose.

Fully sarked roofs: Where roofing systems are fully sarked, it may be necessary to provide ventilation to prevent moisture condensation from occurring in the roof space. If vents are provided, care needs to be taken to ensure that sparks and embers cannot enter the roof space via the openings.

Termite risk management: If the subject building is *required* to be provided with termite risk management measures, particular care should be taken to ensure that the construction requirements of this Part do not compromise such measures. Details for enclosure of sub-floor spaces and for the protection of *combustible* wall cladding near ground level in particular, may provide a means for concealed access to the building by subterranean termites.

Amdt 11

Figure 3.7.4.5
Amdt No. 11

Figure 3.7.4.5
EXTERNAL TIMBERS REGARDED AS PROTECTED

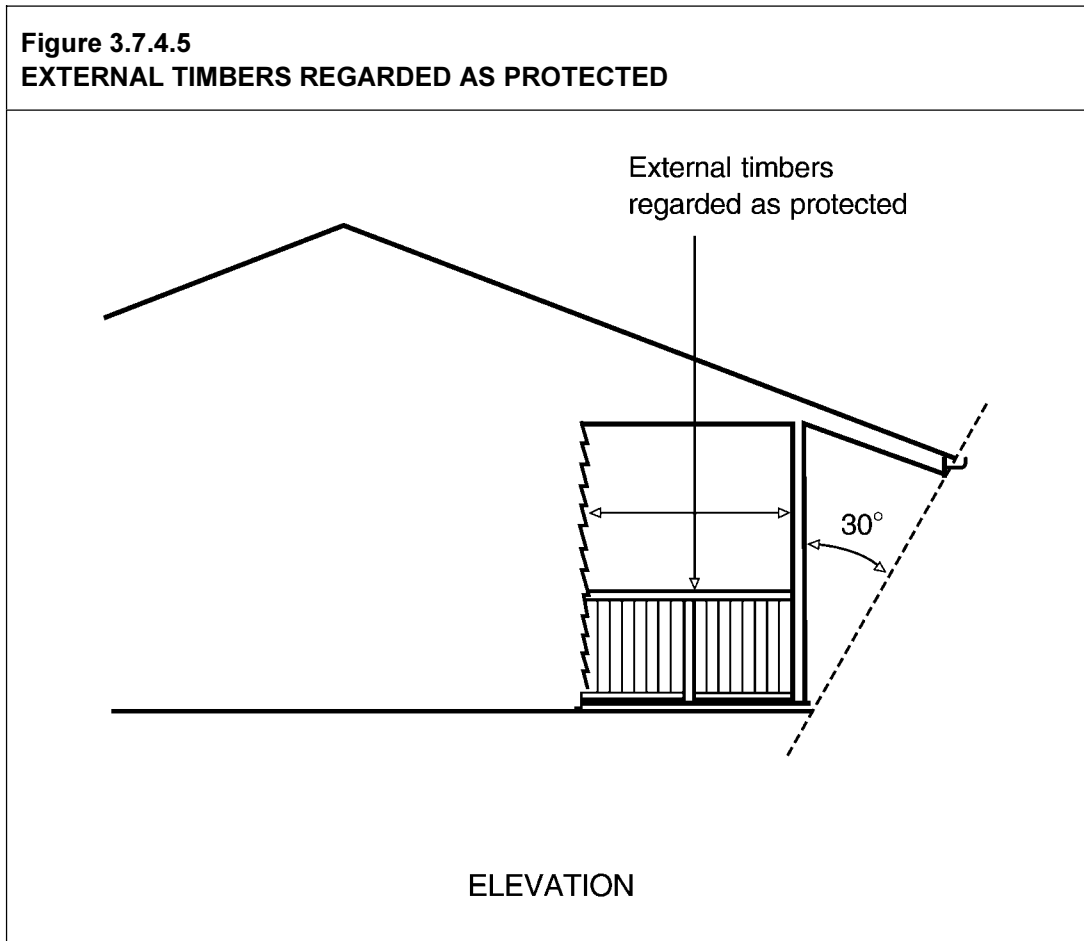

Amdt 11

PART 3.7.5 ALPINE AREAS

Appropriate Performance Requirements:

Where an alternative *alpine area* egress design is proposed to that described in Part 3.7.5, that proposal must comply with *Performance Requirement P2.3.5* in Section 2.

Acceptable construction practice

3.7.5.1 Application

Compliance with this Part for buildings which are located in *alpine areas* (see Figure 3.7.5.2) satisfies *Performance Requirement P2.3.5*.

3.7.5.2 External doorways

An external door in a building constructed in an *alpine area*, which may be subject to a build-up of snow must-

- (a) open inwards; and
- (b) be marked "OPEN INWARDS" on the inside face of the door in letters not less than 75 mm high and in a colour contrasting with that of the background; and
- (c) if it serves a corridor or stairway, be positioned in an alcove or recess with-
 - (A) no horizontal dimension of the alcove or recess less than twice the width of the door; and
 - (B) the door positioned to open against a wall such that the distance from any part of its swing to the nearest point of entry of the stairway or corridor is not less than the width of the door.

3.7.5.3 External ramps

An external ramp serving an external doorway must have a gradient not steeper than 1:12.

3.7.5.4 Discharge of external doorways providing a means of egress

A building in an *alpine area* must be constructed so that-

- (a) for any *external walls* more than 3.6 m above the natural ground level, the distance of that part of the building from the allotment boundary (other than a road alignment) must be not less than 2.5 m plus 100 mm for each 300 mm or part by which that part of the *external wall* exceeds a height of 3.6 m; and
- (b) an external doorway may discharge into a court between wings of a building provided the wings are at least 6 m apart; and

- (c) where an external doorway discharges opposite a barrier or embankment which is more than 900 mm above the threshold of that doorway, the distance between the threshold and the barrier is not less than twice the height of the barrier or 6 m, whichever is the lesser (see Figure 3.7.5.3).

3.7.5.5 External trafficable structures

External stairways, ramps, access bridges or other trafficable structures serving the building must have-

- (a) a floor surface that consists of steel mesh or other suitable material if it is used as a means of egress; and
- (b) any required balustrade or other barrier constructed so that its sides are not less than 75% open.

3.7.5.5(b)
Amdt No. 5

Amdt 11

**Figure 3.7.5.1
DESIGN FOR SAFE EGRESS IN ALPINE AREAS – MINIMUM DIMENSIONS OF ALCOVE OR RECESS AT EXTERNAL DOORWAY**

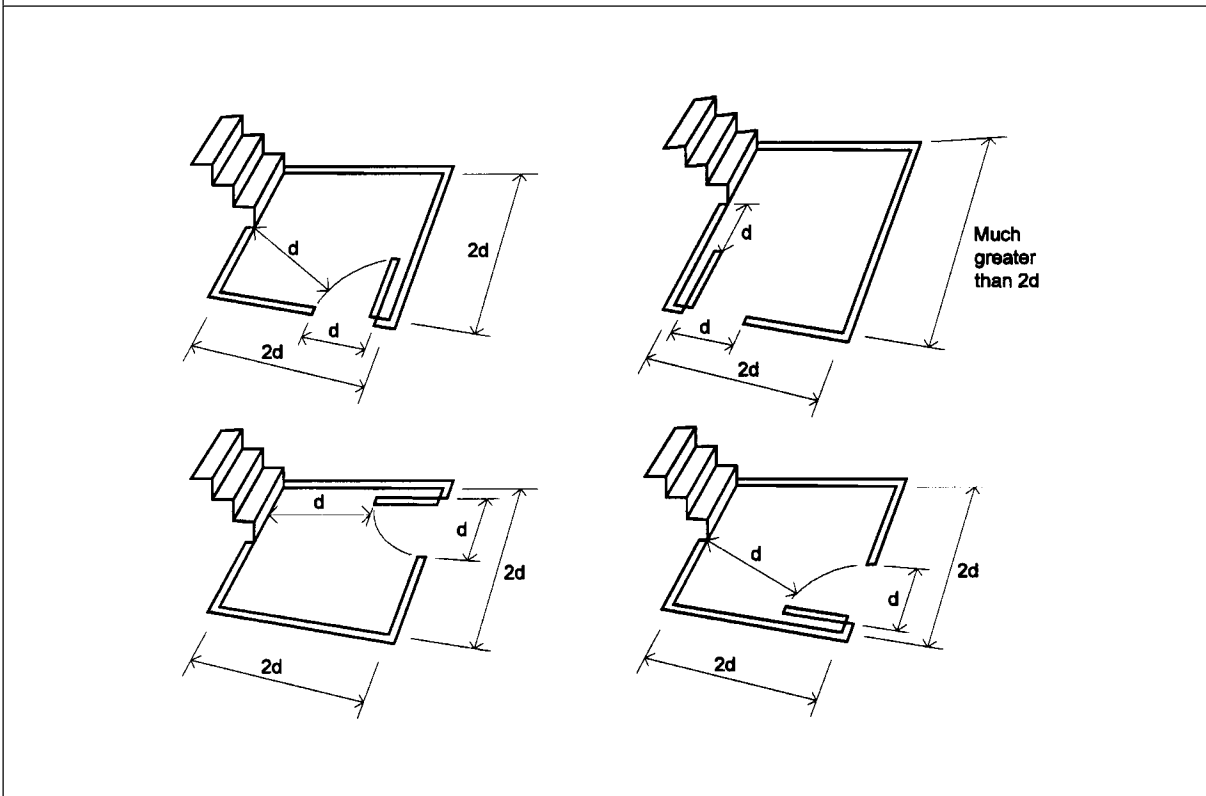
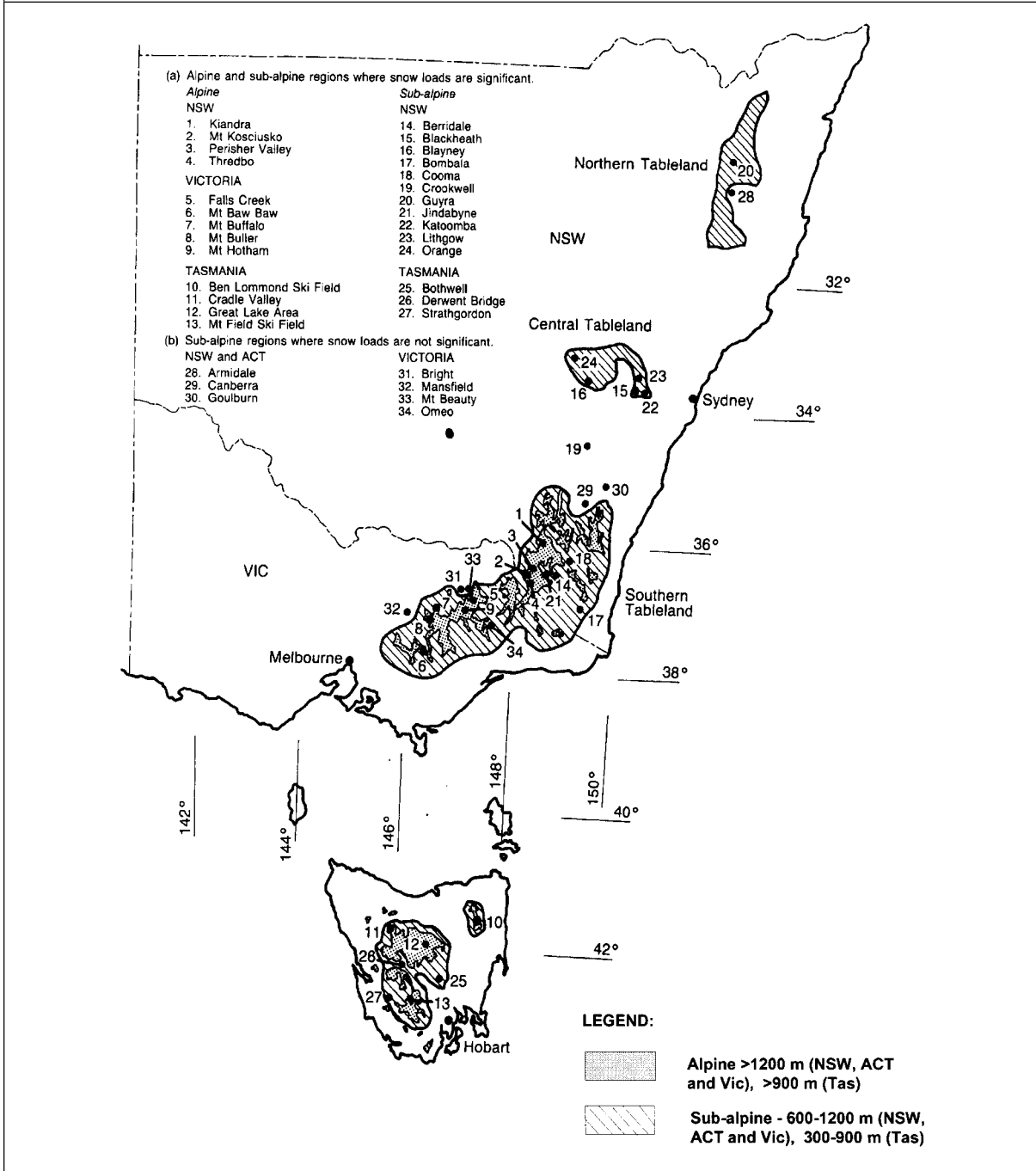

Figure 3.7.5.2
ALPINE AREAS



Amdt 11

Explanatory information:

Alpine and sub-alpine areas are located in ACT, NSW, Victoria and Tasmania.

Alpine areas are areas 1200 m or more above Australian Height Datum (AHD) for NSW, ACT and Victoria, and 900 m or more above AHD for Tasmania, as shown in Figure 3.7.5.2.

Significant snowfalls (snowfalls which result in an average snow accumulation on the ground of 175 mm or greater) may occur in the sub-alpine areas shown in Figure 3.7.5.2. Part 3.7.5 does not apply to those areas because, unlike alpine areas, successive snowfalls are not likely to accumulate.

It is noted that in the ACT, the Canberra area is designated as a sub-alpine region where snow loads are not considered significant.

Amdt 11

**Figure 3.7.5.3
DESIGN FOR SAFE EGRESS IN ALPINE AREAS – DISCHARGE OF EXTERNAL DOORWAY**

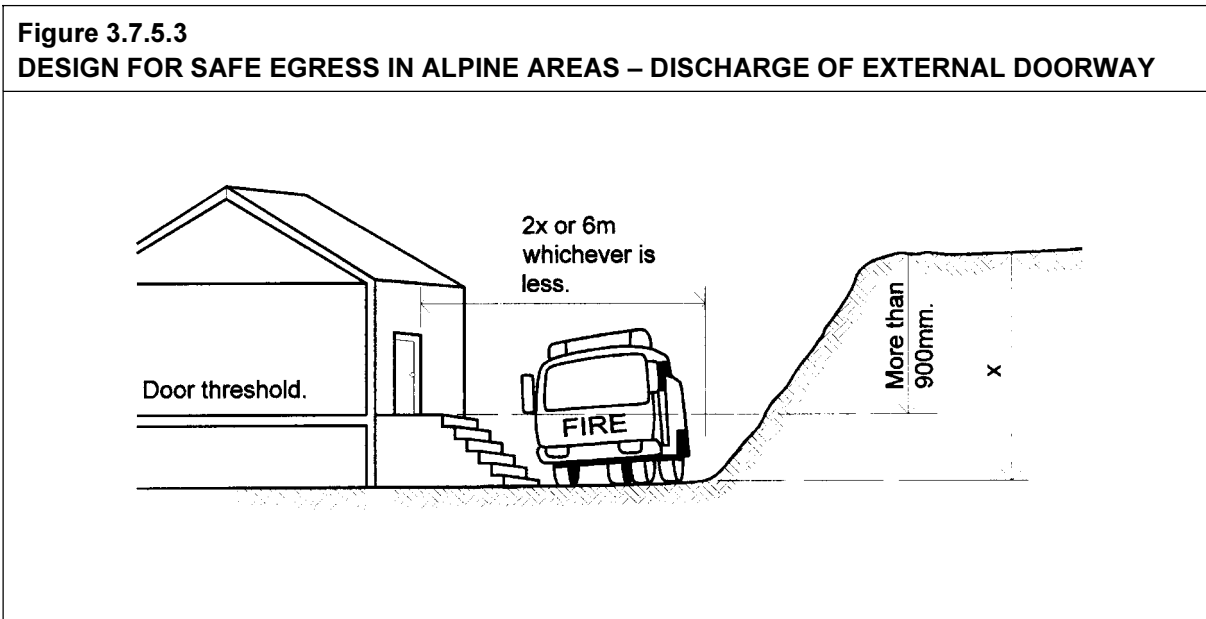

PART **3.8**

Amdt 11

HEALTH AND AMENITY

- 3.8.1 Wet Areas**
- 3.8.2 Room Heights**
- 3.8.3 Facilities**
- 3.8.4 Light**
- 3.8.5 Ventilation**
- 3.8.6 Sound Insulation**

PART 3.8 HEALTH AND AMENITY

	Page
3.8.1 Wet areas	19,021
3.8.1 Definitions	
3.8.1.0 Acceptable construction manual	
3.8.1.1 Application	
3.8.1.2 Wet areas	
3.8.1.3 Materials - general	
3.8.1.4 Protection of shower floors in wet areas	
3.8.1.5 Protection of walls in wet areas	
3.8.1.6 Sealing of wall and floor junctions and joints	
3.8.2 Room heights	19,301
3.8.2.1 Application	
3.8.2.2 Ceiling heights	
3.8.3 Facilities	19,501
3.8.3.1 Application	
3.8.3.2 Required facilities	
3.8.3.3 Construction of sanitary compartments	
3.8.4 Light	19,701
3.8.4.1 Application	
3.8.4.2 Natural lighting	
3.8.4.3 Artificial lighting	
3.8.5 Ventilation	19,901
3.8.5.0 Acceptable construction manual	
3.8.5.1 Application	
3.8.5.2 Ventilation requirements	
3.8.5.3 Location of sanitary compartments	
3.8.6 Sound insulation	20,101
3.8.6.1 Application	
3.8.6.2 Sound insulation requirements	
3.8.6.3 General installation requirements for walls	
3.8.6.4 Soil and waste pipes	

PART 3.8.1 WET AREAS

Appropriate Performance Requirements:

Where an alternative system for protecting *wet areas* in a building is proposed to that described in Part 3.8.1, that proposal must comply with *Performance Requirement P2.4.1*.

Definitions:

3.8.1 Definitions used in this Part are as follows:

Enclosed shower means a shower area enclosed for a height of 1.8 m above the shower floor area by water resistant walls, glazed panels or doors, metal framed shower screens, curtain or other similar materials that will control the spread of water.

Prefinished shower base means a *waterproof* preformed prefinished shower base which is installed as the finished floor of a shower compartment.

Shower tray means a *waterproof* liner which is installed in the shower compartment prior to the application of the floor and wall finishing system.

Waterproof means that a system or material will not allow the penetration of water.

Waterproof membrane means an applied *waterproof* barrier that is installed in the shower compartment.

Water resistant means a system or material that will restrict water migration.

Wet area means an area as defined in 3.8.1.2, within a building supplied with water from a water supply system and includes bathrooms, showers, laundries, *sanitary compartments* and the like.

Wet area fixture means a bath, laundry trough, basin, sink or similar fixture designed to contain water.

A. Acceptable construction manual

3.8.1.0 *Performance Requirement P2.4.1* is satisfied for *wet areas* in Class 1 and 10 buildings if they are *waterproofed* in accordance with AS 3740 - Waterproofing of wet areas within residential buildings.

SA variation
Amdt No. 3

STATE AND TERRITORY VARIATIONS

3.8.1 does not apply in South Australia and 3.8.1.0 is replaced in South Australia with the following clause.

Performance Requirements P2.4.1 and SA 3.1 are satisfied for *wet areas* in Class 1 and 10 buildings if they are waterproofed in accordance with Minister's Specification SA F1.7 - Waterproofing of wet areas in buildings.

Amdt 11

B. Acceptable construction practice
--

3.8.1.1 Application

Compliance with this Part satisfies *Performance Requirement P2.4.1* for *wet areas* provided the *wet area*-

- (a) is protected in accordance with the appropriate requirements of 3.8.1.3, 3.8.1.4, 3.8.1.5 and 3.8.1.6; and
- (b) complies with the appropriate details described in Figures 3.8.1.5 to 3.8.1.11.

STATE AND TERRITORY VARIATIONS

3.8.1.1 does not apply in South Australia and is replaced in South Australia with SA 3.2.1.

Amdt 11

3.8.1.2 Wet areas

The following areas of a building must be protected against water in accordance with 3.8.1.3 to 3.8.1.6 as appropriate:

- (a) Shower floor areas must comply with the following:
 - (i) Shower floors with a hob or set down:
 - (A) Within an *enclosed shower* (see Figure 3.8.1.1)-
 - (aa) to the outer face of the hob; or
 - (bb) where there is a set down of not less than 25 mm to the shower, 100 mm past the outside of the set down.
 - (B) Where there is no *enclosed shower*, the area within 1.5 m radius measured horizontally from a point on the floor vertically below the shower rose (see Figure 3.8.1.1).
 - (ii) Floors adjacent to showers located above baths with no enclosure - the area within 1.5 m of the shower rose (see Figure 3.8.1.2).
 - (iii) Shower floors with no hob, 25 mm set down, or floor angle (see Figure 3.8.1.9) - the whole floor of the room.
- (b) Walls (including corner junctions)-
 - (i) within an *enclosed shower* (see Figure 3.8.1.1); or
 - (ii) where the shower is not an *enclosed shower*, within 1.5 m of the shower fitting, to a height of 1.8 m above the floor (see Figure 3.8.1.1); and
 - (iii) immediately adjacent or behind a *wet area fixture*-
 - (A) to a height not less than 150 mm above the fixture if the fixture is within 75 mm of the wall; and

Amdt No. 2

- (B) for the full width and/or breadth of the fixture (see Figure 3.8.1.3).
- (c) Floor, wall and bench junctions must comply with the following:
 - (i) The junction between the floor and wall-
 - (A) if the wall and floor are *required* to be protected; and
 - (B) in bathrooms containing showers.
 - (ii) The junction between the wall and any bench top or horizontal surface containing a *wet area fixture* if the wall is *required* to be protected.

Figure 3.8.1.1
ENCLOSED AND UNENCLOSED SHOWER – AREA TO BE PROTECTED

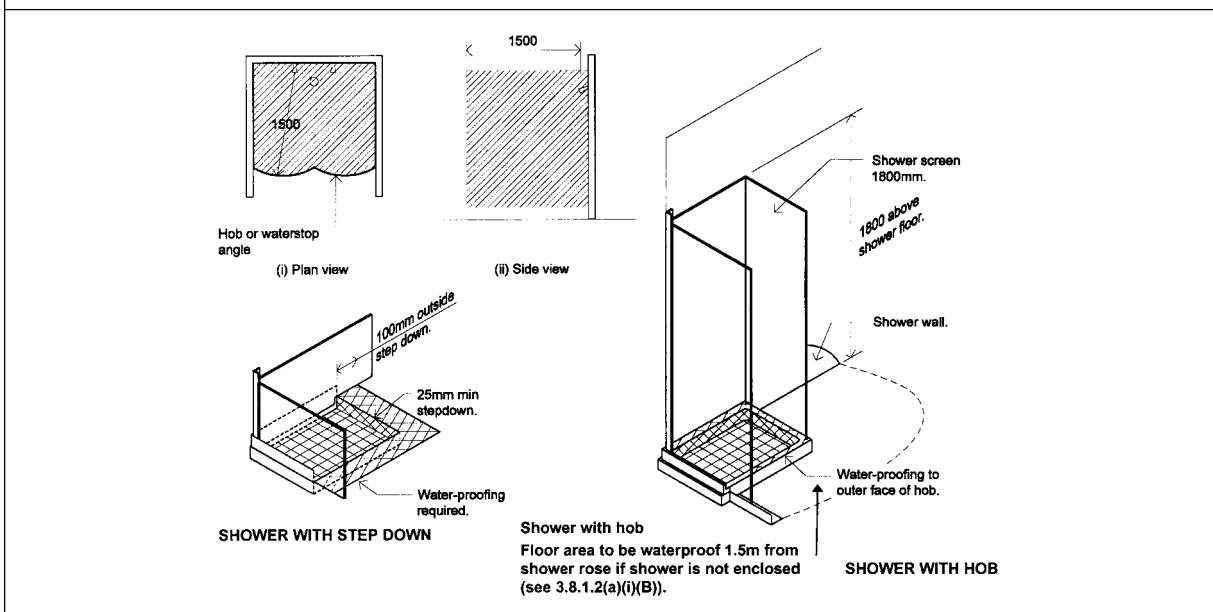

Amdt 11

Figure 3.8.1.2
SHOWERS ABOVE BATHS – AREA TO BE PROTECTED

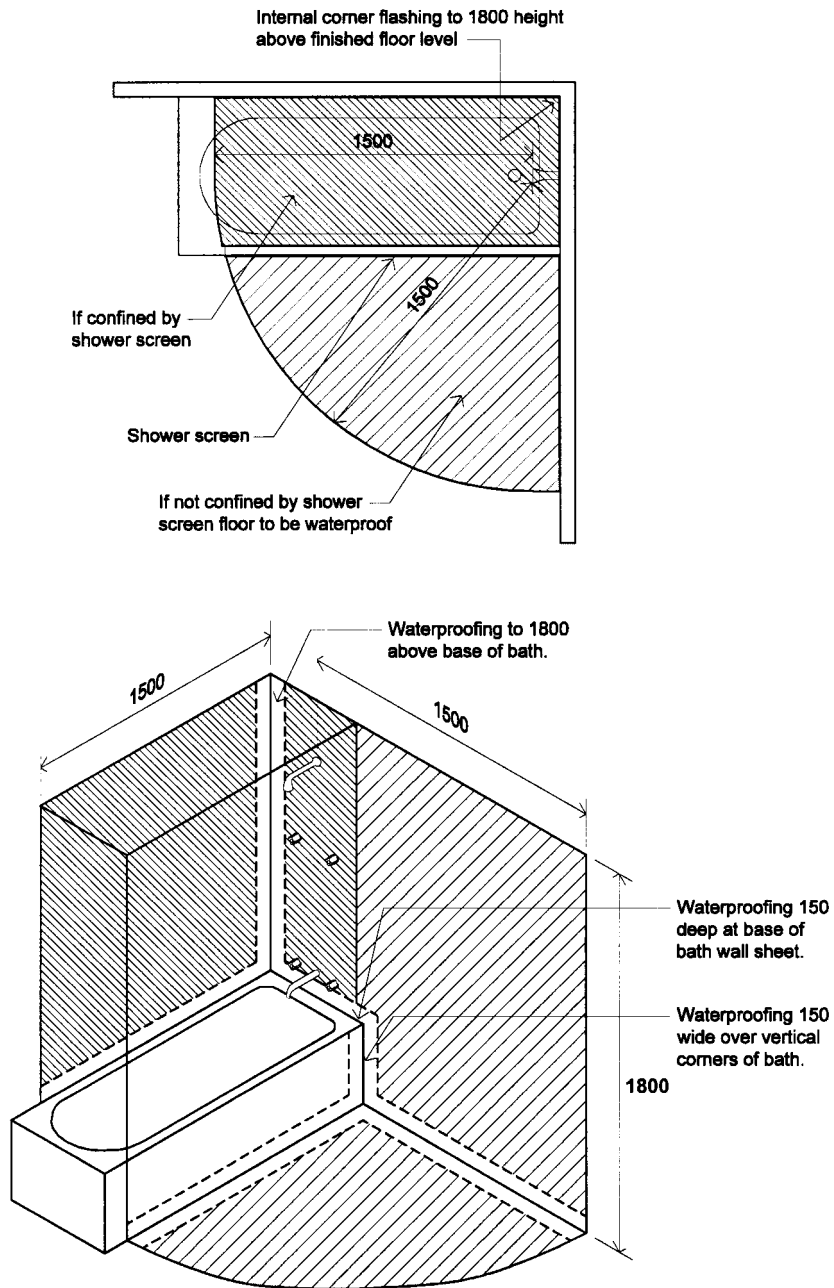

Amdt 11

Figure 3.8.1.3
BATH AND WALL FIXTURES – AREA TO BE PROTECTED

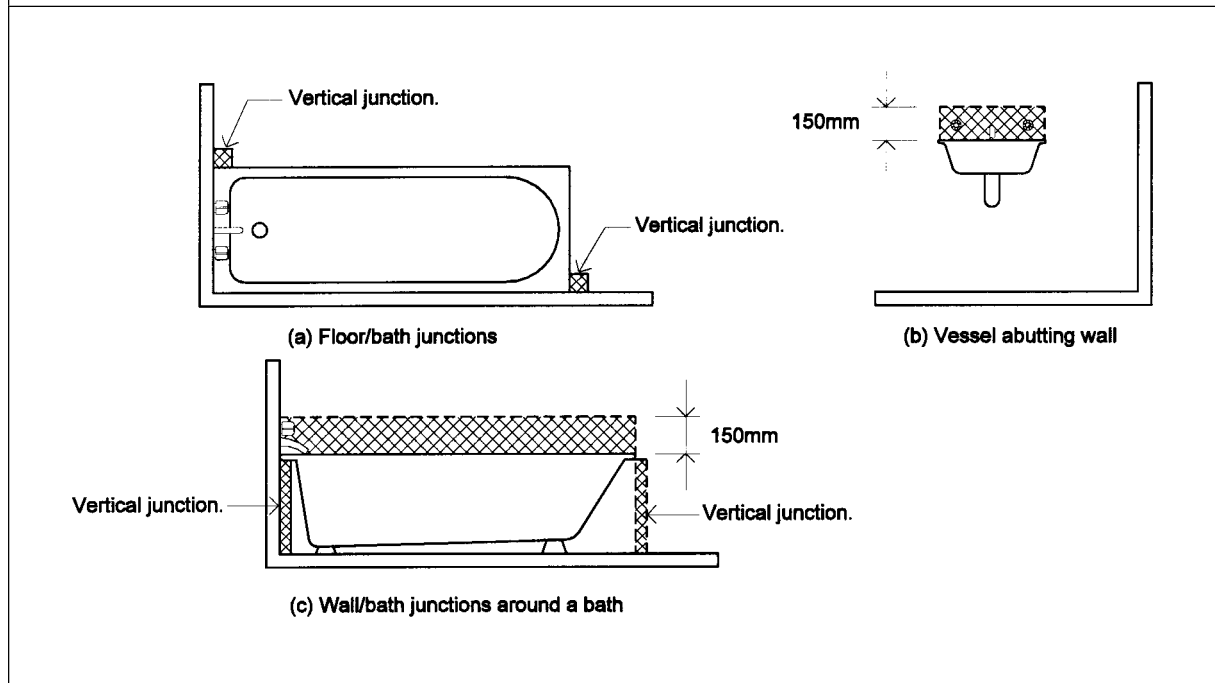

Amdt 11

3.8.1.3 Materials - general

3.8.1.3
Amdt No. 4

Materials used in *wet area waterproofing* and *water resistant* construction must be as follows:

- (a) Flashing angles must be *waterproof* and have dimensions not less than-
 - (i) for wall angles - 40x40 mm; and
 - (ii) for floor angles - 25 mm above finished adjoining floor level x 50 mm.
- (b) Grout used for ceramic tiles must have suitable properties for the intended use based upon the workability, shrinkage, general adhesion and be one of the following grout types:
 - (i) Cement based grout mix in accordance with the following:
 - (A) Wall tiles - grout must be 1 part portland cement based grout which is compressible.
 - (B) Floor tiles - grout must be 1 part portland cement and 2-4 parts sand mixed with water to a stiff consistency. Up to 1/5 part lime may be added if additional workability is required. Other admixtures should only be used in accordance with suitable recommendations.

- (ii) Proprietary cement based grout must be in accordance with the suitable recommendation for the type of tile proposed.
- (c) Flexible sealants must be *waterproof*, neutral, self curing, flexible and mould resisting and must be compatible with the adjoining materials.

3.8.1.4 Protection of shower floors in wet areas

The shower floor area as defined in 3.8.1.2(a) must-

- (a) be *waterproofed* in accordance with one of the following systems:
 - (i) A *shower tray* with sides which are the greater of-
 - (A) 100 mm above the finished floor surface; and
 - (B) 75 mm above the adjoining structural floor level; and
 - (C) 25 mm above the maximum possible water level of the shower compartment; or
 - (ii) a *waterproof membrane* extending 100 mm up the adjoining shower or bathroom area walls and turned down into a drainage flange; or
 - (iii) a *prefinished shower base*.
- (b) in shower areas (other than outside a bath), have a grade of not less than 1:60 to the shower trap or drainage flange; and
- (c) be finished with grouted glazed tiles-
 - (i) adhered to the floor substrate; or
 - (ii) bedded in mortar.

3.8.1.5 Protection of walls in wet areas

Wet area walls as defined in 3.8.1.2(b) must-

- (a) be *water resistant*, consisting of-
 - (i) smooth steel float finished concrete; or
 - (ii) cement render not less than 10 mm thick with a hard smooth finish; or
 - (iii) terrazzo; or
 - (iv) Pre-finished wall panels sealed with a flexible sealant at joints; or
- (b) consist of a *water resistant* lining suitably attached or adhered to a *water resistant* substrate with all joints sealed in accordance with 3.8.1.6; and
 - (i) for the purpose of this clause, suitable *water resistant* wall substrates are-
 - (A) *wet area* plasterboard sheet; or
 - (B) fibre cement sheet; or
 - (C) masonry; and

- (ii) suitable *water resistant* wall linings are-
 - (A) ceramic tiles; or
 - (B) slate; or
 - (C) stone tiles; or
 - (D) sheet vinyl with a thickness not less than 1 mm wear layer, fully bonded to the substrate, with joints welded or seam-sealed.

3.8.1.6 Sealing of wall and floor junctions and joints

Wall, floor and bench junctions as defined in 3.8.1.2(c) and wall joints in *wet areas* must be sealed as follows:

- (a) Vertical wall junctions in shower areas must be-
 - (i) flashed; and
 - (ii) where the flashing is above a *shower tray* or membrane, it must be lapped inside the *shower tray* or membrane not less than 25 mm (where possible); and
 - (iii) for *wet area* plasterboard, reinforced with tape set in *water resistant* taping compound and sealed with *water resistant* sealer.
- (b) Horizontal and vertical joints (other than wall junctions) in *wet area* plasterboard must be reinforced with tape set in *water resistant* taping compound and sealed with *water resistant* sealant.
- (c) The junction between the wall and shower floor or bath must be sealed with a flexible sealant in accordance with Figure 3.8.1.11
- (d) The junction between the wall and *wet area fixtures* or benches containing a *wet area fixture* must be sealed with a flexible sealant in accordance with Figure 3.8.1.10.
- (e) Tap fittings in shower recesses must be sealed with flexible sealant or sealed with a *waterproof* flange in accordance Figure 3.8.1.6.
- (f) Finished wall and floor tile junctions must not be grouted, but sealed with a flexible sealant to create a flexible movement joint and the wall tiles must finish over the edge of the floor tiles (see Figure 3.8.1.8).

Amdt No. 2

3.8.1.6(b)
Amdt No. 2

Amdt 11

Figure 3.8.1.5
TYPICAL VIEW OF SHOWER RECESS AND LINING MATERIALS

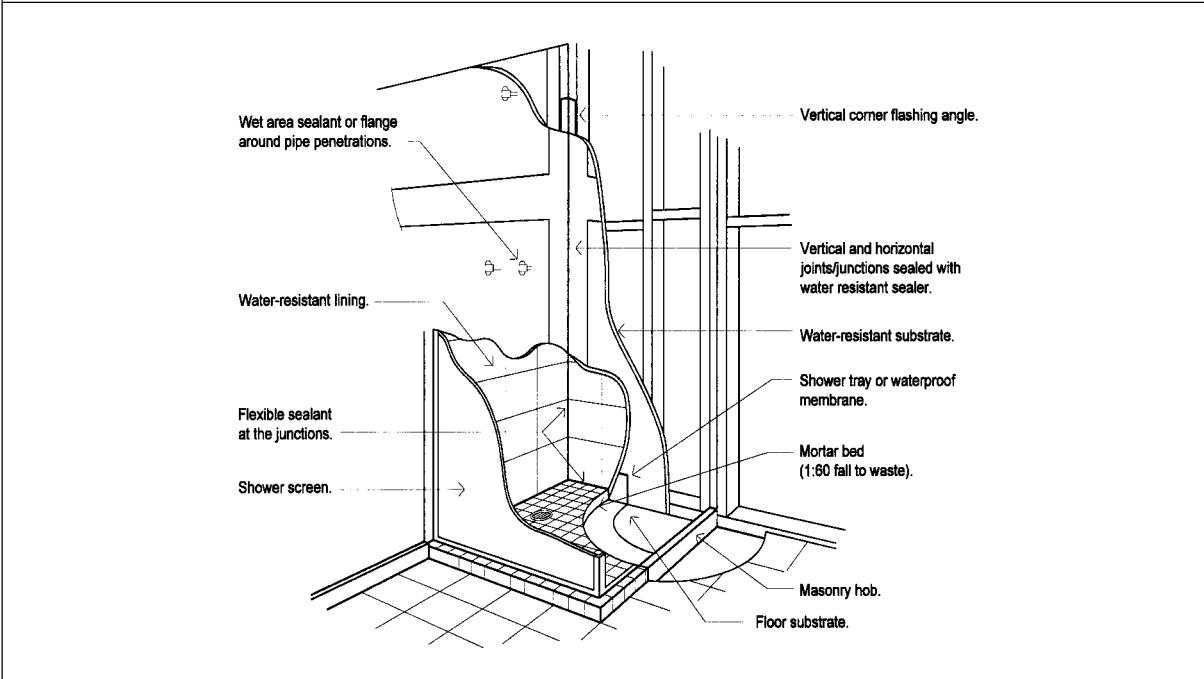

Amdt 11

Figure 3.8.1.6
TYPICAL INSTALLATION OF TAP FLANGE

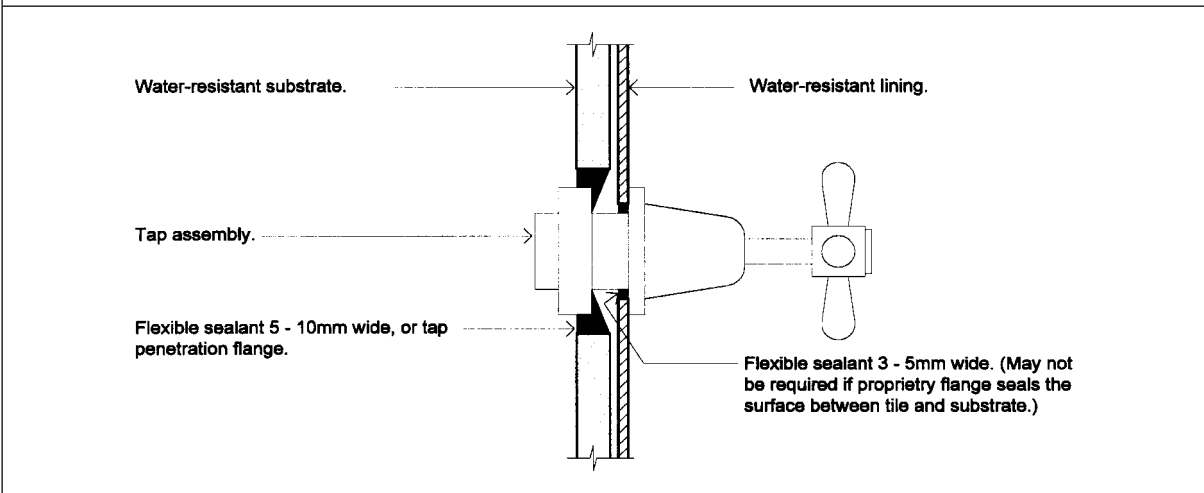
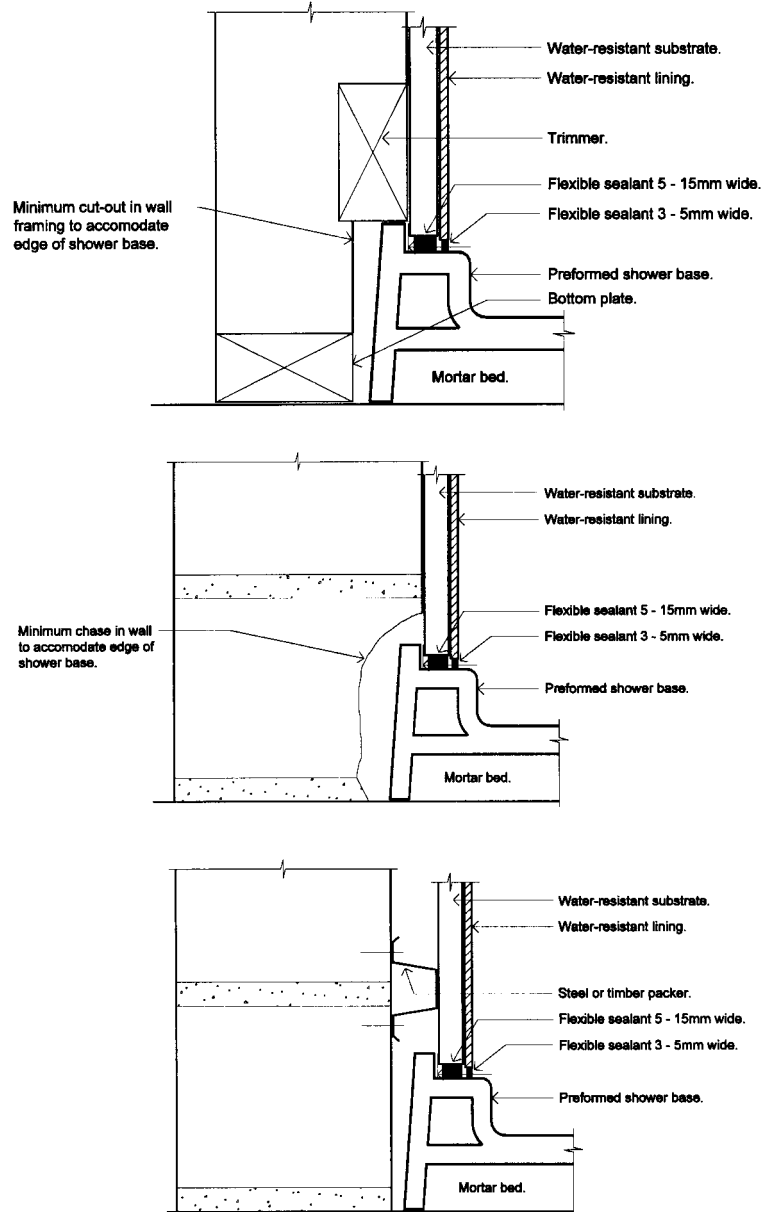
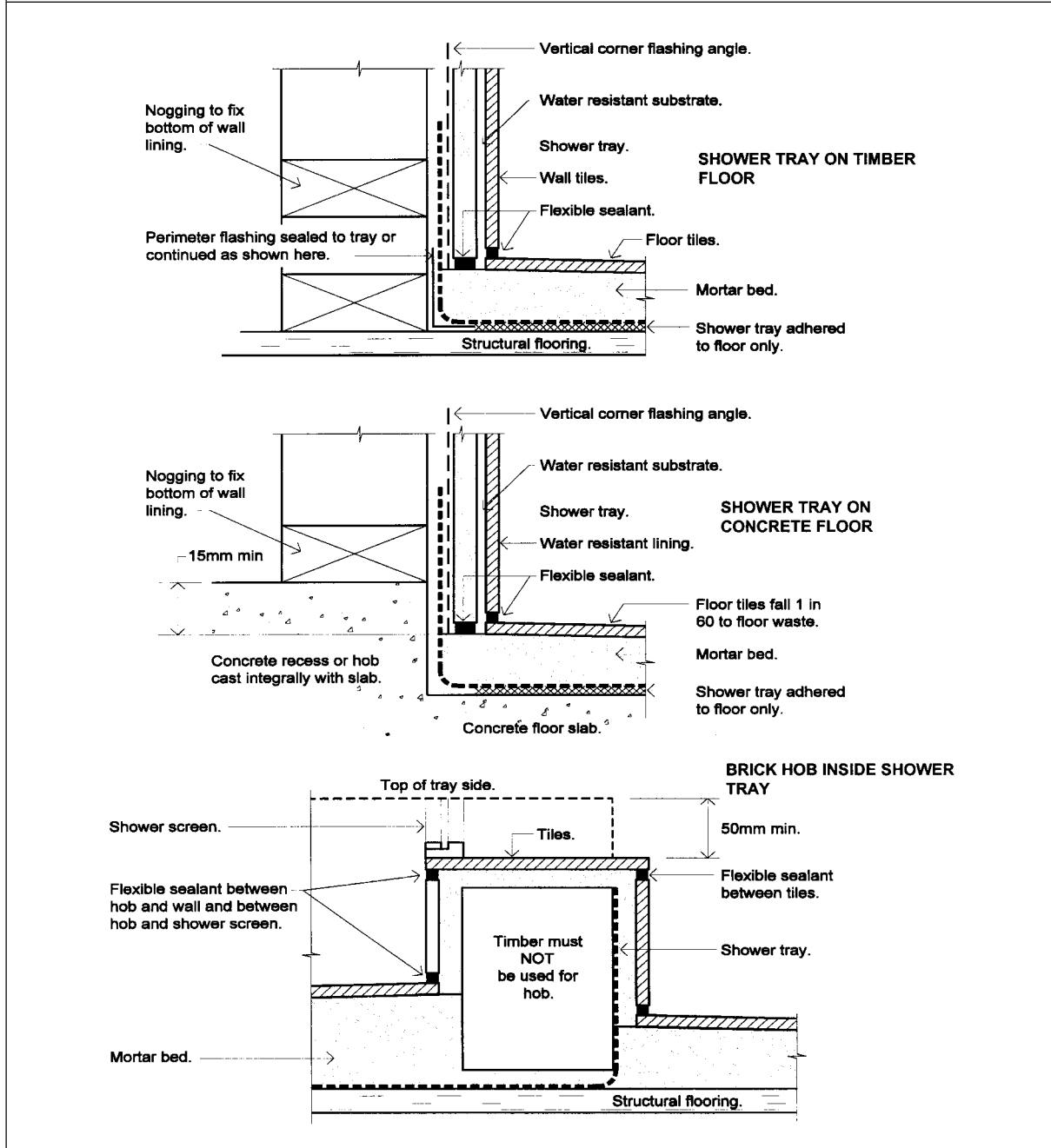

Figure 3.8.1.7
TYPICAL INSTALLATION OF PREFORMED SHOWER TRAYS IN TIMBER FRAMED AND MASONRY WALLS



Amdt 11

Figure 3.8.1.8
FLOORS IN SHOWER AREAS



Amdt 11

Figure 3.8.1.9
TYPICAL INSTALLATION OF WATERPROOF MEMBRANE TO SHOWER FLOOR

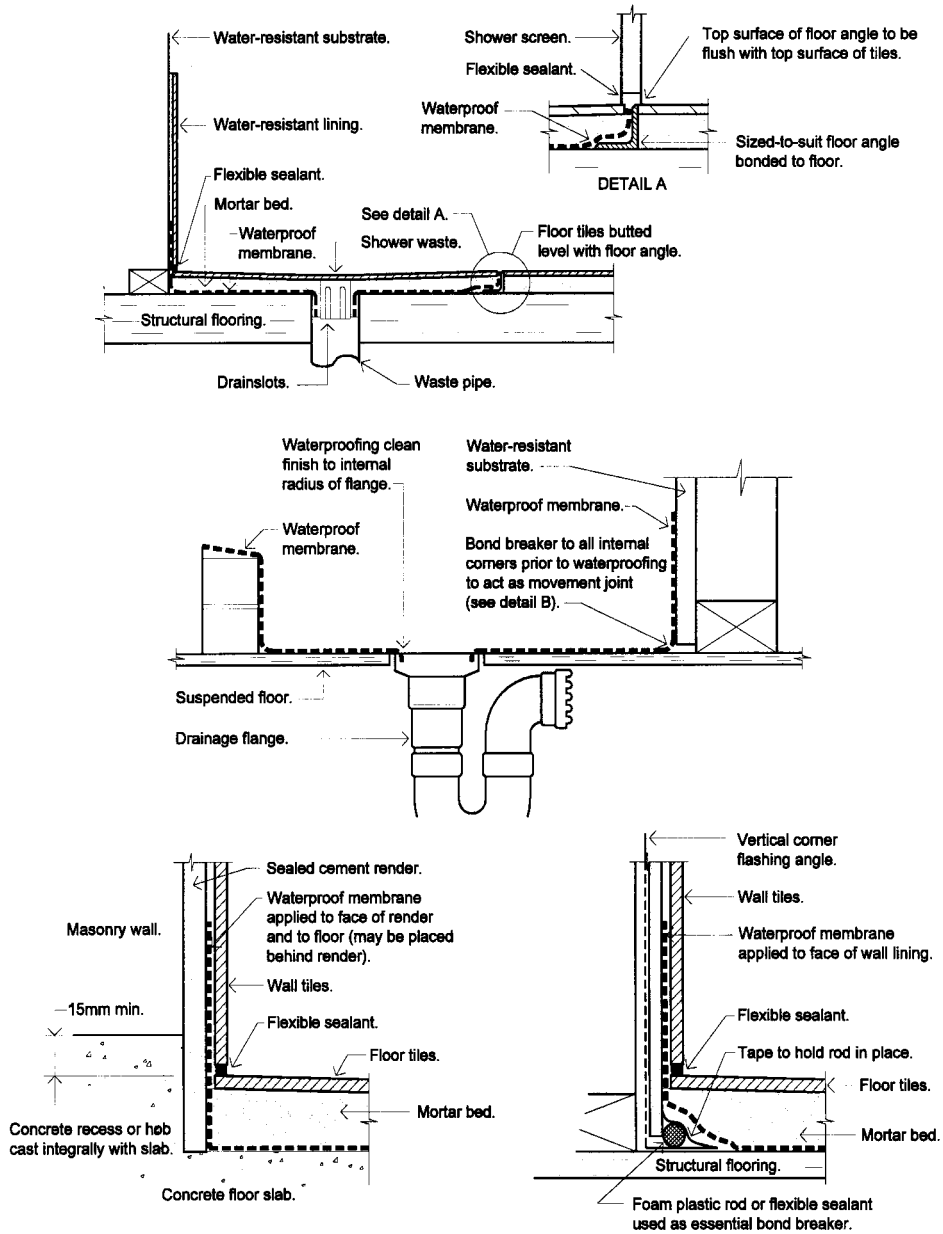

Amdt 11

Figure 3.8.1.10
TYPICAL WALL JUNCTIONS WITH FIXTURES

Diagram a. WALL AND BENCH TOP JUNCTION

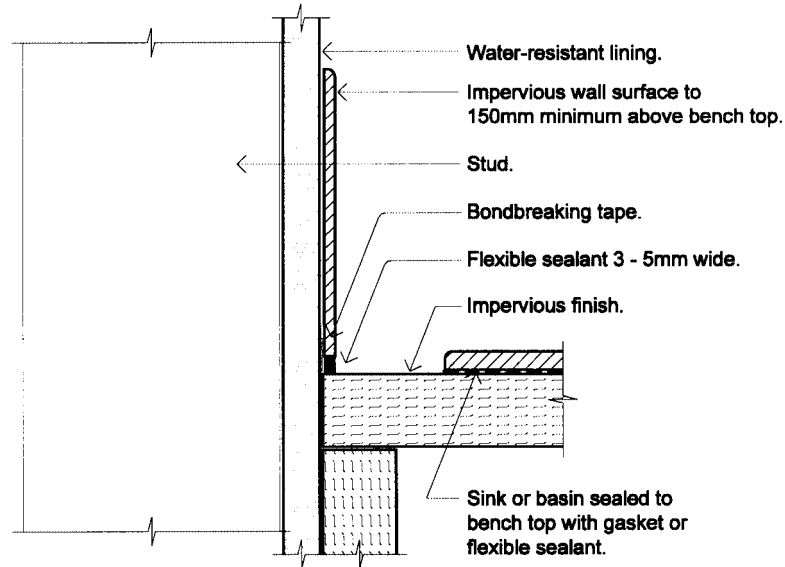
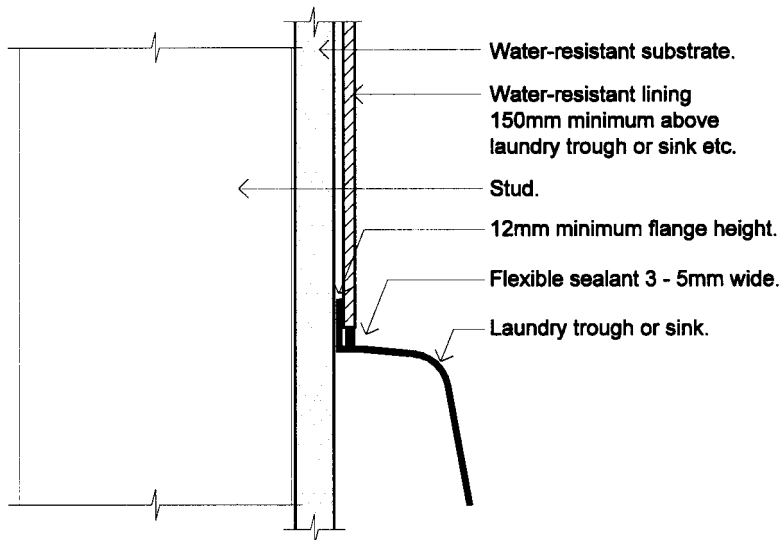

Diagram b. WALL AND LAUNDRY SINK JUNCTION



Amdt 11

Figure 3.8.1.11
TYPICAL WALL AND BATH JUNCTIONS

Diagram a. MASONRY WALL JUNCTION

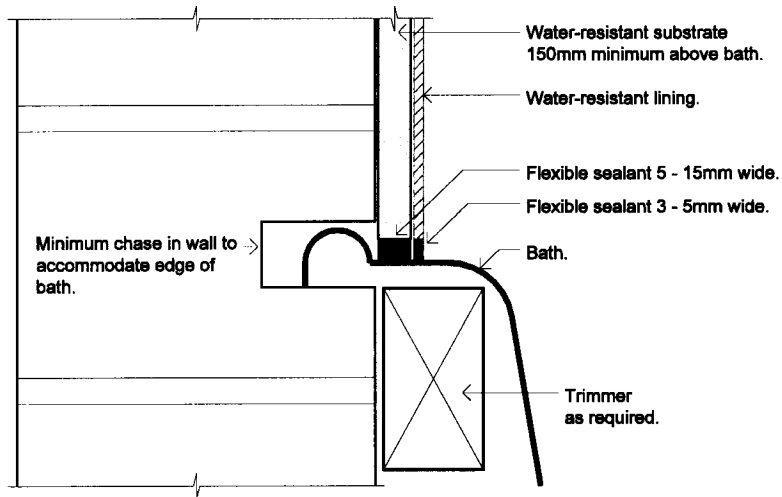
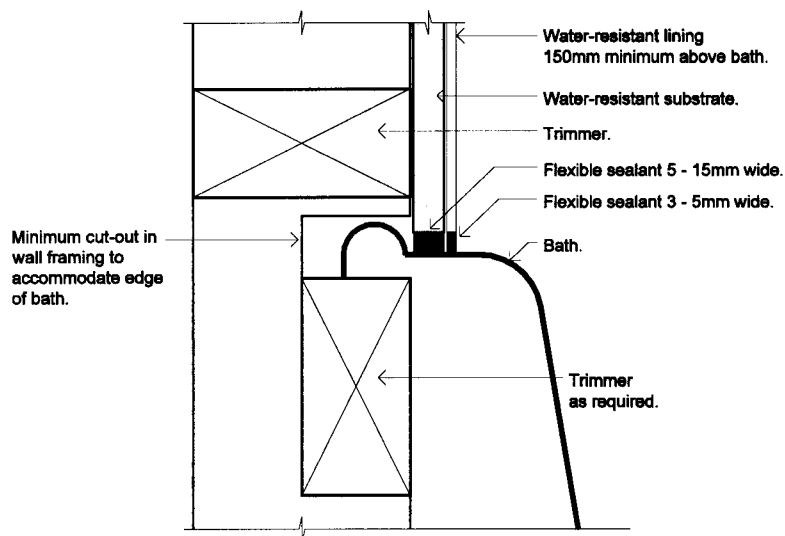

Diagram b. TIMBER WALL JUNCTION



Amdt 11

PART 3.8.2 ROOM HEIGHTS

Appropriate Performance Requirements:

Where an alternative ceiling height is proposed to that described in Part 3.8.2, that proposal must comply with *Performance Requirement P2.4.2* in Section 2.

Acceptable construction practice

3.8.2.1 Application

Compliance with this Part satisfies *Performance Requirement P2.4.2* for room heights.

3.8.2.2 Ceiling heights

Amdt No. 8

Ceiling heights (see Figure 3.8.2.1) must be not less than-

- (a) in a *habitable room* excluding a kitchen - 2.4 m; and
- (b) in a kitchen - 2.1 m; and
- (c) in a corridor, passageway or the like - 2.1 m; and
- (d) in a bathroom, shower room, laundry, *sanitary compartment*, airlock, pantry, storeroom, garage, car parking area or the like - 2.1 m; and
- (e) in an attic room, room with a sloping ceiling or projection below ceiling line or a *non-habitable room* or similar space - a height that does not unduly interfere with the proper functioning of the room or space; and
- (f) in a stairway – 2.0 m measured vertically above the nosing line.

Fig 3.8.2.1
Amdt No. 8

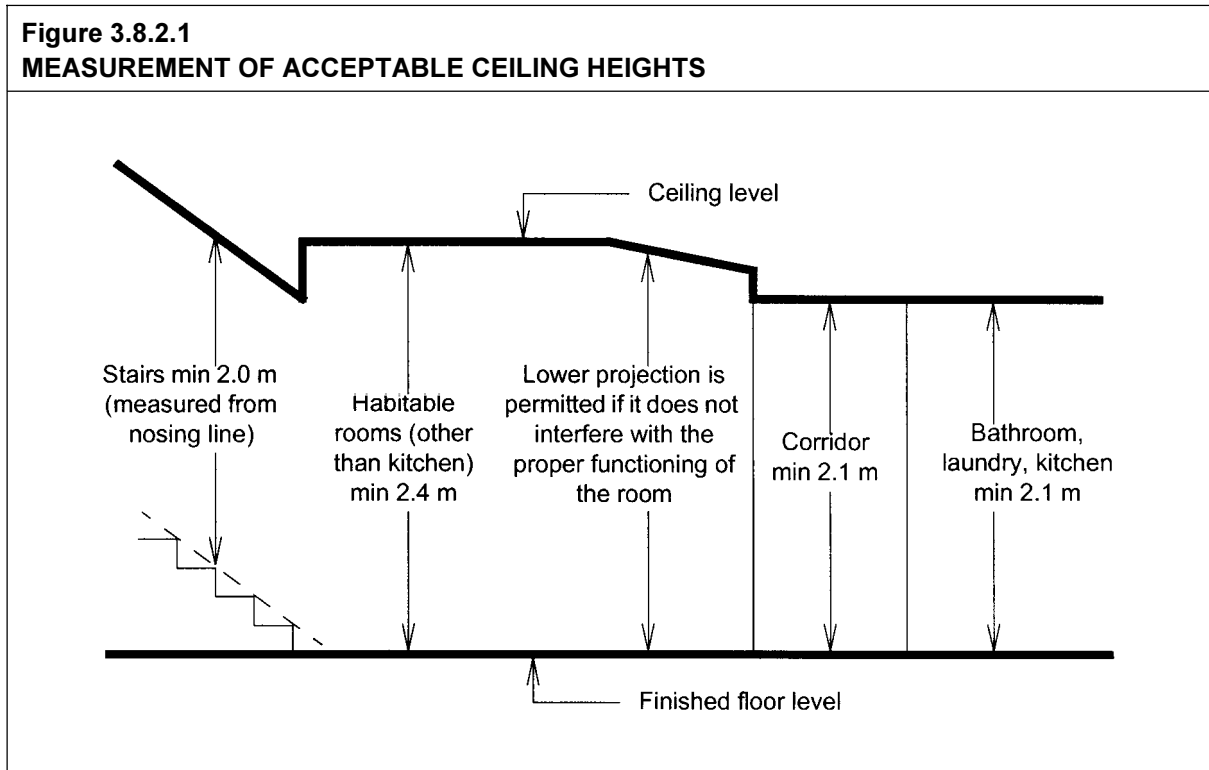

Amdt 11

PART 3.8.3 FACILITIES

Appropriate *Performance Requirements*:

Where an alternative arrangement for facilities is proposed to that described in Part 3.8.3, that proposal must comply with *Performance Requirement* P2.4.3 in Section 2.

Acceptable construction practice

3.8.3.1 Application

Compliance with this Part satisfies *Performance Requirement* P2.4.3 for facilities.

3.8.3.2 Required facilities

- (a) A Class 1 building must be provided with-
 - (i) a kitchen sink and facilities for the preparation and cooking of food; and
 - (ii) a bath or shower; and
 - (iii) clothes washing facilities, comprising at least one washtub and space in the same room for a washing machine; and
 - (iv) a closet pan and washbasin.
- (b) If any of the facilities in (a) are detached from the main building, they must be set aside for the exclusive use of the occupants of the building.

3.8.3.3 Construction of sanitary compartments

Amdt No. 3

The door to a fully enclosed *sanitary compartment* must-

- (a) open outwards; or
- (b) slide; or
- (c) be readily removable from the outside of the compartment,

unless there is a clear space of at least 1.2 m between the closet pan within the *sanitary compartment* and the nearest part of the doorway.

Explanatory information:

3.8.3.3 requires means of removing an unconscious occupant from a fully enclosed sanitary compartment. If the enclosure has gaps that are large enough to allow access for a person into the *sanitary compartment*, the compartment is not considered enclosed for the purpose of this clause.

Amdt 11

Tasmanian
variation
Amdt No. 3

STATE AND TERRITORY VARIATIONS

Part 3.8.3.4 is added as follows in Tasmania.

Installation of closet fixtures

- (a) If a sufficient sewerage system is not available, an authorised alternative means of disposal of sewage, may be installed.
- (b) If sanitary facilities are not water-flushed, the following provisions apply.
 - (i) A pit latrine, an incinerating toilet, a chemical toilet, a removable pan or a non-flushing urinal must not be within 2 m of a building containing habitable rooms.
 - (ii) The floor on which a removable pan is placed must be impervious.
 - (iii) A room containing a composting toilet must be separated from habitable rooms by way of a permanently ventilated air lock (which may be a circulation space).
 - (iv) The minimum ventilation *required* under (iii) shall be the greater of-
 - (A) 8000 mm²; or
 - (B) 1/500th of the *floor area* of the circulation space.
 - (v) Access for maintenance or removal of waste from a composting toilet must be by way of an access door which opens directly to the outside of the building.

Amdt 11

PART 3.8.4 LIGHT

Appropriate Performance Requirements:

Where an alternative lighting system is proposed to that described in Part 3.8.4, that proposal must comply with *Performance Requirement P2.4.4* in Section 2.

Acceptable construction practice

3.8.4.1 Application

Compliance with this Part for a Class 1 building satisfies *Performance Requirement P2.4.4* for lighting.

3.8.4.2 Natural lighting

Natural lighting must be provided in a Class 1 building to all *habitable rooms*, in accordance with the following:

- (a) Natural lighting must be provided by *windows* that-
 - (i) have an aggregate light transmitting area measured exclusive of framing members, glazing bars or other obstructions of not less than 10% of the *floor area* of the room; and
 - (ii) are open to the sky or face a court or other space open to the sky or an open verandah, carport or the like.
- (b) A *window required* to provide natural light that faces a boundary of an adjoining allotment must not be less than a horizontal distance of 900 mm from that boundary.
- (c) Natural lighting to a room in a Class 1 building may come through a glazed panel or opening from an adjoining room (including an enclosed verandah) if-
 - (i) the glazed panel or opening has an area of not less than 10 % of the *floor area* of the room to which it provides light; and
 - (ii) the adjoining room has *windows* with an aggregate light transmitting area of not less than 10 % of the combined *floor areas* of both rooms; and
 - (iii) the areas specified in (i) and (ii) may be reduced as appropriate if direct natural light is provided from another source.

(see Figure 3.8.4.1)

Figure 3.8.4.1

METHOD OF DETERMINING AREAS OF OPENINGS FOR BORROWED LIGHT

$$A = \frac{axb}{10} \text{ m}^2$$

$$B = \frac{axc}{10} \text{ m}^2$$

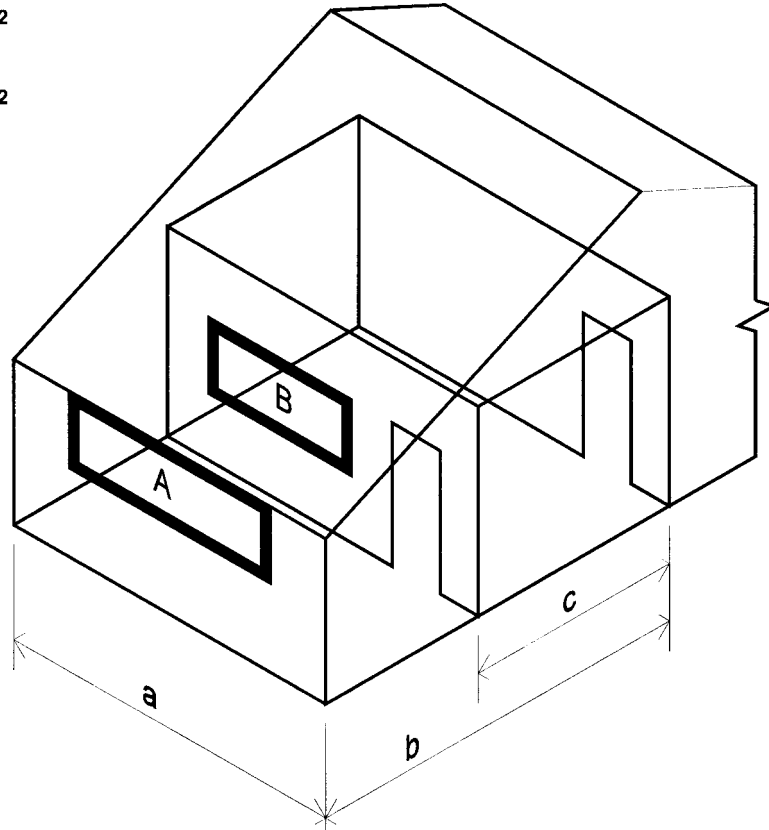

Amdt 11

3.8.4.3 Artificial lighting

Sanitary compartments, bathrooms, shower rooms, airlocks and laundries must be provided with artificial light if natural lighting in accordance with the relevant provisions of 3.8.4.2 is not available-

- (a) at a rate of not less than one light fitting per 16 m² of *floor area*; or
- (b) in accordance with AS 1680.

PART 3.8.5 VENTILATION

Appropriate Performance Requirements:

Where an alternative ventilation system is proposed to that described in Part 3.8.5, that proposal must comply with *Performance Requirement P2.4.5* in Section 2.

A. Acceptable construction manual

3.8.5.0 *Performance Requirement P2.4.5* is satisfied for a mechanical ventilation system if it is installed in accordance with AS 1668.2 - Mechanical ventilation for acceptable indoor air quality, except that any contaminated air from a *sanitary compartment* or bathroom must-

- (a) exhaust directly to outside the building by way of ducts; or
- (b) exhaust into the roof space provided-
 - (i) it is adequately ventilated by open eaves, and/or roof vents; or
 - (ii) the roof is clad in roofing tiles without sarking or similar materials which would prevent venting through gaps between tiles.

B. Acceptable construction practice

3.8.5.1 Application

Compliance with this Part satisfies *Performance Requirement P2.4.5* for ventilation.

3.8.5.2 Ventilation requirements

Ventilation must be provided to a *habitable room*, *sanitary compartment*, bathroom, shower room, laundry and any other room occupied by a person for any purpose by any of the following means:

- (a) Permanent openings, *windows*, doors or other devices which can be opened-
 - (i) with an aggregate opening or openable size not less than 5% of the *floor area* of the room *required* to be ventilated; and
 - (ii) open to-
 - (A) a suitably sized court, or space open to the sky; or
 - (B) an open verandah, carport, or the like; or
 - (C) an adjoining room in accordance with (b).

- (b) Natural ventilation to a room may come through a *window*, opening, ventilating door or other device from an adjoining room (including an enclosed verandah) if-
- (i) the room to be ventilated or the adjoining room is not a *sanitary compartment*; and
 - (ii) the *window*, opening, door or other device has a ventilating area of not less than 5% of the *floor area* of the room to be ventilated; and
 - (iii) the adjoining room has a *window*, opening, door or other device with a ventilating area of not less than 5% of the combined *floor areas* of both rooms; and
 - (iv) the ventilating areas specified may be reduced as appropriate if direct natural ventilation is provided from another source.
- (See Figure 3.8.5.1)

Figure 3.8.5.1

METHOD OF DETERMINING AREAS OF OPENINGS FOR BORROWED VENTILATION

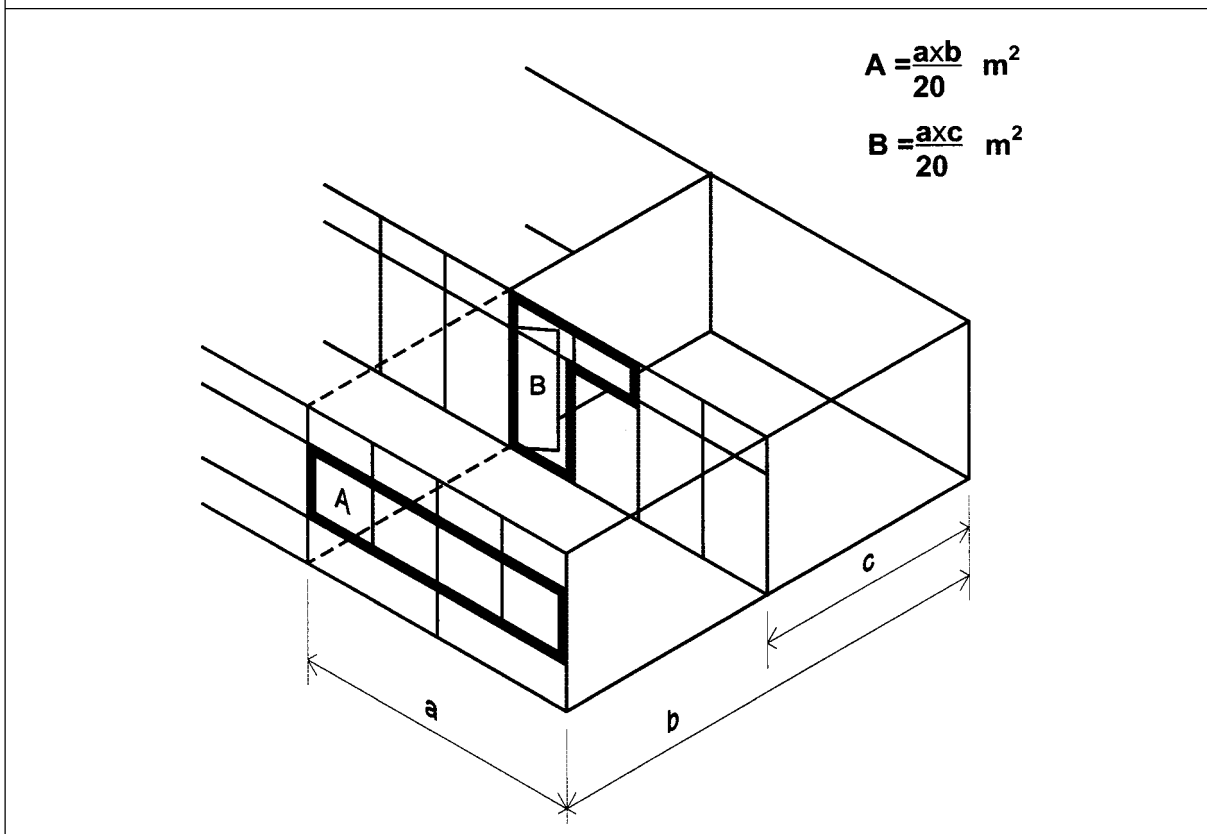

3.8.5.3 Location of sanitary compartments

Sanitary compartments must not open directly into a kitchen or pantry unless-

- (a) access is by an airlock, hallway or other room, (see Figure 3.8.5.2); or
- (b) the room containing the closet pan is provided with mechanical exhaust ventilation installed in accordance with Part 3.8.5.

Figure 3.8.5.2
ACCEPTABLE LOCATION OF NON MECHANICALLY VENTILATED SANITARY COMPARTMENT

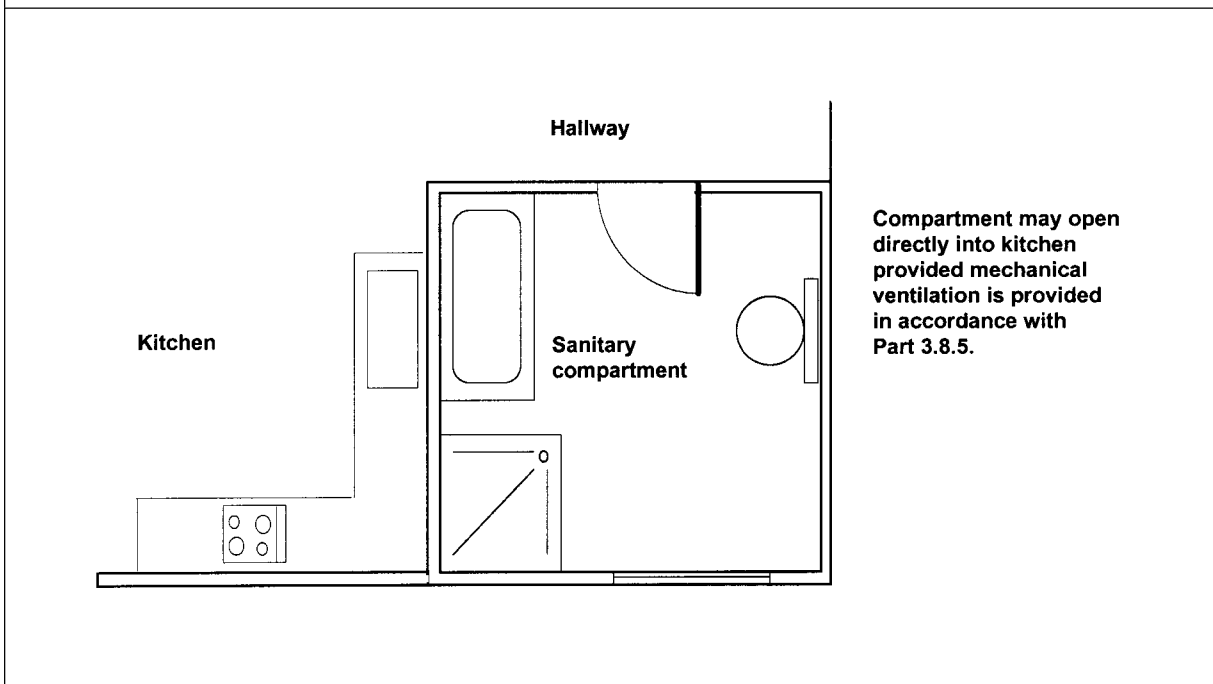

PART 3.8.6 SOUND INSULATION

Appropriate Performance Requirements:

Where an alternative sound insulation system is proposed to that described in Part 3.8.6, that proposal must comply with *Performance Requirement P2.4.6* in Section 2.

Acceptable construction practice

3.8.6.1 Application

Compliance with this Part satisfies *Performance Requirement P2.4.6* for sound insulation.

3.8.6.2 Sound insulation requirements

- Amdt No. 9**
- (a) A *separating wall* between two or more Class 1 buildings must-
 - (i) achieve the weighted sound reduction index (R_w) and impact sound resistance *required* by Table 3.8.6.1; and
 - (ii) be installed in accordance with the appropriate requirements of 3.8.6.3 and 3.8.6.4; and
 - (b) for the purpose of this Part, the R_w may be determined in accordance with AS/NZS 1276.1 or ISO 717.1.

Table 3.8.6.1
Amdt No. 6

Table 3.8.6.1 REQUIRED R_w AND SOUND IMPACT LEVELS FOR SEPARATING WALLS		
SEPARATING WALL - LOCATION AND PENETRATIONS	IMPACT SOUND RESISTANCE (As per Table 3.8.6.2)	R_w (As per Table 3.8.6.3)
TYPE A Between a bathroom, <i>sanitary compartment</i> , laundry or kitchen and a <i>habitable room</i> (other than a kitchen) in an adjoining Class 1 building (dwelling) (see Figure 3.8.6.1).	YES	50
TYPE B In all other cases to those listed as Type A. (See Figure 3.8.6.1)	NO	45
SOIL AND WASTE PIPES A waste pipe or other penetration that serves or passes through a <i>separating wall</i> between houses -		
(a) if the adjacent room is a <i>habitable room</i> (other than a kitchen); or	NO	45
(b) if the room is a kitchen or any other room.	NO	30

Amdt 11

Figure 3.8.6.1
Amdt No. 6

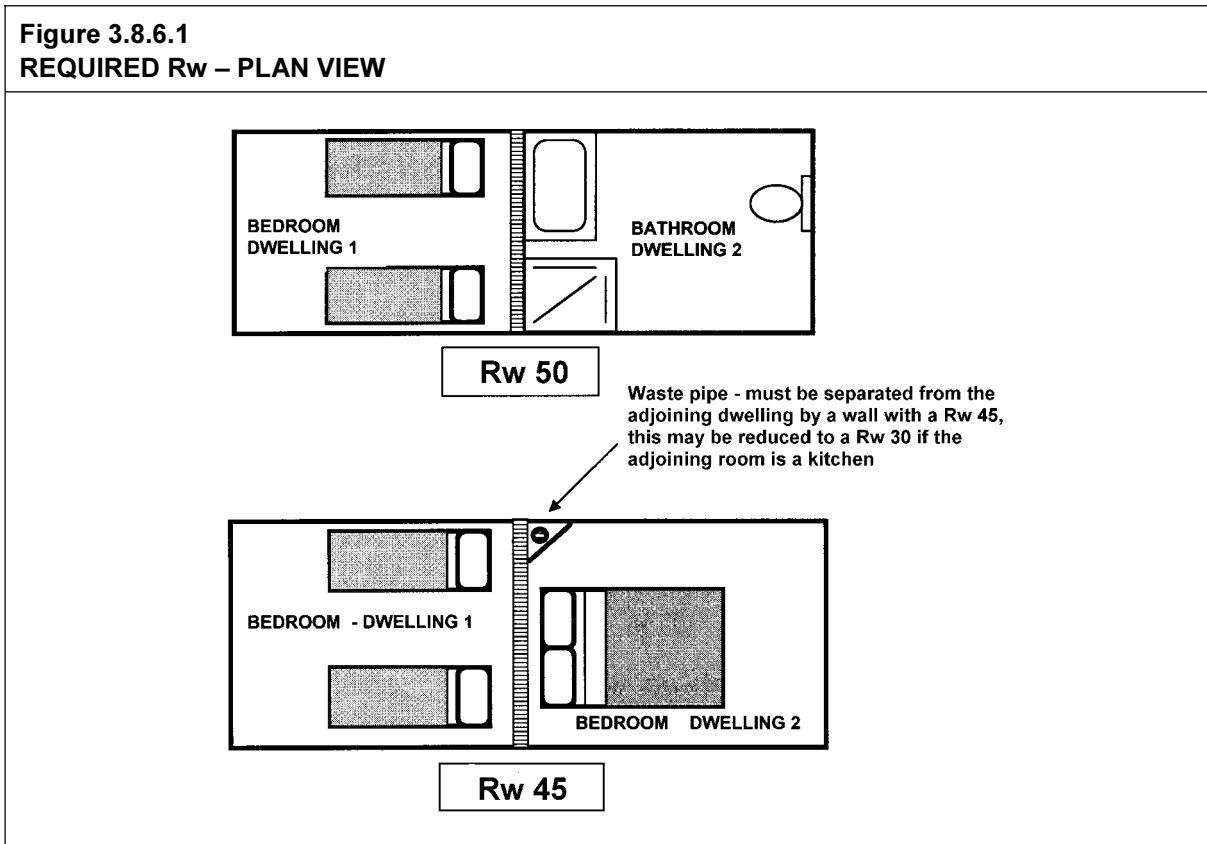

Amdt 11

3.8.6.3 General installation requirements for walls

3.8.6.3(a)
Amdt No. 6

- (a) To achieve the appropriate R_w and impact sound resistance, walls must –
- (i) be installed in accordance with the appropriate requirements contained in (b) to (f); and
 - (ii) at the junction of sound insulated walls with perimeter walls and roof cladding, be sealed in accordance with any relevant detail in Figure 3.8.6.3.
- (b) Masonry units must-
- (i) be laid with all joints filled solid, including those between the masonry and any adjoining construction; and
 - (ii) not be chased for services.
- (c) Joints between concrete slabs, wall units and any adjoining construction must be filled solid.

- (d) Plasterboard must be installed as follows:
- (i) If one layer is *required* under this Part, joints must be staggered with the joints in sheets on the opposite face of the wall.
 - (ii) If 2 layers are *required*, the first layer must be fixed according to (i) and the second layer must be fixed to the first layer with nails, screws or adhesive so that the joints do not coincide with those of the first layer.
 - (iii) Joints between sheets or between sheets and any adjoining construction must be taped and filled solid.
 - (iv) Fire-protective grade plasterboard (when nominated) must be the grade manufactured for use in *fire-resisting* construction.

Figure 3.8.6.2
TYPICAL INSTALLATION OF PLASTER SHEETS FOR SOUND INSULATION

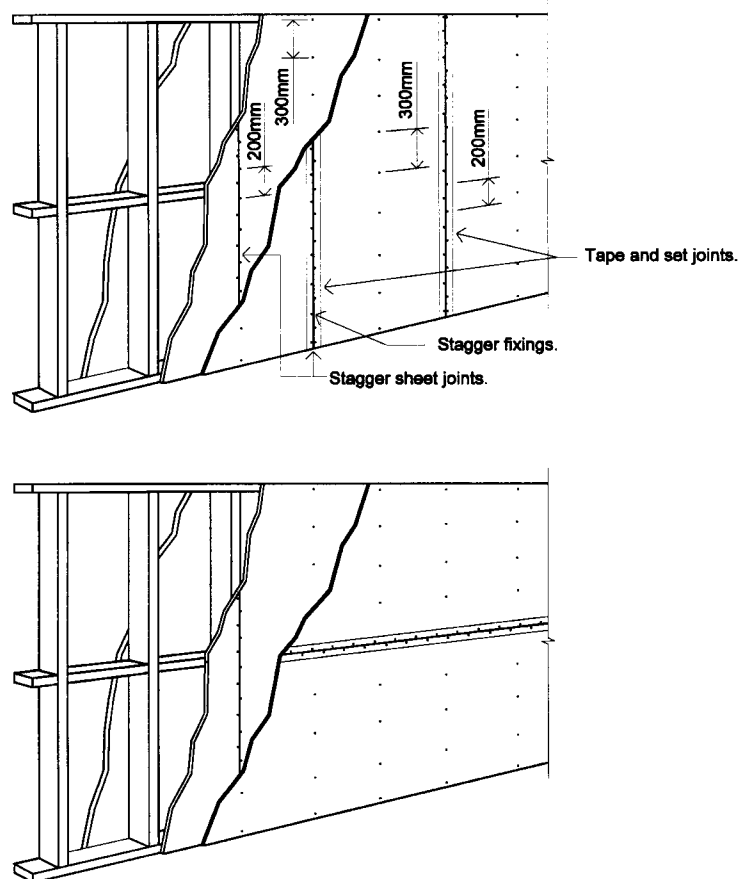

- (e) Steel studs and perimeter members must be installed as follows:
 - (i) The section of steel must be not less than 0.6 mm thick.
 - (ii) Studs must be not less than 63 mm in depth unless another depth is specified in the Table.
 - (iii) Studs must be fixed to steel top and bottom plates of sufficient depth to permit secure fixing of the plasterboard.
 - (iv) All steel members at the perimeter of the wall must be securely fixed to the adjoining structure and bedded in resilient compound or the joints must be caulked so that there are no voids between the steel members and the wall.
- (f) Timber studs and perimeter members must be installed as follows:
 - (i) Studs must be fixed to top and bottom plates of sufficient depth to permit secure fixing of the plasterboard.
 - (ii) Noggings and like members must not bridge between studs supporting different wall leaves.
 - (iii) All timber members at the perimeter of the wall must be securely fixed to the adjoining structure and bedded in resilient compound or the joints must be caulked so there are no voids between the timber members and the wall.

3.8.6.4 Soil and waste pipes

If a soil or waste pipe passes through a *separating wall*-

- (a) a door or panel providing access to the pipe must not open into any *habitable room*, other than a kitchen; and
- (b) an access door or panel in any other part must be firmly fixed so as to overlap the frame or rebate of the frame by not less than 10 mm, be fitted with a sealing gasket along all edges and constructed of-
 - (i) wood, plasterboard or blockboard not less than 38 mm thick; or
 - (ii) compressed fibre reinforced cement sheeting not less than 9 mm thick; or
 - (iii) other suitable material with a mass per unit area not less than 24.4 kg/m².

Expl. Info.
Amdt No. 6

Explanatory information:

The wall configurations shown in Tables 3.8.6.2 and 3.8.6.3 are typical examples. Other proprietary methods are available for meeting the R_w and sound impact levels *required* by Table 3.8.6.1.

Table
3.8.6.2
Amdt No. 6



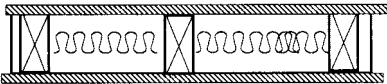
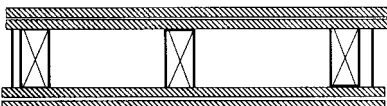

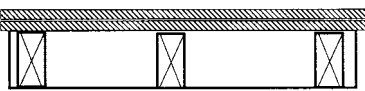

Table 3.8.6.2 CONSTRUCTION OF WALLS TO: (A) REDUCE IMPACT SOUND; AND (B) ACHIEVE A 50 Rw	
WALL CONSTRUCTION TYPE	DESIGN DIAGRAM – PLAN VIEW
<p>CAVITY BRICKWORK</p> <p>2 leaves 90 mm brick masonry with-</p> <ul style="list-style-type: none"> (a) all joints filled solid with mortar; and (b) an air space not less than 40 mm between the leaves; and (c) the leaves connected only by ties in accordance with AS 3700 and wall tie spacing details as set out in Part 3.3. 	
<p>SINGLE LEAF BRICKWORK</p> <p>80 mm thick brick masonry with-</p> <ul style="list-style-type: none"> (a) each face rendered 13 mm thick; and (b) 50x12 mm thick timber battens at not more than 610 mm centres fixed to each face but not recessed into the render; and (c) one layer of 12 mm thick softboard nailed to the battens; and (d) 6 mm thick medium density hardboard adhesive-fixed to the softboard. 	
<p>CONCRETE BLOCKWORK</p> <p>190 mm thick concrete block masonry with-</p> <ul style="list-style-type: none"> (a) each face of the blocks fitted with 50x50 mm timber battens, spaced at not more than 610 mm centres, screw-fixed into resilient plugs with rubber inserts; and (b) the space between the battens completely filled with mineral or glass wool blanket or batts not less than 50 mm thick; and (c) the outer face of the battens finished with plasterboard not less than 10 mm thick. 	
<p>TIMBER FRAMED WALLING</p> <p>70x45 mm F5 staggered timber studs at 600 mm centres both sides on 120x35 mm F5 timber plates with-</p> <ul style="list-style-type: none"> (a) one layer of 16 mm fire protective grade plasterboard on both faces; and (b) 50 mm glass fibre batts. 	
<p>TIMBER FRAMED WALLING</p> <p>70 x 45 mm F5 timber double studs at 450 – 600 mm centres with an air space not less than 20 mm between studs with two layers of 13 mm fire protective grade plasterboard on both faces.</p>	
<p>STEEL STUD WALLING</p> <p>64 mm staggered metal studs (0.75 mm base metal thickness) at 600 mm centres both sides, clipped in 92 mm metal tracks with-</p> <ul style="list-style-type: none"> (a) two layers of 13 mm fire protective grade plasterboard to each side; and (b) 50 mm glasswool cavity batts. 	
<p>STEEL STUD WALLING</p> <p>64 mm double metal studs (0.75 mm base metal thickness) at 600 mm centres with an air space not less than 20 mm between studs, in separate frames with no mechanical links with-</p> <ul style="list-style-type: none"> (a) two layers of 13 mm fire protective grade plasterboard to each side; and (b) 50 mm glasswool cavity batts. 	

Amdt 11

Table
3.8.6.3
Amdt No. 6

Table 3.8.6.3 Rw APPLICABLE TO CONSTRUCTION		
WALL CONSTRUCTION TYPE	Rw	DESIGN DIAGRAM – PLAN VIEW
CLAY BRICKWORK		
(a) 110 mm thick in one or more leaves and with a mass per unit area of not less than 290 kg/m ²	45	
(b) 80 mm thick, pressed brick and rendered 13 mm on one side, the mass per unit area of the unrendered wall being not less than 215 kg/m ²	45	
CALCIUM SILICATE BRICKWORK		
(a) 90 mm thick calcium silicate brick with one layer of 10 mm fire protective grade plasterboard on each side.	45	
(b) 90 mm thick calcium silicate brick with one layer of 10 mm fire protective plasterboard and one layer of fire protective plasterboard on metal furring channels.	45	
CONCRETE BLOCKWORK		
(a) 190 mm solid units (or thicker) Material density 2200 kg/m ³	45	
(b) 110 mm solid units (or thicker) Material density 2200 kg/m ³ Material thickness – 83 mm min. 10 mm plasterboard or 12 mm render on each face.	45	
CONCRETE WALL		
In-situ concrete – 125 mm thick and with a density of not less than 2200 kg/m ³ .	45	

Amdt 11

Table 3.8.6.3 (continued)		
R_w APPLICABLE TO CONSTRUCTION		
WALL CONSTRUCTION TYPE	R_w	DESIGN DIAGRAM – PLAN VIEW
STEEL STUD WALLING		
(a) With 2 layers of 16 mm thick fire-protective grade plasterboard fixed to each face.	45	
(b) With 2 layers of 13 mm plasterboard on both sides of 75 mm studs	45	
TIMBER STUD WALLING		
70 x 45 mm timber studs at 450 – 600 mm centres with (a) one layer of 16 mm fire protective grade plasterboard on one face; and (b) 50 mm glass fibre batts, and (c) one layer of 16 mm fire protective grade plasterboard on metal resilient channel.	49	
70 x 45 mm timber studs at 450 – 600 mm centres with two layers of 16 mm fire protective grade plasterboard on both sides.	46	
DUCTS OR OTHER CONSTRUCTION SEPARATING SOIL AND WASTE PIPES FROM UNITS		
MASONRY-		
Not less than 90 mm thick.	30	
PLASTERBOARD-		
(a) 2 layers of plasterboard each 10 mm thick, fixed to timber studs not less than 75 mm x 50 mm and spaced at not more than 400 mm centres.	30	
(b) 2 layers of plasterboard each 13 mm thick, one on each side of steel studs not less than 50 mm deep and spaced at not more than 400 mm centres.	30	

Amdt 11

Figure 3.8.6.3
SOUND INSULATION BETWEEN UNITS – DOUBLE STUD WALL CONFIGURATION

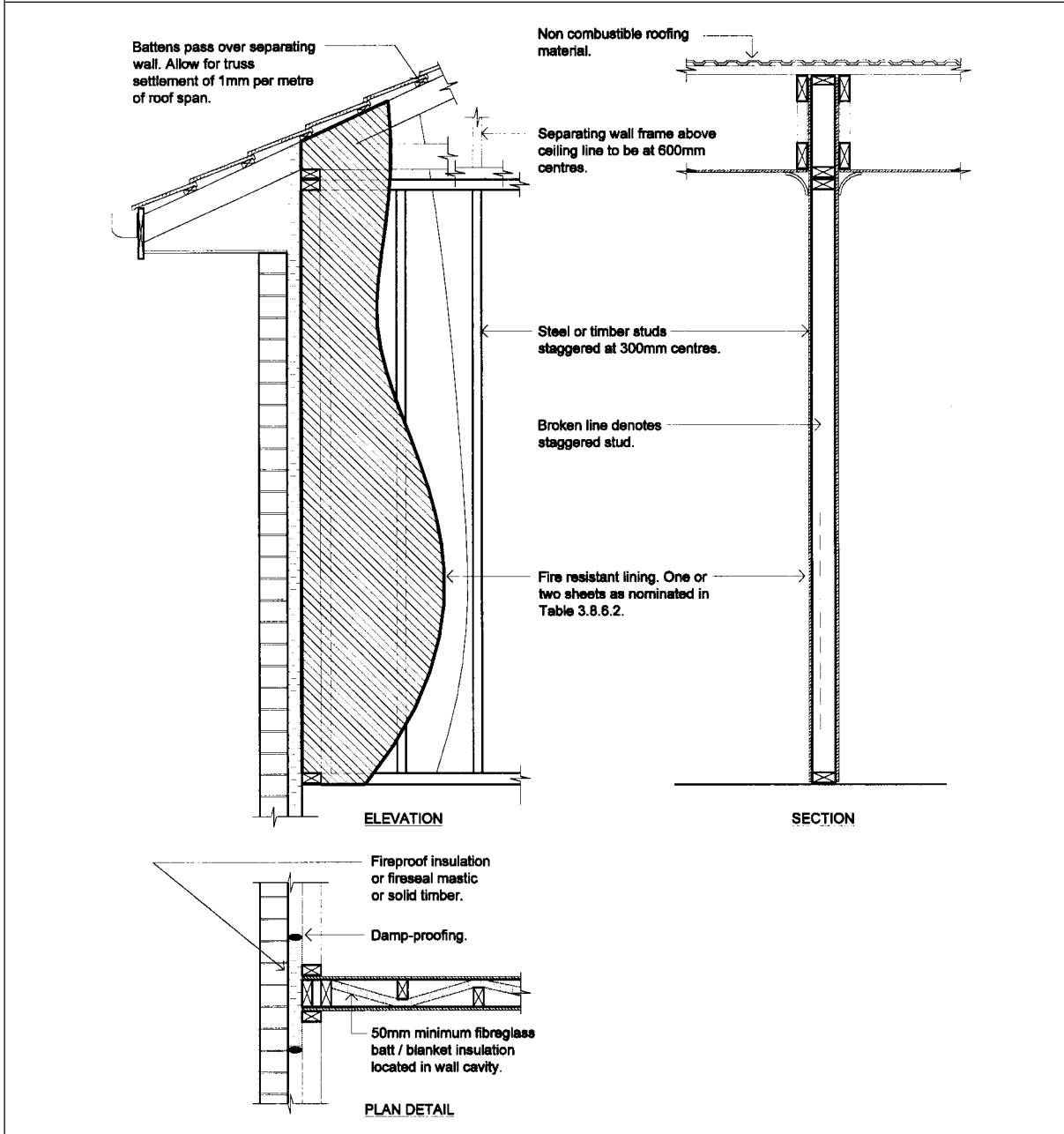

Amdt 11

PART **3.9**

Amdt 11

SAFE MOVEMENT AND ACCESS

- 3.9.1 Stair Construction**
- 3.9.2 Balustrades**
- 3.9.3 Swimming Pool Access**

PART 3.9 SAFE MOVEMENT AND ACCESS

	Page
3.9.1 Stair construction	21,021
3.9.1 Definitions	
3.9.1.1 Application	
3.9.1.2 General requirements	
3.9.1.3 Stair construction	
3.9.1.4 Riser and going dimensions	
3.9.1.5 * * * * *	
3.9.2 Balustrades	21,201
3.9.2.1 Application	
3.9.2.2 When balustrades or other barriers are required	
3.9.2.3 Balustrades or other barrier construction	
3.9.3 Swimming pool access	21,401
3.9.3.0 Acceptable construction manual	
3.9.3.1 Application	
3.9.3.2 Safety fencing location	
3.9.3.3 Safety fencing construction	
3.9.3.4 Gates and fittings	

Amdt 11

PART 3.9.1 STAIR CONSTRUCTION

Appropriate Performance Requirements:

Where an alternative stair system is proposed to that described in Part 3.9.1, that proposal must comply with *Performance Requirement P2.5.1* in Section 2.

Definitions

3.9.1 The following definitions are used in this Part:

3.9.1
Amdt No. 8

Flight means that part of a stair that has a continuous series of *risers*, including *risers* of *winders*, not interrupted by a *landing* or floor (see Figure 3.9.1.1).

Explanatory information:

A *flight* is the area of a stair that has a continuous slope created by the nosing line of treads. The length of a *flight* is limited to restrict the distance a person could fall down a stair. *Quarter landings*, as shown in Figure 3.9.1.1, are considered sufficient to halt a person's fall and therefore are considered for the purposes of this document not to be part of the *flight*.

Fig 3.9.1.1
Amdt No. 8

**Figure 3.9.1.1
IDENTIFICATION OF STAIR FLIGHTS – Plan view**

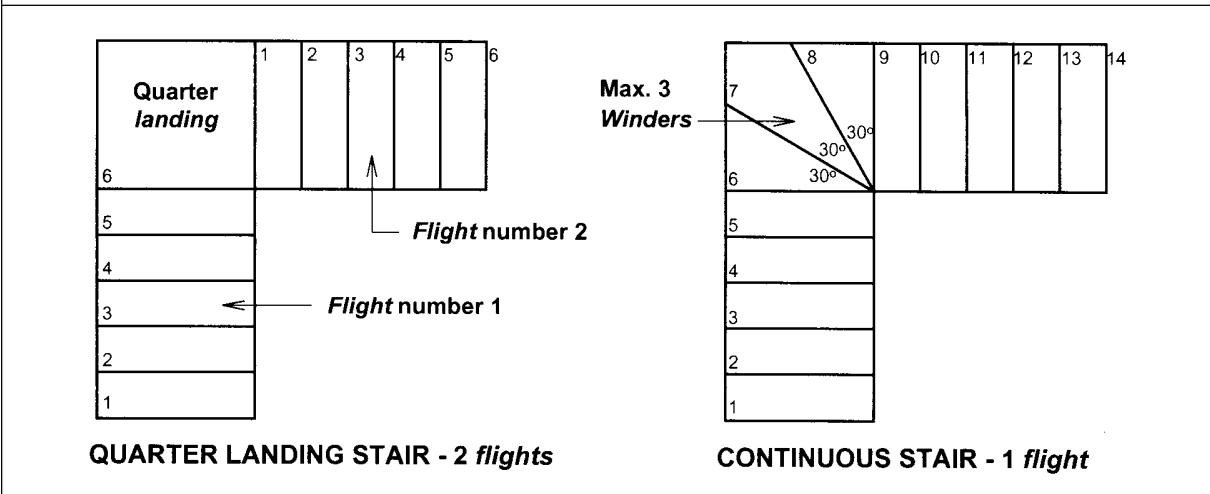

Going means the horizontal dimension from the front to the back of a tread less any overhang from the next tread above (see Figure 3.9.1.2).

Landing means an area at the top or bottom of a *flight* or between two *flights*.

Riser means the height between consecutive treads.

Amdt 11

Spiral stair means a stair with a circular plan, winding around a central post with steps that radiate from a common centre or several radii (see Figure 3.9.1.4).

Tapered tread means a stair tread with a walking area that grows smaller towards one end.

Winders means treads within a straight *flight* that are used to change direction of the stair (see Figure 3.9.1.1).

Acceptable construction practice

3.9.1.1 Application

Compliance with this Part satisfies *Performance Requirement P2.5.1*, provided the stair complies with the appropriate structural requirements of the *Housing Provisions*.

3.9.1.2 General requirements

- (a) Stairs serving *habitable rooms*, including external stairs must comply with 3.9.1.3 and 3.9.1.4.
- (b) Stairs serving only *non-habitable rooms*, such as attics, storerooms and the like that are not used on a regular or daily basis, must be constructed in accordance with-
 - (i) the provisions of this Part; or
 - (ii) AS 1657 - Fixed platforms, walkways, stairways and ladders.

3.9.1.2(b)
Amdt No. 8

3.9.1.3 Stair construction

Amdt No. 8

Stairs must be constructed in accordance with the following:

- (a) Each *flight* must have not more than 18 nor less than 2 *risers*.
- (b) The nominal dimension of *goings* and *risers* of a stair must be constant throughout each stair *flight* except that the *going* of *winders* in lieu of a quarter or half *landing* may vary from the *going* of the straight treads within the same *flight* provided that the *going* of all such *winders* is constant.
- (c) Treads must be of solid construction (not mesh or other perforated material) if the stairway is more than 10 m high or connects more than 3 storeys.
- (d) A *flight* of stairs must not have more than 3 *winders* in lieu of each quarter *landing* or 6 *winders* in lieu of each half *landing*.
- (e) The *riser* opening must not allow a 125 mm sphere to pass through between the treads.
- (f) * * * * *
- (g) Treads must have a non-slip finish or a suitable non-skid strip near the edge of the nosings.

- (h) *Landings* must-
- (i) be not less than 750 mm long and where this involves a change in direction, the length is measured 500 mm from the inside edge of the *landing* (see Figure 3.9.1.5, Diagram a); and
 - (ii) have a gradient not steeper than 1:50; and
 - (iii) be provided where the sill of a threshold of a doorway opens on to a stair that provides a change in floor level or floor to ground level greater than 3 *risers* or 570 mm (see Figure 3.9.1.5, Diagram b).

3.9.1.4 Riser and going dimensions

3.9.1.4
Amdt No. 8

The *riser* and *going* dimensions for each *flight*, except for the *going* of *winders* in lieu of a quarter or half *landing*, must comply with the following:

- (a) The *going* (G), *riser* (R) and slope relationship quantity (2R+G) must be in accordance with Figure 3.9.1.2.
- (b) The point for measurement of the *going* (G) in the slope relationship quantity as described in Figure 3.9.1.3 must be-
 - (i) for *tapered treads* (other than treads in a *spiral stair*)-
 - (A) not more than 1 m wide, the middle of the unobstructed width of the stair (see Figure 3.9.1.3, Diagram b) and
 - (B) more than 1 m in width, 400 mm from the unobstructed width of each side of the stair (see Figure 3.9.1.3, Diagram c); and
 - (ii) for treads in *spiral stairs*, the point seven tenths of the unobstructed distance from the face of the centre pole or support towards the handrail side (see Figure 3.9.1.4).

Figure 3.9.1.2
STAIR RISER AND GOING DIMENSIONS (mm)

STAIR TYPE	RISER (R) (see Figure below)		GOING (G) (see Figure below)		SLOPE RELATIONSHIP (2R+G)	
	Max	Min	Max	Min	Max	Min
Stairs (other than spiral)	190	115	355	240	700	550
Spiral	220	140	370	210	680	590

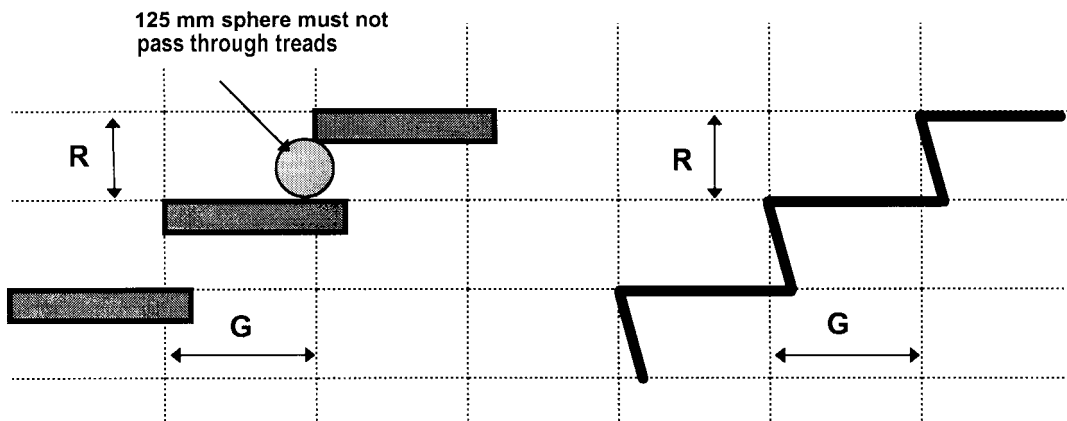

Amdt 11

Fig 3.9.1.3
Amdt No. 7

Figure 3.9.1.3
MEASUREMENT OF SLOPE RELATIONSHIP – Plan view

Diagram a. Stair with 2 flights

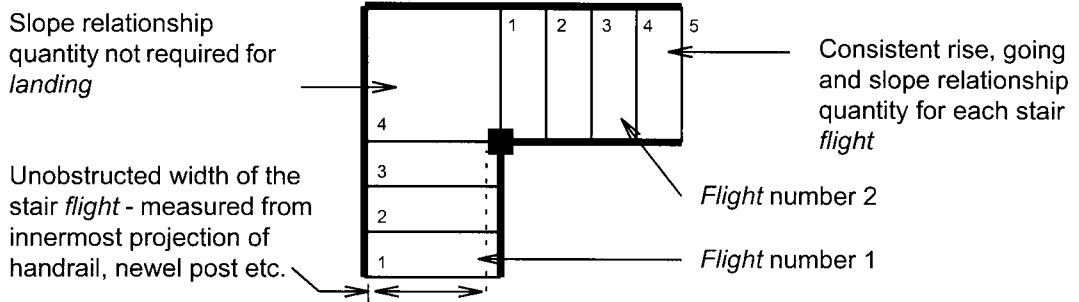

Diagram b. Tapered treads – less than 1 m wide

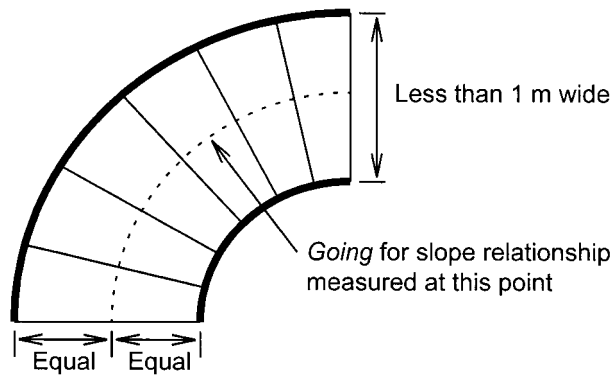
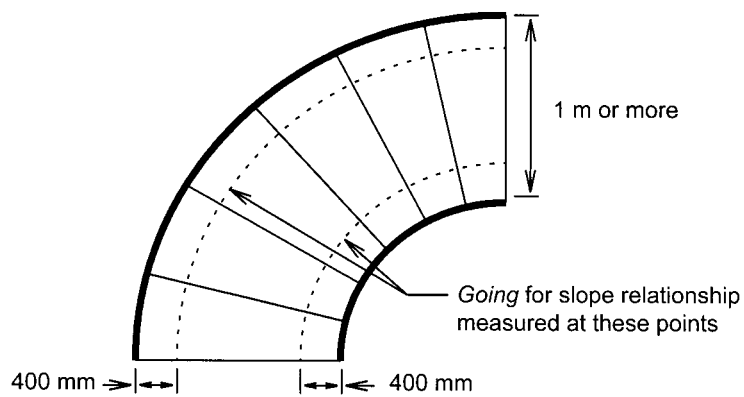

Diagram c. Tapered treads – 1 m or more in width



Amdt 11

Fig 3.9.1.4
Amdt No. 8

**Figure 3.9.1.4
SPIRAL STAIRS**

Diagram a. Measurement for slope relationship

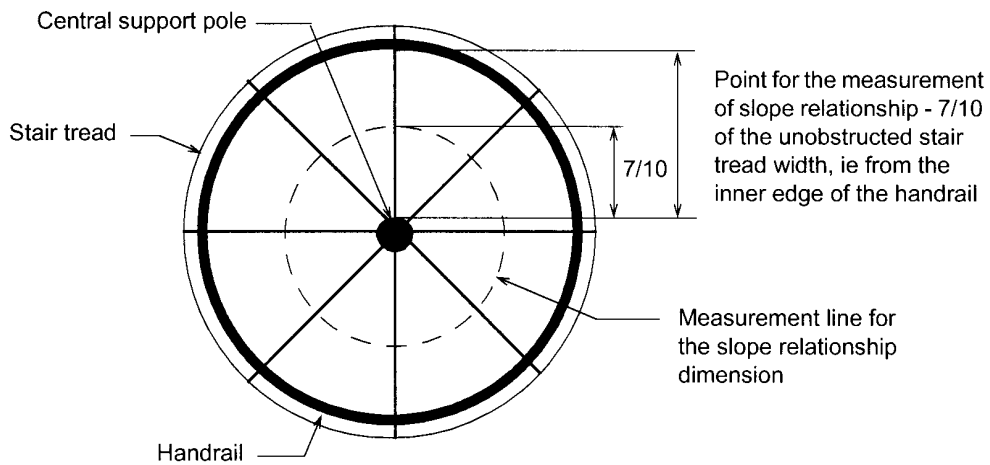
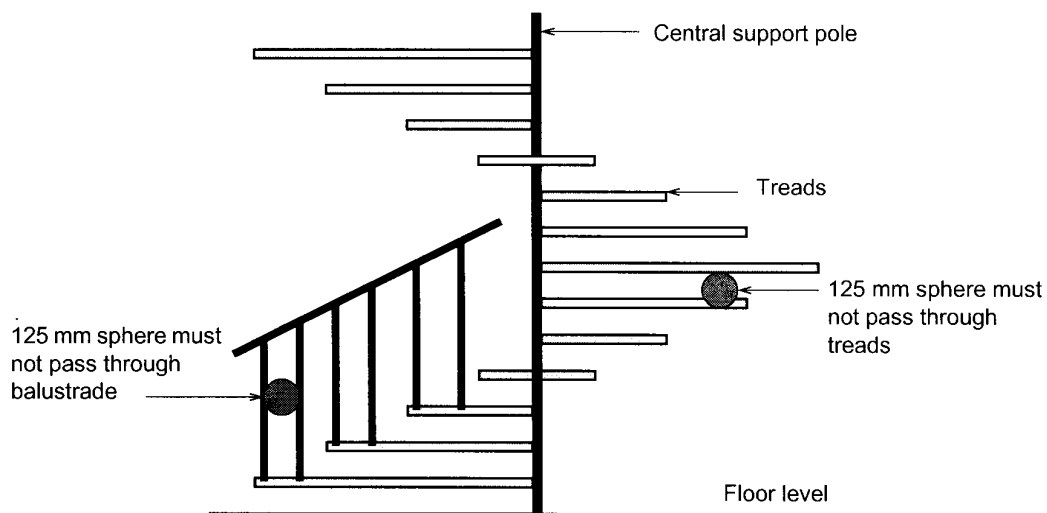

Diagram b. Measurement for openings in stairs



Amdt 11

Fig 3.9.1.5
Amdt No. 8

Figure 3.9.1.5

LANDINGS

Diagram a.

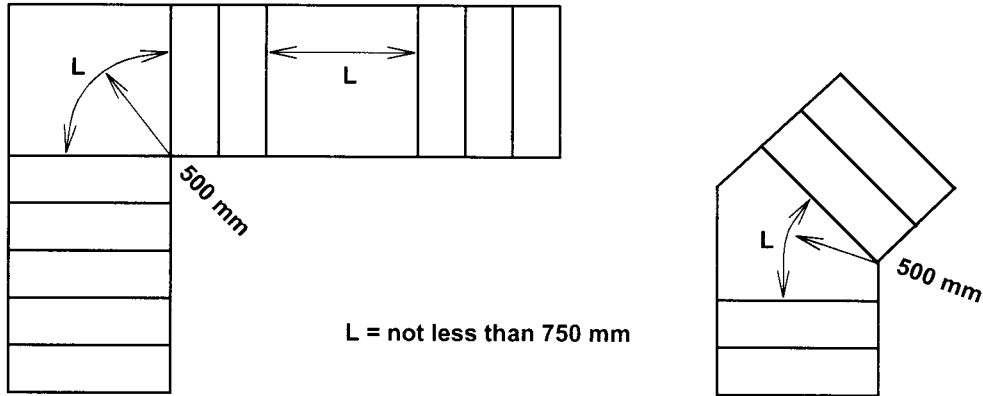
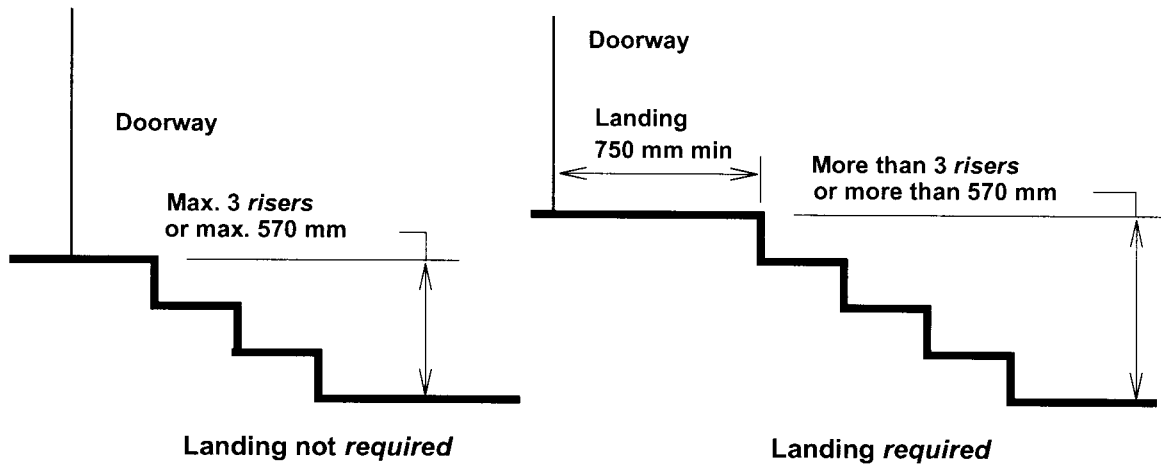

Diagram b.



3.9.1.5

3.9.1.5
Amdt No. 8

* * * * *

Amdt 11

PART 3.9.2 BALUSTRADES

Appropriate Performance Requirements:

Where an alternative balustrade or other barrier is proposed to that described in Part 3.9.2, that proposal must comply with the following *Performance Requirements* P2.1 and P2.5.2 in Section 2:

Acceptable construction practice

3.9.2.1 Application

3.9.2.1
Amdt No. 3

Compliance with this Part satisfies *Performance Requirement* P2.5.2 for balustrades or other barriers.

3.9.2.2 When balustrades or other barriers are required

3.9.2.2
Amdt No. 9

- (a) A continuous balustrade or other barrier must be provided along the side of any roof to which public access is provided, any stairway or ramp, any floor, corridor, hallway, balcony, verandah, mezzanine, access bridge or the like and along the side of any path of access to a building, if-
- (i) it is not bounded by a wall; and
 - (ii) any level is more than 1 m above the surface beneath (see Figure 3.9.2.3).
- (b) The requirements of (a) do not apply to a *window* opening.

3.9.2.3 Balustrades or other barrier construction

3.9.2.3
Amdt No. 11

- (a) The height of a balustrade or other barrier must be in accordance with the following:
- (i) The height must not be less than 865 mm above the nosings of the stair treads or the floor of a ramp.
 - (ii) The height must not be less than-
 - (A) 1 m above the floor of any access path, balcony, *landing* or the like (see Figure 3.9.2.1); or
 - (B) 865 mm above the floor of a *landing* to a stair or ramp where the balustrade or other barrier is provided along the inside edge of the *landing* and is not more than 500 mm long.
- (b) A transition zone may be incorporated where the balustrade or other barrier height changes from 865 mm on the stair *flight* or ramp to 1 m at the *landing* (see Figure 3.9.2.2).

Amdt 11

- (c) Openings in balustrades (including decorative balustrades) or other barriers must be constructed so that any opening does not permit a 125 mm sphere to pass through it and for stairs, the space is tested above the nosing line.
- (d) A balustrade or other barrier must be designed to take loading forces in accordance with AS/NZS 1170.1.
- (e) For floors more than 4 m above the surface beneath, any horizontal elements within the balustrade or other barrier between 150 mm and 760 mm above the floor must not facilitate climbing.

Figure 3.9.2.1
Amdt No. 5

**Figure 3.9.2.1
BALUSTRADE OR OTHER BARRIER CONSTRUCTION**

Note: For the purposes of this Figure, a 125 mm sphere must not pass between rails or through the gap when tested above the nosing line.

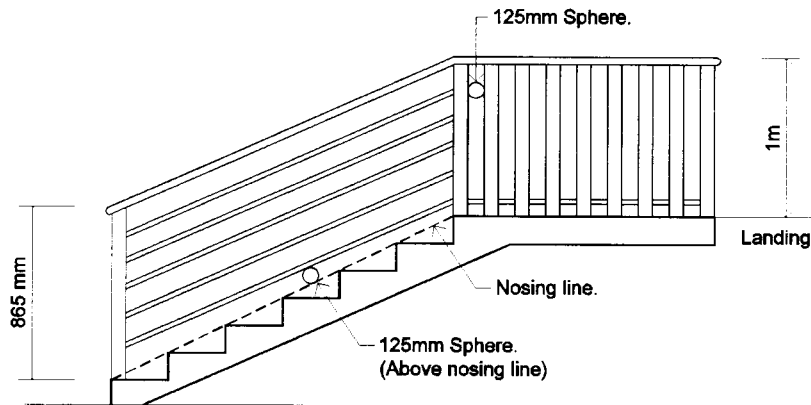

Amdt 11

Figure 3.9.2.2
Amdt No. 5

**Figure 3.9.2.2
TRANSITION ZONES**

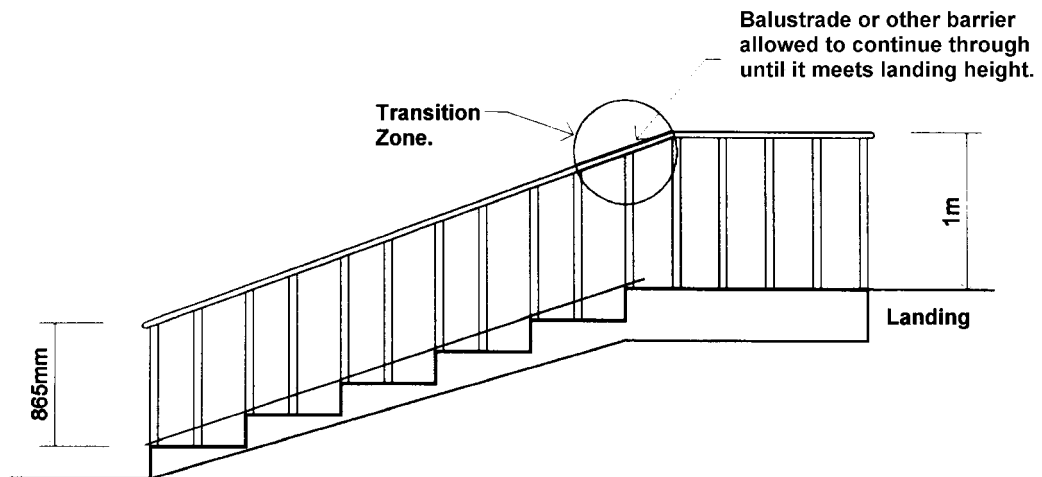
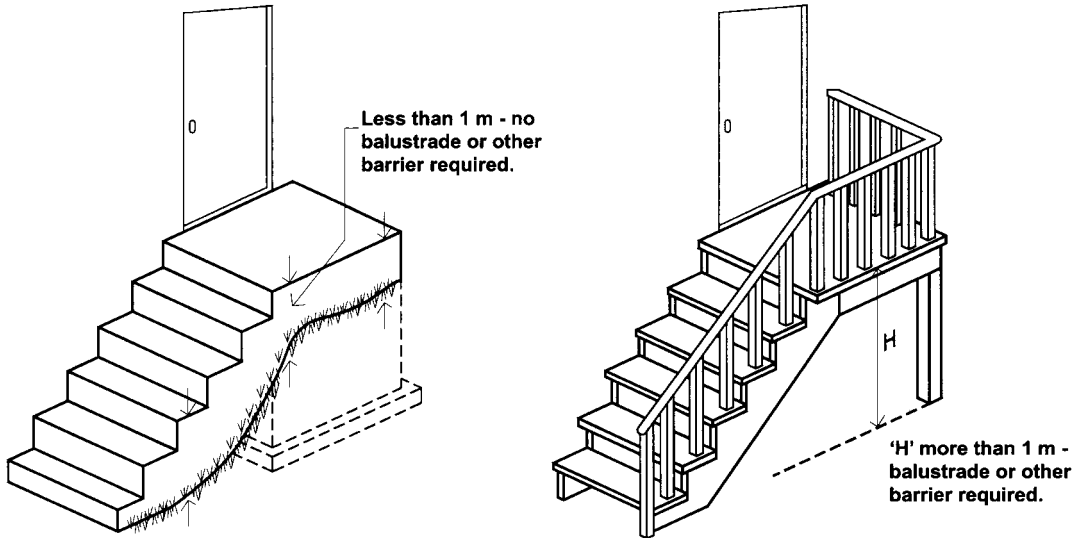

Figure
3.9.2.3
Amdt No. 5

Figure 3.9.2.3
BALUSTRADES OR OTHER BARRIERS – WHEN REQUIRED



Amdt 11

PART 3.9.3 SWIMMING POOL ACCESS

Appropriate Performance Requirements:

Where an alternative *swimming pool* safety fence is proposed to that described in Part 3.9.3, that proposal must comply with the *Performance Requirement P2.5.3* in Section 2.

STATE AND TERRITORY VARIATIONS

NSW var
Amdt No. 11

1. **Part 3.9.3 does not apply in New South Wales.**
Notes: 1. Restriction of access to *swimming pools* in New South Wales is regulated under the *Swimming Pools Act 1992*.
 2. See NSW 1 for additional requirements for *swimming pool* construction.
2. **Part 3.9.3 does not apply in Queensland.**
Note: Restriction of access to *swimming pools* in Queensland is regulated under the *Building Act 1975*.
3. **Part 3.9.3 does not apply in Western Australia.**
Note: Restriction of access to private *swimming pools* in Western Australia is regulated under the *Local Government (Miscellaneous Provisions) Act 1960* and the *Building Regulations 1989* as amended.
4. **Part 3.9.3 does not apply in the Northern Territory.**

Amdt 11

A. Acceptable construction manual

3.9.3.0 *Performance Requirement P2.5.3* is satisfied for a *swimming pool* associated with a Class 1 building, with a depth of water more than 300 mm if it has safety fencing installed in accordance with AS 1926.1 - *Swimming pool safety*.

B. Acceptable construction practice

3.9.3.1 Application

Compliance with this Part satisfies *Performance Requirement P2.5.3* for *swimming pools* with a depth of water more than 300 mm, installed on allotments associated with Class 1 buildings.

3.9.3.2 Safety fencing location

- 3.9.3.2**
Amdt No. 5
- (a) Safety fencing must be located in accordance with one of the options shown in Figure 3.9.3.1.
 - (b) The location of safety fencing must ensure that the effective fencing height is not reduced by nearby objects or projections (see Figure 3.9.3.4).

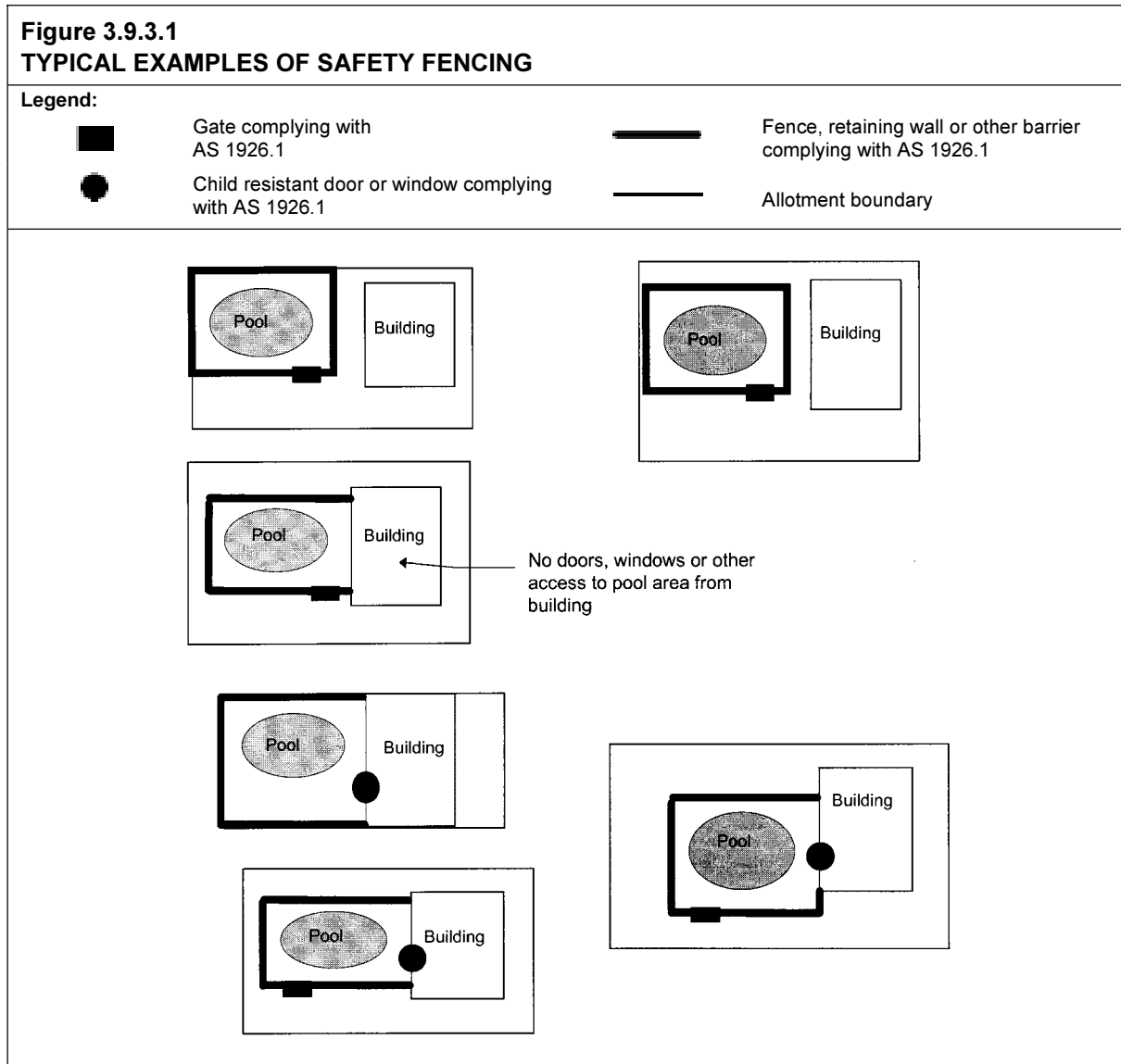

Amdt 11

3.9.3.3 Safety fencing construction

- 3.9.3.3**
Amdt No. 5
- Safety fences and gates must comply with the following:
- (a) The strength and rigidity of fencing components and elements must comply with AS 1926.1.

- (b) The effective height of fencing must be not less than 1.2 m, except for fencing constructed of perforated or mesh material with apertures more than 13 mm but less than 100 mm, in which case the effective height must be not less than that shown in Figure 3.9.3.3.
- (c) Retaining walls or other similar barriers which form part of the safety fencing must comply with Figure 3.9.3.5.
- (d) The clearance between the bottom of the fencing and the finished ground level must not be more than 100 mm.
- (e) Projections or indentations on the outside surface of the fencing must not exceed the dimensions shown in Figure 3.9.3.2(a).
- (f) Horizontal or near horizontal fencing components, such as rails, rods, wires or bracing, that could be used as holds for climbing must-
 - (i) if located on the outside of the fencing; or
 - (ii) if located on the inside of the fencing and the vertical members are spaced more than 10 mm apart;
 be spaced in accordance with Figure 3.9.3.2.
- (g) The clear gap between adjacent vertical or near vertical members must not be more than 100 mm.

Figure 3.9.3.2
SPACING OF ACCESSIBLE HORIZONTAL MEMBERS, PROJECTIONS OR INDENTATIONS IN FENCING

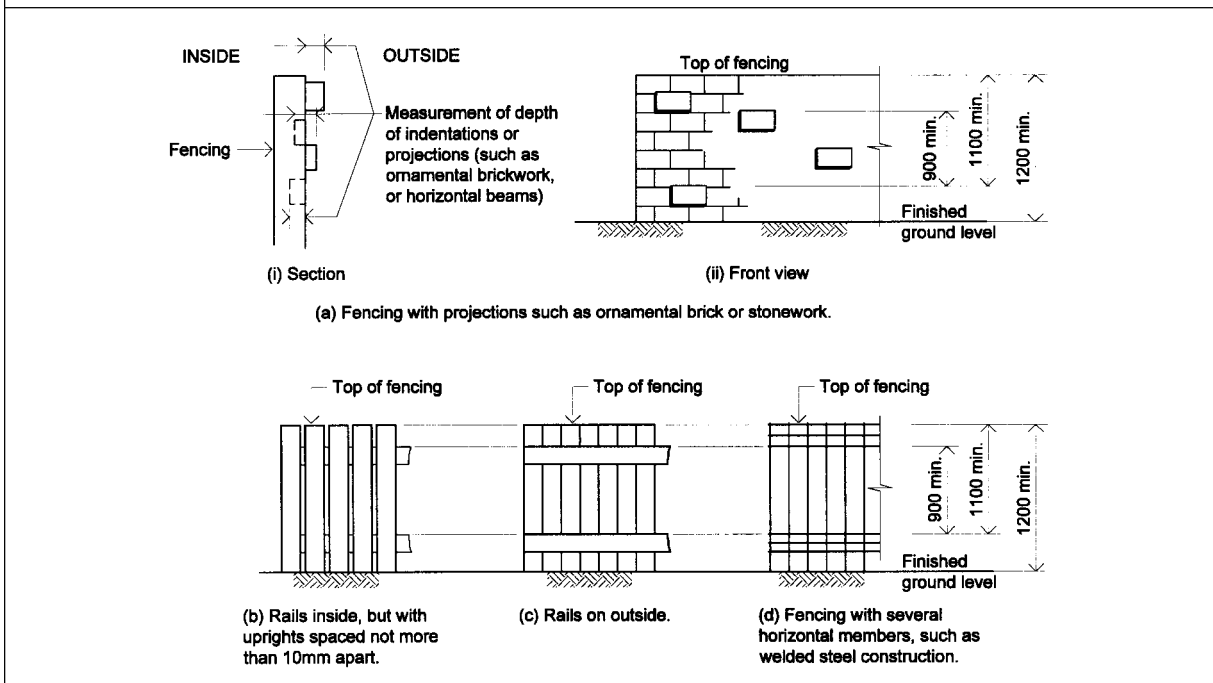
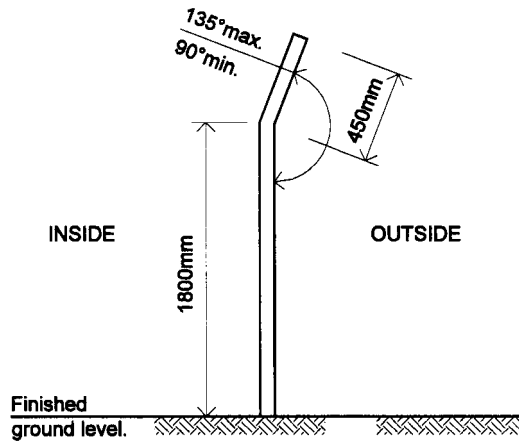

Figure 3.9.3.3
CHAIN WIRE OR MESH FENCE

Note: Fencing material with an aperture more than 13 mm, but less than 100 mm.



Amdt 11

Figure 3.9.3.4
EFFECTIVE FENCING HEIGHT

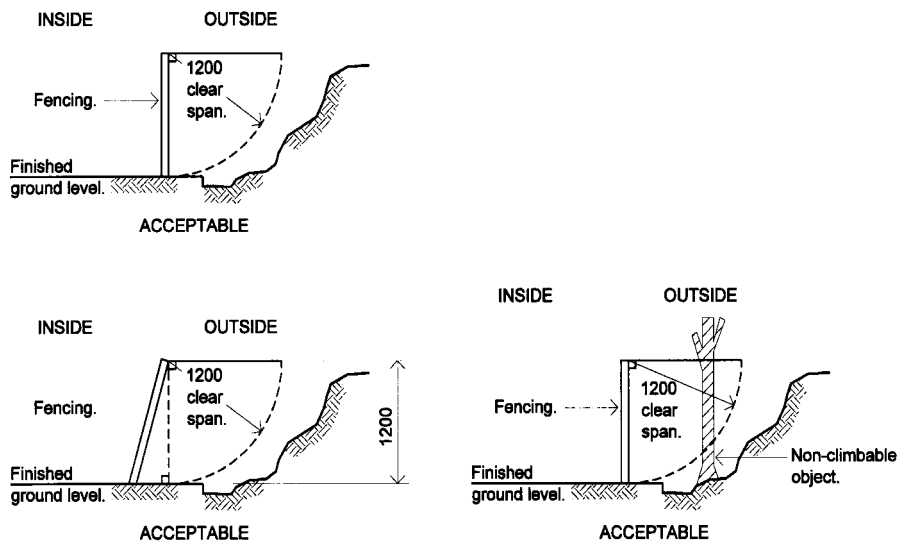
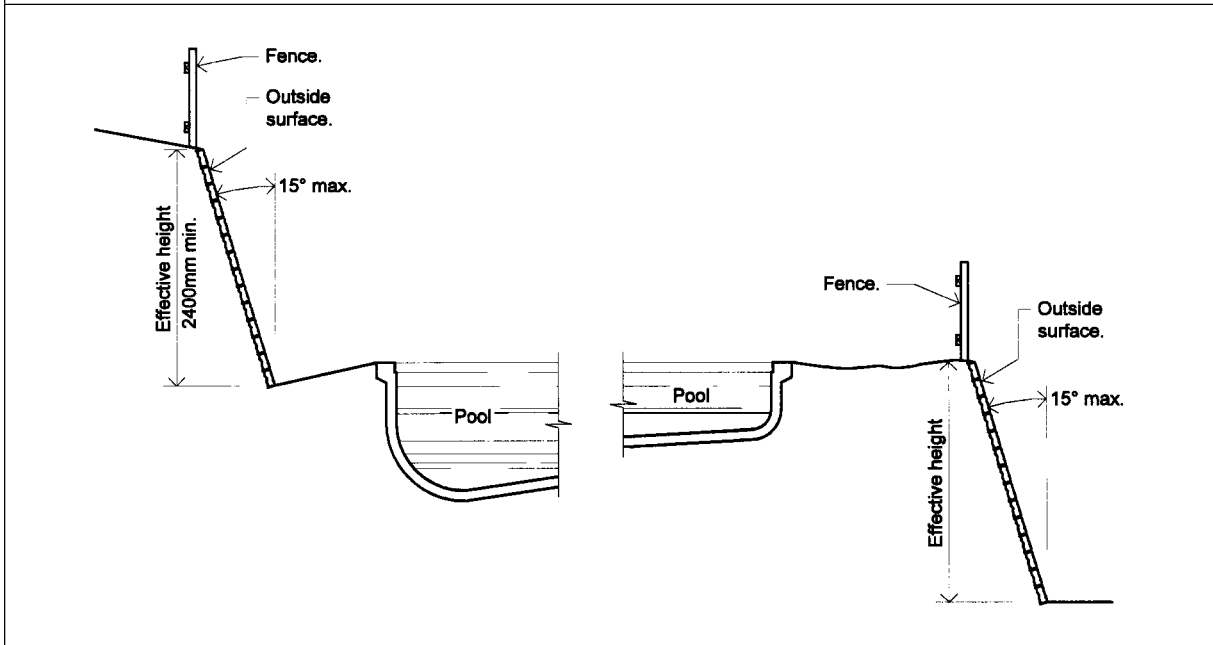

Figure 3.9.3.5
RETAINING WALLS AND OTHER SUCH BARRIERS



Amdt 11

3.9.3.4 Gates and fittings

3.9.3.4
Amdt No. 5

Gates and fittings must comply with the relevant requirements of 3.9.3.2 and the following:

- (a) Gates must swing outwards from the pool area.
- (b) Gates must be fitted with a self closing device that will return the gate to the closed position and operate the latching device-
 - (i) from any position from resting on the latching mechanism to fully open; and
 - (ii) from a stationary start without the application of a manual force.

3.9.3.4(c)
Amdt No. 7

- (c) Gates must be fitted with a latching device-
 - (i) that will automatically operate on the closing of the gate and prevent the gate from being re-opened without manual release; and
 - (ii) that cannot be inadvertently adjusted in operation or adjusted without the use of tools; and
 - (iii) located and shielded in accordance with one of the options shown in Figure 3.9.3.7.

Figure 3.9.3.6
Amdt No. 5

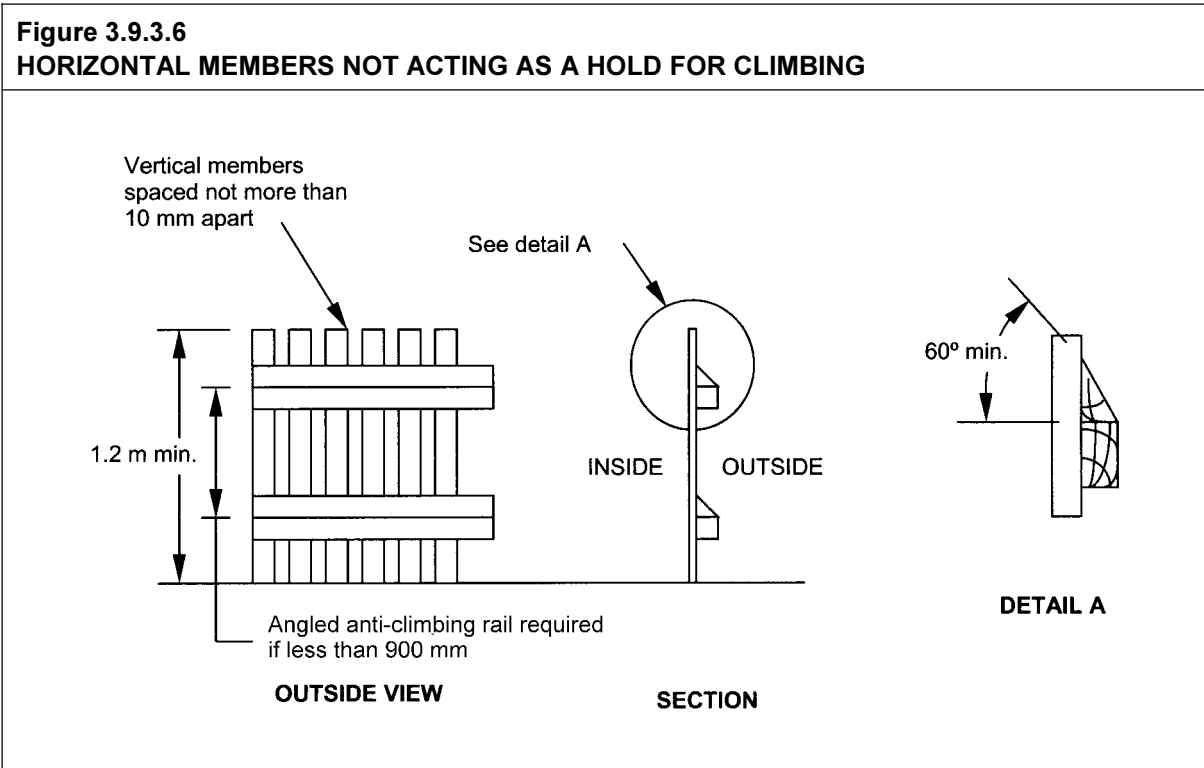

Amdt 11

Figure 3.9.3.7
Amdt No. 5

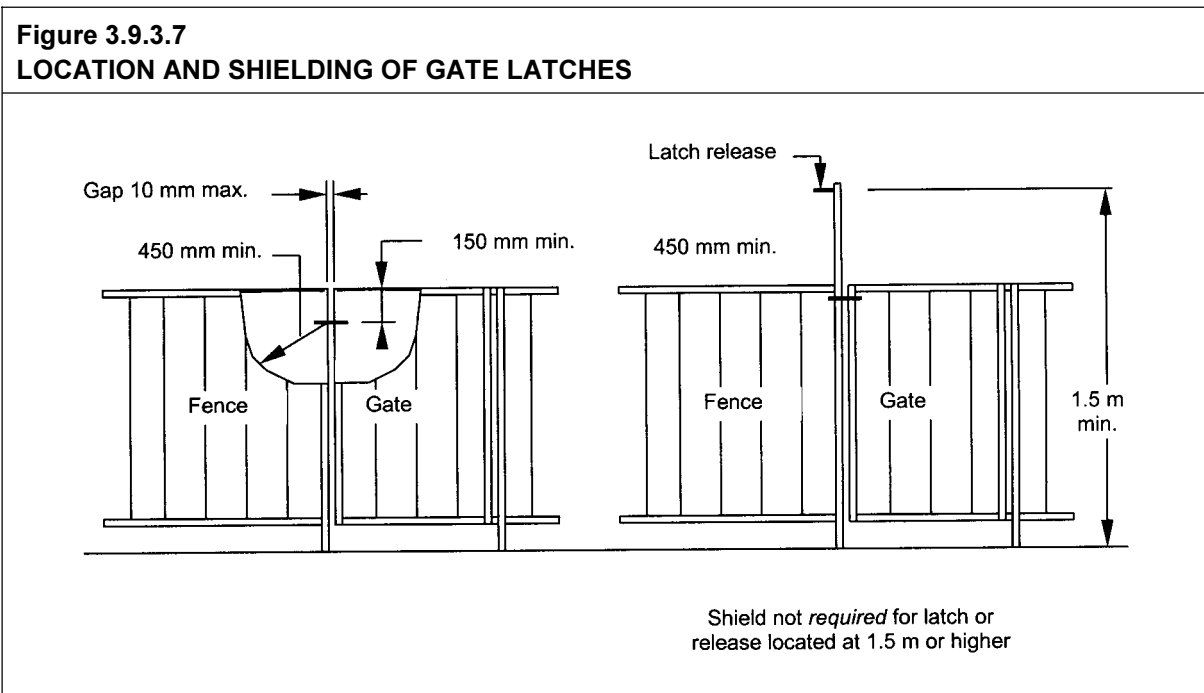

Expl. Info.
Amdt No. 5

Explanatory information:

Safety fencing should consist of barriers or walls of sufficient height and designed and constructed without openings and footholds that would enable a young child to climb through or over the fence and provided with child-resistant self-closing and latching devices on gates and doors and if incorporating an external wall of a building, any doors and openable windows to the pool area should be fitted with self-closing and latching devices that are child-resistant.

It should be noted that in NSW, Qld, WA and NT restriction of access to *swimming pools* is regulated under other legislation. ACT, Qld, SA and Tas impose additional requirements for *swimming pools* which may include provisions affecting the design of pools and pool surrounds, drainage of *swimming pools*, water recirculation and inlet and outlet openings and skimmer boxes and electrical installations.

The provisions of AS 1926.2 provide a number of options for the location of pool safety fencing. One option consists of enclosing the pool with isolation safety fencing completely separating the pool area from any other part of the allotment and any buildings. Alternatively the pool area should be separated from other parts of the allotment, any buildings and neighbouring allotments with barriers complying with the standards for safety fencing including the external wall of a building provided there is no access from the building to the pool area.

If access is provided from the building to the pool area any access door and window opening to the pool area must be protected with child-resistant doorsets and child-resistant openable portions of window.

Swimming pool safety fencing should be designed and constructed so as to be non-climbable by young children having regard to the height of the fence, any horizontal climbable members, openings and footholds in the fence and the operation of self-closing and latching gates.

Typical examples of satisfactory safety fencing are illustrated in AS 1926.1.

Amdt 11

STATE AND TERRITORY VARIATIONS

NSW var
Amdt No. 11

See ACT 6 for additional requirements for *swimming pool construction*.

See NSW 1 for additional requirements for *swimming pool construction*.

See SA 4 for additional requirements for *swimming pool construction*.

See TAS 2 for additional requirements for *swimming pool construction*.

PART **3.10**

Amdt 11

ADDITIONAL CONSTRUCTION REQUIREMENTS

- 3.10.1 High Wind Areas**
- 3.10.2 Earthquake Areas**

PART 3.10 ADDITIONAL CONSTRUCTION REQUIREMENTS

	Page
3.10.1 High wind areas	23,021
3.10.1.0 Acceptable construction manual Explanatory information	
3.10.2 Earthquake areas	23,201
3.10.2 Definitions	
3.10.2.0 Acceptable construction manuals	
3.10.2.1 Application	
3.10.2.2 Construction requirements	
3.10.2.3 Construction for areas with an acceleration coefficient of 0.12 or more but less than 0.15	
3.10.2.4 Construction for areas with an acceleration coefficient of 0.15 or more	

Amdt 11

Explanatory information:

These provisions have been introduced to address design requirements for increased structural loading conditions that may occur due to geographical, topographical or climatic conditions that are beyond the scope of the preceding Parts of the *Housing Provisions*.

These provisions are to be read in conjunction with the other relevant requirements of this code.

eg For masonry construction in Part 3.10.1, the walls will be required to be designed in accordance with AS 3700. However, the lintels, *flashings* and *damp proof courses* can be installed in accordance with Part 3.3.

PART 3.10.1 HIGH WIND AREAS

Appropriate Performance Requirements:

Where an alternative method of constructing in *high wind areas* is proposed to that described in 3.10.1.0, that method must comply with *Performance Requirement P2.1* in Section 2.

Acceptable construction manual

3.10.1.0 *Performance Requirement P2.1* is satisfied for a building constructed in a high wind area if it complies with one or more of the following manuals:

- (a) Masonry - AS 3700 Masonry structures.
- (b) The Northern Territory Deemed-to-Comply Standards Manual.
- (c) Timber-
 - (i) * * * * *
 - (ii) * * * * *
 - (iii) AS 1684.2 - Residential timber-framed construction - Non-cyclonic areas.
 - (iv) AS 1684.3 - Residential timber-framed construction - Cyclonic areas.
- (d) Steel-
 - (i) AS 3623 - Domestic metal framing; or
 - (ii) AS 4100 - Steel framing; or
 - (iii) AS 4600 - Cold-formed steel structures.
- (e) Glazed assemblies:
 - (i) AS 2047 for the following glazed assemblies in an external wall:
 - (A) Windows excluding those listed in (ii).
 - (B) Sliding doors with a frame.
 - (C) Adjustable louvres.
 - (D) Window walls with one piece framing.
 - (ii) AS 1288 for all glazed assemblies not covered by (i) and the following glazed assemblies:
 - (A) All glazed assemblies not in an external wall.
 - (B) Hinged doors, including French doors and bi-fold doors.
 - (C) Revolving doors.
 - (D) Fixed louvres.
 - (E) Skylights, roof lights and windows in other than the vertical plane.
 - (F) Sliding doors without a frame.
 - (G) Windows constructed on site and architectural one-off windows, which are not design tested in accordance with AS 2047.

Amdt No. 9

Amdt No. 9

Amdt No. 9

Amdt 11

- (H) Second-hand windows, re-used windows, recycled windows and replacement windows.
- (I) Heritage windows.
- (J) Timber windows in wind classification N3 or C1.

Expl. Info
Amdt No. 9

Explanatory information:

The reference to heritage windows in 3.10.1.0(e)(ii)(I) is intended to apply to windows in heritage buildings. The method of determining a heritage building is normally covered by the relevant State or Territory authority.

The reference to timber windows in wind classification N3 or C1 in 3.10.1.0(e)(ii)(J) is limited to a six month period to allow industry time to expand the generic design provisions in AS 2047 to include designs suitable for these wind classifications. After this period, timber windows in wind classification N3 or C1 will need to fully comply with AS 2047.

Amdt 11

STATE AND TERRITORY VARIATIONS

Add 3.10.1.0(f) and (g) in the Northern Territory.

- (f) Metal clad roofing
Test for strength - Metal roofing and its fitments should be capable of withstanding without failure, the test application of 10,000 cycles of working load from zero to that maximum at a rate of 3 Hz, followed by a static load test of 1.8 times the working load.
- (g) Masonry veneer - Masonry veneer construction must be designed so that the structural framing to which the masonry veneer is tied will ensure the stability of the masonry veneer.

3.10.1.0(g)
Amdt No. 2

Qld var.
Amdt No. 9

STATE AND TERRITORY VARIATIONS

3.10.1.0(e)(i) is replaced by the following clause in Queensland:

- (i) AS 2047 for the following glazed assemblies in an external wall, with the exception that Tables 2.1 and 2.5 of AS 2047 are omitted and the following Tables are inserted:
 - (A) Windows excluding those listed in (ii).
 - (B) Sliding doors with a frame.
 - (C) Adjustable louvres.
 - (D) Window walls with one piece framing.

TABLE 2.1	
WINDOW RATINGS FOR HOUSING	
Window rating	Serviceability design wind pressure, Pa
N1	500
N2	700
N3, C1	1000
N4, C2	1500
N5, C3	2200
N6, C4	3000

TABLE 2.5	
ULTIMATE STRENGTH TEST PRESSURES	
Window rating	Ultimate strength test pressure, Pa
N1	700
N2	1000
N3, C1	1500
N4, C2	2300
N5, C3	3300
N6, C4	4500

Amdt 11

Figure 3.10.1.4
CYCLONIC AREAS

Note: High wind areas exist outside the cyclonic regions indicated on this map.

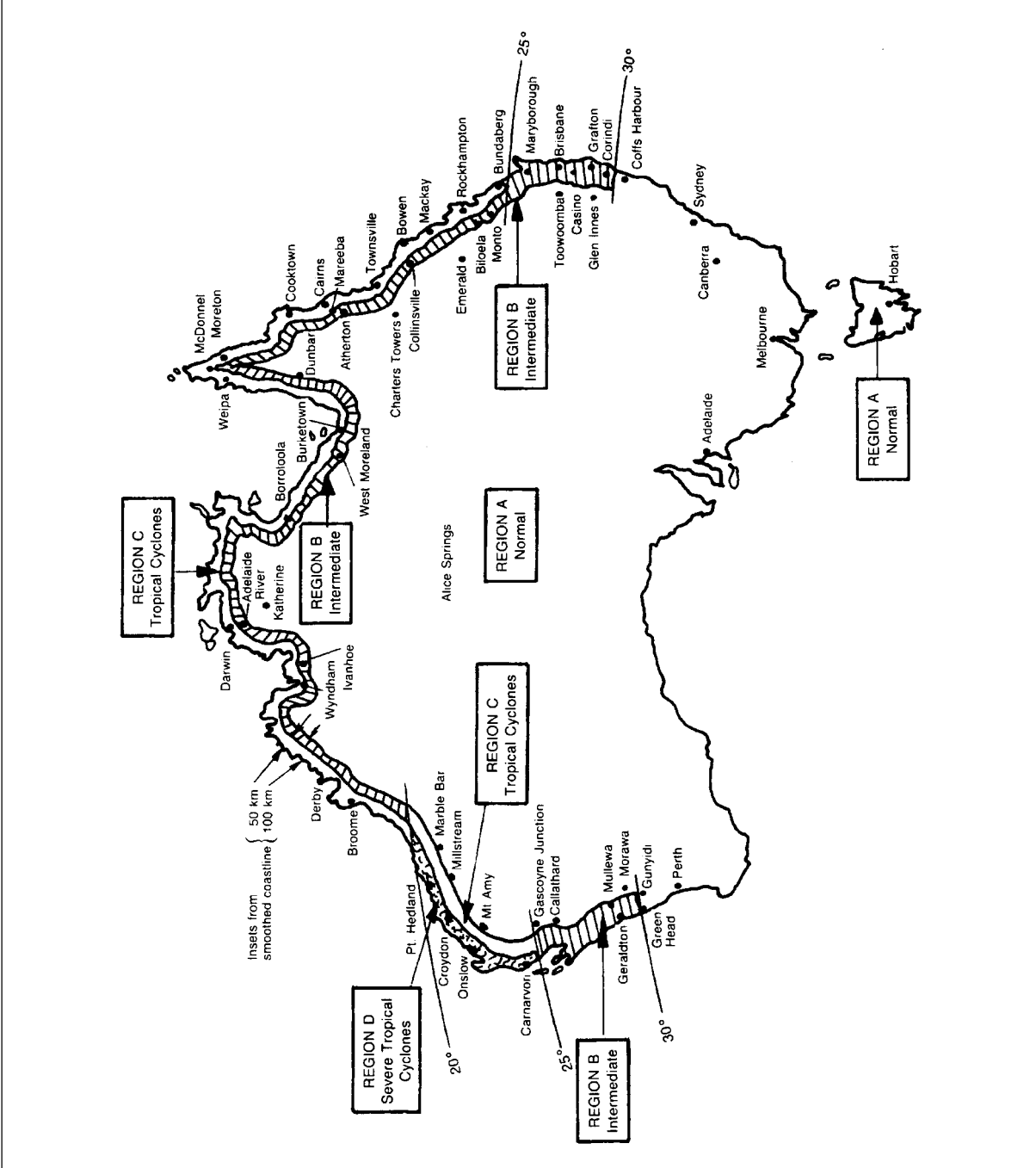

Amdt 11

Explanatory information: Construction in *high wind areas*

The intent of building construction in *high wind areas* is to ensure the structure has sufficient strength to transfer wind forces to the ground with an adequate safety margin to prevent the collapse of the building and the building being lifted, or slid off its foundations.

To resist these forces it is necessary to have-

- (a) an anchorage system, where the roof is connected by the walls to the footings by a chain of connections; and
- (b) a bracing system to prevent horizontal collapse due to wind forces; and
- (c) continuity of the system where each structural element is interlocked to its adjoining structural element throughout the building.

Anchorage

Anchorage of the system is achieved by using a variety of proprietary connectors. Each connector must be capable of carrying the uplift force, because the ability of the building to resist the wind forces is directly related to its weakest link.

Acceptable construction manuals to achieve these requirements are described in this Part.

PART 3.10.2 EARTHQUAKE AREAS

Appropriate Performance Requirements:

Where an alternative design is proposed to that described in Part 3.10.2, that proposal must comply with *Performance Requirement P2.1* in Section 2.

Definitions

3.10.2 The following definitions are used in this Part:

Acceleration coefficient means an index related to the expected severity of earthquake ground motion, as determined under AS 1170.4 and described in Figure 3.10.2.1.

Design category: means the *design category* given in Table 2.6 of AS 1170.4. Domestic structures are separated into three earthquake design categories H1, H2 and H3 in order of increasing potential to be damaged by earthquake loads.

Framing connector means a manufactured connector system for timber joints formed from 1.2 mm minimum thickness galvanised steel and punched to take nails.

A. Acceptable construction manuals

3.10.2.0 *Performance Requirement P2.1* for Class 1 and 10 buildings constructed in areas subject to seismic activity is satisfied if the building is constructed in accordance with the applicable construction manuals listed in Part 3.11.

Explanatory information:

Most domestic structures are not required to be specifically designed for earthquakes, because the construction system already in place for wind resistance is usually adequate for earthquake resistance.

Accordingly, compliance with other acceptable construction details in the *Housing Provisions* are suitable for areas with an acceleration co-efficient below 0.12 provided the building is built in an area that is not considered to be complying with a structural *design category* of H3 as defined in AS 1170.4.

Class H3 are typically *sites* identified as having soft soil (having a soil profile with more than 5 m of soft clay, loose sand, silt or uncontrolled fill) which need to be designed in accordance with Part 3.11.

B. Acceptable construction practice**3.10.2.1 Application****3.10.2.1
Amdt No. 2**

Compliance with this Part for Class 1 and 10 buildings constructed in areas with a seismic activity *acceleration coefficient* of 0.12 or more satisfies *performance requirement* P2.1, provided –

- (a) the soil profile of the *site* does not have more than 5 m of soft clay, loose sand, silt or uncontrolled fill; and
- (b) the buildings-
 - (i) have a rise in storeys not more than 1; and
 - (ii) do not have-
 - (A) a roof clad with concrete or terracotta tiles; or
 - (B) masonry projections or overhangs, masonry parapets or unbraced masonry chimneys.

Amdt 11**3.10.2.2 Construction requirements**

Construction in earthquake areas must comply with the following:

- (a) In locations with an *acceleration coefficient* of 0.12 or more but less than 0.15, a Class 1 and 10 building must comply with 3.10.2.3.
- (b) In locations with an *acceleration coefficient* of 0.15 or more, a Class 1 and 10 building must comply with 3.10.2.4.
- (c) See Figure 3.10.2.1 for *acceleration coefficient* design values.

Explanatory information:

The principal requirement for structural detailing in domestic structures is that each of the system components are sufficiently connected together such that the forces generated by an earthquake are carried to the foundation.

Trusses, beams and the like should be restrained horizontally at their support, and for this purpose, framing connectors are sufficient.

Bracing requirements, in horizontal and vertical directions, are the same as for wind loads.

Figure 3.10.2.1
ACCELERATION CO-EFFICIENT MAP OF AUSTRALIA

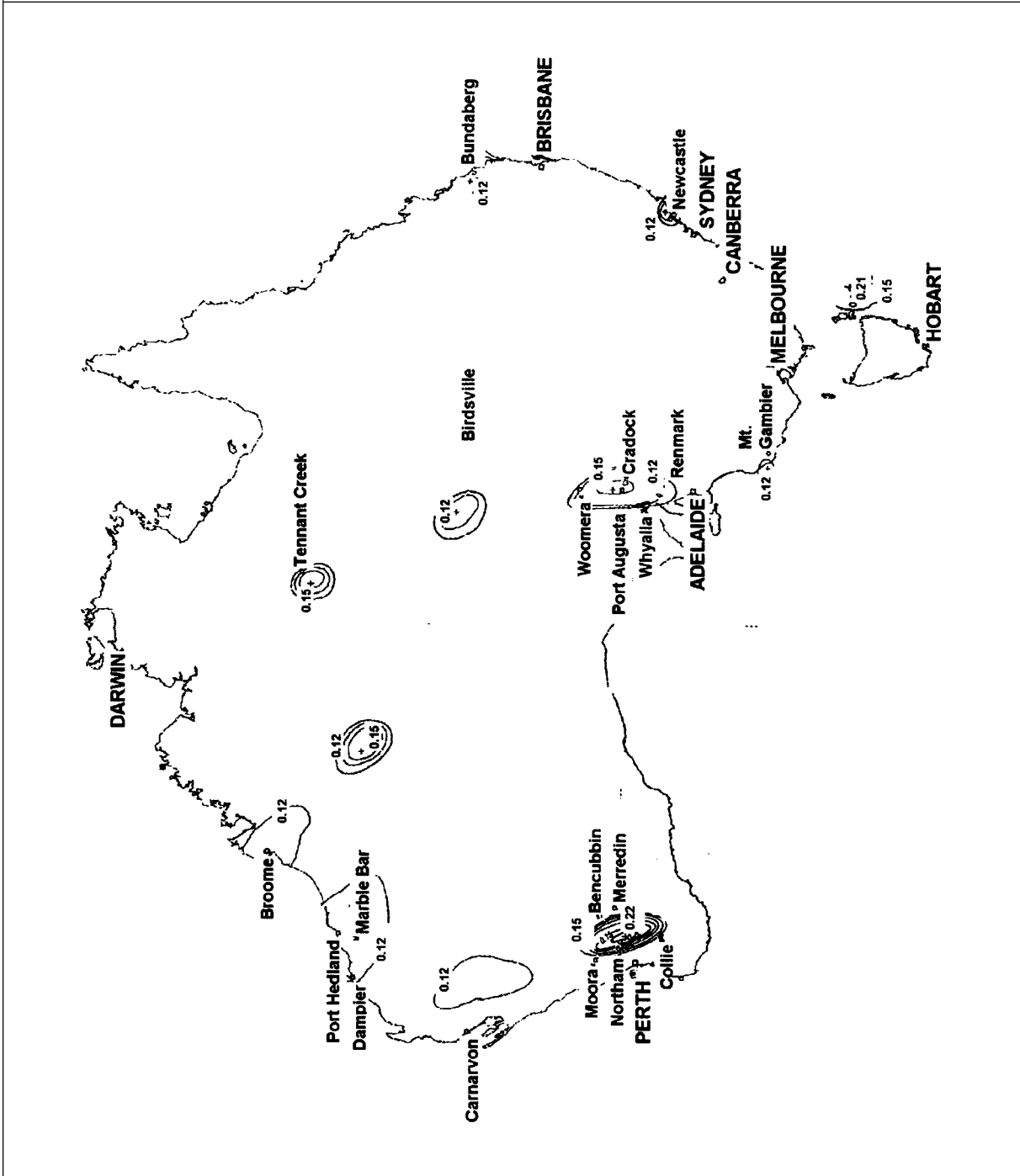

Amdt 11

3.10.2.3 Construction for areas with an acceleration coefficient of 0.12 or more but less than 0.15

Buildings in areas with an *acceleration coefficient* of 0.12 or more but less than 0.15 must be constructed as follows:

- (a) Footings must comply with the appropriate provisions of Part 3.2 and the additional requirements of this clause:
- (i) Stumps must be steel, timber or reinforced concrete.
 - (ii) Bracing to stumps must be connected with galvanised M12 bolts or equivalent to comply with AS 1684 Part 2, 3 or 4-
 - (A) at not more than 10 m intervals; and
 - (B) at corner stumps - in two directions; and
 - (C) to every stump projecting more than 650 mm out of the ground.
 - (iii) Floor beams must be fixed to the top of stumps with two M10 diameter bolts or equivalent fixing.
 - (iv) Bottom plates of framed structures, where fixed to a concrete slab or strip footing, must be fixed with M10 bolts or masonry anchors at not more than 1.2 m centres.
 - (v) Concrete strip footings must be continuously reinforced with two layers of reinforcement comprising two 12 mm diameter bars (Grade 400Y) per layer and tied with R6 ligatures at centres not more than 2.5 times the depth of the footing.
 - (vi) Raft slabs must incorporate monolithic edge beams.
- (b) Framed wall construction must comply with the appropriate provisions of Part 3.4 and the additional requirements of this clause:
- (i) Metal framing must-
 - (A) comply with Part 3.4, AS 1538, AS/NZS 1664.1 or AS/NZS 1664.2; and
 - (B) be not less than 1.2 mm thick (other than bracing); and
 - (C) have wall plates that are continuous between cross walls or spliced to maintain strength.
 - (ii) Timber framing-
 - (A) must be fixed with timber *framing connectors* nailed with not less than three 2.8 mm diameter x 30 mm long nails to each fixing plate or the connector; and
 - (B) must be constructed of seasoned timber, fixed with at least two 2.8 mm diameter nails, machine nailed through the top or bottom wall plate into the stud; and

Amdt No. 8

3.10.2.3
(b)(i)(A)
Amdt No. 33.10.2.3
(b)(ii)(B)
Amdt No. 3

Amdt 11

- (C) wall plates must be continuous between cross walls or spliced to maintain strength.
- (c) *Unreinforced masonry* must comply with the appropriate provisions of Part 3.3 and the additional requirements of this clause:
- (i) Internal or *external walls* 4 m or more in length must be stiffened by cross walls, columns or bracing complying with AS 1170.4 and AS 3700; and-
- (A) cross walls must be tied to the internal leaf of *cavity walls* by fully bonding or by metal ties at every second course; and
- (B) the mortar mix must be at least as strong as a 1:1:6; and
- (C) masonry units must have good mortar adherence properties.
- (ii) Bricks must-
- (A) be laid on a full bed joint with full perpend; and
- (B) when laid in the top two courses of internal walls and the internal leaf of *external walls*, contain no perforations.
- (iii) Reinforcement consisting of two R6 bars (Grade 250R), or two 3.15 mm diameter bars (Grade 450W), must-
- (A) be placed in both leaves of *external walls* in the course immediately under *window sills* and over door and *window heads*; and
- (B) be galvanised when placed in the external leaf of an *external wall*; and
- (C) extend not less than 300 mm beyond any supporting cross walls or columns; and
- (D) be spliced not less than 300 mm.
- (iv) Continuous reinforced brick bond beams must be installed, comprising two R6 bars (Grade 250R), or two 3.15 mm diameter bars (Grade 450W), in each of the top three bed joints, constructed-
- (A) on the internal leaf of all *external walls* and on all cross walls; and
- (B) where the roof is pitched on the external leaf of an *external wall*, in that external leaf; and
- (C) in cross walls, turned and lapped 300 mm into the *external walls*.
- (v) Top wall plates must be fixed by masonry anchors or equivalent fixing connected to the second top course of walls, at not more than 1.8 m centres.

- (d) Veneers that comprise an external leaf of masonry connected to internal walls of timber or metal framing must be fixed in accordance with AS 3700.
- (e) Roof framing must comply with the appropriate provisions of Part 3.4: and
 - (i) be fixed to the top wall plate using timber *framing connectors* nailed with not less than three 2.8 mm diameter x 30 mm long nails to each fixing plate of the connector; and
 - (ii) incorporate roof bracing to transfer all horizontal loads directly to cross walls.

3.10.2.4 Construction for areas with an acceleration coefficient of 0.15 or greater

Buildings in areas with an *acceleration coefficient* of 0.15 or greater must be constructed as follows:

- (a) Footings must comply with the appropriate provisions of Part 3.2 and the additional requirements of this clause:
 - (i) Stumps must be steel, timber or reinforced concrete.
 - (ii) Bracing to stumps must be connected with galvanised M12 bolts or equivalent to comply with AS 1684 Part 2, 3 or 4-
 - (A) at not more than 8 m intervals; and
 - (B) at corner stumps - in two directions; and
 - (C) to every stump projecting more than 500 mm out of the ground.
 - (iii) Floor beams must be fixed to the top of stumps with two M10 diameter bolts or equivalent fixing.
 - (iv) Bottom plates of framed structures, where fixed to a concrete raft or strip footing, must be fixed with M10 bolts or masonry anchors at not more than 1.2 m centres.
 - (v) Concrete strip footings must be continuously reinforced with two layers of reinforcement comprising two 12 mm diameter bars (Grade 400Y) per layer and tied with R6 ligatures at centres not more than 2.5 times the depth of the footing.
 - (vi) Raft slabs must incorporate monolithic edge beams.
- (b) Framed wall construction must comply with the appropriate provisions of Part 3.4 and the additional requirements of this clause:
 - (i) Metal framing-
 - (A) must comply with Part 3.4, AS 1538 or AS/NZS 1664.1 or AS/NZS 1664.2; and
 - (B) must be not less than 1.2 m thick (other than bracing); and

3.10.2.4
(a)(ii)
Amdt No. 8

3.10.2.4
(b)(i)(A)
Amdt No. 4

Amdt 11

- (C) wall plates must be continuous between cross walls or spliced to maintain strength.
- (ii) Timber framing must comply with the following-
 - (A) *Timber framing connectors* must be nailed with not less than three 2.8 mm diameter x 30 mm long nails to each fixing plate or the connector.
 - (B) Seasoned timber, must be fixed with not less than two 2.8 mm diameter nails, machine nailed through the top or bottom wall plate into the stud.
 - (C) Wall plates must be continuous between cross walls or spliced to maintain strength.
- (c) Veneer on frame construction must comply with the following:
 - (i) Veneers that comprise an external leaf of masonry connected to internal walls of timber or metal framing must be fixed in accordance with AS 3700.
 - (ii) Timber framing:
 - (A) Wall plates must be-
 - (aa) fixed to transfer lateral loads between frames of *external walls* and frames of internal walls; and
 - (bb) at least F8 grade timber minimum dimensions not less than 100 x 50 mm where cross walls are spaced at not more than 4.8 m centres.
 - (B) *External walls* must be fixed to supporting cross walls at or near top wall plate level by not less than two *framing connectors* with not less than three 2.8 mm diameter nails to each plate of the connector or by bolting the frames together with M10 minimum diameter bolts.
 - (iii) Metal framing:
 - (A) Wall plates must-
 - (aa) be fixed to transfer lateral loads between frames of *external walls* and frames of internal walls; and
 - (bb) have minimum dimensions of 78x31x1.2 mm where cross walls are spaced at not more than 5.5 m centres, and stiffened by an additional 75x78x1.6 mm plate where the span is more than 3.5 m.
 - (B) *External walls* must be fixed to supporting cross walls at or near top wall plate level by at least two *timber framing connectors* or by bolting the frames together with M10 minimum diameter bolts.

- (iv) The veneer of *external walls* must be fixed to the frame with 100 x 100 mm galvanised steel mesh.
- (v) Masonry veneer must not be placed over openings or in gables.
- (d) Roof framing must comply with the appropriate provisions of Part 3.4; and
 - (i) incorporate roof bracing to transfer all horizontal loads directly to cross walls; and
 - (ii) be fixed to the top wall plate using timber *framing connectors* nailed with at least three 2.8 mm diameter x 30 mm long nails to each fixing plate of the connector.

PART **3.11**

Amdt 11

STRUCTURAL DESIGN MANUALS

- 3.11.1 Application**
- 3.11.2 Acceptable Structural Design Manuals**
- 3.11.3 Loading Requirements**
- 3.11.4 Structural Design Manuals**

PART 3.11 STRUCTURAL DESIGN MANUALS

		Page
3.11	Structural design manuals	25,021
3.11.1	Application	
3.11.2	Acceptable structural design manuals	
3.11.3	Loading requirements	
3.11.4	Structural design manuals	

Explanatory information:

This Part of the *Housing Provisions* contains a list of deemed-to-satisfy codes (structural design manuals) that can be used to design building elements using engineering principles.

These provisions can be used in conjunction with both the *Performance Requirements* (listed in Section 2) and the *Deemed-to-Satisfy Provisions* (listed in Section 3 - Parts 1 to 11). This combined approach is acceptable and meets the requirements of the *Housing Provisions*.

PART 3.11 STRUCTURAL DESIGN MANUALS

Appropriate *Performance Requirements*:

Where it is proposed to use an alternative structural design manual to that described in Part 3.11, that proposal must comply with *Performance Requirement P2.1* in Section 2.

Acceptable construction manuals

3.11.1 Application

Amdt No. 11 *Performance Requirement P2.1* is satisfied by complying with-

- (a) 3.11.2 to 3.11.4; or
- (b) the relevant provisions of other Parts of Section 3 of the *Housing Provisions* relating to structural elements; or
- (c) a combination of (a) and (b).

3.11.2 Resistance to actions

3.11.2
Amdt No. 11 The resistance of a building or structure must be greater than the most critical action effect resulting from different combinations of actions, where-

- (a) the most critical action effect on a building or structure must be determined in accordance with 3.11.3 and the general design procedures contained in AS/NZS 1170.0; and
- (b) the resistance of a building or structure must be determined in accordance with 3.11.4.

3.11.3 Determination of individual actions

3.11.3
Amdt No. 11 The magnitude of individual actions must be determined in accordance with the following:

- (a) Permanent actions:
 - (i) the design or known dimensions of the building or structure; and
 - (ii) the unit weight of the construction; and
 - (iii) AS/NZS 1170.1.
- (b) Imposed actions:
 - (i) the known loads that will be imposed during the occupation or use of the building or structure; and
 - (ii) *construction activity actions*; and
 - (iii) AS/NZS 1170.1.

- (c) Wind, snow and earthquake actions:
 - (i) the applicable annual probability of design event for safety, determined by-
 - (A) assigning the building or structure an Importance Level in accordance with Table 3.11.3a; and
 - (B) determining the corresponding annual probability of exceedance for safety in accordance with Table 3.11.3b; and
 - (ii) AS/NZS 1170.2, AS 1170.3 and AS 1170.4 as appropriate.
- (d) Action not covered in (a), (b) and (c) above:
 - (i) the nature of the action; and
 - (ii) the nature of the building or structure; and
 - (iii) the Importance Level of the building or structure determined in accordance with Table 3.11.3a; and
 - (iv) AS/NZS 1170.1.
- (e) For the purposes of (d) the actions include but are not limited to-
 - (i) liquid pressure action; and
 - (ii) ground water action; and
 - (iii) rainwater action (including ponding action); and
 - (iv) earth pressure action; and
 - (v) differential movement; and
 - (vi) time dependent effects (including creep and shrinkage); and
 - (vii) thermal effects; and
 - (viii) ground movement caused by-
 - (A) swelling, shrinkage or freezing of the subsoil; and
 - (B) landslip or subsidence; and
 - (C) siteworks associated with the building or structure; and
 - (ix) *construction activity actions*.

Amdt 11

Table 3.11.3a	
IMPORTANCE LEVELS OF BUILDINGS AND STRUCTURES	
Importance Level	Building types
1	Buildings or structures presenting a low degree of hazard to life and <i>other property</i> in the case of failure.
2	Buildings or structures not included in Importance Level 1.

Table 3.11.3b DESIGN EVENTS FOR SAFETY				
Importance Level	Annual probability of exceedance			
	Wind		Snow	Earthquake
	Non-cyclonic	Cyclonic		
1	1:100	1:200	1:100	1:500
2	1:500	1:500	1:150	1:500

3.11.4 Determination of structural resistance of materials and forms of construction

3.11.4
Amdt No. 11

The structural resistance of materials and forms of construction must be determined in accordance with the following:

- (a) Steel construction:
 - (i) AS/NZS 4600 - Cold formed steel structures.
 - (ii) AS 3623 - Domestic metal framing.
 - (iii) AS 4100 - Steel structures.
- (b) Aluminium construction:
 - (i) AS/NZS 1664 – Aluminium structures, Part 1 – Limit state design.
 - (ii) AS/NZS 1664 – Aluminium structures, Part 2 – Allowable stress design.
- (c) Timber construction:

AS 1720.1 - Timber structures code.
- (d) Footings:
 - (i) AS 2870 - Residential slabs and footings.
 - (ii) AS 3600 - Concrete structures.
- (e) Piling:

AS 2159 - Piling - Design and information.
- (f) Concrete construction (including reinforced and prestressed concrete):

AS 3600 - Concrete structures.
- (g) Masonry (including masonry-veneer, *unreinforced masonry* and *reinforced masonry*):

AS 3700 - SAA Masonry structures.
- (h) Composite steel and concrete:

AS 2327.1 - Composite construction in steel and concrete.

Amdt 11

- (i) Glazed assemblies:
 - (i) AS 2047 for the following glazed assemblies in an external wall:
 - (A) Windows excluding those listed in (ii).
 - (B) Sliding doors with a frame.
 - (C) Adjustable louvres.
 - (D) Window walls with one piece framing.
 - (ii) AS 1288 for all glazed assemblies not covered by (i) and the following glazed assemblies:
 - (A) All glazed assemblies not in an external wall.
 - (B) Hinged doors, including French doors and bi-fold doors.
 - (C) Revolving doors.
 - (D) Fixed louvres.
 - (E) Skylights, roof lights and windows in other than the vertical plane.
 - (F) Sliding doors without a frame.
 - (G) Windows constructed on site and architectural one-off windows, which are not design tested in accordance with AS 2047.
 - (H) Second-hand windows, re-used windows, recycled windows and replacement windows.
 - (I) Heritage windows.

Expl. Info
Amdt No. 11**Explanatory information:**

The reference to heritage windows in 3.11.4(i)(ii)(I) is intended to apply to windows in heritage buildings. The method of determining a heritage building is normally covered by the relevant State or Territory authority.

Qld var.
Amdt No. 9

STATE AND TERRITORY VARIATIONS

3.11.4(i)(i) is replaced by the following clause in Queensland:

- (i) AS 2047 for the following glazed assemblies in an external wall, with the exception that Tables 2.1 and 2.5 of AS 2047 are omitted and the following Tables are inserted:
 - (A) Windows excluding those listed in (ii).
 - (B) Sliding doors with a frame.
 - (C) Adjustable louvres.
 - (D) Window walls with one piece framing.

TABLE 2.1	
WINDOW RATINGS FOR HOUSING	
Window rating	Serviceability design wind pressure, Pa
N1	500
N2	700
N3, C1	1000
N4, C2	1500
N5, C3	2200
N6, C4	3000

TABLE 2.5	
ULTIMATE STRENGTH TEST PRESSURES	
Window rating	Ultimate strength test pressure, Pa
N1	700
N2	1000
N3, C1	1500
N4, C2	2300
N5, C3	3300
N6, C4	4500

- (j) Earthwall construction.
NBTC Bulletin 5, Edition 4.
- (k) Structures for primary production purposes in rural areas:
AS 2867 – Farm structures – General requirements for structural design.

Amdt 11

APPENDIX **A**

Amdt 11

STATE AND TERRITORY ADDITIONS

Australian Capital Territory

New South Wales

Northern Territory

Queensland

South Australia

Tasmania

Victoria

Western Australia

APPENDIX A - STATE AND TERRITORY ADDITIONS

	Page
CONTENTS	
AUSTRALIAN CAPITAL TERRITORY	50,021
Structure	
ACT 1 - * * * * *	
Health and amenity	
ACT 2 - Hazardous materials	
ACT 3 - Control of Litter on Building Sites	
ACT 4 - Waste Management	
ACT 5 - Energy Efficiency	
Safe movement and access	
ACT 6 - Swimming pools	
NEW SOUTH WALES - No additional provisions	50,201
NORTHERN TERRITORY - No additional provisions	50,401
QUEENSLAND	50,601
Health and amenity	
QLD 1 - * * * * *	
QLD 2 - Flashing of narrow spaces and vermin control	
SOUTH AUSTRALIA	50,801
Acceptable construction manual	
SA 1 - Application	
Health and amenity	
SA 2 - Energy efficiency	
SA 3 - Wet areas	
Safe movement and access	
SA 4 - Swimming pool safety	
SA 5 - Access for people with disabilities	
SA 6 - Access for inspection and maintenance	
Continued next page	

Amdt 11

	Page
TASMANIA	51,001
Fire safety	
TAS 1 - Non-combustible roofing	
Safe movement and access	
TAS 2 - Swimming pool water reticulation and filtration	
VICTORIA	51,201
Health and amenity	
VIC 1 - Energy efficiency	
Special requirements for certain buildings and components	
WESTERN AUSTRALIA - No additional provisions	51,401

Amdt 11

AUSTRALIAN CAPITAL TERRITORY ADDITIONS

Application of Australian Capital Territory additions

This Appendix contains additional provisions for application in the Australian Capital Territory as follows:

ACT 1 - * * * * *

ACT 1
Amdt No. 3

This clause has been deliberately left blank.

Amdt 11

HEALTH AND AMENITY

ACT 2 - HAZARDOUS MATERIALS

ACT 2.1 PERFORMANCE PROVISIONS

Objective

The *Objective* is to safeguard people from illness resulting from exposure to asbestos building materials during removal and disposal.

Functional Statement

Asbestos building material shall be removed and disposed of in a safe manner.

Performance Requirement

When asbestos-based material in any form or in any mixture thereof, or any material containing loose asbestos including asbestos fluff insulation, asbestos sheeting, lagging, fire protection and the like is removed, it must be handled and disposed of safely.

ACT 2.2 ACCEPTABLE CONSTRUCTION PRACTICE

The requirements of ACT P2 are satisfied when asbestos-based materials are handled and disposed of in accordance with the Worksafe Australia Code of Practice and Guidance Notes.

ACT 3 - CONTROL OF LITTER ON BUILDING SITES**ACT 3.1 PERFORMANCE PROVISIONS****Objective**

The *Objective* of this provision is to prevent wind blown litter from building sites fouling roads and public land.

Functional Statement

Building litter must be prevented from spreading around the site and beyond the site boundary.

Performance Requirement

Sufficient containers must be provided on building sites to store building waste that is likely to become windblown.

ACT 3.2 ACCEPTABLE CONSTRUCTION PRACTICE

The requirements of ACT P3 are satisfied by:

On site building waste that is stored in suitable size plastic or metal bins and removed from the site at regular intervals.

Note: Building Waste includes: plastic containers and plastic and paper wrappings or any waste that can be carried by wind.

ACT 4 - WASTE MANAGEMENT**ACT 4.1 PERFORMANCE PROVISIONS****Objective**

The *Objective* of this provision is to safeguard people from injury caused by infection or contamination from solid waste.

Functional Statement

Buildings must be provided with space and facilities for the collection, and safe hygienic holding prior to disposal of solid waste arising from the intended use of the building.

Performance Requirement

Where provision is made within buildings for the collection and temporary holding of solid waste, the design shall accommodate screening, volume of waste, disposal, logistics and access.

ACT 4.2 ACCEPTABLE CONSTRUCTION PRACTICEACT 4.2
Amdt No. 6

The requirements of ACT P4 are satisfied by garbage facilities that are designed and constructed in accordance with the Development Control Code for Best Practice Waste Management in the ACT.

ACT 5 – ENERGY EFFICIENCY**Limitation:**

ACT 5 applies to Class 1 buildings only.

ACT 5.1 PERFORMANCE PROVISIONSACT 5.1
Amdt No. 4**Objective**

The *Objective* of this Part is to facilitate efficient use of energy in a building.

Functional Statement

A building is to be designed to achieve efficient use of energy for internal heating and cooling.

Performance Requirement

A building must have an adequate level of thermal performance to ensure efficient use of energy for internal heating and cooling.

ACT 5.2 ACCEPTABLE CONSTRUCTION PRACTICE**ACT 5.2.1 Energy efficiency**ACT 5.2.1
Amdt No. 11

The requirements of ACT P5 are satisfied by-

- (a) A building that achieves an ACT House Energy Rating of 4 Stars as assessed by an accredited ACT House Energy Assessor; or
- (b) by any other assessment method, satisfying P5; and
- (c) in the case of an addition to an existing building, by-
 - (i) complying with P5 or (a); or
 - (ii) complying with ACT Table 1 and having-
 - (A) a concrete floor; or
 - (B) a timber floor with an R rating of 1 including carpets.

<p>ACT Table 1 MINIMUM INSULATION MATERIAL</p>
<p>Roofs</p> <p>(a) R3 insulation material in the ceiling space; or</p> <p>(b) R2 insulation material in exposed raked ceiling (concession).</p> <p>Walls</p> <p>R1.5 insulation material in the external wall space.</p>

Amdt 11

ACT 5.2.2 Exemptions

- ACT 5.2.2**
Amdt No. 3 The requirements of this Part do not apply to the following types of construction:
- (a) Cavity brick, earthwall construction, ashlar stone or other masonry walls which have a thickness (excluding any cavity) of not less than 180 mm do not require wall insulation.
 - (b) Class 10 structures forming part of a Class 1 building.
 - (c) Moveable dwellings and mobile homes where their form of prefabricated construction does not readily permit achievement of optimal insulation requirements.

ACT 5.2.3 Fire resistance of insulation materials

ACT 5.2.3
Amdt No. 6 When tested in accordance with AS/NZS 1530.3 a thermal insulation material must have a *Spread-of-Flame Index* of 0 and a *Smoke-Developed Index* not greater than 4.

ACT 6 - SWIMMING POOL CONSTRUCTION

Application:
This requirement is to be applied in conjunction with Part 3.9.3.

ACT 6.1 Swimming pool construction

- Indoor or outdoor permanent bathing, wading and *swimming pools* must-
- (a) where the capacity of the pool exceeds 10 m³-
 - (i) be of the recirculation type in which the water circulation is maintained through the pool by pumps, the water drawn from the pool being clarified and disinfected before being returned to the pool; and

- (ii) have an outlet sump with antivortex cover or grating and have a skimming weir or overflow gutter or channel at high water level; and;
- (iii) have means of egress provided in the form of ladders, steps in the floor of the pool or a ramp; and
- (b) be capable of being completely emptied and any discharge or overflow and pool backwash filter must be connected to the sewer drainage system; and
- (c) be watertight with smooth surfaces of non-absorbent, non-slip material, light in colour and with rounded corners to facilitate cleaning; and
- (d) have surrounding concourses graded away from the pool.

Amdt 11

OTHER LEGISLATION AFFECTING BUILDINGS

In addition to the requirements of the ACT Building Act 1972 and the ACT Building Code, administered by ACT Building Electrical and Plumbing Control, (BEPCON) builders and designers should be aware of other legislation which contains building requirements.

The following is a list of some of the other relevant legislation:

ACT
Amdt No. 9

- 1. Health Legislation**
Public Health Regulations 2000 (Dept of Health, Housing and Community Care)
- 2. Environmental Control and Emission Standards**
Environment Protection Act 1997 (Department of Urban Services (DUS))
- 3. Occupational Health and Safety**
ACT Demolition Code of Practice (ACT WorkCover)
Occupational Health and Safety Act 1989 (ACT WorkCover)
- 4. Public Housing**
Housing Assistance Act 1987 (ACT Housing, ACT Health Trust)
- 5. Scaffolding and Temporary Works**
Scaffolding and Lifts Regulations 1950 (ACT WorkCover)
- 6. Urban Design Standards, Land Title and Tenure**
ACT (Planning and Land Management) Act 1988 (National Capital Authority) (NCA)
City Area Leases Act 1936 (For leases before the Land Act commenced) (DUS)
Common Boundaries Act 1981 (DUS)
Land (Planning and Environment) Act 1991 (DUS)
Leases (Special Purposes) Act 1925 (For leases before the Land Act commenced) (DUS)
National Land Ordinance 1989 (NCPA)
Unit Titles Act 1970 (DUS)
- 7. Utility Services and Urban Infrastructure**
Electricity Safety Act 1971 (BEPCON, DUS)
Gas Supply Act 1998 (ActewAGL, ACT WorkCover)
Protection of Lands Act 1937 (DUS)
Roads and Public Places Act 1937 (DUS)
Utilities Act 2000 (Department of Treasury, DUS)
Water and Sewerage Act 2000 (DUS)

Amdt 11

NEW SOUTH WALES ADDITIONS

Application of New South Wales additions

This Appendix contains additional provisions for application in New South Wales as follows:

NSW 1 – WATER RECIRCULATION AND FILTRATION SYSTEMS

NSW 1
Amdt No. 11

Amdt 11

NSW 1.1 PERFORMANCE PROVISIONS

Objective

The *Objective* is to safeguard young children from drowning or injury in a *swimming pool*.

Functional Statement

A *swimming pool* must be provided with means to minimise the risk of entrapment or injury of young children using the pool.

Performance Requirement

The water recirculation and filtration system in a *swimming pool* must incorporate safety measures to avoid entrapment of or injury to a young child.

NSW 1.2 ACCEPTABLE CONSTRUCTION PRACTICE

NSW 1.2.1 Application

For a *swimming pool* with a depth of water more than 300mm, compliance with the provisions of NSW 1.2 for water recirculation and filtration systems satisfies *Performance Requirement* NSW 1.1.

NSW 1.2.2 Water recirculation and filtration system

A *swimming pool* water recirculation and filtration system must comply with AS 1926.3.

NORTHERN TERRITORY ADDITIONS

The Northern Territory has no additions to the Housing Provisions.

Amdt 11

QUEENSLAND ADDITIONS

Application of Queensland variations

This Appendix contains additional provisions for application in Queensland as follows:

HEALTH AND AMENITY

QLD 1 - * * * * *

QLD 1
Amdt No. 3

This clause has been deliberately left blank.

Amdt 11

QLD 2 - FLASHING OF NARROW SPACES AND VERMIN CONTROL

QLD 2.1 PERFORMANCE PROVISIONS

Objective

The *Objective* is to safeguard people from injury and illness resulting from the creation of hazardous spaces between buildings.

Functional Statement

The space between buildings must not allow hazardous conditions to arise due to vermin and weather.

Performance Requirement

Spaces between buildings on adjoining sites which are narrower than 600 mm must be sealed off and flashed over to prevent the entrance of weather and vermin.

QLD 2.2 ACCEPTABLE CONSTRUCTION PRACTICE

Qld 2.2.1 Control of vermin

Buildings must be constructed to prevent the entry of vermin in accordance with Part 17 (Vermin Control) of the Health Regulation 1996.

SOUTH AUSTRALIA ADDITIONS

Application of South Australian variations

This Appendix contains additional provisions for application in South Australia as follows:

SA ACCEPTABLE CONSTRUCTION MANUAL

SA 1 APPLICATION

SA 1
Amdt No. 6

Compliance with the *Deemed-to-Satisfy Provisions* of the South Australian Housing Code for Class 1a and Class 10a buildings satisfies the *Performance Requirements* in Section 2 as modified by any variations and additions for South Australia.

HEALTH AND AMENITY

SA 2 - ENERGY EFFICIENCY

SA 2
Amdt No. 11

Limitation:

SA 2 applies to new Class 1 buildings only. SA 2 does not apply to alterations or additions to existing Class 1 buildings.

SA 2.1 PERFORMANCE PROVISIONS

Objective

The *Objective* of this Part is to facilitate efficient use of energy in a building to minimise greenhouse gas emissions.

Functional Statement

A building is to be designed and constructed to achieve efficient use of energy for internal heating and cooling.

Performance Requirement

A building must have an adequate level of thermal performance to ensure efficient use of energy for internal heating and cooling.

SA 2.2 ACCEPTABLE CONSTRUCTION PRACTICE

SA 2.2
Amdt No. 10

Performance Requirement SA 2.1 is satisfied for a Class 1 building if it achieves a house energy rating of at least 4 Stars when assessed with the Nationwide House Energy Rating Scheme (NatHERS), or FirstRate house energy rating software.

SA 3 - WET AREAS

SA 3.1 PERFORMANCE PROVISIONS

Objective

SA 3.1
Amdt No. 3 As per Section 2 *Objectives* for wet areas.

Functional Statement

As per Section 2 *Functional Statement* for wet areas.

Performance Requirement

Floors in bathrooms, or rooms containing a shower or a sanitary fixture, must be installed in a manner that will prevent accumulation of water on the surface which could create unhealthy or hazardous conditions.

SA 3.2 ACCEPTABLE CONSTRUCTION PRACTICE

SA 3.2.1 Application

SA 3.2
Amdt No. 4 *Performance Requirements* P2.4.1 and SA3.1 are satisfied for wet areas in Class 1 and 10 buildings if they are waterproofed in accordance with Minister's Specification SA F1.7 - Waterproofing of wet areas in buildings.

SAFE MOVEMENT AND ACCESS

SA 4 SWIMMING POOL SAFETY

Limitation:

SA 4 only applies to a *swimming pool* associated with a Class 1 building with a depth of water more than 300 mm.

SA 4.1 PERFORMANCE PROVISIONS

Objective

SA 4.1
Amdt No. 5 As per Section 2 *Objective* O2.5.

Functional Statement

A *swimming pool* must not allow a young child to be entrapped or injured due to suction by pump intakes.

Performance Requirement

Pump intakes to *swimming pools* must have such dimensions and safety protection measures so as to prevent injury to a young child due to entrapment by suction.

SA 4.2 ACCEPTABLE CONSTRUCTION PRACTICE**SA 4.2.1 Application**

Compliance with the acceptable construction practice provisions of SA 4.2.2 for swimming pool pump intakes satisfies *Performance Requirement SA 4.1*.

SA 4.2.2 Pump Intakes

A swimming pool water recirculation and filtration system must comply with AS 1926.3 and have at least two pump intakes not less than 800 mm apart.

SA 5 ACCESS FOR PEOPLE WITH DISABILITIES**Limitation:**

SA 5 applies to Class 1 buildings when a development of 20 or more sole occupancy units is undertaken on an allotment.

SA 5.1 PERFORMANCE PROVISIONS**Objective**

Provide, as far as is reasonable, people with safe, equitable and dignified access to a degree necessary to-

- (a) buildings; and
- (b) the services and facilities within.

Functional Statement

A building to a degree necessary is, as far as is reasonable, to provide safe, equitable and dignified access for people to the services and facilities within.

Performance Requirement

Buildings and immediate surrounds must have appropriate features to a degree necessary to enable people with disabilities to safely and equitably-

- (a) negotiate the route from the road boundary to and within the building using a wheelchair; and
- (b) have access to spaces within the building, including facilities *required* under P2.4.3.

SA 5.2 ACCEPTABLE CONSTRUCTION PRACTICE**SA 5.2.1 Application**

Compliance with the acceptable construction practice provisions of Part SA 5.2 for access for people with disabilities satisfies *Performance Requirement SA 5.1*.

SA Part 5.2 applies to certain Class 1 buildings where access is *required* under Clause SA 5.2.2.

SA 5.2.2 Access to buildings

Whenever 20 or more sole occupancy units including Class 1 buildings are constructed on an allotment, access must be provided to and within one sole occupancy unit or 5% of the sole occupancy units, whichever is the greater.

SA 5.2.3 Parts of buildings to be accessible

- (a) Access for people with disabilities must be provided from the entrance doorway to areas normally used by the occupants. A path of travel providing *required* access must not include a stairway or other impediment which would prevent a person in a wheelchair using it.
- (b) Access, finishes and fittings must comply with the provisions of AS 1428.1.
- (c) In every Class 1 building to which access for people with disabilities is *required*, one closet pan and washbasin and one shower must be provided for use by people with disabilities.

SA 5.2.3(c)
Amdt No. 2

Amdt 11

SA 6 - ACCESS FOR INSPECTION AND MAINTENANCE

SA 6.1 PERFORMANCE PROVISIONS**Objective**

The *Objective* is to safeguard people from injury and illness resulting from the creation of hazardous spaces between buildings.

Functional Statement

The space between buildings must not allow hazardous conditions to arise due to accumulation of rubbish that cannot be readily removed.

Performance Requirement

The space between buildings must be sufficient to allow access for inspection and maintenance to avoid hazardous conditions arising due to accumulation of rubbish that could-

- (a) bridge termite barriers; or
- (b) harbour vermin; or
- (c) create a fire hazard.

SA 6.2 ACCEPTABLE CONSTRUCTION PRACTICE**SA 6.2.1 Application**

Compliance with the acceptable construction provision of SA 6.2 for acceptable separation between buildings for Class 1 and 10 buildings satisfies *Performance Requirement* SA 6.1.

SA 6.2.2 Minimum separation between buildings

Unless the space between external columns is not infilled, every part of an *external wall* of a building must be not less than 600 mm from-

- (a) any boundary of the allotment, unless that wall is on or abutting that boundary; or
- (b) the *external wall* of any other building on the same allotment, unless the two buildings are abutting.

TASMANIA ADDITIONS

Application of Tasmanian variations

This Appendix contains additional provisions for application in Tasmania as follows:

FIRE SAFETY

Limitation:

Tas 1 does not apply to-

1. roof coverings or canopies of PVC, Acrylic, Polycarbonate and GRP sheeting over a balcony, verandah, carport, covered way, swimming pool, barbecue area, or similar open structure attached to a Class 1 building; or
2. Class 1 buildings on land zoned Rural (except Rural Residential) in the Municipality's or City's sealed Planning Scheme, Effective Interim Order, or Special Planning Order if situated at a distance of not less than 30 m from a wooden building or the allotment boundary or not less than 15 m from other buildings; and
3. where, in accordance with 2., a roof is covered with wood shingles or shakes, the shingles or shakes are underlaid with a material having a *Flammability index* not greater than 2.

Limitation
Amdt No. 2

Amdt 11

TAS 1 - NON-COMBUSTIBLE ROOF COVERINGS

TAS 1.1 PERFORMANCE PROVISIONS

Objective

The fire safety *Objective* is to prevent the spread of fire from air-borne embers.

Functional Statement

Protect Class 1 buildings from air-borne embers.

Performance Requirement

A Class 1 building must be protected from the spread of fire from air-borne embers from other property by the provision of a *non-combustible* roof covering.

TAS 1.2 ACCEPTABLE CONSTRUCTION PRACTICE

Tas 1.2.1 Non-combustible roofing

A roof covered with any of the following materials satisfies the *Performance Requirements* of Tas 1.1.

- (a) Metal sheeting or tiles.
- (b) Slates.
- (c) Terracotta or cement roofing tiles.
- (d) Fibre cement sheeting or shingles.
- (e) Asphalt shingles except on buildings with rise in storeys exceeding 2.
- (f) Built-up roofing covered with *non-combustible* material.
- (g) Concrete, granolithic, terrazzo, cement mortar, or other similar *non-combustible* materials.

HEALTH AND AMENITY

TAS 2 - SWIMMING POOL WATER RETICULATION AND FILTRATION

Limitation:

Tas 2 does not apply to a *swimming pool* associated with a Class 1 building if the depth of water is less than 300 mm and the volume of the pool does not exceed 15 m³.

TAS 2.1 PERFORMANCE PROVISIONS

Objective

The *objective* is to safeguard people from illness or injury arising from the use of a *swimming pool*.

Functional Statement

Swimming pools must provide for the health and safety of swimmers and others.

Performance Requirement

Swimming pools must be provided with an adequate water recirculation, disinfection and filtration system which is suitable and safe to use.

TAS 2.2 ACCEPTABLE CONSTRUCTION PRACTICE

Tas 2.2.1 Application

Compliance with the provisions of Tas 2.2 for a *swimming pool* associated with a Class 1 building with a depth of water more than 300 mm and volume exceeding 15 m³ satisfies *Performance Requirement* Tas 2.1.

Tas 2.2.2 Water recirculation and filtration system

A water recirculation, disinfection and filtration system in a *swimming pool* must provide for-

- (a) the inlet and outlet openings for the purpose of water recirculation to be so located that water movement is continuous from inlet to outlet; and
- (b) the inlet and outlet openings, and skimmer boxes where provided, to comply with AS 1926.3; and
- (c) the recirculation of water to be so designed that the pool contents are recirculated not less than once-
 - (i) in 6 hours for an outdoor *swimming pool*; or
 - (ii) in 4 hours for an indoor *swimming pool*; and
- (d) the water filtration rates to not exceed 12 250 L/m² of sand filter bed per hour, or an equivalent rate in other filter media.

VICTORIA ADDITIONS

Application of Victorian variations

This Appendix contains additional provisions for application in Victoria as follows:

HEALTH AND AMENITY

VIC 1 ENERGY EFFICIENCY

Limitation:

VIC 1 applies to Class 1 buildings only.

Amdt 11

VIC 1.1 PERFORMANCE PROVISIONS

Vic 1.1
Amdt No. 4

Objective

The *Objective* of this Part is to facilitate efficient use of energy in a building.

Functional Statement

A building is to be designed to achieve efficient use of energy for internal heating or cooling.

Performance Requirement

A building must have an adequate level of thermal performance to ensure efficient use of energy for internal heating and cooling.

VIC 1.2 ACCEPTABLE CONSTRUCTION PRACTICE

Vic 1.2.0 Definitions

The following definition is used in this Part:

R or **R value** means the thermal resistance of an element of the building measured in m²K/W.

Vic 1.2.1 Application

Compliance with the provisions of Vic Part 1.2 for thermal insulation in Class 1 buildings satisfies *Performance Requirement* Vic 1.1.

Vic 1.2.2 Exemption

Vic 1.2.3(a) does not apply to-

- (a) concrete panels, cavity brick, earth wall construction, ashlar stone or other masonry walls which have a thickness (excluding any cavity) of not less than 180 mm if the floor of the building is concrete or masonry in direct contact with the ground; or
- (b) windows, vents and other similar openings in walls, roofs and ceilings.

Vic 1.2.3 Provision of thermal insulation

Vic 1.2.3
Amdt No. 10

- (a) The building must-
 - (i) for the elements nominated in Vic Table 1, comply with all the *R Values* of option A or all the *R Values* of option B; or
 - (ii) achieve a house energy rating of at least 3 stars and at least equivalent to that which would be achieved using option A or B of Vic Table 1, as assessed by-
 - (A) a registered building practitioner accredited in the use of Sustainable Energy Authority Victoria's FirstRate house energy rating software; or
 - (B) Sustainable Energy Authority Victoria.

Vic Table 1
Amdt No. 4

Vic Table 1 MINIMUM OVERALL R VALUES		
Element	Option A	Option B
Roof or ceiling	R2.2	R2.2
External wall	R1.3	R1.7
Ground Floor	R1.0	R0.7
Note:	For the purposes of this Table, a wall which separates a Class 1 building from a Class 10a building or from any roof space is regarded as an <i>external wall</i> .	

- (b) **Deemed R Value** - An element described in Vic Table 2 is deemed to have the *R value* nominated in the Table adjacent to the description of the element.

Vic Table 2
Amdt No. 8

Vic Table 2 R VALUES FOR COMMON ELEMENTS	
Description of element	R value
Roofs or ceilings	
Tiled or metal pitched roof, R2.5 bulk insulation between ceiling joists, lined ceiling	R2.4
Tiled or metal pitched roof, rfl as sarking and insulation over rafters, R2.0 bulk insulation between ceiling joists, lined ceiling	R2.2

Vic Table 2	
R VALUES FOR COMMON ELEMENTS (Continued)	
Description of element	R value
Metal deck roof, R2.0 bulk insulation installed between rafters, rfl as a vapour barrier, ceiling lining on underside of rafters	R2.2
Metal deck roof, R2.0 bulk insulation installed between roof battens, rfl as a vapour barrier, ceiling lining on top of exposed rafters	R2.2
Tiled roof, rfl as sarking and insulation, R2.0 bulk insulation installed between counter battens, optional rfl as a vapour barrier, ceiling lining on top of exposed rafters	R2.2
External walls	
Brick/masonry veneer with R1.5 bulk insulation between the studs, lined internally	R1.7
Brick/masonry veneer with R1.0 foam board fixed over the face of the studs, lined internally	R1.7
Brick/masonry veneer with double-sided rfl fixed to external face of studs, lined internally	R1.3
Weatherboard/fibre cement cladding, R1.5 bulk insulation between studs, lined internally	R1.7
Weatherboard/fibre-cement, double-sided perforated rfl dished between studs lined internally	R1.3
Cavity brick with R0.8 foam board in cavity	R1.3
150 mm concrete panel with R1.0 foam board and lined internally	R1.3
Floors	
Concrete/masonry on ground	R1.5
Timber framed floor, enclosed perimeter	R1.0
Timber framed floor, unenclosed perimeter, 20 mm foam board fixed to the underside of floor joists	R1.0
Timber framed floor, unenclosed perimeter, perforated rfl dished between joists	R1.0
Timber framed floor unenclosed perimeter	R0.7
Note: For the purposes of this Table an enclosed perimeter may incorporate sub-floor ventilation at the rate of approximately 7300 mm ² /m.	

Amdt 11

Vic 1.2.4 Chimneys and flues

Chimneys and flues from open solid fuel-burning appliances must be provided with a damper or flap.

Vic 1.2.5 Installation of reflective foil laminate

Installation of reflective foil laminate (rfl) must comply with AS/NZS 4200.2.

SPECIAL REQUIREMENTS FOR CERTAIN BUILDINGS AND COMPONENTS

In addition to any applicable provisions of the Building Act 1993, the Building Regulations 1994 and *Housing Provisions*, there are a number of technical building design and construction requirements of which practitioners should be aware. The following is a list of some of these:

1. **Accommodation - Residential (boarding houses, guest houses, hostels)**
 - 1.1 Approval authority: Municipal council
 - 1.2 Relevant legislation: Health Act 1958, Health (Prescribed Accommodation) Regulations 2001
2. **Alpine Resorts - approval of construction**
 - 2.1 Approval authority: Alpine Resorts Commission
 - 2.2 Relevant legislation: Alpine Resorts Act 1983, Alpine Resorts (Management) Act 1997
3. **Crown land - construction approval**
 - 3.1 Approval authority: Crown Land and Assets Division, Department of Natural Resources and Environment
 - 3.2 Relevant legislation: Crown Land (Reserves) Act 1978
4. **Electrical installations**
 - 4.1 Authority: Electricity supply companies
 - 4.2 Relevant legislation: Electricity Industry Act 2000, State Electricity Commission Act 1958, Electricity Safety Act 1998, Electricity Safety (Installation) Regulations 1999
 - 4.3 Design codes: SAA Wiring Rules, AS/NZS 3000/3013
5. **Fences (dividing)**
 - 5.1 Relevant legislation: Fences Act 1968
 - 5.2 Appeal body: Magistrates' Court
6. **Fire prevention in existing buildings**
 - 6.1 Authority: Municipal council
 - 6.2 Relevant legislation: Building Act 1993, Building Regulations 1994, Health Act 1958
 - 6.3 Appeal body: Building Appeals Board (Building Act only)
7. **Gas installations**
 - 7.1 Approval authority: Gas and Fuel (Gascor)
 - 7.2 Relevant legislation: Gas Industry Act 2001, Gas Safety Act 1997, Gas Safety (Gas Installation) Regulations 1999
 - 7.3 Design codes: Gas Installation Code AG601 1992
8. **Historic buildings**
 - 8.1 Approval authority: Executive Director under the Heritage Act 1995
 - 8.2 Relevant legislation: Heritage Act 1995
 - 8.3 Appeal body: Heritage Council

Amdt 11

9. Movable dwellings (in caravan parks)

9.1 Approval authority: Municipal council

Vic 9.2
Amdt No. 10

9.2 Relevant legislation: Residential Tenancies Act 1997; Residential Tenancies (Caravan Parks and Movable Dwellings Registration and Standards) Regulations 1999.

9.3 Appeals body: Building Appeals Board

10. Occupational health and safety

10.1 Approval authority: Victorian WorkCover Authority

Vic 10.2
Amdt No. 5

10.2 Relevant legislation: Occupational Health and Safety Act 1985, Occupational Health and Safety (Asbestos) Regulations 1992, Health Act 1958.

10.3 Design Codes: Various Codes of practice published by the Authority

11. Planning controls

11.1 Approval authority: Municipal council, in some cases the Minister for Planning

Vic 11.1
Amdt No. 10

11.2 Relevant legislation: Planning and Environment Act 1987

Vic 11.4
Amdt No. 4

11.3 Design codes: Planning schemes

11.4 Appeal body: Victorian Civil and Administrative Tribunal

12. Sanitary plumbing, water supply and sewerage

12.1 Approval authority: Melbourne Water in metropolitan area, sewerage and water supply authorities in country areas

Vic 12.2 &
12.3
Amdt No. 10

12.2 Relevant legislation: Water Industry Act 1994, Water Act 1989, Plumbing Regulations 1998

12.3 Design codes: AS/NZS 3500 National Plumbing and Drainage Code

13. Septic tank installations

13.1 Approval authority: Municipal council, Environment Protection Authority (discharge > 5000 l/day)

13.2 Relevant legislation: Environment Protection Act 1970

13.3 Design codes: Septic Tanks Code of Practice 1990

14. Subdivision of buildings

14.1 Approval authority: Municipal Council

14.2 Relevant legislation: Subdivision Act 1988

Amdt 11

WESTERN AUSTRALIA ADDITIONS

Western Australia has no additions to the Housing Provisions.

Amdt 11

INDEX ABBREVIATIONS AND SYMBOLS

Index	55,011
Abbreviations and Symbols	55,101

INDEX (TO DEEMED TO SATISFY PROVISIONS)

A

Adoption of Standards and other references: 1.1.2

Air-handling systems, ventilation of rooms: 3.8.5

Airlocks: 3.8.5.3

ceiling heights: 3.8.2

Alarm systems, smoke detection and alarm systems: 3.7.2

Alpine area, definition: 1.1.1.2

fire safety construction: 3.7.5

Alteration, definition: 1.1.1.2

Aluminium Structures Code: 3.11.4

Amenity and health: Part 3.8

Application of the BCA, general: 1.0

to a particular State or Territory: 1.1.6

Appropriate authority, definition: 1.1.1.2

Articulate masonry, definition: 3.2

articulate joints: 3.3.1.8

Artificial lighting: 3.8.4.3

Automatic, definition: 1.1.1.2

Average recurrence interval, definition: 1.1.1.2

B

Balconies, barriers: 3.9.2

Balustrades: 3.9.2

Barrier, termite: 3.1.3

handrail, balustrade: 3.9.2

Bathroom, ceiling height: 3.8.2

walls, sound insulation: 3.8.6

waterproofing: 3.8.1

Baths, required facilities: 3.8.3

waterproofing: 3.8.1

Bedrooms, natural light: 3.8.4

-
- Bracing**, masonry walls: 3.3.2.1
- Brick ties**: 3.3.3
- Building classifications**: 1.3
- Bushfire prone areas**, construction: 3.7.4
- C**
- Ceiling heights**: 3.8.2
- Cellulose fibre reinforced cement roofing**: 3.5.1
- Certificate of Accreditation**, definition: 1.1.1.2
- Chimneys**, flues, fireplaces, heating appliances: 3.7.3
- Cladding**, roof and wall: 3.5
- Class 1 buildings**, classification: 1.3
- sanitary facilities: 3.8.3
 - Type of fire-resisting construction required: 3.7.1
- Classification**, of buildings: 1.3
- principles: 1.3.1
 - multiple: Type of construction: 1.3.3
- Closet pans**, sanitary facilities: 3.8.3
- location, 3.8.5
- Clothes washing facilities**, 3.8.3
- Combustible**, definition: 1.1.1.2
- Common wall**, definition: 1.1.1.2
- Composite steel and concrete**, construction: 3.11
- Concrete**: 3.2.3
- Concrete roofing tiles**, installation: 3.5.1
- Concrete structures**, construction: 3.11
- Controlled Fill**, definition: 3.2
- Corridor**, ceiling height: 3.8.2
- Corrosion protection**, wall ties: 3.3.3.2
- steel lintels: 3.4.4
 - steel framing: 3.4.2.2
 - metal roofing systems: 3.5.1.3

Cyclonic areas, location: 3.10.1

D

Damp and weatherproofing, performance provisions: 2.2

Damp-proof course (DPC), definition: 1.1.1.2

Installation requirements: 3.3.4

Damp-proofing, floors on ground: 3.2.2

Dampness, on building site: 3.1.1

weatherproofing: 3.3.4

Design suitability: 1.2.2

Design wind speed, definition: 1.1.1.2

Designated bushfire prone area, definition: 1.1.1.2

Domestic-type heating appliances: 3.7.3

Downpipes, 3.5.2

Drainage, stormwater: 3.1.2

roofs, 3.5.2

E

Early Fire Hazard Indices: roof sarking 3.7.1

determination: 1.2.4

Earthquake areas, location: 3.10.2

construction requirements: 3.10.2

Earthquake load, structural requirements: 3.10.2 and 3.11

Earthwall construction, structural provisions: 3.3.5

Earthworks: 3.1.1

Evidence of suitability of materials, form of construction or design: 1.2.2

Excavation, vacant adjoining property: 3.1.1.2

existing buildings: 3.1.1.3

for drains: 3.1.2.2

for footings: 3.2.2.1

Exhaust ventilation, closet pan, urinal: 3.8.5

kitchen local exhaust ventilation: 3.8.5

Exit, in alpine areas: 3.7.5

-
- Explanatory information**, use of: 1.1.8
- External stairways**: 3.9.1
- External wall**, definition: 1.1.1.2
- fire-resistance Class 1 and 10 buildings: 3.7.1
 - protection of openings: 3.7.1
- F**
- Facilities**, sanitary and other: 3.8.3
- Fencing**, swimming pools: 3.9.3
- Fibre reinforced cement**, roof sheeting, installation: 3.5.1
- Fill**, earthworks: 3.1.1.4
- under slabs: 3.2.2.2
- Finished ground level**, definition: 3.2
- surface water drainage: 3.1.2.3
- Fire and smoke**, alarms: 3.7.2
- Fire safety**, performance provisions: 2.3
- Fire separation**: 3.7.1
- Fireplaces**, masonry construction: 3.3.1
- footings, 3.2.5
 - heating appliances, chimneys and flues: 3.7.3
- Fire-resistance**, separating walls: 3.7.1
- external walls: 3.7.1
 - masonry-veneer walls: 3.7.1
 - roofs: 3.7.1
 - of building elements: 1.2.3
- Fire-Resistance Level**, definition: 1.1.1.2
- external walls: 3.7.1
- Fire-resisting**, definition: 1.1.1.2
- Fire-resisting construction**, definition: 1.1.1.2
- acceptable walls, 3.7.1
- Fire-source feature**, definition: 1.1.1.2
- diagram 2.3
- Fire windows**, protection of openings: C3.4
- construction: Spec C3.4

Flammability Index, definition: 1.1.1.2

sarking type materials: 3.7.1

Flashings, definition: 1.1.1.2

Installation requirements: 3.3.4

sheet metal roofs: 3.5.1.3

openings in wall cladding: 3.5.3.6

Floor area, definition: 1.1.1.2

Floors, on ground, damp-proofing: 3.2.2

timber, sub-floor ventilation: 3.4.1

Flues, chimneys, fireplaces, heating appliances: 3.7.3

Footings: 3.2

construction: 3.2.5

Foundation, definition: 1.1.1.2

allowable bearing pressure: 3.2.2.3

Framing, steel: 3.4.2

timber: 3.4.3

G

Garage, private, definition: 1.1.1.2

weatherproofing, masonry: 3.3.4

Glass, installation: 3.6

GRP sheeting, roof construction: 3.5.1

Gutters, roof drainage: 3.5.2

H

Habitable room, definition: 1.1.1.2

ceiling height: 3.8.2

natural light: 3.8.4

walls, sound insulation: 3.8.6

Handrails, construction: 3.9.2

Health and amenity: Part 3.8

performance provisions: 2.4

Hearth, construction of fireplaces: 3.7.3

Heating appliances, fireplaces, chimneys and flues: 3.7.3

Height of rooms: 3.8.2

High wind area, definition: 1.1.1.2

Housing Provisions, definition: 1.1.1.2

I

Illuminance, definition: 1.1.1.2

Impact sound, acceptable construction, 3.8.6

Imposed actions, structural requirements: 3.11

Insulation, fire-resistance level, definition: 1.1.1.2

Insulation, sound: Part 3.8.6

Integrity, fire-resistance level, definition: 1.1.1.2

Internal wall, definition: 1.1.1.2

Interpretation, of diagrams: 1.1.7

J

K

Kitchen, ceiling height: 3.8.2

 local exhaust ventilation: 3.8.5

 sinks, sanitary and other facilities: 3.8.3

 walls, sound insulation: 3.8.6

L

Ladders: access to storerooms, 3.9.1

Land, drainage: 3.1.1

Language: 1.1.7

Landings, balustrades: 3.9.2

 dimensions and construction: 3.9.2

 stairways: 3.9.1

Latches, door, operation for swimming pool access: 3.9.3

Lateral support, definition: 3.3

Laundry, ceiling height: 3.8.2

 walls, sound insulation: 3.8.6

 waterproofing: 3.8.1

Light, artificial: 3.8.4.3

 natural: 3.8.4.2

Lightweight construction, definition: 1.1.1.2

Lintels, masonry: 3.3.3, 3.3.2.2
structural steel beams 3.4.4

Loadbearing, definition: 1.1.1.2

Loadbearing wall, definition: 3.2

Loads, structural requirements: 3.11

M

Maintenance of smoke alarms: 3.7.2

Masonry, 3.3

units: 3.3.1.5

accessories: 3.3.3

Masonry-veneer walls, fire-resistance: 3.7.1

external walls: 3.3.1.2

Materials, structural requirements: 3.11

suitability: 1.2.1

Mechanical ventilation, air locks: 3.8.5

kitchen local exhaust: 3.8.5

rooms: 3.8.5

Metal roofing, installation: 3.5.2

Moisture barriers, floor on ground: 3.2.2.6

Mortar, mixes: 3.3.1.6

joints: 3.3.1.7

Multiple classifications: 1.3.3

N

Natural light: 3.8.4

borrowed: 3.8.4

Natural ventilation: 3.8.5

borrowed: 3.8.5

Noise transmission: see 'sound transmission'

Non-combustible, definition: 1.1.1.2

materials: 3.7.1

O

Oil-fired appliances, 3.7.3

Open fireplaces, construction: 3.7.3

Openings, in external walls 3.7.1
Other property, definition: 1.1.1.2
Outdoor air, definition: 1.1.1.2
Outfall, drainage system, definition: 1.1.1.2

P

Passageway, ceiling height: 3.8.2
Permanent actions, structural requirements: 3.11
Piling, construction: 3.2.1
Pipes, soil and waste, sound insulation: 3.8.6
Pools, swimming: 3.9.3
Principles of classification: 1.3
Private garage, definition: 1.1.1.2
Professional engineer, definition: 1.1.1.2
Protection of openings: in Class 1 buildings, 3.7.1
PVC sheeting, roof construction: 3.5.1
 roof lights: 3.7.1

Q

R

Referenced Standards: 1.4
Registered Testing Authority, definition: 1.1.1.2
Reinforcing, concrete: 3.2.3
Reinforced masonry: 3.3.2
Required, definition: 1.1.1.2
Risers and treads, dimensions: 3.9.1
Roof, construction - frame: 3.4
 coverings: 3.5.1 and 3.5.2
 fire-resistance: 3.7.1
 sarking: 3.7.1
Roof lights: 3.7.1
Roof tiles: 3.5.1.2
Room height: 3.8.2

S

Safe movement and access, performance provisions: 2.5

Safety fencing, swimming pools: 3.9.3

Sanitary compartment, definition: 1.1.1.2

waterproofing: 3.8.1

Sanitary and other facilities: 3.8.3

Sarking, roof, fire proofing: 3.7.1

installation: 3.5.1

Sarking-type material, definition: 1.1.1.2

Early Fire Hazard Indices: 3.7.1

Self closing, door or window, definition: 1.1.1.2

Separating wall, definition: 1.1.1.2

fire resistant level: 3.7.1

Separation, by separating walls: 3.7.1

Shower enclosures, waterproofing: 3.8.1

Showers, requirements: 3.8.3

Site, definition: 1.1.1.2

dampness: 3.1.1

earthworks: 3.1.1

drainage: 3.1.2

classification: 3.2.4

Sitework, definition: 1.1.1.2

Slabs: 3.2

construction: 3.2.5

Smoke alarms: 3.7.2

Smoke-Developed Index, definition: 1.1.1.2

Snow, areas, fire safety construction: 3.7.5

load, structural requirements: 3.11

Soil and waste pipes, sound insulation: 3.8.6

Soil treatment, against termites: 3.1.3

Solid-fuel burning appliances, domestic-type: 3.7.3

Sound insulation, impact, test of equivalence: 3.8.6

walls between buildings: 3.8.6

waste and soil pipes: 3.8.6.4

-
- Sound transmission and insulation:** 3.8.6
- Spread-of-Flame Index**, definition: 1.1.1.2
- Stair**, dimensions, treads and risers: 3.9.1
- Stairway**, landings, construction: 3.9.1
- Standard Fire Test**, definition: 1.1.1.2
- Standards**, adoption: 1.1.2, 1.1.3, 1.4
- STC**, see weighted sound reduction index
- Steel**, construction: 3.4.2 and 3.4.4
- floor framing: 3.4.2.3
 - wall framing: 3.4.2.4
 - roof framing: 3.4.2.5
- Stormwater drainage:** 3.1.2, 3.5.2
- Structural adequacy**, Fire-Resistance Level, definition: 1.1.1.2
- Structural member**, definition: 1.1.1.2
- Structural Provisions:** 3.11
- Structural steel members**, 3.4.4
- Structures**, trafficable, alpine areas: 3.7.5
- Sub-floor ventilation:** 3.4.1
- Subsoil drainage:** 3.1.2
- Suitability of materials**, construction or design: 1.2.1
- Surface water**, definition: 1.1.1.2
- drainage: 3.1.2.3
- Swimming pool**, definition: 1.1.1.2
- requirements: 3.9.3
- T**
- Termite shields**, damp-proof course: 3.3.4
- Termite risk management:** 3.1.3
- Terracotta**, roof tiles, installation: 3.5.1
- weatherproofing: 3.5.4

Tilt-up construction, external walls - concrete construction: 3.11

Timber, construction: 3.4.3

 floors, sub-floor ventilation: 3.4.1

Treads and risers, dimensions: 3.9.1

Truss connections, to masonry: 3.3.2.2

U

Unreinforced masonry: 3.3.1

V

Vapour barriers, floor on ground: 3.2.2

Ventilation, exhaust: 3.8.5

 natural: 3.8.5

 of rooms: 3.8.5

 sub-floor: 3.4.1, 3.3.1.9

W

Wall cladding: 3.5.3

Wall ties: 3.3.3

Walls, between units, sound insulation: 3.8.6

Washbasins, requirements: 3.8.3

Waste and soil pipes, sound insulation: 3.8.6

Water closets, restricted location: 3.8.5

 waterproofing: 3.8.1

Water resistant materials, wet areas in buildings: 3.8.1

Waterproofing: 3.3.4

 dampness slab-on-ground: 3.2.3

 of roofs and walls: 3.5

Weep holes, protection of openings, in bushfire areas: 3.7.4

Weighted sound reduction index, interpretation: 3.8.6

Wet areas, in buildings, waterproofing: 3.8.1

Wind load, structural requirements: 3.11

Window, definition: 1.1.1.2

 methods of protection of openings: 3.7.1

 natural light: 3.8.4

X

Y

Z

Amdt 11

ABBREVIATIONS AND SYMBOLS

Abbreviations and Symbols used in the *Housing Provisions* include:

ABBREVIATIONS

ABCB	Australian Building Codes Board
AISC	Australian Institute of Steel Construction
ALGA	Australian Local Government Association
AS	Australian Standard
ASTM	American Society for Testing and Materials
BCA	Building Code of Australia
BCC	Building Codes Committee
CSIRO	Commonwealth Scientific and Industrial Research Organisation
DBC&E	CSIRO Division of Building, Construction and Engineering
FRL	Fire Resistance Level
GRP	glass fibre reinforced polyester
ISO	International Organisation for Standardisation
NATA	National Association of Testing Authorities
NBTC	CSIRO National Building Technology Centre
PVC	polyvinyl chloride
R _w	Weighted Sound Reduction Index
STC	Sound Transmission Class
SSL	Scientific Services Laboratory
UPVC	unplasticised polyvinyl chloride

SYMBOLS AND SI UNITS

°C - degree(s) Celsius	m - metre(s)
K - kelvin(s)	m ² - square metre(s)
kg - kilogram(s)	m ³ - cubic metre(s)
kg/m - kilogram(s) per metre	m/s - metre(s) per second
kg/m ² - kilogram(s) per square metre	m ³ /s - cubic metre(s) per second
kg/m ³ - kilogram(s) per cubic metre	mm - millimetre(s)
km - kilometre	mm ² - square millimetre(s)
kPa - kilopascal(s)	um - micrometer
kW/m ² - kilowatt(s) per square metre	MW - megawatt(s)
L - litre(s)	N - newton(s)
L/s - litre(s) per second	MPa - megapascal(s)
L/s.m ² - litre(s) per second square metre	> - greater than
lx - lux	< - less than
∅ - diameter	≤ - equal to or less than
F - in relation to steel members means steel fabric	≥ - equal to or more than

HISTORY OF AMENDMENTS

HISTORY CONTENTS

		Page
History of amendments		57,021
1.0	Adoption of BCA 96	
1.1	Amendment No. 1	
1.2	Amendment No. 2	
1.3	Amendment No. 3	
1.4	Amendment No. 4	
1.5	Amendment No. 5	
1.6	Amendment No. 6	
1.7	Amendment No. 7	
1.8	Amendment No. 8	
1.9	Amendment No. 9	
1.10	Amendment No. 10	
1.11	Amendment No. 11	

Amdt 11

HISTORY OF AMENDMENTS

1.0 Adoption of BCA96

The 1996 edition of the BCA was adopted by the Commonwealth, States and Territories as set out in Table 1.0.

Table 1.0
Amdt No. 3

Table 1.0	
History of adoption of BCA96	
Administration	Adoption Date
Commonwealth	1 July 1997
Australian Capital Territory	1 July 1997
New South Wales	1 July 1997
Northern Territory	7 January 1998
Queensland	1 July 1997
South Australia	1 January 1998
Tasmania	1 July 1997
Victoria	1 August 1997
Western Australia	1 July 1997

Amdt 11

1.1 Amendment No. 1

(a) Amendment No. 1 of the 1996 edition of the BCA was adopted by the Commonwealth, States and Territories as set out in Table 1.1.

Table 1.1
Amdt No. 3

Table 1.1	
History of adoption of Amendment No. 1 of BCA96	
Administration	Adoption Date
Commonwealth	1 July 1997
Australian Capital Territory	1 July 1997
New South Wales	1 July 1997
Northern Territory	7 January 1998
Queensland	1 July 1997
South Australia	1 January 1998
Tasmania	1 July 1997
Victoria	1 August 1997
Western Australia	1 July 1997

- (b) The purpose of Amendment No. 1 is to—
 - (i) include typographical changes including spelling, punctuation, cross references and layout; and
 - (ii) include reference to a *Certificate of Conformity* issued by the ABCB in A2.2; and
 - (iii) change the reference to the Standards Mark Certificate to refer to JAS-ANZ in A2.2; and
 - (iv) update references to Standards.

Note: The revisions contained in Amendment No. 1 to the *Housing Provisions* have not been marked in the text.

1.2 Amendment No. 2

- (a) Amendment No. 2 of the 1996 edition of the BCA was adopted by the Commonwealth, States and Territories as set out in Table 1.2.

Table 1.2
Amdt No. 3

Table 1.2	
History of adoption of Amendment No. 2 of BCA96	
Administration	Adoption Date
Commonwealth	1 January 1998
Australian Capital Territory	1 January 1998
New South Wales	27 February 1998
Northern Territory	7 January 1998
Queensland	1 January 1998
South Australia	1 January 1998
Tasmania	1 January 1998
Victoria	1 January 1998
Western Australia	1 January 1998

- (b) The purpose of Amendment No. 2 is to -
 - (i) include typographical changes including spelling, punctuation, cross references and layout; and
 - (ii) update references to Standards; and
 - (iii) include minor technical changes.

1.3 Amendment No. 3

1.3
Amdt No. 4

- (a) Amendment No. 3 of the 1996 edition of the BCA was adopted by the Commonwealth, States and Territories as set out in Table 1.3.

Administration	Adoption Date
Commonwealth	1 July 1998
Australian Capital Territory	1 July 1998
New South Wales	1 July 1998
Northern Territory	1 July 1998
Queensland	1 July 1998
South Australia	13 July 1998
Tasmania	1 July 1998
Victoria	1 July 1998
Western Australia	1 July 1998

Amdt 11

- (b) The purpose of Amendment No. 3 is to -
- (i) incorporate the outcomes of the 1997 ABCB Variations Conference; and
 - (ii) update references to Standards; and
 - (iii) include minor technical changes.

1.4 Amendment No. 4

1.4
Amdt No. 6

- (a) Amendment No. 4 of the 1996 edition of the BCA was adopted by the Commonwealth, States and Territories as set out in Table 1.4.

Administration	Adoption Date
Commonwealth	1 January 1999
Australian Capital Territory	17 May 1999
New South Wales	1 February 1999
Northern Territory	1 January 1999
Queensland	1 January 1999
South Australia	1 January 1999
Tasmania	1 January 1999
Victoria	1 January 1999
Western Australia	1 January 1999

- (b) The purpose of Amendment No. 4 is to -
- (i) update references to standards; and
 - (ii) include minor technical changes.

Amdt 11

1.5 Amendment No. 5

1.5
Amdt No. 7

- (a) Amendment No. 5 of the 1996 edition of the BCA was adopted by the Commonwealth, States and Territories as set out in Table 1.5.

Table 1.5	
History of adoption of Amendment No. 5 of BCA96	
Administration	Adoption Date
Commonwealth	1 July 1999
Australian Capital Territory	3 November 1999
New South Wales	1 August 1999
Northern Territory	1 July 1999
Queensland	1 July 1999
South Australia	1 July 1999
Tasmania	1 July 1999
Victoria	1 July 1999
Western Australia	1 July 1999

Amdt 11

- (b) The purpose of Amendment No. 5 is to -
- (i) update references to standards; and
 - (ii) expand on the requirements for sub-floor ventilation based on climatic conditions; and
 - (iii) revise the Acceptable Construction Practice for Steel framing; and
 - (iv) include additional details in the Acceptable Construction Practice for fencing of swimming pools; and
 - (v) include minor technical changes.

1.6 Amendment No. 6

1.6
Amdt No. 8

- (a) Amendment No. 6 of the 1996 edition of the BCA was adopted by the Commonwealth, States and Territories as set out in Table 1.6.

Table 1.6	
History of adoption of Amendment No. 6 of BCA96	
Administration	Adoption Date
Commonwealth	1 January 2000
Australian Capital Territory	10 February 2000
New South Wales	1 January 2000
Northern Territory	1 January 2000
Queensland	1 January 2000
South Australia	17 January 2000
Tasmania	1 January 2000
Victoria	1 January 2000
Western Australia	1 January 2000

- (b) The purpose of Amendment No. 6 is to -
- (i) update references to standards; and
 - (ii) revise the Acceptable Construction Practice for Footing and Slab Construction; and
 - (iii) replace Sound Transmission Class (STC) with weighted sound reduction index (R_w) within Part 3.8.6; and
 - (iv) include minor technical changes.

Amdt 11

1.7 Amendment No. 7

1.7
Amdt No. 8

- (a) Amendment No. 7 of the 1996 edition of the BCA was adopted by the Commonwealth, States and Territories as set out in Table 1.7.

Administration	Adoption Date
Commonwealth	1 July 2000
Australian Capital Territory	10 July 2000
New South Wales	1 July 2000
Northern Territory	1 July 2000
Queensland	1 July 2000
South Australia	1 July 2000
Tasmania	1 July 2000
Victoria	1 July 2000
Western Australia	1 July 2000

Amdt 11

- (b) The purpose of Amendment No. 7 is to -
- (i) update references to standards; and
 - (ii) include requirements for separation of eaves and verandah spaces that are open to the roof space and common to 2 or more Class 1 buildings; and
 - (iii) reinstate the Acceptable Construction Practice for buildings in bushfire-prone areas, following alignment with the 1999 version of AS 3959; and
 - (iv) change the limitations on winders used in lieu of quarter and half landings within stairways; and
 - (v) include minor technical changes.

1.8 Amendment No. 8

1.8
Amdt No. 9

- (a) Amendment No. 8 of the 1996 edition of the BCA was adopted by the Commonwealth, States and Territories as set out in Table 1.8.

Administration	Adoption Date
Commonwealth	1 January 2001
Australian Capital Territory	11 January 2001
New South Wales	1 January 2001
Northern Territory	1 January 2001
Queensland	1 January 2001
South Australia	1 January 2001
Tasmania	1 January 2001
Victoria	1 January 2001
Western Australia	1 January 2001

- (b) The purpose of Amendment No. 8 is to -
- (i) update references to standards; and
 - (ii) include minor technical changes; and
 - (iii) achieve greater consistency between both Volumes of the BCA for stair construction.

Amdt 11

1.9 Amendment No. 9

1.9
Amdt No. 10

- (a) Amendment No. 9 of the 1996 edition of the BCA was adopted by the Commonwealth, States and Territories as set out in Table 1.9.

Administration	Adoption Date
Commonwealth	1 July 2001
Australian Capital Territory	12 July 2001
New South Wales	1 July 2001
Northern Territory	1 July 2001
Queensland	1 July 2001
South Australia	2 July 2001
Tasmania	1 July 2001
Victoria	1 July 2001
Western Australia	1 July 2001

Amdt 11

- (b) The purpose of Amendment No. 9 is to -
- (i) update references to standards; and
 - (ii) include minor technical changes; and
 - (iii) clarify which glazing assemblies must comply with AS 2047 and which must comply with AS 1288.

1.10 Amendment No. 10

1.10
Amdt No. 11

- (a) Amendment No. 10 of the 1996 edition of the BCA was adopted by the Commonwealth, States and Territories as set out in Table 1.10.

Administration	Adoption Date
Commonwealth	1 January 2002
Australian Capital Territory	1 January 2002
New South Wales	1 January 2002
Northern Territory	1 January 2002
Queensland	1 January 2002
South Australia	1 January 2002 (except SA2 - date to be advised)
Tasmania	1 January 2002
Victoria	1 January 2002
Western Australia	1 January 2002

- (b) The purpose of Amendment No. 10 is to -
- (i) update references to standards; and
 - (ii) update the requirements for protective coatings for steelwork in locations near saltwater; and
 - (iii) align Figure 3.6.1 dealing with glazing with AS 1288; and
 - (iv) extend the concession for fire separation of windows in non-habitable rooms to windows in bathrooms, laundries and toilets and also include buildings on the same allotment; and
 - (v) replace testing to AS/NZS 1530.3 for timber in bushfire areas with reference to AS/NZS 3837; and
 - (vi) include minor technical changes.

Amdt 11

1.11 Amendment No. 11

1.11
Amdt No. 11

- (a) Amendment No. 11 of the 1996 edition of the BCA was adopted by the Commonwealth, States and Territories as set out in Table 1.11.

Table 1.11	
History of adoption of Amendment No. 11 of BCA96	
Administration	Adoption Date
Commonwealth	1 July 2002
Australian Capital Territory	1 July 2002 (except Australian Capital Territory additions - date to be advised)
New South Wales	1 July 2002
Northern Territory	1 July 2002
Queensland	1 July 2002
South Australia	1 July 2002
Tasmania	1 July 2002
Victoria	1 July 2002
Western Australia	1 July 2002

Amdt 11

- (b) The purpose of Amendment No. 11 is to -
- (i) update references to standards; and
 - (ii) transfer public policy matters, with respect to structural adequacy, from the AS 1170 series to the BCA; and
 - (iii) introduce new definitions and more detailed provisions on the installation of *flashings* and *damp-proof courses*; and
 - (iv) include minor technical changes.