



Guide to Volume One



2019

Introduction

General Table of Contents

Copyright and licence notice

Introduction

General Table of Contents

Introduction	
Copyright and licence notice	5
Introduction	6
Section A Governing Provisions	
Part A0 *****	9
Section B Structure	
Part B1 Structural provisions	12
Section C Fire resistance	
Section C Fire resistance	24
Part C1 Fire resistance and stability	33
Part C2 Compartmentation and separation	46
Part C3 Protection of openings	65
Section D Access and egress	
Section D Access and egress	116
Part D1 Provision for escape	122
Part D2 Construction of exits	155
Part D3 Access for people with a disability	181
Section E Services and equipment	
Part E1 Fire fighting equipment.....	194
Part E2 Smoke hazard management	210
Part E3 Lift installations	231
Part E4 Visibility in an emergency, exit signs and warning systems.....	237
Section F Health and amenity	
Part F1 Damp and weatherproofing	253
Part F2 Sanitary and other facilities	264
Part F3 Room heights.....	276
Part F4 Light and ventilation.....	279
Part F5 Sound transmission and insulation	292
Part F6 Condensation management.....	301
Section G Ancillary provisions	
Part G1 Minor structures and components	308
Part G2 Boilers, pressure vessels, heating appliances, fireplaces, chimneys and flues	313
Part G3 Atrium construction	321
Part G4 Construction in alpine areas.....	332
Part G5 Construction in bushfire prone areas	339
Part G6 Occupiable outdoor areas	342
Section H Special use buildings	
Part H1 Class 9b buildings.....	349
Part H2 Public transport buildings.....	354

Part H3 Farm buildings and farm sheds	358
Section I * * * * *	
Part I1 * * * * *	366
Part I2 * * * * *	367
Section J Energy efficiency	
Section J Energy efficiency	372
Part J0 Energy efficiency	379
Part J1 Building fabric.....	382
Part J2 * * * * *	394
Part J3 Building sealing	395
Part J4 * * * * *	397
Part J5 Air-conditioning and ventilation systems.....	398
Part J6 Artificial lighting and power.....	407
Part J7 Heated water supply and swimming pool and spa pool plant.....	412
Part J8 Facilities for energy monitoring	413
Schedule 3 Definitions	
Schedule 3 Definitions	429
Schedule 4 Referenced documents	
Schedule 5 Fire-Resistance of building elements	
Schedule 6 Fire hazard properties	

Copyright and licence notice

© Commonwealth of Australia and the States and Territories of Australia 2019, published by the Australian Building Codes Board



The material in this publication is licensed under a Creative Commons Attribution-NonCommercial—4.0 International licence, with the exception of:

- any third party material
- any trade marks, and
- any images or photographs.

You may not make derivatives of this publication, but may only use a verbatim copy. More information on this CC BY ND license is set out at the [Creative Commons Website](#). Enquiries about this publication can be sent to:

Australian Building Codes Board

GPO Box 2013

CANBERRA ACT 2601

Phone: 1300 134 631

Email: ncc@abcb.gov.au

www.abcb.gov.au.

Attribution

Use of all or part of this publication must include the following attribution:

© Commonwealth of Australia and the States and Territories 2019, published by the Australian Building Codes Board.

Disclaimer

By accessing or using this publication, you agree to the following:

While care has been taken in the preparation of this publication, it may not be complete or up-to-date. You can ensure that you are using a complete and up-to-date version by checking the Australian Building Codes Board website (www.abcb.gov.au).

The Australian Building Codes Board, the Commonwealth of Australia and States and Territories of Australia do not accept any liability, including liability for negligence, for any loss (howsoever caused), damage, injury, expense or cost incurred by any person as a result of accessing, using or relying upon this publication, to the maximum extent permitted by law. No representation or warranty is made or given as to the currency, accuracy, reliability, merchantability, fitness for any purpose or completeness of this publication or any information which may appear on any linked websites, or in other linked information sources, and all such representations and warranties are excluded to the extent permitted by law.

This publication is not legal or professional advice. Persons rely upon this publication entirely at their own risk and must take responsibility for assessing the relevance and accuracy of the information in relation to their particular circumstances.

First Published: February 2019

Print version: 1.0

Release date: May 2019

Introduction

The National Construction Code

The National Construction Code (NCC) is an initiative of the Council of Australian Governments developed to incorporate all on-site construction requirements into a single code. The Building Code of Australia (BCA) is Volume One and Volume Two of the NCC.

The Guide

The Guide is a companion manual to Volume One. It is intended as a reference book for people seeking clarification, illustrations, or examples, of what are sometimes complex BCA provisions.

The two books should be read together. However, the comments in this Guide should not be taken to override the BCA. Unlike the BCA, which is adopted by legislation, this Guide is not called up into legislation. As its title suggests, it is for guidance only. Readers should note that States and Territories may have variations to BCA provisions. This Guide does not cover those variations. For advice on these matters contact your State or Territory building control administration.

This Guide covers only Volume One of the BCA and primarily deals with Class 2 to Class 9 buildings. Volume Two of the BCA contains guidance notes throughout and diagrams and hence is not included in the Guide.

To assist readers, most of the information in this Guide — including section headings, abbreviations and symbols — is formatted as closely as possible to that in the BCA.

Example

Imagine a developer or engineer etc — referred to in the Guide as the building proponent — with a query about the standards needed for the installation of electricity-supply systems. The first step is to record the details of the relevant BCA provision on electricity-supply systems and turn to the corresponding section in the Guide. To illustrate this: in the BCA, comments on electricity-supply systems are partly dealt with under [Section C — Fire Resistance \(C2.13\)](#). In the Guide, readers should turn to [Section C](#) for information. The Guide does not note all related provision numbers but only provides explanation to the provisions that may need elaboration.

Readers will also note that the BCA Deemed-to-Satisfy Provisions list only the minimum requirements that are acceptable as meeting the Performance Requirements.

The Guide generally explains the intent behind the provisions, and why building proponents, need to meet such standards. For example, the Guide clarifies why certain fire-resistance levels (FRLs) are required. It also assists readers by referring them to other related topics or sections in the Guide.

Not all the provisions in the BCA are covered in the Guide. Those not dealt with have been found to be self-explanatory. The Guide contains a number of examples — some written, others in diagram form — which help illustrate provisions. These examples are not absolute, as they cannot take into account every possible permutation of a building proposal. Again, they are intended as a guide only. Other provisions of the BCA must be complied with.

The information in this Guide is provided by the Australian Building Codes Board (ABCB) and is intended as an information service primarily for building professionals.

Because the Guide does not have regulatory force, the ABCB does not accept any responsibility for its contents when applied to specific buildings or any liability which may result from its use.

Governing Provisions

Part A0

* * * * *

Section A Governing Provisions

Part A0 * * * * *

Part A0

* * * * *

The content of [Section A](#), which existed in the Guide to Volume One 2016 has been relocated to explanatory information within [Section A](#) of NCC 2019.

Structure

Part B1

Structural provisions

Section B Structure

Part B1 Structural provisions

Objective

BO1

Functional Statements

BF1.1

BF1.2

Performance Requirements

BP1.1 Structural reliability

BP1.2 Structural resistance

BP1.3 Glass installations at risk of human impact

BP1.4 Buildings in flood areas

BV1 Structural reliability

BV2 Structural robustness

Deemed-to-Satisfy Provisions

B1.0 Deemed-to-Satisfy Provisions

B1.1 Resistance to actions

B1.2 Determination of individual actions

B1.3 * * * * *

B1.4 Determination of structural resistance of materials and forms of construction

B1.5 Structural software

B1.6 Construction of buildings in flood hazard areas

Specification B1.2 Design of buildings in cyclonic areas

1 Scope

2 Roof cladding assemblies

Part B1 Structural provisions

Objective

BO1

The Objective of this Part is to—

- (a) safeguard people from injury caused by structural failure; and
- (b) safeguard people from loss of amenity caused by structural behaviour; and
- (c) protect other property from physical damage caused by structural failure; and
- (d) safeguard people from injury that may be caused by failure of, or impact with, glazing.

The Objective is based on the belief that people should not be subject to risk of injury from a building suffering structural failure—[BO1\(a\)](#). Nor should there be any amenity loss caused by structural behaviour—[BO1\(b\)](#). Additionally, other property should not be at risk of physical damage caused by structural failure—[BO1\(c\)](#) and people should be safeguarded from injury due to failure or impact with glazing —[BO1\(d\)](#).

The term “structural behaviour” as used in [BO1\(b\)](#) can describe deflections, creep, vibration, settlement and the like. Problems with structural behaviour fall short of actual structural failure.

Example

A building could have excessive deflection of a window lintel which causes the glass to shatter. This could interfere with the building’s use without causing it to collapse.

“Loss of Amenity” refers to the loss of a person’s ability to use a building in the manner intended.

Example

Structural deflections could cause a building’s doors to stick, and thus detract from a person’s ability to move about the building.

Functional Statements

BF1.1

A building or structure is to withstand the combination of loads and other actions to which it may be reasonably subjected.

BF1.2

Glazing is to be installed in a building to avoid undue risk of injury to people.

Glazing in a building should not cause injury to people due to its failure or people impacting with it because they did not see it.

Performance Requirements

BP1.1 Structural reliability

[BP1.1](#) consists of two parts:

- performance attributes that a building is required to have; and
- a list of actions to be considered in association with these attributes.

Performance attributes

[BP1.1\(a\)](#) uses the term “with appropriate degrees of reliability” which can be judged with due regard to the possible consequences of failure and the expense, level of effort and procedures necessary to reduce the risk of failure. The measures that can be taken to achieve the appropriate degree of reliability include:

- choice of a structural system, proper design and analysis;
- implementation of a quality policy;

Structure

- design for durability and maintenance; and
- protective measures.

Degrees of reliability of structural elements can be quantified in terms of probabilities of failure with the use of probabilistic models for actions and resistances.

BP1.1(a)(i) is concerned with the serviceability limit states of buildings in terms of local damage, deformation and vibration. Expected actions are actions with high probabilities of occurrence. The acceptable level of serviceability is subjective. The design for serviceability depends to a large extent on professional judgement. The risk of serviceability failure is, historically, of the order of 10^{-1} to 10^{-2} .

BP1.1(a)(ii) is concerned with the ultimate limit states of buildings in terms of strength and stability. Extreme actions are actions with low probability of occurrence. Repeated actions are actions, with high frequencies of occurrence in a given time period, that may cause fatigue or other cumulative failures. The notional probability of failure of structural elements is of the order of 10^{-3} to 10^{-4} for a 50 year reference period. The probability of structural failure is historically of the order of 10^{-6} per year.

BP1.1(a)(iii) is concerned with consequences of unspecified actions and is often referred to as “structural robustness”. It includes, but is not limited to, progressive collapse. Ways to improve structural robustness include providing redundancies, minimum resistances, protective measures, etc.

BP1.1(a)(iv) is concerned with damage to other properties, which may be caused by reasons other than structural if **BP1.1(a)(i)** to **(iii)** are met.

List of actions

BP1.1(b) lists actions to which a building “may reasonably be subjected”. All possible actions cannot be listed. “Engineering judgement” may need to be used to determine all likely actions and in accessing the likely effects of those actions.

Example

Buildings and structures should be able to withstand the effects of wind, rain or snow. However, they would not be expected to withstand the impact of a crashing aeroplane.

BP1.1(b)(xiv) uses the defined term “construction activity actions”. The term only refers to construction activities that may have an effect on the final design such as stacking or propping. The safety of the building during construction is normally controlled by occupational health and safety authorities.

BP1.2 Structural resistance

BP1.2 states the principles for the determination of the structural resistance of materials and forms of construction.

It should be noted that the construction activities referred to in **BP1.2(a)** may be more than those contained in the defined term of “construction activity actions”. For example, welding of structural steel might cause distortion or change the characteristics of the steel, and hence need to be accounted for. For this reason, the defined term has not been used in **BP1.2(a)**.

BP1.3 Glass installations at risk of human impact

Glazing in a building is not always readily visible to all people. It is therefore important to avoid human impact where possible. This may not always be possible. **BP1.3** therefore contains three parts:

- if glazing is broken due to human impact, it must fail in so that small pieces will not cause injury to people (**BP1.3(a)**);
- if human impact could occur, the glazing should be of a strength to resist that impact without breaking (**BP1.3(b)**); and
- to make it more visible, glazing should be marked with a motive or the like (**BP1.3(c)**)

BP1.4 Buildings in flood areas

BP1.4 only applies to buildings in which people are likely to sleep that are located in a flood hazard area, i.e. a Class 2 or 3 building or a Class 4 part of a building, a Class 9a health-care building or a Class 9c building. A flood hazard area is determined by the appropriate authority (usually the relevant local government) as an area to be affected by flood. The determination is usually via a planning instrument. It is important to note that the NCC provision does not override a provision in a planning instrument which may restrict development in a flood hazard area.

BP1.4 states the principles for the design and construction of the specified buildings in a flood event. The principles include preventing—

- the buildings suffering structural damage or collapse due to the hydrostatic effect (pressure of still water), or

Structure

the hydrodynamic effect (force of moving water), or debris impact; and

- the buildings from being lifted off foundations or footings due to the buoyancy effect; and
- foundations and footings being affected by scour or erosion caused by moving water; and
- degradation of structural materials as a result of being immersed in water.

BV1 Structural reliability

BV1 is a means to verify the structural reliability of a structural component or connection in order to meet the requirements of **BP1.1** and **BP1.2**. For further guidance, refer to the ABCB Handbook for Structural Reliability.

BV2 Structural robustness

BV2 is a means to verify the structural robustness of a building or structure in order to meet the requirements of **BP1.1(a)(iii)**. For further guidance, refer to the ABCB Handbook for Structural Robustness.

Part B1 Structural provisions

Deemed-to-Satisfy Provisions

B1.0 Deemed-to-Satisfy Provisions

Intent

To clarify that [BP1.1](#) to [BP1.4](#) will be satisfied if compliance is achieved with [B1.1](#), [B1.2](#), [B1.4](#), [B1.5](#) and [B1.6](#).

Where a solution is proposed to comply with the *Deemed-to-Satisfy Provisions*, the requirements of [BP1.1](#) to [BP1.4](#) may be satisfied by complying with [B1.1](#), [B1.2](#), [B1.4](#), [B1.5](#) and [B1.6](#).

Where a Performance Solution is proposed, the relevant Performance Requirements must be determined in accordance with [A2.2\(3\)](#) and [A2.4\(3\)](#) as applicable. (See commentary on [Part A2](#)).

B1.1 Resistance to actions

Intent

To specify the method of achieving compliance with [BP1.1](#) and [BP1.2](#).

A building or structure must be designed to resist the most critical effect resulting from different combinations of actions. The actions must be combined taking into account the characteristics of the actions and the probability of the simultaneous occurrence of two or more actions. The levels of reliability of the structure when subject to combined actions should be consistent with the levels of reliability implicit in the design events for natural phenomenon (see comments on [Table B1.2\(b\)](#)). When designing for the maximum combined actions, a principle frequently adopted is that the maximum is likely to occur when at least one of the actions is at its maximum value.

B1.2 Determination of individual actions

Intent

To specify the principles for the determination of each action referred to in [BP1.1\(b\)](#) using the relevant editions of AS/NZS 1170 Parts 0, 1, 2 and 3, and AS 1170 Part 4.

Construction activity actions

The term “construction activity action” only refers to construction activities that may need to be accounted for in the final design such as stacking of materials and floor to floor propping.

Windows forming part of a barrier

A window forming part of a barrier is not required to comply with AS/NZS 1170.1. However, a window serving as a barrier must comply with the glazing assembly provisions of AS 2047 or AS 1288. These provisions consider the wind loading on the glass and human impact requirements.

A generic description of building types has been provided to which Importance Levels have been assigned. The “Importance Level” concept is applicable to building structural safety only. More specific examples are provided below. The examples are not exhaustive.

Importance Level 1:

- Farm buildings and farm sheds.
- Isolated minor storage facilities.
- Minor temporary facilities.

Importance Level 2:

- Low rise residential construction.
- Buildings and facilities below the limits set for Importance Level 3.

Importance Level 3:

- Buildings and facilities where more than 300 people can congregate in one area.
- Buildings and facilities with a primary school, a secondary school or day care facilities with a capacity greater

Structure

than 250.

- Buildings and facilities with a capacity greater than 500 for colleges or adult educational facilities.
- Health care facilities with a capacity of 50 or more residents but not having surgery or emergency treatment facilities.
- Jails and detention facilities.
- Any occupancy with an occupant load greater than 5000.
- Power generating facilities, water treatment and waste water treatment facilities, any other public utilities not included in Importance Level 4.
- Buildings and facilities not included in Importance Level 4 containing hazardous materials capable of causing hazardous conditions that do not extend beyond property boundaries.

Importance Level 4:

- Buildings and facilities designated as essential facilities.
- Buildings and facilities with special post disaster functions.
- Medical emergency or surgery facilities.
- Emergency service facilities: fire, rescue, police station and emergency vehicle garages.
- Utilities required as backup for buildings and facilities of Importance Level 4.
- Designated emergency shelters.
- Designated emergency centres and ancillary facilities.
- Buildings and facilities containing hazardous materials capable of causing hazardous conditions that extend beyond property boundaries.

Importance Levels must be assigned on a case by case basis.

Example

A hospital may be of Importance Level 4 if it is the only hospital in an area. The same hospital may be of Importance Level 3 if it is one of many in an area.

A general method for the determination of the Importance Level of any building is to assess the hazard to human life and the impact on the public in the event of building failure as follows:

Building Importance Levels

Hazard To human life	Impact on the public			
	I (Low)	II (Moderate)	III (Substantial)	IV (Extreme)
A (Low)	Level 1	Level 2	Level 2	Level 3
B (Moderate)	Level 2	Level 2	Level 3	Level 3
C (Substantial)	Level 2	Level 3	Level 3	Level 4
D (Extreme)	Level 3	Level 3	Level 4	Level 4

The annual probability of exceedance varies with the type of action.

Example

Building failures due to earthquake or cyclone may be widespread and therefore have more impact on the public than say thunderstorms, that affect relatively smaller areas.

Table B1.2b

The annual probabilities of exceedance in [Table B1.2\(b\)](#) originated from calibrations derived from experience with minor adjustments carried out to achieve consistency.

In cyclonic areas (wind regions C and D as described in AS/NZS 1170.2) it is necessary for metal roof assemblies to be tested in accordance with [Specification B1.2](#). (See [B1.2\(c\)\(iv\)](#)).

B1.3 * * * * *

The content of [B1.3](#), which existed in BCA 2009, has been removed. The provision number [B1.3](#) has been retained without text so as not to change the numbering of the current BCA from that of BCA 2009.

B1.4 Determination of structural resistance of materials and forms of construction

Intent
To specify deemed-to-satisfy materials and forms of construction.

If the materials and construction listed in B1.4 are used, they must comply with the requirements outlined in the relevant sub-clauses.

The structural performance of a building is dependent, not only on the determining of the applicable actions, but also on the methods used to determine resistance to those actions. B1.4 provides a list of material design standards that can be used together with B1.2.

The weight of roof or ceiling insulation, particularly if additional ceiling insulation is used for compliance with the energy efficiency provisions, needs to be considered in the selection of plasterboard, plasterboard fixings and building framing.

For designers seeking structural compliance via Performance Solutions, a major principle in determining structural resistance is that the reliability level of the structure or its components may be at least equal to that already achieved in the Deemed-to-Satisfy Provisions. For a more complete explanation, the reader is referred to ISO 2394—General principles on reliability of structures.

B1.4(h) clarifies which type of glazed assemblies must comply with AS 2047 and which must comply with AS 1288. The reference to heritage windows is intended to apply to windows in heritage buildings. The method of determining a heritage building is normally covered by the appropriate State or Territory authority.

B1.4(i) only applies where a “primary building element” is considered susceptible to attack by subterranean termites. “Primary building element” excludes from the coverage of B1.4(i) building elements which may provide some bracing to a wall, but it is not required as part of their primary function. An example would be plasterboard not required for bracing or external cladding.

B1.4(i)(i) deems that several specified primary building elements are not subject to termite attack (see Figure B1.4).

B1.4(i)(ii) only requires the attachment of a notice regarding the method or system used to protect against termite attack where that method or system is one described in AS 3660.1.

Figure B1.4 Flow chart for identifying if a termite management system is required

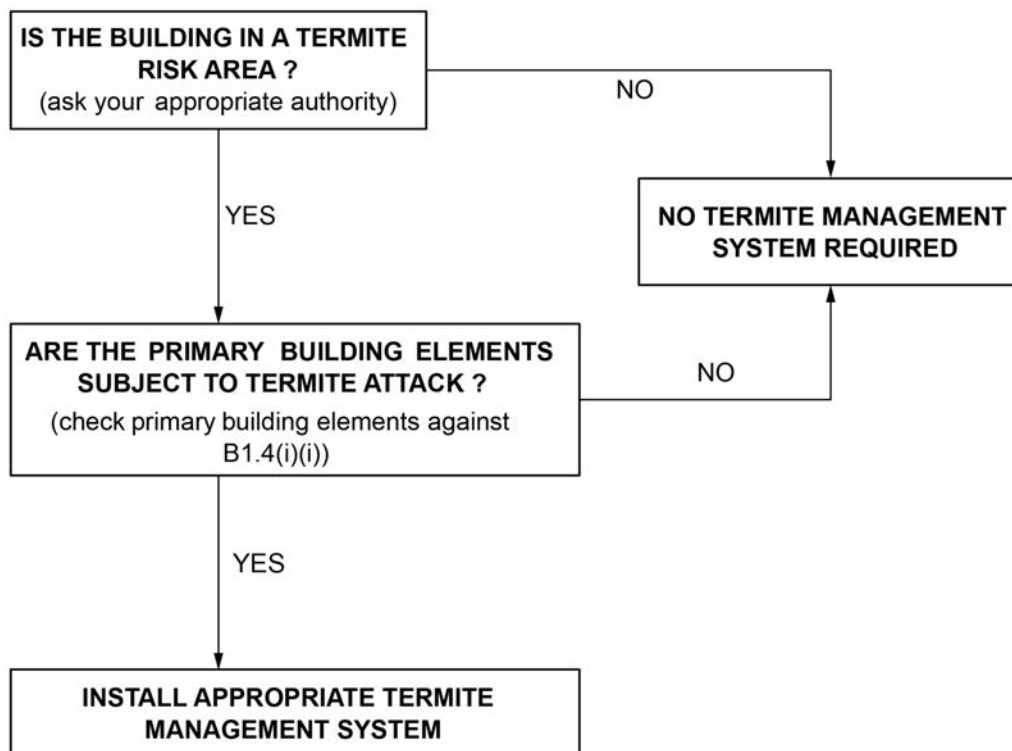

Table B1.4 describes acceptable glazing permitted in the construction of lift shafts. The inherent strengthened qualities of

these glazing types is considered for the purposes of [B1.4\(m\)\(iii\)](#) 'non brittle'.

B1.5 Structural software

[B1.5](#) does not apply where a software package simply eliminates manual calculations and the process of the package requires identical methodology as that undertaken manually, e.g. AS 1684 span tables and bracing calculations.

B1.6 Construction of buildings in flood hazard areas

[B1.6](#) requires the specified buildings in a flood hazard area to comply with the ABCB Standard for Construction of Buildings in Flood Hazard Areas. Under the definition of a 'flood hazard area' the appropriate authority (usually the relevant local government) is responsible for determining the extent of land lower than the flood hazard level. The flood hazard level is used to determine the minimum height of floors of a building above the flood waters. The flood hazard area may be mapped in a local government planning instrument.

The prescriptive provisions of the ABCB Standard only apply to flood hazard areas where the maximum flow velocity is not greater than 1.5 m/s. Where the appropriate authority is unable to determine whether the maximum flow velocity is not greater than 1.5 m/s, the prescriptive provisions only apply to inactive flow or backwater areas, i.e. not directly adjacent to a watercourse or floodway.

Where the maximum flow velocity is greater than 1.5 m/s, it would be necessary to formulate a Performance Solution which complies with the relevant Performance Requirements. This would involve the application of engineering practice to determine appropriate design solutions.

Specification B1.2

Design of buildings in cyclonic areas

1 Scope

Intent

To clarify that [Specification B1.2](#) contains requirements for the design of metal roofing cladding assemblies in cyclonic areas.

This specification must be read in conjunction with the provisions of AS/NZS 1170.2. The ABCB commissioned research to establish a national consistent testing regime for metal roof cladding assemblies in cyclonic areas. The results of this research are contained in [Specification B1.2](#).

2 Roof cladding assemblies

Intent

To define the expected performance of roof cladding assemblies in cyclonic areas when subjected to the specified test regime ([Table 1](#)).

Strength performance of roofing system

Low cycle fatigue cracking of metal roof cladding elements during tropical cyclones is a complex process where small changes in load, geometry or material properties can significantly affect the fatigue performance of the cladding system (includes immediate supports, fixings and cladding). The consequences of failure of an element can quickly lead to more elements progressively failing. These failed elements become wind driven debris and so pose a threat to people and other structures as potential missiles.

Table 1

The fatigue loading sequence defined in [Table 1](#) is to simulate the wind load induced by a cyclonic event. In order to have a repeatable standard test that can be performed by different testing laboratories within a reasonable time frame on different types of test equipment, the loading sequence is a simplification of the dynamic wind loading environment. In the formulation of the fatigue loading sequence assumptions such as cyclone counts, load range, cyclone duration, wind direction change, building orientation and building geometry have been made.

If a system does not successfully resist the fatigue loading sequence in [Table 1](#), it does not comply.

The test section consists of cladding elements, fastenings and immediate supporting members assembled together in a manner identical to those parts of the particular roof which the test section is intended to replicate.

Fire resistance

Section C	Fire resistance
Part C1	Fire resistance and stability
Part C2	Compartmentation and separation
Part C3	Protection of openings

Section C Fire resistance

Section C Fire resistance

Objective

CO1

Functional Statements

CF1

CF2

Performance Requirements

CP1 Structural stability during a fire

CP2 Spread of fire

CP3 Spread of fire and smoke in health and residential care buildings

CP4 Safe conditions for evacuation

CP5 Behaviour of concrete external walls in a fire

CP6 Fire protection of service equipment

CP7 Fire protection of emergency equipment

CP8 Fire protection of openings and penetrations

CP9 Fire brigade access

Verification Methods

CV1 Fire spread between building on adjoining allotments

CV2 Fire spread between buildings on the same allotment

CV3 Fire spread via external walls

CV4 Fire Safety Verification Method

Part C1 Fire resistance and stability

Objective

Functional Statements

Performance Requirements

Deemed-to-Satisfy Provisions

C1.0 Deemed-to-Satisfy Provisions

C1.1 Type of construction required

C1.2 Calculation of rise in storeys

C1.3 Buildings of multiple classification

C1.4 Mixed types of construction

C1.5 Two storey Class 2, 3 or 9c buildings

C1.6 Class 4 parts of buildings

C1.7 Open spectator stands and indoor sports stadiums

C1.8 Lightweight construction

C1.9 Non-combustible building elements

C1.10 Fire hazard properties

C1.11 Performance of external walls in fire

C1.12 * * * * *

C1.13 Fire-protected timber: Concession

C1.14 Ancillary elements

Part C2 Compartmentation and separation

Objective

Functional Statements

Performance Requirements

Deemed-to-Satisfy Provisions

C2.0 Deemed-to-Satisfy Provisions

C2.1 Application of Part

C2.2 General floor area and volume limitations

- C2.3 Large isolated buildings
- C2.4 Requirements for open spaces and vehicular access
- C2.5 Class 9a and 9c buildings
- C2.6 Vertical separation of openings in external walls
- C2.7 Separation by fire walls
- C2.8 Separation of classifications in the same storey
- C2.9 Separation of classifications in different storeys
- C2.10 Separation of lift shafts
- C2.11 Stairways and lifts in one shaft
- C2.12 Separation of equipment
- C2.13 Electricity supply system
- C2.14 Public corridors in Class 2 and 3 buildings

Part C3 Protection of openings

Objective

Functional Statements

Performance Requirements

Deemed-to-Satisfy Provisions

- C3.0 Deemed-to-Satisfy Provisions
- C3.1 Application of Part
- C3.2 Protection of openings in external walls
- C3.3 Separation of external walls and associated openings in different fire compartments
- C3.4 Acceptable methods of protection
- C3.5 Doorways in fire walls
- C3.6 Sliding fire doors
- C3.7 Protection of doorways in horizontal exits
- C3.8 Openings in fire-isolated exits
- C3.9 Service penetrations in fire-isolated exits
- C3.10 Openings in fire-isolated lift shafts
- C3.11 Bounding construction: Class 2 and 3 buildings and Class 4 parts
- C3.12 Openings in floors and ceilings for services
- C3.13 Openings in shafts
- C3.14 * * * * *
- C3.15 Openings for service installations
- C3.16 Construction joints
- C3.17 Columns protected with lightweight construction to achieve an FRL

Specification C1.1 Fire-resisting construction

Deemed-to-Satisfy Provisions

- 1 Scope
- 2 General Requirements
- 3 Type A fire-resisting construction
- 4 Type B fire-resisting construction
- 5 Type C fire-resisting construction

Specification C1.8 Structural tests for lightweight construction

Deemed-to-Satisfy Provisions

Specification C1.10 Fire hazard properties

Deemed-to-Satisfy Provisions

- 1 Scope
- 2 Application
- 3 Floor linings and floor coverings
- 4 Wall and ceiling linings
- 5 Air-handling ductwork

- 6 Lift cars
- 7 Other materials

Specification C1.11 Performance of external walls in fire**Deemed-to-Satisfy Provisions**

- 1 Scope
- 2 Application
- 3 General requirements for external wall panels
- 4 Additional requirements for vertically spanning external wall panels adjacent to columns

Specification C1.13 Cavity barriers for fire-protected timber**Deemed-to-Satisfy Provisions****Specification C1.13A Fire-protected timber**

- 1 Scope
- 2 Requirements
- 3 Determination of the time the timber interface temperature exceeds 300°C for timber at least 75 mm thick

Specification C2.5 Smoke-proof walls in health-care and residential care buildings**Deemed-to-Satisfy Provisions**

- 1 Scope
- 2 Class 9a health-care buildings
- 3 Class 9c buildings
- 4 Doorways in smoke-proof walls

Specification C3.4 Fire doors, smoke doors, fire windows and shutters**Deemed-to-Satisfy Provisions**

- 1 Scope
- 2 Fire Doors
- 3 Smoke Doors
- 4 Fire Shutters
- 5 Fire Windows

Specification C3.15 Penetration of walls, floors and ceilings by services**Deemed-to-Satisfy Provisions**

Section C Fire resistance

Objective

CO1

The Objective of this Section is to—

- (a) safeguard people from illness or injury due to a fire in a building; and
- (b) safeguard occupants from illness or injury while evacuating a building during a fire; and
- (c) facilitate the activities of emergency services personnel; and
- (d) avoid the spread of fire between buildings; and
- (e) protect other property from physical damage caused by structural failure of a building as a result of fire.

Basis of Objective

This Objective is based on the belief that a building should:

- provide people with an environment which, during a fire, will minimise the risk of them suffering illness or injury;
- provide people with an evacuation route which will minimise the risk of them suffering illness or injury while escaping a fire;
- facilitate the role of emergency services personnel, such as the fire brigade, if it becomes necessary for them to undertake such operations as fire-fighting and search and rescue;
- assist in minimising the risk of fire spreading from one building to another; and
- not have a structural failure during a fire that results in damage to another building, allotment or road.

Spread of fire

There is a continuing debate regarding the means by which the BCA should minimise the risk of fire spreading from one building to another. Should the greater degree of fire protection be in the building on fire, or should it be in the building at potential risk of the fire spreading?

Generally, the BCA provisions aim to minimise the spread of fire from the building on fire, but there are some provisions that limit the spread of fire from an adjacent building.

Consequently, [CO1\(d\)](#) states that the spread of fire is to be avoided “between buildings”—that is, in either direction.

Protection of other property

The BCA is principally designed to maximise (within reasonable bounds) the safety, health and amenity of people in and around buildings. Protection of property, either the subject building or what is termed “other property”, is not generally a primary aim of the BCA—although it may sometimes be a consequence of the provisions of the BCA.

However, there are some exceptions to this rule, and the inclusion of “other property” in [CO1\(e\)](#) is one of these. In this context, a building is expected to maintain the level of structural sufficiency necessary to prevent it causing damage to any other property as a result of fire. The reason [CO1\(e\)](#) concerns itself with the protection of other property is primarily because fire from a building should not pose a serious risk to the health, safety and amenity of the public or occupants of another building. See [Schedule 3](#) for definition of “other property”.

Functional Statements

CF1

A building is to be constructed to maintain structural stability during fire to—

- (a) allow occupants time to evacuate safely; and
- (b) allow for fire brigade intervention; and
- (c) avoid damage to other property.

CF2

A building is to be provided with safeguards to prevent fire spread—

Fire resistance

- (a) so that occupants have time to evacuate safely without being overcome by the effects of fire; and
- (b) to allow for fire brigade intervention; and
- (c) to sole-occupancy units providing sleeping accommodation; and

Application:

CF2(c) only applies to a Class 2 or 3 building or Class 4 part of a building.

- (d) to adjoining fire compartments; and
- (e) between buildings.

Structural stability

A building must remain structurally stable during a fire to:

- allow the occupants to safely evacuate;
- allow the fire brigade to undertake search and rescue, if necessary, and fire-fighting operations; and
- avoid damage to another building, allotment or road.

Instability may not contravene the BCA

So long as a building does not endanger life or other property, and the BCA's structural stability criteria have been satisfied, then the building may become structurally unstable after a fire and still comply with the objectives of [Section C](#). It could even collapse, provided none of the building falls in a way that endangers the public or causes damage to another building. For example, if a building falls onto a road, it could endanger the safety of the public and would therefore not achieve the Functional Statement.

Spread of fire

A building must have in-built safeguards to prevent the spread of fire:

- to allow sufficient time for the occupants to safely evacuate;
- to allow the fire brigade to undertake search and rescue, if necessary, and fire-fighting operations;
- in Class 2 or Class 3 buildings or Class 4 parts used as sole-occupancy units that provide sleeping accommodation to allow sufficient time for the occupants to safely evacuate;
- to an adjoining fire compartment; and
- from one building to another building.

Spread of fire may not contravene the BCA

So long as a building fire does not endanger life or other property, and the BCA's spread of fire criteria have been satisfied, then the building may burn and still comply with the aims of [Section C](#).

Performance Requirements**CP1 Structural stability during a fire**

[CP1](#) sets structural stability requirements for building elements during a fire.

[CP1](#) does not make any reference to a fire-resistance level (FRL). FRLs are only included as part of the Deemed-to-Satisfy Provisions.

It may be found by a building proponent using an Alternate Performance Solution that FRLs to building elements are not necessary as other means, such as the use of active systems, satisfy the Performance Requirements.

“To the degree necessary”

[CP1](#) uses the term “to the degree necessary”. This word usage is designed to provide flexibility in the way this provision is implemented. The intended meaning of the term “to the degree necessary” in [CP1](#) and other Performance Requirements, is explained in explanatory information to [A1.0\(3\)\(c\)](#).

It means that the BCA recognises that different building elements require differing degrees of structural stability during a fire. The expression is intended to allow the appropriate authority to determine the degree of compliance necessary in each particular case.

Any decision made in this context can extend to not requiring an item to be installed or a particular level of performance to be achieved, if that is the appropriate action to be taken.

“Appropriate to”

The structural stability must be “appropriate to” the criteria listed in [CP1](#), which relate to such factors as:

Fire resistance

- the likelihood or risk of a fire occurring in the building;
- the load, intensity and potential danger of any fire in the building;
- the difficulty of evacuation and/or rescue;
- a structural element's exposure to fire in another building, or risk of spreading a fire to another building;
- the fire safety systems in the building, which can affect the rate of fire spread (e.g. if a sprinkler system is installed in a building, it could either extinguish the fire or reduce its growth rate);
- the size of a fire and the difficulties in effecting an evacuation;
- the fire-fighting operations of the fire brigade; and
- the consequences of the failure of the element (another way of expressing this is to consider that if the element fails, could it result in the failure of another element).
- the time taken from the start of the emergency to the occupants reaching a safe place.

While assessment of a building proposal must have regard to the differing needs of each building element, the proposal must make sure that the elements have an appropriate structural stability during a fire so that:

- the fire does not endanger the occupants by entering escape routes; and
- the fire does not endanger firefighters while they are undertaking search and rescue operations.

Examples

The following are two examples of what may or may not be “appropriate”. They should not be regarded as absolute, or applicable in all circumstances.

Commercial poultry building

The building concerned is a commercial poultry building which is single storey and occupied by only a few workers, who are likely to know the building well. The building is situated a long distance from any other building and has direct routes to the exit doors.

In such a case, the building elements may not need to be fire protected under [CP1](#) because the occupants would be able to evacuate quickly and if the building collapses, there is little likelihood of it damaging another building.

Note that for the example above, it is assumed that the building in question has not met the criteria to be considered a farm building or farm shed in the Deemed-to-Satisfy Provisions.

High-rise office building

The building concerned is a central city high-rise office building. It is located on the street alignment and close to other similar buildings. In such a case, the structural failure of any of the building elements could lead to danger to building occupants and the general public, failure of building elements intended to protect another building, or the collapse of another element which relies on the first element for structural support.

In this example, building elements may require a high level of protection under [CP1](#).

In both cases, the ability of the fire brigade to control a fire also needs to be considered when considering the implications of [CP1](#).

If the proposal being considered involves a solution that is taking advantage of the Deemed-to-Satisfy Provisions, the Deemed-to-Satisfy Provisions contain detailed requirements for the fire protection of building elements.

If a Performance Solution is being used, it may be appropriate to assess it using the [Section C](#) Deemed-to-Satisfy Provisions for guidance purposes. It is stressed, however, that compliance with the Deemed-to-Satisfy Provisions is not compulsory if alternative means can be found to satisfy the appropriate authority that the Performance Requirements will be achieved. The building proponent should refer to [A2.2](#) for guidance on acceptable assessment methods for determining compliance with the Performance Requirements.

CP2 Spread of fire

[CP2](#) deals with the spread of fire both within and between buildings (including risk of spread of fire via the external walls of the building), and which does not only result from the structural failure of a building element.

[CP2](#) does not make any reference to non-combustibility or a fire-resistance level (FRL). Non-combustibility and FRLs are only included as part of the Deemed-to-Satisfy Provisions. However, proponents of a Performance Solution should note these requirements, as part of developing the Performance Solution, if considered to be applicable. See [CF2](#).

[CP2\(a\)\(i\)](#) aims to avoid a situation where fire either endangers occupants evacuating by way of exits, or impedes the capacity of emergency services personnel to access the building and fight the fire or rescue occupants.

[CP2\(a\)\(ii\)](#) aims to minimise the risk of people in Class 2 and Class 3 buildings and Class 4 parts, for example, if they were sleeping and consequently having difficulty escaping a fire. For this reason, [CP2\(a\)\(ii\)](#) requires that sole-occupancy units

Fire resistance

and corridors used for escaping be provided, to the degree necessary, with protection to avoid the spread of fire.

[CP2\(a\)\(iii\)](#) aims to minimise the risk of fire spreading from one building to another that could endanger the occupants of both buildings and impede the actions of the fire brigade. See [CV1](#) and [CV2](#) for two means of verifying, under certain circumstances, whether or not the requirements of [CP2\(a\)\(iii\)](#) will be achieved. Other assessment methods for determining compliance with the Performance Requirements are in [A2.2](#).

[CP2\(a\)\(iv\)](#) aims to minimise the risk of fire spreading through a building that could endanger the occupants and impede the actions of the fire brigade. [CP2\(a\)\(iv\)](#) requires that a building must have elements that will avoid the spread of fire in a building. This includes avoiding the risk of fire spread via the external walls of the building. [CP2\(a\)\(iv\)](#) covers the risk of fire spread across the building facade due to the increased risk of spread to other compartments of the building, to other adjacent buildings, and the difficulty of firefighting external fires occurring at higher levels.

[CP2\(a\)](#) uses the term “to the degree necessary”. This word usage is designed to provide flexibility in the way this provision is implemented.

It means that the BCA recognises that different building elements require differing degrees of protection to avoid the spread of fire. The expression is intended to allow the appropriate authority to determine the degree of compliance necessary in each particular case after considering each building scenario.

Any decision made in this context can extend to not requiring an item to be installed or a particular level of performance to be achieved, if that is the appropriate action to be taken.

Building elements must be appropriate to avoid spread of fire, taking into consideration the matters listed in [CP2\(b\)](#) including:

- the likelihood or risk of a fire occurring in the building;
- the size, load or intensity of any fire in the building;
- the difficulty of evacuation and/or rescue;
- the building’s exposure to fire in another building, or risk of spreading a fire to another building;
- the fire safety systems in the building, which can affect the rate of fire spread (eg if a sprinkler system is installed in a building, it will either extinguish the fire or reduce its growth rate);
- the size of a fire and the difficulties in effecting an evacuation;
- the fire-fighting operations of the fire brigade and the resources available to it;
- the consequences of the failure of the element (another way of expressing this is to consider that if the element fails, could it result in the failure of another element); and
- the time taken from the start of the emergency to the occupants reaching a safe place.

If a Performance Solution is being used, it may be appropriate to assess it using the [Section C](#) Deemed-to-Satisfy Provisions for guidance purposes. It is stressed, however, that compliance with the Deemed-to-Satisfy Provisions is not compulsory if alternative means can be found to satisfy the appropriate authority that the Performance Requirements will be achieved. The building proponent should refer to [A2.2](#) for guidance on acceptable assessment methods for determining compliance with the Performance Requirements.

Examples

The following are two very simple examples of what may or may not be “appropriate”. They should not be regarded as absolute or applicable in all circumstances.

Commercial poultry building

The building concerned is a commercial poultry building which is single storey and is occupied by only a few workers, who are likely to know the building well. The building is situated some distance from any other building and has direct routes to the exit doors.

In such a case, the building elements may not need to be protected against the spread of fire under [CP2\(a\)](#) because the building is:

- only one fire compartment;
- people are not sleeping in the building; and
- there is little likelihood of the spread of fire to another building because of the large distance to any other building.

Note that for the example above, it is assumed that the building in question has not met the criteria to be considered a farm building or farm shed in the Deemed-to-Satisfy Provisions.

High-rise office building

The building concerned is a central city high-rise office building. It is located on the street alignment and close to other

Fire resistance

similar buildings.

In such a case, the spread of a fire needs to be avoided because:

- the occupants will take some time to evacuate the building, so there is a need to protect the escape routes;
- there is a need for protection from the spread of a fire between each storey, including the risk of fire spread via the external walls of the building where each storey is a separate fire compartment; and
- a fire could easily spread between buildings because they are close together.

In this example, building elements may require a high level of protection against the spread of fire under [CP2\(a\)](#).

In both cases, the ability of the fire brigade to control a fire would also need to be considered when considering the implications of satisfying [CP2\(a\)](#).

If the proposal being considered involves a solution that is taking advantage of the Deemed-to-Satisfy Provisions, the Deemed-to-Satisfy Provisions contain detailed requirements for the fire protection of building elements.

CP3 Spread of fire and smoke in health and residential care buildings

[CP3](#) deals with the spread of fire and smoke within a patient care area of a Class 9a building.

If a fire occurs in a health-care building, most patients would be unable to leave their beds, or may require assistance to evacuate the building. It is therefore important that the areas of the health-care building used by patients in beds be protected from fire in another part of the building.

See definition of “health-care building” in [Schedule 3](#).

[CP3](#) also applies in Class 9c buildings. In this case it applies throughout the whole building, not just in the resident use areas. This is because if a fire occurs in an aged care building, some residents would be unable to leave their beds, or may require assistance to evacuate the building.

CP4 Safe conditions for evacuation

Fire hazard properties of materials

[CP4](#) deals with the fire hazard properties of materials used in the construction of a building. These include such matters as their smoke, toxic gas and heat generation capacities.

[CP4](#) uses the term “to the degree necessary”. This word usage is designed to provide flexibility in the way this provision is implemented.

It means that the BCA recognises that different materials and assemblies must resist the spread of fire to limit the generation of smoke, heat and toxic gases to differing degrees, depending on the circumstances of their use. The expression is intended to allow the appropriate authority to determine the degree of compliance necessary in each particular case after consideration of the building scenario.

Any decision made in this context can extend to not requiring an item to be installed or particular level of performance to be achieved, if that is the appropriate action to be taken.

The materials used in the building must be appropriate to avoid the spread of fire and the generation of smoke, heat and toxic gases after consideration of the matters listed in [CP4](#). The reason for each of these matters is as follows:

- If the occupants can evacuate in a short time, then the smoke, heat and toxic gases generated prior to the completion of the evacuation will be less likely to have an impact on the safety of the occupants than if a longer evacuation time is required.
- The number, mobility and other characteristics of the occupants influence the time taken for the evacuation of the building. If the number of occupants is large, or they are not mobile, such as patients in a hospital or residents of an elderly people’s home, the evacuation time could be long. Such an evacuation time may allow the fire to develop and generate greater amounts of smoke, heat and toxic gases that will endanger the safety of the occupants trying to evacuate.
- The function or use of the building has an impact on the types of materials and linings that are part of the building’s fire load. This directly influences the rate of spread of any fire in the building.
- Any active fire safety system installed in the building, such as a sprinkler system, may limit the spread of fire and allow additional time for the evacuation of the occupants.

The Deemed-to-Satisfy Provision applicable to [CP4](#) is [C1.10](#). [C1.10](#) limits the early fire hazard characteristics of materials susceptible to the effects of flame or heat, particularly during the early stages of a fire.

If a Performance Solution is being used, it may be appropriate to assess it using the [Section C](#) Deemed-to-Satisfy Provisions for guidance purposes. It is stressed, however, that compliance with the Deemed-to-Satisfy Provisions is not

Fire resistance

compulsory if alternative means can be found to satisfy the appropriate authority that the Performance Requirements will be achieved. The building proponent should refer to [A2.2](#) for guidance on acceptable assessment methods for determining compliance with the Performance Requirements.

CP5 Behaviour of concrete external walls in a fire

[CP5](#) is intended to overcome a problem observed when a fire has occurred in a building of “tilt-up construction”, and the panels have collapsed outwards, either during the fire or shortly after with little or no warning, endangering public safety, health, amenity and fire fighting operations.

A wide variety of structural systems and materials are possible to achieve this.

[CP5](#) is only applicable to walls that could collapse as complete panels and, therefore, is not applicable to concrete and clay masonry walls, and the like, because such walls tend to fail in portions, rather than as complete panels.

The height limitation of 2 storeys is based upon the observation that the problem only seems to occur in low-rise buildings. This is due to taller buildings usually having fire rated floors and other building elements to restrain wall panels during a fire.

CP6 Fire protection of service equipment

Certain types of equipment installed in buildings, such as boilers and the like, have a high fire potential. Other types of equipment, such as transformers and batteries, have a high potential for explosion. [CP6](#) aims to minimise the risk of a fire spreading from such equipment to other parts of the building.

[CP6](#) uses the term “to the degree necessary”. This word usage is designed to provide flexibility in the way this provision is implemented.

It means that the BCA recognises that different equipment requires differing levels of protection, depending on the circumstances within which it is used and installed. The expression is intended to allow the appropriate authority to determine the degree of compliance necessary in each particular case.

Any decision made in this context can extend to not requiring an item to be installed or a particular level of performance to be achieved, if that is the appropriate action to be taken.

CP7 Fire protection of emergency equipment

[CP7](#) is intended to protect emergency equipment from the spread of fire within a building. It is important that emergency equipment continues to operate to the required level during an emergency. The length of time it should continue to operate will depend on the particular equipment.

Examples

[CP7](#) requires that the emergency equipment continue to operate for as long as it is needed. Some examples of where protection may be required include:

- the protection of central smoke control plant required to operate in a fire for sufficient time for the occupants to evacuate; and
- the protection of the power supply to emergency lifts for sufficient time for the use of the lifts.

[CP7](#) uses the term “to the degree necessary”. This word usage is designed to provide flexibility in the way this provision is implemented.

It means that the BCA recognises that different emergency equipment requires differing levels of protection, depending on the circumstances within which it is used and installed. The expression is intended to allow the appropriate authority to determine the degree of compliance necessary in each particular case.

Any decision made in this context can extend to not requiring an item to be installed or a particular level of performance to be achieved, if that is the appropriate action to be taken.

CP8 Fire protection of openings and penetrations

[CP8](#) requires openings and penetrations in building elements to resist the spread of fire.

[CP8](#) should be read in conjunction with [CP2](#). [CP8](#) deals with any opening or penetration within a building element, and [CP2](#) deals with the building element itself.

[CP8](#) uses the term “to the degree necessary”. This word usage is designed to provide flexibility in the way this provision is implemented.

It means that the BCA recognises that different building elements require differing levels of protection, depending on the circumstances within which they are used and installed. The expression is intended to allow the appropriate authority to

Fire resistance

determine the degree of compliance necessary in each particular case.

Any decision made in this context can extend to not requiring an item to be installed or a particular level of performance to be achieved, if that is the appropriate action to be taken.

CP9 Fire brigade access

The attending fire brigade must, in many cases, have access to and around a building during a fire, to undertake search and rescue and fire-fighting operations.

Access for the fire brigade should take into consideration such matters as:

- The size and type of the brigade vehicles likely to be required to fight a fire in the building. Consideration should be given to ensuring that the access is wide enough for a large fire truck, able to support the truck's weight, and incorporate a suitable hard stand area if the brigade needs to use pump units to fight the fire.
- The need for the brigade to fight the fire, considering such factors as the size and type of the building, the nature of any fire safety systems in the building, and the contents of the building.

CP9 uses the term “to the degree necessary”. This word usage is designed to provide flexibility in the way this provision is implemented.

It means that the BCA recognises that buildings need different types of fire brigade access. These differences depend on the matters listed in CP9.

Any decision made in this context can extend to not requiring an item to be installed or a particular level of performance to be achieved, if that is the appropriate action to be taken.

Any access for the fire brigade must be appropriate to their needs and the type of vehicles and equipment to be used, having regard to the matters listed in CP9:

- the likelihood or risk of a fire occurring in the building;
- the size, load or intensity of any fire in the building; and
- the fire safety systems in the building, which can affect the rate of fire spread (eg if a sprinkler system is installed in a building, it will either extinguish the fire or reduce its growth rate).

Examples

The following examples indicate circumstances where fire brigade access may not be necessary:

- A small building, with a low level of occupancy and a low fire load may not require access.
- A building located in an area that does not have an operational fire service, or where the fire service is unlikely to reach the building during the course of a fire.

If the proposal being considered involves a solution that is taking advantage of the Deemed-to-Satisfy Provisions, the Deemed-to-Satisfy Provisions contain detailed requirements regarding fire brigade access.

If a Performance Solution is being used, it may be appropriate to assess it using the Section C Deemed-to-Satisfy Provisions for guidance purposes. It is stressed, however, that compliance with the Deemed-to-Satisfy Provisions is not compulsory if alternative means can be found to satisfy the appropriate authority that the Performance Requirements will be achieved. The building proponent should refer to A2.2 for guidance on acceptable assessment methods for determining compliance with the Performance Requirements.

Verification Methods

CV1 Fire spread between building on adjoining allotments

CV1 is a means to verify whether or not a building proposal achieves the requirements of CP2(a)(iii) in minimising the risk of fire spreading between buildings on adjoining allotments. A fire in one building should not cause the spread of fire to another building, because such fire spread potentially endangers public safety, health and amenity.

It is not compulsory for a designer to use CV1. The designer has the choice of using:

- CV1 to verify that a proposal achieves CP2(a)(iii);
- the Deemed-to-Satisfy Provisions of Part C3; or
- another means of verifying that CP2(a)(iii) will be achieved.

If CV1 is used to calculate the level of heat flux, it is important to calculate the level at all the points referred to in Table CV1. The maximum level is not necessarily at the boundary. The size and shape of the openings will influence the level of heat flux.

Fire resistance

Whether a material will ignite from radiant heat depends on the amount of heat and whether an ignition source (such as a spark) is present.

Examples

The following values give some typical examples of the amount of radiant heat necessary to ignite common materials used in buildings and their construction. Note, these figures should not be taken to be absolute, and may be subject to a range of variables.

- **Timber**
 - Ignition in the absence of a spark 35 kW/m²
 - Ignition in the presence of a spark 20 kW/m²
- **Curtain materials**
 - Ignition in the absence of a spark 20 kW/m²
 - Ignition in the presence of a spark 10 kW/m²

There are three mechanisms for transferring heat:

Conduction

Conduction is the transfer of heat from one source to the other when they are in contact.

Convection

Takes place when the flames or fire plume carry the heat to another body. Convection includes the carrying of embers from a burning body that can cause ignition of a second body.

Radiation

Radiation is the transfer of heat from one body to another. In essence this involves one body putting out enough heat to heat up another body without any form of contact, either directly or by way of flames or embers.

Radiation is the main mechanism for heat and fire spread between buildings.

By way of techniques developed in the field of physics, it is possible to calculate the amount of heat given off by a burning building. The answer depends on a number of factors, including:

- the distance from the building;
- the size and shape of the openings in the building;
- the temperature of the fire, which will depend on the:
 - size of the fire, and
 - type of materials burning; and
- the emissivity of any glass in openings in the building. The emissivity is, in comparatively simple terms, a measure of radiant heat reduction through a window opening. The maximum value is 1, but lower figures may be appropriate, depending on such factors as:
 - whether the opening is drencher protected, or
 - whether the opening is a fire window.

CV2 Fire spread between buildings on the same allotment

CV2 is essentially the same as CV1, except that it deals with the spread of fire between two buildings on the same allotment.

It is not compulsory for a designer to use CV2. The designer has the choice of using:

- CV2 to verify that a proposal achieves CP2(a)(iii);
- the Deemed-to-Satisfy Provisions of Part C3; or
- another means of verifying that CP2(a)(iii) will be achieved.

The figures in Table CV2 are essentially the same as those in Table CV1, if an assumption is made that the boundary dividing the buildings to which Table CV1 is applied is half way between each building.

For further information on the use of CV2, refer to the comments on CV1.

CV3 Fire spread via external walls

CV3 is a means to verify whether or not a proposed external wall system achieves the requirements of CP2 in minimising the risk of fire spreading in a building and between buildings via the external walls of the subject building.

Fire resistance

It is not compulsory for a designer to use CV3. The designer has the choice of using–

- CV3 to verify that a proposal achieves CP2;
- The relevant Deemed-to-Satisfy Provisions; or
- another means of verifying that CP2 will be achieved.

If CV3 is used, an external wall system must also be verified against CV1 and CV2, as well as meeting certain other fire safety measures, including ones specific to buildings of Type A and Type B construction.

Other fire safety measures are imposed in recognition that an external wall system tested to AS 5113 may contain combustible elements that still present a risk that needs to be mitigated in order to minimise the risk of fire spread via the external wall of a building.

The external wall system being tested to AS 5113 must reflect what is proposed to be installed, including cavities, cavity barriers, substrates and fixings. However, the external wall system being tested is not intended to include windows and doors.

The supplier or manufacturer of the system may provide a written declaration stating:

- The AS 5113 classification that the supplied system will achieve if installed correctly.
- the minimum design life of the system and any maintenance requirement to achieve the design life.

The installer may provide a written declaration that the installation has been carried out fully in accordance with the supplier's written instructions to achieve the required AS 5113 classification and design life.

CV4 Fire Safety Verification Method

CV4 is a means to verify the fire safety of a building in order to meet the requirements of CP1, CP2, CP3, CP4, CP5, CP6, CP7, CP8 and CP9. For further guidance, refer to the ABCB Handbook for the Fire Safety Verification Method.

Part C1 Fire resistance and stability

Objective

Functional Statements

Performance Requirements

The Objective and Functional Statements for [Section C](#) are at the beginning of [Section C](#) of this Guide. The Performance Requirements for [Section C](#) are at the beginning of [Section C](#).

Deemed-to-Satisfy Provisions

C1.0 Deemed-to-Satisfy Provisions

Intent

To clarify that the requirements of [CP1](#) to [CP9](#) will be satisfied if a building complies with [Parts C1](#), [C2](#) and [C3](#), and [Parts G3](#) and [G6](#), [H1](#) and [H3](#), if applicable.

Most buildings

Where a solution is proposed to comply with the Deemed-to-Satisfy Provisions, [C1.0](#) clarifies that for most buildings compliance with [Parts C1](#), [C2](#) and [C3](#) will achieve compliance with [CP1](#) to [CP9](#). The exceptions to this general rule are as follows:

- If the building contains an atrium, it must comply with [Part G3](#) in addition to [Parts C1](#), [C2](#) and [C3](#).
- If the building contains an occupiable outdoor area, it must comply with [Part G6](#) in addition to [Parts C1](#), [C2](#) and [C3](#).
- If the building comprises of a theatre, stage or public hall it must comply with [Part H1](#) in addition to [Parts C1](#), [C2](#) and [C3](#).
- If the building contains an atrium and one or more theatre, stage or public hall, it must comply with [Parts C1](#), [C2](#), [C3](#), [G3](#) and [H1](#).
- Farm sheds must comply with [Part H3](#) in addition to [Parts C1](#), [C2](#) and [C3](#).

Where a Performance Solution is proposed, the relevant Performance Requirements must be determined in accordance with [A2.2\(3\)](#) and [A2.4\(3\)](#) as applicable. (See commentary on [Part A2](#)).

C1.1 Type of construction required

Intent

To establish the minimum fire-resisting construction required for Class 2–9 buildings.

Minimum type of construction required

[C1.1\(a\)](#) sets out the minimum type of fire-resisting construction required by the *Deemed-to-Satisfy Provisions* for all Class 2–9 buildings.

Type A construction is the most fire-resistant type of construction, Type C construction is the least fire-resistant and Type B construction falls between these two.

[C1.1\(b\)](#) requires building elements to comply with [Specification C1.1](#) for the appropriate type of construction.

Class and height (rise in storeys)

[Table C1.1](#) explains that the required type of construction of a building depends on risk levels as indicated by the Class of building and the building's height as indicated by the rise in storeys. Note that there could be other factors that need to be considered. For example, [C2.2](#) and [Table C2.2](#) examine the maximum permissible size of fire compartments or atriums in buildings for specific types of construction.

Class of building

The Class of building is a measure of the building's likely:

Fire resistance

- use;
- fire load;
- population; and
- mobility of the occupants, such as whether they are sleeping or alert.

Example

Research indicates that if a fire occurs while a person is asleep, the smell of the smoke will not wake them. Response times in residential buildings are longer than in other types of buildings. The BCA thus requires a higher type of construction in residential buildings. See [Table C1.1](#).

Height of building (rise in storeys)

The height (rise in storeys) of the building is relevant as a measure of likely evacuation times and evacuation difficulty.

Types of construction and Performance Solutions

When using a Performance Solution, [Part C1](#) does not apply and there is no need to refer to the types of construction. Nonetheless, if building proponents using Performance Solutions wish to use [Part C1](#) as part of the solution, they can.

C1.2 Calculation of rise in storeys**Intent**

To establish a method for the calculation of the rise in storeys of a building, as a means of helping determine a building's required type of construction.

What is the rise in storeys?—C1.2(a)

Under [C1.2\(a\)](#), the rise in storeys is the sum of the greatest number of storeys at any part of the external walls of a building above ground level and any storeys within the roof space. The reason for the inclusion of any storey within the roof space is that the storey may not have any external walls such as occur with a hip roof.

[C1.2\(a\)\(i\)](#) and [\(ii\)](#) distinguish between the situation where the part of the external walls is within the allotment (in which case it is calculated above finished ground level—[C1.2\(a\)\(i\)](#)), or on the allotment boundary (in which case it is calculated above natural ground level at that point—[C1.2\(a\)\(ii\)](#)).

The rise in storeys is the criteria used to determine the type of construction. This is because the rise in storeys has an impact on:

- the risk of exposure to radiant heat from a fire in another building;
- the risk of emitting radiant heat to another building; and
- the risk to occupants who may need to travel down a stairway to safely evacuate the building.

Definition of storey

"Storey" is defined in [Schedule 3](#). It is advisable to refer to this definition before calculating the rise in storeys of a building.

Calculation of rise in storeys

The calculation of the rise in storeys includes larger mezzanines (see [C1.2\(d\)\(i\)](#)) and situations where two or more mezzanines can create a similar impact to larger mezzanines (see [C1.2\(d\)\(ii\)](#)) because of their potential fire load.

The calculation excludes machinery or similar plant rooms at the top of the building because they do not add significantly to the building's fire load (see [C1.2\(b\)\(i\)](#)) and storeys below ground level in particular circumstances outlined in [Figure C1.2\(1\)](#). This is because basements are not exposed to radiant heat from a fire in another building, nor do they emit any significant heat horizontally.

[C1.2\(b\)\(ii\)](#) describes when storeys partly below ground level are not included in the calculation of the rise in storeys, i.e. when they are treated as basement storeys as described above. Whether a storey is to be excluded from the calculation of the rise in storeys is determined by measuring the extent of the storey above the average ground level at the external wall. If the wall is more than 12 m long, consider only the 12 m length of the wall where the average ground level is lowest. If any wall of a storey is more than 1 m above the average ground level, the storey is included in the calculation of the rise in storeys.

The height of a ceiling in a storey above the average ground level adjacent to the external wall can be determined by calculating the area between the ground level and the ceiling for the length of the wall under consideration (the actual length of the wall or 12 metres, whichever is the lesser) and dividing the area obtained by that length (see [Figure C1.2\(3\)](#)).

Class 7 or 8 with internal storey height over 6 metres—C1.2(c)

Under [C1.2\(c\)](#), a Class 7 or Class 8 building with more than one storey above ground level (see [C1.2\(c\)\(i\)](#)) and which has an internal storey height of 6 metres or more is, from the point of view of potential fire load, considered to be the equivalent

Fire resistance

to 2 storeys (see C1.2(c)(ii)).

Examples of calculating rise in storeys

Figure C1.2(2) illustrates some examples of calculating the rise in storeys of a building.

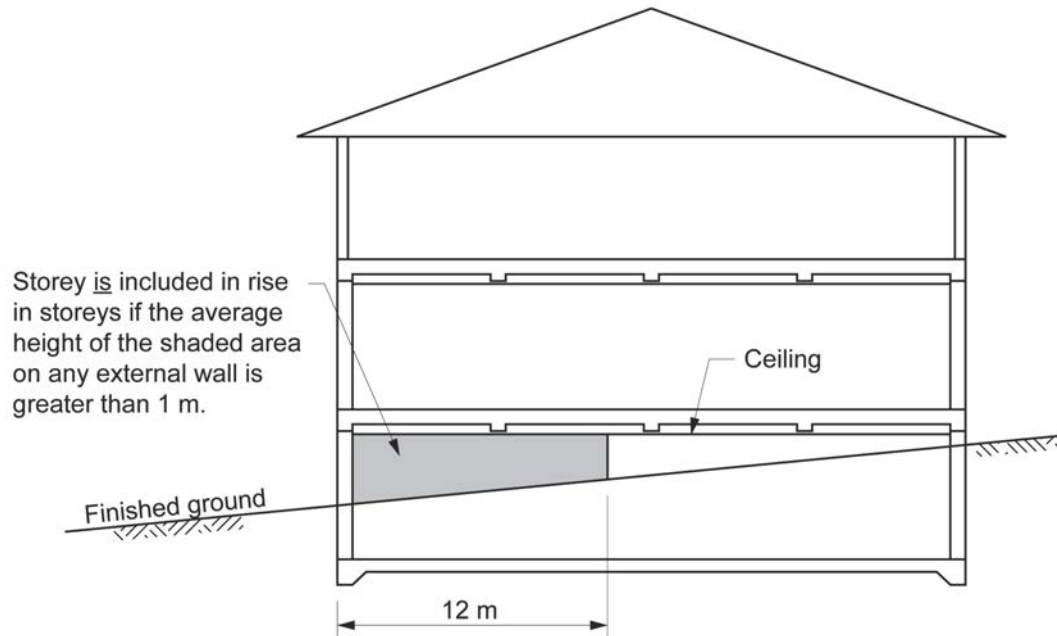
Figure C1.2(1) Section showing storey below ground level included in rise in storeys

Fire resistance

Figure C1.2(2) Examples of calculating the rise in storeys of a building

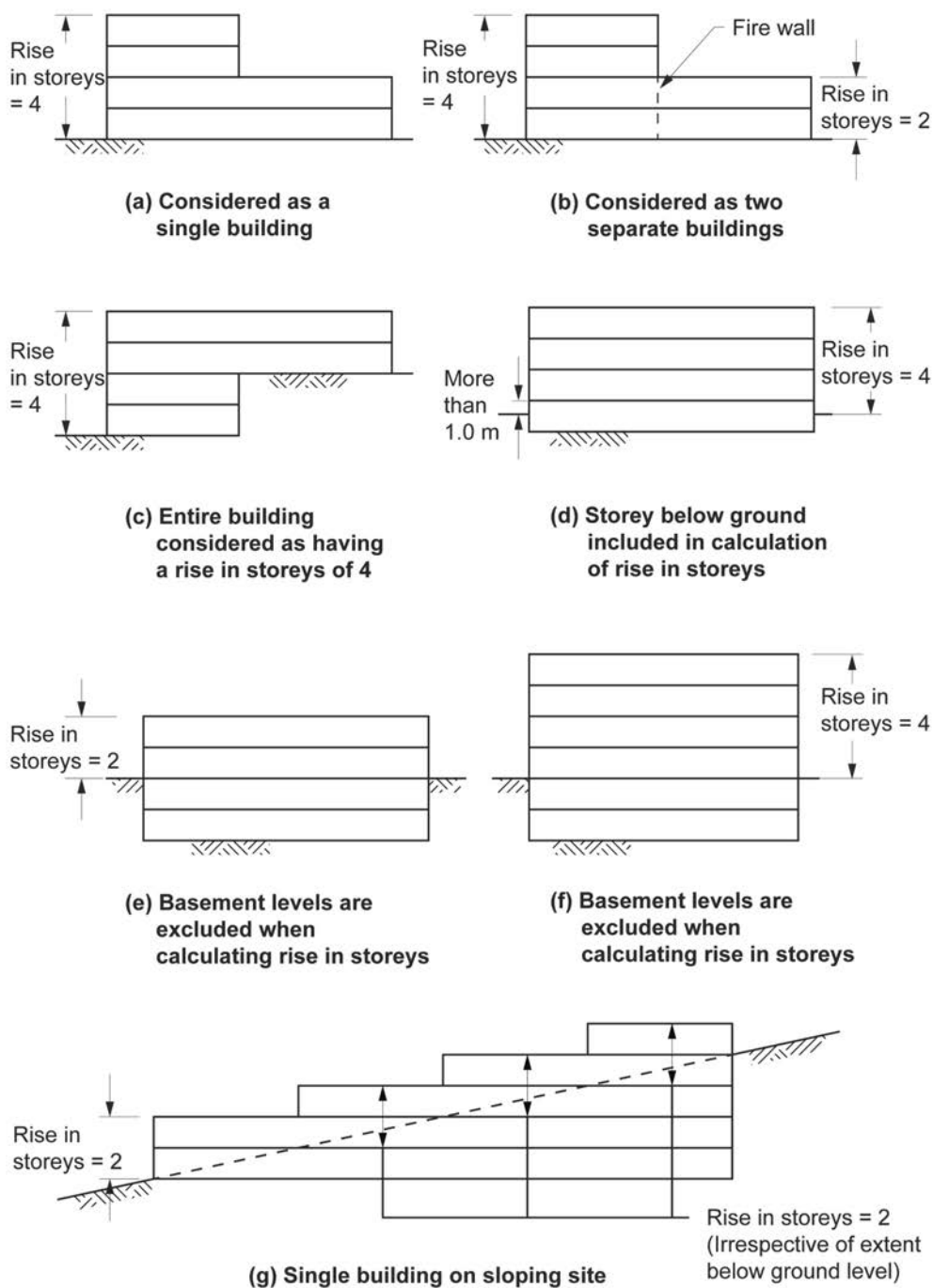
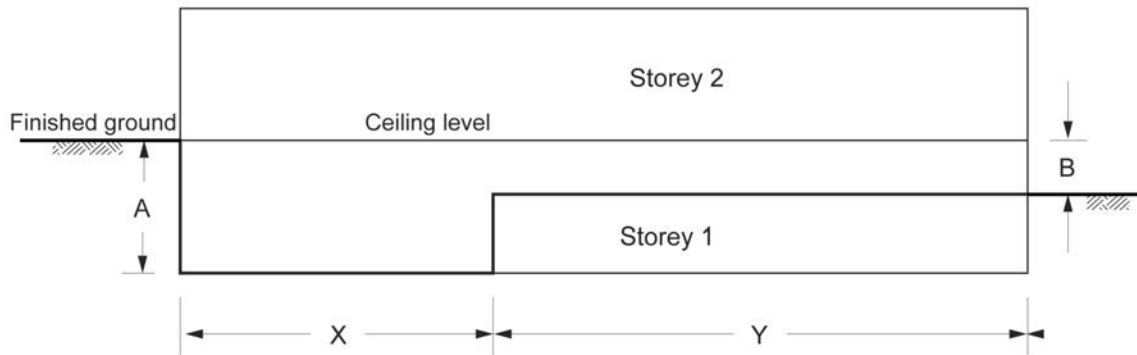
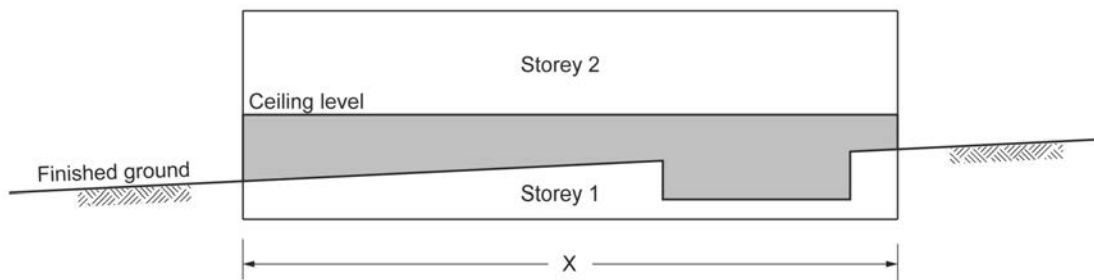

Figure C1.2(3) Determining the height above average level of the ground



$$\text{Height above average ground level} = \frac{(A \times X) + (B \times Y)}{(X + Y)}$$



$$\text{Height above average ground level} = \frac{\text{Shaded area (m}^2\text{)}}{X \text{ (m)}}$$

'Shaded area' is between finished ground and ceiling for the length of the wall under consideration

Note: if the wall is more than 12 m long, consider only the 12 m length of the wall where the average finished ground level is lowest (see [Figure C1.2\(1\)](#)).

C1.3 Buildings of multiple classification

Intent

To establish the type of construction required for a building that contains more than one Class.

Procedure for determining type of construction

In a building comprising multiple classifications, the type of construction applicable to the classification of the top storey applies to all the storeys below it. [Figure C1.3\(1\)](#) illustrates this. This method is used to determine the type of construction only, and not the FRLs required for the different classifications.

Fire resistance

Figure C1.3(1) Method of determining the type of construction required for multi-classified buildings

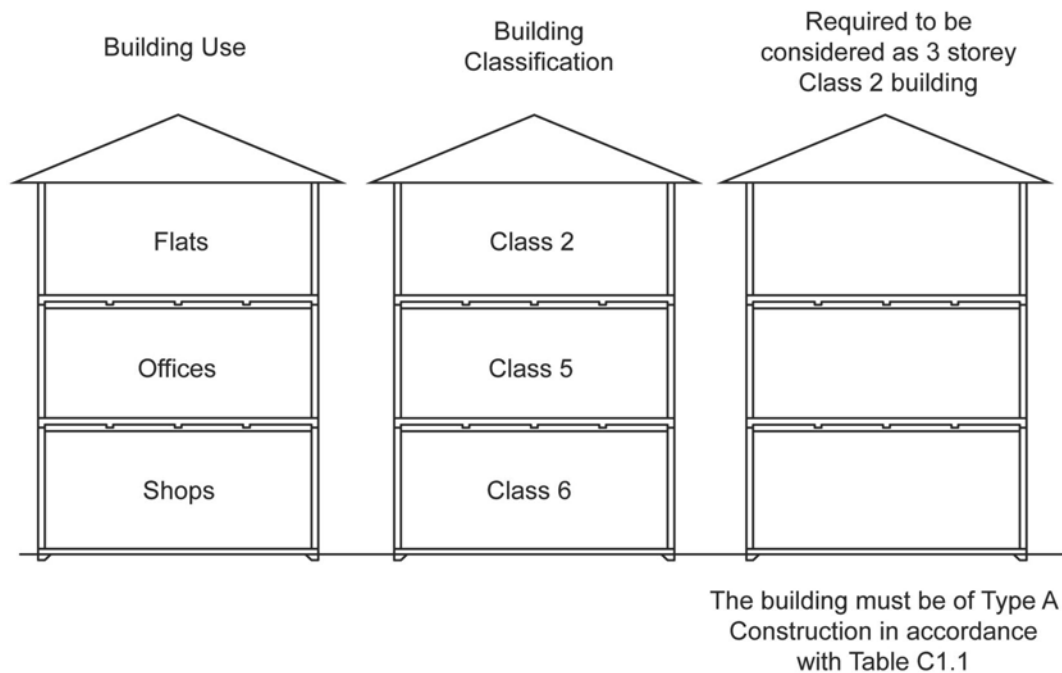
**Where a Class 4 part comprises the top storey**

To determine the type of construction required when a Class 4 part of a building occupies the whole of the top storey, the class of the next highest storey must be applied to the top storey (see [C1.3\(b\)\(i\)](#)). When a Class 4 part of a building occupies only part of the top storey, the required type of construction is determined by the class of the other part of the top storey (see [C1.3\(b\)\(ii\)](#)).

[C1.6](#) must be used to determine the appropriate FRLs for the building elements in the Class 4 part of the building.

Example

In a 3 storey building with the lower 2 storeys of Class 5 and the top storey entirely of Class 4 the Class 5 classification would be applied to the top storey as shown in [Figure C1.3\(2\)](#). Thus the required type of construction by the use of [Table C1.1](#) would be at least Type B construction.

Fire resistance

Figure C1.3(2) Multi-classified building for above example

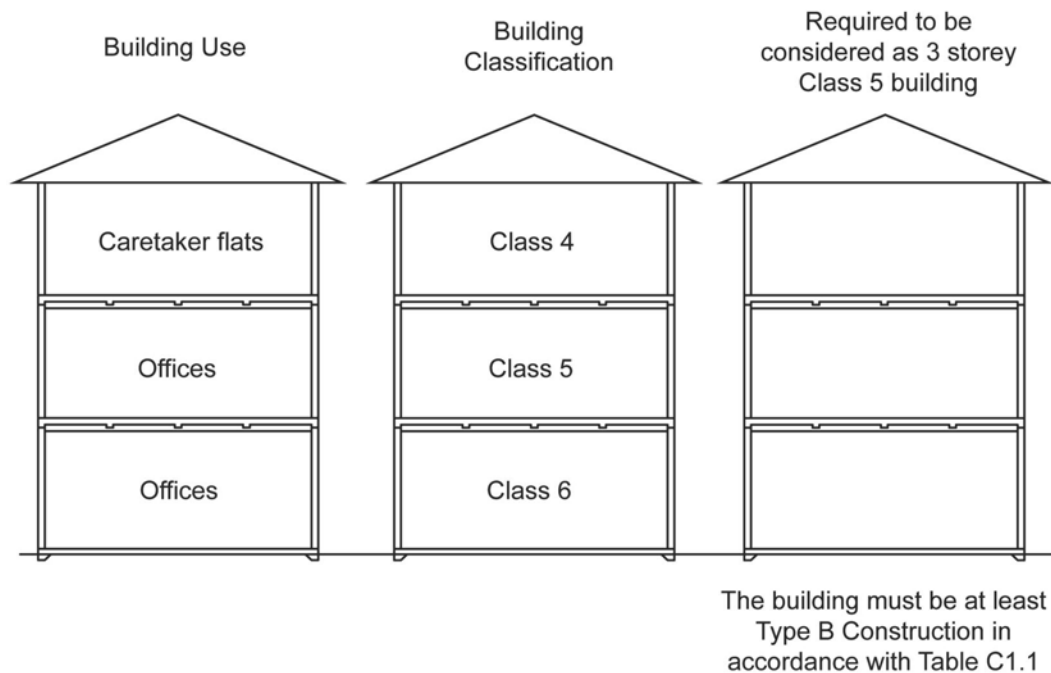

C1.4 Mixed types of construction

Intent

To specify the circumstances in which a building may be of more than one type of construction.

Separation by a fire wall

The only circumstance in which the Deemed-to-Satisfy Provisions allow a building to be of different types of construction is when the types are separated from one another by a fire wall as described in [C2.7\(b\)](#).

Different types must not be above one another

In no case do the Deemed-to-Satisfy Provisions allow different types of construction to be above one another.

C1.5 Two storey Class 2, 3 or 9c buildings

Intent

To grant concessions for:

- low-rise Class 2 and Class 3 buildings provided with a good means of egress; and
- sprinkler protected Class 9c buildings.

Low-rise Class 2 and Class 3 buildings

The concession for Class 2 and Class 3 buildings is made on the basis that the level of risk to occupants does not warrant the full application of the type of construction requirements.

The circumstances outlined in [C1.5\(a\)](#) and [\(b\)](#) are alternative options. They do not have to both exist to bring the [C1.5](#) concession into operation.

The concession also applies to a building containing a mixture of Class 2 and Class 3.

[Figure C1.5](#) illustrates an example of the use of the concession allowed by [C1.5](#).

Low-rise Class 9c buildings

The concession for Class 9c buildings recognises the benefits of sprinkler systems and differences between Types A, B and C construction. It must be remembered that the Class 9c building must comply with all the other BCA provisions, including the floor area limitations contained in [Table C2.2](#).

C1.6 Class 4 parts of buildings

Intent

To specify that Class 4 parts of buildings are subject to the same requirements for fire-resistance levels (FRLs) and separation as would apply to Class 2 parts in similar circumstances.

Class 4 FRLs the same as Class 2

The reason for requiring the same FRL for a Class 4 as a Class 2 building is because the two different classifications have similar fire loads. It should be noted that the Type of construction required for a Class 4 part is determined in accordance with [C1.3](#).

In a building fire, the people most at risk include those who are sleeping. It is therefore important that the residential part of the building be fire separated from the other parts. The fire-resistance levels (FRLs) required for structural elements in a Class 4 part of a building are identified in [Tables 3, 4 or 5 of Specification C1.1](#).

Figure C1.5 Example of the concession allowed by C1.5

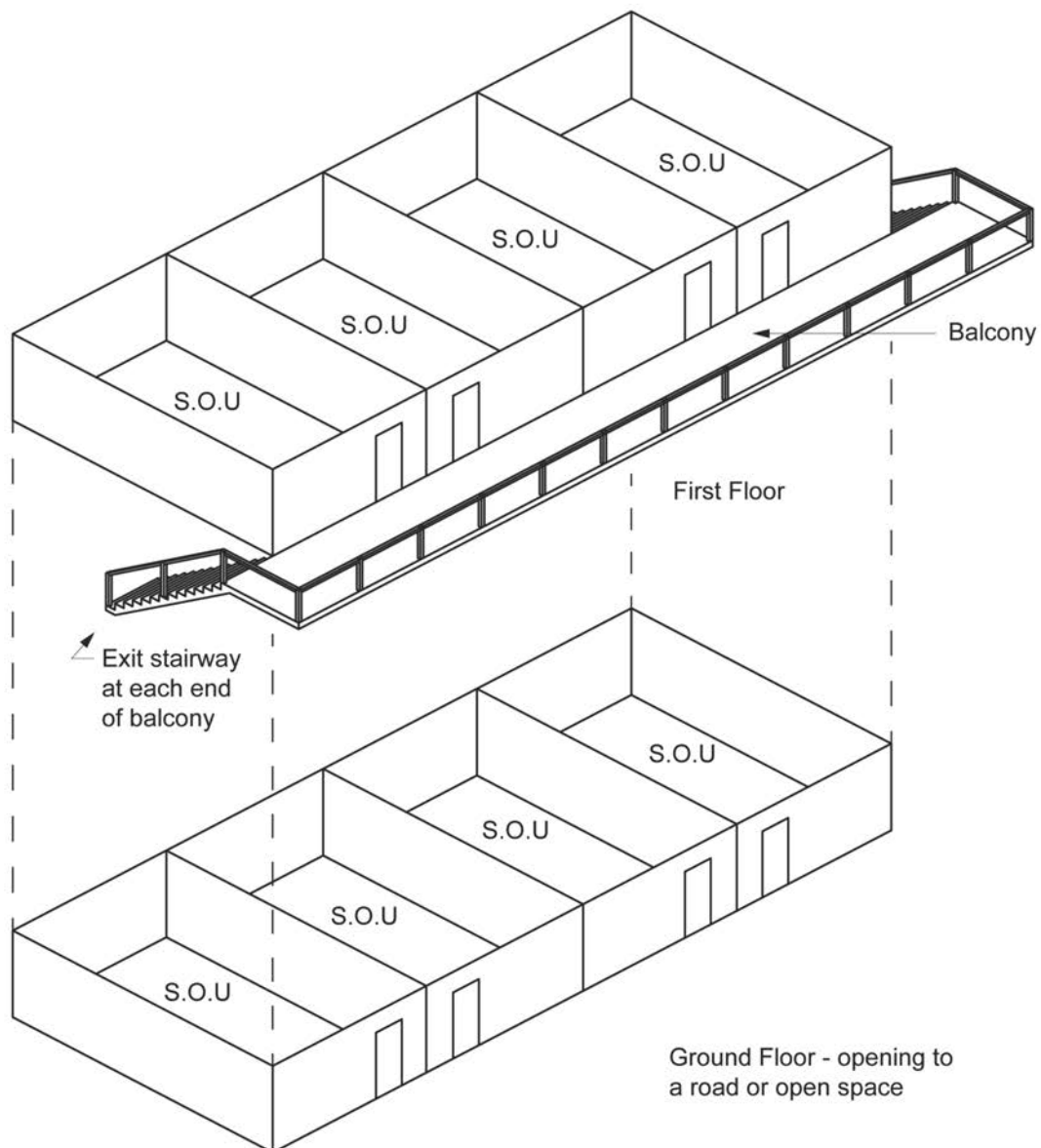

C1.7 Open spectator stands and indoor sports stadiums

Intent

To grant a concession for open spectator stands and indoor sports stadiums.

Indoor sports stadiums

Under specified circumstances (see [C1.7\(a\)](#)), an indoor sports stadium may be of Type C construction.

The reason for this concession is that although an indoor sports stadium may have a high population, particularly during an event, it generally has a lower fire load than other Class 9b buildings. For example, in most stadiums:

- large areas are usually inaccessible to the public (being taken up as part of the sporting events); and
- the finishes are generally spartan.

Open spectator stand

Under specified circumstances (see [C1.7\(a\)](#)), an open spectator stand may be of Type C construction. The reason for this concession is that an open spectator stand generally has a low fire load, even though it may have a high population, particularly during an event; and is open at the front thereby not allowing the build up of smoke and heat.

Tier of seating—[C1.7\(b\)](#) and [Figure C1.7](#)

[C1.7\(b\)](#) refers to a “tier of seating”. This describes the levels of seating in an open spectator stand. [Figure C1.7](#) illustrates a single tiered open spectator stand, and a two tiered open spectator stand.

C1.8 Lightweight construction

Intent

To specify the requirements for the use of lightweight construction in:

- circumstances which require walls with a fire-resistance level (FRL);
- certain high use buildings; and
- fire-resisting covering of steel columns or the like.

Definition of “lightweight construction”

Refer to [Schedule 3](#) for the definition of “lightweight construction”.

Fire resistance

Figure C1.7 Single tiered and two tiered seating in an open spectator stand

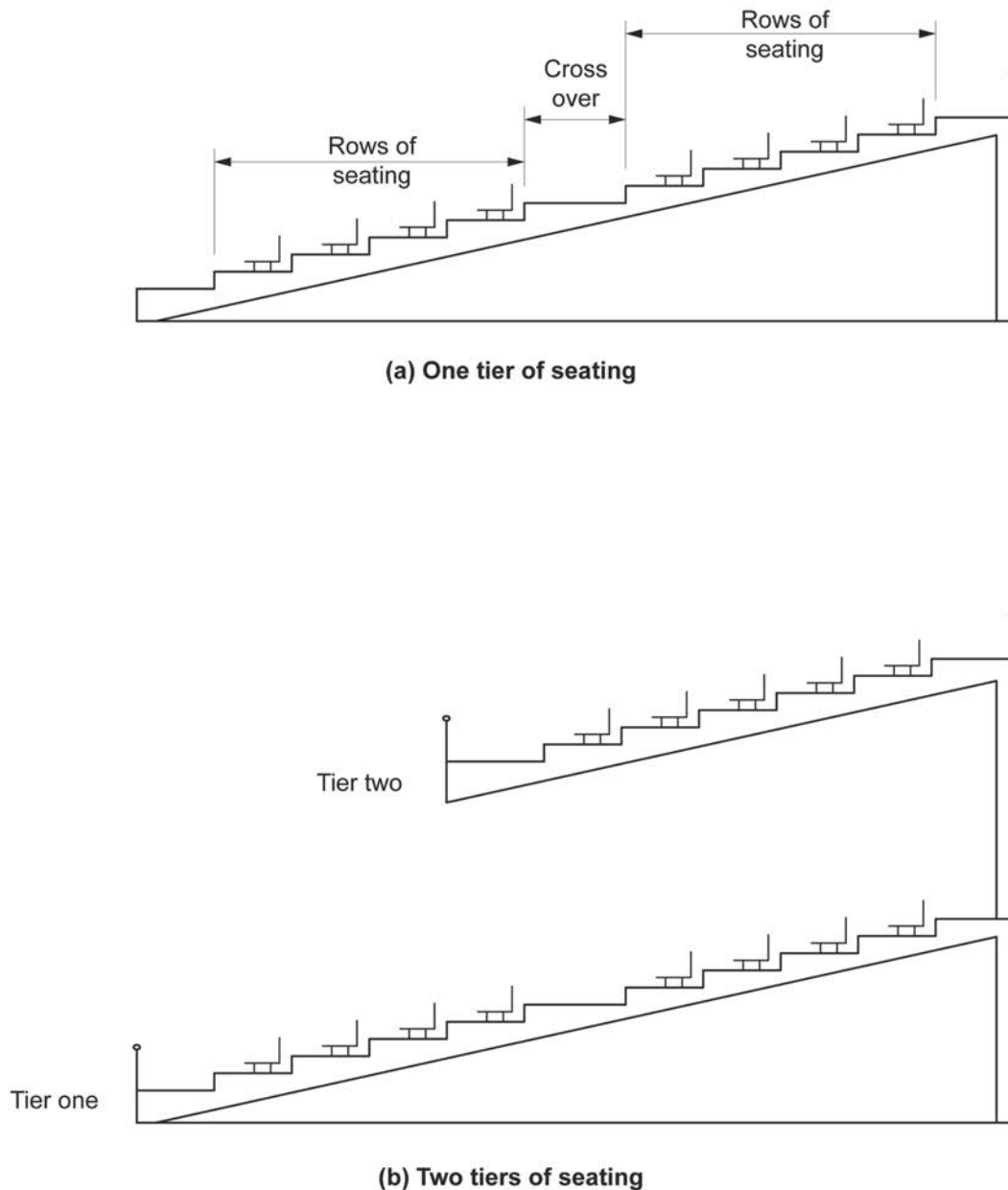
**Lightweight construction needs protection**

Lightweight construction needs protection to preserve its integrity from mechanical damage in a fire or other situation where it may be particularly subject to risk of damage. This is because it is generally more susceptible to damage than other forms of wall construction, such as concrete (which does not contain soft materials) and masonry thicker than 70 mm.

Specification C1.8

To make sure lightweight construction performs correctly, C1.8 states that it must comply with Specification C1.8. This Specification sets down tests which such construction must satisfy.

Walls required to have an FRL—C1.8(a)(i)

Lightweight construction used in any wall system required to have a FRL must comply with Specification C1.8 (see C1.8(a)(i)).

Walls not required to have an FRL—C1.8(a)(ii)

Lightweight construction must also comply with Specification C1.8 if it is used in a wall system which is not required to have a FRL, but is specifically listed in C1.8(a)(ii) or in a building specifically listed in C1.8(a)(ii).

There is no requirement to comply with Specification C1.8 where lightweight construction is used for walls which:

Fire resistance

- are not listed in [C1.8\(a\)\(ii\)](#);
- are in buildings which are not listed in [C1.8\(a\)\(ii\)](#); and
- do not require fire-resistance levels.

Fire-resisting covering of steel columns—C1.8(b)

[C1.8\(b\)](#) sets out the circumstances under which lightweight construction is permitted to be used as a fire-resisting covering for steel columns and the like.

C1.9 Non-combustible building elements

Intent
To specify the non-combustibility for building elements and to permit the use of certain materials that are known to provide acceptable levels of fire safety where an element is required to be non-combustible.

The following table lists building elements required to be non-combustible, concrete, or masonry in a building of Type A construction.

Building elements required to be non-combustible, concrete, masonry or fire-protected timber in a building of Type A construction

Building element	Type A construction
External wall	Non-combustible
Common wall	Non-combustible
Floor and floor framing of lift pit	Non-combustible
All loadbearing internal walls (including those of shafts)	Concrete, masonry or fire-protected timber
Loadbearing fire walls	Concrete, masonry or fire-protected timber
Non-loadbearing walls required to be fire-resistant	Non-combustible
Non-loadbearing lift, ventilation, pipe, garbage and like shafts which do not discharge hot products of combustion	Non-combustible

The following table lists building elements required to be non-combustible, concrete, masonry or fire-protected timber in a building of Type B construction.

Building elements required to be non-combustible, concrete, masonry or fire-protected timber in a building of Type B construction

Building element	Type B construction
External wall	Non-combustible
Common wall	Non-combustible
Floor and floor framing of lift pit	Non-combustible
All loadbearing internal walls (including those of shafts)	Concrete, masonry or fire-protected timber
Loadbearing fire walls	Concrete, masonry or fire-protected timber
Non-loadbearing walls required to be fire-resistant	Non-combustible
Non-loadbearing lift, ventilation, pipe, garbage and like shafts which do not discharge hot products of combustion	Non-combustible (subject to conditions outlined in C1.9(b))

It should be noted that [Parts C1, C2 and C3](#) and the associated Specifications contain some further non-combustibility requirements for certain building elements.

Note also that [C1.9](#) and other Deemed-to-Satisfy Provisions contain a number of concessions from non-combustibility. For example, [C1.13](#) allows fire-protected timber to be used where an element is required to be non-combustible.

[C1.9\(d\)](#) allows a concession from the requirement for non-combustibility for minor ancillary items forming part of an external wall. These minor ancillary items include gaskets, caulking, sealants and damp-proof courses. They may be used wherever a material is required to be non-combustible. In some instances the material may contain combustible components.

[C1.9\(e\)](#) lists materials deemed to be non-combustible. These materials may be used wherever a material is required to be non-combustible. In some instances the material may contain combustible components. The materials listed are not intended to apply to fire place hearths (see [G2.3](#)).

C1.10 Fire hazard properties

Intent

To stipulate the minimum fire hazard properties of materials inside a building susceptible to the effects of flame or heat.

Occupants must be able to evacuate

It is important that the spread of fire and the development of smoke be limited during a fire until building occupants have had time to evacuate. See [CP4](#).

[C1.10\(a\)](#) lists the internal linings, materials and assemblies that must comply with [Specification C1.10](#).

Materials deemed to comply

[C1.10\(c\)\(i\)](#) and [\(ii\)](#) list materials that are not required to comply with [C1.10\(a\)](#). These materials are deemed to comply and accordingly no tests are required to prove that these materials meet the requirements of [C1.10\(a\)](#).

Fire retardant coatings not acceptable

Some paints have been designed to reduce flame spread on combustible materials. These paints, usually referred to as “fire retardant paint”, cannot be used to achieve any of the required fire hazard properties.

This material is unable to be used because of its susceptibility to damage.

[C1.10\(b\)](#) does not prohibit the use of suitable impregnated materials that achieve the relevant fire hazard properties.

Exempted building parts and materials

[C1.10\(c\)\(iii\)](#) to [\(xv\)](#) is a practical recognition that a number of building components and materials are unlikely to significantly contribute to the spread of fire and smoke, because of their size, construction, location and so on. The listed components and materials need not comply with [C1.10\(a\)](#).

[C1.10\(c\)\(ix\)](#) grants an exemption to permit the use of glass reinforced polyester (GRP) in single storey buildings required to be of Type C construction.

The material is limited to GRP because it does not droop or drip when alight. Furthermore, [C1.10\(c\)\(ix\)](#) limits the disposition and quantity of the GRP for use in the roof. This restriction is to reduce the likelihood of the rapid horizontal spread of fire over large sections of roofing.

Accordingly, for the exemption to be used there must be:

- separation between individual roof lights made of this material;
- a restricted area for each roof light; and
- only a portion of the total roof sheeting made up of GRP.

GRP does not have the Spread-of-Flame Index and Smoke-Developed Index required by the Specification. However, the [C1.10\(c\)\(ix\)](#) concession is provided because if GRP is installed in the prescribed manner, its use in single storey buildings of Type C construction will not materially increase the risk of spread of fire and smoke.

[C1.10\(c\)\(xii\)](#) refers to elements within buildings such as joinery units, cupboards, shelving and the like which are typically attached to the building structure, however do not form part of the building structure. These elements are exempt as they do not form part of the structure and typically are not included within building works approval. Notwithstanding that these elements are often fixed to the building structure for stability, they are generally of low hazard and may be likened to any building furniture which is not subject to the fire hazard properties provisions.

Likewise, [C1.10\(c\)\(xiii\)](#) exempts certain types of non-building fixtures such as whiteboards, curtains and blinds, etc. Again, these elements are exempt as they do not form part of the structure and typically are not included within building works approval. It should be noted that not all such fixtures are exempt and reference needs to be made to [C1.10\(a\)](#) to determine which elements must comply.

C1.11 Performance of external walls in fire

Intent

To minimise the risk of any concrete external wall collapsing outwards as a complete panel during a fire.

See the comments on [CP5](#) for the reasons for [C1.11](#); and why [C1.11](#) only applies to a building having a rise in storeys of 1 or 2.

[Specification C1.11](#) contains:

- detailed solutions to avoid the potential collapse, as whole panels, of concrete external walls in a building with

Fire resistance

- a rise in storeys of 2 or less; and
- minimum design loads which panel connections must resist during a fire, to minimise the risk of panels collapsing outwards.

C1.12 * * * * *

The content of [C1.12](#), which existed in NCC 2016, has been relocated and combined with other provisions at [C1.9](#). The provision number [C1.12](#) has been retained without text so as not to change the numbering of the current NCC from that of NCC 2016.

C1.13 Fire-protected timber: Concession**Intent**

To permit fire-protected timber to be used where an element is required to be non-combustible.

[C1.13](#) provides requirements for when fire-protected timber can be used where an element is required to be non-combustible.

Limitations of the building

[C1.13\(a\)](#) to [\(c\)](#) has specific limitations for a building to use the concession for fire-protected timber.

[C1.13\(a\)](#) requires a building to be a separate building, or a part of building to be separated from the remainder of the building. This includes separation via a fire wall where the part of the building only occupies part of a storey. Where the part of the building is below or above another classification, floor separation must be provided. A fire wall or floor required to have an FRL under [C1.13\(a\)\(ii\)](#) cannot consist of fire-protected timber.

To use the concession, a height limitation in [C1.13\(b\)](#) requires the building to have an effective height of not more than 25 m. [C1.13\(c\)](#) also requires the building to be sprinkler protected in compliance with [Specification E1.5](#) (other than by a FPAA 101D or FPAA101H system). This is for the purpose of the [C1.13](#) concession and is in addition to the sprinkler requirements of [E1.5](#).

Construction requirements

[C1.13\(d\)](#) and [\(e\)](#) have specific construction requirements as part of the concession. Under [\(d\)](#), where insulation is installed in a fire-protected timber system, the insulation must be non-combustible.

[C1.13\(e\)](#) requires cavity barriers for fire-protected timber to be provided in accordance with [Specification C1.13](#). A cavity barrier referred to in [C1.13\(e\)](#) is a barrier/enclosure within, around or adjacent to the fire-protected timber to limit the spread of fire, smoke and hot gases in the event of a fire.

C1.14 Ancillary elements**Intent**

To permit certain building components that may contain a limited amount of combustible material to be attached to an external wall required to be non-combustible.

[C1.14](#) prescribes certain allowable ancillary elements that may form part of or be attached to an external wall required to be non-combustible, subject to certain limitations or conditions. These conditions include the ancillary element being constructed of materials meeting certain fire properties, and limitations on its potential extent of coverage of the wall.

Part C2 Compartmentation and separation

Objective

Functional Statements

Performance Requirements

The Objective and Functional Statements for [Section C](#) are at the beginning of [Section C](#) of this Guide. The Performance Requirements for [Section C](#) are at the beginning of [Section C](#).

Deemed-to-Satisfy Provisions

C2.0 Deemed-to-Satisfy Provisions

Intent

To clarify that the requirements of [CP1](#) to [CP9](#) will be satisfied if a building complies with [Parts C1](#), [C2](#) and [C3](#), and [Parts G3](#), [H1](#) and [H3](#), if applicable.

Where a solution is proposed to comply with the Deemed-to-Satisfy Provisions, [C2.0](#) clarifies that for most buildings compliance with [Parts C1](#), [C2](#) and [C3](#) will achieve compliance with [CP1](#) to [CP9](#). The exceptions to this general rule are set out below:

- If the building contains an atrium, it must comply with [Part G3](#) in addition to [Parts C1](#), [C2](#) and [C3](#).
- A building which comprises a theatre, stage or public hall must comply with [Part H1](#) in addition to [Parts C1](#), [C2](#) and [C3](#).
- If the building contains an atrium and one or more of a theatre, stage or public hall, it must comply with [Parts C1](#), [C2](#), [C3](#), [G3](#) and [H1](#).
- Farm sheds must comply with [Part H3](#) in addition to [Parts C1](#), [C2](#) and [C3](#).

Where a Performance Solution is proposed, the relevant Performance Requirements must be determined in accordance with [A2.2\(3\)](#) and [A2.4\(3\)](#) as applicable. (See commentary on [Part A2](#)).

C2.1 Application of Part

Intent

To clarify that the floor area limitations of [Part C2](#) do not apply to certain buildings.

The floor area limitations of [Part C2](#) do not apply to a carpark containing a sprinkler system complying with [Specification E1.5](#) (other than a FPAA101D or FPAA101H system), an open-deck carpark or an open spectator stand.

The separation requirements of potentially explosive batteries from the rest of the building contained in [C2.12\(a\)\(v\)](#) do not apply to Class 8 electricity network substations. These batteries have inherent and specific protection, segregation and risk mitigation measures. They are housed within the substation, with other electrical equipment which the batteries are dedicated to support. The other ancillary building services in the substation are always kept separate from the batteries and further internal separation is not considered necessary.

C2.2 General floor area and volume limitations

Intent

To limit the size of any fire in a building by limiting the size of the floor area and volume of a fire compartment.

Allowable size of the fire compartment

Under [C2.2\(a\)](#) and [Table C2.2](#), the allowable size of the fire compartment depends on two things. The first is the type of construction, which is a measure of a building's ability to resist a fire. The second is the classification of the building, which is an indicator of a building's potential fire load.

Fire resistance

Example

In the case of a Class 7 building which has an area of 3 000 m², C2.2 enables three potential solutions. The building can be:

- Type C construction if it is divided into fire compartments with areas less than those specified in Table C2.2, or if use can be made of the concessions and requirements of C2.3(a); or
- Type A or Type B construction, because the area of the building falls within that permitted under Table C2.2.

Machinery and plant rooms

Under C2.2(b), machinery and plant rooms at the top of a building are not included in the calculation of a building's floor area or volume of a fire compartment. The BCA assumes that such rooms represent a low risk to people in case of fire because of the generally:

- low fire load;
- low number of people who use them; and
- as the occupants of most buildings evacuate downwards, a fire in a plant room at the top of a building will generally not interfere with the ability to evacuate.

Atriums

Under C2.2(c), in an atrium, the area of the atrium well above the floor of the atrium is excluded from the volume calculation because there is no space in which to store materials, thus it is assumed that it does not contribute to the fire load. See Part G3.

Class 9c buildings

Table C2.2 allows sprinkler protected Class 9c buildings to have a maximum fire compartment size of—

- if the building is of Type A construction—8 000 m²; or
- if the building is of Type B construction—5 000 m²; or
- if the building is of Type C construction—3 000 m².

Buildings of mixed classifications

C2.2 makes no reference to the use of Table C2.2 for a building containing mixed classifications. The table specifies both the maximum allowable floor area and volume of certain fire compartments and atria.

To calculate the maximum permissible floor area component of the size limitations in Table C2.2, firstly take the percentage of each classification as a proportion of the actual floor area of the building.

Then, use this percentage to calculate the proportion of the maximum floor area permitted for that classification in Table C2.2 and then add each of those calculations together to come to a maximum permitted floor area for the combined classifications. This is illustrated in simpler terms in the example below.

Example

Figure C2.2 shows a building of Type C construction containing a factory (Class 8) with an office (Class 5) at the front. The total area of the building is 2 100 m².

The area of the Class 8 portion of the building is 80% (1 680 m²) of the floor area of the whole building (that is, the combined Class 8 and Class 5 portions).

The area of the Class 5 portion of the building is 20% (420 m²) of the floor area of the whole building (that is, the combined Class 8 and Class 5 portions).

To determine if such a building complies with Table C2.2, the following calculations are necessary:

- Maximum area of Class 8 allowed by Table C2.2 = **2 000 m²**
- The percentage of Class 8 is 80% = 80% of 2 000 m² = **1 600 m²**
- Maximum area of Class 5 allowed by Table C2.2 = **3 000 m²**
- The percentage of Class 5 is 20% = 20% of 3 000 m² = **600 m²**
- Maximum allowable floor area = 1 600 + 600 = **2 200 m²**

The maximum allowable floor area of the building is **2 200 m²**. Therefore, the building in this example complies with the floor area component of Table C2.2. The fact that the Class 8 portion exceeds 1 600 m² is irrelevant for the purposes of this process. However, that portion is not permitted to exceed 2 000 m².

It should be noted that the maximum allowable volume must also be considered when determining whether the building complies with Table C2.2.

Fire resistance

Figure C2.2 Plan of building for above example

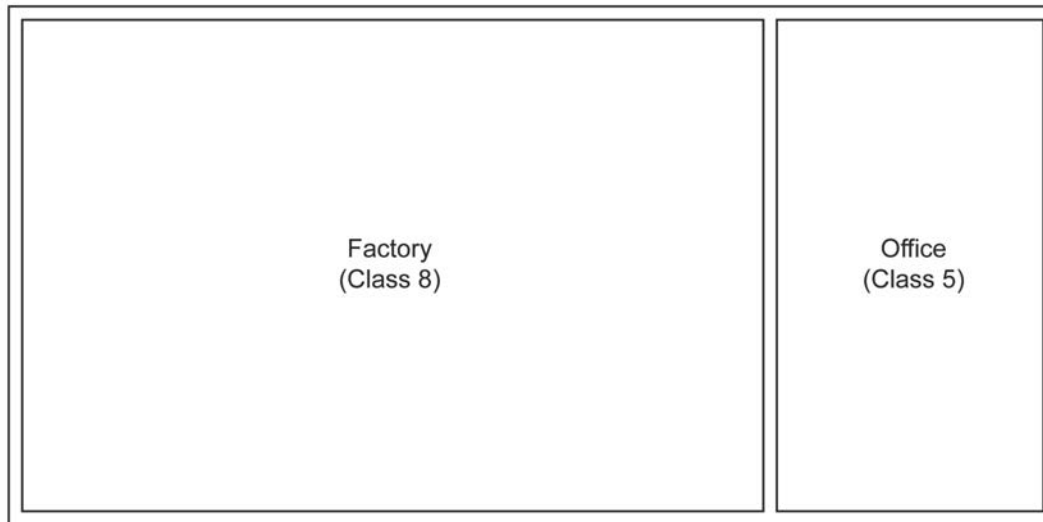

C2.3 Large isolated buildings

Intent

To grant concessions for large isolated buildings from the floor area and volume limitations.

Up to 18 000 m² floor area and 108 000 m³ volume

Under [C2.3\(a\)](#), a building with a floor area of 18 000 m² or less and a volume of 108 000 m³ or less is permitted to have fire compartments which exceed the requirements of [Table C2.2](#), if it complies with the requirements outlined below as applicable:

- Where the building is either Class 7 or Class 8—
 - it contains no more than 2 storeys; and
 - it has an 18 m wide open space around the building complying with [C2.4\(a\)](#).
- Where the building is Class 5–9 (including Class 7 and Class 8), it contains a sprinkler system complying with [Specification E1.5](#) and has vehicular access complying with [C2.4\(b\)](#).

Over 18 000 m² in floor area or 108 000 m³ in volume

Under [C2.3\(b\)](#), a building with a floor area of more than 18 000 m² or a volume of more than 108 000 m³ is permitted to have fire compartments which exceed the requirements of [Table C2.2](#) if—

- it is protected with a sprinkler system complying with [Specification E1.5](#); and
- it has vehicular access complying with [C2.4\(b\)](#).

[C2.3](#) should be read in conjunction with the smoke hazard management systems required by [Table E2.2a](#). The reason for this is that the smoke hazard management system will play an important part in occupant safety during a fire in large fire compartments.

More than one building on allotment

Where there is more than one building on the allotment, each building may have fire compartments which exceed the requirements of [Table C2.2](#), if each building complies with [C2.3\(a\)](#) or [C2.3\(b\)](#), or if the buildings are closer than 6 metres, they both must comply with [C2.3\(a\)](#) or [C2.3\(b\)](#), as applicable, as if they were one building.

If the buildings are separated by a fire wall complying with [C2.7](#), the entire building, regardless of the level of fire compartmentation, must comply with [C2.3\(a\)](#) or [C2.3\(b\)](#), as applicable.

If more than two buildings are located on the same allotment and greater than 6 m apart, each individual building must comply with [C2.3\(a\)](#) or [C2.3\(b\)](#), as applicable.

C2.4 Requirements for open spaces and vehicular access

Intent

To set the minimum requirements for open space around a building and the provision of vehicular access for the fire brigade.

The reason for the open space requirement is to minimise the risk of a fire spreading to another building.

[C2.4\(a\)](#) specifies the compliance criteria for the open space required under [C2.3](#). The open space must be wholly within the allotment. However, the open space may also include everything except what is beyond a line drawn six metres from the farthest edge of a road, river or public place adjoining the allotment.

The open space must also include the vehicular access required by [C2.4\(b\)](#), not be used for storage or processing and not be built on, except as specified.

This provision requires the making of a “performance-style” judgement. It is the responsibility of the building proponent to satisfy the appropriate authority that any buildings on the open space will not unduly impede the activities of the fire brigade, nor add to the risk of fire spreading to a building on an adjoining allotment.

[Figure C2.4](#) illustrates compliance with [C2.4](#).

The reason for the fire brigade vehicular access is to enable the brigade to intervene to fight the fire, assist with evacuation, and stop the spread of a fire to another building. The vehicular access also provides other emergency services personnel, such as ambulance officers, with the ability to access the building as necessary.

[C2.4\(b\)](#) specifies the compliance criteria for the vehicular access required by [Part C2](#).

The required vehicular access must have access from the public road system (see [C2.4\(b\)\(i\)](#)) and must have the width, height and loadbearing capacity to allow the passage in a forward direction around the entire building and parking of fire brigade vehicles (see [C2.4\(b\)\(ii\)](#) and [\(iv\)](#)).

It must also have the necessary pedestrian access to the building (see [C2.4\(b\)\(iii\)](#)). This access may be from a public road which otherwise complies with the various requirements of [C2.4\(b\)](#) (see [C2.4\(b\)\(v\)](#)).

To achieve compliance with these provisions it is advisable to check with the local fire brigade, due to the varying sizes and type of equipment and vehicles that may be required to fight a fire.

Fire resistance

Figure C2.4 Examples of compliance with C2.4

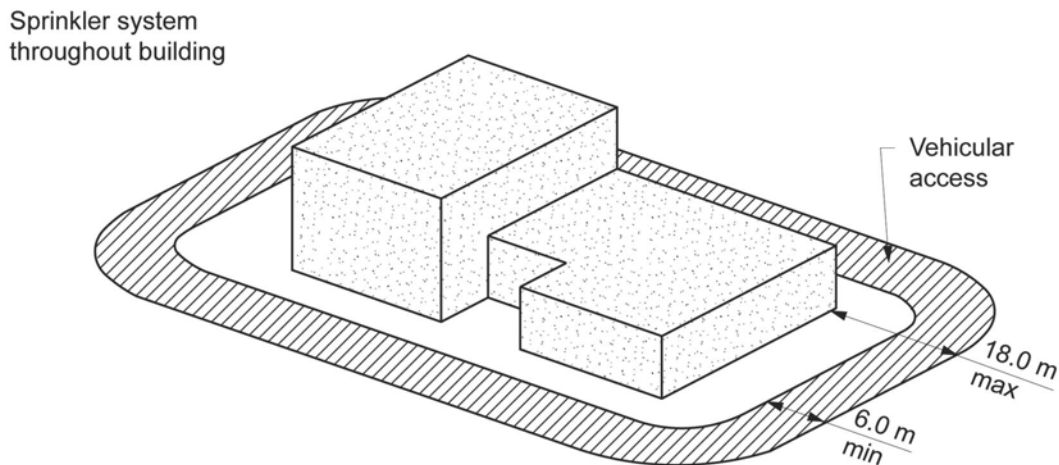
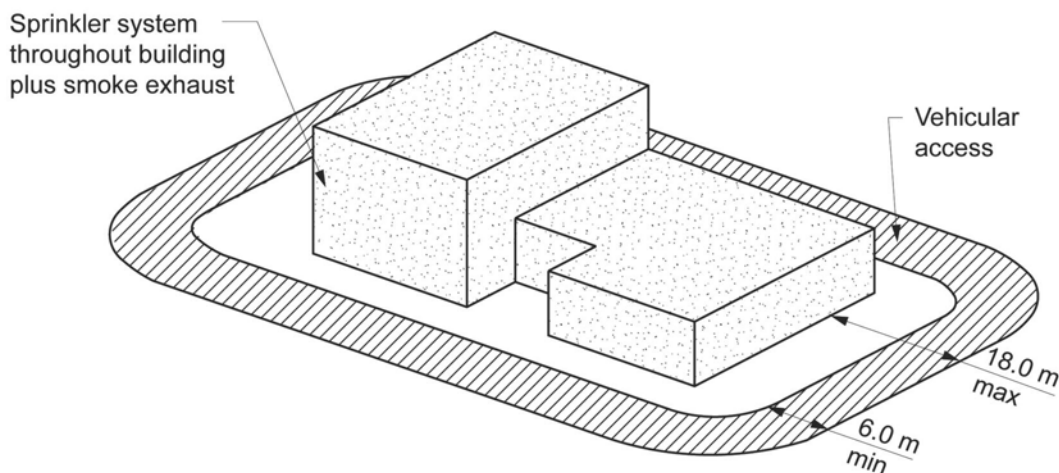
(a) Floor area 18,000 m² max, volume 108,000 m³ max(b) Floor area 18,000 m² min, volume 108,000 m³ min

C2.5 Class 9a and 9c buildings

Intent

To protect patients in a health-care building and residents in an aged care building from the spread of fire and smoke.

General

It should be noted that C2.5(a) applies to Class 9a health-care buildings. C2.5(b) only applies to Class 9c buildings.

Class 9a buildings—evacuation difficulties

Residents or patients of Class 9a buildings are often unable to evacuate a building without assistance. They may be incapable of walking or bedridden. It is important to make sure that fire and smoke only affects small areas of the building.

C2.5(a)(i) requires compartmentation for the control of smoke and fire.

C2.5(a)(ii) and (v) make it necessary to separate potential sources of fire from any patient care area. C2.5(a)(ii) requires fire compartments in Class 9a buildings. An ancillary use area in C2.5(a)(v) is deemed to be an area where there are items of equipment or materials, that have a high potential fire hazard (high fire load or fire source).

C2.5(a)(iii) and (iv) require sub-compartmentation in certain areas to allow for the staged evacuation of patients from the building. Sub-compartmentation is considered to enhance evacuation procedures, which typically require assistance to be provided to evacuees by an adequate number of staff.

Fire resistance

The requirements for smoke proof walls and doors are contained in [Specification C2.5](#).

[C2.5\(a\)\(vi\)](#) provides examples of areas covered by (v).

[Figure C2.5](#) illustrates one means of complying with [C2.5](#).

The first part of the figure shows how the administrative area of a hospital has been separated from the patient care area by a fire wall because the patient care area has a floor area of 2000 m², the maximum permitted under [C2.5\(a\)\(i\)](#).

The second part of the figure shows how the ward area must be subdivided into areas with a maximum floor area of 1 000 m² by a wall with an FRL of 60/60/60.

Some floors of Class 9a buildings may require an FRL

Compliance with [C2.5\(a\)\(iv\)\(B\)](#) may require a floor in a Class 9a building of Type B construction to have a fire-resistance level (FRL). The reason for this is that it is important to inhibit the spread of fire between floors. Separation of storeys in a Class 9a building also requires any openings in external walls to be vertically separated in accordance with [C2.6](#).

Class 9c buildings—evacuation difficulties

Residents of Class 9c buildings are often unable to evacuate without assistance. They may be incapable of walking or bedridden. It is therefore important to make sure that fire and smoke only affects small areas of the building, hence allowing residents sufficient time should evacuation be necessary.

Some walls and floors of Class 9c buildings may require an FRL

[C2.5\(b\)\(ii\)](#) requires certain walls and floors in Class 9c buildings to have a fire-resistance level (FRL). The reason for this is that it is important to inhibit the spread of fire for resident and occupant safety.

[C2.5\(b\)\(iii\)](#) allows internal walls (other than one bounding a lift or stair shaft) to have an FRL of 60/–/– because the floor is required to have an FRL of 60/60/60. Note that the FRL is only required for structural adequacy because [Table 4](#) only requires loadbearing walls in these situations to have an FRL with respect to structural adequacy. The lower FRL allowed by [C2.5\(b\)\(iii\)](#) recognises the effectiveness of the required sprinkler systems in Class 9c buildings.

Compartmentation of Class 9c buildings

The compartmentation required by fire rated and smoke proof walls for Class 9c buildings is similar to that required for Class 9a buildings.

The required compartmentation and sub-compartmentation of Class 9c buildings are to allow for the staged evacuation of residents from the building. However, successful evacuation usually depends on assistance being provided to evacuees by an adequate number of staff. The BCA provisions for Class 9c buildings are based on minimal on duty on-site staff being available at any time.

[C2.5\(b\)\(i\)](#) requires a Class 9c building to be subdivided into areas with a maximum area of 500 m² by smoke walls complying with [Specification C2.5](#). No further subdivision of the fire compartments by smoke or fire rated walls is required. This recognises the benefits of sprinkler systems that must be installed in all Class 9c buildings.

An ancillary use area in [C2.5\(b\)\(iv\)](#) is deemed to be an area where there are items of equipment or materials that have a high potential fire hazard (high fire load or fire source). The reason these walls need only be smoke proof, whereas those in a Class 9a building must have an FRL, is that Class 9c buildings must be sprinkler protected.

[C2.5\(b\)\(v\)](#) provides examples of areas covered by (iv).

Fire resistance

Figure C2.5 Plan showing one method of complying with C2.5(a) for Class 9a buildings

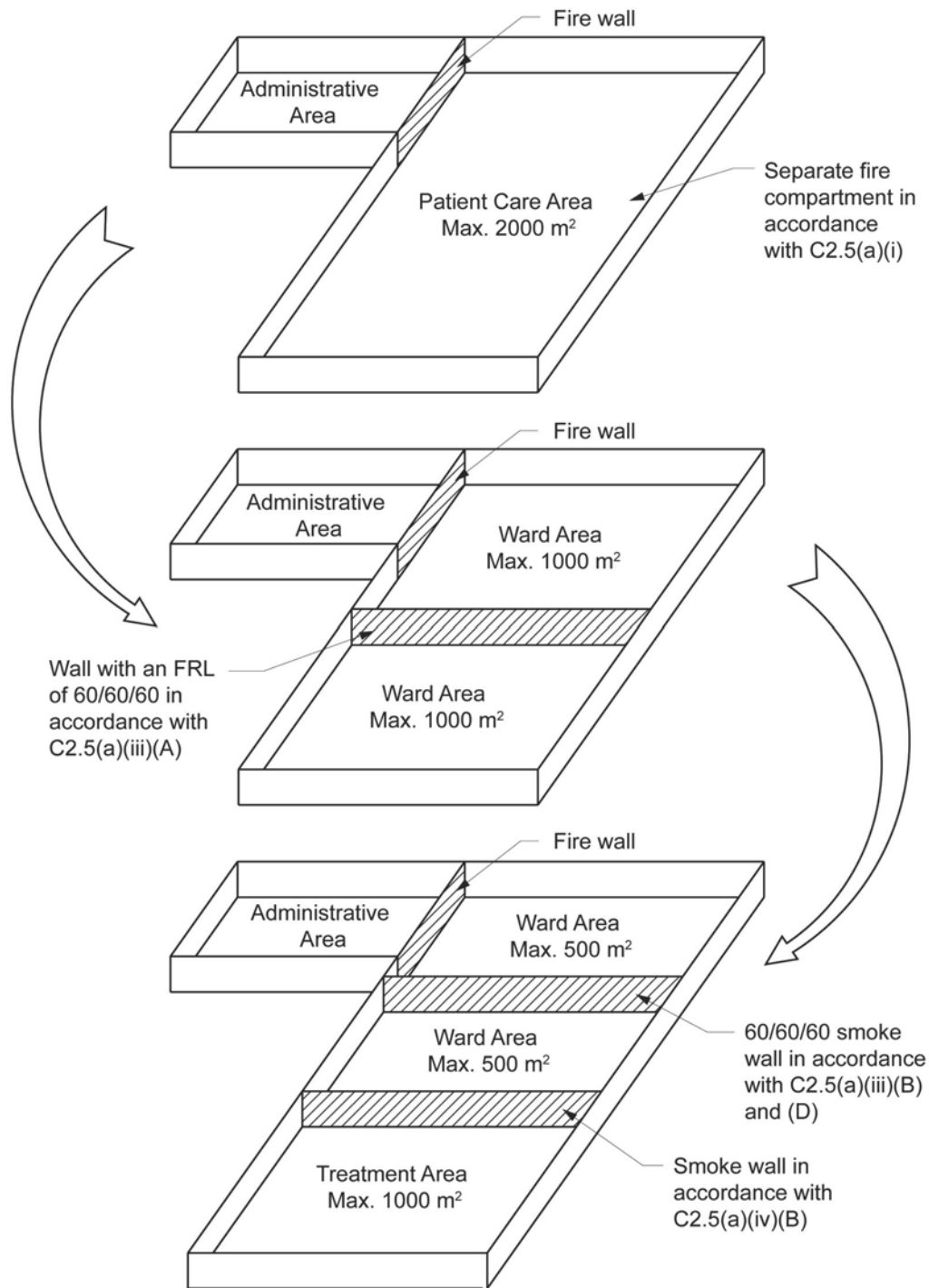

C2.6 Vertical separation of openings in external walls

Intent

To minimise the risk of fire spreading from one floor to another via openings in external walls in buildings of Type A construction.

Buildings of Type A construction

C2.6 generally applies to buildings of Type A construction and Class 9a buildings of Type B construction, because they are the only buildings required to provide fire separation between floors. This separation is achieved by the floor being required to have a fire-resistance level (FRL). It applies to openings above one another in different storeys if they are within a horizontal distance of 450 mm of each other.

Fire resistance

It does not apply to:

- sprinkler protected buildings because the sprinklers should prevent the fire developing to the stage where it could spread to the floor above;
- openings in a fire-isolated stair shaft. This is because the stair shaft is not considered to be separate storeys and it is assumed that fire spread between floors will not occur via the stairway; or
- open-deck car parks and open spectator stands. This is because it is unlikely that fire would spread between floors in these types of buildings as their open construction allows the dissipation of the effects of fire.

In addition, Class 9a buildings of Type B construction require openings in external walls to be vertically separated in accordance with C2.6 as if the building was Type A construction (see C2.5(a)(iv)). This can be achieved either by the construction methods outlined below or the installation of sprinklers in the building. The reason for this is that it is important to inhibit the spread of fire between floors in Class 9a buildings.

Protection of vertically separated openings

C2.6 requires the vertical separation of openings in external walls (see C2.6(a) and (b)) of buildings of Type A construction which do not have a sprinkler system complying with Specification E1.5 (other than a FPAA101D or FPAA101H system). The vertical separation of openings can be achieved by either of the following methods:

- a non-combustible spandrel or other non-combustible vertical construction having an overall height of 900 mm or more, extending at least 600 mm or more above the upper surface of the intervening floor, and having an FRL of 60/60/60 (see C2.6(a)(i)) as shown in Figure C2.6(1); or
- a non-combustible horizontal projection having an outwards projection from the external face of the wall of 1100 mm or more, an extension along the wall beyond the openings of at least 450 mm, and having an FRL of 60/60/60 (see C2.6(a)(iv)) as shown in Figure C2.6(2).

If the external wall of the building is a glass curtain wall, C2.6(a)(iii) contains specific provisions to stop or limit the spread of fire and smoke between the glass and the edge of the concrete floor. The details are shown in Figure C2.6(3).

Although it could be argued that the spandrel or vertical projection should have the same FRL as the floor separating the storeys, this has not been found to be necessary.

Meaning of “window or other opening”

C2.6(c) explains the meaning of the term “window or other opening” as used in C2.6(a). Basically, the term is used to describe a part of the external wall which does not have an FRL of at least 60/60/60 to limit the spread of fire from one storey to another by passing out through the window or opening and then re-entering the building through a similar opening (i.e. one without an FRL of at least 60/60/60) on the storey above. Examples of such openings include:

- windows;
- glass curtain walls;
- non-fire rated panels; and
- other parts of the wall that do not have an FRL of at least 60/60/60.

Figure C2.6(1) Section showing use of spandrel to separate external window openings

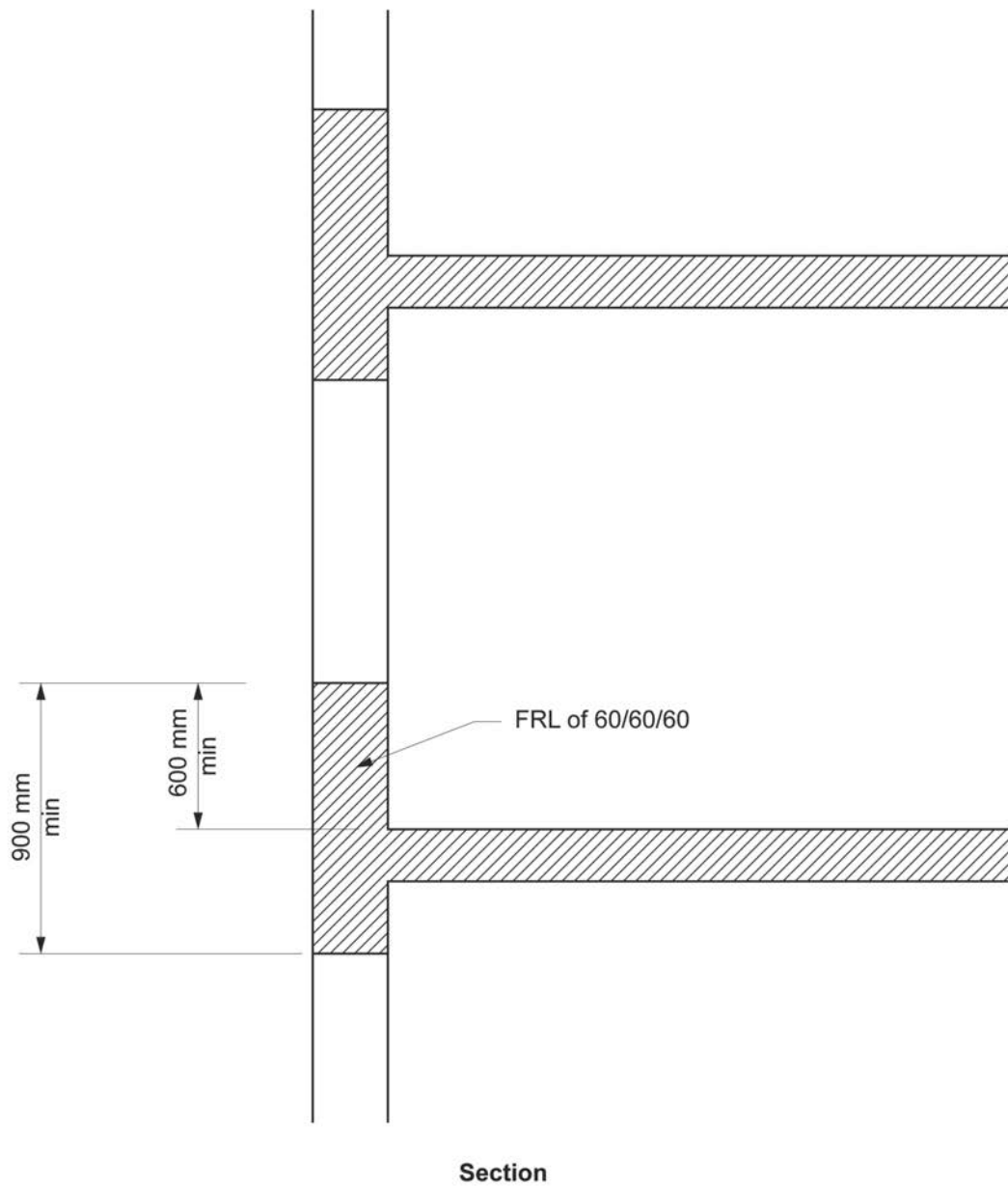

Fire resistance

Figure C2.6(2) Example showing use of slab or horizontal construction to separate external window openings

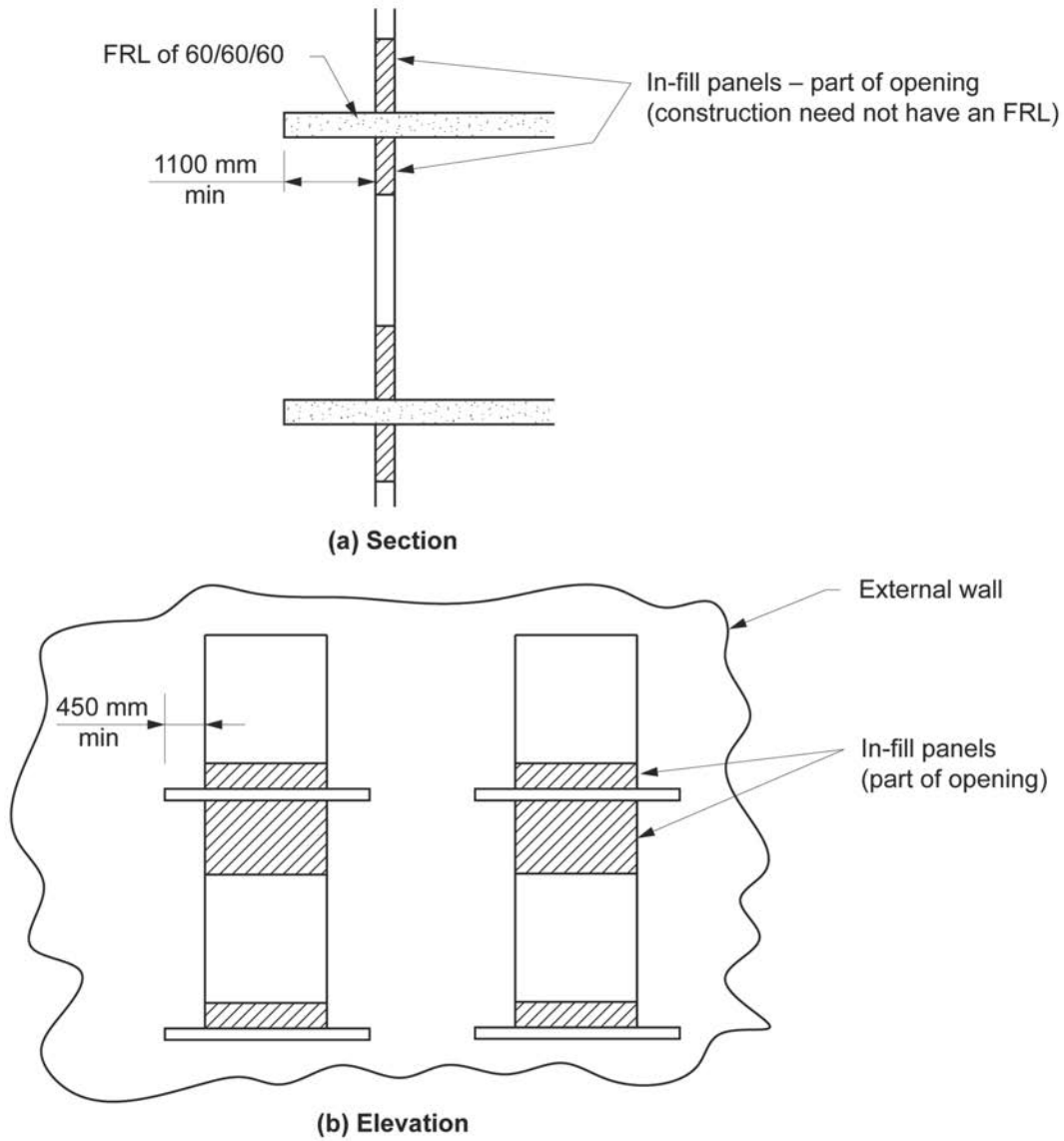

Fire resistance

Figure C2.6(3) Section showing separation of external window openings in a curtain wall

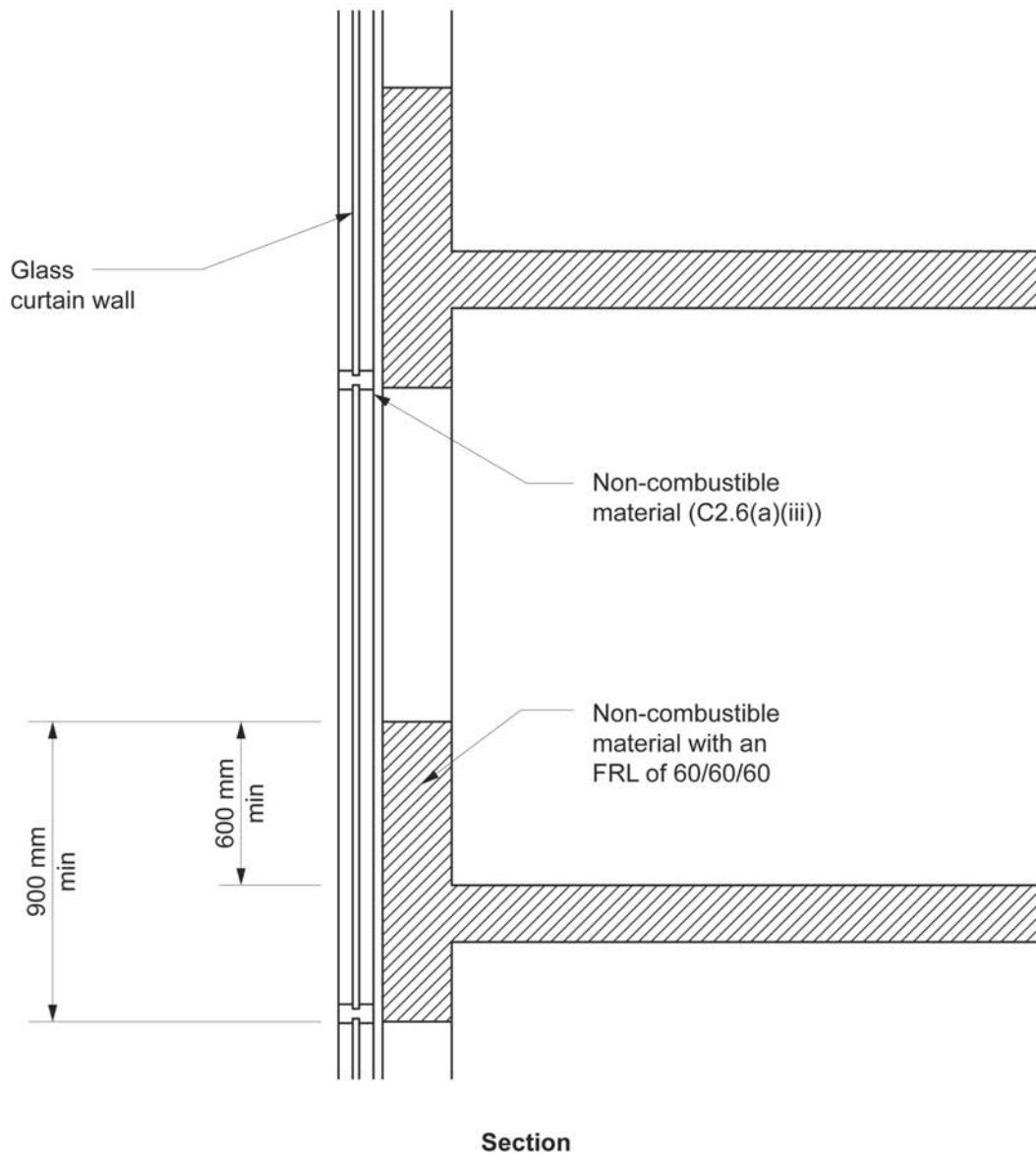

C2.7 Separation by fire walls

Intent

To explain that buildings separated by a fire wall may be considered as fire compartments or be regarded as separate buildings.

Construction

C2.7(a) outlines how a fire wall is to be constructed.

C2.7(a)(i) sets out the required FRL of a fire wall. If any part adjoining the fire wall is required to have a higher FRL, the fire wall must achieve the higher FRL. The exception occurs if an adjoining part is an open-deck or sprinklered carpark that complies with the concessions set out in Table 3.9, 4.2 or 5.2 of Specification C1.

C2.7(a)(ii) requires all openings in fire walls to not reduce the required FRL of Specification C1.1 for the fire wall, except where permitted by Part C3. In effect, this provision is referring to:

- C3.5 for doorways in fire walls;
- C3.6 for sliding doors in fire walls;
- C3.7 if the fire wall forms separation required for horizontal exits; and

Fire resistance

- [C3.15](#) for openings for service penetrations.

Figure C2.7(1) Example of method of separating a building by a fire wall in accordance with C2.7(b)(ii)

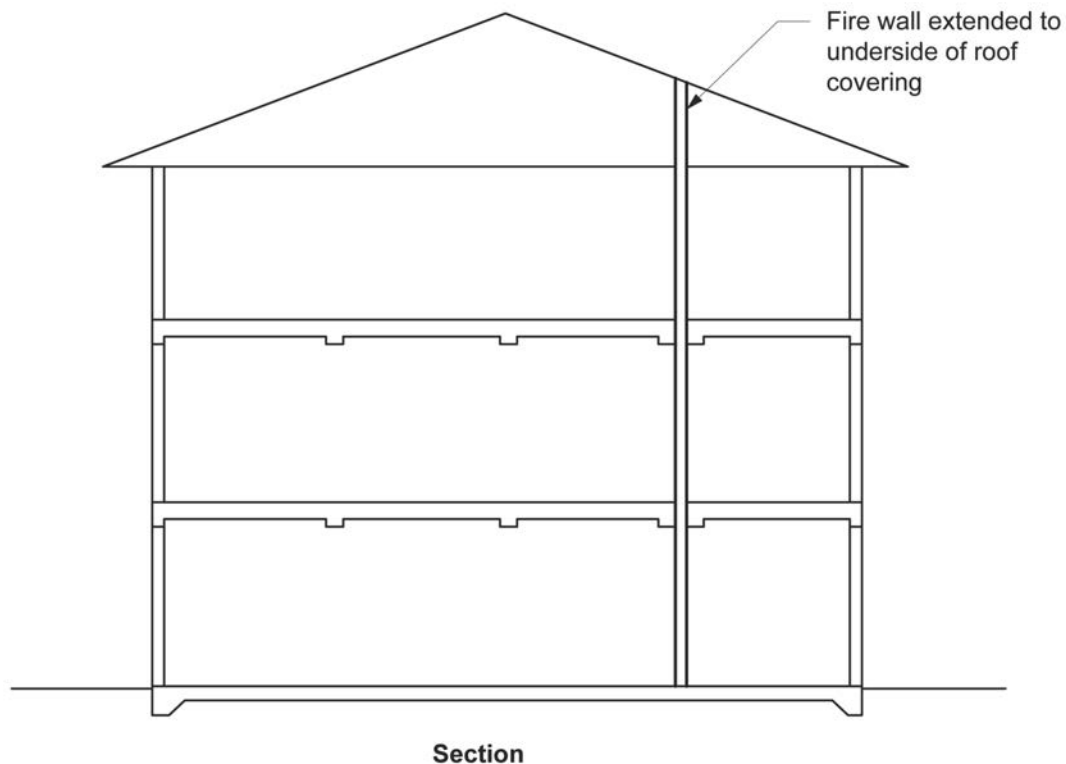

[C2.7\(a\)\(iii\)](#) indicates which building elements are permitted to pass through or cross a fire wall and prohibits the use of any building element if it reduces the fire wall's FRL below that required. Hence, elements that pass through or cross a fire wall have to be part of the fire wall's tested prototype.

[C2.7\(a\)\(iii\)](#) grants an exemption to its requirements for small roof battens and roof sarking.

Separation of buildings

[C2.7\(b\)](#) indicates the extent a fire wall divides a building into separate buildings for the Deemed-to-Satisfy Provisions of [Sections C, D and E](#) (see [Figure C2.7\(1\)](#)).

The fire wall must extend through all storeys and similar spaces which are common to the subject parts of the building, and any adjoining part of the building, through to the underside of any roof covering (see [C2.7\(b\)\(ii\)](#)).

[C2.7\(b\)](#) outlines the requirements for the extent of a fire wall that separates adjoining parts of a building where the roofs are at different levels.

If buildings, with different roof levels divided by a fire wall, are to be treated as two separate buildings, the fire wall must extend up to the underside of the highest roof or not less than 6 m above the covering of the lowest roof.

Alternatively, [C2.7\(b\)](#) allows the fire wall not to extend 6 m above the lower roof if the roof to the lower level building:

- has the FRL prescribed for the fire wall by [Specification C1.1](#) and no openings are located within 3 m of any wall located above the lower roof; or
- the lower roof is non-combustible and the part of the building below has a sprinkler system complying with [Specification E1.5](#) (other than a FPAA101D or FPAA101H system) installed.

Separation of fire compartments

[C2.7\(c\)](#) clarifies that a fire wall built in accordance with [C2.7\(a\)](#) can be considered to divide a building into different fire compartments for the purpose of [Sections C, D and E](#) (see [Figure 2.7\(2\)](#)).

Fire resistance

Figure C2.7(2) Example of a method of separating a building into fire compartments by a fire wall in accordance with C2.7(c)

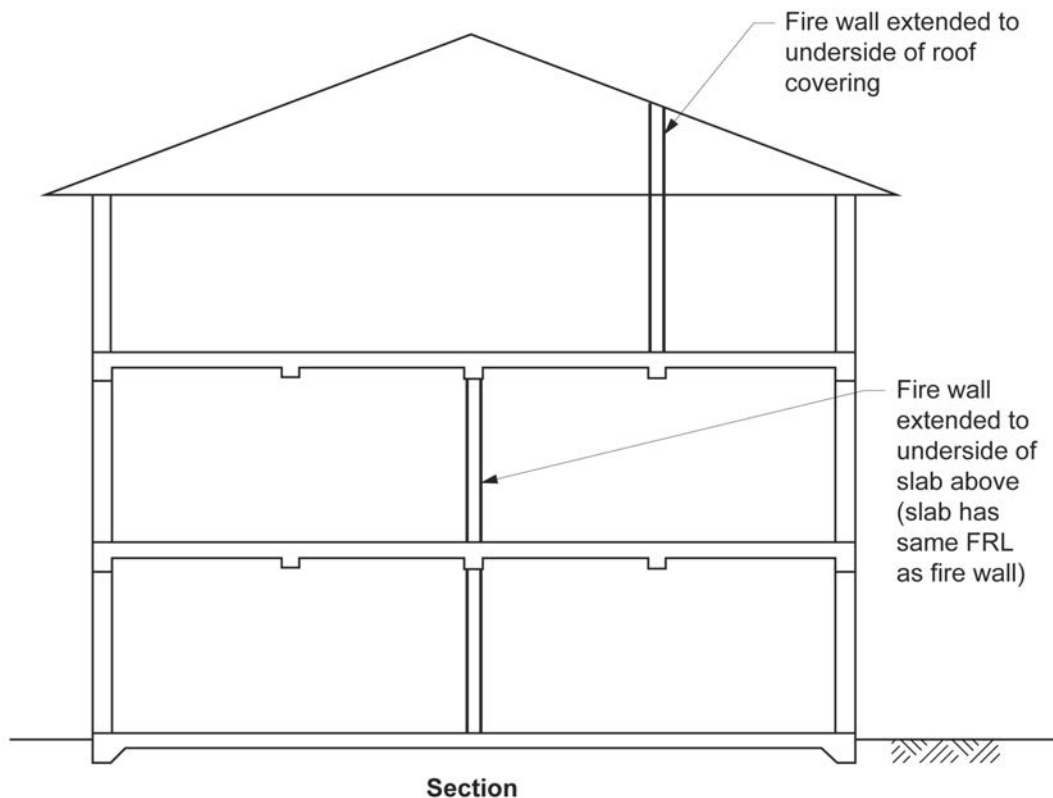

For a fire wall to compartment a building it must extend to the underside of any roof covering or between floors that have an equivalent FRL to the fire wall.

If the building is being separated into fire compartments by a fire wall have different roof levels there is no requirement to extend the fire wall to the underside of the higher roof level or above the lower roof level. This is because the fire wall serves as a means to limit the floor area of the building. When a fire wall is applied in this case, the building cannot be treated as two separate buildings for the purpose of Sections C, D and E of the BCA.

Figure C2.7(2) illustrates the case where two fire walls divide storeys but do not align, therefore not meeting the requirements of C2.7(b). In this case, the building cannot be regarded as two buildings divided by a fire wall.

Figure C2.7(3) illustrates a circumstance where a fire wall can be an external wall. This is important to note because of a possible reading of the definition of “fire wall” which indicates that a fire wall would always be an internal wall. For the purposes of Sections C, D and E, the separated building is regarded as two buildings.

C2.8 Separation of classifications in the same storey

Intent

To minimise the risk of a fire in one classification on a storey causing the failure of building elements in another classification on the same storey.

Fire spread between classifications

The fire-resistance level (FRL) required for building elements varies, depending on the expected fire load. This load is measured in the BCA by the building classification. With these differing FRLs, it is important that a fire in one classification does not cause the failure of building elements in any other classification.

There are two options to stop a fire spreading from one classification to another classification on the same storey:

- use the highest of the two fire-resistance levels (FRLs) required for each building element in that storey (see C2.8(a)); or
- place a fire wall between the two different classifications (see C2.8(b) and (c)). In a building of mixed classification C2.8(b) clarifies that for Type A and Type B construction the FRL is the higher of that specified in

Fire resistance

Table 3 or 4 but for Type C construction it is the FRL specified in Table 5. This is because the FRL for firewalls in Type C construction is the same for all Classes.

Figure C2.8(1) illustrates some examples of fire walls separating different classifications within the same storey of a building. In the first diagram, the public corridor must be fire-separated from the Class 6 part (as shown) or the Class 5 part to achieve total fire-separation between the different classifications. If a doorway is located in the fire wall, it must comply with C3.5.

Figure C2.7(3) Example of fire wall used as an external wall to separate a building in accordance with C2.7(b)(iii)

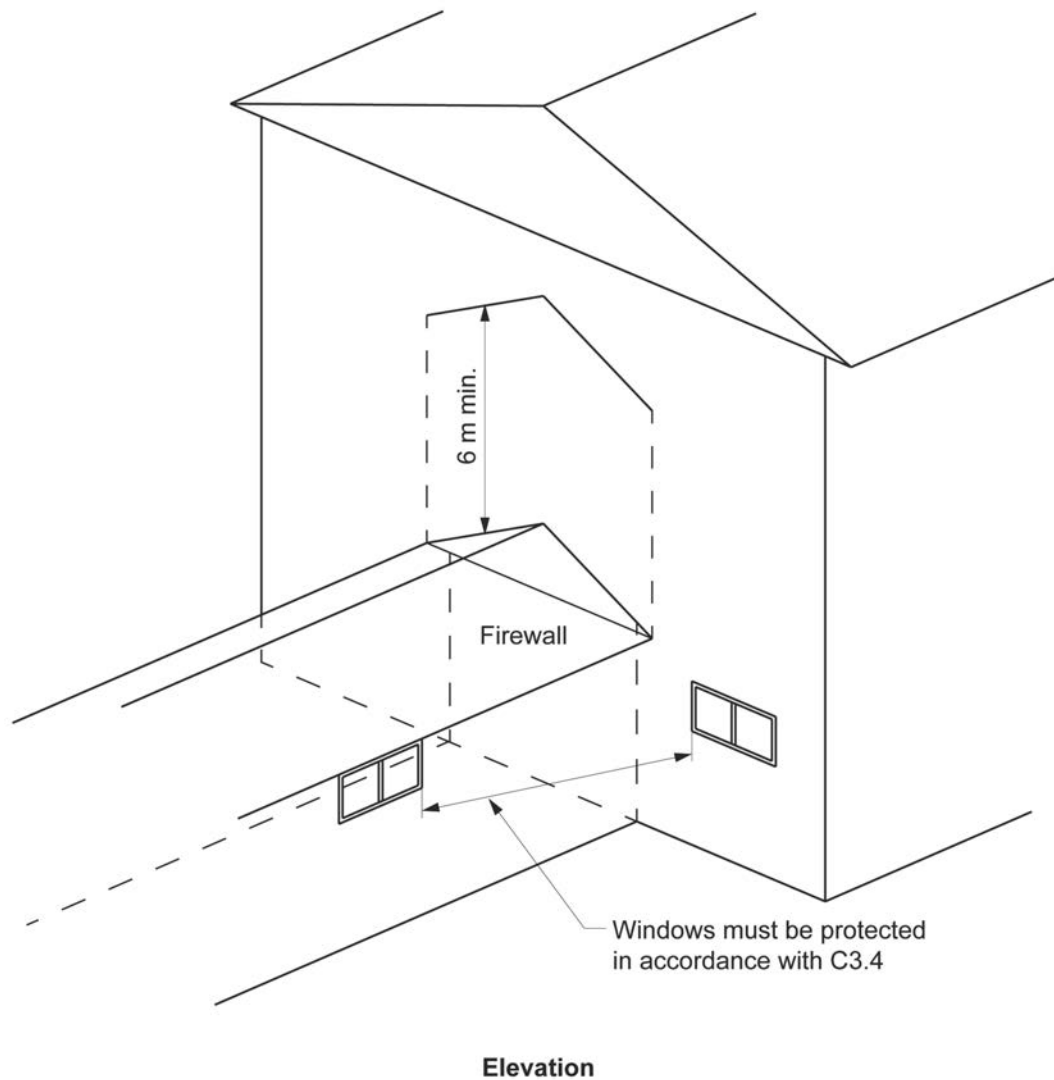

Fire resistance

Figure C2.8(1) Examples of fire wall separating different classifications in a building of Type A construction

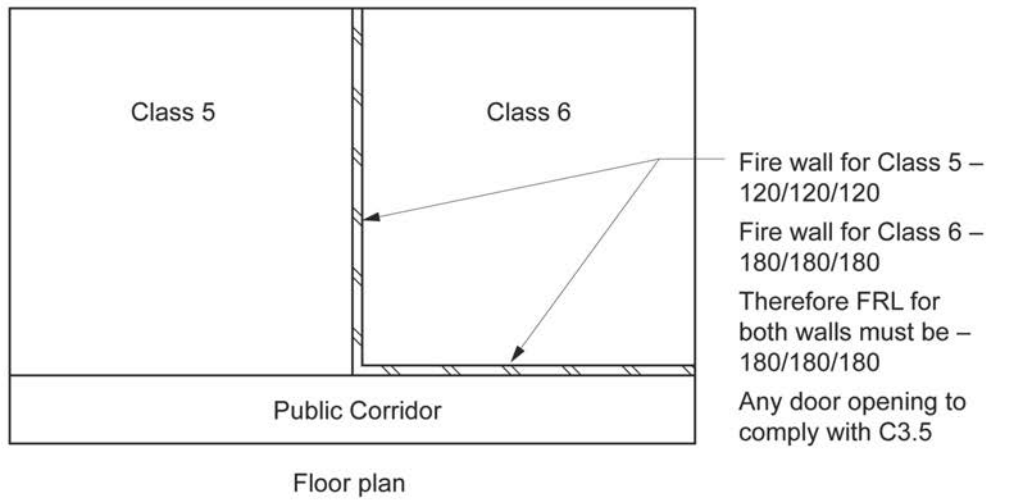

(a) Bounding a public corridor

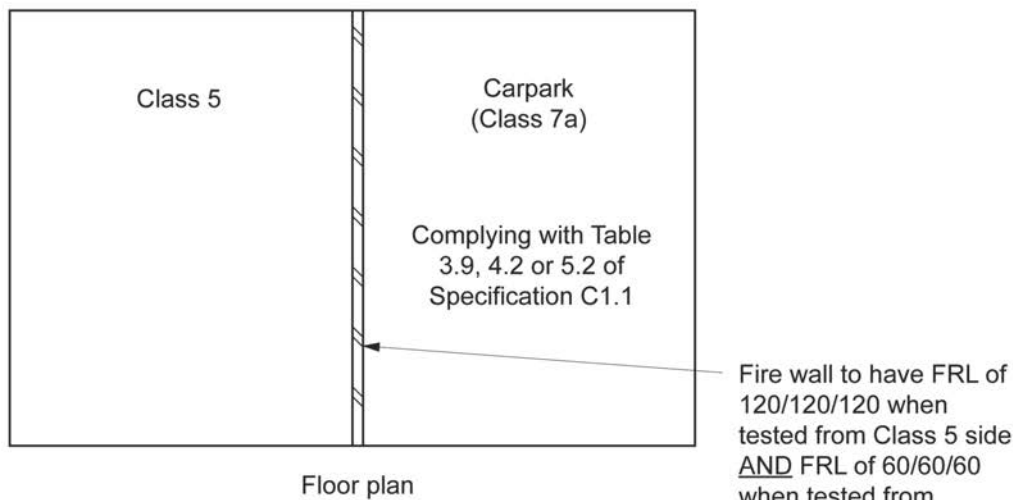

(b) Separating a carpark

The diagrams in [Figure C2.8\(2\)](#) illustrate examples of fire walls separating different classifications within the same storey of a multi-storey building and floors separating different classifications.

Fire resistance

Figure C2.8(2) Examples of fire walls and floors separating different classifications in a building of Type A construction

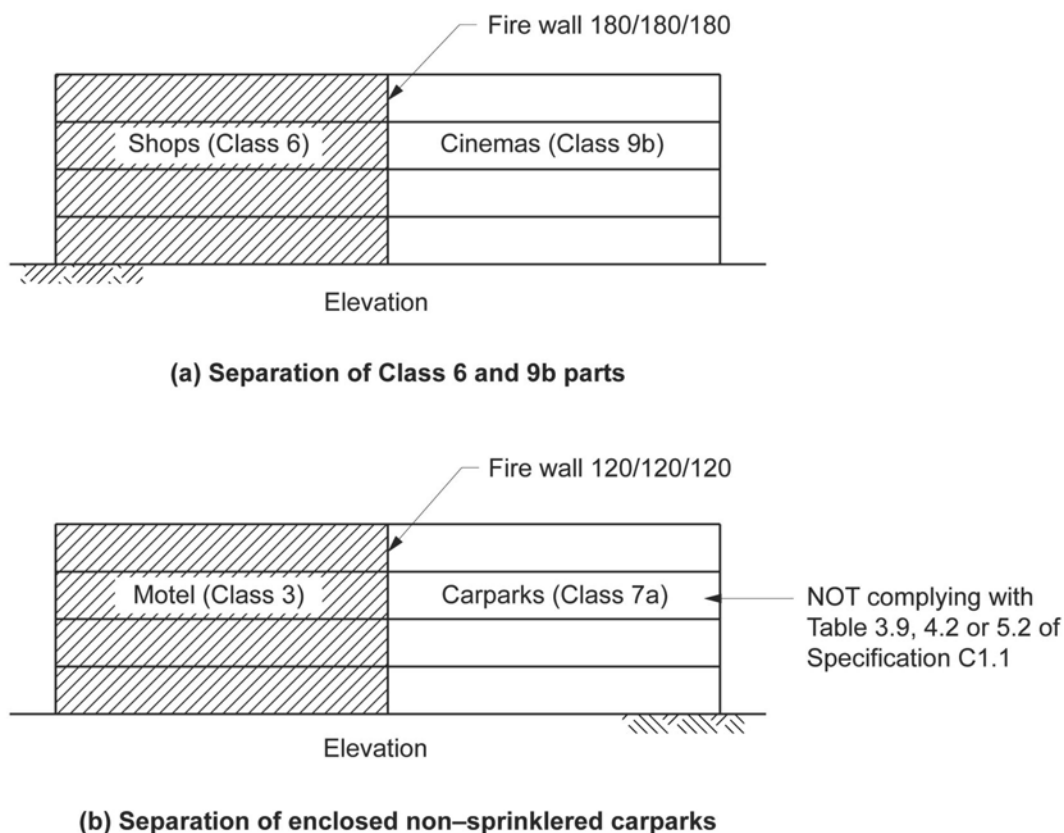

C2.9 Separation of classifications in different storeys

Intent

To minimise the risk of a fire in one classification causing the failure of building elements in another classification in a different storey.

C2.9 specifies the required separation between parts of a building which are of a different classification, situated one above the other.

The aim of C2.9 is for the fire load of a storey to determine the fire protection of the floor above it. A fire on one storey will affect the storey above to a greater degree than any storey below.

C2.9(a) sets out the requirements for buildings of Type A construction. Figure C2.9 illustrates an example of the required fire-resistance level (FRL) of floors in a 3 storey building required to be of Type A construction.

C2.9(b) sets out the requirements for buildings of Type B and Type C construction. However, note that C2.9(b) is only applicable where one of the parts being separated is Class 2, Class 3 or Class 4 and Specification C1.1 Clauses 4.1(i) and 5.1(e) require floors to be protected if the building is Class 2, 3 or 9.

Fire resistance

Figure C2.9 Example of floors separating different classifications in a building of Type A construction

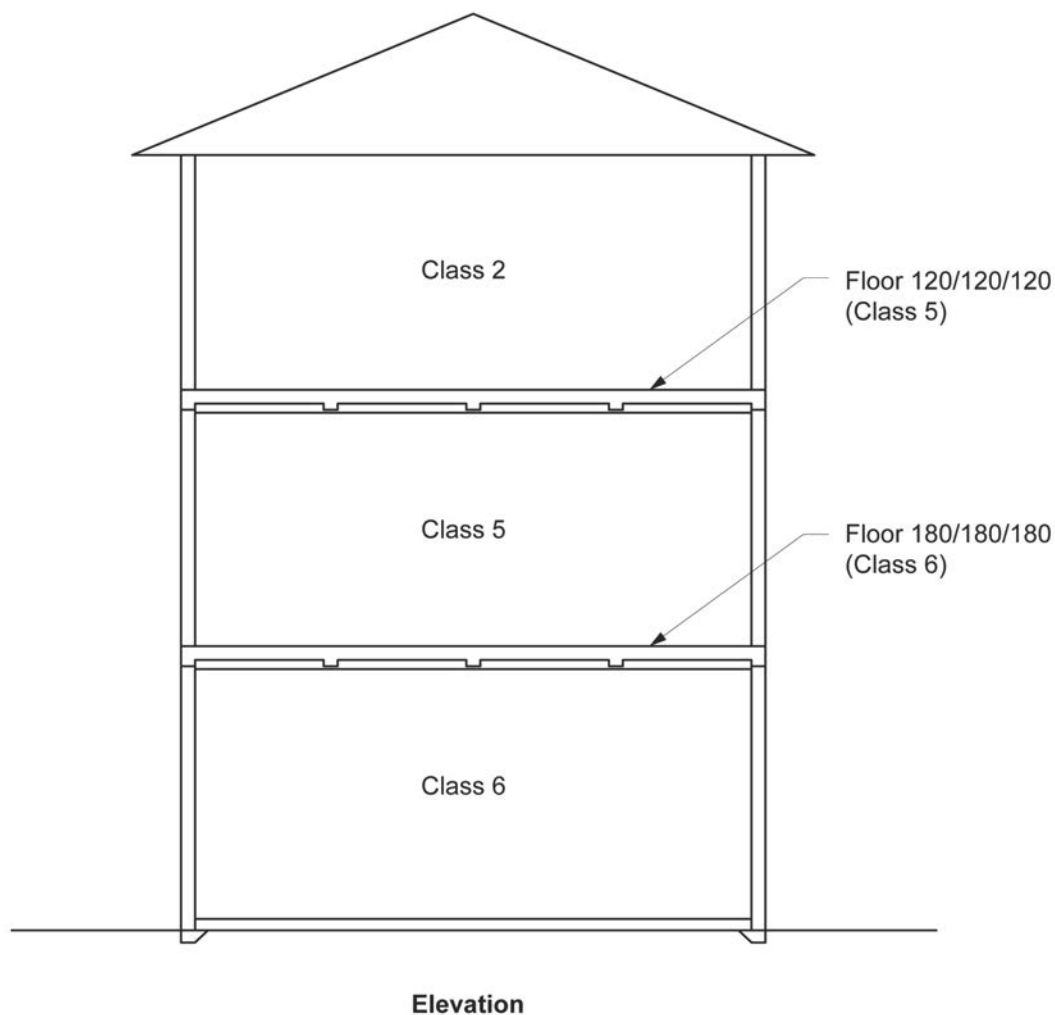

C2.10 Separation of lift shafts

Intent

To minimise the risk of a fire spreading from one floor to another floor of a building by way of a lift opening.

The approach adopted in [C2.10](#) for lift shafts is similar to that adopted by the BCA for stairway shafts.

[C2.10](#) applies to all classes of buildings and specifies the protection requirements for openings both for lift landing doors and services.

Lifts in Type A and B Construction

In any building required to be of Type A or B construction, having a lift connecting more than 2 storeys or more than 3 storeys if the building is sprinklered (other than lifts that are wholly within an atrium), the lift must be in an enclosed shaft separated from the rest of the building.

The lift shaft walls in a building of Type A construction must have the relevant fire-resistance level (FRL) prescribed by [Table 3 of Specification C1.1](#). It does not matter what Class the building is, nor whether the shaft walls are loadbearing.

In a building required to be of Type B construction, the lift shaft walls must have the relevant FRL prescribed by [Table 4 of Specification C1.1](#) if they are loadbearing. If the lift shaft walls are non-loadbearing they must be of non-combustible construction.

As all emergency lifts are required to be fire separated from the remainder of the building, [C2.10\(c\)](#) clarifies that the lift shaft is to have an FRL of not less than 120/120/120.

[C2.10\(d\)](#) only applies to fire-isolated lift shafts. Lift landing doors and indicator panels are covered by [C3.10](#). Openings for other services must comply with any other appropriate provisions in [Part C3](#).

Fire resistance

If a lift is wholly in an atrium, it is not required to be in a fire-isolated shaft. This is because the atrium comprises a single fire compartment.

Patient care and resident areas

Any lift in a patient care area in a Class 9a building, or a resident use area in a Class 9c building is to be in a fire-isolated shaft. In a Class 9a or 9c building that is required to be of Type A or B construction it is to have an FRL of 120/120/120. In a Class 9a or 9c building of Type C construction the shaft is to have an FRL of 60/60/60.

Lifts in Type C construction

Apart from emergency lifts and lifts in patient care and resident use areas, lifts need not be in a fire-isolated shaft if the building is of Type C construction. This is because such buildings are not required to have fire-rated floors or any fire compartmentation between storeys.

C2.11 Stairways and lifts in one shaft**Intent**

To maintain a safe evacuation route for people using a fire-isolated stairway, by separating the stairway shaft from the lift shaft.

Lift shafts do not offer the same fire protection to occupants as fire-isolated stairway shafts. This is because lift landing doors to shafts have no insulation properties and do not seal against smoke to the same extent as fire doors to stairway shafts. Also, many lift over-runs are places where rubbish or other combustible materials may accumulate and are therefore potential fire-sources.

C2.12 Separation of equipment**Intent**

To limit the spread of fire from service equipment having a high fire hazard or potential for explosion and to ensure emergency equipment continues to operate during a fire.

C2.12 is part of the Deemed-to-Satisfy Provisions for **CP6** and **CP7**.

The types of equipment referred to in **C2.12(a)(i)** and **(ii)** and **C2.12(c)** need to continue to operate during an emergency, such as a fire. It is therefore important to stop the spread of fire to this equipment.

The requirement under **C2.12(c)** that on-site fire pumps comply with **E1.3**, rather than **C2.12(d)**, recognises the importance of this equipment to fire-fighting.

The type of equipment referred to in **C2.12(a)(iv)** have a high explosive potential. The high temperatures and pressures associated with a boiler requires consideration for protection as opposed to a normal water heater. It is important that any fire in this type of equipment does not spread to other parts of the building.

Batteries referred to in **C2.12(a)(v)** have the potential to contain high levels of embodied energy. In a fire event, this embodied energy can contribute to fire propagation and can be difficult to extinguish. Reference to "installed in the building" means batteries hard wired into the building. This includes batteries used to provide power supply for fire safety equipment, lifts, pumps, energy storage from renewable energy sources and the like. It does not include batteries associated with removable data infrastructure, vehicles or batteries that can be readily removed or relocated (such as plug in UPS batteries).

Not all equipment is required to be protected. Examples are listed in **C2.12(b)**. This equipment is either designed to withstand high temperatures during a fire, or is required to be protected by other parts of the BCA.

Under **C2.12(d)**, the minimum fire-resistance level (FRL) for construction used to separate the equipment listed in **C2.12(a)** from the remainder of the building is 120/120/120, with –/120/30 fire doors. However, if **Specification C1.1** (particularly **Tables 3, 4 or 5**) requires a higher FRL, then that higher FRL applies.

C2.13 Electricity supply system**Intent**

To limit the spread of fire from electrical equipment and to enable the uninterrupted operation of emergency equipment during a fire.

C2.13 is part of the Deemed-to-Satisfy Provisions for **CP6** and **CP7**.

Certain types of electrical equipment have a high potential for explosion as well as fire. **C2.13(a)** requires that the doorways to sub-stations be protected with –/120/30 fire doors to avoid the spread of any fire from the electrical equipment.

Fire resistance

Some State and Territory authorities may have additional requirements for the construction of electricity sub-stations. See relevant State or Territory Appendix to the BCA.

To enable the required emergency equipment to continue to operate during any emergency, the following must be achieved:

- The main switchboard referred to in [C2.13\(b\)](#) must be separated from other parts of the building by construction having a fire-resistance level (FRL) of 120/120/120, and any door openings protected with –/120/30 fire doors.
- The electrical conductors referred to in [C2.13\(c\)](#) must comply with the appropriate sections of AS/NZS 3013—Wiring installations—Wiring systems for specific applications, or be protected by fire rated construction with an FRL of 120/120/120.

Emergency equipment is considered sustained by a main switchboard when the emergency equipment does not rely on:

- battery backup; or
- an alternative power source running through the main switchboard,

when operating in the emergency mode.

Protection of electricity supply systems

ABCB funded research determined that providing physical segregation between non-emergency equipment switchgear and emergency equipment switchgear reduces the impact of potential damage from fire by 40%. It is essential that this equipment continue to operate during a fire. [C2.13\(d\)](#) therefore requires the emergency equipment to be segregated from the other equipment in all switchboards by metal partitions designed to prevent the spread of any fault from the non-emergency equipment to the emergency equipment.

[C2.13\(e\)](#) lists the emergency equipment required by [C2.13\(d\)](#) to be separated from non-emergency equipment in a switchboard.

C2.14 Public corridors in Class 2 and 3 buildings

Intent

To minimise the risk of long public corridors in Class 2 and Class 3 buildings becoming smoke logged.

In a building fire, certain people are subject to greater risks than others, for example, the very young, elderly, people with disabilities, and those who are asleep.

In a Class 2 or Class 3 building there is a very high risk that building occupants will be asleep when a fire occurs. It is important that they be able to safely evacuate the building. To assist in the safe evacuation, long public corridors should not become smoke logged.

[C2.14](#) therefore requires the division of the public corridors into 40 metre lengths, by smoke walls and smoke doors. The details of the smoke walls are set out in [Specification C2.5](#), and details for the smoke doors are set out in [Specification C3.4](#).

The measurement of the length of the public corridor includes the sum of all connected corridor lengths that are continuous within a separate storey, smoke compartment or fire compartment.

Part C3 Protection of openings

Objective

Functional Statements

Performance Requirements

The Objective and Functional Statements for [Section C](#) are at the beginning of [Section C](#) of this Guide. The Performance Requirements for [Section C](#) are at the beginning of [Section C](#).

Deemed-to-Satisfy Provisions

C3.0 Deemed-to-Satisfy Provisions

Intent

To clarify that the requirements of [CP1](#) to [CP9](#) will be satisfied if the building complies with Parts [C1](#), [C2](#) and [C3](#), and [Parts G3](#), [H1](#) and [H3](#), if applicable.

See **Deemed-to-Satisfy Provisions** for [C1](#). The same applies here.

C3.1 Application of Part

Intent

To clarify which openings must comply with the Deemed-to-Satisfy Provisions of [Part C3](#).

Openings listed in [C3.1\(a\)](#) need not comply with the Deemed-to-Satisfy Provisions of [Part C3](#).

However, for the purposes of [C3.1\(a\)\(iv\)](#) multiple storeys within a carpark connected by openings formed by a vehicle ramp are considered to be within the same fire compartment and therefore sprinkler protection may be required under [E1.5](#).

Openings listed in [C3.1\(b\)](#) and [\(c\)](#) must comply with the relevant [Part C3](#) Deemed-to-Satisfy Provisions.

C3.2 Protection of openings in external walls

Intent

To require any opening in external walls to be protected, only where the wall is required to have an FRL, to prevent the spread of fire from the boundary of an adjoining allotment, or one building to another building on the same allotment.

[C3.2](#) applies to all Class 2–9 buildings, even those protected by a sprinkler system. The provisions only apply to openings which are exposed to a fire source feature (i.e. an allotment boundary or another building on the same allotment) and which are located in an external wall required to have an FRL (see [Figure C3.2](#)).

Any openings in the external walls of buildings separated by fire walls must comply with [C3.2](#). In this case, each building is a fire-source feature to the other building (see [Figure C3.2](#)).

Protection of openings

Openings in an external wall must be protected if within 3 metres of a side or rear boundary (see [C3.2\(a\)\(i\)](#)). Or, under [C3.2\(a\)\(ii\)](#), if they are within 6 metres of the far boundary of an adjoining road, etc, if the opening is located in a storey above, or a reasonable distance from ground level. Openings must also be protected if they are within 6 metres of another non-Class 10 building on the allotment (see [C3.2\(a\)\(iii\)](#)).

In regards to the protection of openings under [C3.2\(a\)](#), an assessment is required to determine a “reasonable” distance from ground level, on a case by case basis. Discussions with the appropriate authority may be required in this regard.

Fire resistance

Figure C3.2 Plan showing when C3.2 requires protection of openings in an external wall required to have an FRL

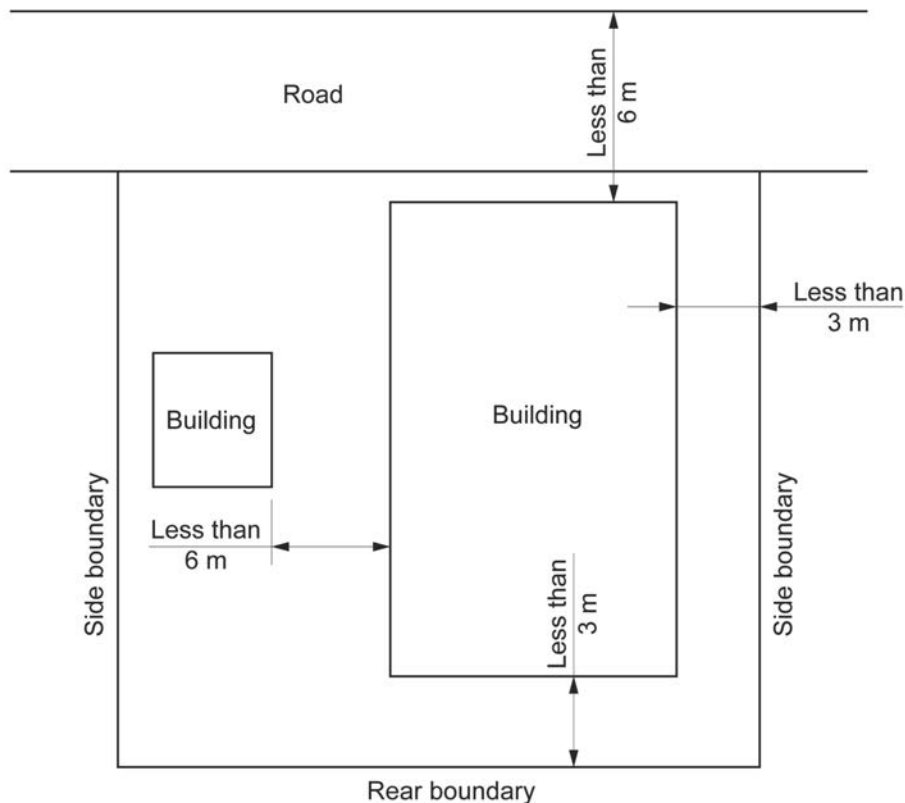

Under C3.2(b), openings in an external wall must be limited to the size specified, if the openings are required to be protected under C3.2(a). This is unless the openings are in a Class 9b open spectator stand.

C3.3 Separation of external walls and associated openings in different fire compartments

Intent

To limit the spread of fire between fire compartments through external walls and the openings in them.

Figure C3.3 illustrates the use of Table C3.3.

When the walls are at an angle of 180° or greater, the distance between them may be zero because the effects of radiant heat between the walls is negligible. In practice, the distance between such walls is likely to equal the width of the fire wall.

Sole-occupancy units in Class 2 and Class 3 buildings are not fire compartments to which C3.3 applies.

Fire resistance

Figure C3.3 Plan showing illustration of Table C3.3

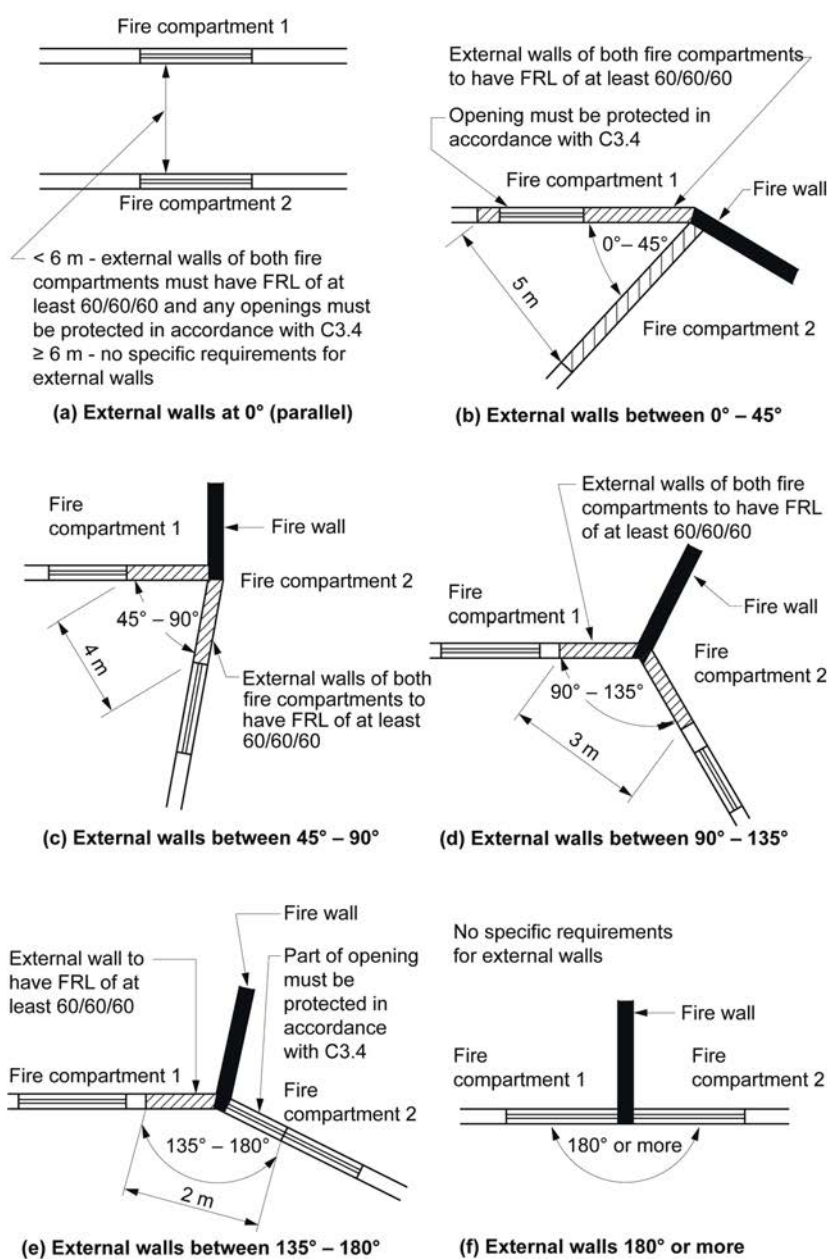

C3.3 applies to both external walls. It does not apply to fire walls separating fire compartments. (A fire wall is not always an internal wall. See Figure C2.7(3) of this Guide).

C3.4 Acceptable methods of protection

Intent
To set out acceptable methods of protection required for different types of openings in a building.

C3.4(a) applies where protection is required to doorways, windows and other openings.

C3.4(b) requires fire doors, fire windows and fire shutters to comply with Specification C3.4.

C3.4 is referred to by a number of the BCA's Deemed-to-Satisfy Provisions. Some of these provisions will specify whether or not a required sprinkler system must be internal or external. Where external wall wetting sprinklers are proposed, it may be designed using AS 2118.2, even though that Australian Standard is not referenced in the BCA. Please note that there are certain limitations that apply to AS 2118.2, such as the types of glazing applicable and location of sprinkler heads.

Examples

Fire resistance

Examples of the references to [C3.4](#) in the other Deemed-to-Satisfy Provisions include the following:

- [C3.2](#) refers to [C3.4](#) for the protection required for openings in the external walls of a building located close to a fire-source feature.
- [C3.3](#) allows the distance between openings in the external walls of a fire compartment to be closer than allowed by [Table C3.3](#) if they are protected in accordance with [C3.4](#).
- [C3.8](#) requires the protection of certain window openings in fire-isolated exits.
- [D1.7\(c\)\(ii\)](#), regarding travel from an exit point of discharge within 6 metres of an opening in an external wall.
- [D1.8](#), regarding travel past openings within 6 metres of an external stairway.
- [C3.11\(g\)\(v\)\(A\)](#) requires the protection of certain windows in bounding walls of Class 2 and 3 buildings and Class 4 parts as an option.

[C3.4\(a\)\(i\)](#) clarifies that wall-wetting sprinklers are only to be used with doors that are self-closing or automatic closing.

[C3.4\(a\)\(ii\)](#) clarifies that wall-wetting sprinklers are only to be used with automatic closing windows or permanently closed windows.

For openings other than doorways or windows, [C3.4\(a\)\(iii\)\(A\)](#) clarifies that internal or external wall-wetting sprinklers are not recognised as an acceptable method of protection for voids under the Deemed-to-Satisfy Provisions. Conventional wall-wetting sprinklers need a medium or surface to act on. An opening consisting of a void does not provide such a medium or surface.

C3.5 Doorways in fire walls

Intent

To maintain the integrity of fire walls by limiting the spread of fire through doorways.

If the opening in the fire wall is for a horizontal exit, refer to [C3.7](#).

When a doorway is installed in a fire wall, to achieve the same fire separation as the wall, [C3.5\(a\)](#) allows the use of:

- two fire doors, one on each side of the doorway;
- two fire shutters, one on each side of the doorway;
- one fire door and one fire shutter, one on each side of the doorway;
- a single fire door; or
- a single fire shutter.

(See [C3.5\(a\)\(i\)](#), [C3.5\(a\)\(ii\)](#) and [C3.5\(a\)\(iii\)](#))

In each option, the single fire door or shutter, or any of the combinations of the two, must have the same fire-resistance level (FRL) as the fire wall. (This is except for the insulation criterion, which must be at least 30 minutes)

When determining the required FRL of the fire door or shutter, [Clause 6 of Schedule 5](#) states that non-loadbearing elements need not comply with the structural adequacy criterion. A fire door or shutter is normally regarded as a non-loadbearing element.

Example

Consider the case of a fire wall required to have an FRL of 240/240/240. After taking into account the concession allowed by [Clause 6 of Schedule 5](#), [C3.5](#) allows any doorway in that wall to be protected by:

- two –/120/30 fire doors, one on each side of the doorway;
- two –/120/30 fire shutters, one on each side of the doorway;
- a –/120/30 fire door and a –/120/30 shutter door, one on each side of the doorway;
- a single –/240/30 fire door; or
- a single –/240/30 fire shutter.

Closure of fire doors and shutters

[C3.5\(b\)](#) states that any fire door or shutter required under [C3.5\(a\)](#) must be either self-closing or automatic-closing. If automatic closing, it must be initiated by smoke detectors, or (in specified circumstances) any other detector deemed suitable in accordance with AS 1670.1 (see [C3.5\(c\)](#)). It is important that the detector used is suitable for the location and type of fire likely to occur. The suitability of detectors can be determined by reference to AS 1670.1. These detectors must also be in accord with the relevant provisions of AS 1670.1, and located as specified in [C3.5\(c\)](#).

Fire resistance

Under [C3.5\(d\)](#), the activation of any other required suitable fire alarm system (including a complying sprinkler system), in either of the fire compartments separated by the fire wall, must operate the automatic closing of the fire door or shutter.

A smoke detector can give false alarms if the atmosphere contains particles such as steam or other vapours that obscure vision (eg kitchens, carparks, etc). If a smoke detector is likely to give a false alarm due to the atmospheric conditions, then a heat detector should be used to comply with [C3.5\(c\)](#).

[Figure C3.5](#) illustrates the requirements of [C3.5](#).

Figure C3.5 Plan illustrating automatic fire doors or automatic fire shutters installed in an opening in a fire wall in accordance with C3.5

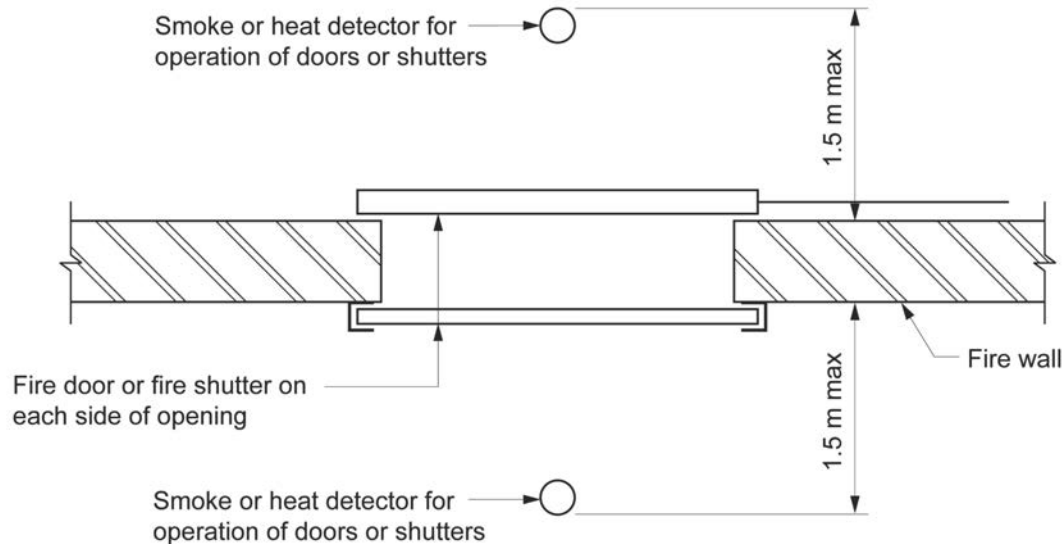

C3.6 Sliding fire doors

Intent

To avoid danger to occupants caused by the automatic closing of a sliding fire door.

It is an acceptable and frequently used option to protect an opening in a fire wall by a sliding fire door held open by an electromagnetic device. However, sliding fire doors tend to be quite large and heavy, presenting a potential danger to occupants passing through while it is closing. To reduce the danger to building occupants the rate of the door's closing is limited and must be by the deactivation of an electromagnetic device (see [C3.6\(a\)\(i\)](#)).

In the event of a power failure, the electromagnetic device must also fail-safe so that the door closes thereby maintaining the integrity of the fire wall (see [C3.6\(a\)\(ii\)](#)).

Warning lights and signs are required to be installed on each side of the door by [C3.6\(a\)\(iii\)](#) and [\(iv\)](#) to indicate the presence and operation of the fire door. [C3.6\(b\)](#) and [\(c\)](#) requires the electromagnetic device to deactivate and the warning system to operate when there is a fire in a fire compartment on either side of the fire wall. This process must be activated by either smoke detectors or heat detectors (in specific circumstances) installed in accordance with the relevant provisions of AS/NZS 1905.1 and AS 1670.1 (see [C3.6\(b\)](#)).

The activation of any other required suitable fire alarm system (including a complying sprinkler system) in either of the fire compartments must also cause the automatic closing of the fire door (see [C3.6\(c\)](#)).

A smoke detector can give false alarms (see comments on [C3.5](#)). Heat detectors complying with [C3.6\(b\)](#) should be used in these circumstances.

C3.7 Protection of doorways in horizontal exits

Intent

To provide occupants using a horizontal exit with the same protection as those using a fire-isolated exit.

Types of doors permissible

Fire resistance

The use of fire shutters are prohibited in a horizontal exit by D2.19(b)(ii). Similarly, D2.19(b)(iii) does not permit sliding doors to be used as horizontal exits.

There are some concessions to these prohibitions (see D2.19).

The fire doors used for horizontal exits, as referred to in C3.7, must swing in the direction of travel (as required by D2.20). If the horizontal exit applies in both directions (i.e. the doorway may be used to escape from either fire compartment to the other), the installation of two doors may be necessary (see Figure C3.7).

Buildings other than Class 7 and 8

Unless it is located in a Class 7 or Class 8 building, a doorway which is part of a horizontal exit must be protected by a single fire door complying with C3.7(a)(i).

Two fire doors in Class 7 and 8

The reason for allowing two fire doors to be installed in a doorway in Class 7 and Class 8 buildings is because single fire doors with the required fire-resistance level (FRL) are heavy and difficult to open. In combination, the two fire doors must achieve an equivalent FRL to the fire wall.

If two fire doors are installed in a doorway in a Class 7 or Class 8 building, it may be necessary to install a small lobby to allow for the swing of the doors (see Figure C3.7).

C3.7(b) has the same requirements for fire doors as C3.5. Refer to the comments made in C3.5 for application to C3.7(a).

Figure C3.7 Plans showing horizontal exits in a fire wall

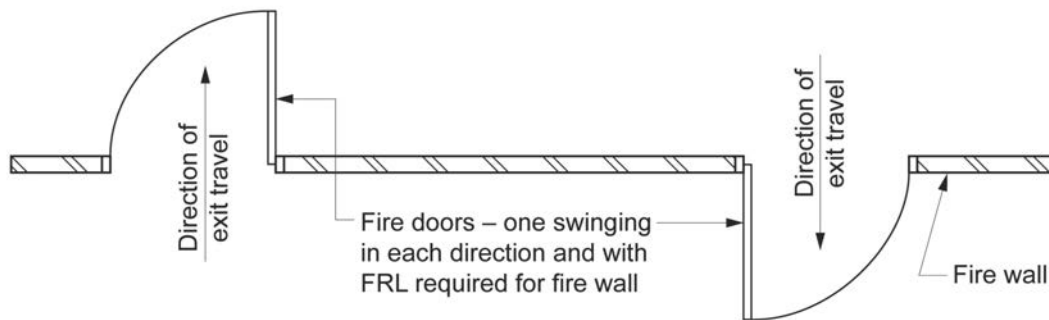

(a) Exit travel in both directions

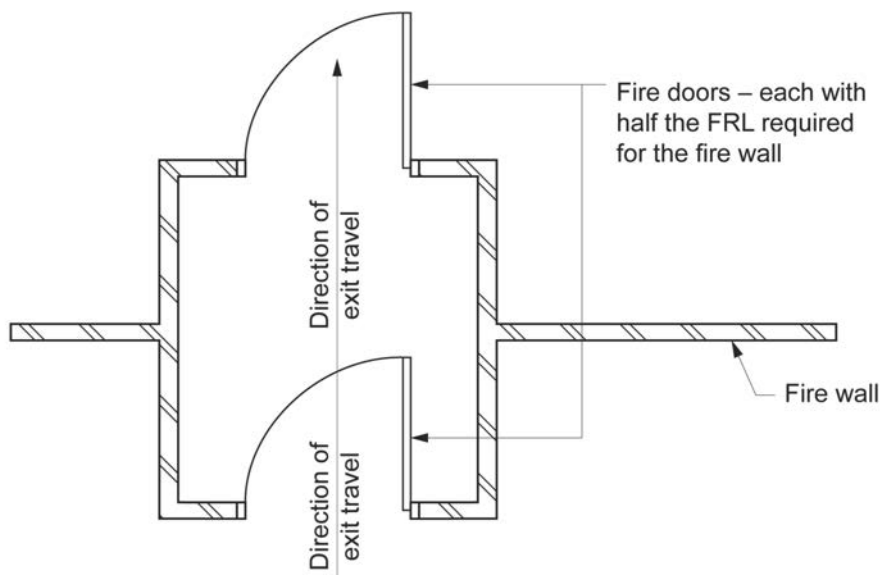

Class 7 or 8 building (use of 2 doors)

(b) Exit travel in one direction

C3.8 Openings in fire-isolated exits

Intent

To maintain the integrity of a fire-isolated exit and to protect people using fire-isolated exits by providing adequately protected door and window openings.

Doorways

Any doorway leading into a fire-isolated exit is a possible source of fire and/or smoke spreading into that exit. The spread of fire or smoke into a fire-isolated exit is dangerous.

It is therefore important that such doorways are protected by fire doors. These fire doors must be self-closing (see [C3.8\(a\)](#)) or automatic-closing initiated by smoke detectors or (in specified circumstances) heat detectors (see [C3.8\(b\)](#)).

[C3.8](#) has the same requirements for fire doors or shutters as [C3.5](#). Refer to the comments made in [C3.5](#) for application here.

[C3.8](#) does not apply to a doorway leading from a fire-isolated exit to a road or open space, because failure of such a doorway is not affected by a fire in the building. However, note that such a doorway may require protection to comply with [C3.2](#).

Windows

[C3.8\(d\)](#) only applies to a window which could expose an evacuating person or fire fighter to radiant heat from a fire in the building. Therefore, [C3.8\(d\)](#) does not apply to a window exposed to another window within the same fire-isolated exit.

If a sprinkler system is chosen as the means of protection in accordance with [C3.4](#), the sprinkler heads must be located on the side of the window outside the exit.

A window subject to the requirements of [C3.8\(d\)](#) may also require protection from an external fire to comply with [C3.2](#).

C3.9 Service penetrations in fire-isolated exits

Intent

To maintain the integrity of a fire-isolated exit and to protect the people using them by providing protection to service penetrations.

[C3.9](#) minimises the number of service penetrations into a fire-isolated exit by only allowing the services specified. Each of the services listed in [C3.9\(a\)](#) and [\(b\)](#) is essential to maintain a safe environment within the fire-isolated enclosure.

Under [C3.9\(c\)](#), the water supply for fire-fighting may be located within a fire-isolated exit. Hydrants located within a fire-isolated enclosure allow the fire brigade to set up their hoses and other equipment in a protected area before attacking the fire.

The location of any service penetrations into the fire-isolated exit permitted by [C3.9](#) must not reduce the exit width required by [D1.6](#).

[C3.9](#) should be read in conjunction with [D2.7](#), which deals more generally with installations in exits and paths of travel.

C3.10 Openings in fire-isolated lift shafts

Intent

To maintain the integrity of a fire-isolated lift shaft and to limit the spread of fire from one floor of a building to another floor by way of a lift shaft.

Any doorway leading into a fire-isolated lift shaft could assist the spread of fire. Any spread of fire into the shaft could endanger the lives and safety of the people using the lift, and lead to the spread of fire to another part of the building. Therefore, it is important that such doorways be protected by fire doors.

AS 1530.4 (the Australian Standard for the Standard Fire Test) requires lift landing doors to be tested for integrity. Such doors are usually of metal construction, and are not required to satisfy any insulation criteria.

Lift indicator panels in excess of 35 000 mm² are considered to represent a sufficient risk of spreading fire into a lift shaft. Indicator panels exceeding this size require backing by material having a fire-resistance level (FRL) of -/60/60.

Small panels of 35 000 mm² or less are unlikely to lead to the spread of fire into the shaft. This exemption is similar in principle to those allowed by [C3.1](#) for minor openings such as control joints, weep holes, subfloor ventilators and the like.

C3.11 Bounding construction: Class 2 and 3 buildings and Class 4 parts

Intent

To maintain the performance of a wall bounding any sole-occupancy unit or public corridor in Class 2 or Class 3 buildings; and any sole-occupancy unit in a Class 4 part.

Protection of doorways

To maintain the fire performance of walls surrounding a sole-occupancy unit and corridors used as egress routes in Class 2 and Class 3 buildings, [C3.11\(a\)](#) and [\(b\)](#) requires the following doorways to be protected:

- between sole-occupancy units and any public corridor, public hallway or the like (see [C3.11\(a\)\(i\)](#));
- between sole-occupancy units and any room not within a sole-occupancy unit, such as a common laundry, common sitting room and the like (see [C3.11\(a\)\(ii\)](#));
- between sole-occupancy units and any landing of an internal, non-fire-isolated stair serving as a required exit (see [C3.11\(a\)\(iii\)](#));
- between sole-occupancy units (see [C3.11\(a\)\(iv\)](#));
- between a room not in a sole-occupancy unit (such as a common laundry, common sitting room and the like) and any public corridor, public hallway or the like (see [C3.11\(b\)\(i\)](#)); and
- between a room not in a sole-occupancy unit (such as a common laundry, common sitting room and the like) and any landing of an internal, non-fire-isolated stair serving as a required exit (see [C3.11\(b\)\(ii\)](#)).

To maintain the fire performance of walls surrounding a sole-occupancy unit in a Class 4 part of a building, [C3.11\(c\)](#) requires the doorways to the unit to be protected.

Fire protection required for doorways

The degree of fire protection required by [C3.11\(d\)](#) for doorways to sole-occupancy units in Class 2 and Class 3 buildings and Class 4 parts is dependant upon the types of construction.

[C3.11\(d\)\(i\)](#) applies to all Class 2 and Class 3 buildings and Class 4 parts in buildings of Type A construction, except those Class 3 buildings specified in [C3.11\(d\)\(iii\)](#).

[C3.11\(d\)\(ii\)](#) applies to all Class 2 and Class 3 buildings and Class 4 parts in buildings of Type B or Type C construction, except those Class 3 buildings specified in [C3.11\(d\)\(iii\)](#).

[C3.11\(d\)\(iii\)\(A\)](#) or [\(B\)](#) only applies to Class 3 residential care buildings fitted with a sprinkler system complying with [Specification E1.5](#). A Class 3 residential care building that does not meet these requirements, must comply with [C3.11\(d\)\(i\)](#) or [\(ii\)](#) as applicable.

[C3.11\(d\)\(ii\)](#) requires that the door be self-closing to make sure that the door is closed during a fire. The requirement for such doors to be self-closing does not apply to a Class 3 residential care building which meets the requirements of [C3.11\(d\)\(iii\)\(A\)](#).

Openings other than doorways

Under [C3.11\(e\)](#), openings other than doorways in internal walls which are required to have a fire-resistance level (FRL) for integrity and insulation are permitted only if they do not lower the wall's fire-resisting performance.

Automatically closing doors

Doors required by [C3.11\(d\)](#) may be automatic-closing, initiated by smoke detectors or (in specified circumstances) any other detector deemed suitable in accordance with AS 1670.1 (see [C3.11\(f\)\(i\)](#)). The suitability of detectors can be determined by reference to AS 1670.1. Refer to [C3.5](#) for door operation requirements as they apply to doors under [C3.11](#).

Path of travel to an exit

[C3.11\(g\)](#) applies, in a Class 2 or Class 3 building only, where a path of travel is along an open balcony, landing or the like and it does not provide a person evacuating with a choice of travel in different directions to alternative exits. If this path of travel passes an external wall of another sole-occupancy unit (see [C3.11\(g\)\(i\)](#)) or a room which is not within a sole-occupancy unit (see [C3.11\(g\)\(ii\)](#)), the external wall must be constructed in accordance with [C3.11\(g\)\(iii\)](#), have any doorways protected in accordance with [C3.11\(g\)\(iv\)](#), and any window or other openings protected in accordance with [C3.11\(g\)\(v\)\(A\)](#) or [\(B\)](#).

The reason for the above construction is to provide building occupants trying to evacuate with protection from radiant heat and flames whilst passing the unit that is on fire.

C3.12 Openings in floors and ceilings for services

Intent

To limit the spread of fire through service openings in floors and ceilings required to resist the spread of fire.

[C3.12](#) applies to floors and ceilings in buildings of Type A, B and C construction.

The performance of a fire resisting element may be compromised if service penetrations are not adequately protected. The method of protection should ensure the fire resisting capabilities of the element being penetrated is maintained. In buildings of Type A construction, the service may be within a fire resisting shaft or protected in accordance with [C3.15](#). In buildings of Type B and C construction the service may be within a shaft that does not reduce the fire resistance of the element it penetrates or it must be protected in accordance with [C3.15](#).

C3.13 Openings in shafts

Intent

To maintain the fire performance of the floor by limiting the spread of fire through openings in shafts.

[C3.13](#) only applies to buildings of Type A construction, because the other types of construction do not require service shaft walls to have a fire-resistance level (FRL).

[C3.13](#) sets out the detail of the protection required in different circumstances to prevent the spread of fire from one floor to another floor by way of a shaft.

C3.14 * * * * *

In BCA 1990, this provision was performance-based. In subsequent editions of the BCA the provision is covered by the Performance Requirements. [C3.14](#) has been left blank, rather than renumber subsequent clauses.

C3.15 Openings for service installations

Intent

To maintain the fire performance of building elements by limiting fire spread by way of service penetrations.

[C3.15](#) sets out a number of requirements for protection of service openings. These include:

- The use of tested prototypes in accordance with AS 4072.1 and AS 1530.4 (see [C3.15\(a\)](#)).
- Ventilation and air-conditioning ducts complying with AS 1668.1 (see [C3.15\(b\)](#)).
- The use of [Specification C3.15](#) for metal pipes systems (excluding pipe seals or the like), sanitary plumbing, wire or cable, or clusters of wires or cables, electrical switches, or outlets or the like.

[C3.15](#) considers the protection of openings in elements that are providing a barrier to the spread of fire and are thus required to have an FRL. The elements of an FRL that provide the barrier to spread of fire are insulation and integrity and that protecting an opening in an element an FRL for structural adequacy is unnecessary. For this reason, [C3.15](#) only applies to an element required to have an FRL with respect to integrity or insulation.

Tested systems permitted

[C3.15\(a\)\(i\)](#) quite clearly permits the use of tested systems. To comply with this Deemed-to-Satisfy Provision it is necessary for the appropriate authority to be satisfied that the proposal is identical to a tested prototype. AS 1530.4 includes a number of methods of reporting the test results. These include—

- a test report.
- a regulatory information report.
- a test certificate.

Only the test report and regulatory information report contain sufficient information to allow the appropriate authority to be satisfied that the proposal is identical with the tested prototype or differs from the prototype in accordance with AS 4072.1.

It should be noted that the provision only applies to the service where it penetrates the building element. Although AS 4072.1 and AS 1530.4 requires a tested penetration to extend a specified distance beyond the penetration opening for the purpose of carrying out the test, the NCC only requires the building element and the part of the service penetrating that element to be identical with the tested prototype or differs from the prototype in accordance with AS 4072.1.

Fire resistance

Example

Consider a service penetration consisting of a plastic pipe passing through a concrete floor to a hand basin. AS 1530.4 requires the tested prototype service pipe to extend 2 m above the floor. However, due to the height of the hand basin above the floor, the pipe is unlikely to extend more than say 800 mm. C3.15(a)(i) allows this configuration provided it is identical to the tested prototype where the service pipe passes through the floor or differs from the prototype in accordance with AS 4072.1.

Variation from tested systems for metal piping systems

C3.15(a)(ii) allows a concession from the insulation criteria of a tested prototype specified in C3.15(a)(i). The concession only applies for penetrations by metal piping systems where the service pipe is not located within an exit (see C3.15(a)(ii)(D)) and is at least 100 mm from any combustible building element for a distance of 2 m from the penetration of the building element (see C3.15(a)(ii)(B)). To ensure that fire is not spread via the conduction of heat from the metal pipe, it is important that the service pipe be located so that combustible material cannot be located within 100 mm of the pipe for a distance of 2 m from the penetration (see C3.15(a)(ii)(C)). One method of achieving this would be to place a guard around the pipe.

In the case of a floor waste, it would not be possible to ensure that no combustible material is located within 100 mm of it. Therefore, C3.15(a)(ii) is unlikely to apply to floor wastes.

Approval of other types of penetrations

Specification C3.15 does not apply to larger diameter electrical cables (i.e. where the opening is larger than those specified in Clause 5(a) and (b) of 2000 mm² or 500 mm²). This does not mean that larger diameter electrical cables cannot be approved under C3.15. Larger diameter electrical cables can be approved under C3.15(a)(i)(A) (i.e. a tested system), C3.15(a)(i)(B) where in accordance with AS 4072.1, or if necessary, as a Performance Solution.

Gas pipes can be approved under C3.15(a) or, if necessary, as a Performance Solution.

C3.16 Construction joints**Intent**

To limit the spread of fire between building elements required to be fire-resisting.

To avoid the spread of fire between fire compartments or to another building, construction joints between building elements are normally packed with fire retardant material.

A number of proprietary products are suitable for this purpose, having previously been tested in accordance with AS 1530.4 to demonstrate they have achieved the required fire-resistance level (FRL). The test only needs to record the failure criteria of integrity and insulation. C3.16 does not require structural adequacy criteria to be achieved, as it is not part of the AS 1530.4 test for these types of materials.

C3.17 Columns protected with lightweight construction to achieve an FRL**Intent**

To prohibit columns with lightweight fire protection from lowering the fire-resistance levels (FRLs) of other building elements.

If lightweight fire protection has been inadequately applied to a column, there is an increased risk that the column will transmit heat to another building element (such as a floor or ceiling) through which it passes. The effect is that the column can cause a reduction in the fire-resistance level (FRL) or resistance to the incipient spread of fire of the elements through which it passes. This can result in the spread of fire. To eliminate this potential problem, it is necessary to use a system tested in accordance with AS 1530.4.

Specification C1.1 Fire-resisting construction

Deemed-to-Satisfy Provisions

1 Scope

Intent

To clarify that [Specification C1.1](#) contains requirements for fire-resisting construction of building elements.

Note that [Specification C1.1](#) applies only to the Deemed-to-Satisfy Provisions of the BCA. If a Performance Solution is used to satisfy a Performance Requirement, it is not necessary to comply with [Specification C1.1](#).

[Parts C1, C2, C3, D1, D2, G2, G3](#) and [H1](#) of the BCA also contain requirements for building elements to be fire-resisting and to have a fire-resistance level (FRL).

2 General Requirements

2.1 Exposure to fire-source features

Intent

To define how a building element may be exposed to a fire-source feature.

Fire-source feature

Refer to the definition in [Schedule 3](#) on the term “fire-source feature”.

A fire-source feature is a possible fire-source external to the building from which fire could spread into the building. It may be an allotment boundary or another building on the allotment from which fire could spread to the subject building.

[Clause 2.1](#) does not consider a building element to be exposed to a fire-source feature if it is shielded from the fire-source feature by another part of the building which:

- has an FRL of 30/–/– or more, and is not transparent or translucent;
- is less than 15 metres above another building on the allotment. Parts of a building more than 15 metres above another building are not deemed to be affected by fire; or
- is below the level of the finished ground at every relevant part of a side or rear boundary.

[Figure Spec C1.1\(1\)](#) illustrates some of the exemptions from the exposure to a fire-source feature.

Figure Spec C1.1(1) Part of a building not exposed to a fire-source feature

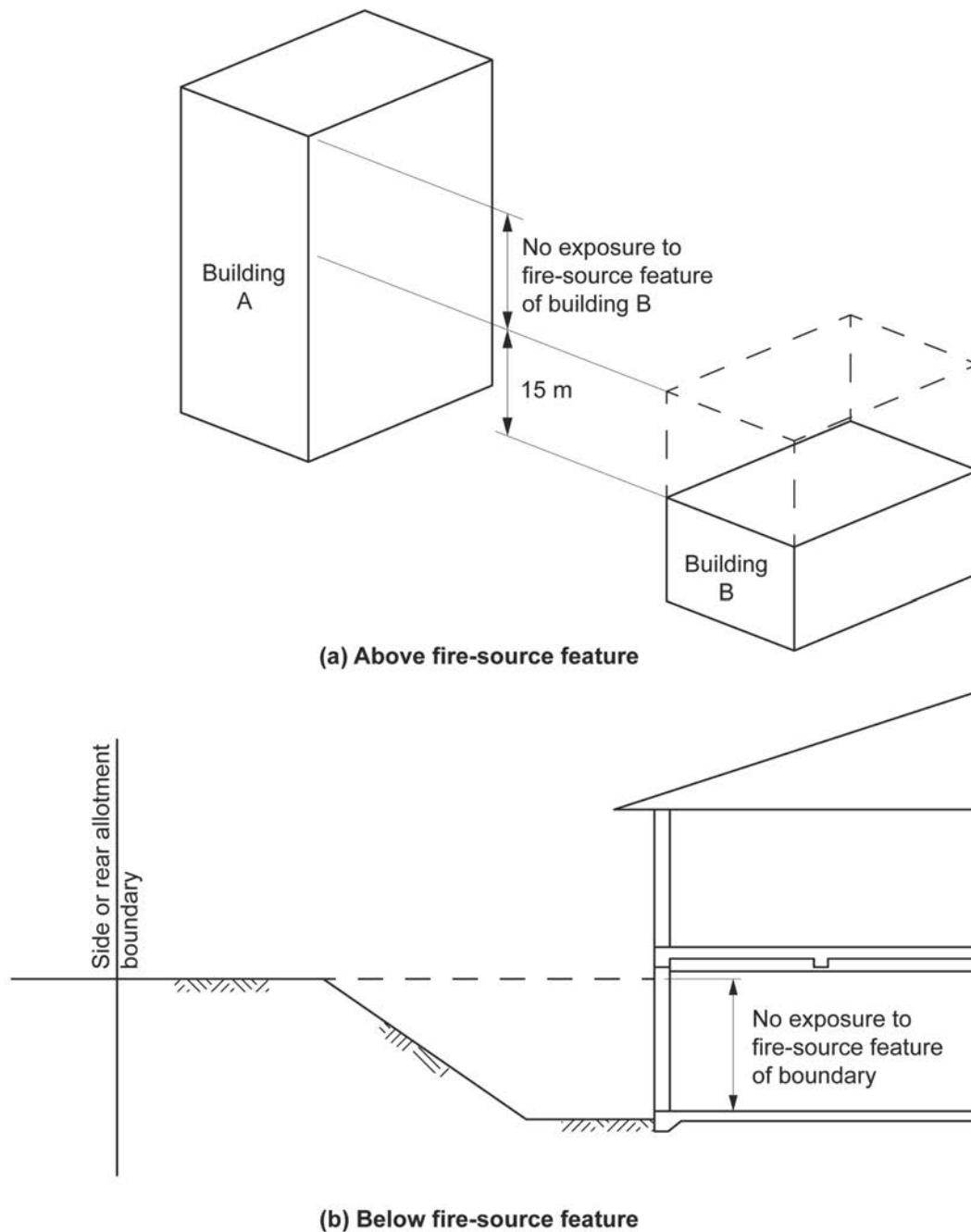

The building element must have an FRL required for the closest part of the element exposed to the fire-source feature (see [Clause 2.1\(c\)\(i\)](#)).

Alternatively, the building element may have a varying FRL according to the individual distance of each section of the building element from the fire-source feature (see [Clause 2.1\(c\)\(ii\)](#)).

[Figure Spec C1.1\(2\)](#) illustrates the alternatives for an external loadbearing wall of a Class 5 building required to be of Type A construction.

2.2 Fire protection for a support of another part

Intent

To minimise the risk that a building element required to have a fire-resistance level (FRL) will fail during a fire due to the failure of another element required to give it vertical or lateral support.

Support of building elements with an FRL

Fire resistance

[Clause 2.2\(a\)](#) sets out the requirements for the fire protection of building elements that provide lateral or vertical support to another building element. This is because a building element with an FRL is usually dependent on the support to maintain its FRL.

Accordingly, [Clause 2.2\(a\)](#) does not apply to elements that support ceilings required to have a fire-protective covering or a resistance to the incipient spread of fire. Nor to an element required to be non-combustible.

Exceptions of building elements

[Clause 2.2\(b\)](#) lists a number of exemptions to [Clause 2.2\(a\)\(ii\)](#) and [\(a\)\(iii\)\(B\)](#).

The lateral support for the types of wall referred to in [Clause 2.2\(b\)\(i\)](#) is considered unnecessary in these cases, because [Clause 5.1\(b\)](#) allows the use of brick veneer walls, and [C1.11](#) enables the prevention of outward collapse of certain external walls by specifying the connection of panels to the building's frame.

The inherent fire resistance of the supports included in [Clauses 3.9](#), [4.2](#) and [5.2](#) is considered adequate in the carpark covered by each clause. It should be noted that compliance with the relevant Table is necessary in order to comply with the relevant clause.

[Clause 2.2\(b\)\(iii\)](#) exempts roofs providing lateral support to other building elements. This is because of a concession within [Clause 3.5](#) for Type A construction. In addition, there is no requirement for Type B and C construction, principally because such buildings are generally low rise.

[Clause 2.2\(b\)\(iv\)](#) exempts certain columns, as listed in [Clause 2.5](#), from having an FRL.

Under [Clause 2.2\(b\)\(v\)](#) a fire wall or fire-resisting wall referred to should not collapse because it is supported by another building element on the other side of the wall.

Figure Spec C1.1(2) Plan showing alternative methods of complying with Table 3

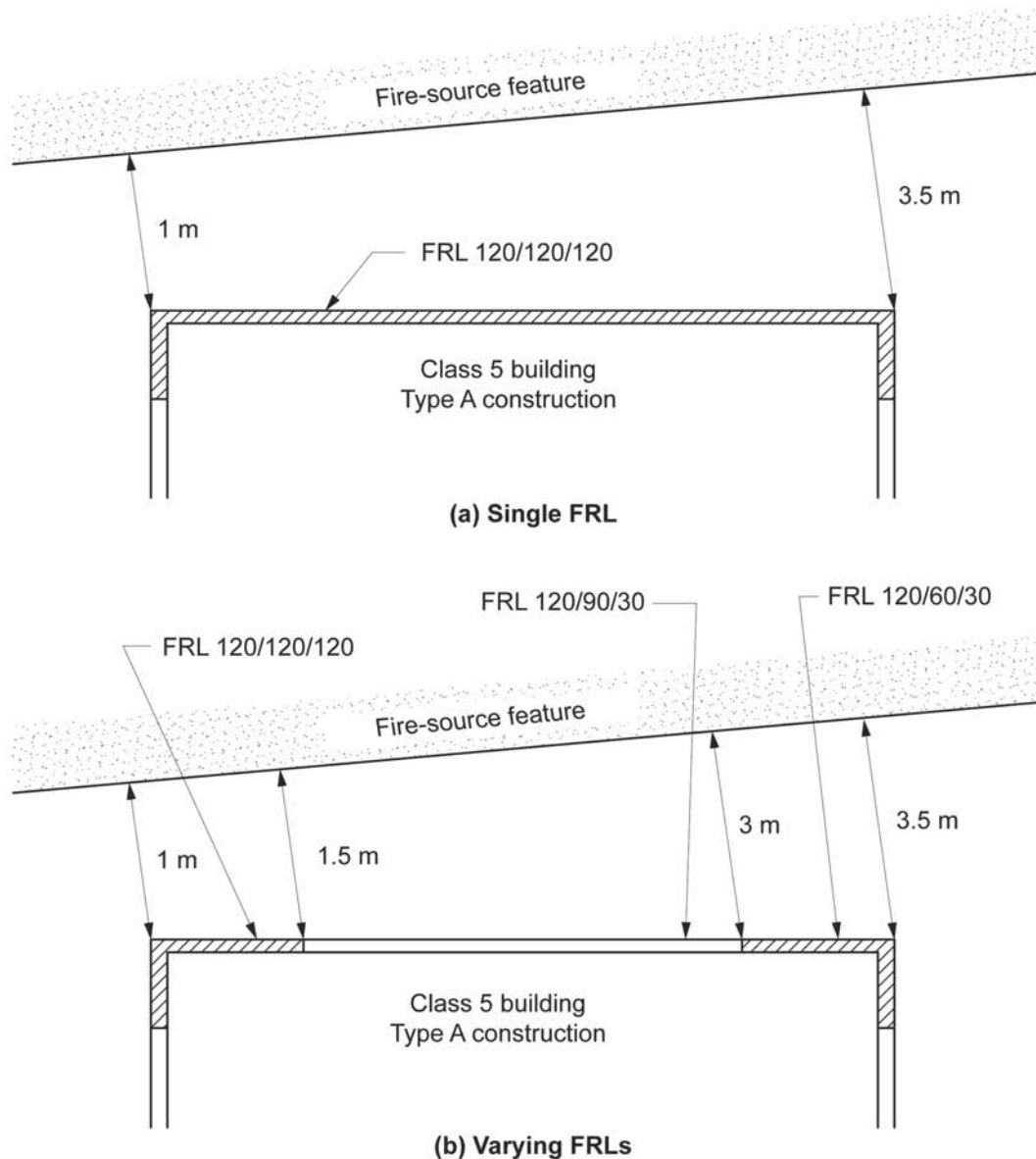

2.3 Lintels

Intent

To minimise the risk that the failure of a lintel over an opening in a wall required to have a fire-resistance level (FRL) will result in the failure of the wall during a fire.

A lintel must have the same FRL as the part of the building containing it. This is unless it does not contribute to the support of a fire door, fire window or fire shutter. Otherwise, the failure of the lintel during a fire could cause the collapse of all, or part, of the wall.

Clause 2.3 only applies to a lintel required by the Deemed-to-Satisfy Provisions to have an FRL.

Clauses 2.3(a) and (b) contain some concessions for small openings where the failure of the lintel would not result in a major collapse of the wall and lead to the spread of fire to another building.

2.4 Method of attachment not to reduce the fire-resistance of building elements

Intent

To minimise the risk that the method of attaching or installing a finish, lining, ancillary element or service installation

Fire resistance

will compromise the fire-resistance of a building element.

[Clause 2.4](#) prohibits a required FRL of a building part from being reduced by the attachment or installation of facings, finishes, ancillary elements or the installation of ducting or any other service.

The reason for controlling this is due to the potential for changes to the fire performance of a building element via attaching or installing another element.

2.5 General concessions

Intent

To permit the use of certain building practices known to provide acceptable levels of fire safety.

The concessions contained in [Clause 2.5\(a\)](#) allow a steel column to not have an FRL in one and, in some cases, two storey buildings.

The basis for this concession is the low rise of such buildings. In many cases, the columns form the legs of a portal frame, with the roof being non-fire rated. In such a case, there would be little benefit in fire rating the column when the roof beams are not rated.

Because of the importance of the structural integrity of a common wall or fire wall in limiting the spread of fire, the concession for steel columns providing lateral support does not apply.

The concessions contained in [Clause 2.5\(b\)](#) permit a reduced FRL in timber columns in single storey buildings. One method of determining the FRL of a timber column is to use the charring rate of the type of timber in the column.

The structures on a roof referred to in [Clause 2.5\(c\)](#) are not likely to lead to the spread of fire, especially as they are required to be non-combustible. The intent of [Clause 2.5\(c\)\(ii\)\(E\)](#) is to specify that the concession does not apply to structures that contain units that in turn contain flammable or combustible liquids and gases.

The curtain walls referred to in [Clause 2.5\(d\)](#) must be non-combustible and protected by an external wall-wetting sprinkler system. When such construction is used, protection is provided from fire spreading to the subject building. For the term “curtain wall”, see [Schedule 3](#). For the purposes of this provision, glass is regarded as non-combustible.

Balconies, verandahs and the like do not generally add a significant fire load to a building. Therefore, they are not required to be in compliance with [Table 3](#), [4](#) or [5](#). This is provided that occupants are not put at risk during an evacuation because the only means of egress is by way of the balcony, verandah or the like.

Also, if the building is of Type A construction, the balcony, verandah or the like must be situated at a low level of the building, and have non-combustible supports.

2.6 Mezzanine floors: Concession

Intent

To provide concessions for small mezzanines.

The [Clause 2.6](#) concession does not apply to certain Class 9b buildings, as specified in [Clause 2.6\(a\)](#). The concession only applies to certain small mezzanines, as specified in [Clause 2.6\(b\)](#).

If it complies with the conditions specified in [Clause 2.6\(b\)](#), a mezzanine and its support may be constructed from materials that do not have an FRL and/or are combustible.

[Table 2.6](#) requires an increase in each FRL criterion of each wall or column that supports any other part of the building, and is within 6 metres of the mezzanine. There is no case in which a building element, with an increased fire rating, requires an FRL greater than 240 minutes.

Increasing the FRLs surrounding a mezzanine which is combustible, or which does not have an FRL, recognises the increased fire load that exists within both the mezzanine and the storey as a whole. This recognises the fire load limiting effect of the minimum area requirement in [Clause 2.6\(b\)\(i\)](#).

2.7 Enclosure of shafts

Intent

To minimise compromising the fire-resisting performance of a shaft.

Shaft enclosures required to be fire-resisting must be completely fire-separated from all other portions of the

Fire resistance

building by building elements that have the appropriate fire-resistance.

[Clause 2.7](#) complements other requirements for the walls of shafts by requiring that shafts be enclosed at the top and bottom by fire rated construction.

[Clause 2.7](#) grants exemptions for the top and bottom of shafts in cases where the likelihood of fire entering the shaft is unlikely. This occurs when the top of the shaft is the top of the building (see [Clause 2.7\(a\)](#)), or the bottom of the shaft is laid on the ground (see [Clause 2.7\(b\)](#)).

2.8 Carparks in Class 2 and 3 buildings

Intent

To allow the use of residential levels of fire protection to be used for carparks in certain Class 2 and Class 3 buildings.

[Part A6](#) classifies a storey used for carparking as Class 7. The fire risks of a single storey carpark in a low-rise Class 2 or Class 3 building are not as substantial as they are in other carparks attached to other classifications, so a concession is suitable. This concession is based upon the assumption that the carpark associated with the Class 2 or 3 building will be for the exclusive use of the building occupants and that the carpark would represent a low fire risk.

The sole purpose of this concession is to allow the carpark and/or ancillary use storey to be regarded as a Class 2 or Class 3 building, as applicable, for the purposes of determining the fire resistance requirements of [Specification C1.1](#).

This concession applies to buildings which are otherwise wholly Class 2, wholly Class 3 or a mix of Class 2 and 3 and:

- the storey to which the concession is to apply is used only for carparking, or an ancillary purpose such as storage of normal household items (see [Clause 2.8\(a\)\(i\)](#) and [\(b\)\(i\)](#));
- in the case of Class 2 buildings, contain no more than 4 storeys (see [Clause 2.8\(a\)\(ii\)](#)); and
- in the case of Class 3 buildings or buildings that are a mix of Class 2 and 3, contain no more than 3 storeys (see [Clause 2.8\(b\)\(ii\)](#)).

The reason for the concession applying to an additional storey in Class 2 buildings is that the residents of these buildings are long term and are usually aware of the building layout and exit routes. This concept is consistent with [D1.3](#).

The [Clause 2.8](#) concession does not apply if the building contains any other classification of building.

2.9 Residential care building: Concession

Intent

To allow concessions for the fire protection of certain building elements in residential care buildings when a suitable sprinkler system is used to achieve an adequate level of occupant safety.

“Residential care building” is defined in [Schedule 3](#).

This concession is a response to concerns expressed by aged care organisations and health authorities in regards to the impact of certain regulatory requirements on the design and operation of aged care hostels and nursing homes.

The requirements for fire separation of individual sole-occupancy units (including self-closing doors) in aged care hostels was considered to impose unwarranted development costs.

Fire compartmentation and the installation of door closers was considered to be impractical in the daily use of an aged care facility. Self-closing fire doors are too heavy and difficult to operate by frail, elderly people. In a number of cases this resulted in the doors being wedged open, thus negating the fire separation.

The limitation of the Class 1b concessions to buildings having an area of 300 m² or less and 12 occupants or less (see [A6.1](#)) meant that those concessions could not be used for many aged care hostels. The concessions in [Clause 2.9](#) are considered to be reasonable for the larger aged care hostels. In some States or Territories it is not acceptable for a Class 1b building to be used to house elderly people or other people who require special care.

The concession contained in [Clause 2.9\(a\)\(i\)](#) applies to the requirements for floors and loadbearing walls as set out in [Tables 3, 4 and 5 of Specification C1.1](#). The concession, allowing a reduction in FRLs, is limited to where the wall is an internal wall. An external wall is not subject to this concession.

The concession contained in [Clause 2.9\(a\)\(ii\)](#) for non-loadbearing internal walls, allows a reduction in FRLs

Fire resistance

subject to several conditions outlined in [Clause 2.9\(a\)\(ii\)](#). The conditions outlined in [Clause 2.9\(a\)\(ii\)](#) must be achieved for the concession to apply. These conditions require walls to be:

- lined with 13 mm standard grade plasterboard, or a non-combustible material equivalent to 13 mm standard grade plasterboard (see [Clause 2.9\(a\)\(ii\)\(A\)](#)); and
- extend to the underside of the floor above, a ceiling lined with standard grade plasterboard not less than 13 mm thick or equivalent fire protective material, or a non-combustible roof covering. The wall height requirement aims to create a smoke proof wall. This aim requires that joints and the like be sealed to prevent the spread of smoke through potential cracks and openings (see [Clause 2.9\(a\)\(ii\)\(B\)](#)).

[Clause 2.9\(a\)\(ii\)\(C\)](#) requires that any insulation in a cavity in a non-loadbearing internal wall must be non-combustible. This is to limit the spread of fire by way of the wall cavity.

The mandatory use of non-combustible materials prohibits the lining of non-loadbearing internal walls with timber panelling. This does not restrict the use of timber mouldings and the like.

In addition to the above concessions for load bearing and non-load bearing walls, doors in a Class 3 building must still comply with the requirements of [C3.11\(d\)\(ii\)](#), and walls must still comply with the requirements of [Part F5—Sound Transmission and Insulation](#).

Other provisions relating to residential care buildings are contained throughout the BCA. These include:

- [C3.11\(d\)\(ii\)](#), regarding construction bounding sole-occupancy units and public corridors;
- [Clause 6\(c\) of Specification E2.2a](#), regarding warning systems; and
- [Specification E1.5](#), regarding sprinkler systems.

3 Type A fire-resisting construction

3.1 Fire-resistance of building elements

Intent

To specify the fire-resistance level (FRL) and other requirements for building elements in Type A construction.

[Table 3](#) of [Specification C1.1](#) sets out the required FRLs of building elements in a building required to be of Type A construction. The required FRL depends on whether the element is loadbearing or non-loadbearing, if the element comprises or is incorporated in an external wall, and its distance from any fire-source feature.

When using [Table 3](#) of [Specification C1.1](#), it should be noted that [Clause 6 of Schedule 5](#) permits the deletion of the structural adequacy criteria of an FRL for non-loadbearing elements. The reason for this is that if such an element fails during a fire, there will be no flow-on collapse of other elements. See definition of 'loadbearing' in [Schedule 3](#) to assist in understanding this provision.

The surface of an occupiable outdoor area located on a roof should be treated as a floor for the purposes of [Specification C1.1](#).

[Clause 3.1\(a\)](#) requires building elements to achieve at least the FRLs set out in [Table 3](#).

[Clause 3.1\(a\)](#) only applies to the building elements listed in [Table 3](#), and any beams or columns incorporated in such building elements.

[Clause 3.1\(c\)](#) requires internal walls to extend to a barrier to stop or limit the spread of fire over the top of the wall. [Clause 3.1\(c\)](#) only applies to internal walls required to have an FRL with respect to integrity and insulation. This is consistent with the intent that the walls are only required to extend to the underside of a floor or roof, etc when the wall is required to perform a fire separating function.

[Clause 3.1\(d\)](#) requires loadbearing internal walls and loadbearing fire walls (in both cases, including those which are part of a loadbearing shaft) to be of concrete, masonry or constructed from fire-protected timber (however, fire-protected timber has certain limitations).

Internal columns can be exposed to a fire-source feature through a window in an external wall. [Clause 3.1\(f\)](#) requires such a column within 1.5 metres of a window to have the same FRL as an external column.

3.2 Concessions for floors

Intent

To allow certain floors to not have a fire-resistance level (FRL).

[Clause 3.2](#) grants floors a number of concessions from the FRL requirement. The reason for each of the

Fire resistance

concessions is listed below:

- there is no fire load below a floor laid directly on the ground, (see [Clause 3.2\(a\)](#));
- there is a low fire load if the space below a Class 2, 3, 5 or 9 building is not a storey or does not contain the listed elements, (see [Clause 3.2\(b\)](#));
- the space below a stage would generally have a low fire load because it cannot be used as a dressing room, storage area, or the like. A fire in the storey below would not affect the stage because it is over a floor with the required FRL. In addition, the stage would not have a room below which might have a high fire load, (see [Clause 3.2\(c\)](#));
- the floor is within a residential sole-occupancy unit. This is because resistance to the spread of fire between sole-occupancy units only is required. The levels connected are within the one sole-occupancy unit and the spread of fire from one sole-occupancy unit to another would not be affected by the construction of an internal floor without the required FRL, (see [Clause 3.2\(d\)](#)); and
- no fire separation is required for an open-access floor as a fire in the storey below could not affect the area because it is over a floor with the required FRL, (see [Clause 3.2\(e\)](#)).

3.3 Floor loading of Class 5 and 9b buildings: Concession

Intent

To allow a floor or roof in a Class 5 or Class 9b building to have a reduced fire-resistance level (FRL) if it is above a storey with a lower fire load.

Generally, Class 5 and Class 9b buildings have a comparatively low fire load which can be further reduced if the structural carrying capacity of the floor (“live load” or “imposed action”) is restricted because there will be a lower likelihood of the building containing a high level of stored combustible materials. AS 1170.1 and AS/NZS 1170.1 allows certain areas within office (Class 5) and assembly (Class 9b) buildings to have design floor loads of 3 kPa.

In essence, the lower the structural carrying capacity of the storey’s floor, the lower the fire load. This lower fire load in turn permits a reduced FRL for the floor or roof above such a storey.

The philosophy of fire protection in this provision is that the fire load of a storey controls the FRL of the floor or roof above it. This is because a fire on one storey will affect the level above to a greater degree than itself.

[Clause 3.3\(a\)](#) sets out the concession for a floor above, and [Clause 3.3\(b\)](#) sets out the concession for the roof above.

3.4 Roof superimposed on concrete slab: Concession

Intent

To allow a non-combustible non-fire-rated roof to be superimposed on a concrete slab roof.

[Clause 3.4](#) allows a concession for a roof of non-fire-resisting construction to be superimposed above a concrete slab roof. Such roofs are usually used for weather protection reasons.

[Clause 3.4\(a\)](#) states that the superimposed roof and any supporting members must be non-combustible.

[Clause 3.4\(b\)](#) states that the concrete slab roof must comply with [Table 3 of Specification C1.1](#).

If compliance is achieved with the conditions outlined in [Clause 3.4](#), a concession is reasonable because a fire is unlikely to break through the concrete roof slab.

3.5 Roof: Concession

Intent

To allow the roofs of certain buildings not to have a fire-resistance level (FRL).

The roofs of certain types of buildings can be required to have an FRL to limit the spread of fire from the roof to another building, or from another building to the roof. [Clause 3.5](#) grants a number of concessions by which certain roofs need not have an FRL, provided the roof covering is non-combustible.

In [Clause 3.5\(a\)](#), the BCA assumes that the specified sprinkler system will control any fire prior to it breaking through the roof.

In [Clause 3.5\(b\)](#), the BCA assumes buildings with a rise in storeys of 3 or less will comprise a comparatively low fire risk. Most buildings with a rise in storeys of 3 or less are permitted to be of Type B or Type C construction.

Fire resistance

In [Clause 3.5\(c\)](#), the BCA assumes that Class 2 and Class 3 buildings have a relatively low fire load compared to other classifications, and recognises that the potential size of a fire in Class 2 and Class 3 buildings is limited by the bounding construction of the sole-occupancy units. This concession does not apply where another classification forms part of the storey immediately below the roof (eg a restaurant, which is Class 6).

[Clause 3.5\(d\)](#) assumes that the incipient spread of fire resistant ceiling will stop or limit the spread of fire to the roof space or roof of the building for sufficient time for it to be brought under control.

3.6 Roof lights

Intent

To permit roof lights or the like in a roof that is required to either have an FRL or have a non-combustible covering.

The roofs of certain types of building can be required to have an FRL, or to be of non-combustible construction, to limit the spread of fire from the roof to another building. This is particularly the case with a high rise building. [Clause 3.6](#) specifies the requirements for such roof lights.

The requirements of [Clause 3.6](#) aim to minimise the risk that fire will spread by way of roof lights:

- from another building on an adjoining allotment;
- to an adjoining sole-occupancy unit; or
- to an adjoining fire compartment or fire-separated part of the building.

[Clause 3.6](#) facilitates this aim by minimising the:

- roof area which can be comprised of roof lights (see [Clause 3.6\(a\)](#));
- distance a roof light is from an allotment boundary (see [Clause 3.6\(b\)\(i\)](#));
- distance a roof light is from unprotected parts of the building which are higher than the roof (see [Clause 3.6\(b\)\(ii\)](#));
- distance a roof light is from roof lights or the like in adjoining sole-occupancy units, if the bounding walls are required to have an FRL (see [Clause 3.6\(b\)\(iii\)](#)); and
- distance a roof light is from any roof light or the like in adjoining fire-separated parts of the building (see [Clause 3.6\(b\)\(iv\)](#)).

In some cases, the BCA requires incipient spread of fire resistant ceilings to stop or limit the spread of a fire to the roof space.

[Clause 3.6\(c\)](#) provision requires that roof lights be installed in a manner which will maintain the requisite level of protection. This is an example of a “performance-type” provision within the Deemed-to-Satisfy Provisions. This is because a ceiling that has resistance to the incipient spread of fire is tested in the horizontal plane.

If roof lights are installed in a building, it may be necessary to install part of the ceiling in the vertical plane to connect the roof light with the ceiling below. Where this occurs, it may be necessary for a building proponent to provide evidence to an appropriate authority that the method proposed will meet the requirements of [Clause 3.6\(c\)](#).

However, in this case, if the material is installed on a vertical plane yet complies in all other respects with the tested prototype, it is unlikely that the ceiling’s fire performance will be affected.

3.7 Internal columns and walls: Concession

Intent

To allow lower fire-resistance levels (FRLs) for internal columns and walls which only support a non-fire-resisting roof.

In the storey immediately below the roof, under circumstances specified in [Clause 3.7](#), it is permissible to reduce or (in some cases) delete the FRL of:

- columns, other than those in that are:
 - within 1.5 metres of a window;
 - face that window; and
 - exposed to a fire-source feature through that window; and
- internal walls, other than fire walls and shaft walls.

[Clause 3.7](#) does not negate the need for internal columns to have the same FRL as an external column (set out in [Clause 3.1\(f\)](#)) where that internal column is:

Fire resistance

- within 1.5 metres of a window;
- faces that window; and
- exposed to a fire-source feature through that window.

3.8 Open spectator stands and indoor sports stadiums: Concession

Intent

To allow lower fire-resistance levels (FRLs) for building elements in open spectator stands and indoor sports stadiums.

The [Clause 3.8](#) concession is based on the BCA's overall assumption that there is generally a lower risk to the occupants of open spectator stands and indoor sports stadiums than in other buildings. The reasons for this concession are that:

- an open spectator stand generally has a low fire load, even though it may have a high population, particularly during an event, and is open at the front, facilitating the ventilation of smoke and heat; and
- in most indoor sports stadiums large areas are usually inaccessible to the public (being taken up as part of the sporting events) and the finishes are generally spartan.

See [Schedule 3](#) for definition of "open spectator stand".

3.9 Carparks

Intent

To allow lower fire-resistance levels (FRLs) for building elements in open-deck or sprinklered carparks.

[Clause 3.9](#) and [Table 3.9](#) are based on experimental research carried out at the BHP Research Laboratories. The research included full-scale fire tests on open-deck and enclosed carparks, and was supplemented by extensive overseas testing.

The research showed that the [Table 3.9](#) FRLs will not lead to an unsafe situation or structural failure of a building element in an open-deck carpark, or an enclosed carpark, which is sprinkler protected.

See [Schedule 3](#) for definition of "carpark". [Clause 3.9\(b\)](#) refines this definition when the expression is used in [Clause 3.9](#) and [Table 3.9](#).

Inclusions

[Clause 3.9](#) concessions include:

- a building which solely comprises a carpark (see [Clause 3.9\(a\)\(i\)](#));
- the carpark section of a building which, in part, has another use, and where the carpark and that use are fire-separated as required in [Clause 3.9\(a\)\(ii\)\(A\)-\(D\)](#) (regardless of the classification of that use, or whether that use is next to, above or below the carpark) (see [Clause 3.9\(a\)\(ii\)](#));
- any administrative area associated with the carpark, such as ticket selling and fee collection areas (see [Clause 3.9\(b\)\(i\)\(A\)](#)); and
- in a sprinkler protected carpark, small areas ancillary to a Class 2 or Class 3 building, such as part of the carpark used for normal 'household' storage (see [Clause 3.9\(b\)\(i\)\(B\)](#)).

Exclusions

[Clause 3.9](#) concessions exclude:

- any area of another Class (see [Clause 3.9\(b\)\(ii\)\(A\)](#));
- another Class 7 use (i.e. other than carparking), (see [Clause 3.9\(b\)\(ii\)\(A\)](#)); and
- an area "specifically intended" for the parking of vehicles such as trucks, buses, vans and the like (see [Clause 3.9\(b\)\(ii\)\(B\)](#)).

[Clause 3.9](#) and [Table 3.9](#), while using a refined definition of "carpark", also use the undefined expression "carparking". This word specifically refers to the parking of cars. This is also the intention of refining the definition of "carpark" as expressed by the use of the words "specifically intended" in [Clause 3.9\(b\)\(ii\)\(B\)](#).

The purpose of refining this definition, which is to limit the concessions in [Table 3.9](#) to areas used for the parking of lighter vehicles (that is, vehicles other than commercial trucks, vans, buses and the like), rather than simply limiting them to areas used for the parking of cars only.

Accordingly, it would seem contrary to the purpose of this clause to exclude from the refined definition and the

Fire resistance

word “carparking” such vehicles as motor bikes, van-like family vehicles, non-commercial panel vans, and smaller non-commercial utilities.

[Table 3.9](#) permits building elements to have either a specified FRL or a specified surface area to mass ratio. In relation to columns and beams, [Table 3.9](#) does not require them to have an FRL if they have the specified surface area to mass ratio. Some authorities refer to this ratio as the “heat sink effect”, in that the lower the exposed surface area to mass ratio, the lower will be the member temperature for a given fire.

The concession of [Table 3.9\(a\)](#) relating to columns, only applies to columns of any material which support a roof which is not used for carparking, and located 3 metres or more from a fire-source feature to which they are exposed.

The concession of [Table 3.9\(b\)](#) only applies to steel columns which support a roof which is used for carparking, and/or located less than 3 metres from a fire-source feature to which they are exposed. This concession is not applicable if the steel columns support any other part of the building which is not used as a carpark.

Columns of any material that do not qualify for [Table 3.9\(a\)](#) and [3.9\(b\)](#) concessions are subject to [Table 3.9\(c\)](#).

Example

The concession of (b) in the columns section of [Table 3.9](#) does not apply if the column supports a part of the building specifically intended for the parking of trucks, buses, vans, and the like.

In the section of [Table 3.9](#) relating to roofs, there is a concession for roofs that are not used for carparking.

A roof used for carparking must comply with any relevant requirements of [Table 3.9](#) (eg those relating to floor slabs).

3.10 Class 2 and 3 buildings: Concession**Intent**

To allow low-rise Class 2 and 3 buildings which are required to be of Type A construction to be constructed with timber framing and/or non-combustible materials.

[Clause 3.10](#) results from research undertaken by the National Association of Forest Industries and Forest and Wood Products Australia, which have been confirmed by overseas studies.

[Clause 3.10](#) provides a concession to [Clause 3.1\(d\)](#) and also to the combustibility requirements of [C1.9\(a\)](#) and [\(b\)](#) and [C2.6](#) to allow, subject to specified conditions, the use in certain Class 2 and 3 buildings, timber framing instead of an alternative structural support system using non-combustible materials, concrete, or masonry.

[Clause 3.10\(a\)\(i\)](#) allows the use of timber framing.

[Clause 3.10\(a\)\(ii\)](#) allows the use of non-combustible materials (such as steel) for firewalls and internal walls required to be fire resisting, instead of concrete or masonry as required by [Clause 3.1\(d\)](#).

[Clause 3.10\(a\)\(iii\)](#) allows a combination of timber framing and non-combustible materials.

The [Clause 3.10\(a\)](#) concession to use timber framing and/or non-combustible materials is conditional on:

- a firewall or internal wall required to be fire-resisting being extended to the underside of the non-combustible roof covering. The wall height requirement, together with the smoke sealing requirement of [Clause 3.10\(c\)\(ii\)\(D\)](#), aims to create a smoke proof wall, hence the requirement for sealing any cracks and openings against the spread of smoke. It should be noted that these walls may need to meet other requirements of Type A construction such as those of [Clause 3.1\(c\)](#);
- only non-combustible insulation being used in a wall cavity. This aims to limit the spread of fire by way of the cavity; and
- an automatic smoke alarm system being installed in the building to give early warning of a fire.

[Clause 3.10\(b\)](#) allows the top three storeys of a four storey Class 2 or 3 building to be constructed with timber framing and/or non-combustible materials if they are located above a single storey used for vehicle parking (note that the limitation in [Clause 3.9](#) by use of the word “carparking” does not apply here) and ancillary purposes. These ancillary purposes include such items as individual storerooms, laundries, and the like.

To achieve this concession, the lowest carparking storey (including the floor/ceiling between the carpark and the storey above) must be constructed of concrete or masonry, and have the FRLs specified in [Table 3](#), or reduced by [Clause 3.10\(c\)](#). The floor between the carpark and the storey above must not contain penetrations or openings that would reduce the fire-resisting performance of the floor. The exception to this is a door which is permitted to be a –/60/30 self-closing fire door.

Under the [Clause 2.8](#) concession, the vehicle parking storey can be classified as a Class 2 or 3 building for the

Fire resistance

purpose of determining the relevant fire-resisting requirements of [Specification C1.1](#).

The basis of the [Clause 3.10\(b\)](#) concession is that the concrete or masonry floor of the first storey above the lowest carparking storey will provide adequate fire separation. [Clause 3.10](#) does not require smoke detectors or sprinklers in the lowest carparking storey because a fire occurring in it should not pose an unacceptable risk to occupants evacuating from the upper three storeys.

Compliance must still be achieved with the other requirements of [Specification C1.1](#) and other parts of the BCA, including the relevant FRLs listed in [Table 3 of Specification C1.1](#), and any relevant requirements of [Clause E1.5](#).

Subject to the conditions listed, including the installation of a sprinkler system, [Clause 3.10\(c\)](#) allows:

- a reduction of the FRL of loadbearing walls (see [Clause 3.10\(c\)\(i\)](#)); and
- the deletion of the FRL for non-loadbearing internal walls (see [Clause 3.10\(c\)\(ii\)](#)).

Reference to [Clause 2 of Specification E1.5](#) indicates one of the technical standards that the sprinkler system may comply with is AS 2118.4—Automatic fire sprinkler systems—Residential. This Standard has been specifically developed to provide a degree of life safety and property protection for occupants of low-rise Class 2 and 3 buildings. If the storey used as carpark requires sprinklers by [Clause E1.5](#), then the carpark is considered a Class 7 building for the purposes of applying [Specification E1.5](#) (see [E1.5](#)).

[Clause 3.10\(c\)\(ii\)](#) allows non-loadbearing internal walls to have no FRL. The concession is subject to the requirement that the internal walls be lined on each side with 13 mm standard grade plasterboard or non-combustible materials with a similar fire-resisting performance. This means that all doors from sole-occupancy units to corridors, when applying these concessions, must be smoke proof doors. Self-closing solid core doors satisfy this requirement (see [Specification C3.4](#)).

The [Clause 3.10\(c\)\(ii\)\(B\)](#) provision regarding the height of a non-loadbearing wall, to which this concession is applied, aims to create a smoke proof wall, hence the requirement for sealing any cracks and openings against the spread of smoke.

The [Clause 3.10\(c\)\(ii\)\(C\)](#) requirement that only non-combustible insulation can be used in a cavity in a non-loadbearing wall, to which this concession is applied, aims to limit the spread of fire by way of the cavity.

4 Type B fire-resisting construction

4.1 Fire-resistance of building elements

Intent

To specify the fire-resistance level (FRL) and other requirements of building elements in Type B construction.

[Table 4 of Specification C1.1](#) sets out the required FRLs of building elements in a building required to be of Type B construction. The required FRL depends on whether the element is loadbearing or non-loadbearing, if the element comprises or is incorporated in an external wall, and its distance from any fire-source feature to which it is exposed.

Although a roof is an external building element that can be exposed to a fire-source feature, it is not required to comply with the FRLs specified under the heading of external wall in [Table 4](#). The FRLs required for a roof are contained under the heading of roofs near the bottom of the Table.

When using [Table 4 of Specification C1.1](#), it should be noted that [Clause 6 of Schedule 5](#) permits the deletion of the structural adequacy criterion of an FRL for non-loadbearing elements. The reason for this is that if such an element fails during a fire, there will be no flow-on collapse of other elements. See [Schedule 3](#) for the definition of “loadbearing”.

Generally speaking, Type B construction differs from Type A construction by allowing lower FRLs for external walls, generally not requiring roofs and floors to have an FRL, and not requiring FRLs for ventilation, garbage, and similar shafts.

These differences are based on the lower rise in storeys allowed by [Table C1.1](#); and the smaller size of Type B construction buildings allowed by [Table C2.2](#).

The BCA requires the floors of buildings required to be of Type B construction to have an FRL in Class 2 and Class 3 buildings, if the floor supports different sole-occupancy units (see [Clause 4.1\(i\)](#)), in Class 9a buildings as part of the fire compartments required by [C2.5\(a\)\(iv\)](#) and in Class 9c buildings as part of the fire compartments required by [C2.5\(b\)\(ii\)](#) (see [Clause 4.1\(j\)](#)).

[Clause 4.1\(a\)](#) requires building elements to achieve at least the FRLs set out for them in [Table 4](#). [Clause 4.1\(a\)](#) only applies to the building elements listed in [Table 4](#), and any beams or columns incorporated in such building

Fire resistance

elements.

[Clause 4.1\(c\)](#) requires stair shafts which support floors or structural parts of floors to either have a specified FRL, or be constructed at the junction of the shaft and floor (or part of floor), so that if the floor falls or collapses (fully or partly) during a fire, the shaft will not be damaged.

[Clause 4.1\(d\)](#) requires internal walls to extend to a barrier to stop or limit the spread of fire over the top of the wall. Such a requirement is not considered necessary when a sole-occupancy unit occupies the whole of the top storey. This concession applies to buildings of Type B construction. [Clause 4.1\(d\)](#) only applies to internal walls required to have an FRL with respect to integrity and insulation. This is consistent with the intent that the walls are only required to extend to the underside of a floor or roof, etc when the wall is required to perform a fire separating function.

[Clause 4.1\(e\)](#) requires loadbearing internal walls and loadbearing fire walls (in both cases, including those which are part of a loadbearing shaft) to be of concrete, masonry or constructed from fire-protected timber (however, fire-protected timber has certain limitations).

Under [Clause 4.1\(g\)](#), internal columns and internal walls need not comply with [Table 4](#) if they are:

- in a Class 5–9 building;
- in the storey immediately below the roof; and
- not fire walls or shaft walls.

[Clause 4.1\(i\)](#) does not apply if the storeys being separated are within a sole-occupancy unit of a Class 2 or 3 building, because it is likely that the two levels are connected by a non-fire-isolated stairway.

The primary reason for the [Clause 4.1\(i\)](#) fire separation requirement is that in a building fire, the highest degree of risk is attached to such people as the very young, people with disabilities, the elderly, and those who are asleep.

[Table 5](#) requires internal walls bounding a stair required to be rated to have an FRL of 60/60/60. The reason for this is because although [Table C1.1](#) only allows buildings of Type C construction to have a maximum rise in storeys of 2, such buildings may include a basement which is not included in the calculation of rise in storeys. If a stairway in the building connects say a basement with two other storeys, in accordance with [D1.3](#), a fire-isolated exit would be required. [Table 5](#) then sets out the required FRL for the walls of the stairway.

Examples

Buildings, which must comply with [Clause 4.1\(i\)](#), include:

- A Class 2 building (which includes flats, apartments, etc).
- A Class 3 building (which includes hotels, motels, etc).
- The residential part of a school.
- Accommodation for the aged, children or people with disabilities.
- A residential aged care building.
- A Class 9a building (which includes hospitals, etc).
- A Class 9b building, such as schools, theatres, and the like.

4.2 Carparks

Intent

To allow lower fire-resistance levels (FRLs) for building elements in open-deck or sprinklered carparks.

[Clause 4.2](#) and [Table 4.2](#) are based on experimental research carried out at the BHP Research Laboratories. The research included full scale fire tests on both open-deck and enclosed carparks, and was supplemented by extensive overseas testing.

The research carried out on this matter showed that the [Table 4.2](#) FRLs will not lead to an unsafe situation or structural failure of a building element in an open-deck carpark, or an enclosed carpark which is sprinkler protected.

See [Schedule 3](#) for definition of “carpark”. [Clause 4.2\(b\)](#) refines this definition when the expression is used in [Clause 4.2](#) and [Table 4.2](#).

Inclusions and exclusions

[Clause 4.2](#) concessions include:

- a building which solely comprises a carpark;

Fire resistance

- the carpark section of a building which elsewhere has another use;
- any administrative area associated with the carpark, such as ticket selling and fee collection areas; and
- in a sprinkler protected carpark, small areas ancillary to a Class 2 or Class 3 building, such as part of the carpark used for normal “household” storage.

Clause 4.2 concessions exclude:

- any area of another Class;
- another Class 7 use (i.e. other than carparking); and
- an area “specifically intended” for the parking of vehicles such as trucks, buses, vans and the like.

Clause 4.2 and Table 4.2, while using a refined definition of “carpark”, also use the undefined expression “carparking”. This word specifically refers to the parking of cars. This is also the intention of refining the definition of “carpark” as expressed by the use of the words “specifically intended” in Clause 4.2(b)(ii)(B).

However, in applying these provisions, it is important to consider the purpose of refining this definition, which is to limit the concessions in Table 4.2 to areas used for the parking of lighter vehicles (that is, vehicles other than commercial trucks, vans, buses and the like)—rather than simply limiting them to areas used for the parking of cars only.

Accordingly, it would seem contrary to the purpose of this clause to exclude from the refined definition and the word “carparking” such vehicles as motor bikes, van-like family vehicles, non-commercial panel vans, and smaller non-commercial utilities.

Regarding certain types of column and beam, Table 4.2 permits them to have either a specified FRL or a specified surface area to mass ratio. In other words, in relation to these columns and beams, Table 4.2 does not require them to have an FRL if they have the specified surface area to mass ratio. Some authorities refer to this ratio as the “heat sink effect”, in that the lower the exposed surface area to mass ratio, the lower will be the member temperature for a given fire.

The concession for columns in Table 4.2(a) applies to columns of any material which support a roof which is not used for carparking, and located 3 metres or more from a fire-source feature to which they are exposed.

The concession in Table 4.2(b) only applies to steel columns that support a roof which is used for carparking, and/or located less than 3 metres from a fire-source feature to which they are exposed. This concession is also applicable where steel columns support any other part of the building that is not used as a carpark.

Columns of any material which do not qualify for the Table 4.2(a) and (b) concessions are subject to Table 4.2(c).

For the purposes of this clause, the usual definition of “carpark” is specifically amended (see Clause 4.2(b)).

Example

The concession of (b) in the columns section of Table 4.2 does not apply if the column supports a part of the building specifically intended for the parking of trucks, buses, vans, and the like.

Table 3.9 provisions restricting the roof concession to those roofs that are not used for carparking does not apply to Table 4.2.

The differences between Table 4.2 and Table 3.9 are based on the lower rise in storeys allowed for Type B construction buildings by Table C1.1.

4.3 Class 2 and 3 buildings: Concession

Intent

To allow low-rise Class 2 and 3 buildings which are required to be of Type B construction to be constructed with timber framing and/or non-combustible materials.

Clause 4.3 results from research undertaken by the National Association of Forest Industries and Forest and Wood Products Australia, which have been confirmed by overseas studies.

The effect of Clause 4.3 is to provide a concession to Clause 4.1 to allow, subject to specified conditions, the use in certain Class 2 and 3 buildings of timber framing instead of an alternative structural support system using non-combustible materials, or concrete, or masonry.

Clause 4.3(a)(i) allows the use of timber framing.

Clause 4.3(a)(ii) allows the use of non-combustible materials (such as steel) for fire walls and internal walls required to be fire-resisting, instead of concrete or masonry as required by Clause 4.1(e).

Fire resistance

Clause 4.3(a)(iii) allows a combination of timber framing and non-combustible materials.

Table C1.1 limits Class 2 and 3 buildings of Type B construction to a rise in storeys of two. For this reason Clause 4.3 only applies to two storey Class 2 and 3 buildings, and no concession is allowed for a two storey timber framed building above a concrete or masonry lower storey, as is allowed in the case of Type A construction buildings by Clause 3.10.

The Clause 4.3(a) concession to use timber framing and/or non-combustible materials is conditional on:

- a fire wall or internal wall required to be fire-resisting being extended to the underside of the non-combustible roof covering. The wall height requirement, together with the smoke sealing requirement of Clause 4.3(c)(ii)(D), aims to create a smoke proof wall, hence the requirement for sealing any cracks and openings against the spread of smoke;
- only non-combustible insulation being used in a wall cavity. This aims to limit the spread of fire by way of the cavity; and
- an automatic smoke alarm system being installed in the building to give early warning of a fire.

Clause 4.3(b) allows a 2 storey Class 2 or 3 building to be constructed with timber framing and/or non-combustible materials if the lowest storey is used for vehicle parking (note that the limitation in Clause 4.2 by use of the word “carparking” does not apply here) and ancillary purposes. These ancillary purposes include such items as individual storerooms, laundries, and the like.

To achieve this concession, the lowest carparking storey (including the floor/ceiling between the carpark and the storey above) must be constructed of concrete or masonry, and have the FRLs specified in Table 4. The floor between the carpark and the storey above must not contain penetrations or openings that would reduce the fire-resisting performance of the floor. The exception to this is a doorway which is permitted to be protected by a –/60/30 self-closing fire door.

Under the Clause 2.8 concession, the carparking storey can be classified as a Class 2 or 3 building for the purpose of determining the relevant fire-resisting requirements of Specification C1.1.

Subject to the conditions listed, including the installation of a sprinkler system, Clause 4.3(c) allows a reduction of the FRL of loadbearing elements, and the deletion of the FRL for non-loadbearing elements.

Reference to Clause 2 of Specification E1.5 indicates one of the technical standards that the sprinkler system may comply with is AS 2118.4—Automatic fire sprinkler systems—Residential. This Standard has been specifically developed to provide a degree of life safety and property protection for occupants of low-rise Class 2 or 3 buildings (see E1.5).

Clause 4.3(c)(ii)(A) allows non-loadbearing internal walls to not have an FRL. The concession is subject to the requirement that the internal walls be lined on each side with 13 mm standard grade plasterboard or non-combustible materials.

The Clause 4.3(c)(ii)(B) provision regarding the height of a non-loadbearing wall to which this concession is applied aims to create a smoke proof wall, hence the Clause 4.3(c)(ii)(D) requirement for sealing any cracks and openings against the spread of smoke.

The Clause 4.3(c)(ii)(C) requirement that only non-combustible insulation can be used in a cavity in a non-loadbearing wall to which this concession is applied aims to limit the spread of fire by way of the cavity.

There is no specific concession to permit the use of solid core doors in Type B construction buildings, unlike that in Clause 3.10(c)(ii)(E), this is because they are already permitted in Type B construction (see C3.11).

The result of Clause 4.3 is that a designer proposing to use the BCA Deemed-to-Satisfy Provisions to design a two storey Class 2 or 3 building of Type B construction has three basic options:

- design in accordance with other provisions applicable to buildings of Type B construction which, under C1.9(a) and (b) and Clause 4.1(e) would exclude the use of timber external walls, common walls, loadbearing internal walls, fire walls and non-loadbearing internal walls required to be fire-resisting;
- use timber and/or non-combustible materials in accordance with Clause 4.3; or
- comply with C1.5 and design for Type C construction, which places no limitations on the use of timber.

5 Type C fire-resisting construction

5.1 Fire-resistance of building elements

Intent

To specify the fire-resistance level (FRL) and other requirements of building elements in a building required to be of

Fire resistance

Type C construction.

[Table 5](#) of [Specification C1.1](#) set out the required FRLs of building elements in a building required to be of Type C construction. If the element comprises or is incorporated in an external wall, the required FRL depends on distance from any fire-source feature to which it is exposed.

Although a roof is an external building element that can be exposed to a fire-source feature, it is not required to comply with the FRLs specified under the heading of external wall in [Table 5](#). The FRLs required for a roof are contained under the heading of roofs near the bottom of the table.

When using [Table 5](#) of [Specification C1.1](#), it should be noted that [Clause 6 of Schedule 5](#) permits the deletion of the structural adequacy criteria of an FRL for non-loadbearing elements. The reason for this is that if such an element fails during a fire, there will be no flow-on collapse of other elements. See [Schedule 3](#) for definition of “loadbearing”.

Generally speaking, Type C construction differs from Type B construction by allowing lower FRLs for external walls which are located more than 1.5 metres from a fire-source feature, and only requiring a maximum FRL of 90 minutes for any criterion. [Table C2.2](#) bases these differences on the lower rise in storeys allowed by [Table C1.1](#), and the smaller size of Type C buildings allowed.

No building element in a building required to be of Type C construction is required to be non-combustible, or of concrete or masonry.

[Clause 5.1\(a\)](#) requires building elements to achieve at least the FRLs set out for them in [Table 5](#). [Clause 5.1\(a\)](#) only applies to the building elements listed in [Table 5](#), and any beams or columns incorporated in such building elements.

Where [Table 5](#) requires an external wall to have an FRL, [Clause 5.1\(b\)](#) requires that the wall only need be tested from outside to meet the FRL criteria. This allows the use of brick veneer construction where the brick has the required FRL.

Where a fire wall and the specified internal walls are of lightweight construction they must comply with [Specification C1.8](#).

[Clause 5.1\(d\)](#) requires internal walls to extend to a barrier to stop or limit the spread of fire over the top of the wall.

The concession contained in [Clause 4.1\(d\)](#) for Type B construction with respect to the height of the wall when a sole-occupancy unit occupies the whole of the top storey, does not apply to Type C construction.

To protect building occupants of Class 2, 3 and 9 buildings from fire spread between storeys, [Clause 5.1\(e\)](#) establishes the minimum fire separation between storeys in such buildings. This requirement takes into account the special risks that can exist in such buildings.

This requirement also relates to the fire separation of Class 2, 3 and 9 buildings from a carpark or storage area.

[Clause 5.1\(e\)](#) does not apply if the storeys being separated are within a sole-occupancy unit of a Class 2 or Class 3 building, because it is likely that the two levels are connected by a non-fire-isolated stairway and would therefore not be required to be fire separated.

The primary reason for the [Clause 5.1\(e\)](#) and [\(f\)](#) fire separation requirement is that in a building fire, the highest degree of risk is attached to such people as the very young, people with disabilities, the elderly, and those who are asleep.

Examples

Buildings that must comply with [Clause 5.1\(e\)](#) include:

- A Class 2 building (which includes flats, apartments, etc).
- A Class 3 building (which includes hotels, motels, etc).
- The residential part of a school.
- Accommodation for the aged, children or people with disabilities.
- A residential aged care building.
- A Class 9a building (which includes hospitals, etc).
- A Class 9b building, such as schools, theatres, and the like.

5.2 Carparks

Intent

To allow lower fire-resistance levels (FRLs) for building elements in open-deck or sprinklered carparks.

[Clause 5.2](#) and [Table 5.2](#) are based on experimental research carried out at the BHP Research Laboratories. The research included full scale fire tests on both open-deck and enclosed carparks, and was supplemented by extensive overseas testing.

The research carried out on this matter showed that the [Table 5.2](#) FRLs will not lead to an unsafe situation or structural failure of a building element in an open-deck carpark, or an enclosed carpark which is sprinkler protected.

See [Schedule 3](#) for definition of “carpark”. [Clause 5.2\(b\)](#) refines this definition when the expression is used in [Clause 5.2](#) and [Table 5.2](#).

Inclusions and exclusions

The [Clause 5.2](#) concessions include:

- a building which solely comprises a carpark;
- the carpark section of a building which elsewhere has another use;
- any administrative area associated with the carpark, such as ticket selling and fee collection areas; and
- in a sprinkler protected carpark, small areas ancillary to a Class 2 or Class 3 building, such as part of the carpark used for normal ‘household’ storage.

The [Clause 5.2](#) concessions exclude:

- any area of another Class;
- another Class 7 use (i.e. other than carparking); and
- an area “specifically intended” for the parking of vehicles such as trucks, buses, vans and the like.

[Clause 5.2](#) and [Table 5.2](#), while using the refined definition of “carpark”, also use the undefined expression “carparking”. This word specifically refers to the parking of cars. This is also the intention of refining the definition of “carpark” as expressed by the use of the words “specifically intended” in [Clause 5.2\(b\)\(ii\)\(B\)](#).

However, in applying these provisions, it is important to consider the purpose of refining this definition, which is to limit the concessions in [Table 5.2](#) to areas used for the parking of lighter vehicles (that is, vehicles other than commercial trucks, vans, buses and the like), rather than simply limiting them to areas used for the parking of cars only.

Accordingly, it would seem contrary to the purpose of this clause to exclude, from the refined definition and the word “carparking”, such vehicles as motor bikes, van-like family vehicles, non-commercial panel vans, and smaller non-commercial utilities.

Regarding certain types of columns and beams, [Table 5.2](#) permits them to have either a specified FRL or a specified surface area to mass ratio. In other words, in relation to these columns and beams, [Table 5.2](#) does not require them to have an FRL if they have the specified surface area to mass ratio. Some authorities refer to this ratio as the “heat sink effect”, in that the lower the exposed surface area to mass ratio, the lower will be the member temperature for a given fire.

In the section of [Table 5.2](#) relating to columns:

- the concession of (a) applies only to steel columns that are located less than 1.5 metres from any fire-source feature; and
- the concession of (b) applies only to columns of any material which are located less than 1.5 metres from any fire-source feature.

Columns of any material that do not qualify for the (a) and (b) concessions are subject to (c).

Roofs that do not qualify for the roof concession in [Table 5.2](#) must comply with the requirements of [Specification C1.1](#) for roofs of other buildings.

[Table 3.9](#) provisions restricting the roof concession to those roofs that are not used for carparking does not apply to [Table 5.2](#).

The differences between [Table 5.2](#) and [Table 4.2](#) are based on the lower rise in storeys allowed for Type C buildings by [Table C1.1](#).

Specification C1.8**Structural tests for lightweight construction****Deemed-to-Satisfy Provisions**

This Guide does not address, in detail, every provision in this Specification.

Lightweight construction is more susceptible to damage than other forms of fire protection. It therefore needs protection to preserve its integrity in a fire.

[Specification C1.8](#) describes a number of tests on walls of lightweight construction which can be used to demonstrate their acceptance as a fire protection system under the Deemed-to-Satisfy Provisions.

Specification C1.10**Fire hazard properties****Deemed-to-Satisfy Provisions****1 Scope****Intent**

To set out the scope of [Specification C1.10](#).

It should be noted that [C1.10](#) requires the fire hazard properties of linings, materials and assemblies used in the construction of a building to comply with [Specification C1.10](#). [Specification C1.10](#) sets out the details of these requirements.

2 Application**Intent**

To set out clauses in the Specification, that the linings, materials and assemblies must comply with.

[Table 1](#) sets out which Clauses of [Specification C1.10](#) linings, materials and assemblies must comply with.

3 Floor linings and floor coverings**Intent**

To prescribe the fire hazard properties of floor linings and floor coverings.

[Clause 3\(a\)](#) states that a floor lining or covering must have a critical radiant flux not less than that in [Table 2](#). A material's critical radiant flux is determined by testing the material in accordance with AS ISO 9239.1. This test is the floor radiant panel test. The higher a material's critical radiant flux is, the better the material performs.

The different requirements for materials are based on the building classification, the location of the material in the building and whether the building contains a sprinkler system. The requirements are higher for aged care buildings and health care buildings due to the limited mobility of occupants in those buildings. The requirements are based on research which indicated that the required egress time in these buildings was greater and therefore proposed levels of control needed to be greater.

[Clause 3\(b\)](#) contains requirements dealing with a material's smoke development rate. A material's smoke development rate is determined by testing the material in accordance with AS ISO 9239.1. This test is the floor radiant panel test. The requirement is only applicable where floor materials and coverings are installed in buildings that do not have a sprinkler system complying with [Specification E1.5](#). [Clause 3\(b\)](#) limits the smoke development rate to not more than 750 percent-minutes.

[Table 2](#) does not contain any requirements for Class 9c buildings that do not contain a sprinkler system. The reason for this is because, pursuant to [E1.5](#), all Class 9c buildings must have a sprinkler system installed throughout the building.

4 Wall and ceiling linings**Intent**

To prescribe the fire hazard properties of wall and ceiling linings.

[Clause 4](#) specifies that a material used as a wall or ceiling lining must be a Group 1, Group 2 or Group 3 material and used in accordance with [Table 3](#). A material's group number is determined by testing the material in accordance with AS 5637.1.

For the purpose of the BCA, a Group 1 material indicates the best performing material and a Group 4 material is the worst performing material.

The allowable material group number differences are based on the building classification and the location of the material in the building. It is also dependent on whether the building contains a sprinkler system (other than a FPAA101D or FPAA101H system) in accordance with [Specification E1.5](#), and whether the material is used as a wall

Fire resistance

lining or a ceiling lining.

The locations within the building referred to in [Table 3](#) are fire-isolated exits, fire control rooms, public corridors, specific areas and other areas. The definition of specific areas differs according to the use of the building. The specific areas are as follows:

- for Class 2 and 3 buildings, a sole-occupancy unit;
- for Class 5 buildings, open plan offices with a minimum floor dimension/floor to ceiling height ratio >5;
- for Class 6 buildings, shops or other buildings with a minimum floor dimension/floor to ceiling height ratio >5;
- for Class 9a health care buildings, patient care areas;
- for Class 9b theatres and halls, etc, an auditorium;
- for Class 9b schools, a classroom; and
- for Class 9c buildings, resident use areas.

For Class 5 and 6 buildings, the minimum floor dimension and the floor to ceiling height need to be considered when determining “specific areas”. An area is a specific area if the minimum floor dimension/floor to ceiling height ratio is more than 5.

Example

Consider the case of a Class 5 building having a 15 m by 20 m open plan office with a ceiling height of 2.5 m. The building also contains an enclosed office having a floor plan of 3 m by 4 m.

For the open plan office area, as the minimum floor dimension (15 m) divided by the ceiling height (2.5 m) is 6, i.e. more than 5, it would be deemed a “specific area” and therefore wall and ceiling linings in the area would need to comply with the requirements for Class 5 “specific areas”.

For the enclosed office, as the minimum floor dimension (3 m) divided by the ceiling height (2.5 m) is 1.2, i.e. less than 5, it would not be deemed to be a “specific area” and therefore wall and ceiling linings in the enclosed office would need to comply with the requirements for Class 5 “other areas”.

“Other areas” are areas which are not either a fire-isolated exit, a public corridor or a “specific area”.

The requirements differ between the building classifications. These requirements are based on research which indicated that the required egress time differed between the building’s classifications and therefore proposed levels of control needed to be greater.

[Clause 4\(a\)](#) contains requirements dealing with a material’s smoke development rate. The requirements only apply where the wall and/or ceiling lining material is installed in a building that does not have a sprinkler system complying with [Specification E1.5](#) (other than a FPAA101D or FPAA101H system).

5 Air-handling ductwork**Intent**

To specify requirements for air-handling ductwork.

Air-handling ductwork has the potential to cause the rapid spread of fire throughout a building. It is important that the materials used in its construction are appropriate to avoid this potentially dangerous situation. The particular requirements are covered by AS 4254.

6 Lift cars**Intent**

To specify requirements for lift cars.

Lift cars are small, enclosed spaces, with minimal ventilation and no active fire suppression equipment. They also have no immediate means of egress. The materials used in their construction must be appropriate to avoid a potentially dangerous situation. The particular requirements are outlined in AS 1735.2. The appropriate Occupational Health and Safety Authorities also enforce these requirements.

Additionally, floor linings and floor coverings must have a critical radiant flux of not less than 2.2, and the wall linings and ceiling linings must be either a Group 1 material or a Group 2 material, which are similar to those required in public corridors.

7 Other materials

Intent

To specify requirements for other locations and materials.

[Clause 7](#) sets out requirements for materials and assemblies not included elsewhere in [Specification C1.10](#). The detail is located in [Table 4](#). It is important to read the notes to this table because they contain specific requirements.

Fire-isolated exits and fire control rooms

Because fire-isolated exits are considered a safe place for people seeking egress during a fire, it is acknowledged that they should be as safe as possible.

Similarly, fire control rooms are part of a building set aside for the fire brigade to co-ordinate its search, rescue and firefighting operations during a fire. Since fire control rooms are used by the fire brigade during a fire, they should also be as safe as possible.

The basic aim of [Table 4](#) is to minimise the risk of a fire in a fire-isolated exit and a fire control room.

It could be claimed that fire is unlikely to enter either of these spaces because of their construction and protection, and therefore there is no need for control of the finishes within them. However, compromising the integrity of these spaces is not at all unusual. For example, by—

- removal, alteration or deterioration of fire doors; or
- wedging open fire doors in fire-isolated stairways.

The prescribed Spread-of-Flame Index and Smoke-Developed Index measures aim to limit finishes to those that are no more hazardous than a conventional paint finish on a non-combustible surface.

The requirements for sarking-type materials in a fire-isolated exit or fire control room are contained under the heading of sarking-type material.

Class 9b theatres, public halls and the like

To minimise the spread of fire and smoke in a Class 9b building used as a theatre, public hall or the like, [Table 4](#) contains specific requirements for—

- fixed seating used by the audience; and
- proscenium curtains.

Escalators, non-required non fire-isolated stairways and ramps, etc.

[Table 4](#) contains requirements for materials not listed elsewhere in [Specification C1.10](#), used in stairways, ramps and escalators not required by the BCA, and which are non fire-isolated. These requirements aim to prevent the spread of fire through an unrestricted number of floors through unprotected openings for stairways, ramps and escalators. Further requirements for escalators, non-required non fire-isolated stairways and ramps can be found in [D1.12](#) and [Specification D1.12](#).

Sarking-type material

The requirements in [Table 4](#) for a sarking-type material, in areas other than fire-isolated exits and fire control rooms, to have a Flammability Index of not more than 5 is to minimise the risk of sarking facilitating the spread of fire.

Example

Before the flammability of sarking was regulated, there was a supermarket fire with the following characteristics:

- The building was single storey, and similar to the current Type C construction.
- The fire was caused by faulty electrical wiring, started in a small switch and staff room, and was noticed by an employee in its initial stages.

Under normal circumstances this fire would be easily extinguished, but it penetrated the ceiling through a small hole for electrical wiring and ignited the sarking immediately above.

The sarking aided the spread of fire through the roof space.

As a result, there was severe damage to the roof structure, including the metal roof cladding, steel purlins, bracing and trusses, timber battens and plaster ceilings, leading to burning debris falling down onto the floor.

As explained above, fire-isolated exits are considered a safe place for people seeking egress during a fire. Likewise, fire control rooms are spaces used by the fire brigade during a fire. Accordingly, both spaces should be as safe as possible and the required Flammability Index is more restrictive.

Other materials

Fire resistance

The other materials referred to in [Table 4](#) are materials not referred to in other parts of [Specification C1.10](#) and elsewhere in [Table 4](#). Such materials include, but are not limited to the following:

- Window frames other than timber window frames (timber window frames are exempt from the requirements of [Specification C1.10](#), see [C1.10\(c\)](#)).
- Attachments to walls, floors and ceilings.

Specification C1.11

Performance of external walls in fire

Deemed-to-Satisfy Provisions

1 Scope

Intent

To clarify that [Specification C1.11](#) aims to minimise the risk, in a fire, of external walls collapsing outwards as complete panels and panels separating from supporting members.

[Specification C1.11](#) contains detailed Deemed-to-Satisfy Provisions that could form part of a solution to achieve CP5. These provisions include solutions to avoid the potential collapse outwards, as whole panels, of concrete external walls in a building with a rise in storeys of not more than 2, and minimum design loads which panel connections must resist during a fire.

2 Application

Intent

To clarify that [Specification C1.11](#) applies only to buildings with a rise in storeys of 2 or less, where those buildings have concrete external walls that could collapse as complete panels.

[Specification C1.11](#) applies only to buildings with a rise in storeys of 2 or less, where the external walls are constructed using tilt-up and precast concrete panels.

[Figure Spec C1.11\(1\)](#) and [Spec C1.11\(2\)](#) illustrate some of the types of construction covered by [Specification C1.11](#).

Figure Spec C1.11(1) Typical non-loadbearing panels required to comply with Specification C1.11 (Panels may be full bay, multiple vertically or horizontally spanning)

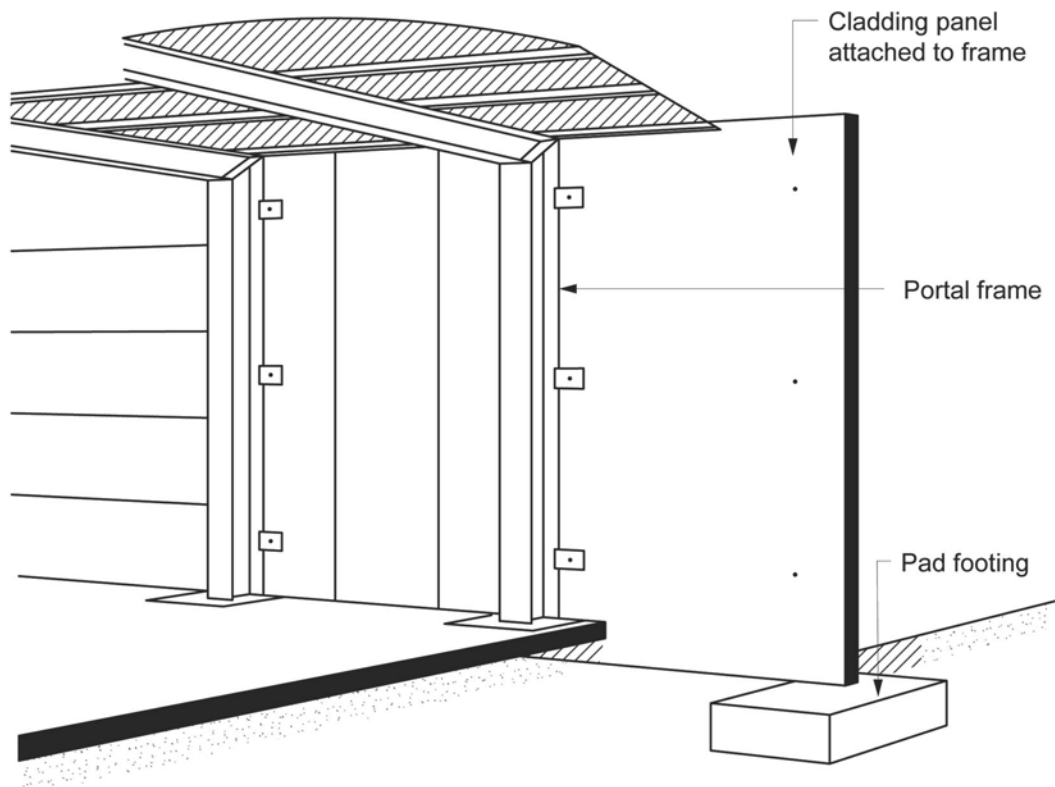
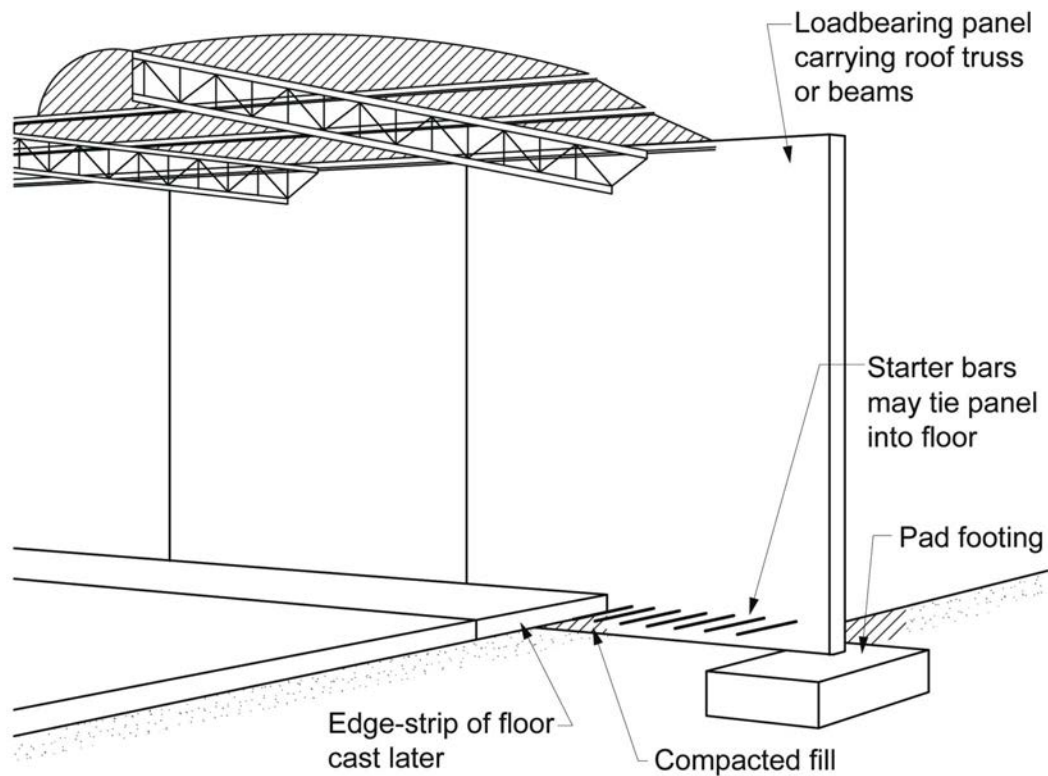

Figure Spec C1.11(2) Typical loadbearing panels required to comply with Specification C1.11



3 General requirements for external wall panels

Intent

To provide general requirements for external wall panels which will minimise the risk of them collapsing in a fire and causing death and/or injury.

The concrete shear cone is the element of a panel that provides the bulk of the interconnection or fixing load capacity of the panel to the main structure. The aim of [Clause 3\(a\)](#) is to provide some attachment to the panel after the concrete shear cone has failed during a fire. See [Figure Spec C1.11\(3\)](#).

Figure Spec C1.11(3) Typical anchor bars for inserts

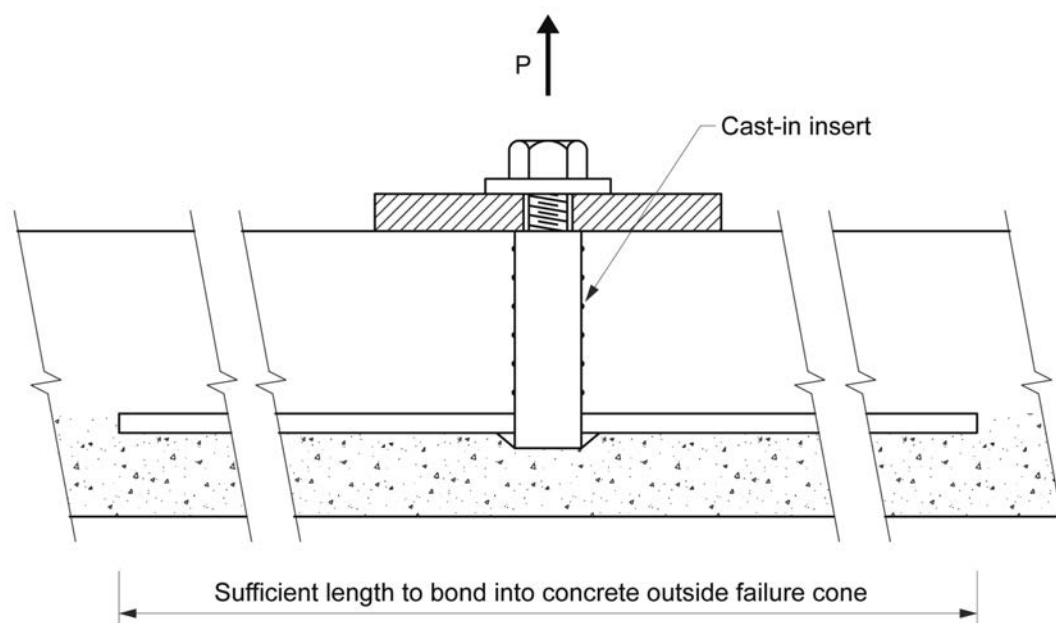

Clause 3(b) sets out the strength capacity required for top inserts or fixings so that the collapsing framework or roof structure will pull the panel inwards. See Figure Spec C1.11(4). The value for outward displacement of one tenth of the panel's height is based on observations of deflections on buildings during a fire.

Figure Spec C1.11(4) Forces to pull panel inwards

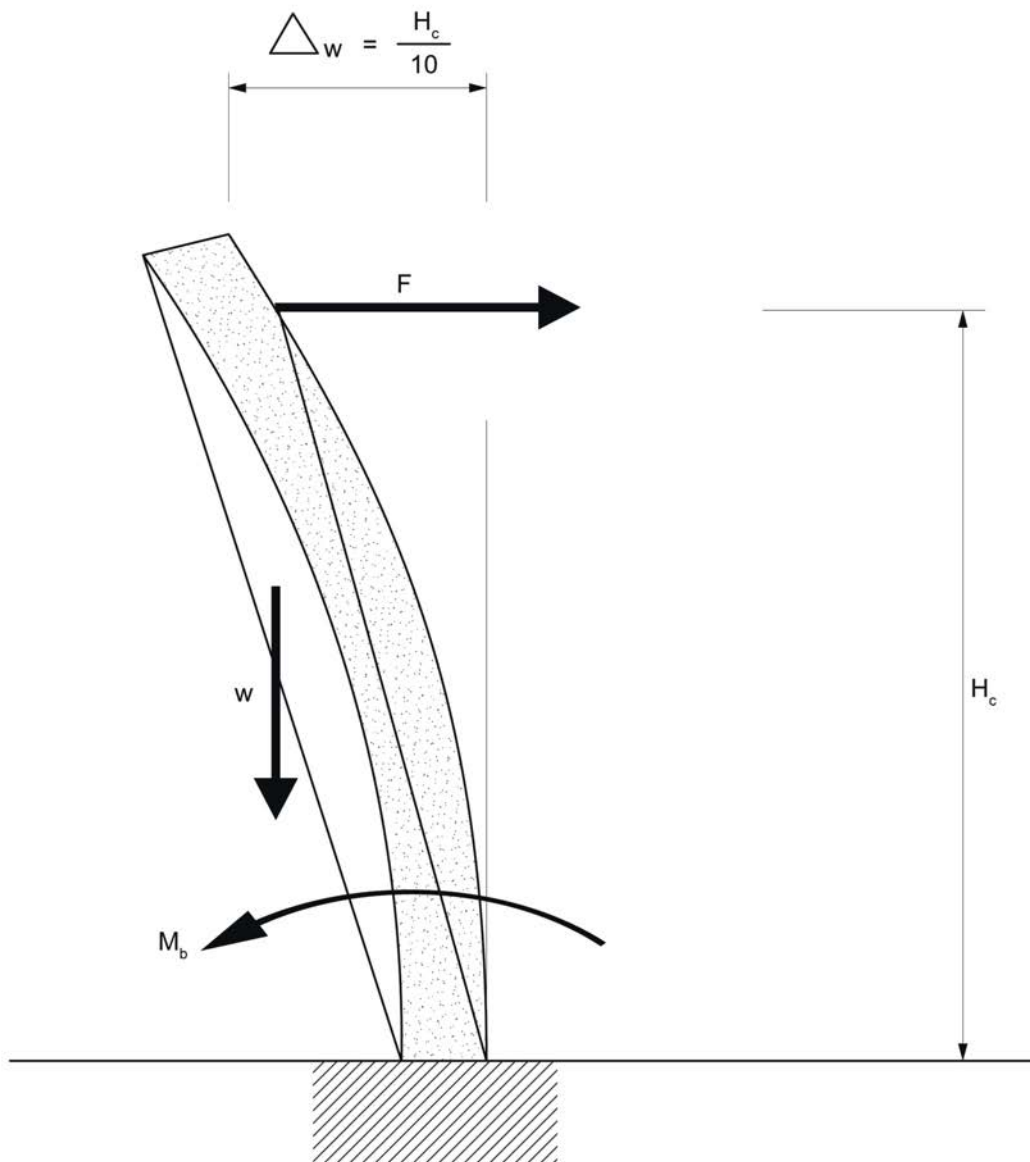

Drilled-in inserts and clips will suffer a greater strength loss from exposure to fire than cast-in inserts. The difference between the factor of two given in [Clause 3\(b\)](#) and of six in [Clause 3\(c\)](#) is based on engineering principles.

The lateral supporting members referred to in [Clause 3\(d\)](#), for “tilt-up type buildings”, may be roof beams or trusses. Where the wall panels are supported by eaves tie members, [Clause 3\(d\)](#) requires that calculation of the forces in the eaves tie take into account the geometry of the deformations of the eaves tie. [Figure Spec C1.11\(5\)](#) illustrates this requirement.

Figure Spec C1.11(5) Forces in eaves tie

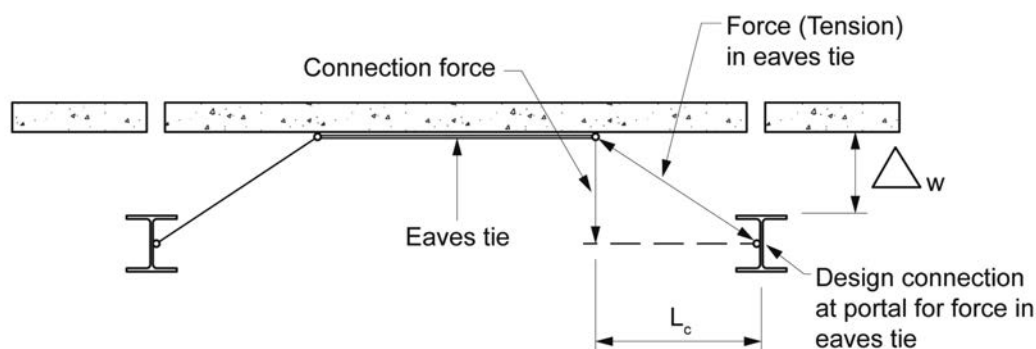

When applying the provisions of [Clause 3\(e\)](#), panels used in a group have to be actually “designed to act as one unit”. It is not enough for the designer just to nominate the number of panels that are to act together.

While [Specification C1.11](#) mostly applies to vertically spanning panels, [Clause 3\(f\)](#) addresses specific provisions applicable to horizontally spanning panels.

4 Additional requirements for vertically spanning external wall panels adjacent to columns

Intent

To provide some additional requirements to enhance the safety of vertically spanning external wall panels which are adjacent to columns.

Observation of the effects of fires shows that during a fire:

- concrete panel walls tend to bow away from a fire;
- steel framework softens; and
- steel columns tend to deflect into the building.

These results create large forces on fixings of concrete wall panels to steel columns. Accordingly, [Clause 4\(a\)](#) requires that connections minimise the effect of such forces.

The provisions of [Clause 4\(b\)](#) provide two means of complying with [Clause 4\(a\)](#). However, they may not be the only means. [Clause 4\(a\)](#) is a performance criterion.

[Clause 4\(b\)](#) provides two strategies for the designer to adopt to minimise fire induced forces on the means used to fix vertically spanning concrete wall panels to steel columns.

If the supporting framework is a material other than steel, such as concrete or timber, the differential deflections assumed by [Clause 4](#) will not occur, and the requirements of [Clause 4\(b\)\(i\)](#) and [\(ii\)](#) will be inappropriate.

[Clause 4\(b\)\(i\)](#) suggests a design of a fixing that will accommodate the expected differential displacement. [Figure Spec C1.11\(6\)](#) illustrates possible solutions to provide for the deflections. The magnitude of the differential deflection given in [Clause 4\(b\)\(i\)\(A\)](#) and [\(B\)](#) is based on observations of buildings under fire conditions.

The solution referred to in [Clause 4\(b\)\(ii\)](#) depends on fixing the concrete panel to the eaves tie member, and taking up the differential deflection in the eaves tie member. The distance this connection must be made away from the column is specified.

If this option is taken, the eaves tie member must be designed to comply with [Clause 3\(d\)](#).

Fire resistance

Figure Spec C1.11(6) Typical fixing to accommodate differential deflection under fire

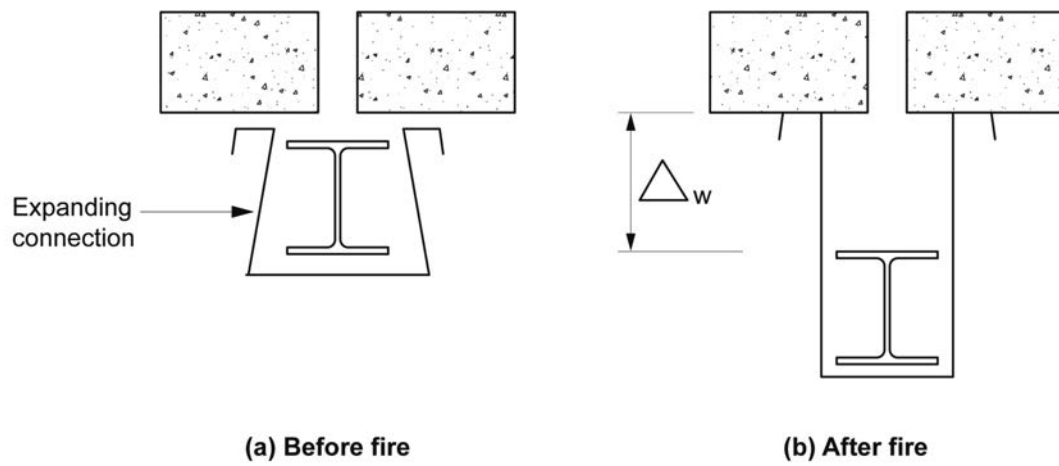

Specification C1.13**Cavity barriers for fire-protected timber****Deemed-to-Satisfy Provisions**

[Specification C1.13](#) sets out requirements for cavity barriers used for fire-protected timber. A cavity barrier is a barrier/enclosure provided to cavities within, around or adjacent to fire-protected timber. The purpose of a cavity barrier is to limit the spread of fire, smoke and hot gases to other parts of a building in the event of a fire. A cavity barrier is used under [C1.13](#) to permit fire-protected timber to be used in lieu of non-combustible material.

The requirements for cavity barriers in [Specification C1.13](#) include but are not limited to:

- the location of cavity barriers, i.e. junctions between fire-resisting floor/ceiling assemblies and fire-resisting walls;
- minimum thickness of timber used as a barrier;
- minimum thickness of insulation; and
- the method to determine the FRL of the cavity barrier.

Specification C1.13A

Fire-protected timber

1 Scope

Intent

To set out the requirements for fire-protected timber.

Specification C1.13a includes the requirements for fire-protected timber and procedures for determining the time at which the temperature at the interface between the protection system and a fire-protected timber element is exceeded.

2 Requirements

2.1 General requirements

Intent

To specify the protection requirements for fire-protected timber.

Where fire-protected timber is used, it must be provided with protection so as to achieve the FRL required of the building element.

In addition, the timber must have either of the following:

- a non-combustible fire-protective covering which achieves a resistance to the incipient spread of fire of not less than 45 minutes when tested in accordance with Section 4 of AS 1530.4 (see Clause 2.1(a)(ii)(A)); or
- at least two layers of 13 mm thick, fire-protective grade plasterboard fixed in the manner required to achieve the required FRL of the element (see Clause 2.1(a)(ii)(B)).

Figure Spec C1.13a Fire-protected timber

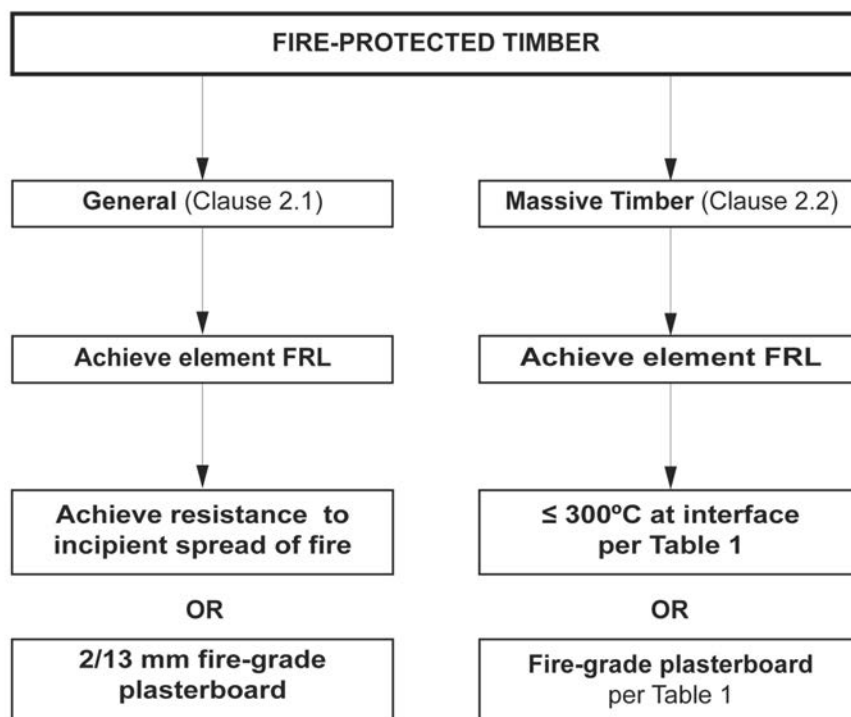

Fire resistance

The covering required by [Clause 2.1\(a\)\(ii\)](#) part or all of the system used to protect the timber in order to achieve the required FRL of the building element.

[Clause 2.1\(a\)\(ii\)\(A\)](#) separates the testing requirements into two sub-clauses; [Clause 2.1\(a\)\(ii\)\(A\)\(aa\)](#) for horizontal elements and [Clause 2.1\(a\)\(ii\)\(A\)\(bb\)](#) for other elements.

For testing of horizontal elements, the test must be conducted in accordance with Section 4 of AS 1530.4. The resistance to the incipient spread of fire is deemed to have failed at the time when the maximum temperature recorded by thermocouples located on the unexposed face of the element lining exceeds 250°C.

The requirements for the testing of other than horizontal elements are contained in [Clause 2.1\(a\)\(ii\)\(A\)\(aa\)](#). For the purpose of measuring temperatures in accordance with this Clause, thermocouples complying with clause 2.2.3.1 of AS 1530.4 shall be positioned at the following locations:

For wall systems and the like:

- Five thermocouples shall be evenly distributed to monitor the temperature on the unexposed surface of the fire-protective covering at the centre of the specimen and at the centre of each quarter section.

For column systems and the like:

- Thermocouples shall be positioned at all locations considered to be critical on the unexposed surface of the fire-protective covering.

For all systems:

- For timber framed systems, padded thermocouples shall be located in a clear space on the unexposed face of the fire-protected covering and shall not be located at the timber interface.
- For monolithic timber systems, thermocouples (without insulating pads) shall be located at the interface of the fire-protective covering and the timber.
- The thermocouples shall not be located closer than 200 mm from any joint in the fire-protective covering.
- Where the fire-protective covering is not in contact with the monolithic timber, the surface of the timber is deemed to be the interface.
- The acceptance criterion is the minimum time at which the unexposed face of the fire-protective covering or interface exceeds a maximum temperature of 250°C.

The testing must be carried out in accordance with the Standard Fire Test, or an equivalent or more severe test on the timber element with the proposed non-combustible fire-protective covering fixed in a representative manner and confirmed in a report from an Accredited Testing Laboratory.

2.2 Massive timber

Intent

To specify alternative protection requirements for fire-protected timber which is massive timber.

Fire-protected timber which is massive timber need not comply with [Clause 2.1](#) if it complies with [Clause 2.2](#). Compliance with [Clause 2.2](#) is achieved when all of the following is applied:

- the element is protected to achieve the required FRL (see [Clause 2.2\(a\)\(i\)](#));
- a non-combustible fire-protected covering is applied to the timber which achieves either of the parameters specified in [Table 1](#) (see [Clause 2.2\(a\)\(ii\)](#)); and
- cavities within the fire-protective covering, if present, are filled with non-combustible insulation (see [Clause 2.2\(a\)\(iii\)](#)).

The covering required by [Clause 2.2\(a\)\(ii\)](#) may form part or all of the system used to protect the timber in order to achieve the required FRL of the building element.

The option provided under [Clause 2.2\(a\)\(ii\)\(A\)](#) requires a test to be carried out on a representative specimen. Refer to [Clause 3](#) for test procedures.

Under [Clause 2.2\(a\)\(iii\)](#) the fire-protective covering may be fixed to timber battens so long as any cavities are filled with non-combustible insulation.

3 Determination of the time the timber interface temperature exceeds 300°C for timber at least 75 mm thick

3.1 Form of test

Intent

To provide a test procedure for massive timber.

[Clause 3.1](#) specifies the testing requirements for fire-protected timber. [Clause 3.1\(a\)](#) requires the test to be in accordance with the Standard Fire Test, or to apply an equivalent or more severe test method. The Accredited Testing Laboratory must also provide a report to confirm the time at which the timber interface temperature exceeded 300°C.

The remaining Clauses are specific requirements on how to conduct the test. [Clause 3.1\(b\)](#) requires the test specimen to incorporate representative joints used in the proposed system. The locations where interface temperatures are measured during the test is specified by [Clause 3.1\(c\)](#). The final sub-clause, [Clause 3.1\(d\)](#), specifies the method of measuring the temperature; which is in accordance with AS 1530.4.

3.2 Smaller specimen permitted

Intent

To allow a smaller test specimen to be tested.

[Clause 3.2](#) permits the Accredited Testing Laboratory to conduct a test using a smaller test sample than that required by [Clause 3.1](#), provided:

- the specimen is not less than 1000 mm × 1000 mm and is representative of the proposed construction;
- the fire resistance has already been determined by a full scale test in accordance with AS 1530.4; and
- the Accredited Testing Laboratory defines the limitations of the tested material, i.e. the size limitation to which the actual system can be constructed.

3.3 Acceptance criteria

Intent

To specify the acceptance criteria of the test.

[Clause 3.3](#) specifies that the acceptance criteria is the time at which any of the thermocouples (specified in [Clause 3.1](#)) exceeds 300°C during the test.

Specification C2.5

Smoke-proof walls in health-care and residential care buildings

Deemed-to-Satisfy Provisions

1 Scope

Intent

To prescribe construction requirements for smoke-proof walls required by [C2.5](#) in health-care and residential care buildings.

[Specification C2.5](#) applies to smoke-proof walls in:

- Class 9a health-care buildings; and
- Class 9c buildings.

2 Class 9a health-care buildings

Intent

To prescribe construction requirements for smoke-proof walls required by [C2.5](#) in Class 9a health-care buildings.

[Clause 2](#) applies to smoke-proof walls in Class 9a health-care buildings.

3 Class 9c buildings

Intent

To prescribe construction requirements for smoke-proof walls required by [C2.5](#) in Class 9c buildings.

[Clause 3](#) applies to smoke-proof walls in Class 9c buildings.

The purpose of the smoke-proof walls is to create a “smoke compartment” to stop or limit the spread of smoke to adjoining areas. It is therefore important that all penetrations of the walls and ceiling of the “smoke compartment” be sealed against the penetration of smoke. This includes any light fitting in the flush plasterboard ceiling referred to in [Clause 3\(a\)\(iii\)](#).

A wall lining need only be applied to one side of the wall to achieve compliance with [Clause 3](#).

4 Doorways in smoke-proof walls

Intent

To limit the spread of smoke between smoke-zones by the use of smoke-reservoirs.

Specification C3.4

Fire doors, smoke doors, fire windows and shutters

Deemed-to-Satisfy Provisions

1 Scope

Intent

To prescribe standards for the construction of fire doors, smoke doors, fire windows and fire shutters.

[Specification C3.4](#) contains detailed Deemed-to-Satisfy Provisions that could form part of a solution for achieving the Performance Requirements relevant to:

- fire doors;
- smoke doors;
- fire windows; and
- fire shutters.

2 Fire Doors

Intent

To specify the fire performance of fire doors to achieve compatibility with the fire performance of the walls in which they are located.

Required fire doors must comply with AS 1905.1, which is the construction Standard for fire doors. This Standard in turn requires that fire doors be tested in accordance with AS 1530.4.

In most cases, the BCA requires a fire door to have an FRL of –/60/30. Where a fire door is located in a firewall, a higher FRL is required.

The first criterion of zero minutes is a reference to the structural adequacy of the door. AS 1905.1 does not require a fire door to be tested for structural adequacy.

The final criterion of 30 minutes is a reference to the insulation the door must provide. It is difficult for a fire door to achieve a higher insulation criterion when tested in accordance with AS 1530.4.

Any glass panel in a fire door must not fail through heat radiation during a fire, as measured by the AS 1530.4 test, before the door fails the integrity criterion. If the glass panel fails by radiation, spread of fire could occur due to radiant heat igniting combustible materials.

3 Smoke Doors

Intent

To specify the smoke performance of smoke doors to achieve compatibility with the smoke performance of the walls in which they are located, by minimising the flow of smoke from one side of the door to the other.

[Clause 3.1](#) is a performance criterion for smoke doors. It sets the general requirement that smoke doors must prohibit the passage of smoke from one side to the other; and if glass panels are installed, minimise the risk of injury of people accidentally walking into them. For example, it would generally be acceptable for the panel to be opaque.

To comply with [Clause 3.1](#), a building proponent may choose to comply with [Clause 3.2](#).

Construction deemed-to-satisfy

Intent

To specify the general requirements under the Deemed-to-Satisfy Provisions for the construction of smoke doors.

Under [Clause 3.2\(a\)](#), the leaves of a smoke door which is intended to achieve the requirements of [Clause 3.1](#) must swing in both directions, or in the direction of travel. This means that they cannot be sliding doors or roller shutters.

To make sure that a door is adequately smoke sealed during a fire:

- the doors must achieve a resistance to smoke at 200°C for 30 minutes. To achieve this, the door leaves

Fire resistance

can be at least 35 mm thick solid core timber, or of some other construction if the building proponent can satisfy the appropriate authority that it will achieve this;

- the leaves must be fitted with smoke seals;
- the door must normally be closed, or automatic-closing;
- where the door is automatic-closing, it must be activated by smoke detectors which comply with the relevant provisions of AS 1670.1 and are located as specified in [Clause 3.2\(d\)\(ii\)\(A\)](#). Under [Clause 3.2\(d\)\(ii\)\(B\)](#), the doors release and close in a power failure; and
- where the doors are opened manually, they must return to the closed position each time they are opened.

[Clause 3.2](#) requires glazing in smoke doors to comply with AS 1288. The glazing must be made apparent by opaque construction if it is capable of being mistaken for an unobstructed opening as part of an exit. This is achieved by complying with the requirements of [Clause 3.2\(g\)](#). The intent of [Clause 3.2\(g\)](#) is not to permit the glazing in smoke doors to be entirely of clear construction.

There is currently some discussion regarding whether or not seals around smoke resistant doors are required to achieve the same resistance to smoke at 200°C in the same manner as the smoke door leaves under [Clause 3.2\(b\)\(i\)](#). Any queries on this matter should be referred to the State or Territory body responsible for building regulatory matters.

4 Fire Shutters

Intent

To enable the fire performance of fire shutters to be compatible with the fire performance of the walls in which they are located.

Under [Clause 4\(a\)\(i\)](#), required fire shutters must have the required FRL determined in accordance with [Schedule 5](#). [Schedule 5](#) requires that a prototype of the element being tested must be subjected to the Standard Fire Test. See AS 1530.4.

In order for a fire shutter to comply with [Specification C3.4](#), it must be identical to a prototype tested in accordance with AS 1530.4.

When testing the FRL of fire shutters in accordance with AS 1530.4, the structural adequacy criteria is not included. Hence, these criteria are not included in the required FRL of a fire shutter.

Under [Clause 4\(a\)](#), non-metallic fire shutters:

- must be identical to a prototype tested in accordance with AS 1530.4;
- must not be larger than the tested prototype; and
- during the AS 1530.4 testing, the temperature on the non-furnace side of the shutter must not exceed 140 K during the first 30 minutes of the test.

The reason for the last condition is to reduce the amount of radiant heat on the non-fire side of the shutter, which could ignite combustible materials.

Under [Clause 4\(b\)](#), metallic fire shutters can only be used if not prohibited by [C3.5](#). Metallic fire shutters are not permitted in certain situations because of the risk that fire could spread by way of radiated heat facilitated by the metal construction of the shutter. Such radiated heat could ignite combustible materials on the non-fire side of the shutter.

If permitted, metallic fire shutters must either comply with AS 1905.2 or be in accordance with [Clause 4\(a\)](#), in that they:

- must be identical to a prototype tested in accordance with AS 1530.4;
- must not be larger than the tested prototype; and
- during the AS 1530.4 testing, the rise in temperature on the non-furnace side of the shutter must not exceed 140 K during the first 30 minutes of the test.

5 Fire Windows

Intent

To specify the fire performance of fire windows to achieve compatibility with the fire performance of the walls in which they are located.

Fire resistance

Required fire windows must have the required FRL determined in accordance with [Schedule 5](#).

[Schedule 5](#) requires that a prototype of the element being tested must be subjected to the Standard Fire Test. See AS 1530.4.

Therefore, in order for a fire window to comply with [Specification C3.4](#), it must be identical to a prototype tested in accordance with AS 1530.4.

When testing the FRL of fire windows in accordance with AS 1530.4, the structural adequacy and insulation criteria are not included. Hence these criteria are not included in the required FRL of a fire window.

Specification C3.15**Penetration of walls, floors and ceilings by services****Deemed-to-Satisfy Provisions**

[Specification C3.15](#) sets out details of permissible service penetrations through walls, floors and ceilings, and was developed using building practices that are in general use. The Specification permits the use of metal pipe systems and conduits (but not flue pipes) which do not satisfy the insulation criteria of AS 1530.4, provided certain criteria are met.

[Specification C3.15](#) does not apply to larger diameter electrical cables (i.e. where the opening is larger than those specified in [Clause 5\(a\)](#) and [\(b\)](#) of 2000 mm² or 500 mm²). This does not mean that larger diameter electrical cables cannot be approved under [C3.15](#). Larger diameter electrical cables can be approved under [C3.15\(a\)\(i\)](#) or, if necessary, as a Performance Solution.

Access and egress

Section D	Access and egress
Part D1	Provision for escape
Part D2	Construction of exits
Part D3	Access for people with a disability

Section D Access and egress

Section D Access and egress

Objective

DO1

Functional Statements

DF1

DF2

Performance Requirements

DP1 Access for people with a disability

DP2 Safe movement to and within a building

DP3 Fall prevention barriers

DP4 Exits

DP5 Fire-isolated exits

DP6 Paths of travel to exits

DP7 Evacuation lifts

DP8 Carparking for people with a disability

DP9 Communication systems for people with hearing impairment

Verification Methods

DV1 Wire barriers

DV2 Access to and within a building

DV3 Ramp gradient, crossfall, surface profile and slip resistance for ramps used by wheelchairs

Part D1 Provision for escape

Objective

Functional Statements

Performance Requirements

Deemed-to-Satisfy Provisions

D1.0 Deemed-to-Satisfy Provisions

D1.1 Application of Part

D1.2 Number of exits required

D1.3 When fire-isolated stairs and ramps are required

D1.4 Exit travel distances

D1.5 Distance between alternative exits

D1.6 Dimensions of exits and paths of travel to exits

D1.7 Travel via fire-isolated exits

D1.8 External stairways or ramps in lieu of fire-isolated exits

D1.9 Travel by non-fire-isolated stairways or ramps

D1.10 Discharge from exits

D1.11 Horizontal exits

D1.12 Non-required stairways, ramps or escalators

D1.13 Number of persons accommodated

D1.14 Measurement of distances

D1.15 Method of measurement

D1.16 Plant rooms, lift motor rooms and electricity network substations: Concession

Part D2 Construction of exits

Objective

Functional Statements

Performance Requirements

Deemed-to-Satisfy Provisions

D2.0 Deemed-to-Satisfy Provisions

D2.1 Application of Part

- D2.2 Fire-isolated stairways and ramps
- D2.3 Non-fire-isolated stairways and ramps
- D2.4 Separation of rising and descending stair flights
- D2.5 Open access ramps and balconies
- D2.6 Smoke lobbies
- D2.7 Installations in exits and paths of travel
- D2.8 Enclosure of space under stairs and ramps
- D2.9 Width of stairways and ramps
- D2.10 Pedestrian ramps
- D2.11 Fire-isolated passageways
- D2.12 Roof as open space
- D2.13 Goings and risers
- D2.14 Landings
- D2.15 Thresholds
- D2.16 Barriers to prevent falls
- D2.17 Handrails
- D2.18 Fixed platforms, walkways, stairways and ladders
- D2.19 Doorways and doors
- D2.20 Swinging doors
- D2.21 Operation of latch
- D2.22 Re-entry from fire-isolated exits
- D2.23 Signs on doors
- D2.24 Protection of openable windows
- D2.25 Timber stairways: Concession

Part D3 Access for people with a disability

Objective

Functional Statements

Performance Requirements

Deemed-to-Satisfy Provisions

- D3.0 Deemed-to-Satisfy Provisions
- D3.1 General building access requirements
- D3.2 Access to buildings
- D3.3 Parts of buildings to be accessible
- D3.4 Exemptions
- D3.5 Accessible carparking
- D3.6 Signage
- D3.7 Hearing augmentation
- D3.8 Tactile indicators
- D3.9 Wheelchair seating spaces in Class 9b assembly buildings
- D3.10 Swimming pools
- D3.11 Ramps
- D3.12 Glazing on an accessway

Specification D1.12 Non-required stairways, ramps and escalators

Deemed-to-Satisfy Provisions

Specification D3.6 Braille and tactile signs

Deemed-to-Satisfy Provisions

- 1 Scope
- 2 Location of braille and tactile signage
- 3 Braille and tactile sign specification
- 4 Luminance contrast
- 5 Lighting
- 6 Braille

Specification D3.10 Accessible water entry/exit for swimming pools

Deemed-to-Satisfy Provisions

- 1 Scope
- 2 Fixed or moveable ramp
- 3 Zero depth entry
- 4 Platform swimming pool lift
- 5 Sling-style swimming pool lift
- 6 Aquatic wheelchair

Section D Access and egress

Issues — Part D3 and the relevant performance provisions

Compliance with Disability Discrimination Act 1992 (DDA)

Section 23 of the *Disability Discrimination Act 1992* (DDA) makes it unlawful to discriminate against another person on the ground of the person's disability in relation to a number of aspects of access to, or use of, premises. The DDA also provides that the relevant Minister may, by legislative instrument, formulate standards in relation to any area in which it is unlawful to discriminate against another person on the ground of a disability. The Disability (Access to Premises — Buildings) Standards (Premises Standards) were formulated following requests for improved certainty under the DDA in satisfying its requirements for non-discriminatory access to premises. The BCA provisions for access for people with a disability have been aligned with the technical provisions in the Premises Standards. This results in a uniform set of requirements that will apply both in relation to non-discriminatory access under the DDA and in relation to the requirements for access that must be complied with in order to obtain a building approval under building law.

The Premises Standards have been subject to a 5 yearly review that commenced in 2015 and was completed in May 2016. The review was undertaken by the Commonwealth Department of Industry, Innovation and Science in consultation with the Attorney General's Department, with input provided by the ABCB.

In response to the recommendations of that review, amendments have been made to the BCA.

Objective

DO1

The Objective of this Section is to—

- (a) provide, as far as is reasonable, people with safe, equitable and dignified access to—
 - (i) a building; and
 - (ii) the services and facilities within a building; and
- (b) safeguard occupants from illness or injury while evacuating in an emergency.

Safe, equitable and dignified access—DO1(a)

DO1(a) requires the provision of safe, equitable and dignified access to a building and its services, as far as is reasonable. Several of these terms are explained below.

As far as is reasonable

There may be occasions when the application of a rule is “unreasonable”. Use of the phrase “as far as is reasonable” indicates that the BCA provisions are not absolute. This is consistent with the intent of the DDA.

Equitable

One of the primary intentions of the DDA is to provide people with a disability with the same rights as the rest of the community.

The word “equitable” combines concepts of fairness and equality. It does not mean that all people must be able to do precisely the same thing in the same way. However, if some people can use a building for a particular purpose, then most people should be able to use the building for that purpose.

Examples

If most members of the community enter a building at a particular point, normally the front entrance, people with a disability should be able to enter the same building at that point.

However, this may not mean entry through the same door. For example, a revolving door may not be suitable for guide dogs or wheelchairs. However, people who use guide dogs or wheelchairs should be able to enter the building at an adjacent door.

The concept of “equitable” does not necessarily mean that everybody should be able to access all parts of a building.

Dignified

A person with a disability should be able to gain access to and within a building, and to the services and facilities of buildings, in a manner which is not devaluing or demeaning.

Safeguarding people evacuating—DO1(b)

Access and egress

DO1(b) refers to safeguarding occupants while evacuating in an emergency. This includes people with a disability who cannot independently use exits and may require specific egress arrangements.

Example

A person who is able to walk without assistance is able to reach a public space on an upper level of a building with dignity, perhaps by walking up a flight of stairs. A person with a mobility disability should also be able to access that space with similar dignity. It is unlikely that having to be carried up the stairs would achieve this requirement.

Functional Statements**DF1**

A building is to provide, as far as is reasonable—

- (a) safe; and
 - (b) equitable and dignified,
- access for people to the services and facilities within.

Limitation:

DF1(b) does not apply to a Class 4 part of a building.

DF2

A building is to be provided with means of evacuation which allow occupants time to evacuate safely without being overcome by the effects of an emergency.

Limitation:

DF2 does not apply to the internal parts of a sole-occupancy unit in a Class 2 or 3 building or Class 4 part of a building.

DF2 refines the intention of **DO1(b)**. A building must provide the capacity for occupants to evacuate in a safe and timely manner, without being overcome by the effects of the emergency (for example, smoke, heat or flame in the case of a fire).

DF2 does not apply to the internal parts of any sole-occupancy unit located within a Class 2 or Class 3 building or a Class 4 part. The design of the internal parts of sole-occupancy units is not regulated in regards to egress, as occupants will generally be familiar with egressing the units and the distances to travel to doors leading out of the units will generally not be excessive.

Performance Requirements**DP1 Access for people with a disability**

DP1 refines the intention of **DO1(a)**. A building must, as far as is reasonable, provide safe access for people to all the services and facilities in it.

It also excludes the application of **DP1** to a Class 4 part of a building.

Emphasis on access for people

The required access is for people, including people with a disability.

To the degree necessary

DP1 uses the term “to the degree necessary”. See [A1.0\(3\)\(c\)](#).

DP2 Safe movement to and within a building

DP2 generally sets the performance required for safe movement within a building for most people, including those with a disability.

Safe gradient—DP2(a)

The **DP2(a)** requirement for a safe gradient is to facilitate access and safety for all people, and refers to the crossfall as well as the longitudinal grade.

Doors—DP2(b)

DP2(b) aims to make sure people are not put at risk by doors impeding egress or causing them to be trapped.

Stairways and ramps—DP2(c)

Access and egress

Slip-resistant walking surfaces—DP2(c)(i)

People moving on stairways and ramps should not slip and fall. This is a particular issue during an emergency.

Handrails—DP2(c)(ii)

Handrails may be necessary to assist people using stairways and ramps, particularly in helping them maintain their stability.

Landings for ramps—DP2(c)(iii) and (iv)

Under DP2(c)(iii) and (iv), it is necessary to provide landings for ramps as well as stairways. As with stairways, the landings on a ramp are used as a place to rest when necessary. Landings at doorways provide a level plane from which doors may be safely opened.

Safe passage on stairways—DP2(c)(v)

DP2(c)(v) requires that a stairway must be suitable for the safe passage of people, and appropriate to the nature, volume and frequency of use. This is a reference to the riser and going of the treads, and the width of the stairway. Hence the rise, going and width may differ between buildings as long as a safe passage is provided.

DP3 Fall prevention barriers

DP3 principally relates to barriers which are meant to prevent people accidentally falling through an opening, etc.

Barriers and children

Children are at particular risk of falling off, over or through ineffectively designed or constructed barriers. Accordingly, DP3 aims to make sure a barrier does not facilitate climbing to reduce the likelihood of children being able to climb over a barrier or fall through a barrier.

Use of windows as barriers

Provided it achieves the requirements of DP3 (such as having the required strength and not opening far enough to permit the passage of children), a window can act as a barrier. In other words, it will stop people, including children, from accidentally falling.

DP3 limitations**Areas where barriers may interfere with use**

DP3 does not apply where the use of a barrier or the like would be inconsistent with the use of the area.

Examples

Loading docks, where a barrier would inhibit the unloading of trucks or other vehicles.

The stage of a theatre, where a barrier would interfere with the viewing of the performance. Railway platforms, where a barrier would result in people not being able to get on or off a train.

Fire-isolated stairways or ramps

Fire-isolated stairways or ramps and the like are exempted from DP3(g) because unsupervised children are unlikely to have access to such areas.

Class 7 and Class 8 buildings

Class 7 (other than carparks) and Class 8 buildings are exempted from DP3(g). This is for two primary reasons:

- unsupervised children are unlikely to have access to such buildings; and
- large numbers of people, particularly members of the general public unfamiliar with the building or its environs, are unlikely to have access to such buildings.

Carparks are not included in this exemption from compliance with DP3(g) as they are often public in nature.

DP4 Exits**Number, dimensions and distribution of exits**

DP4 is the Performance Requirement for the number, dimensions and distribution of exits.

DP4(a)—the travel distance will affect the time taken to evacuate the building. Greater distances will require greater evacuation times.

DP4(b)—the number of occupants can affect the evacuation time. A greater number of people will require a greater evacuation time through a single exit. This time can be reduced by such means as:

- increasing the number and/or width of the exits, or
- reducing the travel distance to the exits by utilising other options for their location.

DP4(b)—the mobility and other characteristics of occupants will have a direct effect on the evacuation time. Matters to be

Access and egress

considered include whether the occupants are likely to have limited mobility or capacity to find their way unassisted, and the type and the extent of that limitation. For example, people may be in beds or have some kind of ambulatory-related disability, or may be asleep or anaesthetised, or may be under the influence of drugs or otherwise confused.

DP4(c)—the function or use of the building will have an effect on the building’s fire load.

DP4(d)—the height of the building will affect the distance a person escaping from the building would have to travel. The height therefore has an impact on the evacuation time.

DP4(e)—to ensure the safety of occupants, an exit from a level below ground level needs to satisfy different criteria to that of an exit from levels above ground. For example, an exit from a basement must take account of criteria such as:

- the difficulty in naturally venting smoke from a fire because of the lack of windows; and
- the need for occupants to evacuate in the direction of smoke travel (which will be upwards). This is the opposite to upper storeys, where people would be evacuating downwards and the smoke would be travelling upwards.

DP5 Fire-isolated exits

DP5 is the Performance Requirement for determining when fire-isolated exits are necessary to provide protection for evacuating occupants.

Use of fire-isolated exits

Fire-isolated exits are used in multi-storey buildings to:

- enable people to evacuate safely past a storey on fire;
- facilitate fire brigade access to carry out operations such as search and rescue and fire-fighting; and
- minimise the distance people need to travel in a fire affected area before they are able to access a “safe place”, such as a fire-isolated stairway.

Criteria for fire-isolated exits

Fire-isolated exits must be installed when necessary, and must be appropriate to a number of factors.

DP5(a)—the number of storeys connected by the exit will affect the distance a person has to travel while escaping from the building, and, therefore, will also affect the evacuation time.

DP5(b)—fire safety systems are expected to reduce the rate of fire spread (e.g. if a sprinkler system is installed, it will either extinguish the fire or reduce its growth rate), therefore allowing greater evacuation times.

DP5(c)—the function or use of the building will have an effect on the building’s fire load.

DP5(d)—the number of storeys passed through by the exits will affect the distance a person escaping from the building would have to travel, and therefore has an impact on the evacuation time.

DP5(e)—“fire brigade intervention” is the terminology used in the BCA to determine the time taken by the brigade to arrive at the building (presuming that the building is in an area served by a fire brigade) and any likely action of its officers (e.g. whether they will undertake a search and rescue operation, and the likely time for that operation).

DP6 Paths of travel to exits

DP6 is the Performance Requirement for paths of travel to an exit. It is separate from **DP4** because the needs for paths of travel are often different from the needs for exits.

Class 2 or Class 3 buildings or Class 4 parts

The limitation attached to **DP6** indicates that it does not apply within a sole-occupancy unit of a Class 2 or Class 3 building or Class 4 part. The design of the internal parts of sole-occupancy units is not regulated in regards to egress, as occupants will generally be familiar with egressing the units and the distances to travel to doors leading out of the units will generally not be excessive.

The exception to the general rule concerning the path of travel to the door leading out of a sole-occupancy unit of a Class 2 or Class 3 building or Class 4 part is when smoke hazard management matters are being considered. For more information on the reason for this exception, refer to [Part E2](#).

Criteria for paths of travel to exits

As set out in **DP6**, paths of travel to exits must have dimensions appropriate to a number of factors, including:

- **DP6(a)**—the number of occupants can affect the evacuation time—the greater the number of people the greater the evacuation time required (this time can be reduced by increasing the number and/or width of (exits) and paths of travel to exits);
- **DP6(a)**—the mobility and other characteristics of occupants will have a direct impact on the evacuation time—matters to be considered include whether the occupants are likely to have limited mobility or capacity to find

Access and egress

their way unassisted, and the type and the extent of that limitation (for example, people may be in beds or have some kind of ambulatory-related disability, or may be asleep or anaesthetised, or may be under the influence of drugs or otherwise confused); and

- **DP6(b)**—the function or use of the building takes account of any special provisions such as movement of beds in hospitals.

DP7 Evacuation lifts

DP7 lists those issues which must be considered when it is intended a lift be used in addition to the existing required exits as a means of assisting people in the evacuation of building occupants including those with a disability or other health conditions in an emergency.

DP7(a) to **(d)** require similar consideration to that required by **DP4**, but are additional specific requirements where a lift is proposed to assist in evacuation.

The intent of **DP7(e)** to **(h)** is to ensure a high level of safety and engineering reliability in a solution which includes a lift and requires that appropriate consideration be given to a lift's reliability, interaction with other fire safety systems of the building, and building evacuation procedures under evacuation conditions.

A solution would more commonly utilise a passenger lift, however it may include a goods lift as the primary intent is that compliance is achieved with the safety aspects required by **DP7(a)** to **(h)**.

DP8 Carparking for people with a disability

DP8 is the Performance Requirement for carparking spaces for people with a disability.

If carparking is provided in or around a building, suitable carparking spaces must be provided for people with a disability. These spaces are required to be larger than a conventional space. This facilitates a person transferring from a vehicle to a wheelchair or other mobility aid positioned between vehicles.

DP9 Communication systems for people with hearing impairment

DP9 is the Performance Requirement for hearing augmentation and refines the intention of **DO1(a)**. A building must, as far as is reasonable, provide safe access for people to all the services, facilities and features. **DP9** relates to the inclusion of hearing augmentation systems where an inbuilt audible communication system is used for entry, information, entertainment, or provision of a service. This requirement is not intended to apply to equipment such as televisions, music systems etc that are provided for the purposes of improving an occupant's general comforts and ambience but which are not associated with the specific functioning of the building or specific services or entertainment provided.

It does not apply to a Class 4 part of a building.

It is also important to note that it does not apply to an inbuilt communication system used only for emergency warning purposes.

Verification Methods

DV1 Wire barriers

DV1 is a means to verify whether or not a proposed wire barrier achieves the requirements of **DP3(f)** and **(g)**, in other words whether the wire barrier is—

- constructed to prevent people from falling through the barrier; and
- capable of restricting the passage of children.

DV1 cannot be used to verify compliance with the other provisions of **DP3**.

It is not compulsory for a designer to use **DV1**. The designer has the choice of using—

- **DV1** to verify that the proposal achieves **DP3(f)** and **(g)**; or
- the Deemed-to-Satisfy Provisions in **D2.16(d)**.

As set out in **DV1(a)**, the Verification Method may be carried out on—

- a prototype that is identical to that proposed to be installed; or
- a wire barrier installed on site.

The meaning of the phrase “prototype that is identical to that proposed to be installed” is similar to that for the testing of prototypes for fire resistance. That is, it must be identical with respect to the type of wire, the wire diameter, the number of lays, the wire tension, the post spacing and size, etc.

The test procedure is slightly different for barriers with horizontal or near horizontal wires and vertical wires or near vertical

Access and egress

wires (see the test procedures set out in [DV1\(c\)\(ii\)](#)).

If [DV1](#) is to be used for horizontal or near horizontal wire barriers, [DV1\(c\)\(vi\)](#), whereby the deflection of the tensioned wires is measured as part of the prototype test, allows a simple method of checking that the barrier wires installed on site have been installed at the required tension if a tension gauge is not available.

DV2 Access to and within a building

This Verification Method allows for a design based on occupant needs and characteristics by using a reference building to verify that the proposed building provides at least equivalent access to and within a building ([DP1](#)), as well as specific areas of a building ([DP2](#), [DP6](#), [EP3.4](#) and/or [FP2.1](#)).

The basis of this Verification Method is that these Performance Requirements are dependent on “the number, mobility and other characteristics of occupants”. As a fully developed set of occupant characteristics, as covered by the NCC, is not currently available, the Verification Method uses the reference building approach to show equivalent access has been provided by the proposed building.

Further information on the use of the Verification Method, as well as the overlap with the *Disability (Access to Premises—Buildings) Standards 2012* is available in the ABCB’s Access to and Within a Building Handbook.

DV3 Ramp gradient, crossfall, surface profile and slip resistance for ramps used by wheel-chairs

DV3 is a means to verify wheelchair rolling resistance and ramp design in order to meet the requirements of [DP2](#). For further guidance, refer to the ABCB’s Ramps Verification Method Handbook.

Part D1 Provision for escape

Objective

Functional Statements

Performance Requirements

The Objective and Functional Statements for [Section D](#) are at the beginning of [Section D](#) of this Guide. The Performance Requirements for [Part D1](#) precede [Part D1](#).

Deemed-to-Satisfy Provisions

D1.0 Deemed-to-Satisfy Provisions

Intent

To clarify that the requirements of [DP1](#) to [DP6](#), [DP8](#) and [DP9](#) will be satisfied if compliance is achieved with [Parts D1](#), [D2](#) and [D3](#) in the case of all buildings, [Part G3](#) in the case of buildings with an atrium, [Part G4](#) in the case of buildings in alpine areas, [Part G6](#) in the case of occupiable outdoor areas, [Part H1](#) in the case of theatres, stages and public halls, and [Part H2](#) for public transport buildings. [DP7](#) is only required to be complied with if lifts are to be used to assist occupants to evacuate.

Most buildings

Where a solution is proposed to comply with the Deemed-to-Satisfy Provisions, [D1](#) clarifies that for most buildings compliance with [Parts D1](#), [D2](#) and [D3](#) will achieve compliance with [DP1](#) to [DP6](#), [DP8](#) and [DP9](#). The exceptions to this general rule are set out below.

Buildings with an atrium

If the building contains an atrium, it must comply with [Part G3](#) in addition to [Parts D1](#), [D2](#) and [D3](#).

Buildings with an occupiable outdoor area

If the building contains an occupiable outdoor area, it must comply with [Part G6](#) in addition to [Parts D1](#), [D2](#) and [D3](#).

Theatres, stages and public halls

A building which comprises a theatre, stage or public hall must comply with [Part H1](#) in addition to [Parts D1](#), [D2](#) and [D3](#).

Atrium and theatre, stage or public hall

If the building contains an atrium and one or more of a theatre, stage or public hall, it must comply with [Parts D1](#), [D2](#), [D3](#), [G3](#) and [H1](#).

Buildings in alpine areas

A building located in an Alpine Area must comply with [Part G4](#) in addition to [Parts D1](#), [D2](#) and [D3](#).

Public transport buildings

A building associated with public transport services, such as railway stations, bus interchanges, airports and ferry terminals must comply with [Part H2](#) in addition to [Parts D1](#), [D2](#) and [D3](#).

Where a Performance Solution is proposed, the relevant Performance Requirements must be determined in accordance with [A2.2\(3\)](#) and [A2.4\(3\)](#) as applicable. (See commentary on [Part A2](#)).

D1.1 Application of Part

Intent

To exempt internal parts of sole-occupancy units in Class 2 and Class 3 buildings and Class 4 parts from the [Part D1](#) Deemed-to-Satisfy Provisions.

Sole-occupancy units—Class 2 and Class 3

The [Part D1](#) Deemed-to-Satisfy Provisions do not apply within a sole-occupancy unit of a Class 2 or Class 3 building and Class 4 parts.

Access and egress

This is because most occupants are familiar with the layout of their unit. The units are small in area compared to sole-occupancy units in other classes of building. They will also have a low level of occupancy and a lower fire load than most commercial and industrial buildings.

Additionally, such units will be separated from the rest of the building by fire-rated construction, or sprinklers will be installed. Except when considering smoke-hazard management matters, the path to the door leading out of sole-occupancy units is not regarded as part of the path of travel to an exit. See [Part E2](#).

D1.2 Number of exits required

Intent

To require the provision of sufficient exits to enable safe egress in case of an emergency.

All buildings—D1.2(a)

Under [D1.2\(a\)](#), all buildings must have at least one exit from each storey. The remainder of [D1.2](#) sets out the circumstances in which more than one exit may be required.

Why do some buildings require multiple exits?

The purpose of regulatory control over the number of exits in a building is to maximise the opportunities for people to have egress from the building in an emergency.

Egress from some buildings can be very difficult (for example, particularly tall or large buildings, or even small buildings which have a complex passageway design). It may be necessary to provide several alternative exits.

Horizontal exits

While a number of the [D1.2](#) provisions refer to “horizontal exit”, they do not require the installation of a horizontal exit. Rather, where a horizontal exit exists or is proposed, at least two additional exits must be provided. Where there is no horizontal exit, there must still be at least two exits.

Class 2 to Class 8 buildings—D1.2(b)

The [D1.2\(b\)\(i\)](#) provision regarding an effective height of 25 metres recognises the effective operating height for fire brigade ladders and other fire-fighting and rescue equipment. Above this height, fire-fighting, rescue and egress problems increase considerably.

D1.2(b)(ii)—Class 2 and Class 3 buildings complying with C1.5

[C1.5](#) provides a concession for Class 2 and Class 3 buildings (having a rise in storeys of two), in that if they comply with certain conditions they may be of Type C construction. In order to qualify for that concession such buildings must have at least 2 exits.

This provision recognises that Class 2 and Class 3 buildings constructed in accordance with [C1.5](#) include additional evacuation provisions.

Basements—D1.2(c)

“Basement” is not defined in the BCA. A basement is regarded as a below-ground-level storey not counted in the rise in storeys.

Any basement in excess of the minimum floor area specified in [D1.2\(c\)\(i\)](#) which has a travel distance to an exit in excess of that specified in [D1.2\(c\)\(ii\)](#), must have at least two exits. The reason for this is that basements present difficulties in terms of egress and fire-fighting. These include:

- the difficulty in naturally venting smoke from a fire because of the lack of windows; and
- the need for occupants to evacuate in the direction of smoke travel. This is the opposite to upper storeys, where people would be evacuating downwards and the smoke travelling upwards.

Class 9 buildings—D1.2(d)

All Class 9 buildings

[D1.2\(d\)\(i\)](#) covers Class 9 buildings with a rise in storeys of more than six (additional to the provisions which apply to Class 2 to Class 8 buildings) and Class 9 buildings with an effective height of more than 25 metres (which is the same as for Class 2 to Class 8 buildings, and recognises the effective operating height for fire brigade ladders and other fire-fighting and rescue equipment).

[D1.2\(d\)\(i\)](#) recognises the emergency egress requirements for Class 9 buildings. Such buildings could contain large numbers of people who may be unfamiliar with the building’s egress provisions. They might also be confused and in various stages of immobility.

[D1.2\(d\)\(i\)](#) does not refer to “whichever is the lesser”, nor, for that matter, “whichever is the greater”—meaning that both are applicable.

Access and egress

Additional requirements for some Class 9 buildings

In [D1.2\(d\)\(ii\)–\(vi\)](#), and [D1.2\(e\)](#) and [\(f\)](#), the BCA recognises that some Class 9 buildings (patient care areas, aged care buildings, early childhood centres, schools, spectator stands, storeys or mezzanines containing more than 50 people as calculated under [D1.13](#)) present difficult evacuation conditions (requiring two exits additional to any horizontal exits) because of such factors as:

- the age and nature of the occupants;
- the density of occupation (for example, occupants per m²); and
- the unfamiliarity of occupants with the emergency evacuation requirements.

Exits must be accessible—[D1.2\(g\)](#)

There is little point requiring exits if they are not accessible at all times. [D1.2\(g\)](#) requires that occupants must be able to access an exit. Where two or more exits are required, at least two exits (allowing for the fact that one of the exits may be made inaccessible by an emergency, such as a fire) should be accessible.

Such access must not be through another sole-occupancy unit because access to the unit may be locked or barred.

D1.3 When fire-isolated stairs and ramps are required

Intent

To indicate when fire-isolated stairways and ramps are required to enable safe egress in case of a fire.

D1.3 and DP5

[D1.3](#) comprises the Deemed-to-Satisfy Provisions for [DP5](#).

Purpose of fire-isolated exits

Fire-isolated exits are required in multi-storey buildings to enable people to evacuate past a storey on fire. They also help the fire brigade carry out search and rescue and fire-fighting.

Such exits minimise the distance people need to travel in a fire-affected area before accessing a “safe place”, such as a fire-isolated stairway.

Fire-isolated exits may be:

- fire-isolated stairways;
- fire-isolated ramps; and
- fire-isolated passageways connected to fire-isolated stairways or ramps.

[D1.3](#) sets out when stairways and ramps connecting storeys in a building are required to be fire-isolated. This only applies to a stairway or ramp serving as a required exit. Therefore, from the definition of “exit”, [D1.3](#) only applies to those providing egress to a road or open space. Combined with the provisions of [D1.2](#) that exits are required from every storey, a stairway or ramp serving as an exit will generally be connecting storeys. However, the term “exit” could also apply to a stairway or ramp from a basement that exits vertically, directly to a road or open space and thus, does not technically connect storeys.

[D1.3](#) only applies to stairways that are required exits and therefore does not apply to stairways between split levels of a single storey of a building or those leading from the front door of a building.

Exceptions

External stairways

Under certain specified conditions, [D1.8](#) permits the use of external stairways in place of fire-isolated stairways.

Class 2 buildings—[D1.3\(a\)\(i\)](#)

[D1.3\(a\)\(i\)](#) permits Class 2 buildings to have non-fire-isolated exits provided they do not connect, pass through or pass by more than three consecutive storeys, plus an extra storey of any classification under specified conditions. The terms “connect”, “pass through” and “pass by” include the following situations:

- Where the exit provides access to the storey.
- Where the exit passes through the storey but does not necessarily provide access to or egress for the storey.
- Where the exit is external to the building, i.e. passes by the storey but does not necessarily provide access to or egress for the storey.

With regard to the allowance for 3 storeys, the BCA assumes that residents of Class 2 buildings tend to be long-term occupants, and aware of their surroundings. This makes them likely to be able to exit quickly without the need for fire-isolated exits.

An extra storey of any classification may be included under certain circumstances where the fire risk associated with the

Access and egress

extra storey is low. The circumstances are:

- where the extra storey is used for a carpark or other ancillary purposes. In Class 2 buildings a carpark usually represents a low fire risk, and is unlikely to have many occupants for any length of time. The inclusion of the extra storey applies when the building only consists of a Class 2 building and a carpark. The building may also include a Class 3 part, however in such a case, the Class 3 portion of the building would control the number of storeys connected by a non-fire-isolated exit (see comments on [D1.3\(a\)\(ii\)](#)); and
- where the building contains a sprinkler system. This concession recognises the ability of sprinkler systems to extinguish or contain a fire thereby allowing additional time for occupants to escape; and
- where the exit is separated from the extra storey by walls having an FRL consistent with those required for a public corridor in a Class 2 or 3 building. By having separating walls with an FRL and by preventing any connection to the extra storey for the purpose of providing access to or egress for that storey, the non-fire-isolated exit is protected from the fire risk associated with the extra storey.

Class 3 buildings—D1.3(a)(ii)

[D1.3\(a\)\(ii\)](#) permits Class 3 buildings to have non-fire-isolated exits provided they do not connect, pass through or pass by more than two consecutive storeys, plus an extra storey of any classification under specified conditions. The terms “connect”, “pass through” and “pass by” include the following situations:

- Where the exit provides access to the storey.
- Where the exit passes through the storey but does not necessarily provide access to or egress for the storey.
- Where the exit is external to the building, i.e. passes by the storey but does not necessarily provide access to or egress for the storey.

The allowance for two storeys is based on residents of a number of Class 3 buildings being less familiar with the building layout and paths of travel to an exit than residents of a Class 2 building. The differential between Class 2 and Class 3 buildings recognises a higher potential level of risk in Class 3 buildings.

An extra storey of any classification may be included under certain circumstances where the fire risk associated with the extra storey is low. The circumstances are:

- where the extra storey is used for a carpark or other ancillary purposes. In Class 3 buildings a carpark usually represents a low fire risk, and is unlikely to have many occupants for any length of time. The inclusion of the extra storey applies when the building only consists of a Class 3 building and a carpark. The building may also include a Class 2 part, however in such a case, the Class 3 portion of the building would control the number of storeys connected by a non-fire-isolated exit; and
- where the building contains a sprinkler system. This concession recognises the ability of sprinkler systems to extinguish or contain a fire; and
- where the exit is separated from the extra storey by walls having an FRL consistent with those required for a public corridor in a Class 2 or 3 building. By having separating walls with an FRL and by preventing any connection to the extra storey for the purpose of providing access to or egress for that storey, the non-fire-isolated exit is protected from the fire risk associated with the extra storey.

Class 9a health-care buildings—D1.3(b)(i)

Under [D1.3\(b\)\(i\)](#), required exits in Class 9a health-care buildings need to be fire-isolated if they connect, pass through or pass by more than two consecutive storeys, or the areas they connect, pass through or pass by include one or more patient care areas. The terms “connect”, “pass through” and “pass by” include the following situations:

- Where the exit provides access to the storey
- Where the exit passes through the storey but does not necessarily provide access to or egress for the storey
- Where the exit is external to the building, i.e. passes by the storey but does not necessarily provide access to or egress for the storey.

Open spectator stands—D1.3(b)(ii)

[D1.3\(b\)\(ii\)](#) allows an exemption for open spectator stands because of their open nature, which means that the build up of smoke is unlikely.

Class 5–9 buildings containing sprinklers—D1.3(b)(iii)

[D1.3\(b\)\(iii\)](#) does not apply to:

- a Class 9a building;
- a Class 9c building; or
- an open spectator stand.

[D1.3\(b\)\(iii\)](#) permits other Class 5–9 buildings to have non-fire-isolated exits provided they do not connect, pass through

Access and egress

or pass by more than two consecutive storeys, plus an extra storey of any classification under specified conditions. The terms “connect”, “pass through” and “pass by” include the following situations:

- Where the exit provides access to the storey.
- Where the exit passes through the storey but does not necessarily provide access to or egress for the storey.
- Where the exit is external to the building, i.e. passes by the storey but does not necessarily provide access to or egress for the storey.

An extra storey of any classification may be included under certain circumstances where the fire risk associated with the extra storey is low. The circumstances are:

- where the building contains a sprinkler system. This concession recognises the ability of sprinkler systems to extinguish or contain a fire; and
- where the exit is separated from the extra storey by walls having an FRL consistent with those required for a public corridor in a Class 2 or 3 building. By having separating walls with an FRL and by preventing any connection to the extra storey for the purpose of providing access to or egress for that storey, the non-fire-isolated exit is protected from the fire risk associated with the extra storey.

D1.4 Exit travel distances

Intent

To maximise the safety of occupants by enabling them to be close enough to an exit to safely evacuate.

Travel distances

The [D1.4](#) travel distances are based on an assumption of what is considered “reasonable” distances to be travelled by occupants in reaching an exit.

Method of measurement

The travel distances specified in [D1.4](#) are measured in accordance with [D1.15](#).

Class 2 and Class 3 buildings and Class 4 parts—[D1.4\(a\)](#) and [\(b\)](#)

[D1.4\(a\)\(i\)\(A\)](#) and [\(B\)](#) require a shorter travel distance, to a single exit, for Class 2 and Class 3 buildings and Class 4 parts than is required for Class 5 to Class 9 buildings.

The distance occupants of sole-occupancy units in Class 2 and Class 3 buildings and Class 4 parts must travel to leave their unit is not part of the distance specified in [D1.4](#). Accordingly, the permitted distance of travel from the point at which the occupant leaves the unit must take account of the time needed for the occupant to reach that point from within the unit.

Distance of travel must factor in the time occupants need to wake up, become alert to their predicament, and exit in a state of confusion.

This process of becoming alert will inevitably require more time to exit. Therefore the distance of travel to an exit should be shorter.

[Figure D1.4\(1\)](#) illustrates various methods of complying with [D1.4](#) for Class 2 and Class 3 buildings.

Class 5 to Class 9 buildings—[D1.4\(c\)\(i\)](#)

[D1.4\(c\)\(i\)](#) sets out the maximum travel distance in Class 5–9 buildings. This includes Class 9c buildings, but excludes Class 9a buildings, which must comply with [D1.4\(d\)](#). (See comments on [D1.4\(d\)](#) for the reason Class 9a buildings are treated differently). The additional travel distance allowed in Class 9c buildings recognises the effectiveness of sprinkler systems that must be installed in these buildings.

The distances specified allow people to evacuate in a reasonable time, assuming that they are not asleep.

In case a fire blocks a path of travel, [D1.4\(c\)\(i\)](#) requires that alternative routes must be available within 20 metres of the starting point, unless it is possible to reach a single exit within 20 m.

The conditional reference in [D1.4\(c\)](#) to sub-clauses [\(d\)](#), [\(e\)](#) and [\(f\)](#) refers to special provisions for particular types of building.

[Figure D1.4\(2\)](#) illustrates various methods of complying with [D1.4](#) for Class 5 and Class 6 buildings.

Class 5 and Class 6 buildings—[D1.4\(c\)\(ii\)](#)

[D1.4\(c\)\(ii\)](#) provides a concession for Class 5 and Class 6 buildings served by a single exit opening onto a road or open space. The concession only applies to the storey at the level of access to a road or open space.

[D1.4\(c\)\(ii\)](#) uses the phrase “at the level of access to a road or open space”. The term “level” does not require the storey to be physically level or flush with the road or open space to obtain the concession, but simply requires that the storey is at a level from which occupants finally leave the building to reach a road or open space. The concession allows a greater

Access and egress

travel distance of 30 m in lieu of 20 m to a single exit on the basis that occupants, including customers of a shop, are:

- generally aware of their surroundings in these types of buildings which are typically small shops or offices located at or near ground level;
- familiar with the location of the exit which is typically the main entrance to the shop or office; and
- familiar with the path of travel to reach the exit thereby allowing a prompt and direct egress from the space.

Small shops and offices at or near ground level also tend to have an open plan layout thereby allowing the exit to be easily sighted to permit safe and speedy egress where the space is located in close proximity to the external ground surface such as a road or open space.

The concession is applicable to a number of cases such as to any Class 5 and 6 parts of a building located in a storey at the level of access to a road or open space even though the storey may be served by more than one exit, subject to that part otherwise complying with [D1.4\(c\)\(ii\)](#).

The concession is also available for Class 5 or 6 parts of a building containing other classifications (refer to [A1.0\(3\)\(a\)](#)).

The conditional reference in [D1.4\(c\)](#) to sub-clauses [\(d\)](#), [\(e\)](#) and [\(f\)](#) refers to special provisions for particular types of building.

Patient care areas—[D1.4\(d\)](#)

Patient care areas in Class 9a buildings can present particular problems in case of emergency egress. Such areas are likely to be occupied by people who are either fully or partly non-ambulatory, and in many cases confused or incapacitated by drugs and medical and post-operative conditions.

Accordingly, the allowable distance of travel to an exit in the patient care areas of a Class 9a building is less than for Class 5–8 buildings, non-patient care areas of Class 9a buildings, and Class 9b buildings.

[D1.4\(d\)](#) should be read in conjunction with [C2.5](#).

Access and egress

Figure D1.4(1) Distances to exits in Class 2 and Class 3 buildings

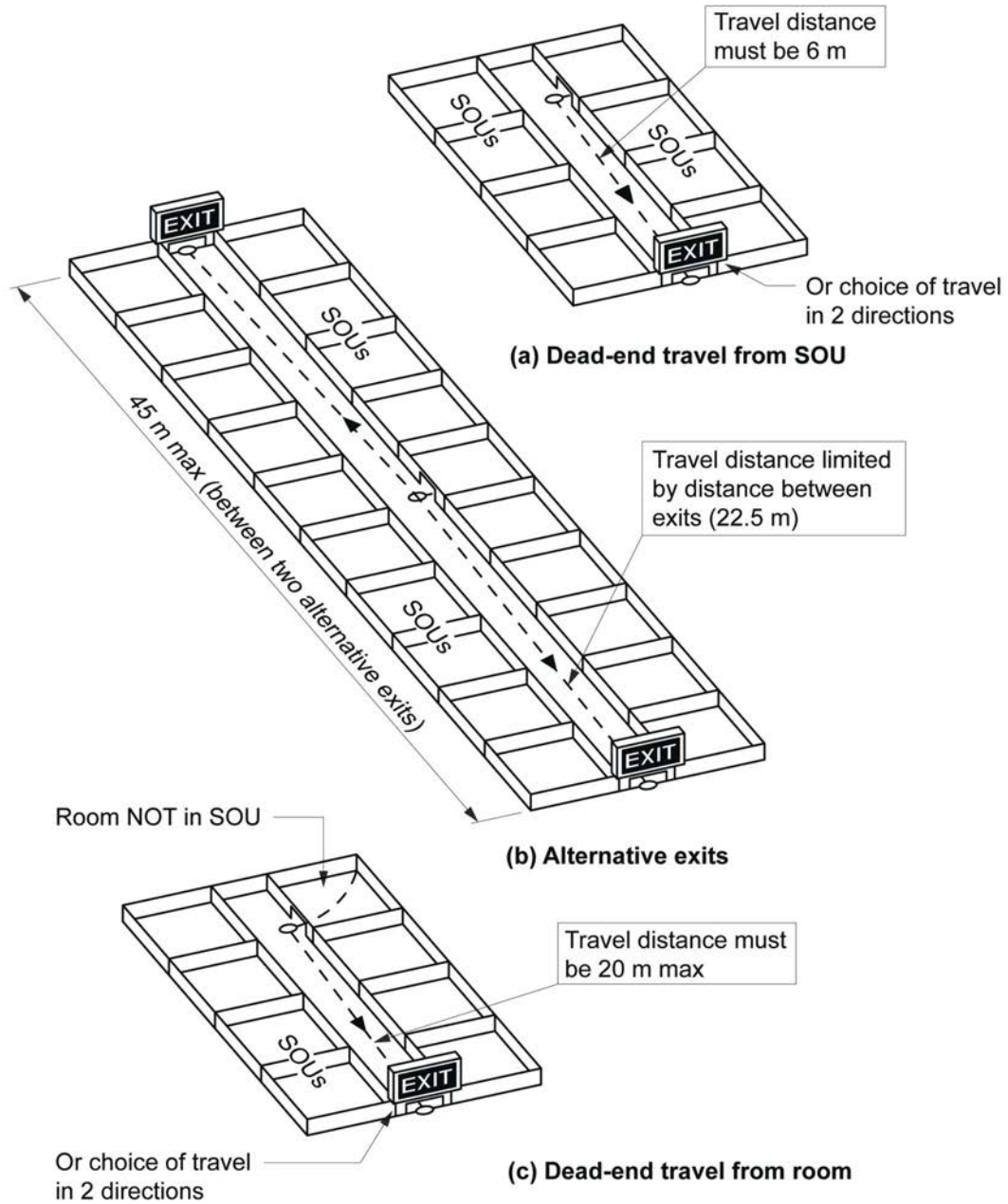

Access and egress

Figure D1.4(2) Distance to exits in Class 5 to Class 9 buildings

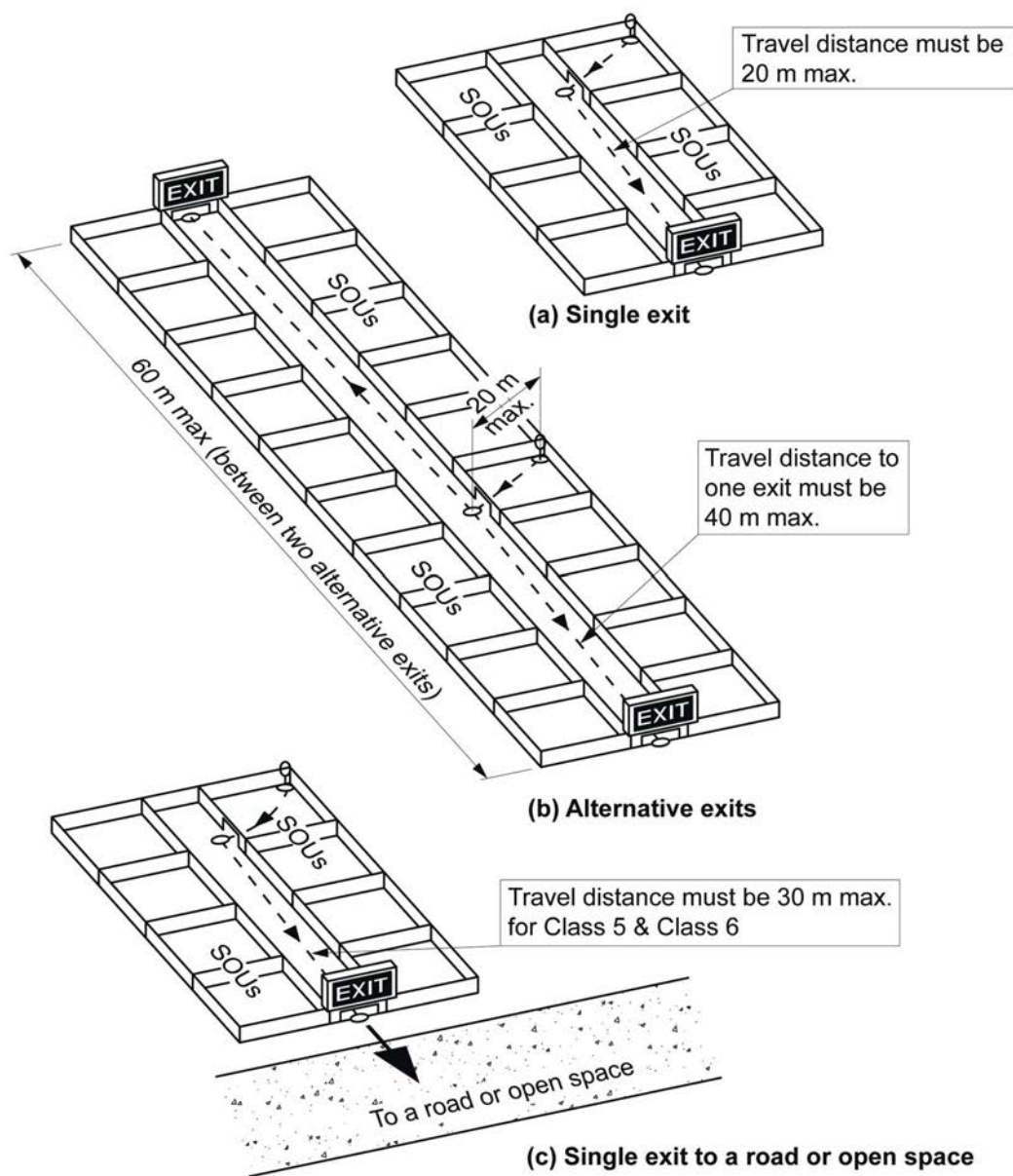

Open spectator stands—D1.4(e)

The construction of an open spectator stand is such that the build up of smoke is unlikely. Greater distances of travel to an exit are therefore permitted.

Assembly buildings—D1.4(f)

The concession available for assembly buildings is based on a specific level of fire and smoke separation being provided between the area being evacuated and the circulation space passed through to reach an exit.

To obtain the concession, D1.4(f)(iii) limits the distance of travel through the room being evacuated and across the circulation space outside that room to the exit.

D1.5 Distance between alternative exits

Intent
To require that if an exit is inaccessible, access to any required alternative exit must be available within a reasonable distance.

Why is this matter regulated?

Where a building requires multiple exits, the exits maximise the choices of a person evacuating, in case one exit becomes

blocked.

Uniform distribution of exits—D1.5(a)

D1.5(a) requires that where multiple exits exist, they must be distributed as uniformly as practicable to improve the level of safety when evacuating.

Minimum and maximum distances are set

D1.5 specifies the minimum and maximum permitted distances between alternative exits (for example, two exits may be located next to one another, so long as they are not each other's alternative in an emergency). Where scissor stairs are used, the shafts will be adjacent and separated by fire-resisting construction. However, the access doors to the alternative scissor stairs must comply with the minimum separation distance.

Minimum distance—D1.5(b)

The minimum distance minimises the risk of fire spreading to block the alternative exit.

Maximum distance—D1.5(c)

The maximum distance between alternative exits minimises the need to travel too far to reach an exit.

Convergence distance—D1.5(d)

If alternative paths of travel converge too closely, both paths can be blocked by the same fire. The minimum distance between the paths of travel aims to negate this.

The minimum convergence distance only comes into operation when the paths of travel have already diverged to that distance. The paths can commence more closely together than the distance specified.

Method of measurement

The travel distances specified in D1.5 are measured in accordance with D1.15.

Figure D1.5(1) illustrates the method of measuring the maximum and minimum distances between exits.

Access and egress

Figure D1.5(1) Plan showing method of measuring between exits

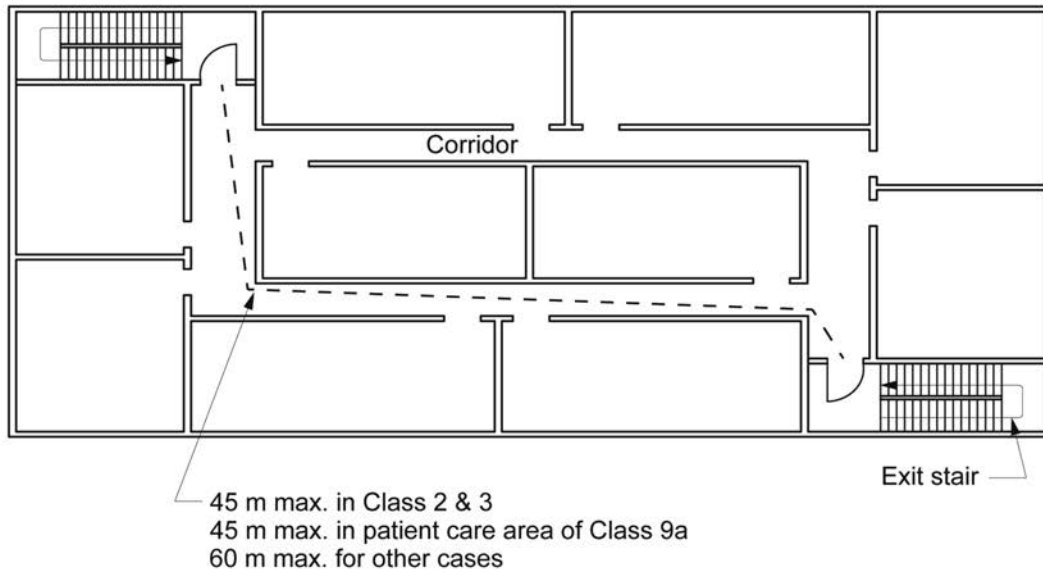

(a) Maximum separation

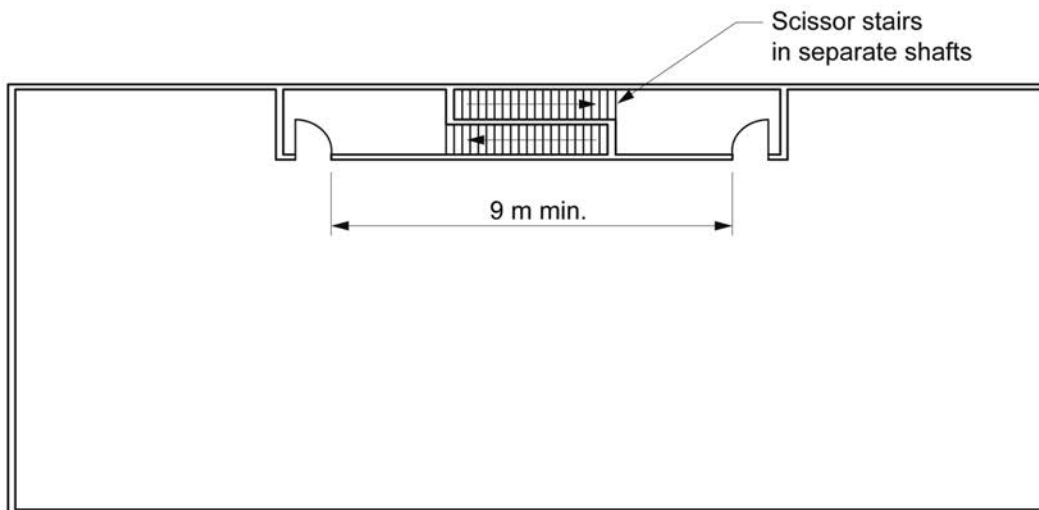

(b) Minimum separation

Figure D1.5(2) illustrates the convergence prohibition on alternative paths of travel.

Figure D1.5(2) Plan showing converging paths of travel

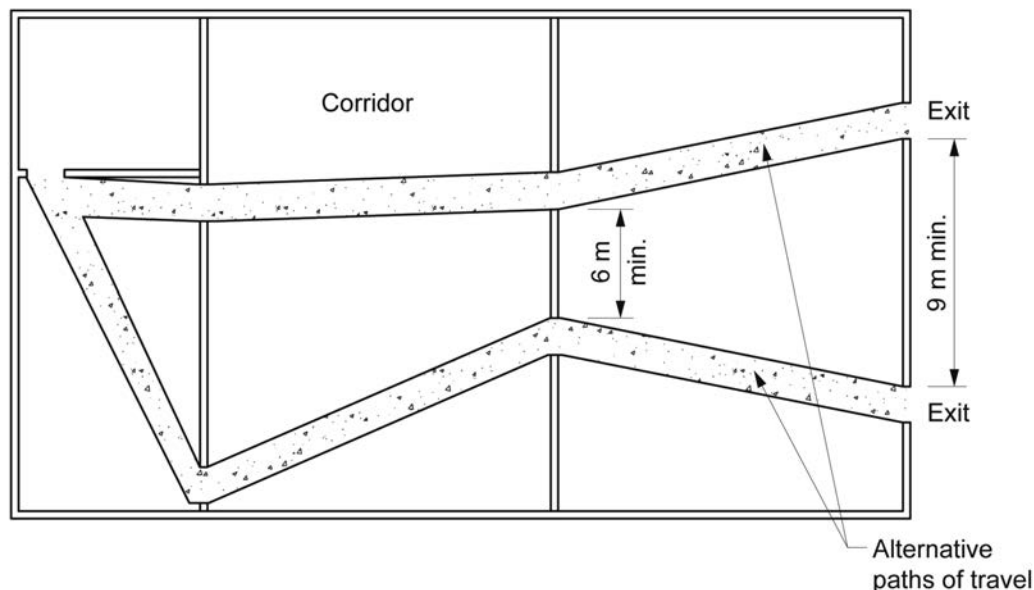

D1.6 Dimensions of exits and paths of travel to exits

Intent

To require exits and paths of travel to an exit to have dimensions to allow all occupants to evacuate safely within a reasonable time.

Height of exits and paths of travel—D1.6(a)

The D1.6(a) requirement for a minimum unobstructed height of two metres is considered to be a reasonable minimum for most people to safely walk through to gain egress.

D1.6(a) relates to the unobstructed height between a floor and:

- a ceiling; or
- a projection from a ceiling, such as a bulkhead, beam, cable tray, light fitting, pipe, sprinkler head or the like.

It should be noted that in addition to complying with D1.6, exits and paths of travel to exits must comply with the minimum ceiling heights in F3.1.

The reduction to a minimum of 1980 mm for doorways is to allow for a standard door frame.

Exit and path of travel widths

Width required to allow safe exit

The required exit and path of travel widths have been determined on the basis of an estimate of the width required to allow the safe exit of a given number of people expected in particular buildings.

Minimum unobstructed width

Exit and path of travel width—D1.6(b)

D1.6(b) clarifies that the unobstructed width of any exit or path of travel to an exit is to not be less than the dimensions prescribed. These may then be added to achieve the aggregate width that is required.

D1.6(b)(iii) applies to Class 9c buildings. The additional width at doorways is to allow for greater manoeuvrability of beds, mobile baths, wheelchairs, walking frames and other equipment throughout the resident use areas.

Figure D1.6(1) illustrates two examples of how compliance with the corridor width provisions in a Class 9c building may be achieved.

Figure D1.6(1) Method of measuring corridor width in a Class 9c building

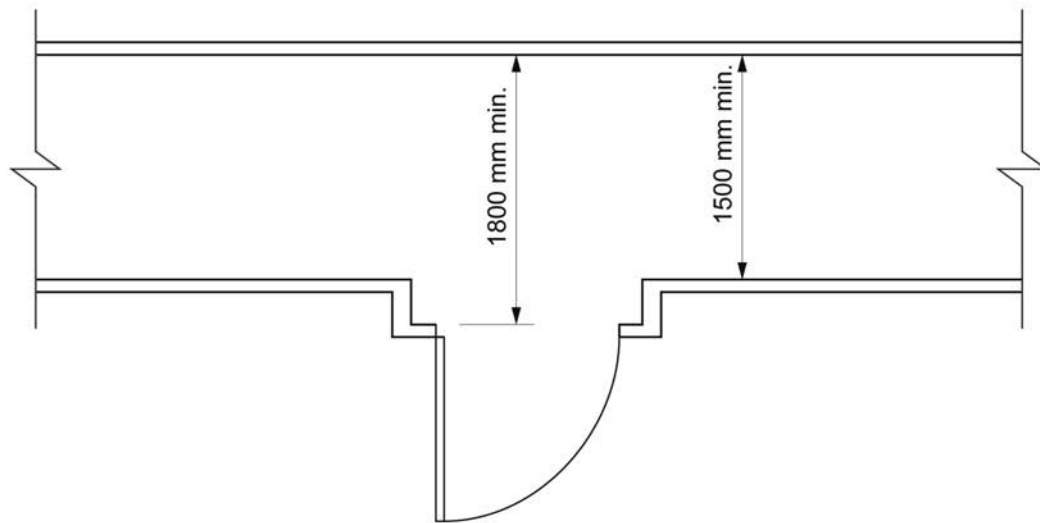

Plan View Example One

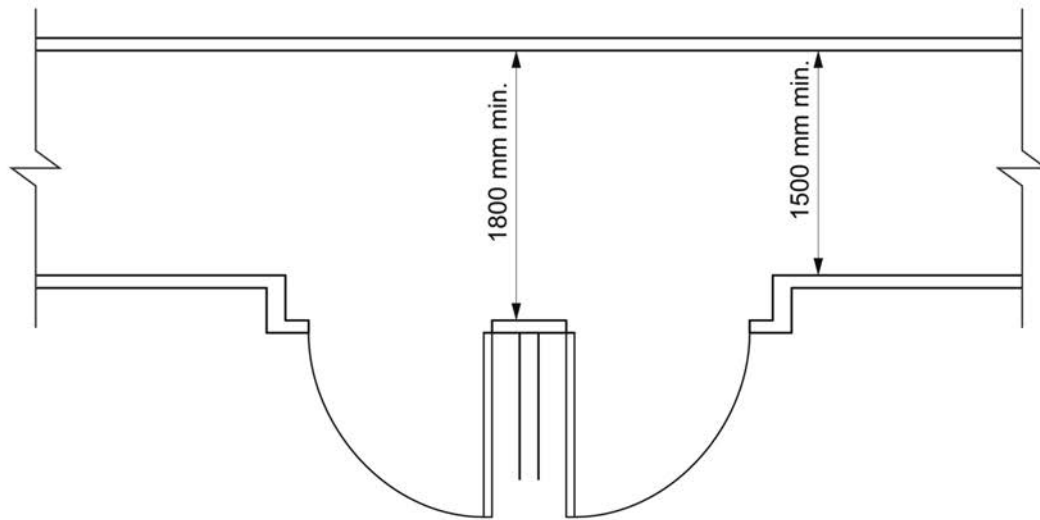

Plan View Example Two

Storeys accommodating up to 200 people—D1.6(c)

Buildings, other than ward and treatment areas of a Class 9a building, accommodating up to 200 people (see D1.6(b) and (c)) require minimum widths of:

- 1 metre for 0 to 100 people;
- 1.25 metres for 101 to 125 people;
- 1.5 metres for 126 to 150 people;
- 1.75 metres for 151 to 175 people; and
- 2 metres for 176 to 200 people.

See Figure D1.6(2).

Storeys accommodating more than 200 people—D1.6(d)

Above 200 people (see D1.6(d)), there is a division between those buildings which have a change of floor level by way of stairways or ramps with a gradient greater than 1 in 12, and those which do not have such a change in floor level. The reason for this differentiation is that the change in floor level has the potential to create problems at exits, which could cause injuries and delays. The difference can be outlined as follows, and is illustrated in Figure D1.6(2):

- Change in floor level by stairway or ramp greater than 1:12—D1.6(d)(i)

Access and egress

- 2.5 metres for 201 to 260 people;
- 3 metres for 261 to 320 people;
- 3.5 metres for 321 to 380 people;
- and so on.
- Every other case—[D1.6\(d\)\(ii\)](#)
 - 2.5 metres for 201 to 275 people;
 - 3 metres for 276 to 350 people;
 - 3.5 metres for 351 to 425 people;
 - and so on.

Aggregate width of exit or path of travel—[D1.6\(c\)](#), [\(d\)](#) and [\(e\)](#)

[D1.6\(c\)](#), [\(d\)](#) and [\(e\)](#) refer to the required width of an exit or path of travel to an exit in terms of an “aggregate unobstructed width”. The exit or path may be less than the total required width (although each must achieve the minimum required width), but when the width of each exit or path is added together, the specified aggregate unobstructed width must be achieved.

Figure D1.6(2) Graph showing required exit widths

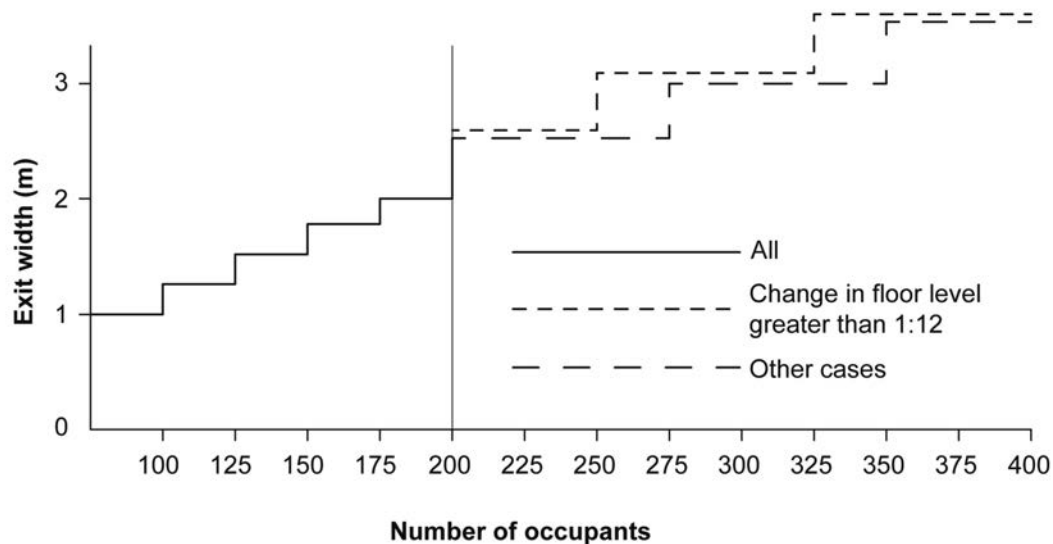
**Doorway widths—[D1.6\(f\)](#)**

The width of a doorway must be clear of all obstructions. This includes door handles or other attachments or any part of the door leaf and any part of the door frame, including the door stop.

Patient care areas—[D1.6\(f\)\(i\)](#) and [\(ii\)](#)

[D1.6\(f\)\(i\)](#) and [\(ii\)](#) provide additional width for doorways in patient care areas to allow for the turning circle of beds, and other egress difficulties, such as those experienced by patients who require ambulatory assistance.

Width of a doorway—[D1.6\(f\)\(iii\)](#)

The width of a doorway comprising part of the exit or path of travel is permitted to be 250 mm less than the width of each exit. This allows for the installation of a standard door frame.

In the case of an exit comprising multiple doorways, this concession may be applied to each individual doorway.

[Figure D1.6\(3\)](#) shows alternative examples of the exit door width for a building requiring a total exit width of three metres.

Aged care buildings—[D1.6\(f\)\(iv\)](#)

[D1.6\(f\)\(iv\)](#) applies to Class 9c buildings. The additional width of doorways is to allow for greater manoeuvrability of beds, mobile baths, wheelchairs, walking frames and other equipment throughout resident use areas.

Minimum permitted width of a doorway—[D1.6\(f\)\(v\)](#)

No doorway should be less than 750 mm in width, except doorways which open into toilets and bathrooms. However, minimum width requirements do apply to doorways which provide access to facilities required for people with disabilities (see [D3.2](#) and [F2.4](#)).

Access and egress

Exceptions to the exit and path of travel width**Treatment areas, ward areas—D1.6(b)(ii) and (c)(ii)**

D1.6(b)(ii) and (c)(ii) specify additional width requirements for the exit and path of travel to allow for the turning circle of beds.

Open spectator stand—D1.6(e)

D1.6(e) provides an exception for large open spectator stands to the exit and path of travel width required for other buildings.

Figure D1.6(3) Plan showing examples of exit widths for a building requiring an exit width of 3 m

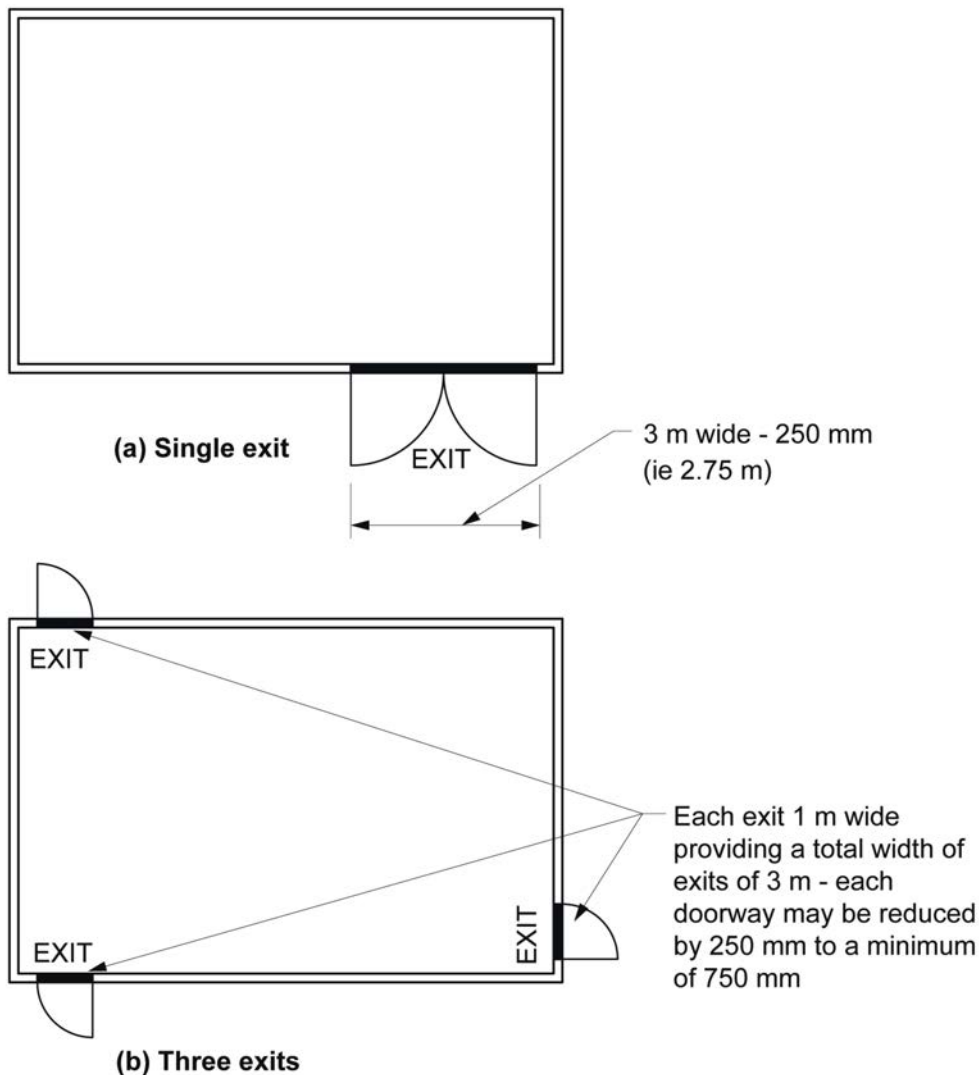
**Exit or path of travel width must not be reduced—D1.6(g)**

Under D1.6(g), the required unobstructed width of exit or path of travel must not be reduced in the direction of egress. This provision aims to avoid congestion in an exit or a path of travel to an exit.

Example

A restaurant is located on the fifth floor of a building.

The restaurant may seat 250 people. This would require an aggregate exit width of 2.5 metres. One stairway, 2.5 metres in width, is provided to achieve the exit requirement.

The fourth floor of the same building may be used as an office, with 100 staff, requiring an aggregate exit width of only 1 metre.

The 2.5 metre wide stairway from the fifth floor cannot be reduced to 1 metre when it reaches the fourth floor. The

Access and egress

stairway must retain its 2.5 metre width throughout its length.

The exit width is not required to increase to 3.5 metres below the 4th floor. The BCA makes the assumption that the occupants of both floors are unlikely to all be exiting through the same part of the stairway at the same time.

If the restaurant was below the office, the stairway could begin at 1 metre in width at the office, but would have to increase to 2.5 metres after it passed the restaurant.

Method of measurement of required width and height of stairways and ramps

Under [D1.6\(h\)\(i\)](#), the required stairway width must be measured clear of obstructions, including handrails and projecting barriers.

Example

A stairway has handrails along both sides and they are located within the width of the stairway (as opposed to along the top of a banister along the edge of the stairway).

In this case, the required stairway width must be measured between the handrails (presuming that there are no other obstructions intruding into the stairway).

Under [D1.6\(h\)\(ii\)](#), the required width of a stairway must continue to a height of 2 metres above the stair. This measurement is consistent with other similar BCA requirements.

[Figure D1.6\(4\)](#) illustrates compliance with [D1.6\(h\)](#).

Figure D1.6(4) Method of measuring height and width of a stairway

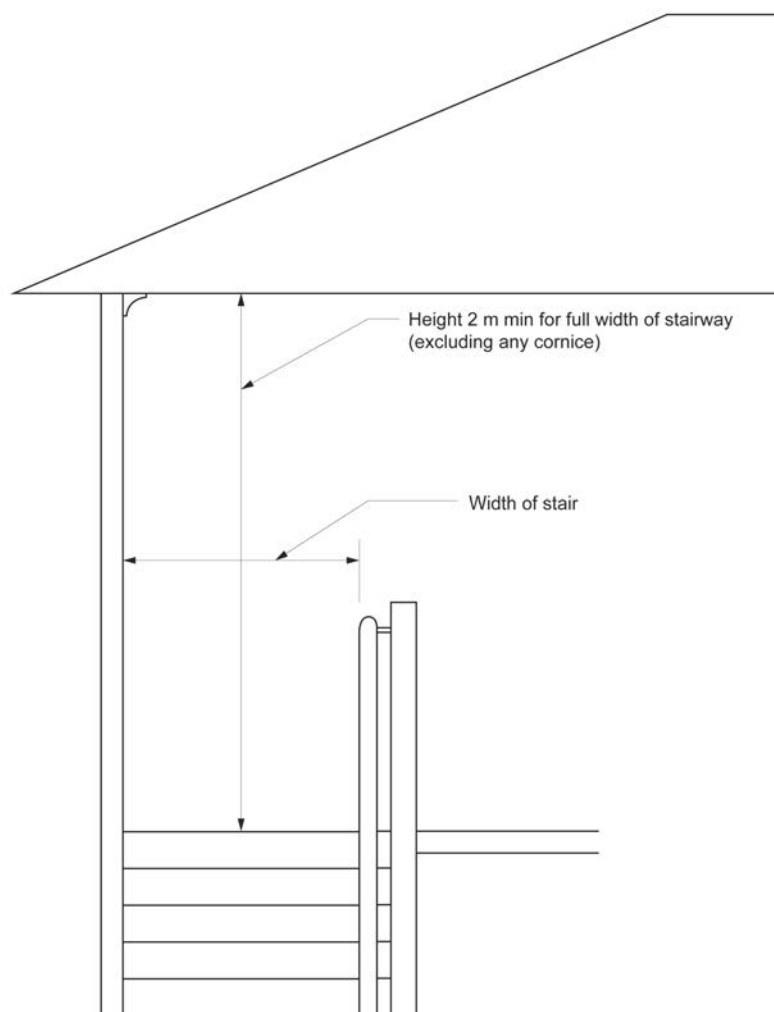

D1.7 Travel via fire-isolated exits

Intent

To enable occupants to safely enter a fire-isolated exit which discharges to a safe location.

Access to fire-isolated exits—D1.7(a)

D1.7(a) requires that a doorway must not open into a fire-isolated exit unless it opens from a public area, a sole-occupancy unit which occupies a whole floor, or a toilet. This is to limit the number of entry points into a fire-isolated exit to retain its fire-resisting performance.

Note that D1.7(a)(i) refers to a “public corridor, public lobby, or the like”. A smoke lobby which serves at least two sole-occupancy units is a “public lobby”, and can open directly into a fire-isolated exit. Figure D1.7(1) illustrates permitted and prohibited entry into a fire-isolated passageway from sole-occupancy units in a shopping centre.

Discharge to areas not roads and open spaces—D1.7(b)

D1.7(b)(i) requires fire-isolated exits to discharge to roads or open spaces. However, there are some exemptions:

- D1.7(b)(ii) sets out the requirements for a fire-isolated exit to discharge into an area within a building (including the requirement that it be open for at least two thirds of its perimeter, to aid smoke ventilation); and
- D1.7(b)(iii) sets out the requirements for a fire-isolated exit to discharge into a covered area outside the building (including the requirement that it be open for at least one third of its perimeter, to aid smoke ventilation).

Access and egress

Figure D1.7(1) Plans showing entry into a fire-isolated passageway in a shopping centre

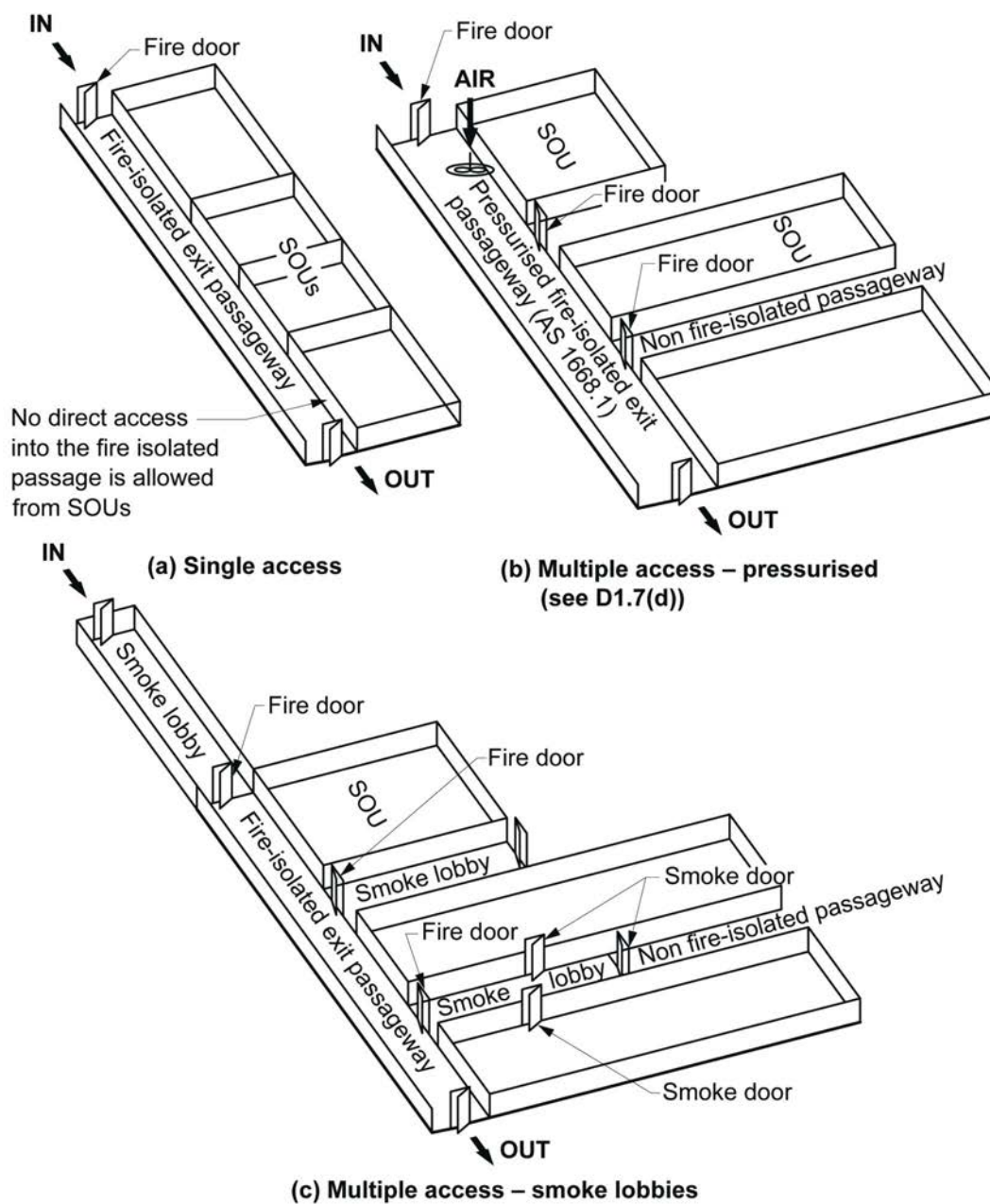

Figures D1.7(2) and (3) illustrate some of the options available by the use of D1.7.

Access and egress

Figure D1.7(2) Example of discharge of fire-isolated stair complying with D1.7(b)(ii)

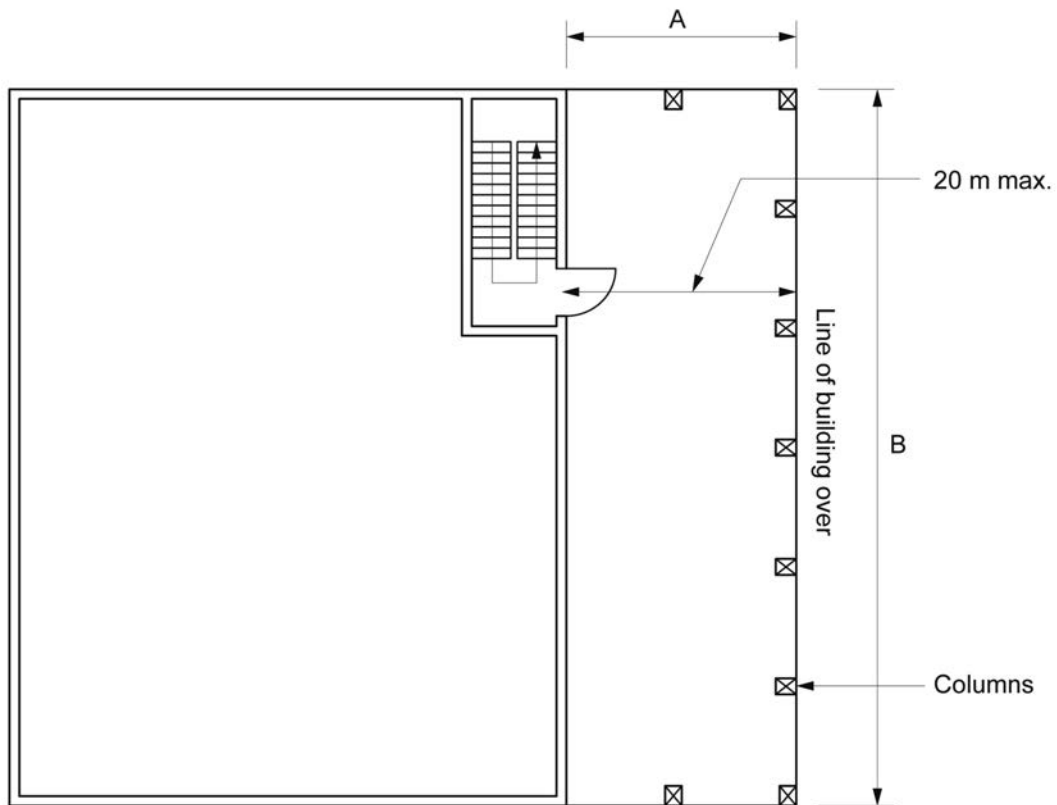

Sum of openings $W = 2A + B$ - aggregate width of columns
 This must be at least $\frac{2}{3}$ of perimeter.
 ie. $\frac{2}{3}$ of $(2A + 2B - \text{aggregate width of columns})$

Access and egress

Figure D1.7(3) Example of discharge of fire-isolated stair complying with D1.7(b)(iii)

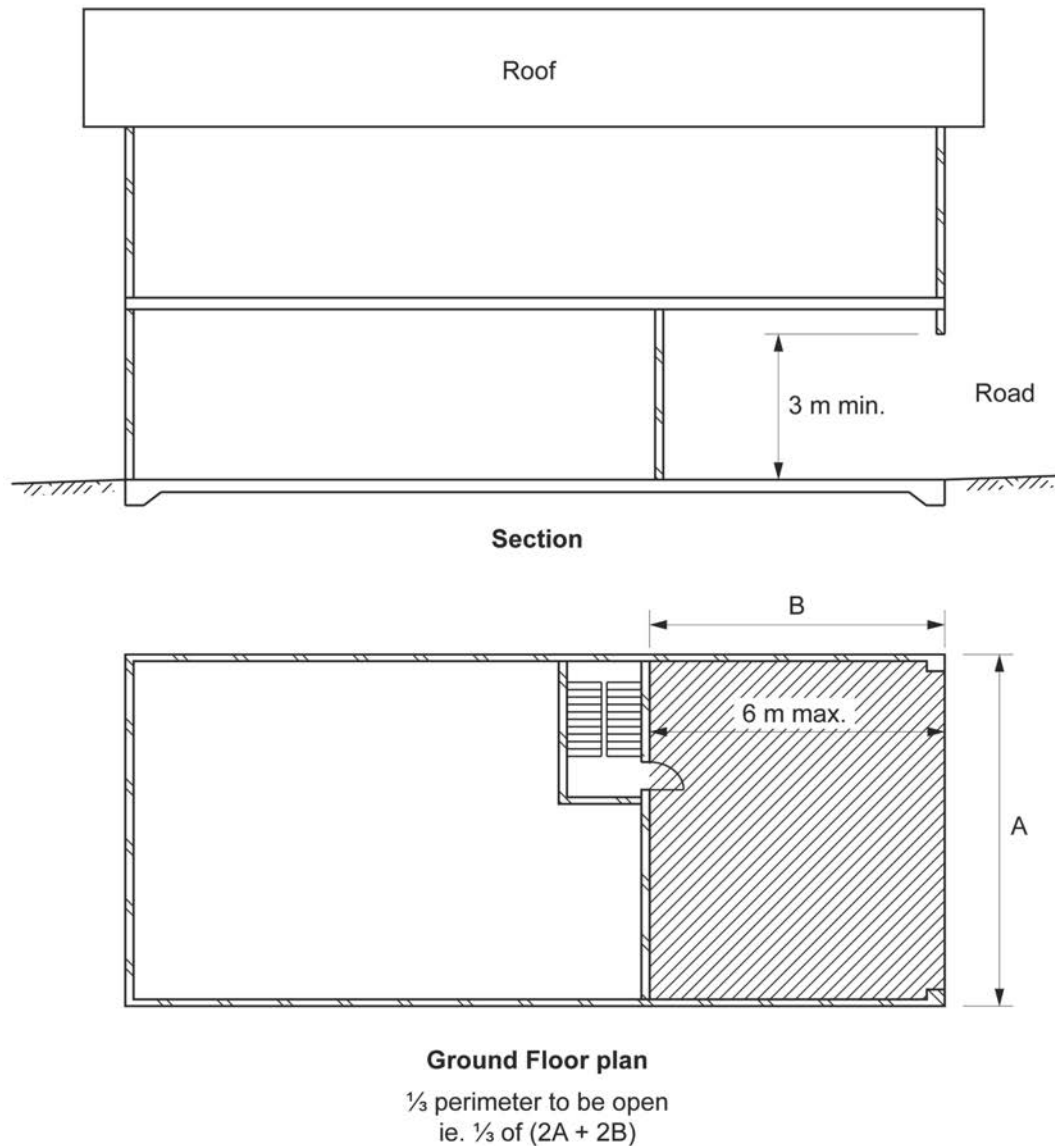
**Travel within 6 metres of an external wall—D1.7(c)**

D1.7(c) sets out the FRL and opening protection requirements where the path of travel from the point of discharge of a fire-isolated exit to a road or open space necessitates passes within six metres of any part of the external wall of the building being evacuated. The provision only applies at the level of discharge. So if the exit discharges at ground level, any first storey wall or window would not need protection. The reason is that a fire on the first floor is unlikely to affect people exiting one storey below.

Figure D1.7(4) illustrates when walls and window openings require protection in accordance with D1.7(c).

Access and egress

Figure D1.7(4) Plan showing when walls and windows require protection in accordance with D1.7(c)

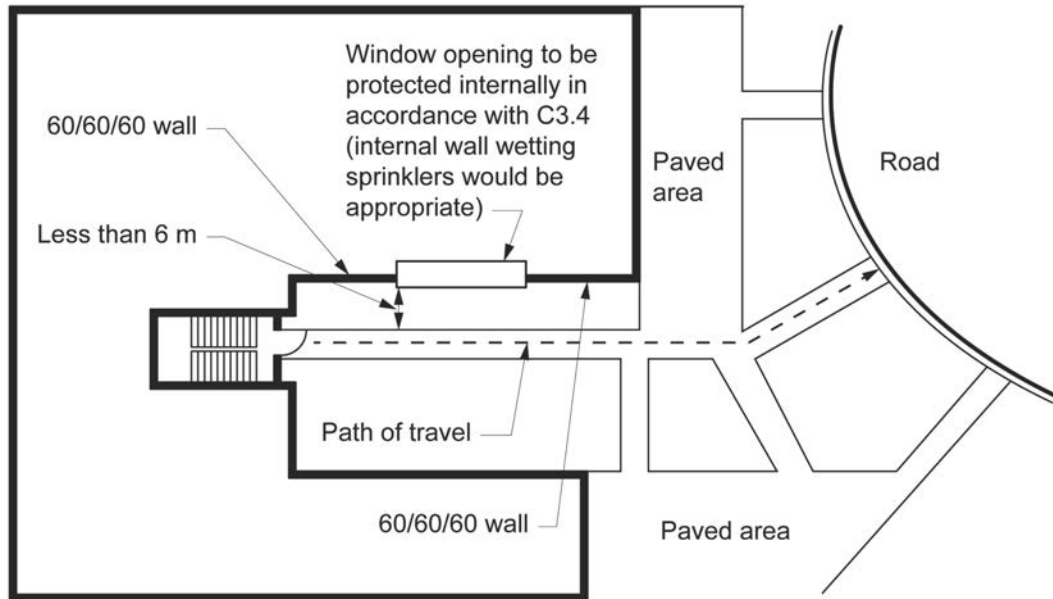
**Smoke lobby or pressurised system—D1.7(d)**

D1.7(d) requires the use of a smoke lobby or a pressurisation system to stop the entry of smoke into the fire-isolated exit, if more than two access doorways described in D1.7(a)(i) or (ii) are provided in the same storey. This provision must be read in conjunction with D1.7(a), it does not over-ride it. See Figure D1.7(1).

Ramps in Class 9 buildings—D1.7(e)

D1.7(e) requires a ramp where there is any change in level in a fire-isolated passageway in a Class 9 building and that change is less than 600 mm.

D1.8 External stairways or ramps in lieu of fire-isolated exits**Intent**

To detail the circumstances in which an external stairway or ramp can be provided instead of a fire-isolated stairway or fire-isolated ramp.

Alternative to required fire-isolated stairways or ramps

Compliance with D1.8 for external stairway or ramp is only required where the external stairway or ramp is proposed as an alternative to a required fire-isolated stairway or ramp. In other words, if a fire-isolated stairway or ramp is not required by the BCA, compliance is not required with D1.8.

External stairways and ramps permitted to 25 metres

The use of an external stairway or ramp is permitted instead of a fire-isolated stairway or ramp up to a height of 25 metres. The reason external stairways or ramps are not permitted above this height is because of:

- the risk that people would suffer vertigo above this level;
- the risk that weather conditions, particularly wind, may become more severe above this height; and
- the need to enable any person who gets into difficulties on the stairway to be rescued by way of fire brigade ladders or other rescue equipment, which generally do not reach above this height.

Fire protection required

Fire protection from the external wall of the building near the external exit and any openings in that wall, is required under D1.8(a) and (b) to ensure that an average person using the exit is afforded adequate protection from flames and radiant heat from a fire within the building.

D1.8(c) provides two separate methods of protecting the external exit from a fire from within the building:

- protect the external wall of the building and any openings in the wall, within the prescribed distances to the exit (see Figure D1.8(1)); or

Access and egress

- protect the exit by shielding construction where the exit is within the prescribed distances to the building (see Figure D1.8(2)).

Figure D1.8(1) Protection of the external exit using the external wall of the building in accordance with D1.8(c)(i)

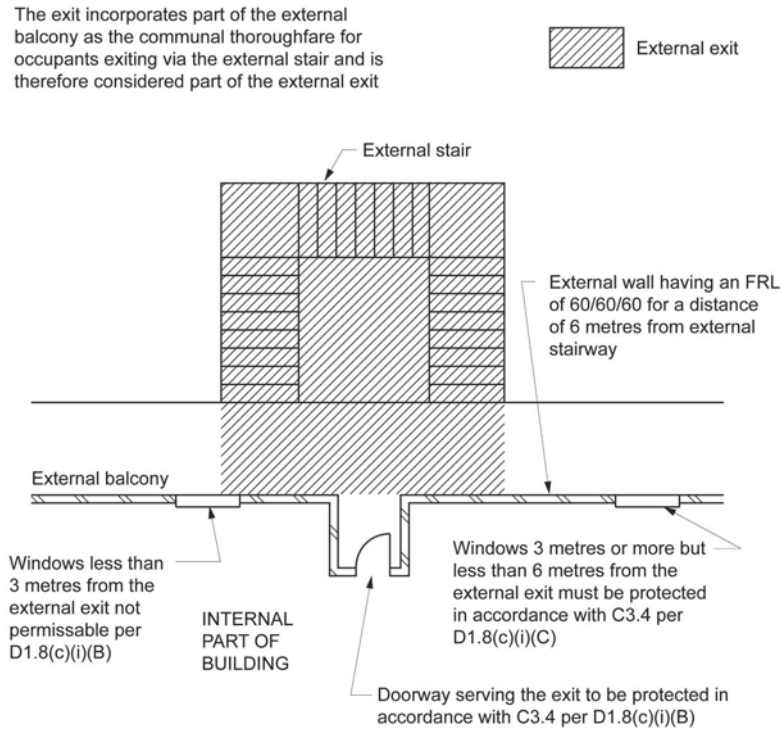

D1.8(d) provides requirements for the shielding construction and protection of any openings in that construction.

Figure D1.8(2) Protection of the external exit using shielding construction in accordance with D1.8(c)(ii)

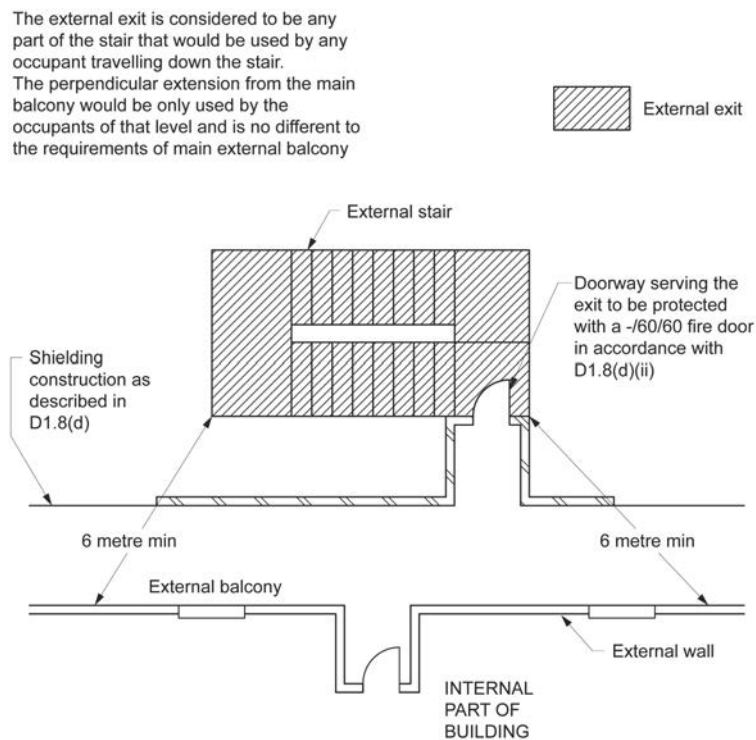

D1.9 Travel by non-fire-isolated stairways or ramps

Intent

To require that a person using a non-fire-isolated stairway or ramp be provided with a safe evacuation path.

Continuous means of travel—D1.9(a)

D1.9(a) requires that occupants in a required non-fire-isolated stairway or ramp are able to continue all the way down to the level from which egress to a road or open space is available.

D1.9(a) refers to a continuous means of travel comprising flights of stairs and landings. It would generally not be acceptable for an entire or substantial proportion of a storey to be called a “landing”.

The first diagram in Figure D1.9(1) illustrates non-compliance with D1.9(a) because the stair does not provide a continuous path of travel to the level providing egress to a road or open space. The second diagram in Figure D1.9(1) illustrates a method of compliance with D1.9(a).

Required stairways and ramps

The distances specified in D1.9 apply only to a required non-fire-isolated stairway or ramp.

Figure D1.9(2) illustrates the method of measuring a travel distance down a stairway.

Distances for non-fire-isolated stairways—D1.9(b) and (c)

D1.9(b) and (c) provide requirements for the overall travel distances permitted on non-fire-isolated stairways. Figure D1.9(3) illustrates compliance with D1.9(b) and (c).

Distance from stairway to discharge point—D1.9(d) and (e)

D1.9(d) and (e) provide requirements for the travel distance permitted from the base of the non-fire-isolated stairway to the discharge point (note that this distance is part of the distances required under D1.9(b) and (c)). Figure D1.9(4) illustrates compliance with D1.9(d) and (e).

Class 2 or Class 3 requiring 2 or more exits—D1.9(f)

D1.9(f) provides the additional requirements for Class 2 and Class 3 buildings which are required to have 2 or more exits.

Figure D1.9(5) illustrates one method of an exit system in a Class 5–9 building complying with Section D.

Access and egress

Figure D1.9(1) Section showing compliance with D1.9(a)

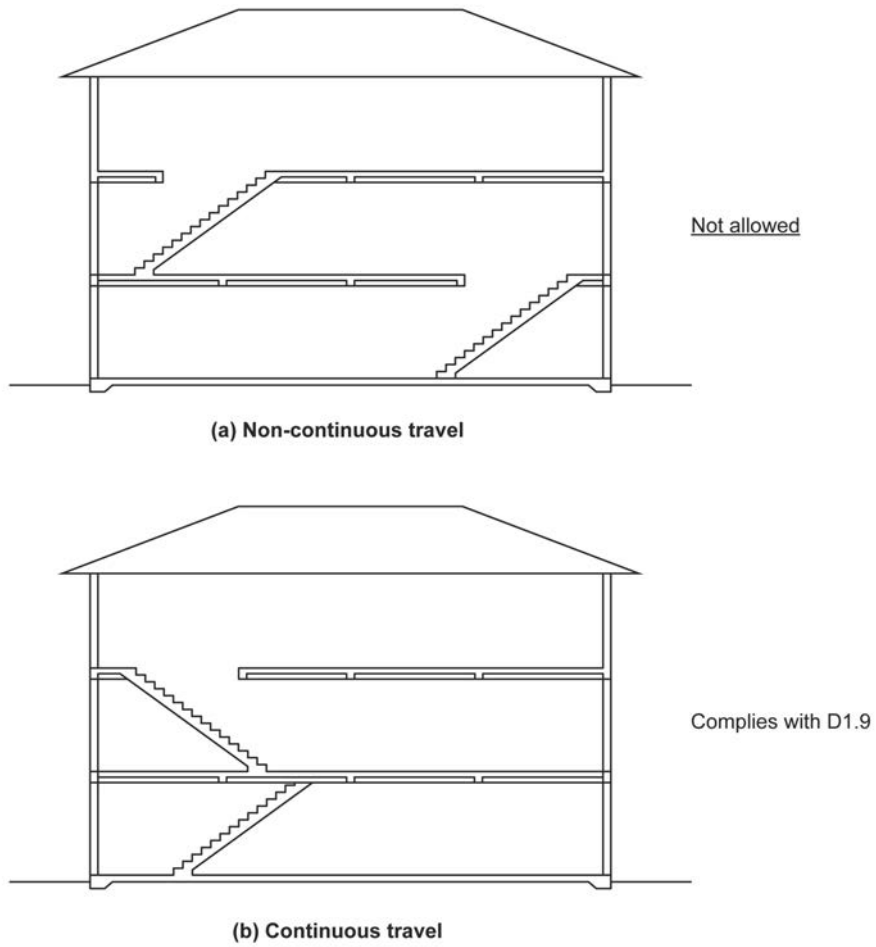
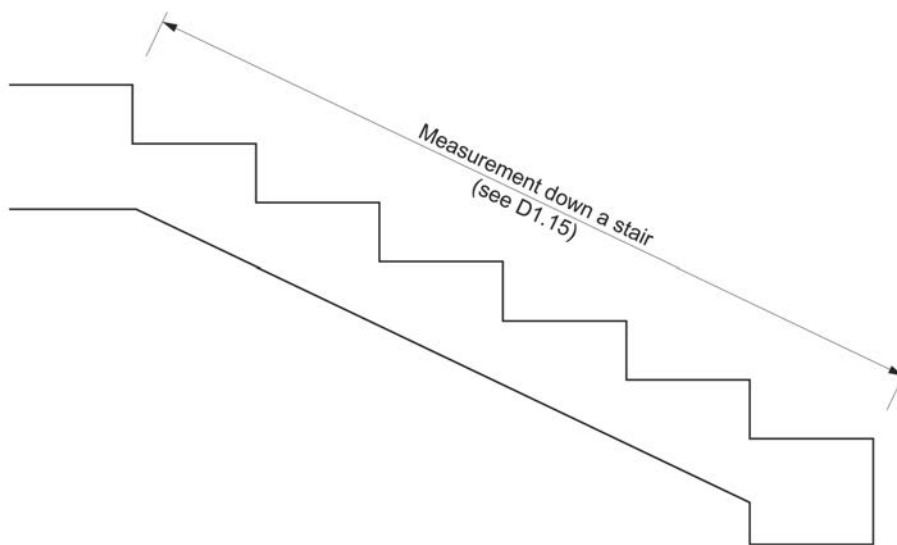
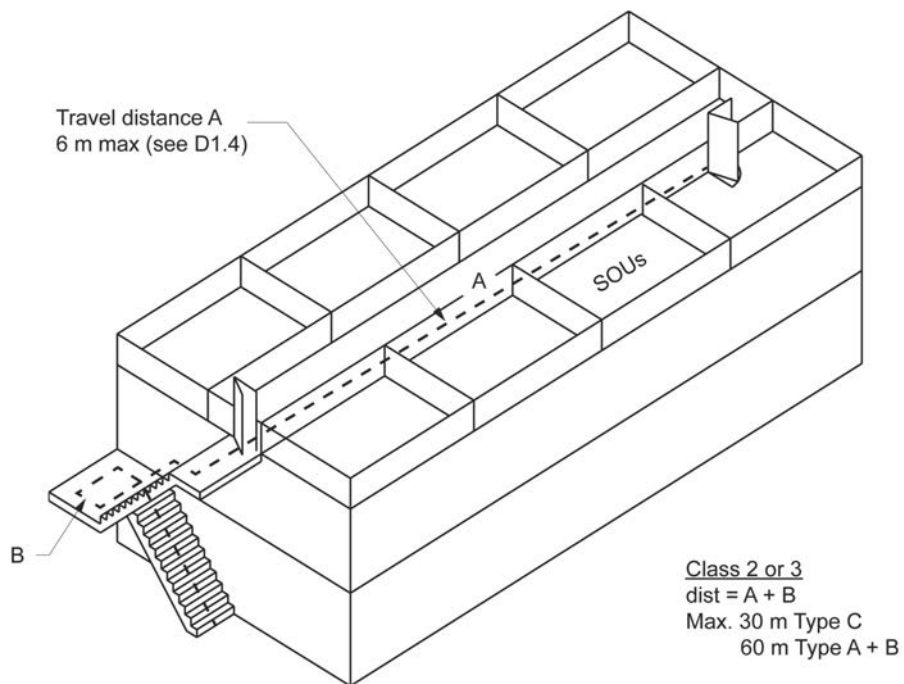

Figure D1.9(2) Method of measuring travel distance down a stairway



Access and egress

Figure D1.9(3) Method of measuring overall distance of travel via non-fire-isolated stairways



Access and egress

Figure D1.9(4) Plans showing compliance with D1.9(d) and (e) for the discharge of non-fire-isolated stairways

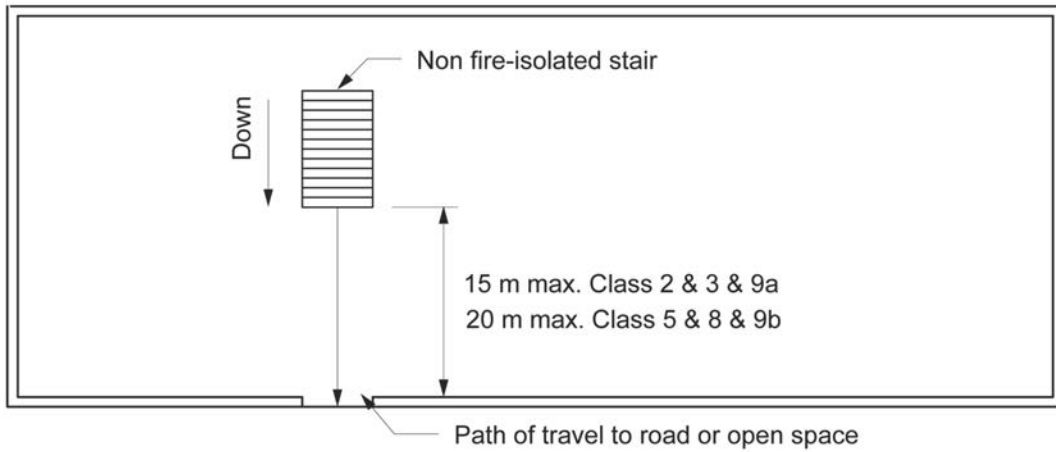

(a) Single point of egress

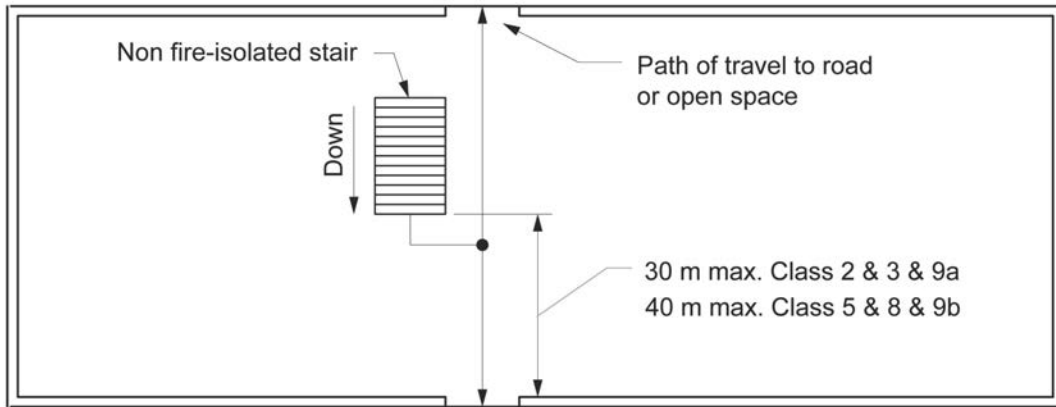

(b) Alternative points of egress

Figure D1.9(5) One method of compliance with Section D

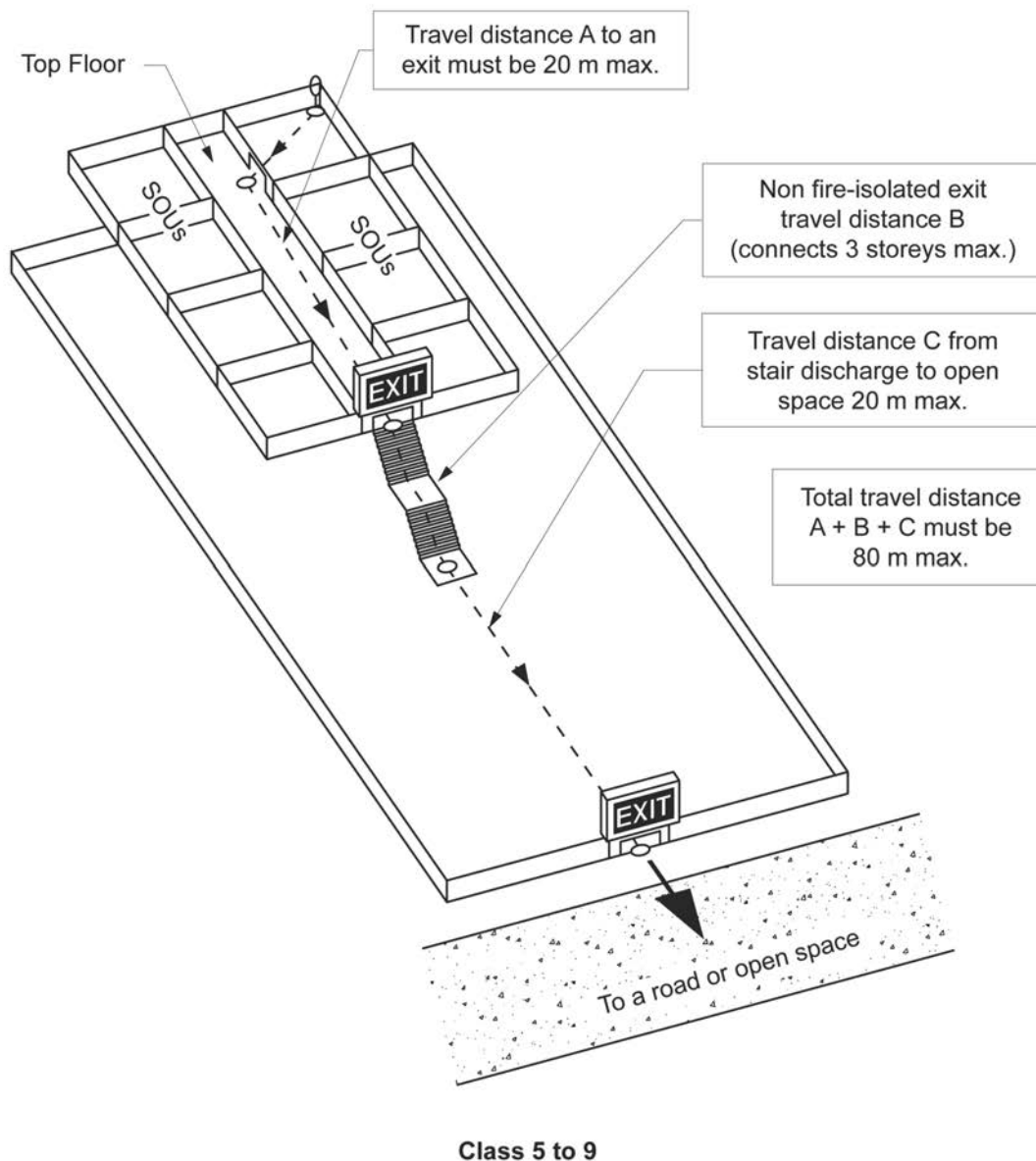

D1.10 Discharge from exits

Intent
To require the safe discharge from an exit to a road or open space.

Egress not to be blocked—D1.10(a)

D1.10(a) requires that an exit must not be blocked at the point of discharge.

Barriers (such as bollards) must be installed, if they are necessary to prevent vehicles blocking access to, or discharge from, an exit.

Link between open space and a road—D1.10(b) and (c)

If an exit discharges to an open space, D1.10(b) and (c) require that a safe means of travel be provided from the open space to a road. This means that the following criteria must be satisfied:

- **D1.10(b)**—to maximise the safety of people moving towards a road during an evacuation, the width of the path of travel from the open space to the road must be at least that required for the exit (and in no case less than one metre).
- **D1.10(c)**—to minimise the risk from falling or tripping, any stairways or ramps must comply with the rest of the

Access and egress

BCA (eg construction of treads, landings etc). This may include the provision of ramps suitable for people with disabilities.

The link between the road and open space must be open to the sky for its length.

Discharge points to be well separated—D1.10(d)

D1.10(d) requires that the discharge points of alternative exits be as far apart as possible, so that if the discharge from one of them is blocked, the other will still operate satisfactorily.

Open spectator stand—D1.10(e)

D1.10(e) requires that exits from an open spectator stand not discharge to the ground in front of the stand. There may be a large number of people viewing the event from the front of the stand, and they may obstruct the path of those evacuating.

There is also a risk that the front of the stand could be subject to severe heat radiation. Also the only egress to the road from the ground in front of the stand may be through the stand.

Auditorium—D1.10(f)

Under D1.10(f), only two thirds of the required width of exits from an auditorium, such as a theatre or hall, are to discharge into an entrance foyer where the auditorium can accommodate more than 500 people. This restriction applies because there may be a large number of people in the foyer, possibly waiting for the next show, or to gain access to another auditorium. These people would obstruct the path of the people evacuating.

D1.11 Horizontal exits

Intent

To detail how the installation of horizontal exits in a building is permitted as an alternative to a conventional exit.

Difficult evacuations

Originally, provision was made for horizontal exits between fire compartments because some occupants can have difficulty evacuating, particularly those confined to bed or that have a disability.

Subsequently, it was accepted that horizontal exits would be of value in other buildings, where they could overcome problems associated with large fire compartments, eg excessive distances to travel to exits.

Purpose of horizontal exits

The use of horizontal exits can overcome some of the difficulties outlined above, although they need to be used in conjunction with some other form of exit.

In an emergency, the Deemed-to-Satisfy Provisions require that occupants travel for limited distances before they reach a place of safety. A “place of safety”, in the case of horizontal exits, means the connecting fire compartment to which people will flee.

For a horizontal exit to comply with the Deemed-to-Satisfy Provisions of Section D, it must meet the following criteria:

- The distance of travel to the exit must not exceed that specified elsewhere in the BCA.
- The protection for a place of safety from its adjoining fire compartment is provided by a fire wall. The fire wall has a fire rating to match the classification of the fire compartments it divides and is expected to withstand a burnout of the respective areas. This provides an appropriate level of safety to people using the horizontal exit as they may have to remain in the place of safety for an extended period before evacuating via other exits.
- There must be another exit (other than a horizontal exit) from each place of safety entered by way of a horizontal exit. After escaping to the place of safety it should not be necessary to return to the area being evacuated to continue to evacuate from the building. D1.11(c) specifies a limit for the number of horizontal exits in a storey for buildings of other than Class 9a and Class 9c buildings.
- The place of safety must be large enough to temporarily accommodate the people from the area the horizontal exit is being provided for. It is important to note that if there is only one other exit in the fire compartment then the place of safety is to be large enough to accommodate all the occupants of the fire compartment. This is necessary because if the other exit is blocked then all the occupants will be required to exit through the horizontal exit. This is necessary until vertical evacuation is available. Since this accommodation is only for a short period, the areas specified generally only allow for people to stand. However, the larger areas specified for Class 9a health-care buildings and Class 9c buildings allows for patients or residents on beds to be wheeled through the horizontal exit to be accommodated in the place of safety.
- The path to the place of safety is to have dimensions equal to those of the horizontal exit to assist with the smooth evacuation of occupants.
- The swing of the horizontal exit door must be the same as other exit doors. This means that if the area is more than 200 m² (as specified in D2.20(b)), the door is to swing in the direction of egress. If the FRL of the fire wall

Access and egress

is three or four hours, two fire doors may be provided to achieve this FRL. In such cases, for both doors to swing in the one direction, a vestibule must be formed, as shown in Figure D1.11.

- To make sure that evacuation is always possible, it is not permitted to have a horizontal exit to a separate sole-occupancy unit. This is because the owner or occupier of the other unit may lock the door for security reasons, barring entry (or exit) in an emergency.
- Where egress is required in either direction, two doors swinging in opposite directions or a 180° swinging door (complying with all BCA requirements including fire and smoke sealing capacities) may be used.

Other uses of horizontal exits

Horizontal exits may be useful as a means of evacuation from many health-care buildings. They can also be an advantage in large floor area buildings which need to be sub-divided by fire walls to reduce the size of the fire compartments. These fire walls can then be penetrated to create horizontal exits.

Figure D1.11 Plan showing doors forming a horizontal exit in a fire wall in accordance with D1.11

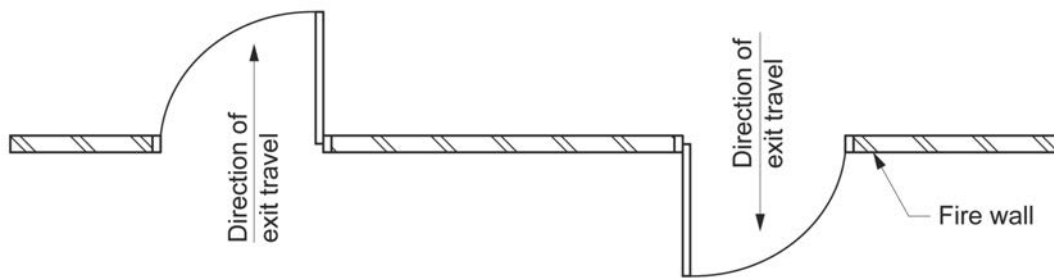

(a) Travel in both directions

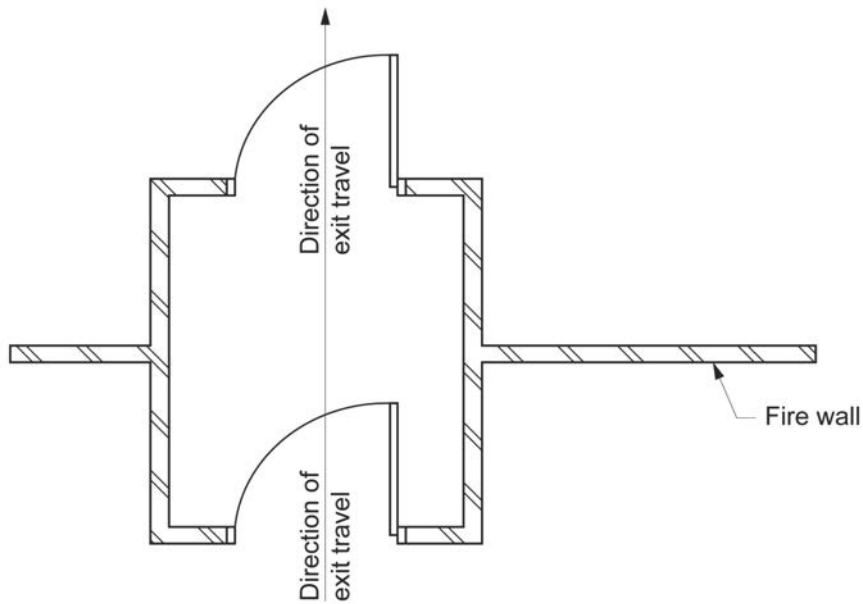

Class 7 or 8 building (Use of 2 doors)

(b) Travel in one direction

D1.12 Non-required stairways, ramps or escalators

Intent

To limit the spread of fire and smoke through unprotected openings for stairways, ramps, escalators and moving walkways.

Application

D1.12 only applies to:

Access and egress

- escalators;
- moving walkways and travelators;
- non-required non-fire-isolated stairways; and
- non-required non-fire-isolated ramps.

What is a non-required non-fire-isolated stairway or ramp?

Builders etc may choose to interconnect two or three storeys of a building with a non-required stairway, ramp or the like in accordance with [D1.12](#).

Example

A two storey shop or suite of offices may be within a multi-storey building where all storeys are connected by a stairway which is both required and fire-isolated. This stairway may be external to the sole-occupancy unit which comprises the shop or office suite. For easy access within the sole-occupancy unit, another stairway may be located within the shop or office suite interconnecting the two storeys. That stairway is additional to the required stairway, and is not required to be fire-isolated.

Patient care and resident use area—D1.12(a)

[D1.12\(a\)](#) prohibits the use of a non-required non-fire-isolated stairway or ramp in a patient care area of a Class 9a building and a resident use area of a Class 9c building. The prohibition is because of the difficulties in evacuating bed-ridden, or otherwise mobility-impaired occupants. This prohibition applies to [D1.12\(d\)](#), despite that provision's general reference to Class 9 buildings.

[D1.12\(b\)](#) allows any number of storeys to be connected in certain buildings as follows:

- The open nature of the construction of an open spectator stand, sports stadium, carpark, atrium, and a stairway or ramp located outside a building is such that the build-up of smoke is unlikely. [D1.12\(b\)\(i\)](#), [\(ii\)](#) and [\(iii\)](#) permit any number of interconnected floors in such cases.
- In a Class 5 or Class 6 building containing a sprinkler system, [D1.12\(b\)\(iv\)](#) allows connection of any number of storeys if the interconnecting stairway, ramp, or escalator and the like complies with [Specification D1.12](#).

Atriums and Part G3—D1.12(b)(ii)

- While [D1.12\(b\)\(ii\)](#) refers to atriums, there are additional requirements for atriums in [Part G3](#).

Number of interconnected storeys is restricted—D1.12(c) and (d)

[D1.12](#) restricts the number of storeys which can be interconnected by a non-required non-fire-isolated stairway, ramp or the like. This recognises that an unprotected opening for a stairway, ramp, escalator or the like can lead to the spread of fire or smoke from one floor to another.

The restriction applies if:

- [D1.12\(c\)\(i\)](#)—a Class 2–9b building (excluding Class 9a) contains a sprinkler system, no more than three consecutive storeys can be linked, one of which storeys must directly egress to a road or open space. This recognises the effectiveness of a sprinkler system in controlling the spread of fire;
- [D1.12\(c\)\(ii\)](#)—the building is an unsprinklered Class 2 or Class 3 building, two consecutive storeys can be linked, one of which must directly egress to a road or open space. [Part D1](#) does not generally apply to sole-occupancy units in Class 2 or Class 3 buildings, or Class 4 parts, and there is no restriction on an internal non-required non-fire-isolated stairway, ramp or the like linking two storeys in, for example, a two storey penthouse suite; or
- [D1.12\(d\)](#)—in a Class 5 or Class 6 building which does not qualify under [D1.12\(b\)\(iv\)](#), and in Class 7–9b buildings (excluding a patient care area in a Class 9a, see [D1.12\(a\)](#)), two consecutive storeys can be linked.

Neither storey is required to provide direct egress to a road or open space and there is no requirement for a sprinkler system as part of this provision. As the stairway or ramp is not required by the BCA for emergency evacuation purposes, this provision is in accord with the remainder of the BCA.

D1.13 Number of persons accommodated**Intent**

To establish a methodology for calculating Deemed-to-Satisfy building populations which are deemed acceptable for use in the design and checking of applications when more accurate figures are not available.

[D1.13](#) and [Table D1.13](#) are used to calculate the anticipated number of people in particular types of building.

From these calculations, a number of BCA requirements can be determined within [Sections D, E, F](#) and [J](#). The likely number of persons accommodated can affect determinations in relation to a number of matters in the BCA including: exit

Access and egress

requirements, hearing augmentation, limitation of the use of stairway platform lifts, sanitary facilities, ceiling heights and the energy efficiency of mechanical ventilation systems.

D1.13 not to be used for non-BCA purposes

D1.13 and Table D1.13 are only intended for the purposes of determining BCA requirements which depend on the number of occupants likely to occupy a building or storey. D1.13 and Table D1.13 are not intended to restrict the number of occupants using a building, or to enforce any building use or licensing requirements.

Use of Table D1.13

If more accurate information is available on the expected population of a building, it should be used in preference to Table D1.13. This information may include:

- D1.13(b)—if the building is an assembly building or room, its seating capacity can be used; or
- D1.13(c)—where there is limited public access, a statement from the building owner as to the number of occupants who will use the building; or
- D1.13(c)—a study of the number of people using similar buildings. Such a study must include the number of people at various times. As an example, if the building is to be used as a shop, the figures must include the maximum numbers of people expected at peak times (such as before Christmas).

Example

It would be appropriate to use an alternative means of assessing the number of occupants when:

- under D1.13, a restaurant is deemed to accommodate one person for every square metre of floor area;
- if a specific restaurant has fixed tables, booths, dining alcoves and architectural features which occupy significant floor space, the actual number of patrons able to be accommodated may be much less than the number calculated using D1.13; and
- in such a case, it may be appropriate to use another method for calculating the number of people accommodated (such as counting the number of seats available for use by patrons), and hence calculating the total width of exits to be provided; however
- if such an approach is adopted, due allowance must be made for the employees, as well as the potential for alternative seating layouts which could increase the number of people in the restaurant.

The area per person contained in Table D1.13 for computer rooms applies to rooms housing computer infrastructure such as computer servers and where low occupant numbers occur. These circumstances are similar to those found in switch or transformer rooms. For computer training rooms and office areas containing computers, the area per person for an office or school classroom, as appropriate, should be used.

D1.14 Measurement of distances**Intent**

To identify the nearest part of an exit for the purposes of measuring travel distance.

Why is this important?

D1.14 describes the point at which an exit has commenced with respect to both fire-isolated and non-fire-isolated exits. Figures D1.15(1) and D1.15(2) illustrate methods of measuring the distance of travel specified in the BCA.

D1.15 Method of measurement**Intent**

To specify the method of measuring the distance of travel to an exit in various situations.

Path a person would walk

The distance of travel to an exit is measured by determining the path a person would walk from the most remote area of the building to the nearest exit.

The maximum distance of travel between required alternative exits is measured by determining the path a person would travel along in a case where a fire blocks the path of travel to the nearest exit. The path of travel to the alternative exit includes passing through the point at which travel in different directions to those exits is available.

Access and egress

Figure D1.15(1) Plan showing measurement of maximum distance of travel between required alternative exits

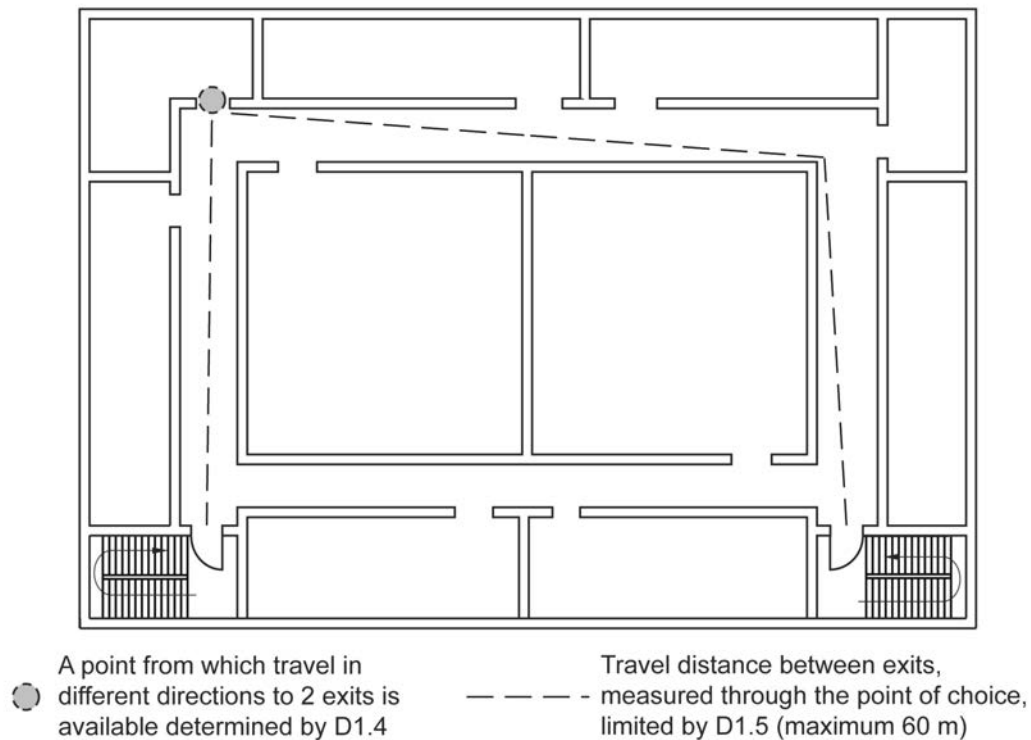
**Measure around any built obstructions**

It is necessary to measure around any walls, or other built obstructions (including a wall, a demountable wall, and permanent fixed seating). See [D1.15\(f\)](#) and [\(g\)](#).

Furnishings do not need to be taken into account

Generally, furniture, cars in a carpark and some non-built or non-fixed obstructions are not taken into account in the calculation of travel distance. However, there may be occasions when such matters must be taken into account.

Figure D1.15(2) and D1.15(3)

[Figure D1.15\(2\)](#) illustrates, by example, the method of measuring the distance of travel for Class 2 and Class 3 buildings and Class 4 parts.

Access and egress

Figure D1.15(2) Plan showing one method of compliance with Section D for Class 2 and Class 3 buildings and Class 4 parts

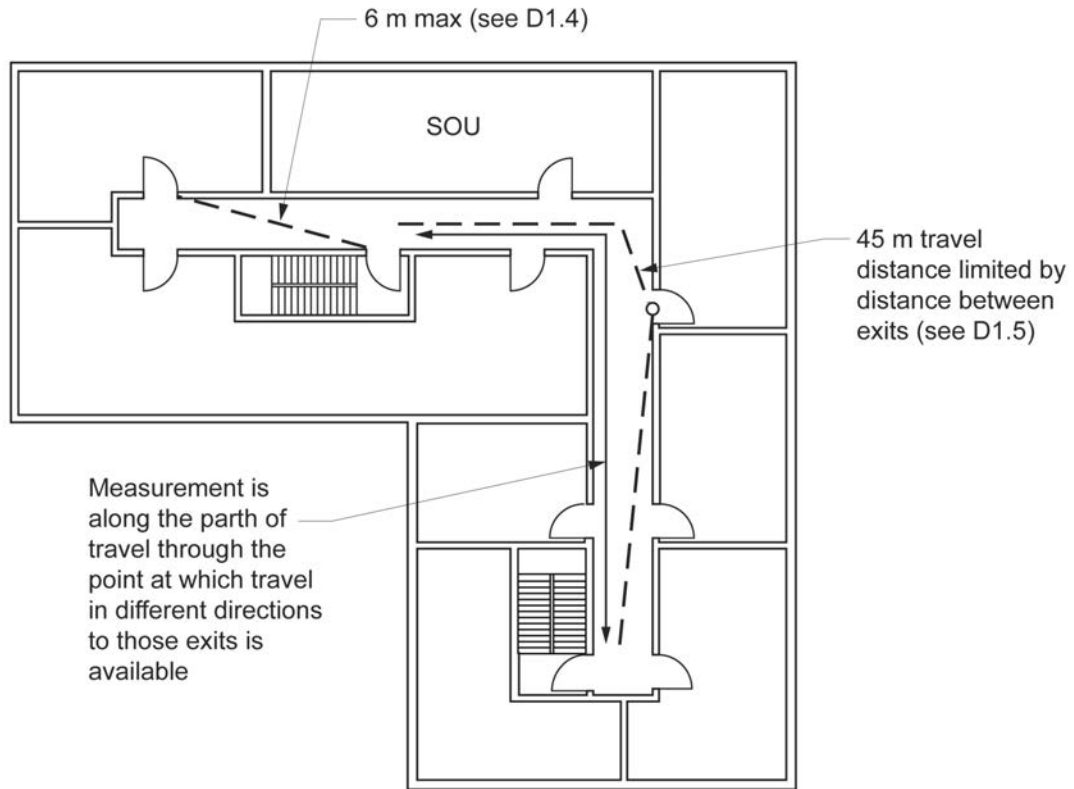
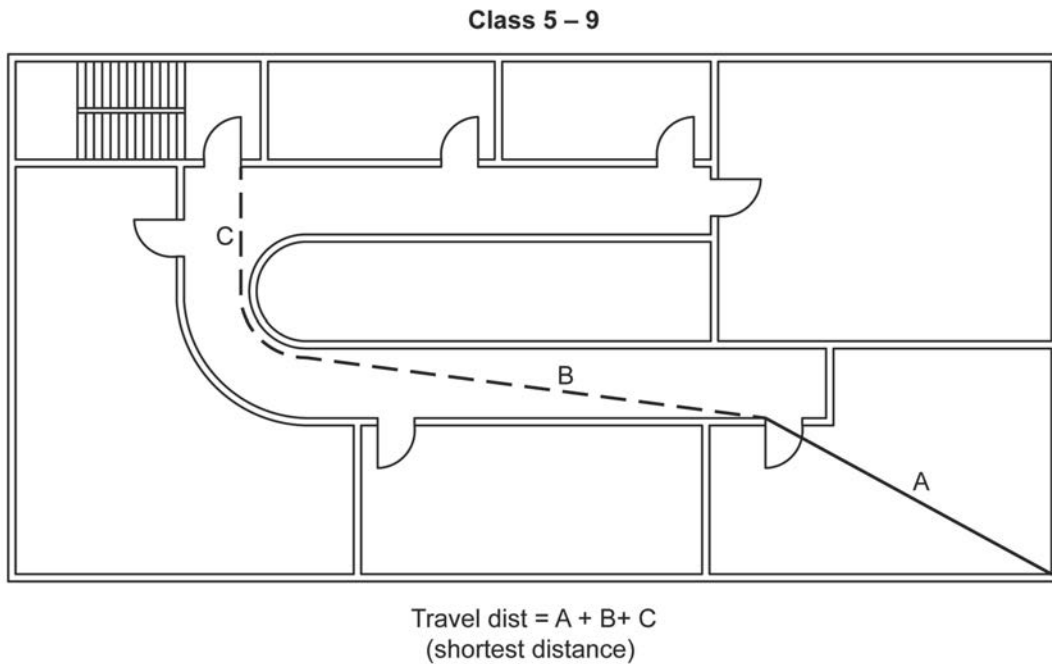

Figure D1.15(3) illustrates, by example, the method of measuring the distance of travel for Class 5–9 buildings.

Figure D1.15(3) Plan showing one method of compliance with D1.15 for Class 5–9 buildings



D1.16 Plant rooms, lift motor rooms and electricity network substations: Concession

Intent

To provide concessions for small plant rooms, lift motor rooms and Class 8 electricity network substations.

Why are concessions made?

Concessions (such as the use of a ladder in lieu of a stairway) are granted for small plant rooms, lift motor rooms and Class 8 electricity network substations for the following reasons:

- the usual occupants of a small plant room, lift motor room or Class 8 electricity network substation are trained personnel familiar with the room's hazards and layout and are capable of negotiating the service ladders in a safe manner;
- it is reasonable to assume that if the plant or lift motor room is small, so also will be the number of people who will ever occupy it;
- the small size of the room means that there is not a significant distance to travel to gain egress; and
- in the larger rooms which qualify for this concession, and multiple exits are provided, only one needs to be a stair.

Figure D1.16 illustrates some possible methods of using the concessions contained in D1.16.

Figure D1.16 Plans showing use of D1.16

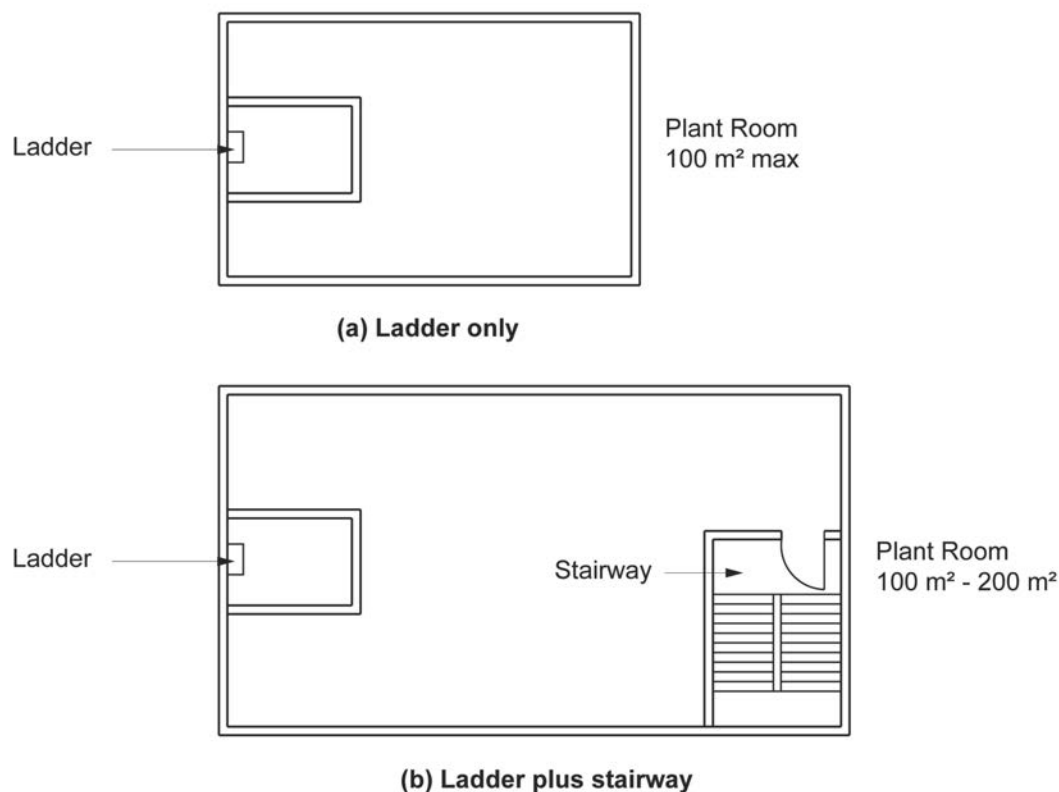

Part D2 Construction of exits

Objective

Functional Statements

Performance Requirements

The Objective and Functional Statements for [Section D](#) are at the beginning of [Section D](#) of this Guide. The Performance Requirements for [Section D](#) precede [Part D1](#).

Deemed-to-Satisfy Provisions

D2.0 Deemed-to-Satisfy Provisions

Intent

To clarify that the requirements of [DP1](#) to [DP6](#), [DP8](#) and [DP9](#) will be satisfied if compliance is achieved with [Parts D1](#), [D2](#) and [D3](#) in the case of all buildings, [Part G3](#) in the case of buildings with an atrium, [Part G4](#) in the case of buildings in alpine areas, [Part G6](#) in the case of occupiable outdoor areas, [Part H1](#) in the case of theatres, stages and public halls, [Part H2](#) for public transport buildings and [Part H3](#) for farm buildings and farm sheds. [DP7](#) is only required to be complied with if lifts are to be used to assist occupants to evacuate.

See [Deemed-to-Satisfy Provisions](#) of [D1.0](#).

D2.1 Application of Part

Intent

To clarify that [Part D2](#) does not apply within a sole-occupancy unit in a Class 3 building (except for [D2.13](#), [D2.14\(a\)](#), [D2.16](#), [D2.17\(d\)](#), [D2.17\(e\)](#), [D2.21](#) and [D2.24](#)) nor within a sole-occupancy unit in a Class 2 building or Class 4 part (except for [D2.13](#), [D2.14\(a\)](#), [D2.16](#), [D2.17\(d\)](#), [D2.17\(e\)](#), [D2.21](#) and [D2.24](#)).

Where a path to the door is not a path of travel to an exit

Except as outlined below, [Part D2](#) does not apply within sole-occupancy units in Class 2 or Class 3 buildings or Class 4 parts. The path from within the units to the door opening from them is not regarded as a path of travel to an exit. For these buildings, the path of travel to an exit commences at the outside of the door to the sole-occupancy unit. The path inside the unit, leading to the door, is part of the “evacuation route” (see the definition of this term in [Schedule 3](#)).

Exceptions

[D2.13](#) deals with the construction of stair treads and risers. For the safety of people moving within a sole-occupancy unit, it is important that stair treads and risers are safe to use.

[D2.14\(a\)](#) requires the installation of landings in stairways. For the safety of people moving within a sole-occupancy unit, it is important that landings be provided. This also links with [D2.13\(a\)](#) to limit the maximum number of risers in a flight of stairs to 18.

[D2.16](#) deals with barriers. Appropriate barriers are required to minimise the risk of people falling from a landing, balcony, roof with public access, flight of stairs and the like.

[D2.18](#) allows steeper stairs to infrequently used areas of a building. This concession applies to infrequently used areas such as machinery rooms, boiler rooms, etc and attics and storerooms in sole-occupancy units in Class 2 buildings and Class 4 parts. Under [D2.18](#), the designer has the choice of designing the stair, landing, barrier and handrail to comply with the appropriate provisions of the NCC or with AS 1657.

D2.2 Fire-isolated stairways and ramps

Intent

To maintain a sufficient level of fire safety to enable the use of fire-isolated stairways and ramps during an emergency.

Materials and construction methods

Access and egress

D2.2 sets the criteria for the materials and methods of construction used in stairways and ramps within a fire-resisting shaft.

Integrity of fire protection to be maintained—D2.2(a) and (b)

D2.2(a) and (b) set out the requirements for maintaining the integrity of the fire protection to the shaft of a fire-isolated stairway and ramp. These provisions reflect the fact that:

- occupants who use the stairway or ramp during a fire will expect to remain reasonably safe while evacuating, relying on the protection provided by the fire-isolated stairways and ramps to safely evacuate the building; and
- the stairway or ramp provides protection to the fire brigade to undertake search and rescue, and fire-fighting operations.

D2.3 Non-fire-isolated stairways and ramps

Intent

To maintain a sufficient level of safety for the use of stairways and ramps during an emergency.

Safe egress required

Where the installation of non-fire-isolated stairways and ramps is required by the NCC, they must provide a safe means of egress.

Such stairways and ramps will not be within a fire-resisting shaft, but they are nonetheless expected to be structurally sound, and constructed of materials which will not readily support combustion.

D2.3 requires that required non-fire-isolated stairways and ramps must be either constructed in accordance with D2.2 or the alternative options set out in D2.3(a)–(c).

Glued timber members—D2.3(c)(ii)

D2.3(c)(ii) permits the use of glued timber members under certain conditions. The aim of these conditions is to minimise the risk represented by certain types of glue which delaminate during a fire.

D2.4 Separation of rising and descending stair flights

Intent

To minimise the risk that an occupant mistakenly passes the lowest storey providing escape when evacuating.

Risk of missing the lowest egress floor—D2.4(a)

A danger exists that, in an emergency, a person may mistakenly pass the lowest floor providing direct egress to a road or open space. D2.4(a) minimises the risk of this by requiring that there is no direct connection between the rising and descending flight of a stairway at the level from which egress is obtained.

Separation required—D2.4(b)

If, in order to achieve D2.4(a), rising and descending flights of stairs are separated by construction (which may in places be common to the two flights), that construction must comply with the smoke separation requirements contained in Clause 2 of Specification C2.5.

Figure D2.4 illustrates one method of compliance with D2.4.

Access and egress

Figure D2.4 Plan showing one method of compliance with D2.4

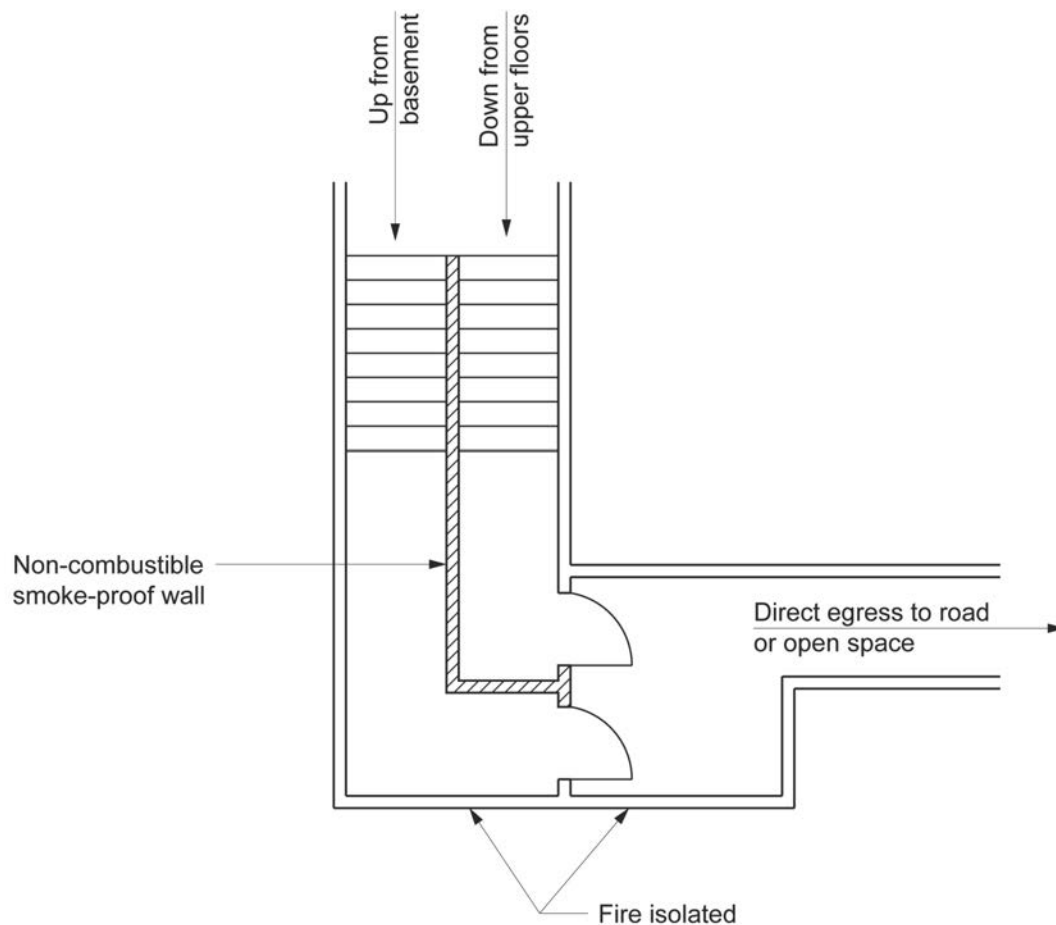

D2.5 Open access ramps and balconies

Intent

To specify the requirements for natural ventilation of smoke from an open access ramp or balcony which forms part of a required exit system.

Background

Table E2.2a allows the use of an open access ramp or balcony instead of stairwell pressurisation. If this option is chosen then D2.5 aims to prevent the entry of smoke into a fire-isolated exit by allowing smoke to vent naturally through an open access ramp or balcony, before it reaches the fire-isolated exit.

Ventilation openings—D2.5(a)

D2.5(a) sets out the requirements for ventilation openings where an open access ramp or balcony forms part of a required exit. This helps the evacuation of occupants using the exit by enabling the natural ventilation of smoke.

Enclosure permitted up to 1 metre—D2.5(b)

The reason for permitting an enclosure up to a height of one metre under D2.5(b) is to allow for a solid barrier or balcony.

No more than 25 percent enclosed above 1 metre—D2.5(b)

Note that the opening above one metre cannot be enclosed for more than 25 percent of the area of its sides. This allows for adequate smoke ventilation, while permitting some limited enclosure.

Figure D2.5 illustrates three methods of compliance with D2.5, and one method that does not comply.

Access and egress

Figure D2.5 Plan showing compliance and non-compliance with D2.5

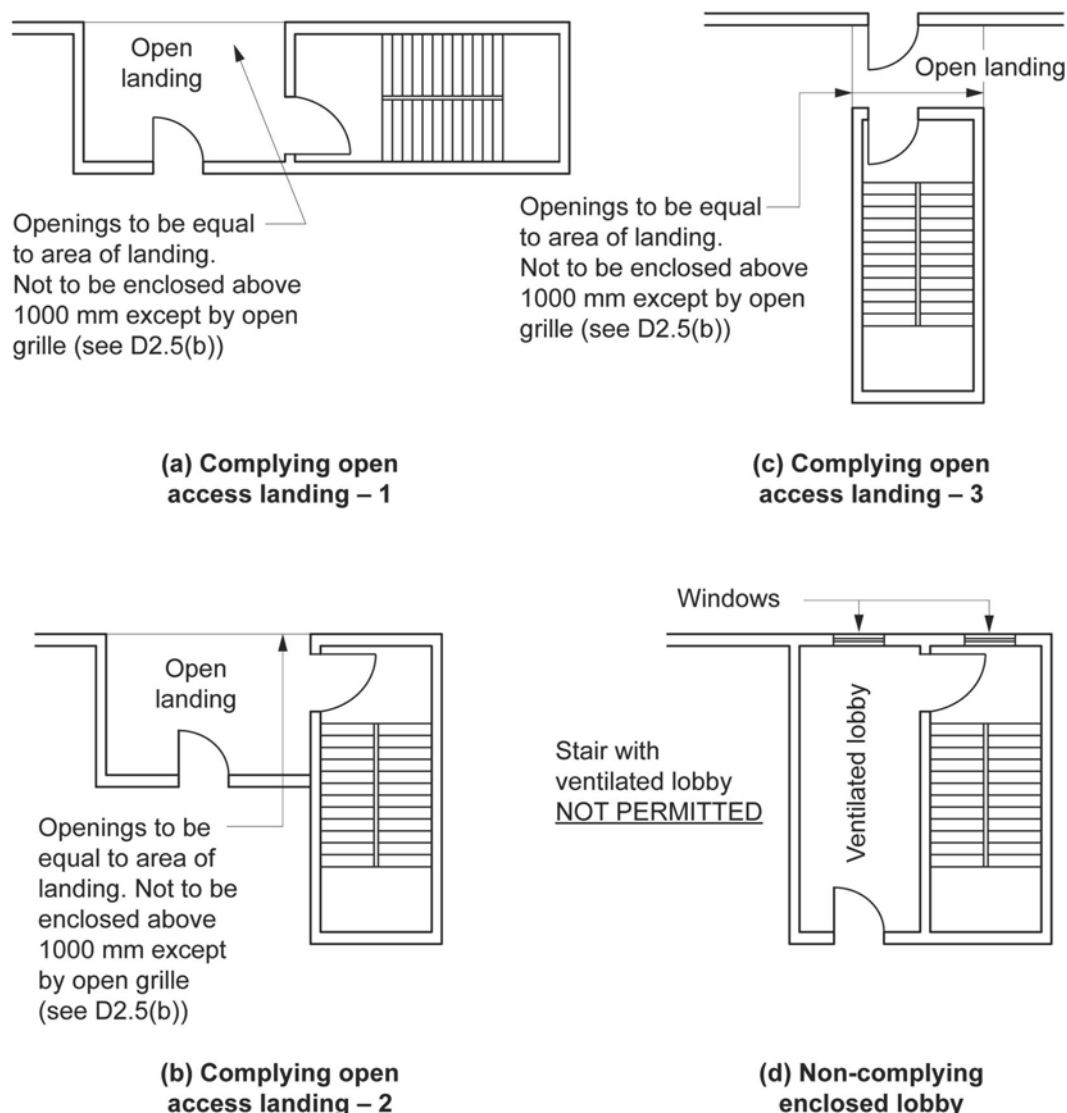

D2.6 Smoke lobbies

Intent

To prevent smoke entering a fire-isolated exit.

Smoke lobbies required by D1.7

D2.6 only applies to a smoke lobby required by D1.7.

A smoke lobby required by D1.7 must be constructed in accordance with each of the requirements in D2.6(a)–(d).

Intumescent putty—D2.6(b)(iii)

The intumescent putty referred to in D2.6(b)(iii) is intended to expand when exposed to fire, thus sealing any opening at the top of the lobby against smoke. If another material is proposed, it must be no less effective than the putty.

D2.7 Installations in exits and paths of travel

Intent

To maximise the safety of occupants evacuating to or within exits by limiting the types of services which may be located in exits and paths of travel.

Services in exits and paths of travel

Access and egress

Paths of travel within a building must continue to provide safe evacuation during an emergency. To achieve this, [D2.7](#) restricts the installation of certain services in fire-isolated exits, non-fire-isolated exits, and certain paths of travel to exits. [D2.7](#) should be read in conjunction with [C3.9](#), which lists the services that may penetrate fire-isolated exits.

Access to services—[D2.7\(a\)](#)

[D2.7\(a\)](#) prohibits access to services (apart from fire-fighting and detection equipment) from within a fire-isolated exit because they are a potential source of smoke or fire. Doors to service enclosures, if left open, could also hamper evacuation. The prohibition also means that maintenance equipment will not be placed within the enclosure.

Chutes and ducts—[D2.7\(b\)](#)

[D2.7\(b\)](#) prohibits any chute or duct carrying products of combustion from a boiler, incinerator fireplace or the like from being installed in:

- any required exit (i.e. both fire-isolated exits and non-fire-isolated exits); and
- any corridor, hallway, lobby or the like leading to a required exit (i.e. it does not apply to other paths of travel to an exit).

An opening from a chute or duct that forms part of a smoke hazard management system is permitted.

Gas and fuel services—[D2.7\(c\)](#)

[D2.7\(c\)](#) prohibits the installation of any gas or other fuel service in a required exit (i.e. both fire-isolated exits and non-fire-isolated exits). This prohibition does not apply to a path of travel to an exit.

Other services—[D2.7\(d\)](#)

Under specified conditions, [D2.7\(d\)](#) allows certain electrical and communication services to be located in:

- [D2.7\(d\)\(iv\)](#)—any required non-fire-isolated exit (installation in required fire-isolated exits is effectively prohibited by the reference to [D2.7\(a\)](#)); and
- [D2.7\(d\)\(v\)](#)—any corridor, hallway, lobby or the like leading to a required exit (i.e. it does not apply to other paths of travel to an exit).

Electrical wiring—[D2.7\(e\)](#)

[D2.7\(e\)](#) allows electrical wiring to be installed within a fire-isolated exit if the wiring is associated with specified equipment and systems serving the exit or systems used for alarms and monitoring of fire safety systems.

D2.8 Enclosure of space under stairs and ramps

Intent

To minimise the risk of a fire starting under a stairway and endangering the safe evacuation of the building occupants.

Fire risk from spaces under stairways or ramps

Spaces under stairways are often used for a range of purposes. It is common practice to have a cleaner's store located in such spaces. These stores often contain flammable cleaning agents.

Required fire-isolated stairways or ramps—[D2.8\(a\)](#)

Space is part of the fire-isolated shaft

If the stairway or ramp is fire-isolated, and the space below is part of the fire-isolated shaft, that space must not be used as a cupboard or the like.

Space is not part of the fire-isolated shaft

If the stairway or ramp is fire-isolated, and the space below is not part of the fire-isolated shaft, that space may be used as a cupboard etc. This could be created by placing a fire rated slab under the flight of stairs. This is shown in [Figure D2.8](#).

Required non-fire-isolated stairways or ramps—[D2.8\(b\)](#)

If the stairway or ramp is non-fire-isolated, any cupboard underneath must be fire separated from the stairway. The construction must have an FRL of 60/60/60, with a self-closing –/60/30 fire door.

Figure D2.8 Section showing enclosure of space below fire-isolated stairway

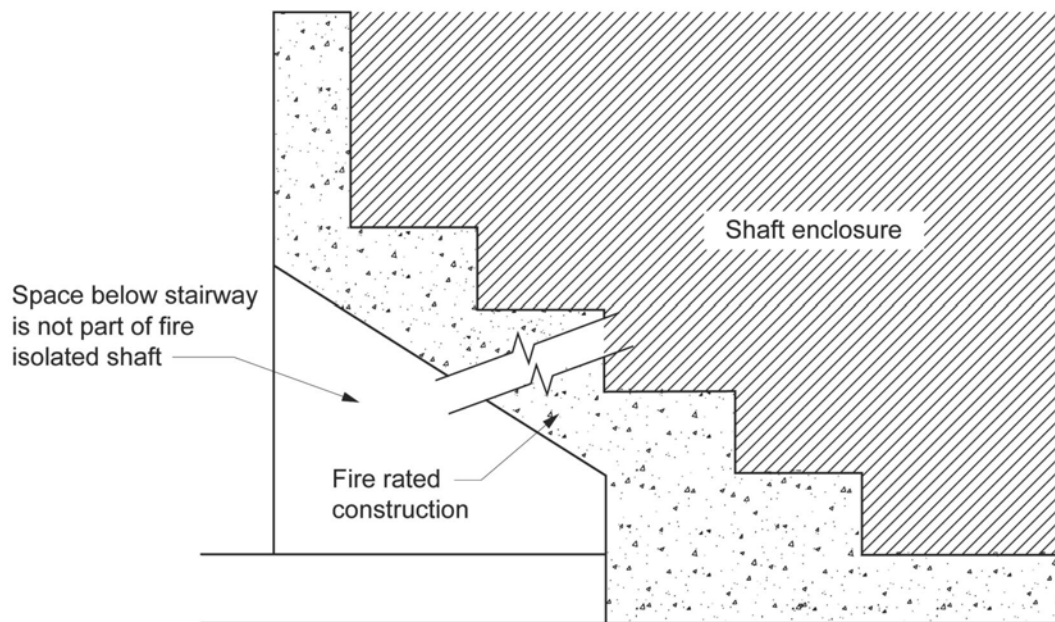

D2.9 Width of stairways and ramps

Intent

To establish requirements for the safe use of wide stairways and ramps.

Width of two metres—D2.9

Most people using stairways tend to move in easy reach of a handrail or barrier. This tendency is particularly pronounced during an emergency evacuation. The D2.9 maximum of two metres (effectively permitting a reach of one metre to either side) is considered reasonable.

Wider stairways are permitted, with more than two metres between the handrails. However, for the purposes of calculating required widths, such stairways are deemed to add no more than two metres to the aggregate required width.

Example

If a building is required to have a path of travel to an exit with a width of four metres, a stairway with four metres of width between its handrails will not comply, as it will be deemed to only provide two metres of width. Therefore, an intermediate handrail should be provided or a further two metres must be provided by other means.

D2.10 Pedestrian ramps

Intent

To allow the use of a ramp as a required exit, instead of a stairway.

Ramps instead of stairways—D2.10(a)

Under D2.10(a), a fire-isolated ramp may be used instead of a fire-isolated stairway if:

- the construction enclosing the ramp complies with the requirements of the NCC for fire-isolated stairways; and
- the width and ceiling height of the ramp complies with the requirements of the NCC for fire-isolated stairways.

Specified ramp gradients—D2.10(b)

D2.10(b) specifies safe gradients for a ramp used as a required exit. They are determined having regard to likely users.

Ramps for people with a disability, as specified by Part D3, require a gradient of not less than 1:14, and in other cases, not less than 1:8.

D2.10(b) relates to a ramp being used as a fire-isolated exit. If the ramp is also used for access it must comply with the requirements for such ramps in Part D3.

Access and egress

Surface of a ramp—D2.10(c)

Under [D2.10\(c\)](#), the floor surface of a ramp must be slip resistant to avoid people slipping over and injuring themselves. The surface must have a slip-resistance classification when tested in accordance with AS 4586. There are a number of parameters to be considered: two ramp slopes, two tests (the wet pendulum test or the oil-wet inclining platform test) and there are two conditions (dry or wet).

To determine the appropriate slip-resistance classification surface to apply to a ramp, it is necessary to determine the conditions (either dry, wet or both) that the relevant surface is likely to be subjected over the life of the building.

A dry surface is one that is not normally wet or not likely to become wet other than by accidental spill.

A wet surface is one that is normally wet or likely to be made wet other than by an accidental spill. This could include a surface that is exposed to weather such as an external ramp, and a surface that may, on occasions, become wet such as a surface in a transitional space like an entrance airlock or entrance lobby.

Other potentially wet affected areas such as bathrooms are not included in the NCC provisions unless they have a ramp incorporated in them.

Surfaces affected by commercial or industrial processes are regulated by the relevant workplace safety authority.

D2.11 Fire-isolated passageways**Intent**

To make a fire-isolated passageway safe from a fire outside.

Protection of fire-isolated passageways—D2.11(a)

Under [D2.11\(a\)](#), the required FRL of a fire-isolated passageway must (except as set out in [D2.11\(b\)](#)):

- [D2.11\(a\)\(i\)](#)—not fall below the required FRL of any fire-isolated stairway or ramp which discharges into the passageway; and
- [D2.11\(a\)\(ii\)](#)—in every other case, not fall below 60/60/60.

The FRL test is for a fire outside the passageway, in another part of the building. It is extremely unlikely that a fire will occur inside a fire-isolated passageway.

Top of a fire-isolated passageway—D2.11(b)

Despite the requirements of [D2.11\(a\)](#), [D2.11\(b\)](#) allows the top of a fire-isolated passageway to be constructed without an FRL on the condition that its walls are built up to either of the following:

Non-combustible roof covering—D2.11(b)(i)

The top construction of a fire-isolated passageway need not have an FRL if the walls continue to the underside of a non-combustible roof covering.

Incipient spread of fire resistant ceiling—D2.11(b)(ii)

Under [D2.11\(b\)\(ii\)](#), a fire-isolated passageway need not have a top construction with an FRL, and need not have its walls extend to the underside of a non-combustible roof covering if the walls extend to the underside of a ceiling which is resistant to the incipient spread of fire for at least 60 minutes.

Access and egress

Figure D2.11 Elevations showing alternative methods of protecting a fire-isolated passageway from a fire in another part of the building

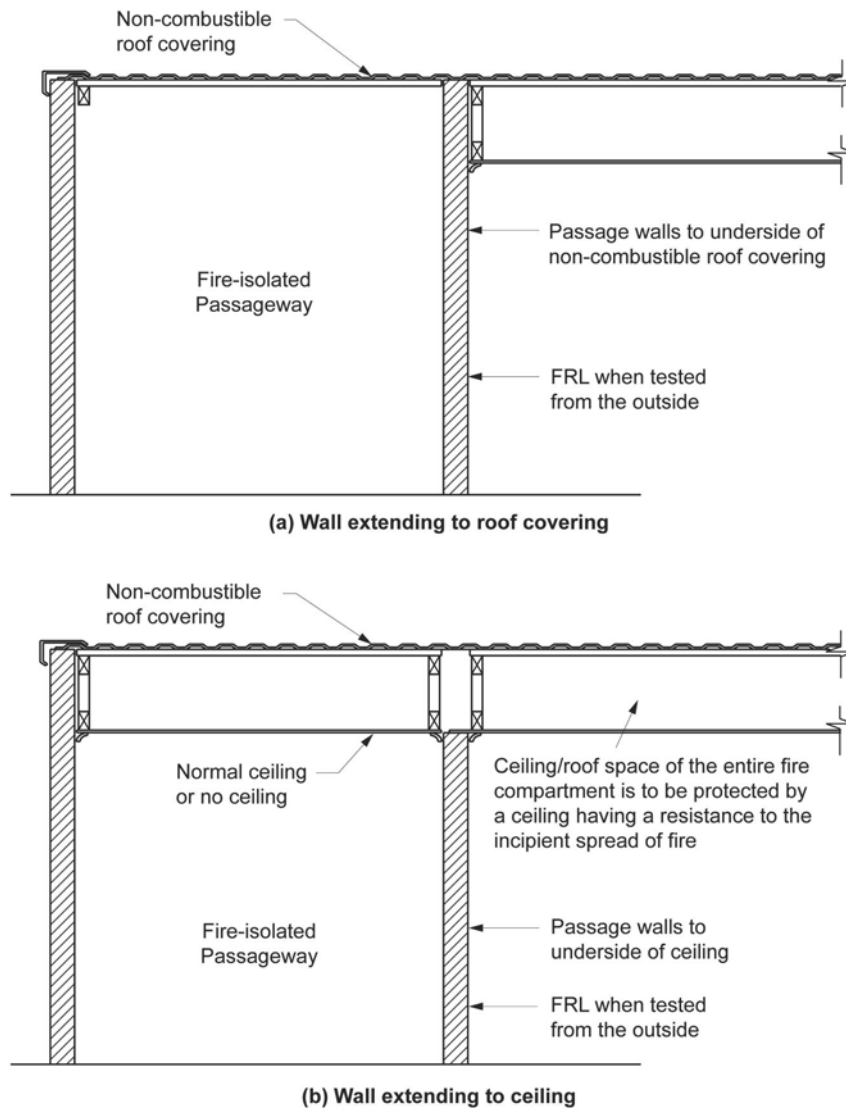

Such a ceiling will prevent the ignition of combustible materials in the roof or ceiling space from a fire below. For the ceiling to be effective, the whole fire compartment surrounding the passageway must also be covered. This will minimise the risk of a fire spreading into the fire compartment’s roof or ceiling space, and entering the passageway from above. An incipient spread of fire resistant ceiling is not required over the passageway, because it is extremely unlikely that a fire will start there.

It is important that the junction between the top of the wall and the incipient spread of fire resistant ceiling is adequately sealed to maintain the integrity of the barrier.

Figure D2.11 illustrates this comment.

D2.12 Roof as open space

Intent
To allow a roof of a building to be used as a point of discharge from an exit.

Roof must be protected

Exits must provide egress to a road or an open space. D2.12 applies where the open space is provided by a roof. To maximise the safety of people who must use a roof as the point of discharge from an exit, such a roof is required:

- D2.12(a)—to have an FRL sufficient to protect people on the roof from fire below during evacuation from the building; and

Access and egress

- **D2.12(b)**—not to have any openings within three metres of the path of travel to the portion of the roof being used as open space, and from that portion to a road. This protects a person passing such openings from being affected by a fire on the other side of such openings.

Safe path of travel to road

Once on the roof, a safe path of travel must be provided to a road. See [D1.10](#).

D2.13 Goings and risers**Intent**

To enable the safe movement of people using stairways.

Background to D2.13—goings and risers

The going and riser requirements in [D2.13](#) date from a substantial reform carried out in 1987, based on international research.

Safe stairway requirements**No more than 18 nor less than 2 risers—D2.13(a)(i)**

[D2.13\(a\)\(i\)](#) states that a stairway must have no more than 18 nor less than 2 risers in each flight. Where there are less than 2 risers in a flight, they do not comprise a stairway for the purposes of the NCC.

Eighteen risers is considered to be the maximum reasonable number that an average person can negotiate before requiring a rest.

Winders are counted as part of the maximum number of 18 risers. More than one riser is considered necessary for a person to observe and adjust to a change in level.

Going and riser dimensions—D2.13(a)(ii) and (iii)

The purpose of [D2.13\(a\)\(ii\)](#) and [\(iii\)](#) and [\(b\)\(ii\)](#) and [\(iii\)](#) is to achieve constant going and riser dimensions deemed safe for people to walk up and down. This minimises the risk of people overstepping during descent on uneven stairs (due to short goings) and tripping on ascent (due to high risers). [Table D2.13](#) expresses ratios between goings and risers which are considered safe for use.

[D2.13\(a\)\(iii\)](#) and [\(b\)\(ii\)](#) accounts for conditions such as movement of materials due to atmospheric moisture changes or minor deviations related to variations in materials which affect finished stair dimensions.

[Figure D2.13\(1\)](#) illustrates adjacent risers within a flight with minor deviations in the materials affecting the finished stair dimensions. The nominated riser height is exceeded by riser A. As a consequence riser height B is less than the nominated riser height. The difference between riser A and riser B cannot exceed 5 mm.

[Figure D2.13\(2\)](#) illustrates an entire flight with minor deviations in the materials affecting the finished riser dimensions. In addition to the 5 mm difference permitted between adjacent goings or risers, the maximum difference between the smallest and largest going or riser within a flight must not exceed 10 mm.

Despite the deviations shown in both [Figure D2.13\(1\)](#) and [Figure D2.13\(2\)](#), the stairs in the flight are deemed constant.

Irrespective of any minor deviations permitted by [D2.13\(a\)\(iii\)](#) and [\(b\)\(ii\)](#), finished going and riser dimensions must not exceed the limitations stipulated in [Table D2.13](#).

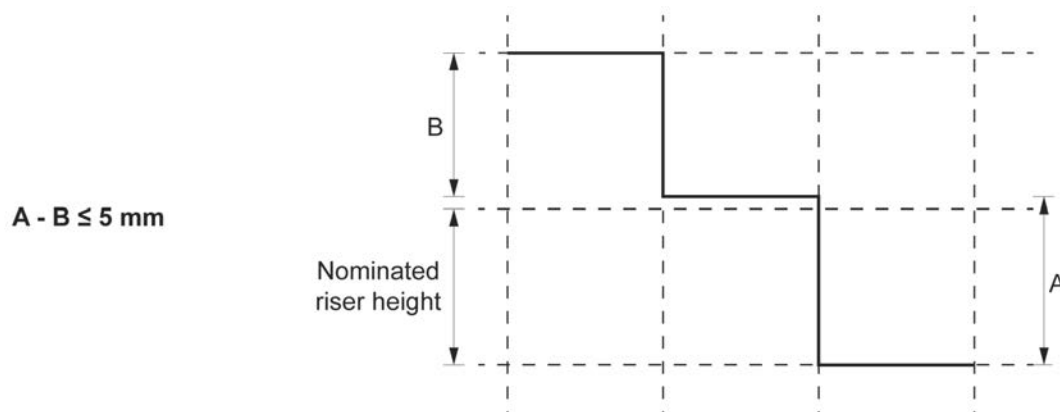
Figure D2.13(1) Deviations in adjacent risers

Access and egress

Notes:

1. A = larger riser of two adjacent risers.
2. B = smaller riser of two adjacent risers.
3. This figure only shows deviations in risers, however the same principle can apply for goings.

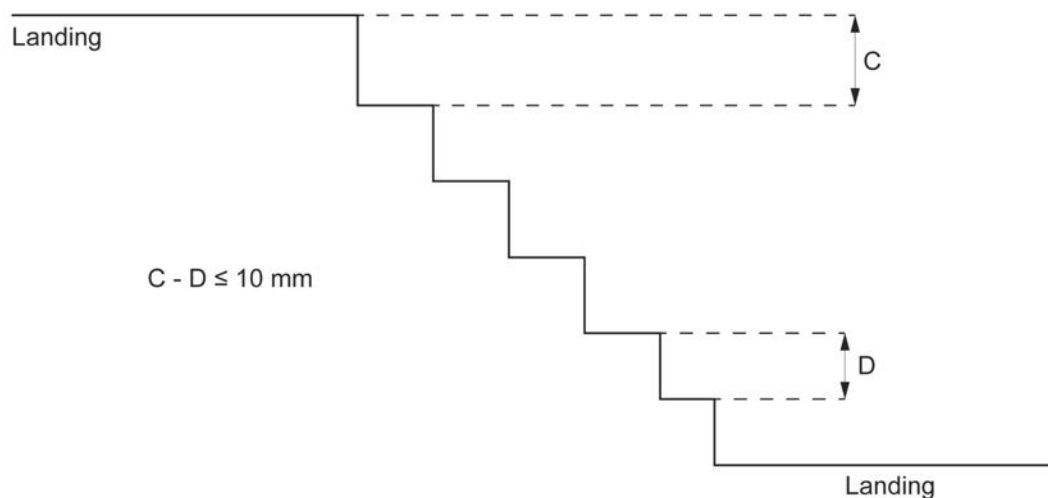
Figure D2.13(2) Deviations over a flight**Notes:**

1. C = largest riser of the flight.
2. D = smallest riser of the flight.
3. This diagram only shows deviations in risers, however the same principle can apply for goings.

Openings in stair risers—D2.13(a)(iv)

D2.13(a)(iv) allows the use of open stair risers. However, it limits the opening to 125 mm to minimise the risk to children.

Treads—D2.13(a)(v)

Under D2.13(a)(v), treads must have a surface or nosing strip which prevents people slipping over and injuring themselves. In each case the surface or nosing strip must have a slip-resistance classification when tested in accordance with AS 4586. Similar to D2.10(c) there are two tests (the wet pendulum test or the oil-wet inclining platform test) and two conditions (dry or wet) to be considered.

Solid treads—D2.13(a)(vi)

Under D2.13(a)(vi), where a stairway is of a specified height, solid treads must be used so that people cannot see through them. This minimises the risk to people affected by vertigo.

Change in direction—D2.13(a)(vii)

Under D2.13(a)(vii), stairways in Class 9b buildings require a change in direction of at least 30° at specified points. This limits the distance a person can trip or fall down the stairways. This sort of occurrence is more likely to take place in buildings with large numbers of people who are unfamiliar with the building or its stairways.

Winders in lieu of landings—D2.13(a)(viii) and (b)(i)

Under D2.13(a)(viii), winders in lieu of landings are not permitted in a required stairway. Under D2.13(b)(i) winders in lieu of landings are permitted in non-required stairways provided that not more than 3 winders in lieu of a quarter landing or not more than 6 winders in lieu of a half landing are used.

Sloping public walkways — D2.13(c)

When a stairway discharges directly to a sloping public walkway or road, it is extremely difficult to maintain a constant riser height without setting the stairway back from the walkway. D2.13(c) therefore allows a variation in the riser height in these situations.

See Figure D2.13.

Figure D2.13 Stairway for sloping public walkway or road

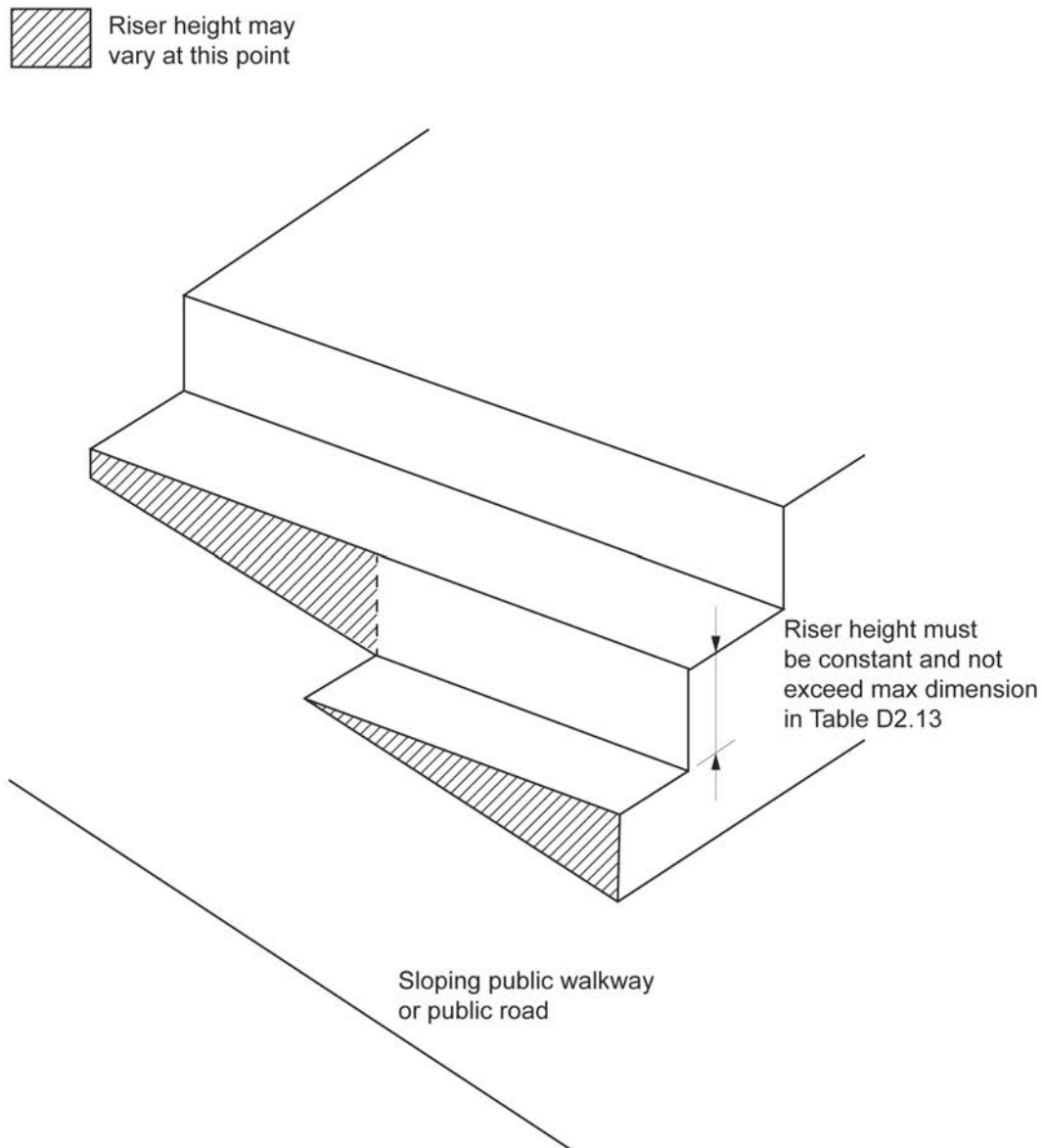

Table D2.13

Purpose

Table D2.13 addresses both public and private stairways, and provides information on acceptable maximum and minimum risers and goings. It also illustrates the method of measuring the rise and going of stairway treads and the maximum gap between treads referred to in D2.13(a)(iv).

Stairway that is curved or circular in plan view

Note 2 of Table D2.13 allows the use of a stairway which is curved, or circular in plan view.

D2.14 Landings

Intent
To enable the safe movement of people using stairways.

Purpose of a landing in a stairway

The purpose of a landing is to limit the number of risers to provide a rest area for the people using the stairway, and to allow the stairway to change direction if needed.

Maximum grade of 1:50—D2.14(a)

Access and egress

The maximum grade of 1 in 50 required under D2.14(a) makes sure that the landing is as level as possible, but still allows a slight slope for drainage if necessary.

Minimum landing length—D2.14(a)(i)

The minimum length of a landing allows people using the stairway to rest, and reduces the risk of a person falling more than one flight of stairs.

Surface of a landing—D2.14(a)(ii)

Under D2.14(a)(ii), landings must have a surface or strip at the edge of the landing to prevent a person slipping over and injuring themselves. In each case the surface or edge strip must have a slip-resistance classification when tested in accordance with AS 4586. Similar to D2.10(c) there are two tests (the wet pendulum test or the oil-wet inclining platform test) and two conditions (dry or wet) to be considered.

Class 9a buildings—D2.14(b)

D2.14(b) provides two options for landings in Class 9a buildings. The aim is to aid the use of a stretcher.

Figure D2.14 illustrates the method of measuring the length of landings as required by D2.14.

Figure D2.14 Method of measuring the length of landings as required by D2.14

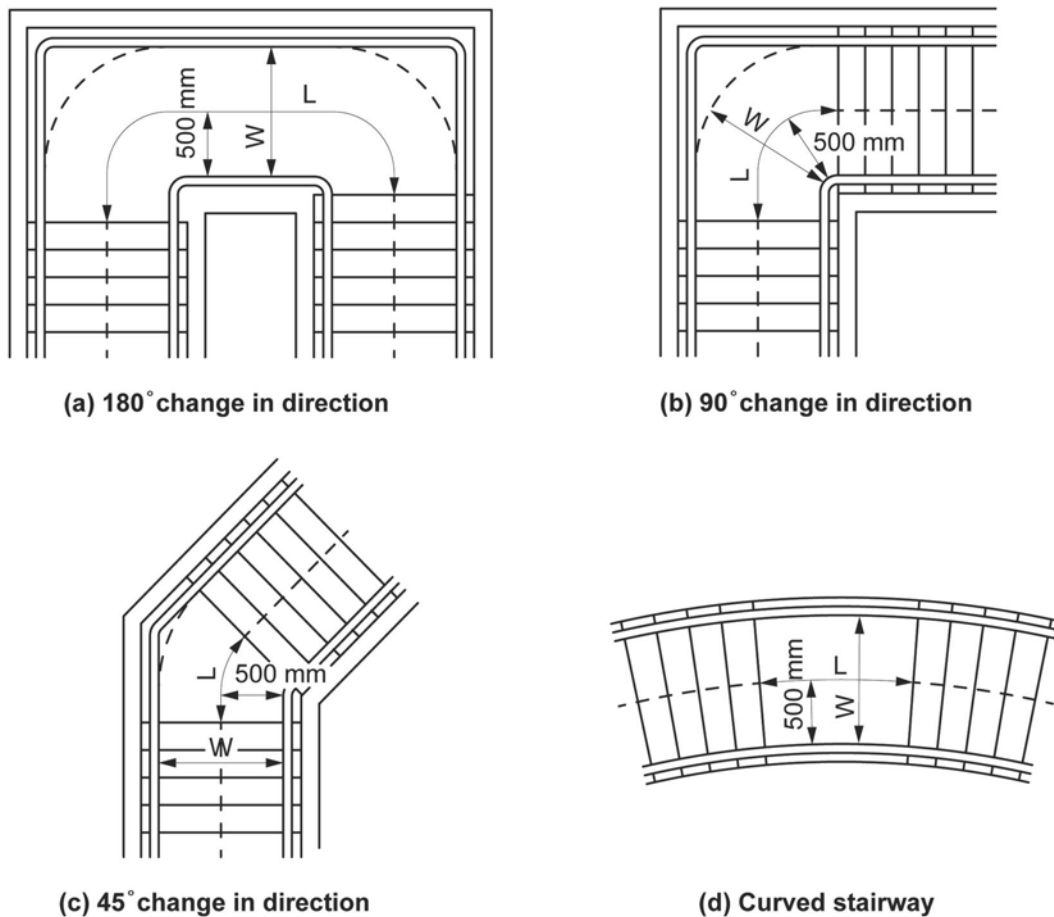

D2.15 Thresholds

Intent
To reduce the risk of a person tripping on an unseen step in a doorway.

Step prohibited too close to a door

It is difficult to see a step or ramp which is too close to a door. People can trip, particularly if the ramp or step is on the opposite side of a door. Figure D2.15(1) illustrates the area where a step is not allowed in a doorway.

Access and egress

Figure D2.15(1) Illustration of where a step is not allowed in a doorway

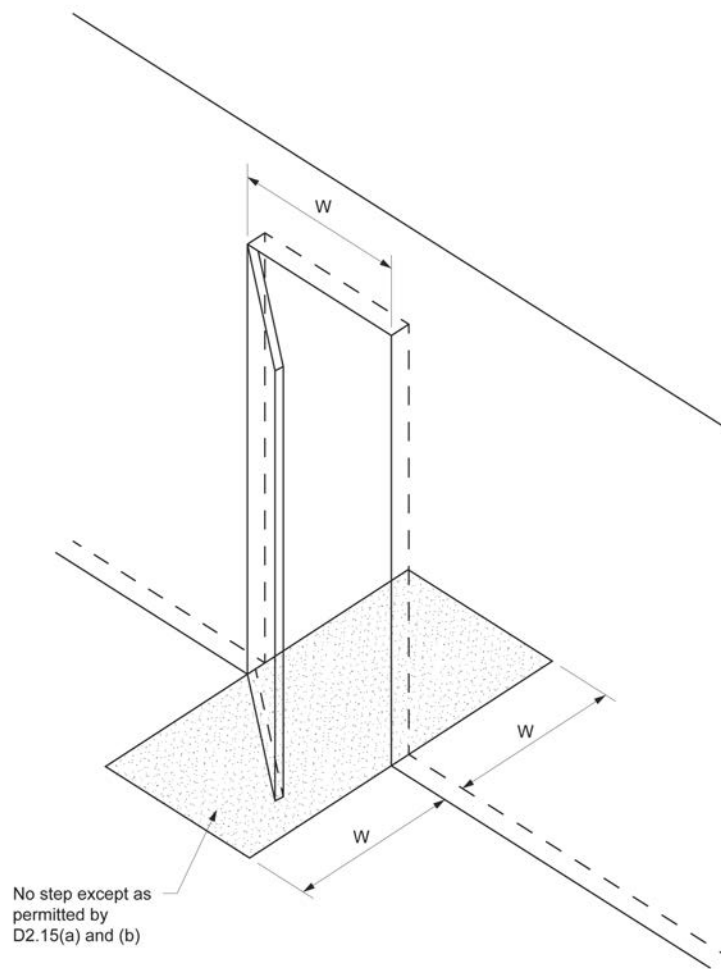
**Concessions—D2.15(a), (b) and (c)**

Concessions are granted in specified circumstances. These include:

- [D2.15\(a\)](#)—in the patient care areas of a hospital; and
- [D2.15\(b\)](#)—in Class 9c buildings; and
- [D2.15\(c\)](#)—in a building required to be accessible by [Part D3](#).
- [D2.15\(d\)](#)—in other buildings, to allow for weatherproofing under an external door.

Class 9c buildings— D2.15(b)

The threshold of a doorway in a Class 9c building, which is subject to a change in level, may incorporate a ramp and cannot be provided with a step. This is a safety requirement due to the varying mobility of the residents. The ramp may have a maximum slope of 1 in 8 and a maximum height of 25 mm. [Figure D2.15\(2\)](#) illustrates an example of a ramp at a doorway threshold in a residential care building.

Access and egress

Figure D2.15(2) Illustration of ramp at doorway threshold in a residential care building

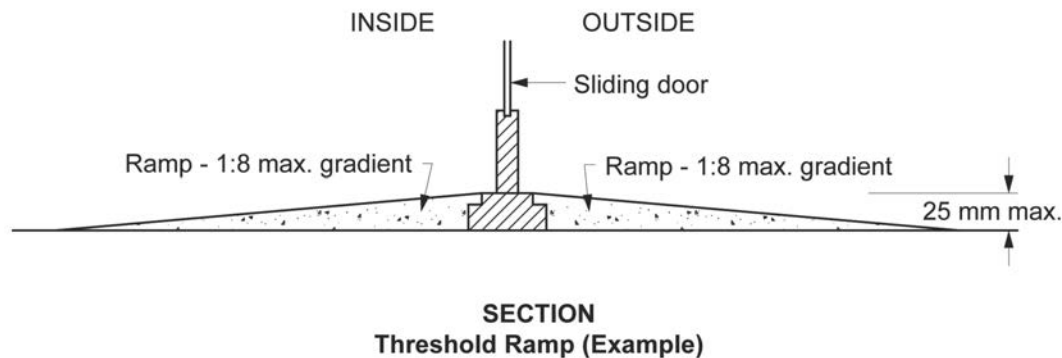

D2.16 Barriers to prevent falls

Intent

To minimise the risk of a person falling from a roof, stairway, raised floor level or the like.

D2.16 and DP3

This is the **Deemed-to-Satisfy Provision** for DP3.

Barriers to prevent falls

D2.16(a) sets out when barriers are required. It should be noted that a barrier is only required where an identified hazard of falling is present. D2.16(b) provides an exemption for the installation of barriers in areas that would be inappropriate due to their inherent functions. These areas include at the perimeter of a stage, rigging loft, loading dock or the like. The reference to 'or the like' could include such areas as the passenger loading points on railway platforms. Other exemptions apply to retaining walls, areas covered by D2.18 and barriers provided to openable windows as required by D2.24.

The following specific provisions applicable to barriers are contained in **Table D2.16a**

1. Barrier heights

- a The slope of 1:20 is included to distinguish between the floor of a ramp and the floor of a landing that has a slight slope for drainage purposes. The result is that if the floor has a slope of less than 1:20, it is considered as a landing and must have a barrier with a height of not less than 1 m above the floor. In all other cases, the floor is considered to be a ramp, where the barrier must have a height of not less than 865 mm above the floor.
- c For certain Class 9b buildings, lesser heights are permitted to allow uninterrupted viewing of a performance. These lower heights are not expected to be a problem, because unaccompanied children are unlikely to be present.

Note 1 When measuring the height of the barrier, allowance should be made for floor finishes such as tiles and carpet when they are to be installed at a later time.

Note 2 A transition zone is permitted where the barrier above the stair nosings and landing meet. This overcomes the need for a step in the top of the barrier to maintain the 1 m height above the landing. See Figure D2.17(2).

2. Barrier openings

- a Fire-isolated exits; and
- b Class 7 buildings (other than car parks) and Class 8 buildings, which are assumed to have a low occupancy rate,

where unaccompanied children are unlikely to be present, attract a concession for the permitted size of openings.

- c For non-fire-isolated stairways and ramps, a 125 mm sphere must not be able to pass through any opening.

3. Barrier climbability

Barrier climbability describes the construction details regarding height and the opening between any horizontal or near horizontal elements in a barrier. To lessen the risk of children climbing and falling from high balconies, barrier design must not incorporate horizontal rails or other similar features.

Figures D2.16(1) and D2.16(2) illustrate the various requirements for barriers.

Figure D2.16(1) Illustration of barrier heights and spacings

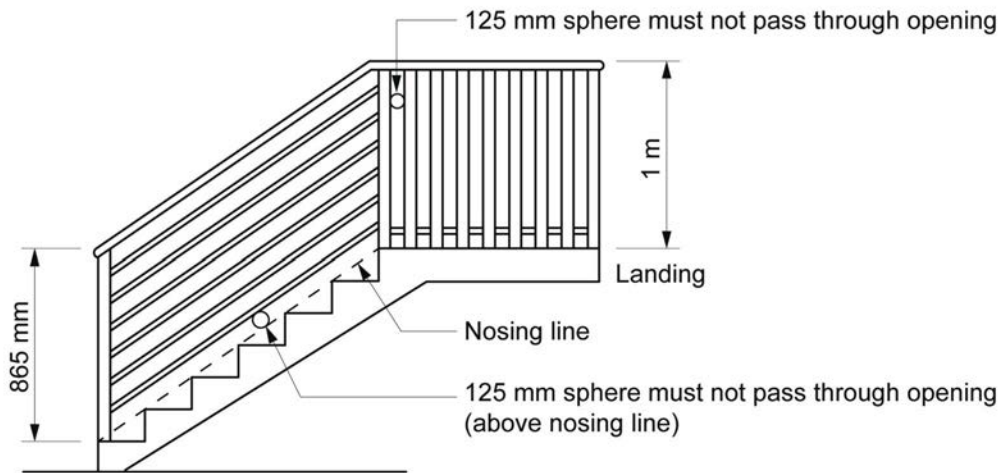

(a) Stairways – Table D2.16a 2(c)

Figure D2.16(2) Illustration showing when barriers are required

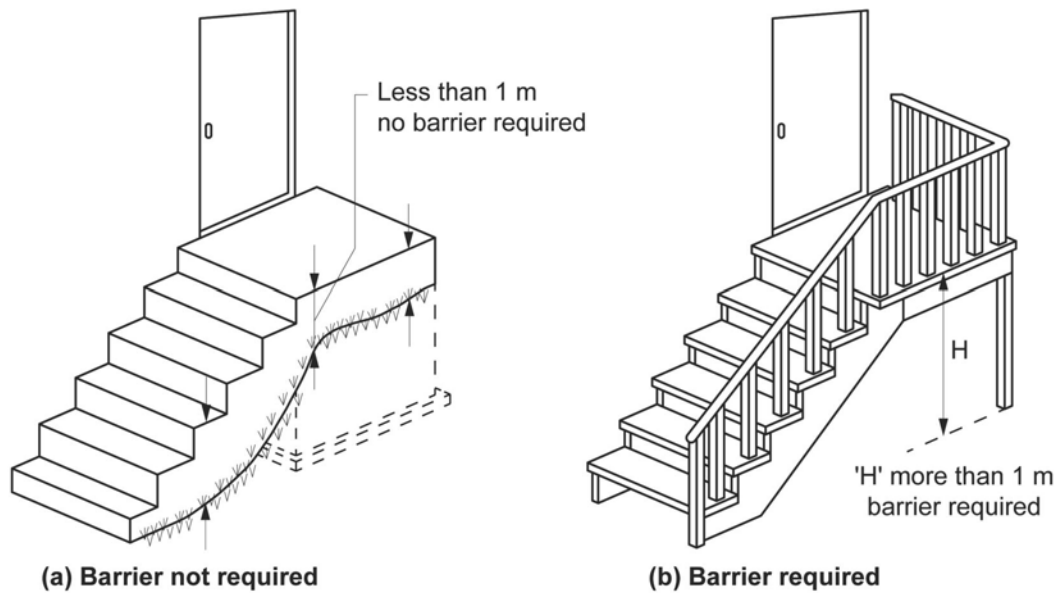

Wire barriers

Wire barriers deflect under loading conditions, even when tightly tensioned, and therefore some doubt has been expressed as to whether they can meet the requirements of Table D2.16a 2(c) not to permit a 125 mm sphere to pass through. Also, some concern has been expressed that in time the wire tends to lose its tension and could therefore allow the passage of the 125 mm sphere.

In 2003, the ABCB commissioned research to determine how to overcome these difficulties. The results of this research is contained in [D2.16\(d\)](#).

[D2.16\(d\)](#) allows the use of wire barriers without the need to demonstrate that the barrier would not permit the passage of a 125 mm sphere provided the wire diameter, lay and type, post spaces, etc. are satisfied. If it is proposed to differ any of the specified criteria, then it would be necessary to demonstrate to the approval authority that the Performance Requirement had been satisfied by the use of a Performance Solution.

To assist in the application of [D2.16\(d\)](#), the following terms have been defined:

- Continuous – where the wire spans three or more supports.

Access and egress

- Non-continuous – where the wire only spans between two supports.
- Pulley block – a device consisting of a wheel in which a wire runs around to change its direction.
- Permissible deflection – is the allowable bending of the wire.
- Support rails – are horizontal components of the barrier system that span across the top and bottom to provide structural support.

D2.16(d) provides for three alternative systems, namely—

- horizontal wire systems; and
- non-continuous vertical wire systems; and
- continuous vertical or near vertical wire systems.

For the purpose of D2.16(d), a wire barrier consists of a series of tensioned wire ropes connected to either vertical or horizontal supports serving as a guard to minimise the risk of a person falling from a roof, stairway, raised floor level or the like.

A wire barrier excludes wire mesh fences and the like.

Tables D2.16a and D2.16b contain tension requirements for wires in vertical and horizontal wire barrier systems with varying post spacings, wire spacings and wire types, whereas Table D2.16c only contains deflection requirements for use in horizontal and vertical barrier systems. With the latter, deflection is referred to as an “offset” and is limited to systems that use non-continuous wires. The figures contained in the three tables were derived from testing the spacing combinations in order to prevent the passage of a 125 mm diameter solid cone penetrating between the wires at a predetermined force. The tables also contain additional guidance to ensure that the wire tension will be maintained during the life of the barrier.

For safety, sharp ends of wires at terminations and swages need to be removed and no wire end should protrude more than half the diameter of the wire from the swage or termination fitting.

D2.17 Handrails

Intent

To provide handrails to a stairway or ramp, in corridors in Class 9a and 9c buildings and in corridors required to be accessible by people with a disability.

D2.17 addresses requirements regarding the location, spacing and extent of handrails. Where both barrier and handrail matters require consideration, D2.17 must be read in conjunction with those of D2.16.

Handrail location and separation—D2.17(a)(i)–(ii)

D2.17(a)(i) and (ii) set out the location and separation requirements for handrails. For intermediate handrails, see the requirements in D2.9.

Handrail heights

Primary schools—D2.17(a)(iii)

D2.17(a)(iii) requires a second handrail located at a practical height between 665 mm and 750 mm in a primary school, to aid children who are generally shorter than adults.

865 mm height requirement—D2.17(a)(iv)

Under D2.17(a)(iv), the height of handrails is a minimum of 865 mm, so that they are comfortable to use for most people and provide adequate stability support and assistance.

Continuous handrails

D2.17(a)(v) requires a continuous handrail between stair flight landings. It does not apply around a landing between flights, as such a requirement would often be impractical.

Obstructions placed on handrails to prevent people deliberately sliding down them must be considered on a case by case basis to determine whether a hand hold is broken. Ball type stanchions at the top of supports to handrails may be permissible. See Figure D2.17(1).

Handrails in exits

D2.17(a)(vi) requires handrails in a required exit serving an area required to be accessible, to comply with clause 12 of AS 1428.1, to facilitate use by people with a disability.

Handrails in Class 9a corridors—D2.17(b)(i)

The D2.17(b)(i) provisions requiring handrails on at least one side of corridors in a Class 9a building are intended to assist patients.

Handrails in Class 9c corridors—D2.17(b)(ii)

Access and egress

The [D2.17\(b\)\(ii\)](#) provisions requiring handrails in corridors in a Class 9c building are intended to assist residents. The handrails are required on both sides of the corridor to assist residents accessing the common areas such as dining rooms and recreation rooms in their day to day living.

People with a disability—[D2.17\(c\)](#)

[D2.17\(c\)](#) is provided to remind users of the NCC that there are specific requirements for handrails to provide access for people with a disability under [Part D3](#).

Handrails for sole-occupancy units in Class 2 or 3 buildings or a Class 4 part—[D2.17\(d\)](#)

[D2.17\(d\)](#) requires handrails on at least one side of a stairway or ramp. The top rail of a barrier could be a handrail. The handrail must extend the full length of the flight or ramp except where the handrail is associated with the barrier, in which case the handrail can terminate where the barrier is allowed to terminate. This would allow for the barriers of geometric stairways such as elliptical, spiral, circular or curved stairways to finish a few treads from the bottom of the stairway. A handrail is not required for winders if a newel post is installed to provide a handhold.

Example

A handrail is not required for a flight of only 5 risers as the change in elevation would be less than 1 m.

Figure D2.17(1) Illustration of ball-type stanchions

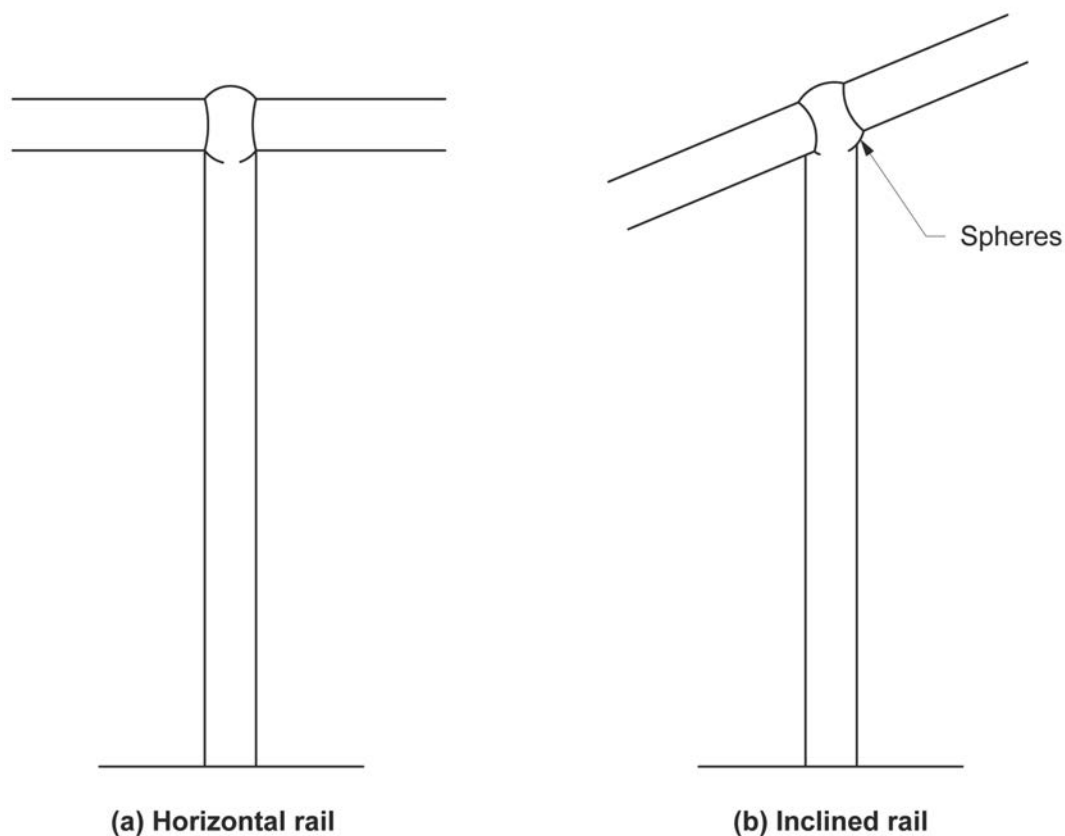

[Figure D2.17\(2\)](#) illustrates the use of handrails complying with [D2.17](#).

Figure D2.17(2) Illustration of handrails complying with D2.17 which form part of a barrier

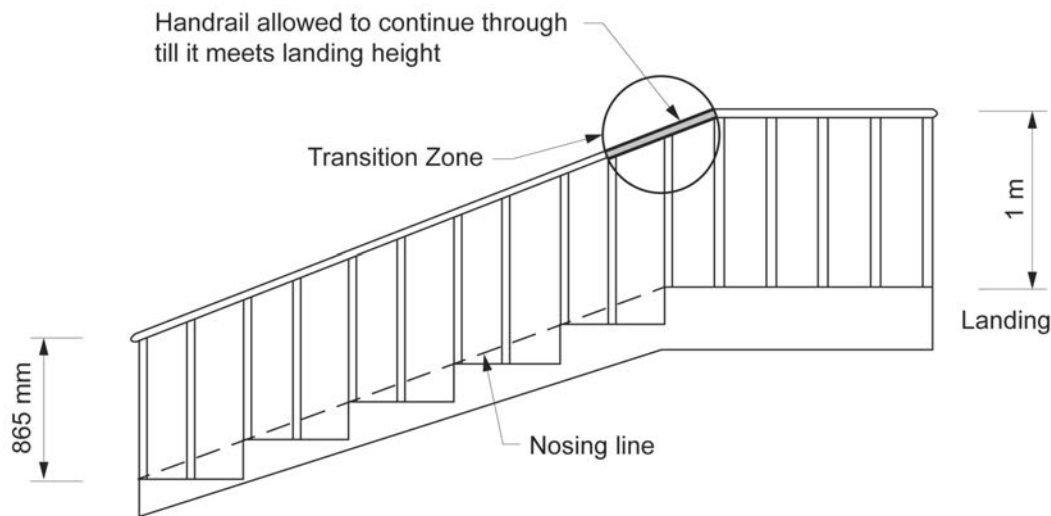

D2.18 Fixed platforms, walkways, stairways and ladders

Intent

To provide appropriate access and egress from infrequently used areas.

Reasons for different requirements

Some areas are only accessed by maintenance or specialist workers. In such areas, access and egress requirements for members of the public no longer apply, and the requirements are permitted to fall outside the various measurements applying elsewhere.

In Class 2 buildings or Class 4 parts, this includes non-habitable rooms such as attics, storerooms and the like that are not used on a frequent or daily basis. In such cases, the designer has the choice of designing the stair, landing, barrier and handrail to comply with the appropriate provisions of the NCC or with AS 1657.

D2.19 Doorways and doors

Intent

To minimise the risk that a door may obstruct a person evacuating.

D2.19 and D2.20 have the same intent

D2.19 should be read in conjunction with D2.20 because its intent is the same.

Clarification of when a doorway (or door) is “serving as (or in) a required exit”, “forming part of a required exit” or “in the path of travel to a required exit”

D2.19 refers to a “doorway serving as a required exit or forming part of a required exit”. D2.20 refers to a “door in a required exit or forming part of a required exit”. D2.21 refers to a “door in a required exit, forming part of a required exit or in the path of travel to a required exit”.

The three different terms have application to doorways and doors in three different situations described below. To understand the differences between these terms, it is necessary to understand what an exit is, as described in the definition of “exit”. Also, D1.14 Measurement of distances, provides guidance by describing when the “nearest part of an exit” includes a doorway and when it does not.

The definition of “exit” indicates that stairways (internal or external), ramps and fire isolated passageways are all exits if they provide egress to a road or open space, as are doorways opening to a road or open space and horizontal exits. Stairways and ramps that serve as exits may either be fire-isolated or non-fire-isolated, as determined by D1.3.

D1.14 describes the “nearest part of an exit” for the purpose of measuring distances (prescribed by D1.15), indicating when a doorway is considered to be part of the exit.

The nearest part of the exit is the nearest part of the doorway providing access to a fire-isolated stairway, fire-isolated passageway or fire-isolated ramp, horizontal exit, and a doorway opening to a road or open space. For a non-fire-isolated

Access and egress

stairway however, it is the nearest riser, and for a non-fire-isolated ramp, it is the nearest part of the ramped floor. The measurement to the nearest part of a doorway for a fire-isolated exit, horizontal exit and a doorway opening to a road or open space, indicates that the doorway forms part of the exit.

A “doorway serving as a required exit” or a “door in a required exit” means one that is acting as the exit itself, such as the final doorway or door—

- opening to a road or open space; or
- in a horizontal exit.

In this case, the nearest part of the doorway itself is the nearest part of an exit. The doorway or door opening to a road or open space may be a doorway or door from a space or room, or from a corridor.

A “doorway forming part of a required exit” or a “door forming part of a required exit” means a doorway or door that provides access to or is within—

- a fire-isolated stairway or ramp; or
- a fire-isolated passageway.

In this case, the nearest part of the exit is the doorway providing access to the fire-isolated stairway, ramp or passageway. Therefore, any doorway or door that leads into or out of a fire-isolated stairway, ramp or passageway is a doorway or door forming part of a required exit.

A “doorway or door in the path of travel to an exit” is a doorway or door that is not serving as, providing access into, or in, a required exit and does not form part of a required exit. It includes a doorway or door—

- opening from any space in a storey such as an office, conference room, storeroom, sanitary compartment, or the like, into a public corridor (that is not fire-isolated) or open plan public space or the like within the building, or a non-fire-isolated stairway or ramp serving as a required exit; or
- opening from one public corridor into another public corridor or public space within the building.

A doorway or door in a path of travel to an exit is any door, excluding cupboards and service openings, that a building occupant must pass through to reach the exit from the storey.

Aged care buildings—D2.19(a)

D2.19(a) applies to all doorways in resident use areas of Class 9c buildings, including doorways in paths of travel to an exit, doorways serving as required exits and doorways forming part of required exits.

Doorways within resident use areas of an aged care building must not be provided with revolving doors, roller shutter doors, tilt up doors or sliding fire or smoke doors. These types of door can impede the movement of residents and also hinder egress from the building.

Required exits and patient care areas

D2.19(b) applies only to doorways serving as a required exit, or forming part of one, and to doorways in a patient care area of a Class 9a building.

D2.19(b) does not apply to any other doorways (eg a doorway within a path of travel to an exit).

Revolving, sliding or tilt-up doors and roller shutters—D2.19(b)(i), (ii) and (iii)

Under D2.19(b)(i), (ii) and (iii), revolving, sliding or tilt-up doors and roller shutters are either prohibited or limited because of their potential to obstruct people evacuating. They can also pose problems if they fail in an emergency.

If people are impeded at a doorway, this can lead to congestion. In an extreme case, it can lead to the crushing of people as they wait for a door to open.

Concession for small Class 6–8 buildings—D2.19(b)(ii)(A)

The reason for the concession (subject to specified criteria) for roller shutters or tilt-up doors in small Class 6, Class 7 and Class 8 buildings is that the number of people in the area will be low. Note that this concession does not apply to revolving or sliding doors.

Power-operated doors—D2.19(b)(iv) and D2.19(c)

D2.19(b)(iv) sets out the requirements for power-operated doors in required exits and patient care areas.

D2.19(c) applies to power-operated doors in a path of travel to a required exit. It applies the same provisions for power-operated doors in exits or forming part of an exit contained in D2.19(b)(iv)(A) by specifying the maximum force required to open the door if there is a malfunction or power failure. The reason for this is that a door in a path of travel may also inhibit safe egress if it cannot be readily opened.

Sliding door opening force

The reference in D2.19(b)(iii)(B) and (iv)(A) to a force of 110 newtons is to a relatively small force which most people, including the elderly and the young, could reasonably be expected to use to open a door.

D2.20 Swinging doors

Intent

To minimise the risk that a door may obstruct a person evacuating.

D2.20 and D2.19 have the same intent

D2.20 should be read in conjunction with D2.19 because its intent is the same.

Required exits

D2.20 applies only to swinging doors in doorways serving as a required exit or forming part of a required exit (eg a doorway leading to, or within a fire-isolated exit). It does not apply to other doorways (eg a doorway within a path of travel to an exit).

Egress and the swing of a door—D2.20(a)

Under D2.20(a), egress from a required exit must not be impeded by the swing of a door.

The measurement of the clear width for the safe passage of people evacuating must include any door furniture, such as a door handle.

Doors into a fire-isolated exit are permitted to encroach more than 500 mm as long as they do not impede the path of travel of people already in the exit.

Figure D2.20 illustrates a method of compliance with D2.20(a).

Door must swing in the direction of egress—D2.20(b)

Under D2.20(b), doors are required to swing in the direction of egress to aid evacuation. If a door swings against the direction of egress, the first person to it may not be able to open it because of the pressure of the other people behind them. This could delay evacuation.

Concession for small buildings or parts of buildings

D2.20(b) provides a concession (under specified criteria) for small buildings or parts of buildings. The reason for allowing a door to swing against the direction of travel in such buildings is because the number of people likely to use the door will probably be low. This in turn minimises the risk caused by delays induced by opening a door towards the person attempting to gain egress.

D2.20(b)(i) requires these doors that swing against the direction of egress to be fitted with a device for holding the door in the open position. D2.20(b)(i) does not require the door to be fixed in the open position at all times that the building is legally occupied. Although this may be desirable, because of climatic conditions, the weather conditions on a particular day, or for security reasons it may not be possible or desirable for the occupants.

Hindrance—D2.20(c)

Under D2.20(c), swinging doors must not hamper occupants evacuating.

Figure D2.20 Illustration of door to a fire-isolated stairway complying with D2.20(a)

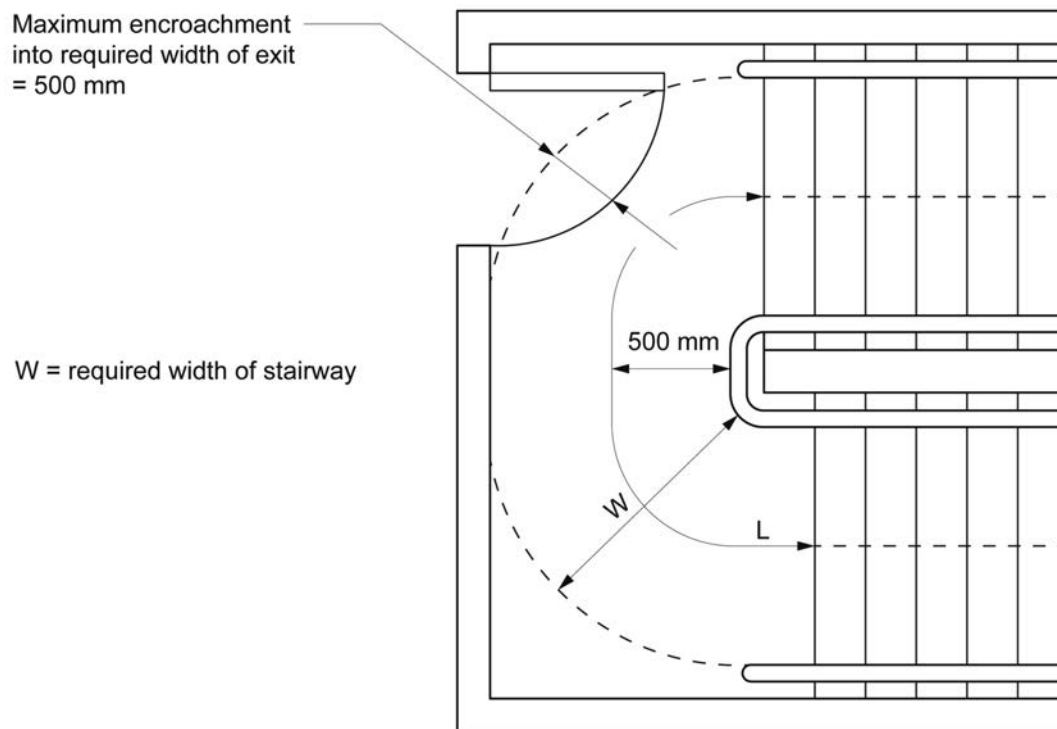

D2.21 Operation of latch

Intent

To minimise the risk that evacuation will be delayed by the operation of a door latch.

Application

D2.21 applies to all doors:

- in a required exit (eg an external doorway leading from the building);
- forming part of a required exit (eg a door leading to or within a fire-isolated exit); and
- in a path of travel to a required exit.

“Single hand downward action”

If the opening action of a door latch cannot be a pushing action, it must be a single downward action, capable of being activated with a single hand.

D2.21 prohibits the use of devices such as deadlocks and knobs (where the knobs must be operated in a twisting or similar motion).

This provision takes account of the need for an emergency opening mechanism to be operable by people with a hand or arm related disability, burns to their hands, or with perspiring or wet hands.

The height of the opening device from the floor specified in D2.21 is consistent with that contained in AS 1428.1 “Design for Access and Mobility”. This is a comfortable height for most people to use.

Ease of egress versus security

The building regulatory system principally exists to protect the safety, health and amenity of people in buildings. The safety of property, while important, is generally considered to be a secondary matter. D2.21 is designed to maximise the safety of people and prevent them being trapped within a building during a fire.

The risks to people using the building are too great to allow for the use of property security devices, such as deadlocks. Even “after hours” locks, which require human intervention (such as unlocking first thing in the morning and locking last thing at night) to allow egress during times when the public are accessing the building, are not considered to be adequately safe.

Accessible buildings

Access and egress

In accessible buildings, [D2.21\(a\)\(i\)](#) requires doors serving areas required to be accessible to have devices that prevent a hand slipping from the handle during the operation of the latch and to have a clearance of between 35 mm and 45 mm from the handle and the back plate or door face. These provisions are designed to allow use of the device by people with a disability.

D2.21 exceptions

There are several exceptions to [D2.21\(a\)](#). These include:

- [D2.21\(b\)\(i\)](#)—strongrooms and vaults, both for security purposes, and the fact that the general public would ordinarily be very unlikely to access such places;
- [D2.21\(b\)\(ii\)\(A\)](#)—sole-occupancy units within flats, because the people in the units will generally be in possession of keys to unlock the door;
- [D2.21\(b\)\(ii\)\(B\)](#)—sole-occupancy units within motels or hotels, because the people in the units will generally be in possession of keys to unlock the door. However this sub-clause does not include the entrance door to sole-occupancy units in boarding-houses, guest houses, hostels, lodging-house or backpackers accommodation as the occupant may not always have possession of keys to unlock the door;
- [D2.21\(b\)\(ii\)\(C\)](#)—small sole-occupancy units in Class 5–8 buildings, where it would be difficult to overlook the presence of anyone at closing time; and
- [D2.21\(b\)\(ii\)\(D\)](#)—restricted access spaces and rooms otherwise inaccessible to people at all times, such as cleaners' rooms and the like.

Special security arrangements—[D2.21\(b\)\(iii\)](#)

[D2.21\(b\)\(iii\)](#) provides for special arrangements to be made where particular security issues arise including Australian Government Security Zones 4 and 5. If this option is taken, the appropriate authority will need to be satisfied that, in the event of an emergency, access to exits will be enabled immediately with effectively no time delay.

Where the option for human control is exercised under [D2.21\(b\)\(iii\)\(D\)](#), the person controlling the unlocking system MUST be available at ALL times while the building is lawfully occupied. It is not acceptable for the system to be left uncontrolled. Nor is it acceptable for that person to be absent from the control post while carrying out any other work duties. A beeper or some other type of personally carried device warning of an emergency is not adequate to effect immediate opening of the locked doors. If the controlling person is absent for any reason, there must be a process enabling their relief by an equally trained person.

Fail-safe devices—[D2.21\(b\)\(iv\)](#)

[D2.21\(b\)\(iv\)](#) provides an exemption for buildings fitted with automatic “fail-safe devices”, where the devices are activated by another active system.

In this case, the appropriate authority must be satisfied that:

- the device is genuinely “fail-safe” (while not specifically referenced in [D2.21\(b\)\(iv\)](#), this would include during power failures); and
- in the event of an emergency, access to exits will be enabled immediately, with effectively no time delay.

Examples

After hours shop security may be of considerable importance, and a “fail-safe” option may be preferable to the alternative.

A special accommodation house or an institution may have residents who may be inclined to “wander”, and a “fail-safe” option may be preferable to the alternative.

D2.21 and Class 9b buildings—[D2.21\(c\)](#)

Egress from Class 9b buildings is a complex issue. They are often accessed by the general public, and include buildings which have people unfamiliar with their surroundings. This environment is not conducive to orderly or easy evacuation especially in places such as cinemas, theatres, sporting complexes and nightclubs.

[D2.21\(c\)](#) makes special provision for those which accommodate more than 100 people.

[D2.21\(c\)](#) differs from the usual [D2.21](#) provisions in that:

- it prohibits the use of a door handle type opening device (other than a bar) or other device (including levers or knobs) requiring more than a pushing action; and
- it applies to only one door leaf of a two-leaf door set. However, the other door must also swing open if it is needed to satisfy the required width of egress.

The provisions of [D2.21\(c\)](#) do not apply to schools, early childhood centres, or buildings such as churches, mosques and temples used for religious purposes. Such buildings must comply with [D2.21\(a\)](#).

Access and egress

Schools and early childhood centres are excepted because:

- the occupants are under almost constant adult supervision;
- most schools have a communication system with which occupants are familiar;
- most occupants are adequately controlled enabling easier evacuation; and
- they are used during daylight hours, and door handles and their function are more easily identified and familiar to occupants.

Testing of fire door furniture

Required fire doors must be tested as a complete unit, including the frame and furniture. The test on a fire door installed in an exit, or forming part of an exit, includes the opening devices to be used to comply with [D2.21](#).

D2.22 Re-entry from fire-isolated exits**Intent**

To minimise the risk that a person becomes trapped in a fire-isolated exit.

Facilitate entry to another exit route

It is not unknown for a fire-isolated exit to become unusable during an emergency. In high-rise buildings, hospitals and Class 9c buildings people must be able to leave the exit and proceed to an alternative exit to evacuate. It is unlikely that the second exit will also be unusable.

One option is for a person in a fire-isolated stairway to enter a storey and gain access to the alternative exit through that storey.

[D2.22\(a\)\(iii\)](#) applies to the whole fire-isolated exit serving a storey above an effective height of 25 m. This means that a fire-isolated exit serving a storey below an effective height in a building with an effective height 25 m or greater, is treated the same as one in a building with an effective height of less than 25 m, provided it does not also serve a storey that is located above an effective height of 25 m.

It should be noted that if a fire-isolated passageway serves two stairways, one of which serves a storey above an effective height of 25 m, then [D2.22\(a\)\(iii\)](#) will apply, i.e. the doors cannot be locked from the inside.

Example

Consider a building consisting of a 5 storey podium and a main tower with an effective height greater than 25 m. Any fire-isolated stairway and associated fire-isolated passageway serving the tower must not have doors locked from within the exit. However, because the storeys in the podium are below an effective height greater than 25 m, any fire-isolated stairway and associated fire-isolated passageway that only serves those storeys may have a door locked from within the exit.

See [Figure D2.22](#).

Access and egress

Figure D2.22 Illustration of exits serving storeys above and below an effective height of 25 m

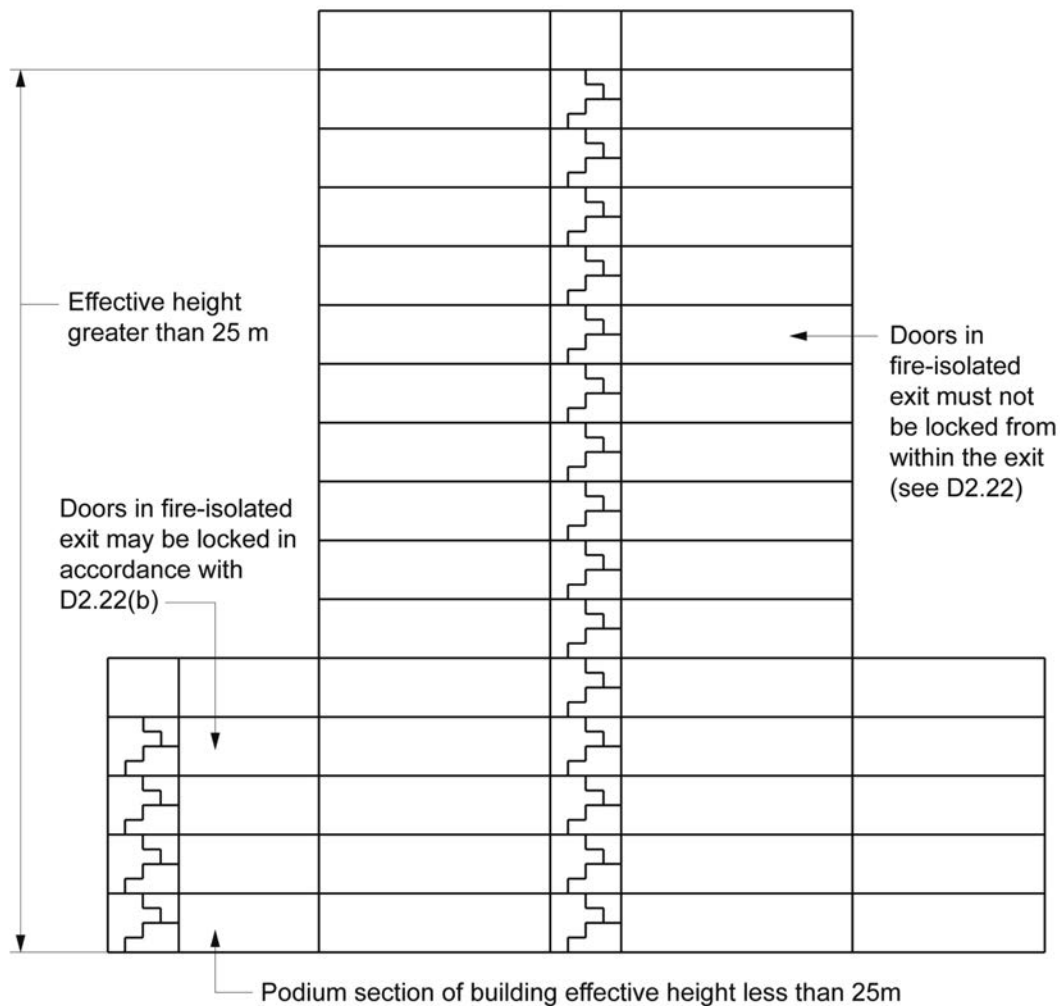
**Mistaken entry**

Under normal conditions of use, it is also possible that a person may mistakenly enter a fire-isolated exit. That person should not be required to travel all the way down the stairway to be able to leave it, especially in a high-rise or Class 9c building.

Every fourth storey re-entry

The ability to enter at each floor of a building could be unnecessary and lead to a breach of a building's security. Accordingly, entry at every fourth floor (under [D2.22\(b\)\(i\)](#)) will achieve the intent of this provision, without significantly interfering with the building's security. Where this option is taken, all doors must be operable by a fail-safe device activated by a fire alarm.

Intercommunication systems

An alternative method of minimising the risk of a person being trapped in a fire-isolated stairway is to provide an intercommunication system under [D2.22\(b\)\(ii\)](#). Where this option is taken, all doors must be operable by a fail-safe device activated by a fire alarm.

D2.23 Signs on doors**Intent**

To require the use of signs warning against impairing certain doors.

Blocked doors

The doors referred to in [D2.23\(a\)](#) are all required for evacuation in an emergency. Their obstruction could result in the death of people attempting to evacuate.

Open doors

Fire and smoke doors are designed to minimise the risk to people inside a fire compartment and a fire-isolated exit. A door kept open in a storey experiencing a fire could result in the emergency exit becoming unusable, or could aid the spread of fire and/or smoke to other parts of the building. If all exits are affected, people will have no way of evacuating the building.

D2.24 Protection of openable windows

Intent

To limit the risk of a person (especially a young child) falling through an openable window.

Design solutions

The intent of [D2.24](#) is to limit the risk of a person (especially a young child) falling through an openable window. Where the floor level below an openable window is less than 2 m there are no specific requirements. For an openable window in a bedroom of a Class 2 or 3 building or Class 4 part of a building or in a Class 9b early childhood centre 2 m or more above the surface beneath, openable windows are required to restrict the passage of a 125 mm sphere using any one of the following design solutions:

- The window be designed such that any opening does not allow a 125 mm sphere to pass through (e.g. louvres).
- The window be fitted with a fixed or dynamic device that is capable of restricting the window opening so it does not allow a 125 mm sphere to pass through and is difficult for a young child to operate. The restricting device must be capable of resisting a 250 N force when directed against the window such as a casement window or in attempting to push a sliding window open. An internal screen with similar parameters may be installed.
- The window be fitted with an internal or external screen that does not allow a 125 mm sphere to pass through and which must resist a horizontal outward force of 250 N.

If the openable part of a window is at least 1.7 m above the floor, no further protection is required.

[D2.24\(b\)\(ii\)\(C\)](#) relates to a screen or window restricting device protecting an openable window in a bedroom of a Class 2 or 3 building or Class 4 part of a building or in a Class 9b early childhood centre. The screen or opening restricting device may be installed in a manner that allows it to be removed, unlocked or overridden in the event of a fire or other emergency to allow safe egress. In these situations the unlocking device must be child resistant.

Child resistance could be achieved through the use of a tool, key or two hands.

There are a number of hardware options available. Short chain winders and barrier screens will allow windows to comply with this requirement. Sliding window locks may lock a sash so a 125 mm sphere cannot pass through. Where provision is made to fully open the window beyond 125 mm then the child resistant release mechanism is required in addition to the device resisting a 250 N force as required by [D2.24\(b\)\(ii\)\(B\)](#).

[D2.24\(c\)](#) in addition prescribes that an 865 mm barrier (sill) would be required. A wall beneath an openable window can be considered as the barrier if the criteria in [\(d\)](#) are met.

[D2.24\(c\)\(ii\)](#) relates to the height of a barrier under an openable window that is not in a bedroom in a Class 2 or 3 building or a Class 4 part of a building.

The term 'window' is not italicised in [D2.24](#) and as such, is not restricted to the definition of 'window' in the NCC. The reason for this is to also capture windows that may let in air but not light, e.g. metal louvres. A metal louvre or openable panel would not fit in the NCC definition of window but is subject to the window barrier provisions.

D2.25 Timber stairways: Concession

Intent

To provide a concession to [D2.2](#) for timber stairways.

[D2.2](#) sets the criteria for the materials and methods of construction used in stairways and ramps within a fire-resisting shaft. The provision provides requirements for maintaining the integrity of the fire protection to the shaft of a fire-isolated stairway and ramp, by requiring a stairway or ramp to be constructed of non-combustible materials to ensure that if there is local failure it will not impair the fire-resistance of the shaft.

[D2.25](#) provides a concession to the requirements of [D2.2](#) allowing timber treads, risers, landings and associated supporting framework to be used within a fire-isolated stairway or fire-isolated passageway constructed of fire-protected timber provided:

- the timber treads, risers, landings and associated supporting framework meets certain material requirements;
- the building is provided with a sprinkler system (including within the fire-isolated stairway or passageway); and

Access and egress

- 13 mm fire-protective grade plasterboard is installed to the underside of flights and landings located directly above a landing level which is at or near the level of egress or provides direct access to car parking levels.

[D2.25](#) applies to a fire-isolated stairway or fire-isolated passageway constructed of fire-protected timber, therefore the limitations of [C1.13](#) apply. These limitations include a maximum effective height of 25 m and application only to Class 2, 3 and 5 buildings.

Part D3 Access for people with a disability

Objective

Functional Statements

Performance Requirements

The Objective and Functional Statements for [Section D](#) are at the beginning of [Section D](#) of this Guide. The Performance Requirements for [Section D](#) precede [Part D1](#).

Deemed-to-Satisfy Provisions

D3.0 Deemed-to-Satisfy Provisions

Intent

To clarify that the requirements of [DP1](#) to [DP6](#), [DP8](#) and [DP9](#) will be satisfied if compliance is achieved with [Parts D1](#), [D2](#) and [D3](#) in the case of all buildings, [Part G3](#) in the case of buildings with an atrium, [Part G4](#) in the case of buildings in alpine areas, [Part H1](#) in the case of theatres, stages and public halls, and [Part H2](#) for public transport buildings. [DP7](#) is only required to be complied with if lifts are to be used to assist occupants to evacuate.

See comments under [D1.0](#). They apply here.

D3.1 General building access requirements

Intent

To specify when access for people with a disability must be provided to buildings and parts of buildings.

Extent of access within buildings

The extent of access required depends on the classification of the building. Buildings and parts of buildings must be accessible as set out in [Table D3.1](#) unless exempted by [D3.4](#).

Class 1b buildings

While access requirements do not apply to Class 1a buildings (typically a detached house, town house or terrace house), they do apply to certain Class 1b buildings used for short-term holiday accommodation such as cabins in caravan parks, tourist parks, farm stay, holiday resorts and similar tourist accommodation. This accommodation itself is typically rented out on a commercial basis for short periods and generally does not require the signing of a lease agreement. Short-term accommodation can also be provided in a boarding house, guest-house, hostel, bed and breakfast accommodation or the like.

Where four or more dwellings used for short-term holiday accommodation on the same allotment are constructed or upgraded, a ratio of accessible dwellings is required. Where there is a newly constructed single Class 1b building, [Table D3.1](#) requires that access be provided to and within at least one bedroom, at least one of each type of room or space for use in common by residents, and to and within all rooms or spaces for use in common on floors served by a lift or accessible ramp.

Class 2 buildings

While the access provisions do not apply to the internal parts of sole-occupancy units, [Table D3.1](#) does require that the common areas on one floor containing sole-occupancy units and at least one of each type of common area such as a games room or gymnasium be accessible. Where a lift or accessible ramp serves other levels, common areas on the levels served must also be accessible. There is no requirement to make private areas provided for the exclusive use of a limited number of residents accessible. For example, a roof top tennis court or spa that is only available to the penthouse suite is not required to be accessible.

Class 3 buildings

[Table D3.1](#) requires that the common areas on one floor containing sole-occupancy units be accessible. Where a lift or accessible ramp serves other levels, common areas on the levels served must also be accessible. [Table D3.1](#) also requires access to be provided to at least one of each type of room or space used in common by the residents, such as TV lounges and dining rooms. For example, a two storey Class 3 building need not have the upper storey accessible so long as there

Access and egress

is no unique room or space available to all residents on the upper storey and that upper storey is not served by a lift or accessible ramp.

A ratio of accessible sole-occupancy units is required. Where more than 2 accessible sole-occupancy units are required in a Class 3 building, they are to be representative of the range of rooms available, taking into account amenity and pricing. For example, in a large hotel required to have 10 accessible rooms, the rooms must be distributed to provide a variety of views, proximity to features and price ranges. No more than 2 accessible sole-occupancy units can be located adjacent to each other. When there is more than one accessible sole-occupancy unit, alternate left and right-handed sanitary facilities must be provided in the accessible sole-occupancy units. This ensures the availability of choice for people who, for example, need to transfer from a wheelchair from one side or the other.

Class 5, 6, 7b, 8 and 9a buildings

[Table D3.1](#) requires that access be provided to all areas within the building normally used by the occupants, with the exception of those areas that are exempted by [D3.4](#). The term “occupants” refers to any person using the building including visitors, employees, employers and owners.

Class 7a carpark

Access must be provided to any level containing accessible carparking spaces.

Class 9b buildings

Access must be provided to all areas normally used by the occupants with the exception of those areas that are exempted by [D3.4](#). In an assembly building other than a school or an early childhood centre, access need not be provided to tiers or platforms containing seating areas if no wheelchair seating spaces are provided on those levels.

Wheelchair seating spaces must be provided in locations that are representative of the fixed seating locations provided. Wheelchair seating spaces must be located to take into account amenity, proximity to facilities, available sightlines and pricing. It would not be acceptable in a Class 9b building in which fixed seating is provided to have all wheelchair seating spaces provided in a single location. In the case of assembly buildings such as theatres and concert halls, areas used by the occupants include change rooms, offices, orchestra pits, stages or the like.

Some Class 9b buildings may be public transport buildings. The passenger use areas of these buildings may be subject to [Part H2](#) in addition to the general access provisions.

Class 9c buildings

The BCA access provisions and AS 1428.1 are focussed on the needs of people with a disability and not specifically aged persons. For this reason, the access provisions of AS 1428.1 have not been applied to all sole-occupancy units in Class 9c buildings but only to those specific rooms that are required to be provided for people with a disability. The extent of access to be provided in Class 9c buildings is similar to that for Class 3 buildings.

Class 10 buildings

Certain Class 10a buildings such as a toilet block in a park, a public structure for the purpose of providing shelter, or change rooms associated with a sports field are required to be accessible if they are located in an accessible area. Generally, these facilities would be close to a carpark or at the beginning of a walkway. However, in some circumstances, a Class 10a building may be a considerable way into a nature walk where it may not be possible to provide an accessible path of travel. In such cases the Class 10a buildings need not be accessible.

Where a Class 10b swimming pool is a public pool such as a health centre pool, Council pool or a common use pool associated with a Class 3 building, and has a perimeter measured at the water’s edge of more than 40 metres, [Table D3.1](#) requires at least one form of entry for people with a disability. Methods for accessing a swimming pool can be found in [D3.10](#).

Some Class 10 buildings may be public transport buildings (for example an open railway platform). The passenger use areas of these buildings may be subject to [Part H2](#) in addition to the general provisions.

D3.2 Access to buildings

Intent

To specify the extent of access for people with a disability that must be provided.

[D3.2\(a\)](#) requires accessways to be provided to accessible buildings from the main points of a pedestrian entry at the allotment boundary and from any accessible car parking space or accessible associated buildings connected by a pedestrian link.

In [D3.2\(b\)](#) the principal pedestrian entrance is to be accessible in all cases and not less than 50% of all pedestrian entrances, including the principal pedestrian entrance, are to be accessible. In buildings with a total floor area more than 500 m², an inaccessible entrance cannot be more than 50 m from an accessible entrance. This ensures that situations where people have to travel an unreasonable distance between entrances are avoided. An entrance that serves only an

Access and egress

area exempted by [D3.4](#) need not be accessible.

The principal pedestrian entrance is required to be accessible in all cases because it would be the most commonly used entrance by all building users. This is particularly important in public buildings where the principal entrance is often used as a focus for events or as a ceremonial entrance, particularly in hotels and theatres.

Designers should consider the proximity of ramps or lifting devices to stairs or steps at an entrance. People who require a ramp or lifting device at an entrance should not have to travel significantly greater distances to use the entrance than people without a disability.

Similarly, for convenience, the ramp or lifting device should be located as close as possible to any vehicular drop off point or taxi rank servicing a building entrance.

Where an entrance has multiple doorways, the BCA does not require all of them to be accessible:

- If an entrance doorway is manually operated, the minimum dimensions required to provide access must be provided by the opening of a single leaf, so that a person with a disability only has to negotiate their entry through one door leaf.
- If the doorway is automatically operated, the minimum dimension can be provided using two leaves.

D3.3 Parts of buildings to be accessible

Intent

To specify the requirements for accessways within buildings which must be accessible.

In most buildings, access is to be provided to all parts of the building normally used by the occupants with the exception of areas exempted by [D3.4](#). However, it is not intended that access for people who use wheelchairs be provided within non-accessible sanitary facilities or non accessible sole-occupancy units.

Similarly, although stairways are not allowed on an accessway, they are allowed on other paths of travel. The specified provisions of AS 1428.1 provide technical information on how stairways and ramps are to be made safe and accessible for people with an ambulant disability or vision impairment. It is important to note that different requirements are specified for fire-isolated stairways and ramps and other stairways and ramps.

[D3.3\(c\)\(i\)](#) covers passing spaces on accessways to ensure that a person does not have to retrace their journey for an unreasonable distance to pass another person if the accessway is not sufficiently wide for passing to occur at any point. The minimum dimensions for a passing space are contained in AS 1428.1. Space for passing to occur need only be provided where there is not a direct line of sight to the end of the accessway.

[D3.3\(c\)\(ii\)](#) covers turning spaces on accessways to ensure that a person does not have to reverse for an unreasonable distance if they encounter a dead-end or need to retrace their journey. The minimum dimensions for a turning space are contained in AS 1428.1. Turning spaces are required within 2 metres of the end of an accessway if it is not possible to continue to travel along the accessway, and at least every 20 metres along an accessway whether or not there is a direct line of sight.

In [D3.3\(d\)](#) and [\(e\)](#) a passing space may also serve as a turning space and the circulation space required at an intersection of accessways is sufficient for passing or turning to occur. In this situation a dedicated passing or turning space would not be required at those locations.

Some storeys or levels, other than the entrance storey, in certain small buildings are not required by [D3.3\(f\)](#) to be provided with access via a passenger lift or a ramp complying with AS 1428.1. This exemption applies only to Class 5, 6, 7b and 8 buildings with 2 or 3 storeys (that is a building with 1 or 2 storeys in addition to the entrance level). This could be a building with 1 or 2 storeys above the entrance level or below it. The exemption states that if the size of each storey (other than the entrance level) is less than 200 m² access via a passenger lift or ramp complying with AS 1428.1 is not required to the other levels. However, if the entrance level to a 3 storey building was 600 m², the 1st storey was also 600 m² and the 2nd storey was only 150 m², access would be required via a passenger lift or ramp complying with AS 1428.1 to all levels. Even though access via a ramp or lift is not required to certain storeys or levels, all other accessible features required by the BCA, except accessible unisex sanitary compartments and accessible unisex showers (see [F2.4\(i\)](#)), are required on the non-entrance levels.

D3.4 Exemptions

Intent

To provide exemptions to the Deemed-to-Satisfy Provisions for access by people with a disability.

This provision provides details on buildings or parts of buildings not required to be accessible under the BCA. [D3.4](#) details exemptions to the requirements for access to certain areas within buildings where providing access would be inappropriate

Access and egress

because of the nature of the area or the tasks undertaken. These areas could include rigging lofts, waste containment areas, foundry floors, loading docks, fire lookouts, Class 8 electricity network substations, plant and equipment rooms and other similar areas. Assessment of these areas is on a case-by-case basis.

While these areas may be assessed as not required to be accessible, nothing in the BCA prevents a designer from providing greater access than the required provisions, should they desire to do so.

D3.5 Accessible carparking

Intent

To clarify the minimum Deemed-to-Satisfy Provisions for accessible carparking.

Table D3.5 provides details of the number of accessible carparking spaces required in a carpark depending on the classification of the building and based on the ratio of the total number of carparking spaces provided. If the carpark serves a multi-classified building, the number of accessible carparking spaces required should be calculated by determining the number of spaces serving each of the classifications. The specifications for accessible carparking spaces, contained in AS/NZS 2890.6, aim to maximise the area available to people with a disability to get into and out of their vehicles. However:

- while at least one carparking space complying with AS/NZS 2890.6 is required in any carpark covered by **D3.5**, signage and markings designating an accessible carparking space are only required in a carpark with more than a total of 5 spaces; and
- accessible carparking spaces are not required in a carpark where carpark users do not park their own vehicles, such as a carpark that has a valet parking service.

The most appropriate location for the accessible car parking spaces will be, to some extent, determined by the use and function of the building. For example, a carpark associated with a cinema might have the accessible carparking spaces as close as possible to the main pedestrian entrance and ticketing area.

It may be more appropriate in a building with multiple pedestrian entrances, such as a shopping centre, to distribute accessible carparking spaces to ensure that the distance between the accessible car parking spaces and the entrances to the buildings are minimised.

D3.6 Signage

Intent

To assist people with a disability to easily identify the facilities, services, exits and features provided in a building.

D3.6 provides requirements for signage in buildings required to be accessible by **Part D3**. Signage is only required by **Part D3** in particular situations.

D3.6(a)(i) provides that all sanitary facilities, except those within a bedroom of a Class 1b building or a sole-occupancy unit in a Class 3 building, and any space with a hearing augmentation system, must have braille and tactile signage compliant with **Specification D3.6** that incorporates the international symbol for access or deafness, as appropriate, in accordance with AS 1428.1. Signage in accordance with AS 1428.1 must also identify any ambulant accessible sanitary facilities and must be located on the door of the ambulant accessible compartments.

D3.6(a)(ii) provides that each door required by **E4.5** to be provided with an exit sign, must have braille and tactile signage compliant with **Specification D3.6** that states "Exit", "Level" and either:

- the floor level number;
- a floor level descriptor; or
- a combination of the above.

All signage required by **D3.6(a)(ii)** must state "Exit" and "Level", however there is some flexibility about how to describe the "Level". For example, "Ground Level", "Level 1" and "Basement Level 1" are all appropriate descriptions.

D3.6(b) provides that signage including the international symbol for deafness in accordance with AS 1428.1 must be provided in a room with a hearing augmentation system. The signage must indicate the type of hearing augmentation, and the area of the room covered. Signage must also indicate if receivers are used in the room, and where they may be obtained if this is the case.

D3.6(c) applies in addition to **D3.6(a)(i)**.

D3.6(c) requires each standard unisex accessible sanitary facility that is required by **Table F2.4(a)**, to have signage indicating whether the facility allows for left or right handed transfer.

D3.6(e) and **D3.6(f)** provide that directional information including the international symbol of access must be provided at

Access and egress

any pedestrian entrance that is not accessible or a bank of sanitary facilities that does not include a unisex accessible sanitary facility. The directional information must identify where the nearest accessible entrance or accessible sanitary facility can be found.

[D3.6\(g\)](#) applies to any building in which an accessible adult change facility is installed. It requires that directional signage be provided at each standard accessible sanitary compartment to indicate the way to the nearest one that includes an accessible adult change facility.

D3.7 Hearing augmentation

Intent

To assist people with a hearing impairment to be made aware of communications associated with a building's use.

[D3.7](#) provides requirements for provision of hearing augmentation systems in accessible buildings. There are a number of hearing augmentation systems available. A decision on which system to use will depend on a number of factors, such as the size and use of the space, external interferences and building materials used.

Hearing augmentation coverage is not required to 100% of the floor area of rooms because such coverage could spill over into adjoining rooms and affect the operation of the system installed in those rooms, and because design considerations such as interference and building design mean that it is difficult to ensure complete coverage in any room.

[D3.7\(a\)](#) provides that hearing augmentation systems must be provided where an inbuilt amplification system is provided (other than one only used for emergency warning) in a room in a Class 9b building, in certain types of rooms such as auditoriums, conference rooms, and at ticket offices, teller's booths, reception areas and similar areas where the public is screened from the service provider.

[D3.7\(b\)](#) sets out requirements for hearing augmentation systems where they are required under [D3.7\(a\)](#). Requirements for hearing augmentation can be met by use of either an induction loop, or the use of receivers or similar systems. Where an induction loop is provided, it must cover at least 80% of the floor area of the room or space that is served by the inbuilt amplification system.

For hearing augmentation systems using audio receivers, the system must cover at least 95% of the floor area of the room or space served by the inbuilt system, and a minimum number of receivers must be provided in a ratio depending on the number of people who may be accommodated in the room (calculated by reference to [D1.13](#)).

[D3.7\(d\)](#) provides that screens or scoreboards associated with a Class 9b building that are capable of displaying public announcements must be capable of supplementing any public address system (other than a public address system used for emergency warning purposes only).

D3.8 Tactile indicators

Intent

To assist blind or vision impaired people to avoid hazardous situations.

Warning Tactile Ground Surface Indicators (TGSIs) are intended only to be used for specific hazard identification in those areas identified within [D3.8](#). This includes:

- at the top and bottom of stairways, escalators and ramps except those only leading to areas exempted under [D3.4](#); and
- where there is an overhead obstruction less than 2 m above the floor along the pathway, in the absence of a suitable barrier that would prevent a person from hitting the overhead obstruction.

[D3.8\(c\)](#) permits raised dome buttons on handrails as an alternative in some aged care buildings. The reason for the alternatives in aged care buildings is that ground surface indicators may hinder people using walking frames or the like.

Note that TGSIs are not required on enclosed landings between flights of stairs where no other entrance/exit leads onto/off the landing.

The specifications for TGSIs are contained in sections 1 and 2 of AS 1428.4.1.

D3.9 Wheelchair seating spaces in Class 9b assembly buildings

Intent

To specify the requirements for wheelchair seating spaces in Class 9b assembly buildings.

[D3.9](#) provides requirements for the provision of wheelchair seating spaces in Class 9b assembly buildings. This includes the number of wheelchair seating spaces to be provided in theatres, cinemas and the like, their positioning within the

Access and egress

general seating area and how they are to be grouped with other seats or wheelchair spaces. The dimensions of wheelchair seating spaces must comply with AS 1428.1.

[Table D3.9](#) provides requirements relating to the number and permissible grouping of wheelchair seating spaces, depending on the number of fixed seats in the room or space. Grouping all wheelchair spaces together potentially limits the seating options for family or friends accompanying a person using a wheelchair, so requirements are included that spaces be provided both singly and in groups. Wheelchair seating spaces may be provided by having removable seats so that, if the wheelchair spaces are not required, seats for other patrons can be installed in those locations. However, building managers would need to ensure that management practices in relation to removable seating do not discriminate.

[D3.9\(b\)](#) imposes additional requirements on wheelchair seating spaces in cinemas. In cinemas of less than 300 seats, wheelchair seating spaces must not be provided in the front row of seats. In cinemas with more than 300 seats, not less than 75% of required wheelchair seating spaces must be located in rows other than the front row. The location of wheelchair seating spaces must be representative of the range of seating provided.

D3.10 Swimming pools

Intent

To specify the requirements for accessible swimming pools.

[D3.10](#) provides the requirements for making swimming pools accessible to people with a disability. Swimming pools, required by [Table D3.1](#) to be accessible, must provide not less than one means of accessible water entry and exit in accordance with [Specification D3.10](#).

[Table D3.1](#) requires that swimming pools with a perimeter greater than 40 m be accessible if they are associated with a building required to be accessible. Private swimming pools are not required to be accessible.

[D3.10\(b\)](#) provides the means by which accessible water entry and exit may be provided. [D3.10\(c\)](#) provides that where a swimming pool has a perimeter of more than 70 m, entry must be provided by at least one of the following: a fixed or movable ramp and an aquatic wheelchair, a zero depth entry and an aquatic wheelchair, or a platform style swimming pool lift and an aquatic wheelchair. Accordingly, only swimming pools of less than 70 m in perimeter may provide a sling-style swimming pool lift as the sole means of water entry and exit.

Under [D3.10\(d\)](#) latching devices on gates and doors which form part of a swimming pool safety barrier need not comply with AS 1428.1.

D3.11 Ramps

Intent

To specify the requirements for ramps forming part of an accessway.

Ramps may be used as part of an accessway where there is a change in level. The ramp must comply with the requirements specified in AS 1428.1 including a maximum gradient, landings, TGSIs, handrails and kerbing, as appropriate for the type of ramp.

A ramp cannot be used on an accessway to connect one level to another if the vertical rise is greater than 3.6 metres. This is to ensure that the ramp does not cause undue fatigue for a user to the point where the ramp becomes unusable.

Where a ramp is installed on a path of travel used solely for servicing an area exempted under [D3.4](#) the requirements of AS 1428.1 are not mandatory.

D3.12 Glazing on an accessway

Intent

To specify the requirements for glazing within an accessway.

This provision requires there to be a contrasting strip, chair rail, handrail or transom across all frameless or fully glazed doorways and surrounding glazing capable of being mistaken for an opening. The purpose of this requirement is to assist a person who has a vision impairment to be able to identify the presence of the glazing and avoid injury caused by contact with the glazing. A contrasting strip with a series of dots, unconnected patterns or shapes that do not provide high levels of contrast would not meet the requirements of this provision.

Specification D1.12

Non-required stairways, ramps and escalators

Deemed-to-Satisfy Provisions

This Guide does not address every provision in this Specification. However, there are more comments which should be made:

Purpose of [Specification D1.12](#)

[Specification D1.12](#) establishes requirements for the construction and installation of stairways, ramps and escalators not required by the BCA, and which are not fire-isolated. These requirements aim to prevent the spread of fire through an unrestricted number of floors through unprotected openings for stairways, ramps and escalators.

Consistency with atrium requirements

[Specification D1.12](#) is consistent with the provisions of [Part G3](#), which, without imposing additional requirements, allows an atrium to connect two non-sprinkler protected storeys or three sprinkler protected storeys.

Need for fire shaft

There does not yet appear to be a practical method of applying this Specification without the construction of a fire shaft. Such a shaft provides the necessary fire separation between the floors. Its construction is similar to that of a fire-isolated stairway shaft.

Specification D3.6**Braille and tactile signs****Deemed-to-Satisfy Provisions****1 Scope****Intent**

To clarify that [Specification D3.6](#) provides the design and installation details for braille and tactile signs.

2 Location of braille and tactile signage

This clause provides requirements for the location of braille and tactile signs. The correct placement of braille and tactile signs is important in ensuring that they are able to be used. [Clause 2](#) describes where required signs are to be located accounting for the range of a person's reach and sight lines. Where possible, signs are not to be placed on doors, to avoid the hazard of a door being opened onto a person attempting to read the sign.

3 Braille and tactile sign specification

[Clause 3](#) provides specifications for braille and tactile signs to ensure a consistent approach is used and to ensure that the signage is usable.

4 Luminance contrast

[Clause 4](#) provides requirements for luminance contrast for braille and tactile signs. Luminance contrast is the amount of light reflected from one surface or component, compared to the amount of light reflected from the background or surrounding surfaces. Specifying a minimum luminance contrast between signs and the surface they are mounted on and between a sign and its characters, assists people with a vision impairment in finding and accessing information on signs.

5 Lighting

[Clause 5](#) provides that sufficient illumination of signs must be available to ensure that the level of luminance contrast is achieved at times when the sign is required to be read.

6 Braille

[Clause 6](#) provides specifications for braille used on signs to ensure that signage is consistent and usable.

Specification D3.10

Accessible water entry/exit for swimming pools

Deemed-to-Satisfy Provisions

1 Scope**Intent**

To clarify that [Specification D3.10](#) provides the design and installation details for accessible water entry/exit for swimming pools. [Specification D3.10](#) must be read in conjunction with [D3.10](#).

2 Fixed or moveable ramp

[Clause 2](#) provides specifications for fixed and moveable ramps, which are allowed as a method of water entry and exit by [D3.10\(b\)\(i\)](#), in conjunction with an aquatic wheelchair as described in [Clause 6](#).

3 Zero depth entry

[Clause 3](#) provides specifications for zero depth entries, which are allowed as a method of water entry and exit by [D3.10\(b\)\(ii\)](#), in conjunction with an aquatic wheelchair as described in [Clause 6](#). The term 'zero depth entry' is used to describe entry into a pool that provides a gentle gradient into the water not exceeding 1:14.

4 Platform swimming pool lift

[Clause 4](#) provides specifications for platform swimming pool lifts, which are allowed as a method of water entry and exit by [D3.10\(b\)\(iii\)](#), in conjunction with an aquatic wheelchair as specified in [Clause 6](#). A platform swimming pool lift consists of a platform onto which an aquatic wheelchair is wheeled. The platform is then raised, positioned over the water and then lowered into the water.

5 Sling-style swimming pool lift

[Clause 5](#) provides specifications for sling-style swimming pool lifts, which are allowed as a method for water entry and exit by [D3.10\(b\)\(iv\)](#), but which may only be the sole method of water entry for swimming pools with a perimeter of less than 70 m ([D3.10\(c\)](#)). A sling-style swimming pool lift is used to assist in transferring a person directly from their wheelchair. The person in the wheelchair may position themselves into the sling when detached from the lifting device. This allows the person to transfer by the poolside or in the privacy of a changing area. The sling is then attached to the lifting device and the person is transferred into the pool without their wheelchair.

6 Aquatic wheelchair

[Clause 6](#) provides specifications for aquatic wheelchairs to ensure their suitability for use for water entry and exit. An aquatic wheelchair is used in conjunction with a fixed or movable ramp, a zero depth entry and a platform swimming pool lift. An aquatic wheelchair is designed to be used and immersed in water and is usually constructed of plastic or a similar material that does not react adversely when exposed to water.

Services and equipment

- Part E1** **Fire fighting equipment**
- Part E2** **Smoke hazard management**
- Part E3** **Lift installations**
- Part E4** **Visibility in an emergency, exit signs and warning systems**

Section E Services and equipment

Part E1 Fire fighting equipment

Objective

EO1

Functional Statements

EF1.1

Performance Requirements

EP1.1 Fire hose reels

EP1.2 Fire extinguishers

EP1.3 Fire hydrants

EP1.4 Automatic fire suppression systems

EP1.5 Firefighting services in buildings under construction

EP1.6 Fire control centres

Deemed-to-Satisfy Provisions

E1.0 Deemed-to-Satisfy Provisions

E1.1 * * * * *

E1.2 * * * * *

E1.3 Fire hydrants

E1.4 Fire hose reels

E1.5 Sprinklers

E1.6 Portable fire extinguishers

E1.7 * * * * *

E1.8 Fire control centres

E1.9 Fire precautions during construction

E1.10 Provision for special hazards

Specification E1.5 Fire sprinkler systems

Deemed-to-Satisfy Provisions

1 Scope

2 Application of automatic fire sprinkler standards

3 Separation of sprinklered and non-sprinklered areas

4 Protection of openings

5 Fast response sprinklers

6 Sprinkler valve enclosures

7 Water supply

8 Building occupant warning system

9 Connection to other systems

10 Anti-tamper devices

11 Sprinkler systems in carparks

12 Residential care buildings

Specification E1.8 Fire control centres

Deemed-to-Satisfy Provisions

1 Scope

2 Purpose and content

3 Location of fire control centre

4 Equipment not permitted within fire control centre

5 Ambient sound level for a fire control centre

6 Construction of fire control room

7 Protection of openings in a fire control room

8 Doors to a fire control room

9 Size and contents of a fire control room

- 10 Ventilation and power supply for a fire control room
- 11 Sign for a fire control room
- 12 Lighting for a fire control room

Part E2 Smoke hazard management

Objective

EO2

Functional Statements

EF2.1

Performance Requirements

EP2.1 Automatic warning for sleeping occupants

EP2.2 Safe evacuation routes

Deemed-to-Satisfy Provisions

E2.0 Deemed-to-Satisfy Provisions

E2.1 Application of Part

E2.2 General requirements

E2.3 Provision for special hazards

Specification E2.2a Smoke detection and alarm systems

Deemed-to-Satisfy Provisions

1 Scope

2 Type of system

3 Smoke alarm system

4 Smoke detection system

5 Combined smoke alarm and smoke detection system

6 Smoke detection for smoke control systems

7 Building occupant warning system

8 System monitoring

Specification E2.2b Smoke exhaust systems

Deemed-to-Satisfy Provisions

1 Scope

2 Smoke exhaust capacity

3 Smoke exhaust fans

4 Smoke reservoirs

5 Smoke exhaust fan and vent location

6 Make-up air

7 Smoke exhaust system control

8 Smoke detection

Specification E2.2c Smoke-and-heat vents

Deemed-to-Satisfy Provisions

1 Adoption of AS 2665

2 Controls

Part E3 Lift installations

Objective

EO3

Functional Statements

EF3.1

EF3.2

EF3.3

Performance Requirements

EP3.1 Stretcher facilities

EP3.2 Emergency lifts

- EP3.3 Emergency alerts
- EP3.4 Lift access for people with a disability

Verification Methods

- EV3.1 Fire Safety Verification Method

Deemed-to-Satisfy Provisions

- E3.0 Deemed-to-Satisfy Provisions
- E3.1 Lift installations
- E3.2 Stretcher facility in lifts
- E3.3 Warning against use of lifts in fire
- E3.4 Emergency lifts
- E3.5 Landings
- E3.6 Passenger lifts
- E3.7 Fire service controls
- E3.8 Residential care buildings
- E3.9 Fire service recall control switch
- E3.10 Lift car fire service drive control switch

Specification E3.1 Lift installations**Deemed-to-Satisfy Provisions**

- 2 Lift cars exposed to solar radiation

Part E4 Visibility in an emergency, exit signs and warning systems**Objective**

- EO4

Functional Statements

- EF4.1

Performance Requirements

- EP4.1 Visibility in an emergency
- EP4.2 Identification of exits
- EP4.3 Emergency warning and intercom systems

Verification Methods

- EV4.1 Emergency Lighting

Deemed-to-Satisfy Provisions

- E4.0 Deemed-to-Satisfy Provisions
- E4.1 * * * * *
- E4.2 Emergency lighting requirements
- E4.3 Measurement of distance
- E4.4 Design and operation of emergency lighting
- E4.5 Exit signs
- E4.6 Direction signs
- E4.7 Class 2 and 3 buildings and Class 4 parts: Exemptions
- E4.8 Design and operation of exit signs
- E4.9 Emergency warning and intercom systems

Specification E4.8 Photoluminescent exit signs**Deemed-to-Satisfy Provisions**

- 1 Scope
- 2 Application
- 3 Illumination
- 4 Pictorial elements
- 5 Viewing distance
- 6 Smoke control systems

Part E1 Fire fighting equipment

Objective

EO1

The Objective of this Part is to—

- (a) safeguard occupants from illness or injury while evacuating during a fire; and
- (b) provide facilities for occupants and the fire brigade to undertake fire-fighting operations; and
- (c) prevent the spread of fire between buildings.

Fire in buildings

If a fire occurs in a building it must not endanger evacuating occupants or spread to another building.

Facilities to fight a fire in its early stages

Simple and lightweight equipment allows occupants to attack a fire during its early stages. Provision of this equipment often helps occupants to either extinguish or limit the development of a fire before the fire brigade arrives.

Facilities to assist the fire brigade

To assist in stopping or limiting the spread of fire, facilities must be provided to assist the fire brigade.

Functional Statements

EF1.1

A building is to be provided with fire-fighting equipment to safeguard against fire spread—

- (a) to allow occupants time to evacuate safely without being overcome by the effects of fire; and
- (b) so that occupants may undertake initial attack on a fire; and
- (c) so that the fire brigade have the necessary equipment to undertake search, rescue, and fire-fighting operations; and
- (d) to other parts of the building; and
- (e) between buildings.

Suitable facilities to be installed

Suitable facilities may need to be installed in a building to minimise the risk of fire spread to:

- enable occupants to evacuate;
- enable occupants and the fire brigade to fight the fire and for the fire brigade to undertake rescue operations; and
- minimise the damage which could result from fire spreading to other parts of the building or other buildings.

Facilities may be manually or automatically operated, and include: fire hydrants; fire hose reels; sprinkler systems; portable fire extinguishers.

Buildings may incorporate a fire-control centre.

Performance Requirements

EP1.1 Fire hose reels

Fire hose reels in buildings allow occupants to fight a fire. The fire may be in its infancy, and early control or extinguishment may reduce the hazard, allow more time for evacuation and prevent structural damage.

“To the degree necessary”

See the explanation of this term in [A1.0\(3\)\(c\)](#).

Criteria for fire hose reels

As set out in [EP1.1](#), fire hose reels must be installed when necessary, and be appropriate to a number of factors, including:

Services and equipment

- the size of the fire compartment which is a measure of the size of any potential fire;
- the function of the building will affect the fire load in the building;
- the fire-safety systems which can affect the rate of fire spread (eg if a sprinkler system is installed in a building, it should extinguish the fire or reduce its growth rate); and
- the fire hazard which means the danger in terms of potential harm and degree of exposure arising from the start and spread of fire, and the smoke and gases generated by a fire.

Deemed-to-Satisfy Provisions

[E1.4](#) provides a number of examples where fire hose reels must be installed if the proposal being considered involves a solution which uses the Deemed-to-Satisfy Provisions.

Performance Solutions

If a Performance Solution is used, it may be appropriate to assess it using [E1.4](#) for guidance purposes. However, it is stressed that compliance with [E1.4](#) is not compulsory if alternative means can be found to satisfy the appropriate authority that the Performance Requirements will be achieved.

EP1.2 Fire extinguishers

Fire extinguishers in buildings allow occupants to fight fires. Extinguishment may complete all the functions listed in [EP1.1](#) above.

Fire extinguishers should be located in plain view, along normal paths of travel and near exits where possible. They should not be located in hazardous places.

“To the degree necessary”

This expression’s use in [EP1.2](#) indicates that the BCA recognises that not all buildings need fire extinguishers; and fire extinguishers are used for specific purposes, as set out in AS 2444.

Any decision made in this context can extend to not requiring an item to be installed or a particular level of performance to be achieved, if that is the appropriate action to be taken.

Criteria for fire extinguishers

As set out in [EP1.2](#), fire extinguishers must be installed when necessary, and be appropriate to a number of factors, including:

- the function or use of the building will affect the fire load in the building;
- the fire-safety systems in the building which can affect the rate of fire spread (eg if a sprinkler system is installed in a building, it should extinguish the fire or reduce its growth rate); and
- the fire hazard which means the danger in terms of potential harm and degree of exposure arising from the start and spread of fire, and the smoke and gases generated by a fire.

Deemed-to-Satisfy Provisions

[Table E1.6](#) provides a number of examples where fire extinguishers must be installed if the proposal being considered involves a solution which uses the Deemed-to-Satisfy Provisions.

Performance Solutions

If a Performance Solution is being used, it may be appropriate to assess it using [Table E1.6](#) for guidance purposes. However, it is stressed that compliance with [Table E1.6](#) is not compulsory if alternative means can be found to satisfy the appropriate authority that the Performance Requirements will be achieved.

EP1.3 Fire hydrants

The intent of installing a fire hydrant system is to provide adequate water, under sufficient pressure and flow, to allow the fire brigade to fight fires.

Under its Application provision, [EP1.3](#) only applies to buildings located in an area serviced by a fire brigade. This is primarily because the pressures and flows from a fire hydrant are such that hydrants should only be used by the fire brigade.

It is expected that designers will meet any special fire brigade requirements, which may cover such matters as the types of couplings and special flows and pressures to suit a particular nozzle.

“To the degree necessary”

The use of the expression “to the degree necessary” in [EP1.3](#) indicates that the BCA recognises that not all buildings need fire hydrants.

Any decision made in this context can extend to not requiring an item to be installed or a particular level of performance to be achieved, if that is the appropriate action to be taken.

Services and equipment

Criteria for fire hydrant systems

As set out in [EP1.3](#), a fire hydrant system must be installed when necessary, and be appropriate to a number of factors, including:

- the need to meet the requirements of the local fire brigade (because of the pressures and flows), fire hydrants should only be used by the fire brigade;
- the floor area of the building which is a measure of the size of any potential fire; and
- the fire hazard which means the danger in terms of potential harm and degree of exposure arising from the start and spread of fire, and the smoke and gases generated by a fire.

Deemed-to-Satisfy Provisions

[E1.3](#) provides a number of examples where fire hydrants must be installed if the proposal being considered involves a solution which uses the Deemed-to-Satisfy Provisions.

Performance Solutions

If a Performance Solution is used, it may be appropriate to assess it using [E1.3](#) for guidance purposes. However it is stressed that compliance with [E1.3](#) is not compulsory if alternative means can be found to satisfy the appropriate authority that the Performance Requirements will be achieved.

EP1.4 Automatic fire suppression systems

EP1.4 is not limited to sprinkler systems

A sprinkler system is only one type of automatic fire suppression system. [EP1.4](#) is not limited to sprinkler systems. If it can be demonstrated that another automatic fire system can control the development and spread of a fire, it may comply with [EP1.4](#). Its activation must be “automatic” and must not depend on human intervention.

Life safety and fire suppression

Automatic fire suppression systems, such as sprinkler systems, are normally used in a building to contain and extinguish fire. When an automatic fire suppression system operates, it not only controls or limits the fire development, but statistics show that, in most cases, the fire is extinguished before the fire brigade arrives at the building.

An automatic fire suppression system is regarded as part of a building’s life safety package because:

- if the system extinguishes the fire before it fully develops, the fire will not endanger the occupants; and
- if the system limits or controls the spread of a fire, it allows occupants more time to evacuate to a safe place.

“To the degree necessary”

The use of the expression “to the degree necessary” in [EP1.4](#) indicates that the BCA recognises that not all buildings need an automatic fire suppression system.

Any decision made in this context can extend to not requiring an item to be installed or particular level of performance to be achieved, if that is the appropriate action to be taken.

Criteria for automatic fire suppression systems

As set out in [EP1.4](#), an automatic fire suppression system, such as a sprinkler system, must be installed when necessary, and be appropriate to a number of factors.

When implementing, the likely size and intensity of a fire should be taken into consideration. This can be as measured by:

- the size of the fire compartment which is a measure of the size of any potential fire;
- the function or use of the building will affect the fire load in the building;
- the fire hazard which means the danger in terms of potential harm and degree of exposure arising from the start and spread of fire, and the smoke and gases generated by a fire; and
- the height of the building, because once a building gets above a certain height it becomes extremely difficult (and eventually impossible) for the fire brigade to undertake external rescue or firefighting from ladders and the like. The height also affects evacuation time.

Deemed-to-Satisfy Provisions

[E1.5](#) provides a number of examples where a sprinkler system must be installed if the proposal being considered involves a solution which uses the Deemed-to-Satisfy Provisions.

Performance Solutions

If a Performance Solution to the Deemed-to-Satisfy Provisions in [Part E1](#) is being used, it may be appropriate to assess it using [E1.5](#) for guidance purposes. However, it is stressed that compliance with [E1.5](#) is not compulsory if alternative means can be found to satisfy the appropriate authority that the Performance Requirements will be achieved.

Services and equipment

EP1.5 Firefighting services in buildings under construction

A fire in a building under construction represents a significant public safety, health and amenity risk. Accordingly, there is a need for firefighting in such buildings.

This Performance Requirement recognises the fact that a significant number of fires occur in buildings during their construction or major refurbishment. Statistics indicate that a number of fires have been started by sparks. The fire has then spread because services were turned off for construction purposes.

“To the degree necessary”

The use of the expression “to the degree necessary” in [EP1.5](#) indicates that the BCA recognises that not all buildings need firefighting services during construction.

Any decision made in this context can extend to not requiring an item to be installed or a particular level of performance to be achieved, if that is the appropriate action to be taken.

Criteria for firefighting services in buildings under construction

As set out in [EP1.5](#), firefighting services must be installed in buildings under construction when necessary, and must be appropriate to a number of factors, including:

- the fire hazard which means the danger in terms of potential harm and degree of exposure arising from the start and spread of fire, and the smoke and gases generated by a fire; and
- the height the building has reached during its construction which is a measure of the extent to which the fire brigade can fight any fire from the outside of the building.

Deemed-to-Satisfy Provisions

[E1.9](#) provides a number of examples where firefighting services must be installed if the proposal being considered involves a solution which uses the Deemed-to-Satisfy Provisions.

Performance Solutions

If a Performance Solution to the Deemed-to-Satisfy Provisions in [Part E1](#) is being used, it may be appropriate to assess it using [E1.9](#) for guidance purposes. However, it is stressed that compliance with [E1.9](#) is not compulsory if alternative means can be found to satisfy the appropriate authority that the Performance Requirements will be achieved.

EP1.6 Fire control centres

[EP1.6](#) requires that a part of a building be set aside for the fire brigade to co-ordinate its search and rescue, and firefighting operations during a fire. These areas are referred to as “fire control centres”.

“To the degree necessary”

The use of the expression “to the degree necessary” in [EP1.6](#) indicates that the BCA recognises that not all buildings need a fire control centre.

Any decision made in this context can extend to not requiring an item to be installed or a particular level of performance to be achieved, if that is the appropriate action to be taken.

Criteria for co-ordination facilities

As set out in [EP1.6](#), co-ordination facilities must be installed when necessary, and be appropriate to a number of factors, including:

- the function or use of the building will affect the fire load in the building;
- the floor area of the building which is a measure of the size of any potential fire; and
- the height of the building which is a measure of the extent to which the fire brigade can fight any fire or carry out rescue operations from the outside of the building and the evacuation time.

Deemed-to-Satisfy Provisions

[E1.8](#) provides a number of examples where a fire control centre must be installed if the proposal being considered involves a solution which uses the Deemed-to-Satisfy Provisions.

Performance Solutions

If a Performance Solution to the Deemed-to-Satisfy Provisions in [Part E1](#) is being used, it may be appropriate to assess it using [E1.8](#) for guidance purposes. However, it is stressed that compliance with [E1.8](#) is not compulsory if alternative means can be found to satisfy the appropriate authority that the Performance Requirements will be achieved.

Part E1 Fire fighting equipment

Deemed-to-Satisfy Provisions

E1.0 Deemed-to-Satisfy Provisions

Intent

To clarify that the requirements of [EP1.1](#) to [EP1.6](#) will be satisfied if compliance is achieved with [E1.1](#) to [E1.10](#) in the case of all buildings, [Part G3](#) in the case of buildings with an atrium, [Part G4](#) in the case of buildings in alpine areas, [Part G6](#) in the case of occupiable outdoor areas, [Part H1](#) in the case of theatres, stages and public halls and [Part H3](#) for farm buildings and farm sheds.

E1.1 * * * * *

In BCA 1990 this clause contained provisions relating to Class 1 and Class 10. Provisions for Class 1 and Class 10 buildings are now covered in Volume Two. [E1.1](#) has been left blank rather than renumber subsequent clauses.

E1.2 * * * * *

In BCA 1990 this clause contained requirements for fire mains and water-supply services. These provisions are now covered by the referenced Standard AS 2419.1. [E1.2](#) has been left blank rather than renumber subsequent clauses.

E1.3 Fire hydrants

Intent

To require the installation of suitable fire hydrant systems to facilitate the fire brigade's firefighting operations.

When required—[E1.3\(a\)](#)

Fire hydrants are needed to prevent the spread of fire between buildings and fire compartments. They are basically needed for fire brigade use and are not intended for use by occupants. Properly trained people and special equipment are needed for effective firefighting using a fire hydrant system.

The floor area of 500 m² referred to in [E1.3\(a\)\(i\)](#) represents the level of hazard which justifies the installation of a fire hydrant system.

If the building is located a substantial distance from a fire brigade station equipped to utilise fire hydrants, [E1.3\(a\)\(ii\)](#) allows the building to be constructed without a fire hydrant system. The reasons for this are that the fire hydrants are intended for use only by a fire brigade and the benefit of fire brigade intervention during a building fire is expected to diminish with the passage of time.

AS 2419.1—[E1.3\(b\)\(i\)](#)

Under [E1.3\(b\)\(i\)](#), the installation of a fire hydrant system, including the associated water supply, pipe work, pumps, and so on, must be in accordance with AS 2419.1 subject to concessions granted under and [E1.3\(b\)\(i\)\(C\)](#).

Clause 4.2 of AS 2419.1 requires a four hour water storage capacity for firefighting purposes. This clause does not apply to Class 8 electricity network substations where town main water supply cannot be connected and where at least 1 hour storage capacity of water for fire fighting purposes is provided. The reduced capacity is in recognition of the inherent fire mitigation measures such as boundary separation, vegetation removal programs, and perimeter access road protection associated with remotely located Class 8 electricity network substations. The nature of the initial fire response will also always require substation staff involvement prior to any fire brigade response. This removes the need for large water storage capacities usually associated with early intervention by the fire brigade.

If any conflict exists between AS 2419.1 and the BCA, then the BCA takes precedence. Additional information can be obtained by reference to the Standard, including an informative Appendix titled "Guide to the Use of this Standard".

AS 2419.1 provides the details for determining the number of fire hydrants required and where they should be located.

Location—[E1.3\(b\)](#)

External fire hydrants are to be located in accordance with the requirements of AS 2419.1. Multiple buildings may be served by a single fire hydrant providing the proximity requirements of AS 2419.1 are met.

[E1.3\(b\)\(i\)\(C\)](#) provides a concession from the booster assembly protection requirements of clauses 7.3(c)(ii) and 7.3(d)(iii)

Services and equipment

of AS 2419.1 where a sprinkler system is installed throughout the building in accordance with AS 2118.1, AS 2118.4, AS 2118.6, FPAA101D or FPAA101H.

[E1.3\(b\)\(i\)\(C\)](#) allows a smaller booster assembly protection wall than that required by clause 7.3(d)(iii) of AS 2419.1 where requirements set out in the provision are met.

For internal fire hydrants, [E1.3\(b\)\(ii\)](#) generally requires the installation of internal fire hydrants on the storey they are to service. The reason for this is to eliminate running a fire hydrant hose up or down a stairway. Also, if the sole-occupancy units are in different ownership or leasehold, access between them may be difficult.

[E1.3\(b\)\(ii\)](#) grants a concession when a sole-occupancy unit occupies more than one storey. The concession is conditional on the fire hydrant being located at the level of egress from the sole-occupancy unit.

In the case of a Class 2 or Class 3 building or a Class 4 part, there is no limitation on the size or number of storeys within the sole-occupancy unit which can be served by the fire hydrant.

For Class 5 to Class 9 buildings the concession is limited to sole-occupancy units with only two storeys, where the fire hydrant at the entrance level provides total hose coverage. AS 2419.1 provides details of the required coverage.

Pumpsets

Requirements for pumpsets, including the location of pumprooms, etc., is contained in AS 2419.1.

Water source, pressures and flows

The requirements for the water supply and source, and the required flows and pressure for the fire hydrant system to operate effectively are contained in AS 2419.1.

E1.4 Fire hose reels

Intent

To require the installation of suitable fire hose reel systems to enable, where appropriate, a building's occupants to undertake initial attack on a fire.

When required—[E1.4\(a\)](#)

Refer to [EP1.1](#) for the reasons why the BCA requires the installation of fire hose reels in buildings.

[E1.4\(a\)\(i\)](#) provides an exemption to the installation of fire hose reels in a Class 2, 3 or 5 building or Class 4 part of a building. However, it should be noted that portable fire extinguishers must be installed to cover Class A fire risks in accordance with [E1.6](#).

[E1.4\(a\)\(ii\)](#) provides an exemption to the installation of fire hose reels in Class 8 electricity network substations. The use of water as an extinguishing medium in electricity network substations can cause extensive damage to the electricity assets and create increased hazards for firefighters. The initial staff response to fire will always be through the more appropriate usage of portable fire extinguishers followed by evacuation.

[E1.4\(a\)\(iii\)](#) does not require the installation of fire hose reels in a Class 9c building. It is recognised that occupants close to the point of ignition often provide the most effective means of extinguishing a small fire before it grows. In this case staff and visitors, if not some residents, can be effective in performing this function. To do so, they require appropriate means of extinguishment.

It is considered that the provision of portable extinguishers in a residential care building provides adequate means for staff and visitors to attack the fire. The additional level of fire safety associated with the provision of fire hose reels is not considered necessary.

It is not expected that the number of staff available in a residential care building will be adequate to both fight a growing fire with fire hose reels and evacuate residents. This is particularly the case when it is noted that the BCA provisions for residential care buildings are based on minimum staffing levels. When a fire becomes too large to be attacked with portable extinguishers, staff will be fully involved in closing doors and evacuating residents rather than fighting the fire.

[E1.4\(a\)\(iv\)](#) does not require the installation of fire hose reels in classrooms and associated corridors of primary and secondary schools. However, it should be noted that where fire hose reels are not installed in these buildings, portable fire extinguishers must be installed in accordance with [E1.6](#).

The concession not requiring the installation of fire hose reels in classrooms, etc is based on normal school use when teachers or school staff could be expected to be in control of students for the purpose of evacuation. Fire hose reels are required in other areas of the school such as halls, gymnasiums, etc where activities take place outside normal school hours and with outside organisations that are not under the control of teachers or school staff.

[E1.4\(b\)\(i\)](#) requires the installation of fire hose reels where internal fire hydrants are provided.

The 500 m² floor area referred to in [E1.4\(b\)\(ii\)](#) represents the level of hazard which justifies the installation of fire hose reels to allow occupants the opportunity to attempt an initial attack on a fire.

Services and equipment

System design—E1.4(c)

[E1.4\(c\)\(ii\)](#) generally requires the installation of fire hose reels on the storey they are to service. This eliminates the need to run a fire hose up or down a stairway. Also, if the sole-occupancy units are in different ownership or leasehold, access between them may be difficult. It means that anyone using the fire hose will be able to get away quickly if the fire gets out of control.

[E1.4\(c\)\(ii\)](#) grants a concession when a sole-occupancy unit in a Class 6–9 building occupies two storeys provided the fire hose reel can provide total hose coverage. The fire hose reel must also be located at the level of egress from the sole-occupancy unit.

[E1.4\(d\)](#), [\(e\)](#) and [\(f\)](#) relates to the positioning of fire hose reels to help occupants attack a fire in its early stages. These provisions emphasise the importance of the location of fire hose reels to ensure safety.

[E1.4\(d\)](#) ensures that fire hose reels are located to achieve the system coverage required by AS 2441. The fire hose reels can be located internally, externally or in any combination to achieve this coverage as set out in [E1.4\(e\)](#).

Fire hose reels are not permitted to be installed within a fire-isolated exit, thereby avoiding having the hose pass through the door to access the fire. Such an arrangement would require the exit to be open, and therefore cause a significant risk of smoke entering.

The same concerns do not apply to the other Deemed-to-Satisfy Provisions listed in [E1.4\(f\)](#). In the cases listed below, the door may remain open for the hose to pass through.

- [C2.5\(a\)\(v\)](#) deals with walls in Class 9a buildings which are required to separate ancillary areas located within a patient care area and containing equipment or materials that are a high potential fire hazard.
- Likewise, [C2.5\(b\)\(iv\)](#) deals with similar walls in Class 9c buildings.
- [C2.12](#) deals with the fire isolation of specified hazards and equipment such as lift motors, lift control panels, emergency generators, central smoke control plant, boilers and batteries.
- [C2.13](#) deals with doors to electricity substations, and the like.
- [C3.13](#) deals with openings in shafts. [C2.12](#) deals with the fire isolation of specified hazards and equipment.

[E1.4\(e\)](#) is applicable to individual fire hose reels, such that the choices offered in [E1.4\(e\)\(i\)](#), [\(ii\)](#) or [\(iii\)](#) are applied to the location of each hose reel in turn, to assure that coverage is achieved. However [E1.4\(e\)\(iii\)](#) is only applicable when the application of [E1.4\(e\)\(i\)](#) or [\(ii\)](#) does not achieve coverage.

The individual application means that when each hose reel is located adjacent to a hydrant or an exit, a check for coverage should be done before the next location is chosen.

Once coverage has been achieved, it is not necessary to install any more hose reels, even if additional exits or hydrants are provided for the storey.

Alternatively, if hose reels have been located adjacent to all relevant hydrants or exits without achieving coverage, [E1.4\(e\)\(iii\)](#) permits the additional hose reels needed to achieve coverage to be located in a path of travel to an exit.

E1.5 Sprinklers

Intent

To require the installation of suitable fire sprinkler systems where necessary to address specific hazards.

When required

Refer to the comment on [EP1.4](#) for the reasons why the BCA requires the installation of sprinkler systems in buildings.

[Table E1.5](#) sets out when sprinklers are required in a building, while [Specification E1.5](#) sets out the type of sprinkler required and other technical details. The notes to [Table E1.5](#) also contain useful information on other Parts of the NCC requiring the installation of sprinklers within a building.

[Specification E1.5](#) allows the use of a residential sprinkler system in certain Class 2, 3, 9a and 9c buildings.

Table E1.5

[Table E1.5](#) specifies when sprinklers are required in a building and which parts of the building must be sprinkler protected. Unless a fire wall or other construction with the appropriate FRLs separates parts of a building required to have sprinklers from a part of a building not required to have sprinklers, then the sprinkler requirements must be applied to the whole building.

[Table E1.5](#) requires all buildings with an effective height of more than 25 metres, except those which only contain an open-deck carpark, to be sprinkler protected. An exemption is also granted to smaller Class 8 electricity network substations within a multi-classified building as they are provided with additional fire protection measures to compensate for the removal of sprinklers. The provision regarding an effective height of 25 metres recognises the effective operating height for fire

Services and equipment

brigade ladders and other firefighting and rescue equipment.

[Table E1.5](#) requires sprinkler protection to Class 2 or 3 buildings (excluding a residential care building — see other table items for residential care buildings) where the rise in storeys is 4 or more and the effective height is not more than 25 m. The requirements for these sprinkler systems are contained within [Specification E1.5](#) and [Specification E1.5a](#).

The reference in [Table E1.5](#) to a Class 9a health care building used as a residential care building makes it clear that where a Class 9a building is used as a residential care building as defined in [Schedule 3](#), it must be fitted with a sprinkler system installed in accordance with AS 2118.1 or AS 2118.4.

To provide further clarification, a Class 9a health care building used as a residential care building must meet the BCA provisions that apply for a Class 9a health care building.

The definition of a health care building means a building whose occupants or patients undergoing medical treatment need physical assistance to evacuate the building during an emergency and includes a nursing home or similar facility for sick or disabled persons needing full-time care. Therefore, a health care building could include a residential aged care building in which occupants are provided with some level of medication, and need assistance to evacuate.

Notes 1, 2 and 3 to [Table E1.5](#) contain useful references to other BCA provisions that may require the installation of a sprinkler system.

E1.6 Portable fire extinguishers

Intent

To require the installation of suitable portable fire extinguishers, where necessary, to address specific hazards.

When required

Refer to the comment on [EP1.2](#) for the reasons why the NCC requires the installation of portable fire extinguishers in buildings.

[E1.6\(a\)\(i\)](#) requires portable fire extinguishers to be provided as listed in [Table E1.6](#).

For a Class 2, 3 or 5 building or Class 4 part of a building, [E1.6\(a\)\(ii\)](#) requires portable fire extinguishers to only be provided—

- [E1.6\(a\)\(ii\)\(A\)](#)—to serve the whole Class 2, 3 or 5 building or Class 4 part of a building where internal fire hydrants are installed; or
- [E1.6\(a\)\(ii\)\(B\)](#)—where internal fire hydrants are not installed, to serve any fire compartment with a floor area greater 500 m². For the purpose of this clause, a sole-occupancy unit in a Class 2 or 3 building or Class 4 part of a building is considered a fire compartment. The 500 m² floor area represents the level of hazard which justifies the installation of portable fire extinguishers to allow occupants the opportunity to attempt an initial attack on a fire.

Subject to [E1.6\(b\)](#), [E1.6\(a\)\(iii\)](#) requires portable fire extinguishers to be installed in accordance with Sections 1, 2, 3 and 4 of AS 2444. The other sections of AS 2444 deal with “Selection and distribution of portable fire extinguishers in vehicles and small craft” and “Selection and location of fire blankets”, neither of which are applicable to the BCA. If any conflict exists between AS 2444 and the BCA, then the BCA takes precedence. Additional information can be obtained by reference to the Standard.

[E1.6\(b\)](#) details specific requirements about the type, size and installation of portable fire extinguishers provided in a Class 2 or 3 building or Class 4 part of a building.

[Table E1.6](#) sets out when portable fire extinguishers are required in a building and the class of extinguisher to be used.

It should be noted that [Table E1.6](#) requires the installation of fire extinguishers in classrooms and associated corridors in primary and secondary schools not provided with fire hose reels. The reason for this requirement is that [E1.4\(a\)\(iv\)](#) does not require the installation of fire hose reels in these buildings, even if the floor area of a fire compartment exceeds 500 m².

E1.7 * * * * *

This clause originally contained provisions relating to fire alarms. These provisions are now covered in [Part E2](#). [E1.7](#) has been left blank rather than renumber subsequent clauses.

E1.8 Fire control centres

Intent

To require the provision of suitable fire control centres to facilitate fire brigade operations.

Services and equipment

When required

Refer to the comment on [EP1.6](#) for the reasons why the BCA requires the installation of fire control centres in buildings.

[E1.8\(a\)](#) requires all buildings with an effective height of more than 25 metres to be provided with a fire control centre. Because of their height these buildings require special co-ordination of fire brigade operations. The [E1.8\(a\)](#) reference to an effective height of 25 metres recognises the operating height for fire brigade ladders and other firefighting and rescue equipment.

[E1.8\(b\)](#) requires a fire control centre for Class 6–9 buildings with a total floor area of more than 18 000 m².

The measurement concerned is of the total building floor area, not the area of an individual sole-occupancy unit or fire compartment.

Class 6 and Class 9 buildings have been included because of their high potential fire load, and the likelihood of large populations unfamiliar with their layout or evacuation procedures.

Class 7 and Class 8 buildings have been included because of the potential size and severity of fires in such buildings.

[Specification E1.8](#) sets out the construction details of such a centre and the facilities it must contain.

E1.9 Fire precautions during construction

Intent

To require adequate firefighting equipment within a building during its construction.

When required

Refer to the comment on [EP1.5](#) for the reasons why the BCA requires the installation of firefighting equipment in buildings during their construction.

[E1.9\(a\)](#) requires the installation of suitable fire extinguishers in all buildings under construction. They are to be placed adjacent to exits on each storey so that they can be easily found by workers if a fire occurs.

Once a building reaches a height of about 12 metres, firefighting in a building under construction becomes increasingly difficult. The installation of fire hydrants, fire hose reels and booster connections (required under [E1.9\(b\)](#)) assist in overcoming such difficulties.

The fire hydrants and fire hose reels are not required on the two upper floors because services such as water supply may not be installed. Also, if a fire occurred on these floors, it could be fought from the floors below.

E1.10 Provision for special hazards

Intent

To require the installation of additional fire safety measures where special hazards exist.

When required

The other Deemed-to-Satisfy Provisions of [Part E1](#) set out the required firefighting equipment and co-ordination facilities required in a building to deal with “expected” or “usual” hazards. However, it is not possible to take account of every possible hazard. [E1.10](#) may even require additional provision for special hazards where [Part E1](#) does not otherwise apply.

Additional provision for special hazards must be made to allow for effective firefighting operations taking into consideration:

- the nature of the materials stored, displayed or used in the building or on the allotment; or
- inadequate water supply for firefighting.

Examples

Special fire hazards may exist for hazards under [E1.10\(a\)](#) in a warehouse used to store highly volatile or combustible materials, and also, at a site where highly combustible chemicals are manufactured.

Hazards under [E1.10\(b\)](#) may include sites where little or no water is available for firefighting.

The BCA Deemed-to-Satisfy Provisions do not specify what the special provisions must be. Each case must be assessed on its own merits.

Specification E1.5 Fire sprinkler systems

Deemed-to-Satisfy Provisions

1 Scope

Intent

To state that [Specification E1.5](#) gives the design and installation details for sprinkler systems required by the Deemed-to-Satisfy Provisions.

Design and installation—sprinkler systems

[Clause 1](#) deals with the intent.

Examples

A number of the Deemed-to-Satisfy Provisions require the installation of sprinklers in accordance with [Specification E1.5](#). These include:

- [E1.5](#)—Sprinklers;
- [Part E2](#)—Smoke Hazard Management;
- [C2.3\(b\)](#)—Large isolated buildings;
- [Specification G3.8](#)—Fire and smoke control in buildings containing atriums;
- [Clauses 3.9, 4.2 and 5.2](#) of [Specification C1.1](#) when granting a concession for enclosed car parks;
- [Clause 2.9](#) of [Specification C1.1](#) for residential care buildings; and
- [Clauses 3.10 and 4.3](#) of [Specification C1.1](#) for multi-storey, timber framed, Class 2 buildings.

2 Application of automatic fire sprinkler standards

Intent

To adopt the appropriate technical standards for the design and installation of sprinkler systems.

Adoption of three Parts of AS 2118

[Specification E1.5](#) adopts three Parts of AS 2118:

- AS 2118.1—*Automatic fire sprinkler systems Part 1: General systems*; and
- AS 2118.4—*Automatic fire sprinkler systems Part 4: Residential*; and
- AS 2118.6—*Automatic fire sprinkler systems Part 6: Combined sprinkler and hydrant*.

AS 2118.1 applies to all classes of buildings—[Clause 2\(a\)](#)

Part 1 of AS 2118 applies to all Classes of building.

AS 2118.4—[Clause 2\(b\)](#) and [\(d\)](#)

These clauses allow the use of Part 4 of AS 2118 for Class 2, 3, 9a and 9c buildings as appropriate. The reason for using the term “as applicable” is that AS 2118.4 applies to low-rise Class 2, 3, 9a and 9c buildings. The scope of AS 2118.4 states that it only applies to those buildings containing no more than four storeys. If the building exceeds this height, it must comply with AS 2118.1. While the scope of AS 2118.4 may not mention Class 9a buildings, this is a case where [A4.1](#) applies and the BCA requirement overrules the limited scope in AS 2118.4.

The sprinkler system specified under AS 2118.4 has been designed for use in low-rise residential buildings. AS 2118.4 also takes into consideration the economic aspects of a sprinkler system.

AS 2118.4 provides the requirements for sprinklers in residential buildings.

A sprinkler system installed in accordance with AS 2118.4 is designed to prevent the fire reaching the stage at which “flashover” occurs (i.e. total involvement of a room’s contents in a fire), thus reducing the risks to occupants.

Smoke detection matters are dealt with in [Part E2](#).

Combined sprinkler and hydrant systems—[Clause 2\(c\)](#)

[Clause 2\(c\)](#) allows the installation of a combined sprinkler and hydrant system provided it complies with AS 2118.6.

Services and equipment

Adoption of the Fire Protection Association Australia (FPAA) Technical Specifications

[Specification E1.5](#) adopts two Technical Specifications developed by FPAA:

- FPAA101D—*Automatic fire sprinkler system design and installation — Domestic water supply*; and
- FPAA101H—*Automatic fire sprinkler system design and installation — Hydrant water supply*.

[Clause 2\(b\)](#) references [Specification E1.5a](#) providing an option to use automatic fire sprinkler systems complying with FPAA101D or FPAA101H in Class 2 or 3 buildings (excluding residential care buildings) with a rise in storeys of 4 or more and an effective height up to and including 25 metres.

3 Separation of sprinklered and non-sprinklered areas

Intent

To require the fire separation of sprinklered parts of a building from non-sprinklered parts of the building.

Size and intensity of an assumed fire

The design of a sprinkler system is based on the size and intensity of an assumed fire in the building. The BCA assumes that fire size is controlled by the sprinkler system.

A fire in a non-sprinklered part of a building

If a fire starts in a non-sprinklered part of the building, its development will be uncontrolled. It can even reach a size which could over-ride the sprinkler system if it spreads to the sprinklered part of the building (i.e. it could be beyond the design capacity of the system).

Separation between sprinklered and non-sprinklered parts

[Clause 3\(a\)](#) applies wherever there is a specific Deemed-to-Satisfy Provision.

The fire separation required by AS 2118.1, FPAA101D and FPAA101H may differ from that required by the BCA. [Clause 3\(b\)](#) clarifies that if a difference exists between AS 2118.1, FPAA101D and FPAA101H and the BCA, the BCA takes precedence.

AS 2118.1 generally requires a 120/120/120 FRL separation between the sprinklered and non-sprinklered parts of a building to minimise the risk of fire spread from non-sprinklered parts (where a fire's development is substantially uncontrolled) to a sprinklered part (where the sprinkler system is designed on the basis of a likely fire in that part of the building).

4 Protection of openings

Intent

To require the fire separation of sprinklered parts of a building from non-sprinklered parts of the building.

The aim of [Clause 4](#) is similar to [Clause 3](#), but it particularly deals with the protection of openings, in the construction, between sprinklered and non-sprinklered parts of a building.

5 Fast response sprinklers

Intent

To allow the use of fast response sprinkler heads.

Where “fast response” sprinkler heads register a specific external temperature, their reaction time is much shorter than for a “normal” sprinkler head. They also have different discharge characteristics. Where “fast response” sprinkler heads are used, the sprinkler system must be designed specifically for their use.

6 Sprinkler valve enclosures

Intent

To require the location of sprinkler valves in a secure, easily accessible area.

Sprinkler control valves—location

Sprinkler control valves must be located in a secure area to prevent unauthorised tampering or vandalism.

“Direct egress to a road or open space”

Services and equipment

[Clause 6\(a\)](#) requires that sprinkler alarm valves be in a room having “direct egress to a road or open space”. The intent is to help fire brigade personnel gain quick access to valves, and, if the need arises, to exit quickly.

When interpreting the expression “direct egress to a road or open space”, it should be noted that [D1.10\(c\)](#) requires that if an exit discharges to open space which is at a different level from the public road to which it is connected, the path of travel to the road must be by a ramp or stairway complying with the BCA.

The aim is to provide quick egress, if the need arises. For this purpose it would be reasonable to limit the stairway to one flight. The landing and stairway must not expose a user to fire or smoke generated by a fire in the building. Care must therefore be taken to make sure windows and other openings are correctly located, and that the external walls of the building have an appropriate FRL.

7 Water supply

Intent

To require an adequate water supply when a sprinkler system has been installed.

A dual water supply is required for buildings greater than 25 metres in effective height, however a concession for the secondary water supply is permitted in certain circumstances (see [Clause 7\(b\)](#)).

At least one water supply is required for buildings with an effective height of 25 m or less (see [Clause 7\(a\)](#)).

8 Building occupant warning system

Intent

To maximise the effectiveness of a sprinkler system by alerting the occupants throughout the building of a potential emergency.

AS 1670.1

[Clause 8](#) requires a sprinkler system (except for FPAA101D systems) to be connected to activate a warning system complying with [Specification E2.2a](#), [Clause 7](#). This is an AS 1670.1 warning system which is to operate throughout the occupied parts of the building.

Different types of warning devices permitted

AS 1670.1 allows the warning system to be:

- a warning system complying with AS 2220;
- electronic sounders generating evacuation tones in accordance with AS 2220; or
- another warning device approved by the appropriate authority.

See AS 2220.

9 Connection to other systems

Intent

To allow the interconnection of a sprinkler system with other fire safety systems.

Activation of smoke hazard management system

Modern fire safety designs allow for the interaction of the various safety systems during a fire. [Clause 9](#) requires that where a smoke hazard management system is activated by a smoke detector, “wherever practicable” it must also be activated by the sprinkler system.

Note this provision only applies “wherever practicable”. In other words, if a building proposal includes a smoke hazard management system which is activated by smoke detectors, but it is proposed that the smoke hazard management system will not be activated by the sprinkler system, the building proponent must satisfy the appropriate authority that it is not practicable to do so.

10 Anti-tamper devices

Intent

To provide for the continued operational effectiveness of sprinkler heads in certain areas.

Stages used for live performances—high fire load

Services and equipment

Stages used for live performances can contain high fire loads due to the scenery and other props used in these productions, and particularly hazardous stage activities, such as pyrotechnics.

[Clauses 10\(a\)](#) and [\(c\)](#) require that sprinkler valves located in an area normally used by the stage manager (for theatres, halls or over a stage area), to be fitted with anti-tamper devices connected to a monitoring panel.

11 Sprinkler systems in carparks

Intent

To provide for sprinkler systems in certain carparks to operate independently or be isolated from the system in other parts of the building.

Carparks

[Table 3.9](#) of [Specification C1.1](#) grants concessions for the FRL of structural members within carparks in buildings required to be of Type A construction. Therefore, [Clause 11](#) of [Specification E1.5](#) only applies to such buildings.

[Clause 11](#) does not apply to [Tables 4.2](#) and [Table 5.2](#) of [Specification C1.1](#) for carparks in buildings required to be of Type B or Type C construction.

If a building required to be of Type A construction contains an enclosed carpark, in order to take advantage of the concession allowed by [Table 3.9](#), it must contain a sprinkler system which is independent or can be separately isolated.

The reason for this requirement is so that the carpark's protection is available at all times, and is not affected by such factors as maintenance or shutdown in other parts of the building.

12 Residential care buildings

Intent

To ensure greater reliability of sprinkler systems in all buildings used for residential care.

[Clause 2](#) of [Specification E1.5](#) allows a sprinkler system in a Class 2 or 3 building, a Class 9a health care building used for residential care, or a Class 9c building to comply with AS 2118.4 instead of AS 2118.1. [Clause 12\(d\)](#) requires the addition of a monitored main valve and control valve assembly in accordance with AS 2118.1. The reason for the additional requirement is to ensure greater reliability of the sprinkler system.

[Clause 12\(e\)](#) specifies system monitoring requirements to enable a timely and appropriate response by the local fire brigade to emergencies.

[Clause 2.10.1.3](#) of AS 2118.4 sets out the requirements for the installation of sprinklers in roof spaces, etc. Spaces such as roof spaces, crawl spaces, spaces below floor and above ceilings, and other concealed spaces that are not intended, nor used, for living purposes, storage or the installation of equipment such as flexible ductwork, heating and refrigeration equipment, are not required to be protected by sprinklers.

Roof and ceiling spaces that contain only items such as electrical wiring for light fittings and exhaust fans, etc are not required by this provision to be provided with sprinklers.

Specification E1.8**Fire control centres****Deemed-to-Satisfy Provisions****1 Scope****Intent**

To clarify that [Specification E1.8](#) provides the construction and content details for fire control centres and rooms.

Fire control centres or rooms

[Specification E1.8](#) sets out the construction and content details for fire control centres and rooms required by the BCA.

A fire control room is a fire control centre in a dedicated room with specific requirements. See [Clause 6](#) which requires that where a fire control centre is in a building of more than 50 metres in effective height, the centre must be in a separate room. Clauses 2 to 5 of [Specification E1.8](#) set out the requirements for fire control centres (including fire control rooms) while Clauses 6 to 12 set out additional requirements for fire control centres which are required to be located in a dedicated room, which is commonly referred to as a fire control room.

2 Purpose and content**Intent**

To clarify the facilities a fire control centre must contain.

Fire control centre required by E1.8

[E1.8](#) sets out when a fire control centre is required in a building.

Exclusive purpose of centre

[Clause 2](#) sets out that a fire control centre must be for the exclusive purpose of:

- directing firefighting operations and other functions of the fire brigade, such as search and rescue operations (this requirement reflects the importance placed on fire brigade operations); and
- other measures directly relating to occupant safety or security.

In this context, the centre or room cannot be used for any other purpose.

3 Location of fire control centre**Intent**

To require that a fire control centre be conveniently placed to allow egress.

Egress

Egress from the fire control centre must not involve a change in level exceeding 300 mm. This is to help fire brigade officers carrying their equipment and make entry easy.

4 Equipment not permitted within fire control centre**Intent**

To limit the type of equipment allowed in a fire control centre.

Extraneous equipment not allowed

Since the fire control centre will be occupied by fire brigade personnel during a fire, possibly for a period long after the other occupants have evacuated, it must be suitable for directing fire brigade operations. Equipment which does not assist in this function, or could endanger the fire brigade personnel, is not allowed in the centre.

5 Ambient sound level for a fire control centre

Intent

To minimise the risk of the sound levels in a fire control centre interfering with the room's function.

Noise must not interfere with communications

The fire control centre is used to direct fire brigade operations during a fire in the building, possibly for a period long after the other occupants have evacuated. This involves communication with other fire brigade officers outside the centre. It is therefore important that ambient sound levels do not interfere with that communication.

6 Construction of fire control room

Intent

To set out the construction details of fire control rooms.

Buildings over 50 metres in effective height

[E1.8](#) requires certain buildings to contain a fire control centre. Clause 6 only applies to those buildings with an effective height greater than 50 metres. In these buildings, a fire control centre must be within a dedicated room known as a fire control room. Since the fire control room will be occupied by fire brigade personnel during a fire in the building, it must be fire separated from the remainder of the building.

7 Protection of openings in a fire control room

Intent

To require that the fire-resisting performance of a fire control room is maintained.

Openings must be fire protected

The aim of [Clause 7](#) is similar to [Clause 6](#), except that [Clause 7](#) deals with openings in the construction separating the fire control room from the remainder of the building.

8 Doors to a fire control room

Intent

To require adequate access to a fire control room.

Application

Refer to comment on [Clause 1](#).

Access

The main provisions deal with access to the fire control room. Since it will be necessary for the fire brigade to gain access to the fire control room while the building is being evacuated, access to it must not be obstructed by people evacuating.

Providing access by way of two paths of travel is to help fire brigade access. One of those paths must be from the front entrance of the building, and the other must be from a public place or a fire-isolated passage which leads from a public place.

9 Size and contents of a fire control room

Intent

To set out the contents required in a fire control room.

Application

Refer to comment on [Clause 1](#).

[Clause 9\(a\)](#) sets out the minimum size and contents required in a fire control room.

[Clause 9\(b\)](#) lists additional items which may be contained in a fire control room. This list is not exhaustive, other

Services and equipment

items may be added provided the floor area of the room is increased, as required by [Clause 9\(c\)](#). [Clause 9\(c\)](#) sets out the area requirements for fire control rooms.

10 Ventilation and power supply for a fire control room

Intent

To reduce the likelihood of smoke accumulating in a fire control room.

Application

Refer to comment on [Clause 1](#).

Since the fire control room will be occupied by fire brigade personnel, possibly for a period long after the other occupants have evacuated, it must have adequate means of preventing the accumulation of smoke. The room can have either natural ventilation complying with [Clause 10\(a\)](#) or a pressurisation system complying with [Clause 10\(b\)](#).

If natural ventilation is used, then the window or door must not open to another part of the building.

If a pressurisation system is used, it must comply with AS 1668.1 and the other provisions of [Clause 10\(b\)](#). This is achieved by treating the room similarly to a fire-isolated stairway, which includes:

- activation of the system;
- air change rates;
- protection of fans, motors and duct work;
- protection of the electrical supply to the system; and
- relief air devices.

11 Sign for a fire control room

Intent

To require that a fire control room is appropriately identified.

Application

Refer to comment on [Clause 1](#).

[Clause 11](#) achieves the intent by requiring the placement of a sign on the door to the room. Such a sign is required on all doors to a fire control room.

12 Lighting for a fire control room

Intent

To provide sufficient illumination to the fire control room during an emergency.

Application

Refer to comment on [Clause 1](#).

Since the fire control room will be occupied by fire brigade personnel during a fire in the building, possibly for a period long after the other occupants have evacuated, it must have appropriate levels of lighting. As the lighting must be maintained while the room is in use, it must be emergency lighting in case of failure of the building's normal lighting system.

Normally, emergency lighting is only used for evacuation purposes. A fire control room is used to direct fire brigade operations, which will include such actions as reference to building plans, and the reading of other information. The amount of emergency lighting in the room must therefore be increased to 400 lux.

Part E2 Smoke hazard management

Objective

EO2

The Objective of this Part is to—

- (a) safeguard occupants from illness or injury by warning them of a fire so that they may safely evacuate; and
- (b) safeguard occupants from illness or injury while evacuating during a fire.

Safeguard occupants from illness and injury

Part E2 aims to safeguard building occupants from illness or injury from the products of combustion (including smoke and toxic gases). **EO2(a)** deals with warning of a fire and **EO2(b)** deals with requirements for evacuating.

Smoke and toxic gases kill

Smoke and toxic gases are the main causes of death in building fires. Such deaths have occurred in locations remote from the fire to where smoke and gases have spread. Smoke and toxic gases cause disorientation, incapacitation and ultimately death, depending on the concentration and length of exposure.

Management of the smoke and toxic gas hazard is crucial for occupant safety. This is best achieved through a combination of active and passive measures, such as:

- building materials and finishes;
- compartmentation;
- egress;
- smoke and toxic gas detection;
- fire suppression; and
- smoke and toxic gas control by mechanical means.

Part E2 addresses some of the active measures which, together with the relevant provisions in other Parts of the BCA, provide appropriate strategies for the protection of occupants.

Functional Statements

EF2.1

A building is to be provided with safeguards so that—

- (a) occupants are warned of a fire in the building so that they may safely evacuate; and
- (b) occupants have time to safely evacuate before the environment in any evacuation route becomes untenable from the effects of fire.

Buildings—adequate safeguards

EF2.1 requires that a building have safeguards to warn occupants of a fire so they may safely evacuate before the conditions in any evacuation route become untenable, due to the effects of fire.

Performance Requirements

EP2.1 Automatic warning for sleeping occupants

Sleeping accommodation—smoke alarms

A Class 2, 3, 9a and 9c building and a Class 4 part must contain automatic warning on the detection of smoke for occupants in sleeping areas, so they may be alerted to a fire.

EP2.2 Safe evacuation routes

Evacuation routes must remain tenable

Occupants must be given time to evacuate before the onset of untenable conditions. **EP2.2(a)** specifies these conditions

Services and equipment

as dangerous temperatures, low visibility and dangerous levels of toxicity.

Hence, evacuation time must take account of a range of factors including the following:

- [EP2.2\(b\)\(i\)](#)—the difficulty of evacuation and/or rescue. An example is where there is a large number of occupants, or they are not mobile, such as patients in a hospital or residents of an elderly people’s home. Here the evacuation time could be high.
- [EP2.2\(b\)\(ii\)](#)—the likelihood or risk of a fire occurring in the building, which can have an influence on risk levels during evacuation and along the evacuation route.
- [EP2.2\(b\)\(iii\)](#)—the time necessary to travel to an exit, and the difficulty of evacuation and/or rescue.
- [EP2.2\(b\)\(iv\)](#), [\(v\)](#) and [\(vi\)](#)—the size, load or intensity of any fire in the building, which has a clear influence on the speed of fire development and spread, and heat and toxic gas characteristics.
- [EP2.2\(b\)\(vii\)](#)—the fire safety systems in the building can influence the rate of fire spread and intensity and toxic gas development (eg if a sprinkler system is installed, it should extinguish the fire or reduce its growth rate).
- [EP2.2\(b\)\(viii\)](#)—the firefighting operations of the fire brigade and the resources available to it, which influences the extent to which a fire can develop before the fire brigade is likely to bring it under control.

Under its Limitation provision, [EP2.2](#) does not apply to open-deck car parks or open spectator stands where the smoke and hot gases can vent naturally, thereby allowing occupants to safely evacuate.

Part E2 Smoke hazard management

Deemed-to-Satisfy Provisions

E2.0 Deemed-to-Satisfy Provisions

Intent

To clarify that the requirements of [EP2.1](#) and [EP2.2](#) will be satisfied if compliance is achieved with [E2.1](#) to [E2.3](#) in the case of all buildings, [Part G3](#) in the case of buildings with an atrium, [Part G4](#) in the case of buildings in alpine areas, [Part H1](#) in the case of theatres, stages and public halls.

[E2.1 to E2.3](#) and [EP2.1](#) and [EP2.2](#)

Where a solution is proposed to comply with the Deemed-to-Satisfy Provisions, except in buildings containing atriums, compliance with [E2.1](#) to [E2.3](#) achieves compliance with [EP2.1](#) and [EP2.2](#).

Buildings with atriums

In addition to achieving compliance with [E2.1](#) to [E2.3](#), to achieve compliance with [EP2.1](#) and [EP2.2](#) buildings with atriums must also comply with [Part G3](#).

Where a Performance Solution is proposed, the relevant Performance Requirements must be determined in accordance with [A2.2\(3\)](#) and [A2.4\(3\)](#) as applicable. (See commentary on [Part A2](#)).

E2.1 Application of Part

Intent

To specify when [E2.2](#) and [E2.3](#) do not apply.

Open-deck carpark, open spectator stands and Class 8 electricity network substations—[E2.1\(a\)](#)

[E2.1\(a\)](#), [E2.2](#) and [E2.3](#) do not apply to open-deck carpark or open spectator stands. [EP2.2](#) does not apply to such buildings because the smoke and hot gases can vent naturally.

The Deemed-to-Satisfy Provisions of [Part E2](#) do not apply to small Class 8 electricity network substations, located in a multi-classified building. These smaller substations are usually located within a “host” building and the associated electrical equipment has its own sensitive dedicated systems that provide a rapid response signal to a central control room that is constantly staffed.

Smoke exhaust systems and smoke-and-heat vents—[E2.1\(b\)](#)

Under [E2.1\(b\)](#), the [E2.2](#) and [E2.3](#) provisions regarding smoke exhaust systems and smoke-and-heat vents do not apply to small areas used for short periods.

A small area will be easily evacuated before smoke build-up and if the area is only used for short periods, the risk of occupants being trapped in it during a fire is low.

E2.2 General requirements

Intent

To specify the requirements for minimising the smoke risks.

Class 2–9 buildings—[E2.2\(a\)](#)

Class 2–9 buildings must comply with [E2.2\(b\)](#), (c) and (d), which cover the fire mode operation of air-handling systems so that they do not contribute to the spread of smoke during a fire. This assists to maintain the basic smoke integrity of the fire compartments.

In addition to [E2.2\(b\)](#), (c) and (d), Class 2–9 buildings must comply with the requirements of [Table E2.2a](#), which provides some general and specific strategies for smoke hazard management.

In addition to [E2.2\(b\)](#), (c) and (d) and [Table E2.2a](#), Class 6 and Class 9b buildings must comply with the requirements of [Table E2.2b](#), where applicable, which provides some general and specific strategies for smoke hazard management.

Air-handling system which is not part of a smoke hazard management system—[E2.2\(b\)](#)

Smoke must not cross smoke barriers

Services and equipment

E2.2(b) requires that an air-handling system that is not part of a smoke hazard management system be designed and installed with suitable strategies to ensure that, during a fire, it does not:

- recycle air (and therefore smoke) from one fire compartment to another; or
- otherwise contribute to the spread of smoke between fire compartments.

Comply with AS 1668.1—E2.2(b)(i)

The effect of **E2.2(b)(i)** is that in a fire, an air-handling system must either operate as a smoke control system in accordance with AS 1668.1 (as specified in **E2.2(b)(i)**) or shut down (as specified in **E2.2(b)(ii)**).

A smoke purging system, in accordance with AS 1668.1, is allowable in buildings not covered by the general provisions in **Table E2.2a**, and, in some instances, in conjunction with other measures in accordance with **Table E2.2a**.

Non-smoke control system—E2.2(b)

An air-handling system not designed as a smoke control system must comply with the requirements set out in **E2.2(b)** as follows:

- Automatic smoke dampers—**E2.2(b)(ii)(A)**

Where the air-handling system is shut down in fire mode, it must incorporate automatic smoke dampers where the ducts penetrate any fire barriers.

This requirement may apply to an air-handling system which supplies outside air to a group of residential sole-occupancy units.

- System shut down—**E2.2(b)(ii)(B)**

The air handling system must shut down, and smoke detectors must automatically activate smoke dampers.

- Class 2 and Class 3 buildings

Sole-occupancy units in Class 2 and Class 3 buildings are, under **E2.2(b)**, regarded as separate fire compartments.

Sections 5 and 6 of AS 1668.1—E2.2(c)

Air-handling systems, other than one in a carpark, serving more than one fire compartment covered by Sections 5 and 6 of AS 1668.1 must be designed and installed in compliance with those sections of the Australian Standard. This will restrict the spread of smoke between fire compartments.

Provisions on the operation of carpark ventilation systems during a fire in the carpark are included under the general provisions in **Table E2.2a**.

Smoke detection systems to operate AS 1668.1 smoke control systems—E2.2(d)

An AS 1668.1 system for zone pressurisation and automatic air pressurisation for fire-isolated exits must be controlled by a smoke detection and alarm system installed in compliance with **Specification E2.2a**. Activation of these systems also requires the activation of a building occupant warning system.

E2.3 Provision for special hazards

Intent

To state that some special hazards may require additional smoke hazard management measures.

Additional smoke hazard measures

E2.3 states that certain factors may need additional smoke hazard management measures.

E2.3 reinforces the need for careful consideration and sound professional judgement in the application of the smoke hazard management provisions of the BCA.

Examples

E2.3 may be applicable in situations where:

- A child care centre is located above ground floor level or within a commercial building. Safety of children is paramount. They will need assistance to evacuate. As egress arrangements depart from providing exits direct to a road or open space, (usually provided at ground floor level) so does the potential for things to go wrong. The BCA does not specifically address child care centres at other than the ground floor.
- Occupants are held under detention in a correctional or health-care facility. The BCA does not specifically address the special circumstances surrounding these facilities. To ensure an acceptable level of safety is provided to occupants, special provisions may need to be provided.
- A high hazard process is carried out in an industrial building. Due to the variance in such processes, it would

Services and equipment

be difficult to develop specific generic provisions. Such processes may also be subject to other legislation. Hence each process should be considered on its merits and additional safeguards provided as necessary.

Deemed-to-Satisfy Provisions—[Tables E2.2a](#) and [E2.2b](#)

Table E2.2a—General Provisions

Table E2.2a and EP2.1 and EP2.2

[EP2.1](#) requires automatic warning on the detection of smoke in buildings having sleeping accommodation, so that occupants may be alerted to the fire hazard. [EP2.2](#), in terms of maintaining safe conditions in any evacuation route, deals with the period of time it would take occupants to evacuate that part of the building.

Table E2.2a provides whole-building strategies

[Table E2.2a](#) provides smoke hazard management strategies structured to help application to buildings of mixed classification. In the case of a multi-classified building, each classifiable part must comply with the relevant provisions for its classification. Certain Class 6 and Class 9b parts of buildings must also comply with the specific provisions in [Table E2.2b](#).

Table E2.2a Zone pressurisation systems

Where zone pressurisation systems are specified in various locations in [Table E2.2a](#) to be in accordance with AS 1668.1, the provision states that zone pressurisation systems only apply between vertically separated fire compartments and not horizontal fire compartments.

Fire-isolated exits

Fire-isolated exits enable the safe evacuation of occupants, and also aid fire brigade access. Smoke must not unduly affect the conditions in such exits during an evacuation.

To minimise smoke intrusion, the exits may need to be pressurised with outside air for the entire exit route. See the following examples. Alternatively, the exits may be provided with open access ramps or balconies from which smoke can vent naturally.

Examples

Pressurised fire-isolated exits are required where:

- tenable conditions must be maintained for an extended period due to a long distance of travel, such as exits which serve storeys above 25 metres in effective height or which are more than 60 metres in length to a road or open space;
- tenable conditions must be maintained for an extended period of time to enable the safe evacuation of non-ambulatory occupants, such as in health-care buildings with a rise in storeys of more than 2;
- the exits are the only possible means of escape, such as those serving basements more than two storeys below ground; or
- the risk of smoke intrusion into the exits is high on account of a particular building characteristic, such as is generally the case in a building containing an atrium.

Buildings over 25 metres in effective height

In buildings more than 25 metres in effective height, tenable conditions need to be maintained in the fire-isolated exits and, where practicable, in other parts of the building to enable the staged evacuation of occupants.

Occupants of such buildings may continue to occupy compartments remote from the fire for an extended time before evacuation. Accordingly, suitable measures must be adopted to minimise the spread of smoke from the fire-affected compartment to non-affected compartments by way of a number of potential leakage paths.

These paths include lift shafts, air-handling ducts, services risers, building penetrations, spandrels, and the like, through which smoke can be driven by buoyancy, expansion, stack and wind effects, and air-handling systems.

In order to minimise the spread of smoke, a zone pressurisation system is considered necessary in buildings more than 25 metres in effective height. This does not apply to the residential parts of a building in view of:

- the alternative protection provided by the fire compartmentation of sole-occupancy units;
- separation of public corridors by bounding construction; and
- division of such corridors by smoke-proof walls into lengths of not more than 40 metres (see [C2.14](#)).

Additionally, this requirement does not apply to a building that contains only one single fire compartment containing a Class 5, 6, 7b, 8 or 9b part (or a combination of these classes in the same fire compartment) in an otherwise Class 2, 3, 9a or 9c building. Reference to a Class 2, 3, 9a or 9c building does not include a building that also contains a Class 7a carpark (see [Figure E2.2a](#)). The reasons for this exemption are:

Services and equipment

- the provision of a zone pressurisation system is considered inappropriate for a single compartment in a building; and
- any single fire compartment Class 9b building or Class 6 building with a floor area greater than 2000 m² is also subject to the provisions of [Table E2.2b](#), ensuring that smoke hazard management considerations are applied; and
- to require compliance could create an anomaly with the exemption of sporting complexes, including gymnasiums and swimming pools from required smoke hazard management measures under [Table E2.2b](#).

Notwithstanding the above, a smoke detection and alarm system must be provided in residential and health-care buildings to provide early warning to occupants who may be asleep, confused, or non-ambulatory and dependent on assistance.

Figure E2.2a Zone pressurisation concession

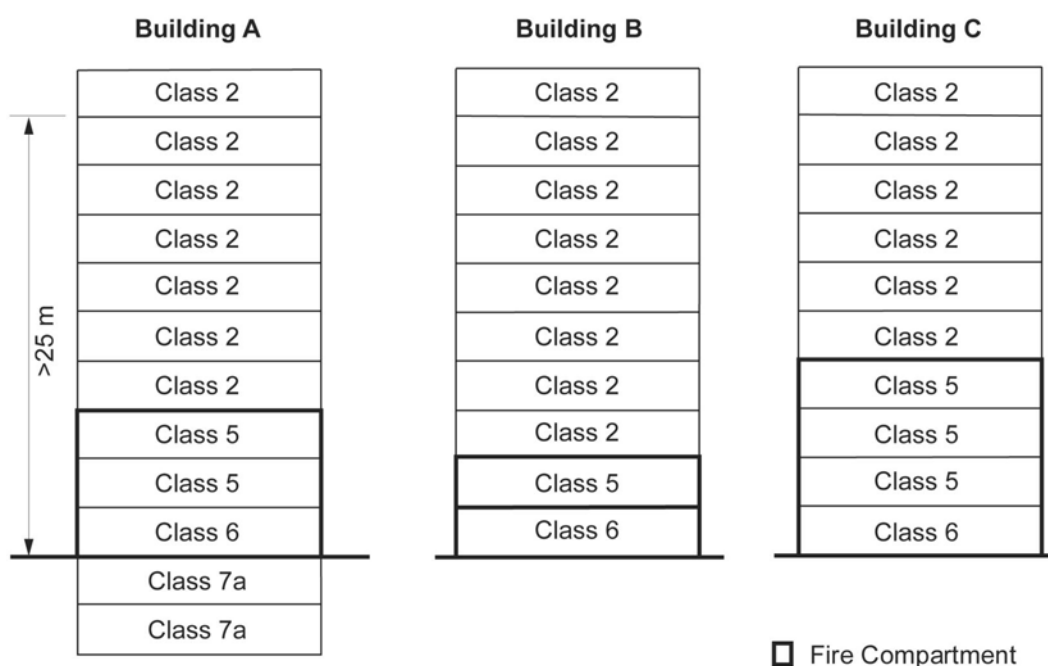

- Building A** Although the building has only one fire compartment containing a Class 5, 6, 7b, 8 or 9b part, the concession does not apply because the building contains a Class 7a part.
- Building B** A zone pressurisation system is required because the building contains more than one fire compartment containing a Class 5, 6, 7b, 8 or 9b part.
- Building C** A zone pressurisation system is not required because the building has only one fire compartment containing a Class 5, 6, 7b, 8 or 9b part and the remainder of the building is solely Class 2.

[Table E2.2a](#) provisions are additional to other safety provisions for buildings with an effective height of more than 25 metres.

Buildings less than 25 metres in effective height

In buildings less than 25 metres in effective height, the necessary levels of protection may be achieved by measures other than zone pressurisation, depending on the Class and rise in storeys of the building.

In buildings other than health-care buildings, zone pressurisation may be substituted by either stairway pressurisation, smoke detection, or sprinkler protection. The rise in storeys before which the provisions become applicable depends on the building’s classification and use.

The above measures do not apply to the residential parts of a building because of the passive protection provided to such parts. However, where one or more fire-isolated exits join residential and non-residential parts, other than open-deck carparks, the fire-isolated exits must either be pressurised, or the non-residential parts provided with smoke detection or sprinkler protection. This is necessary to compensate for the potential additional hazard associated with the particular mix of Classes.

In health-care buildings, zone pressurisation may be substituted by a sprinkler system, providing residential sprinkler heads are used in patient care areas. The fast response of residential sprinkler heads promotes life safety by limiting fire growth and smoke development. Where zone control is not adopted, the air-handling systems must generally be shut down not only to maintain the integrity of the smoke and fire compartmentation, but also to minimise the spread of smoke

Services and equipment

within the fire-affected compartment.

Notwithstanding the above, a smoke detection and alarm system must be provided in residential and health-care buildings.

Large Class 7 or 8 buildings subject to C2.3

These provisions set out the smoke hazard management measures for large isolated Class 7 or 8 buildings subject to the requirements of C2.3(a) with a floor area of 18 000 m² or less and a volume of 108 000 m³ or less. Such buildings are required to have:

- a sprinkler system (see Specification E1.5 for details) and be provided with perimeter vehicular access complying with C2.4(b);
- an automatic fire detection and alarm system (see Clause 7 of Specification E2.2a for details);
- an automatic smoke exhaust system (see Specification E2.2b for details);
- automatic smoke and heat vents (see Specification E2.2c for details); or
- natural smoke venting (see Table E2.2a for details).

Large Class 5 to 9 buildings subject to C2.3

These provisions set out the smoke hazard management measures for large isolated Class 5 to 9 buildings subject to the requirements of C2.3(b) having a floor area exceeding 18 000 m² or having a volume exceeding 108 000 m³.

Such buildings are required to have:

- where there is a ceiling height of 12 metres or less, either a specified automatic smoke exhaust system (see Specification E2.2b for details), or an automatic smoke-and-heat ventilation system (see Specification E2.2c for details); or
- where there is a ceiling height of more than 12 metres, a specified automatic smoke exhaust system (see Specification E2.2b for details).

Roller shutters

Roller shutters and doors can be used for smoke venting purposes in accordance with the table if they are “readily openable”. A building proponent must satisfy the appropriate authority that such roller shutters and doors achieve the “readily openable” requirement.

However, if the openings are also used for egress purposes, they must also comply with the requirements of relevant provisions such as D2.19 and D2.21.

Class 7a buildings

A carpark ventilation system is consistent with the treatment of miscellaneous air-handling systems in AS 1668.1. Accordingly, the electric power and control cabling for a carpark ventilation system need not be fire rated.

Likewise, a concession is granted to allow fans with metal blades suitable for operating at normal temperatures to be used instead of fans required to operate at elevated temperatures as required by Clause 4.8.1 of AS 1668.1.

To make sure that the manual override provision of Clause 5.5.3 of AS 1668.1 is not subject to the control of any general installation main switches, the power supply arrangement must comply with AS 3000.

Basements (other than Class 7a buildings)

The provisions for basements are more stringent due to the special problems they pose for evacuation, search and rescue, and firefighting operations.

As the total floor area of the basement increases to above 2 000 m², certain minimum measures have been stipulated. In basements with three or more below ground storeys, a sprinkler system is considered necessary.

Atriums

The provisions of this Part, as well as Part G3, apply to atrium buildings.

Table E2.2b—Specific Provisions

Table E2.2b and Class 6 and Class 9b buildings

The provisions of Table E2.2b are additional strategies which only apply to certain Class 6 and Class 9b buildings where there is a high risk that occupants may not be able to safely evacuate the fire-affected compartment. This risk may be due to factors such as:

- building design;
- function;
- usage;
- fire load; or
- nature of occupancy.

Services and equipment

Occupants of such buildings are also not necessarily familiar with the building or the procedures for evacuation.

Maintenance of safe conditions in evacuation routes

Table E2.2b addresses requirements under EP2.2 in terms of maintaining safe conditions in any evacuation route within the fire-affected compartment of Class 6 and Class 9b buildings, for the period of time it would take occupants to evacuate that part of the building.

Class 6 buildings

There are specific provisions for large Class 6 buildings in Table E2.2b for the installation of either an automatic smoke exhaust system or automatic smoke-and-heat vents to control smoke during a fire. These apply to the whole fire compartment where the floor area of the Class 6 part of the fire compartment is more than 2 000 m².

There are specific concessions that vary these requirements. These are—

- for buildings where the floor area of the fire compartment does not exceed 3 500 m², it is permitted to install—
 - an automatic smoke detection and alarm system in lieu of a smoke exhaust or smoke venting system if the building is single storey; or
 - a sprinkler system if the building has a rise in storeys of not more than 2.
- for single storey shops with a floor area less than 2 000 m² (within a larger fire compartment) which have a main entrance opening to a road or open space and are smoke separated from the fire compartment. See **Example 1**.
- for another part of the building with a different classification (i.e. other than Class 6) which is smoke separated, including openings, junctions and joints of building elements, etc., from the Class 6 part.

Example 1

Example 1 looks at a single storey shopping complex which does not contain a mall, as shown in Figure E2.2b(1). The fire compartment has a floor area of 5 300 m², so smoke exhaust/venting is required. The floor area of the fire compartment is more than 3 500 m², therefore a smoke detection and alarm system or a sprinkler system cannot be used in lieu of smoke exhaust venting. However, smoke exhaust venting need not be provided in shops A and C because their individual floor areas are less than 2 000 m², they are not interconnected to shop B, and their main entrances open to a road or open space.

Smoke exhaust or smoke-and-heat venting must be provided to shop B.

Example 1: Single storey shopping complex not containing a mall

Shop	Area	Entry	Smoke exhaust OR smoke-and-heat vents OR smoke detection and alarm OR sprinkler system
A	900 m ²	From open space	None required
B	2 500 m ²	From open space	Smoke exhaust or smoke-and-heat venting required as the floor area exceeds 2 000 m ²
C	1 900 m ²	From open space	None required

Services and equipment

Figure E2.2b(1) Plan of shopping centre for Example 1

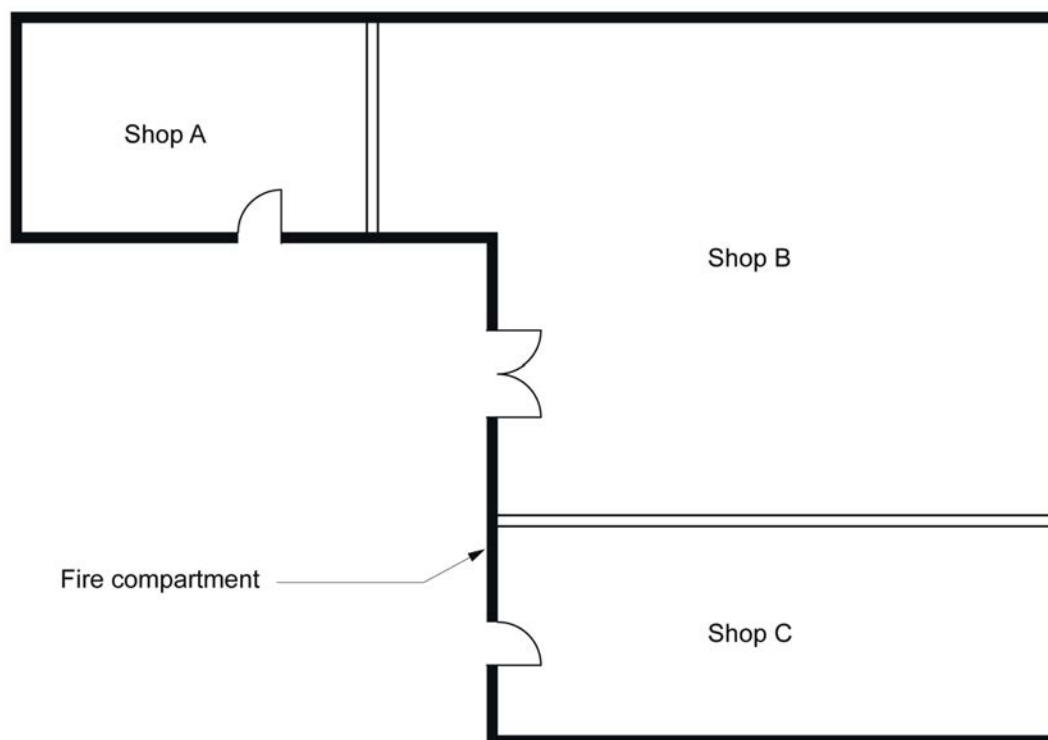

The specific smoke hazard management provisions for Class 6 buildings containing shops and an enclosed common walkway or mall are similar. Where such a building has a fire compartment with a floor area of more than 2 000 m², an automatic smoke exhaust system or an automatic smoke-and-heat vent system to control smoke during a fire is required.

However, where a single storey shop does not open onto the mall and its main public entrance opens to a road or open space, it does not need to have any smoke exhaust or smoke venting, if its floor area does not exceed 2 000 m². This is similar to the concession for a shop in a building which does not contain a mall.

Another concession applies to shops that open onto the mall. They do not need to have any smoke exhaust or smoke venting system if their individual floor areas are less than 1 000m².

A concession is also available for another part of the building with a different classification (i.e. other than Class 6) which is smoke separated, including openings, junctions and joints of building elements, etc., from the Class 6 part.

In a Class 6 building containing a mall, a sprinkler system can also be used in lieu of a required automatic smoke exhaust system or an automatic smoke-and-heat vent system, if the floor area of the whole fire compartment is not more than 3 500 m².

Example 2

Example 2 looks at a single storey shopping complex containing a mall, as shown in [Figure E2.2b\(2\)](#). The fire compartment is 15 900 m², therefore smoke exhaust/venting is required (if the floor area of the fire compartment had been less than 3 500 m², a sprinkler system could have been used instead of a smoke exhaust/venting system). Smoke exhaust or venting is not required to shop B, which opens onto the mall, because the floor area is less than 1 000 m². It is also not required to shop D, because the floor area is less than 2 000 m², it does not open onto the mall, and the main entrance is to a road or open space.

Example 2: Single storey shopping complex containing a mall

Shop	Area	Entry	Smoke exhaust OR smoke-and-heat vents
A	900 m ²	From open space	None required as it is single storey, the floor area is less than 2 000 m ² and the main entrance opens to a road or open space
B	900 m ²	From mall	None required as the floor area is

Services and equipment

Shop	Area	Entry	Smoke exhaust OR smoke-and-heat vents
			less than 1 000 m ²
C	900 m ²	From mall and open space	None required as the floor area is less than 1 000 m ²
D	1 900 m ²	From open space	None required as it is single storey, the floor area is less than 2 000 m ² and the main entrance opens to a road or open space
E	1 900 m ²	From mall	Required as the floor area is over 1 000 m ² and opens onto mall
F	1 900 m ²	From mall and open space	Required as the floor area is over 1 000 m ² and opens onto mall
G	2 500 m ²	From open space	Required as the floor area is more than 2 000 m ²
H	2 500 m ²	From mall	Required as the floor area is over 1 000 m ² and opens onto mall
I	2 500 m ²	From mall and open space	Required as the floor area is over 1 000 m ² and opens onto mall
Mall	—	—	Required as the fire compartment has a floor area over 2 000 m ²

Figure E2.2b(2) Plan of shopping centre for example 2

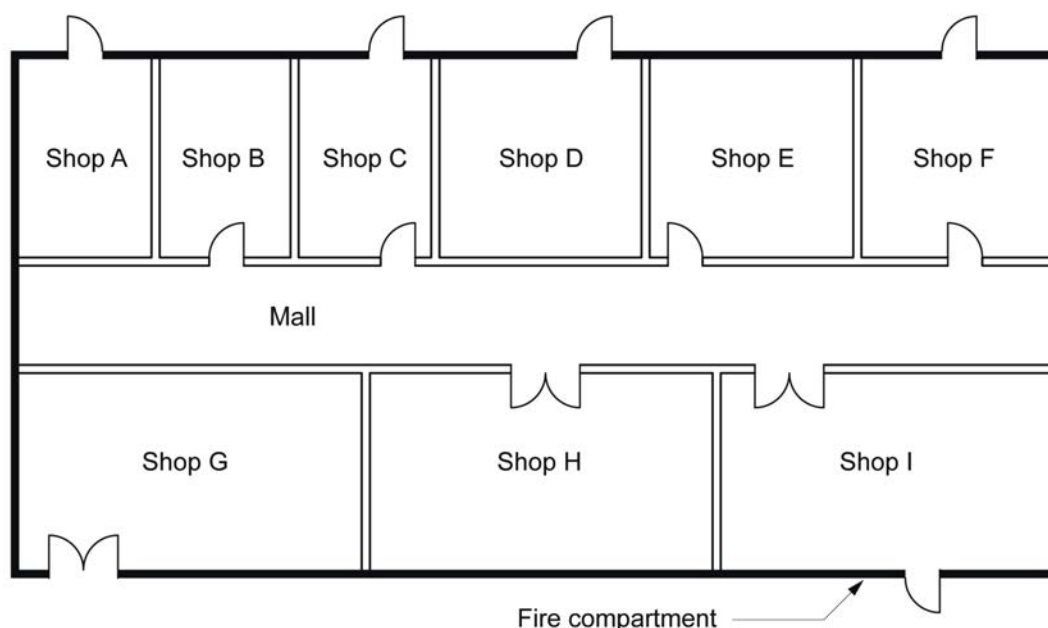

Class 9 assembly buildings

Table E2.2b —greater uniformity and consistency

Assembly buildings cover a wide range of uses with varying degrees of hazards. Table E2.2b addresses some of the uses to enable greater uniformity in the treatment of the buildings or parts of buildings. It provides for assembly buildings generally, except for certain low hazard occupancies which have been exempted from compliance.

Exempted assembly buildings

Certain Table E2.2b provisions for assembly buildings do not apply to schools, apart from the automatic shutdown of air-handling systems in lecture theatres. This is because such buildings may have alarm systems with which the occupants are familiar, and the occupants are usually under a sufficient level of control to enable quick and orderly evacuation.

Concessions are granted for sporting complexes, excluding indoor stadiums with total spectator seating of more than 1000, principally because the risk levels are not high, particularly with regard to open-air complexes. Buildings used solely

Services and equipment

for religious worship are also exempt.

Assembly buildings with floor area over 2000 m²

The [Table E2.2b](#) provisions for smoke exhaust or smoke-and-heat vents are applicable to fire compartments having a floor area of more than 2000 m², except that certain concessions apply to low rise buildings.

If the floor area of the fire compartment is not more than 5000 m², smoke extraction need not be provided if the building has a rise in storeys of two or less, and a smoke detection and alarm system, or a sprinkler system is installed.

Nightclubs, discotheques and the like

The [Table E2.2b](#) provisions apply to all nightclubs, discotheques and the like, regardless of the floor area, in recognition of the high hazards generated by such factors as:

- occupant density;
- access control;
- indoor environment;
- quantity and location of soft furnishings;
- whether or not smoking is permitted; and
- occupant behaviour.

Exhibition halls

The [Table E2.2b](#) provisions for exhibition halls which are used for trade displays and the like are based on them having hazards similar to those for shopping centres and indoor markets.

Theatres and public halls

The [Table E2.2b](#) provisions only apply to those theatres and public halls which are considered a high hazard occupancy due to the potential fire load associated with the stage and backstage areas and/or rigging lofts. Under [Part H1](#), such theatres and public halls are also required to be sprinkler protected or have the stage and backstage areas separated from the audience by a proscenium wall.

The [Table E2.2b](#) provisions for these occupancies are similar to those for assembly buildings. The provision for automatic shutdown of air-handling systems (which do not form part of a smoke management system) is applicable in all such buildings, including those serving school lecture theatres not more than 2000 m² in area.

Other assembly buildings

[Table E2.2b](#) includes provisions for general assembly buildings not covered elsewhere. Museums and art galleries with fire compartments in excess of 2000 m² are covered by these provisions.

Specification E2.2a

Smoke detection and alarm systems

Deemed-to-Satisfy Provisions

1 Scope

Intent

To state that [Specification E2.2a](#) relates to the installation and operation of automatic alarm systems.

Automatic smoke detection and alarm systems

[Specification E2.2a](#) covers the technical requirements for smoke detection and alarm systems, including such detection as is necessary to activate smoke control systems.

2 Type of system

Intent

To specify compliance requirements for required automatic smoke detection and alarm systems.

Types of smoke detection and alarm systems

[Clause 2](#) covers smoke detection and alarm systems directly referenced in [Tables E2.2a](#) and [E2.2b](#). The application of smoke detection to smoke control systems is addressed in [Clause 6](#).

[Clause 2](#) indicates the types of system, in terms of smoke alarm and/or smoke detection, applicable to various Classes of buildings. A smoke detection system is considered necessary in certain Class 3 and Class 9a buildings to facilitate system monitoring as required by [Clause 8](#).

Smoke alarm systems

Smoke alarm systems are required in:

- Class 2 buildings;
- smaller Class 3 buildings (see [Clause 2\(b\)](#) regarding larger Class 3 buildings);
- Class 4 parts; and
- smaller Class 9a buildings (see [Clause 2\(d\)\(i\)](#) regarding larger Class 9a buildings).

Smoke detection systems

Smoke detection systems are required (and in some cases are the sole requirement to satisfy smoke hazard management provisions) in:

- Class 2 buildings;
- smaller Class 3 buildings;
- larger Class 3 buildings;
- Class 4 parts;
- Class 5–8 and Class 9b buildings (note that a smoke detection system complying with [Clause 4](#) and not a smoke alarm system complying with [Clause 3](#) is required in these buildings);
- smaller Class 9a building (see [Clause 2\(d\)\(i\)](#) regarding larger Class 9a buildings);
- larger Class 9a buildings (note that a smoke detection system complying with [Clause 4](#) and not a smoke alarm system complying with [Clause 3](#) is required in these buildings); and
- Class 9c buildings.

Combined systems

Combined smoke alarm and smoke detection systems are permitted (as specified) in:

- Class 2 buildings;
- smaller Class 3 buildings (see [Clause 2\(b\)](#) regarding larger Class 3 buildings); and
- Class 4 parts.

A smoke alarm system and a smoke detection system are only required to be installed when required by [Table E2.2a](#)

or [Table E2.2b](#).

3 Smoke alarm system

Intent

To specify requirements for required automatic smoke alarm systems.

Smoke alarm systems—[Clause 3\(a\)](#)

Smoke alarm systems must include smoke alarms which comply with AS 3786 (see [Clause 3\(a\)\(i\)\(A\)](#)).

Power to smoke alarm systems must come from the electrical power supply to that part of the building served by the smoke alarm system.

Use of other suitable alarms—[Clause 3\(a\)\(ii\)](#)

A smoke alarm can give false alarms if the atmosphere contains particles, such as steam or other vapours, which obscure vision. For example, in a kitchen or a bathroom these conditions may be present. [Clause 3\(a\)\(ii\)](#) therefore allows the use of a more suitable alarm in these locations. It is important that the alarm used is suitable for the location and type of fire likely to occur. The suitability of alarms can be determined by reference to AS 1670.1. The alternative of an alarm acknowledgement facility complying with AS 1670.1 provides occupants with an opportunity to mitigate the effects of spurious or unwarranted alarms.

Smoke alarms and residential buildings—[Clause 3\(b\)](#)

[Clause 3\(b\)](#) details the installation requirements for automatic smoke alarms in residential buildings (excluding Class 9 buildings).

[Clause 3\(b\)\(ii\)](#) requires alarms located within each sole-occupancy unit to be interconnected to provide a common alarm so that if one alarm sounds then other alarms in the sole-occupancy unit automatically activate, which will increase the likelihood of sleeping occupants being aware of the smoke. The word 'alarm' includes any type of alarm allowed under [Clause 3\(a\)\(ii\)\(A\)](#).

Smoke alarms located outside the sole-occupancy units, in public corridors and other common areas within the building, must be interconnected to provide a common building alarm in order to alert all building occupants to the potential hazard in the common evacuation routes.

In buildings which do not contain a sprinkler system complying with [Specification E1.5](#), [Clause 3\(b\)\(iii\)](#) requires smoke alarms to be installed in public corridors and other internal public spaces. Such spaces would include public foyers, reception areas and enclosed car parks. However, these spaces would not include fire-isolated exits, as they are subject to separate smoke hazard management provisions under [Table E2.2a](#).

Smoke alarms and health-care buildings—[Clause 3\(c\)](#)

The application of [Clause 3\(c\)](#) is limited by the provisions of [Clause 2\(d\)](#) to small health-care buildings, where not more than six patients are accommodated in beds.

[Clause 3\(c\)](#) requires smoke alarms to be installed in public corridors and other internal public spaces. Such spaces would include public foyers, reception areas and enclosed car parks. However, these spaces would not include fire-isolated exits, as they are subject to separate smoke hazard management provisions under [Table E2.2a](#).

Interconnection of smoke alarms is required due to the level of compartmentation and the need to alert staff to help occupants who may be confused, non-ambulatory or otherwise dependent on assistance. Manual call points are also necessary in view of the nature of the occupancy.

4 Smoke detection system

Intent

To specify requirements for required automatic smoke detection systems.

Smoke detection systems—[Clause 4\(a\)](#)

[Clause 4\(a\)\(ii\)\(A\)](#) specifies the circumstances in which AS 1670.1 applies.

[Clause 4\(a\)\(ii\)\(B\)](#) specifies that the smoke detection system must activate a suitable building occupant warning system.

Use of other suitable detectors—[Clause 4\(a\)\(ii\)](#)

A smoke detector can give false alarms if the atmosphere contains particles, such as steam or other vapours which obscure vision. For example, in a kitchen or bathroom these conditions may be present. [Clause 4\(a\)\(ii\)](#) therefore allows the use of a more suitable detector in these locations. It is important that the detector used is suitable for the

Services and equipment

location and type of fire likely to occur. The suitability of detectors can be determined by reference to AS 1670.1. The alternative of an alarm acknowledgement facility complying with AS 1670.1 provides occupants with an opportunity to mitigate the effects of spurious or unwarranted alarms.

Residential buildings—Clause 4(b)

Clause 4(b) details the installation requirements for automatic smoke detection systems in residential buildings (excluding Class 9 buildings).

In buildings which do not contain a sprinkler system complying with Specification E1.5 (other than a FPAA101D or FPAA101H system), Clause 4(b)(i)(B) requires smoke detectors to be installed in public corridors and other internal public spaces. Such spaces would include public foyers, reception areas and enclosed carparks. However, these spaces would not include fire-isolated exits which are addressed in Table E2.2a, commercial storerooms, cleaner's rooms, service cupboards or the like.

Clause 4(b)(i)(A) references Clause 3(b)(i) and Clause 3(b)(ii) which require alarms located within each sole-occupancy unit to be interconnected to provide a common alarm so that if one alarm sounds then other alarms in the sole-occupancy unit automatically activate, which will increase the likelihood of sleeping occupants being aware of the smoke. The word 'alarm' includes any type of alarm allowed under Clause 3(a)(ii)(A).

Health-care buildings—Clause 4(c)

Clause 4(c) applies to all Class 9a buildings which have a smoke detection system. Clause 4(c)(i)(A) applies to both within the patient-care area and the path of travel after a person leaves the patient-care area.

Where an area within a health-care building is likely to cause spurious signals, and the area is protected with a sprinkler system complying with Specification E1.5, Clause 4(c)(i) provides a concession to the smoke detector requirements.

Manual call points are required in evacuation routes in view of the nature of the occupancy.

Residential care buildings—Clause 4(d)

In a residential care building, an automatic smoke detection system must be installed in accordance with AS 1670.1. Subject to Clause 4(a) of Specification E2.2a, Clause 3.27 of AS 1670.1 lists areas where detectors are required. Manual call points are also necessary in larger buildings in view of the nature of the occupancy.

5 Combined smoke alarm and smoke detection system

Intent

To specify requirements for combined smoke alarm and smoke detection systems.

Combined smoke alarm and smoke detection systems—Clause 5(a)

Clause 2 specifies the circumstances in which Clause 5 applies.

Clause 5(a)(i) requires smoke alarms which comply with AS 3786 to be located within each sole-occupancy unit in accordance with Clause 3.

In buildings which do not contain a sprinkler system complying with Specification E1.5 (other than a FPAA101D or FPAA101H system), Clause 5(a)(ii) requires smoke detectors which comply with AS 1670.1 to be installed in public corridors and other internal public spaces in accordance with Clause 4.

6 Smoke detection for smoke control systems

Intent

To specify the smoke detection requirements applicable to smoke control systems.

AS 1668.1 systems—Clause 5(a)

Clause 5(a) covers smoke detection associated with AS 1668.1 stair pressurisation systems referenced in Table E2.2a. It requires the installation of additional detectors adjacent to each bank of lift landing doors. Lift shafts form one of the principal paths for smoke spreading between floors in a multi-compartmented building.

Location and sensitivity—Clause 6(b)

Clause 6(b) covers the location and sensitivity of smoke detectors associated with smoke control systems referenced in:

- Table E2.2b, regarding automatic shutdown of air-handling systems.
- Specification E2.2b, regarding the smoke exhaust system.

Activation—Clause 6(c)

Services and equipment

Under [Clause 6\(c\)](#), smoke detectors which activate a smoke control system must:

- form part of the building's AS 1670.1 smoke detection system or be a separate dedicated system; and
- activate a building occupant warning system complying with [Clause 7](#), unless they initiate shutdown of an automatic air-handling system only, in which case they need not activate a building occupant warning system.

7 Building occupant warning system

Intent

To specify the application of building occupant warning systems.

Residential buildings—[Clauses 7\(a\) and \(b\)](#)

Because of the protection provided by the fire compartmentation of sole-occupancy units in residential buildings, it is not mandatory for a building occupant warning system to have sounders or speakers installed within each sole-occupancy unit. Accordingly, [Clauses 7\(a\) and \(b\)](#) provide for the sound pressure levels to be measured at the entry to each sole-occupancy unit.

Residential care and health-care buildings—[Clauses 7\(c\) and \(d\)](#)

[Clauses 7\(c\) and \(d\)](#) provide for the warning signals to be modified in certain areas within residential care and health-care buildings to minimise trauma to occupants who may be confused or immobile. However, in such instances, adequate warning must always be available to staff, carers, employees and the like.

Class 9c buildings—[Clause 7\(e\)](#)

[Clause 7\(e\)](#) requires warning signals to be modified in certain areas within Class 9c buildings to minimise trauma to residents who may be confused or immobile. However, in such instances, adequate warning must always be available to staff, carers, employees and the like. Residential care facilities may contain more than one building. Nevertheless, staff are required to be notified irrespective of their location.

Occupiable outdoor areas

Clause 7 requires a building occupant warning system provided as part of a smoke hazard management system to sound through all occupied areas. An occupiable outdoor area is part of a building, therefore a required occupant warning system must sound in an occupiable outdoor area.

Additional provisions in [E4.9](#)

The separate provisions under [E4.9](#) are for emergency warning and intercom systems for emergency purposes in certain buildings.

8 System monitoring

Intent

To specify the system monitoring requirements in high risk occupancies.

High risk occupancies

[Clause 8](#) specifies the system monitoring requirements in high risk occupancies, to enable a timely and appropriate response by the local fire brigade to emergencies in such buildings as:

- certain residential, health-care and aged care buildings;
- shops and assembly buildings provided with mechanical or natural smoke extraction systems; and
- large uncomparted factories and warehouses.

The Standard referenced for the alarm monitoring system is AS 1670.3.

Specification E2.2b

Smoke exhaust systems

Deemed-to-Satisfy Provisions

1 Scope

Intent

To state that [Specification E2.2b](#) outlines the requirements for mechanical smoke exhaust systems.

Mechanical smoke exhaust systems

[Specification E2.2b](#) contains the requirements for mechanical smoke exhaust systems.

2 Smoke exhaust capacity

Intent

To specify the capacity and exhaust rates required of mechanical smoke exhaust systems.

Height below the smoke layer—[Clause 2\(a\)](#)

[Clause 2\(a\)](#) defines the height to be maintained to the underside of the smoke layer. This height is used to determine the smoke exhaust capacity for various design fires under steady state conditions.

Exhaust rates—[Clause 2\(b\)](#)

[Clause 2\(b\)](#) requires exhaust rates be determined using [Figure 2](#) of [Specification E2.2b](#). It specifies the exhaust rate required relative to the height to the underside of the smoke layer for various fire sizes.

How to use [Figure 2](#) of [Specification E2.2b](#)

The following needs to be known to use [Figure 2](#) of [Specification E2.2b](#):

- The Class of the subject building or part (in the case of Class 9 buildings the use of the building will also need to be considered).
- Whether or not that building or part is to be sprinklered.
- The fire heat release rate measured in megawatts (MW) taken from [Table 1](#) of [Specification E2.2b](#).
- The MW amount is represented in [Figure 2](#) by a specific line which can be identified in the legend inserted in the Figure.

Figure Spec E2.2b Method of measurement of height to the underside of smoke layer

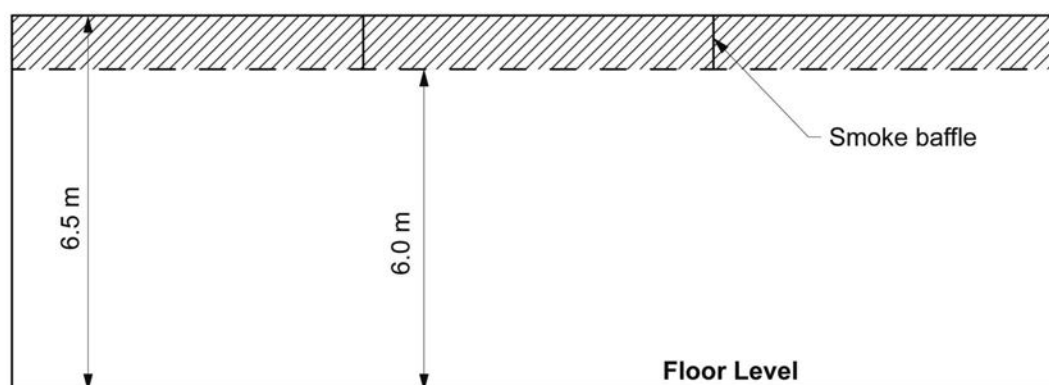

(a) 500 mm baffles

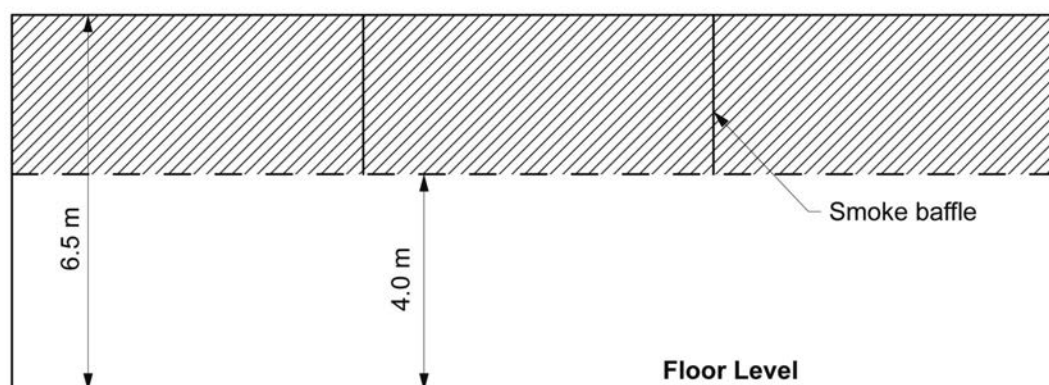

(b) 2.5 m baffles

Smoke exhaust rates

The smoke exhaust rate in [Figure 2 of Specification E2.2b](#) is based on the rate at which air is drawn (i.e. “entrained”) into a plume of smoke which is generally symmetrical around a vertical axis where that plume is rising into the hot layer formed by the smoke reservoir.

The height to the underside of the smoke layer is measured from the highest floor level to the underside of the smoke reservoir. The smoke reservoir’s depth is determined by the depth of the smoke baffles/curtains required by [Clause 4](#). See [Figure Spec E2.2b](#).

3 Smoke exhaust fans

Intent

To specify the operational requirements for smoke exhaust fans.

Operational requirements for smoke exhaust fans

[Clause 3](#) describes the operational requirements for smoke exhaust fans to ensure their design performance is maintained for an appropriate time, when operating in high temperature conditions. Fans must also be rated for ambient temperature operation to facilitate routine maintenance. These provisions also apply to dual purpose fans, that is those used for normal air-handling operations as well as for smoke exhaust.

4 Smoke reservoirs

Intent

To specify the requirements for smoke reservoirs, to enable the containment of smoke in the upper levels of compartments.

Smoke reservoirs—[Clause 4\(a\)](#)

[Clause 4\(a\)](#) requires the division of fire compartments into smoke reservoirs.

Smoke reservoirs are necessary to contain the hot layer in the upper levels of compartments, thus preventing the lateral spread of smoke resulting in excessive cooling and downward mixing of the smoke with the relatively clear layer below which:

- enables occupants to make their way through the comparatively clear air below the hot smoke layer; and
- maintains the smoke above any openings between compartments, thus minimising the risk that smoke will migrate to other areas.

Smoke reservoir dimensions—[Clauses 4\(b\) and \(c\)](#)

Horizontal area to be less than 2000 m²—[Clause 4\(b\)](#)

To maximise the effectiveness of smoke reservoirs, the horizontal area formed by a reservoir is limited by [Clause 4\(b\)](#) to 2000 m².

Maximum length in a shopping mall—[Clause 4\(b\)](#)

The maximum length of a smoke reservoir in a shopping mall is limited by [Clause 4\(b\)](#) to 60 metres, due to the distance people would be expected to travel below a smoke layer while evacuating to a safe place, having regard to the potential for smoke, from a fire in a mall or adjacent specialty shop, to flow into more than one reservoir.

Depth—[Clause 4\(c\)](#)

[Clause 4\(c\)](#) specifies that the smoke reservoir must be of “sufficient” depth to contain the smoke layer.

Bulkhead or smoke baffle—[Clause 4\(d\)](#)

[Clause 4\(d\)](#) deals with the location and depth of a bulkhead or smoke baffle/curtain. Any bulkhead and smoke baffle/curtain must be non-combustible. [Clause 4\(d\)](#) applies only to multi-storey fire compartments.

Smoke needs to be contained within the floor reservoir, and so the integrity of the containment must be maintained at the edges of voids in buildings, such as atriums, by the provision of non-combustible bulkheads or baffles.

5 Smoke exhaust fan and vent location

Intent

To make sure that exhaust fans and vents do not draw clean air up through the smoke layer.

Prevention of “plug-holing”

For a given depth of smoke layer, there is a maximum rate at which smoke can be extracted from a single inlet before air is drawn from below the smoke layer. This is sometimes referred to as “plug-holing”.

Where the smoke layer is relatively shallow, more than one extraction point may be needed to minimise “plug-holing”. It may also be necessary to distribute the extraction points to prevent the formation of stagnant regions leading to excessive cooling and downward mixing of smoke with the relatively clear air below.

Suitable discharge location

It is not suitable for a smoke exhaust fan and vent to discharge adjacent to an occupiable outdoor area.

Specific criteria are not given as the design is dependent on actual building layout.

6 Make-up air

Intent

To provide air to replace that being exhausted by the smoke exhaust system.

Maintenance of the smoke layer—[Clause 6\(a\)](#)

It is necessary to introduce “make-up air” to replace the air being exhausted by the smoke exhaust system, to:

- maintain the smoke layer at a level which keeps a reasonable amount of clear air underneath; and

Services and equipment

- minimise the risk that smoke will flow below the lower levels of the smoke reservoir and migrate to other areas.

Low velocity—Clause 6(b)

Make-up air introduced below the smoke layer must be at relatively low velocities, to minimise any disturbance to the smoke layer. Make-up air introduced at higher velocities may cause:

- smoke to be drawn down from the hot layer, called the “venturi effect”, leading to a loss of visibility in the space below; and
- difficulties for people attempting to exit against the in-rush of air through doorways.

Multi-storey fire compartments—Clause 6(c)

Clause 6(c) deals with the provision of make-up air across any vertical opening from the building void to the fire-affected storey. This aims to minimise the risk of smoke spreading from the fire-affected storey to other storeys.

Non-prescriptive provisions

Specific criteria are not given in Clause 6 as the design is dependent on actual building layout.

7 Smoke exhaust system control

Intent

To specify the control requirements for smoke exhaust systems and automatic make-up air arrangements.

Sequential activation—Clause 7(a)

To make sure that the smoke exhaust fan (or fans) operate in the designed manner, Clause 7(a) requires that the fans are activated sequentially by smoke detectors, and arranged in zones to match the smoke reservoir served by the fan (or fans).

Automatic shutdown—Clause 7(b)

Clause 7(b) requires air handling systems (which generally supply air to upper storeys in high rise buildings) to shut down on the activation of the smoke exhaust system where the air handling system:

- does not form part of the smoke hazard management system;
- is not an individual room unit operating at a rate of less than 1000 L/s; or
- is not a miscellaneous exhaust air system installed in accordance with sections 5 and 11 of AS 1668.1.

This requirement minimises any disturbance to the hot smoke layer and limits smoke being distributed to other non-fire-affected areas of the building by way of the system.

Clause 7(b) is subject to Clauses 7(c) and (d).

Concessions—Clauses 7(c) and (d)

A number of additional concessions to Clause 7(b) are allowed, including:

- Clause 7(c)—systems supplying a single storey fire compartment may supply 100 per cent outside air to the non-fire-affected areas as a means of supplying make-up air for the extraction system serving fire-affected areas; and
- Clause 7(d)—systems supplying a multi-storey fire compartment must supply 100 per cent outside air to the non-fire-affected areas as a means of supplying make-up air for the extraction system serving fire-affected areas.

Override control—Clauses 7(e) and (f)

To allow manual control of the smoke exhaust system by the fire brigade, Clause 7(e) requires an override control to be located adjacent to the fire indicator panel.

In a theatre, an additional manual control must be provided in accordance with Clause 7(f) to allow the stage manager to control the smoke exhaust system during a performance. This is considered necessary because of any special effects which may cause a false alarm.

Electric cabling—Clause 7(g)

To reduce the risk of the smoke exhaust system failing during a fire, Clause 7(g) requires the electric cabling to the system's essential components to be protected from fire in accordance with AS 1668.1.

8 Smoke detection

Intent

To clarify the location of the requirements for the installation of a smoke detection system.

The smoke detection requirements for smoke exhaust systems are addressed in [Clause 5](#) of [Specification E2.2b](#). Such smoke detection systems designed to operate smoke-and-heat vents must also activate an occupant warning system.

Specification E2.2c

Smoke-and-heat vents

Deemed-to-Satisfy Provisions

1 Adoption of AS 2665

Intent

To nominate AS 2665 as the basis for the installation of automatic smoke-and-heat vents, and specify its limitations.

AS 2665

AS 2665 is adopted as the requirement for the installation of a system of automatic smoke-and-heat vents.

Smoke-and-heat vents

Smoke-and-heat vents are dependent on the temperature of the hot smoke layer or the presence of smoke for effective operation. The area of the smoke reservoirs is, therefore, limited by AS 2665 to 1500 m², which is smaller in size than that for mechanical smoke exhaust systems.

It is important to note that the maximum length of a smoke reservoir in a shopping mall is limited to 60 metres due to the distance people travel below a smoke layer while evacuating, having regard to the potential for smoke from a fire in a mall or adjacent specialty shop to flow into more than one reservoir.

AS 2665 requires all smoke-and-heat vents within the same reservoir to operate simultaneously to prevent the formation of stagnant regions leading to excessive cooling and downward mixing of smoke with the clear air below.

In the event of loss of power to operating mechanisms (such as actuators or solenoids), AS 2665 requires smoke-and-heat vents to fail-safe open.

Permanently open vents may be used to replace all or part of the total number of smoke-and-heat vents provided they comply with the relevant parts of AS 2665.

2 Controls

Intent

To specify the controls for automatic smoke-and-heat vents.

Smoke-and-heat vents

Smoke-and-heat vents installed for smoke hazard management purposes in accordance with [Table E2.2b](#) must primarily be initiated on the detection of smoke to enable early operation of the vents.

Where smoke-and-heat vents are installed in Class 7 and Class 8 buildings in accordance with [C2.3\(a\)](#), the operation of the vents by means of fusible links is considered adequate.

The smoke detection requirements for smoke exhaust systems are addressed in [Clauses 6](#) and [8](#) of [Specification E2.2a](#). Such smoke detection systems designed to operate smoke-and-heat vents must also activate an occupant warning system.

Override control

It is important to note that to allow manual control of the smoke exhaust system by the fire brigade, AS 2665 requires an override control to be located adjacent to the fire indicator panel.

Part E3 Lift installations

Objective

EO3

The Objective of this Part is to—

- (a) facilitate the safe movement of occupants; and
- (b) facilitate access for emergency services personnel to carry out emergency procedures and assist in the evacuation of occupants.

All people using a building, including those with disabilities, must be able to travel safely in a lift. Lifts must help emergency services personnel to evacuate sick or injured people. Lifts should also help the fire brigade to transport firefighters and their equipment.

Functional Statements

EF3.1

Where a passenger lift is provided, it is to facilitate safe and easy—

- (a) movement for occupants with a disability; and
- (b) evacuation of occupants, who due to illness or injury need stretcher assistance.

[EF3.1](#) only applies where a passenger lift is provided.

Under [EF3.1\(a\)](#), the lift must be suitable for people with a disability.

EF3.2

A building is to be provided with one or more passenger lifts to facilitate—

- (a) the safe access for emergency services personnel; and
- (b) safe and easy evacuation of occupants who due to illness, injury or disability cannot use stairways in the event of an emergency.

Application:

[EF3.2](#) only applies to—

- (a) a building with an effective height of more than 25 m; and
- (b) a Class 9a building in which patient care areas are located above a level with direct access to a road or open space.

In high-rise buildings and those Class 9a buildings that have patient care areas above road or open space level, a lift must be able to assist emergency services personnel such as:

- ambulance officers carrying equipment to assist a sick or injured person; and
- the fire brigade with equipment.

Lifts in these buildings must also assist with the evacuation of any person unable to use a stairway unassisted.

EF3.3

A building having a passenger lift is to be provided with measures to alert occupants about the use of the lift in an emergency.

Performance Requirements

EP3.1 Stretcher facilities

Under [EP3.1\(a\)](#), where emergency lifts are required under [EP3.2](#), at least one of those required lifts, to the degree

Services and equipment

necessary, must have stretcher facilities. Where there is a single emergency lift it must be the stretcher lift.

Under [EP3.1\(b\)](#), where passenger lifts are provided (and [EP3.1\(a\)](#) does not apply because an emergency lift is not required under [EP3.2](#)), at least one of those passenger lifts must have stretcher facilities.

When a person becomes injured in a building, a stretcher may be needed to evacuate them.

[EP3.1](#) does not contain any specification of what is acceptable as “stretcher facilities”. However, as a guide, [E3.2](#) contains suitable dimensions for a lift car required to accommodate a stretcher.

EP3.2 Emergency lifts

In high-rise buildings (i.e. with an effective height of more than 25 metres), and those Class 9a buildings which have patient care areas above road or open space level, a lift must be available to aid the fire brigade and any other emergency services personnel.

Emergency lifts must service the same floors as any other lift. Therefore, if a level such as a plant-room level does not have any lifts serving it, there is no necessity to provide an emergency lift service to that plant-room level.

EP3.3 Emergency alerts

A suitable notice must be provided, or other measure taken, to alert people about the use of a lift during a fire or other emergency. This applies to all passenger lifts.

EP3.4 Lift access for people with a disability

[EP3.4](#) should be read in conjunction with [Part D3](#). Where access to upper floors is provided by lifts to satisfy [Part D3](#), or where lifts are installed in a building that is required to be accessible under [Part D3](#), those lifts must be suitable for use by people with a disability.

[E3.6](#) provides information on limitations to the use of various types of passenger lifts in certain situations. It also provides information on the size of lift cars and platforms, the application of features such as lighting, door opening widths, handrails and audible and visual information for specific lift types.

Verification Methods

EV3.1 Fire Safety Verification Method

[EV3.1](#) is a means to verify that an automatic warning system complies with [EP3.3](#) to alert occupants about the use of lifts in an emergency, and requires a sound system that activates when a building fire is detected. This method acts as an alternative to the Deemed to Satisfy method of using signage to alert occupants about the use of lifts in an emergency.

[EV3.1](#) nominates that the automatic warning system must be designed to cancel the normal operation of lift call buttons, thereby compelling occupants to use regulated evacuation routes. The automatic warning system must be capable of being manually overridden by emergency personnel in order to minimise any impact on fire-fighting activities.

Part E3 Lift installations

Deemed-to-Satisfy Provisions

E3.0 Deemed-to-Satisfy Provisions

Intent

To clarify that [EP3.1](#) to [EP3.4](#) will be satisfied if compliance is achieved with [E3.1](#) to [E3.8](#) in the case of all buildings, [Part G6](#) in the case of occupiable outdoor areas and, for public transport buildings, [Part H2](#).

[E3.1](#) to [E3.7](#) and [EP3.1](#) to [EP3.4](#)

Where a solution is proposed to comply with the Deemed-to-Satisfy Provisions, compliance with [E3.1](#) to [E3.8](#), [Part G6](#) and [Part H2](#) achieves compliance with [EP3.1](#) to [EP3.4](#).

Where a Performance Solution is proposed, the relevant Performance Requirements must be determined in accordance with [A2.2\(3\)](#) and [A2.4\(3\)](#) as applicable. (See commentary on [Part A2](#)).

E3.1 Lift installations

[E3.1](#) requires that an electric passenger lift and an electrohydraulic passenger lift installation in a building comply with [Specification E3.1](#) for building-related matters. This would include ventilation and lighting of the lift car and foyer access as well as ventilation of the lift shaft.

The conditions in the lift car and the lift shaft machinery are dependant on the conditions in the lift shaft. If the lift shaft air temperature can be elevated due to the effects of the sun, then adequate treatment such as ventilation may be required to maintain safe conditions in the lift shaft along with satisfactory operating temperatures for the lift car machinery and car.

An electric passenger lift may also be a combined electric passenger and goods lift.

An electrohydraulic passenger lift may also be a combined electrohydraulic passenger and goods lift.

E3.2 Stretcher facility in lifts

Intent

To require lifts to be able to accommodate a stretcher.

Under [E3.2\(a\)](#), stretcher facilities are required in one of the emergency lifts required by [E3.4](#). Where no emergency lift is required and passenger lifts are provided, then stretcher facilities are to be provided to one lift serving any storey above an effective height of 12 metres.

Where there is just a single emergency or passenger lift that lift must have stretcher facilities.

[E3.2\(b\)](#) sets out the minimum dimensions of a lift car to accommodate a stretcher. It is allowable to have a protuberance or an openable recess in the lift car to accommodate a stretcher with the dimensions stated.

E3.3 Warning against use of lifts in fire

Intent

To alert people to the dangers of using lifts during a fire.

[E3.3](#) applies to all passenger lifts, even if the building has an effective height of less than 12 metres.

A suitable warning sign must be provided near a lift or lift call button, so that people do not use a lift at an inappropriate time (note that [E3.3\(b\)](#) specifies that such a sign must warn occupants against lift use during a fire).

[E3.3](#) does not apply to small lifts, such as “dumb waiters”, not intended to accommodate a person.

[E3.3\(b\)](#) and [Figure E3.3](#) specify the nature, content, and minimum dimensions for the warning sign. The size and colour of the lettering on the sign are important, so that the sign can be easily read and stand out against the background colour.

Services and equipment

E3.4 Emergency lifts

Intent

To require that lifts be suitable for their purpose and also be available for emergency services personnel.

[E3.4\(a\)](#) to [\(d\)](#) only applies to buildings with an effective height above 25 metres, and in certain Class 9a buildings.

[E3.4\(b\)](#) clarifies that a passenger lift may be used as an emergency lift, provided it satisfies the other provisions of [E3.4](#).

An emergency lift must serve all the floors in a building served by passenger lifts but is not required to serve other floors such as those containing only plant and equipment.

One emergency lift is not required to serve all floors in a building. Just as one bank of passenger lifts may serve certain floors, so may emergency lifts.

[E3.4\(c\)\(i\)](#) requires that where more than one passenger lift serves a floor, at least two emergency lifts must serve that floor.

[E3.4\(c\)\(ii\)](#) requires that if the passenger lifts are in separate shafts, the emergency lifts must also be in separate shafts. This maximises the probability of the emergency lifts operating in an emergency, by minimising the risk that a fire in one shaft will endanger both lifts. It also excludes from its requirements a lift that is within an atrium and not wholly contained within a shaft.

To protect people using an emergency lift during a fire, [E3.4\(d\)](#) requires it to be within a fire-resisting shaft in accordance with the requirements of [C2.10](#).

Appendix A of AS 1735.1 and AS 1735.2 contains specific provisions for emergency lifts. These provisions allow emergency services personnel to override the operation of the lift, including the re-call of the lift to a nominated floor. Note [E3.5](#) with regard to the non-applicability of Clause 12.2 of AS 1735.2.

The [E3.4\(d\)\(ii\)\(A\)](#) dimensions for an emergency lift in a Class 9a building serving a patient care area are to accommodate a stretcher or bed for non-ambulatory patients.

The [E3.4\(d\)\(ii\)\(B\)](#) requirement for an emergency lift in a Class 9a building serving a patient care area to be connected to a standby power supply (if the building has such a system) is in recognition of the risk likely in the event of a power failure.

Under [E3.4\(d\)\(iii\)](#), all emergency lifts serving buildings with an effective height of more than 75 metres must be capable of carrying a weight of at least 600 kg. This recognises the increased difficulties emergency services personnel (particularly fire brigade officers) face in carrying heavy equipment to such heights.

E3.5 Landings

Intent

To require that safe movement be available to and from lift landings.

[E3.5](#) requires access to and egress from lift landings to comply with [Section D](#), including access for people with a disability.

E3.6 Passenger lifts

Intent

To require that lifts necessary for use by people with a disability are suitable.

[E3.6](#) only applies when a passenger lift is required by [D3.3\(b\)](#) for vertical movement of people with a disability. [Table E3.6a](#) details the limitation of each defined type of lift.

[E3.6\(f\)-\(n\)](#) and specific components of AS 1735.12 referenced by the table require passenger lifts to have specific features. There are a number of limitations on the use of stairway platform lifts including that they must not be installed if it is possible to use another type of passenger lift described in [E3.6](#).

Some types of lifts must not be used in high traffic public use areas of certain buildings. For example, a stairway platform lift or a low-rise, low-speed constant pressure lift must not be used at the entry to a theatre. However, these types of lifts may be used to provide access to the stage in a theatre because the access to the stage is not considered to be a high traffic public use area.

Services and equipment

E3.7 Fire service controls

Intent

To require fire service controls for lifts serving any storey above an effective height of 12 m.

By having all lift cars serving any storey above an effective height of 12 m fitted with fire service controls there is no confusion as to which lift car can be used by emergency services personnel, and it also increases the reliability of having an operational lift in the event of an emergency (where more than one lift is provided). This does not require lifts to be increased in size to take a stretcher.

Fire service controls include a fire service recall control switch complying with [E3.9](#) and a lift car fire service drive control switch complying with [E3.10](#).

E3.8 Residential care buildings

Intent

To require the installation of a lift where residents of a Class 9c building are on levels not having access to a road or open space.

[E3.8](#) applies to Class 9c buildings. It requires all levels of residential care buildings to have direct access to a road or open space via a ramp or lift capable of carrying a stretcher. This is to overcome the difficulty experienced by some residents negotiating stairways and enable the use of stretcher facilities on all levels of a residential care building. It also assists with the daily functioning of the building, especially with the use of mobile baths and other equipment.

E3.9 Fire service recall control switch

Intent

To specify the fire service recall control switch required for passenger lifts.

[E3.9](#) details the switch, labelling, key and operation procedures for a fire service recall control switch.

A group of lifts is where a number of lifts are under the same sequence controls.

E3.10 Lift car fire service drive control switch

Intent

To specify the fire service drive control switch required in all passenger lifts.

[E3.10](#) details the switch initiation, labelling and operation for the fire service drive control switch.

A multi-deck installation is a lift car with passengers on more than one deck. The most common multi-deck lift car has two levels opening to two landings at each storey served.

Specification E3.1**Lift installations****Deemed-to-Satisfy Provisions****2 Lift cars exposed to solar radiation****Intent**

To specify the ventilation requirements for a lift car exposed to solar radiation

Lift cars exposed to solar radiation

A lift car may be on the outside of the building in which case it will be exposed to direct solar radiation at some time of the year. However, it may also be in a shaft and in some situations that may be a metal shaft. In this case the sun heats the metal and the metal, in turn, re-radiates the heat to the lift.

An alternate power supply means an alternate source of power to the primary source, in order to enhance the reliability of a system. It may be from a battery bank, from a second power grid connection or from a site generator.

Part E4 Visibility in an emergency, exit signs and warning systems**Objective****EO4**

The Objective of this Part is, in an emergency, to safeguard occupants from injury by—

- (a) having adequate visibility; and
- (b) having adequate identification of exits and paths of travel to exits; and
- (c) being made aware of the emergency.

Provision of visibility, signage and warning

This Objective covers three of the basic elements required to help occupants evacuate a building in an emergency:

- visibility to see the evacuation route;
- signage to indicate the evacuation route; and
- warning of the emergency, so they know they need to evacuate.

Functional Statements**EF4.1**

A building is to be provided with—

- (a) adequate visibility upon failure of normal artificial lighting during an emergency; and
- (b) adequate means—
 - (i) of warning occupants to evacuate; and
 - (ii) to manage the evacuation process; and
 - (iii) to identify exits and paths of travel to an exit.

Visibility in an emergency—EF4.1(a)

Artificial lighting is often one of the first things to fail during a building emergency. This can significantly impair the ability of the occupants to evacuate the building. Accordingly, a building must provide adequate visibility on the failure of artificial lighting in an emergency.

Warning of occupants—EF4.1(b)(i)

Many of the emergency protection systems built into the BCA are time related, particularly those designed to protect occupants from a fire. The effectiveness of this protection may be negated if occupants are not made aware of the need to evacuate. It is essential that adequate early warning systems advise of the need to evacuate the building as soon as possible.

Evacuation management systems—EF4.1(b)(ii)

Emergency evacuation requires all evacuations to maximise the opportunity for occupants to reach a place of safety. Since the BCA generally relates to the construction of a building, rather than its on-going use, it can only require the installation of a system to assist in the management of the evacuation process. It cannot demand, for example:

- training, so that the evacuation process is undertaken automatically;
- allocation of staff to assist with evacuation, particularly if the building is likely to contain occupants who have been unable to benefit from prior training; or
- a detailed evacuation plan.

Identification of exits and paths of travel—EF4.1(b)(iii)

Occupants need to be able to identify their route to safety without hesitation. The emergency route must be signed in a way which is clear and unambiguous.

Performance Requirements

EP4.1 Visibility in an emergency

The intent of [EP4.1](#) is to provide occupants with satisfactory visibility in an emergency. Sufficient visual conditions must be provided in a building to aid safe evacuation during an emergency. Accordingly, visibility must be sufficient to:

- minimise the risk of panic;
- make the safe route to an emergency exit visible;
- identify obstacles within the path; and
- otherwise assist in the orderly and safe evacuation of the building.

EP4.1 Limitations

[EP4.1](#) does not apply within sole-occupancy units of Class 2, 3 or 9c buildings or within the Class 4 part of a building.

Operation when artificial lighting fails

A system to provide visibility in an emergency within a building only needs to operate on the failure of the normal artificial lighting system (see [EF4.1\(a\)](#)).

“To the degree necessary”

[EP4.1](#) uses the expression “to the degree necessary”. The BCA recognises that not all buildings need the same level of visibility in an emergency.

Any decision made in this context can extend to not requiring an item to be installed or a particular level of performance to be achieved, if that is the appropriate action to be taken.

Criteria for visibility in an emergency

As set out in [EP4.1](#), a system to provide visibility in an emergency must be installed when necessary, and be appropriate to a number of factors, including:

- the use of the building will affect the fire load in the building;
- the size of the building’s floor area which is a measure of the size of any potential fire, and the area through which occupants must travel to reach safety; and
- the distance of travel to an exit which is a measure of the distance occupants must travel to reach safety (and therefore the time necessary to reach safety).

“Appropriate to”

The system to provide visibility in an emergency must be “appropriate to” the matters listed in [EP4.1](#), which relate to the amount of visibility in a particular building, and which is necessary to enable evacuation in an emergency.

Examples

The following are two examples of what may or may not be “appropriate” in this case. They should not be regarded as absolute.

Commercial poultry building

A commercial poultry building:

- has a high level of natural light;
- is occupied by only a few workers, likely to know the shed well;
- is rarely occupied by humans at night;
- is without a substantial floor space accessible by humans; and
- has short and direct routes to the exit doors.

In such a case, it may be reasonable for no system to provide visibility in an emergency in this particular building.

Note that for the example above, it is assumed that the building in question has not met the criteria to be considered a farm building or farm shed in the Deemed-to-Satisfy Provisions.

Cinema

A cinema, however:

- has no natural light; and
- is occupied regularly by large numbers of people who do not know the building or its evacuation plan well.

Services and equipment

In such a case, even having no regard to the floor area or the distance of travel to an exit, it is probable that the building will require a system to provide visibility in an emergency such as an artificial illumination system and/or a way guidance system.

Deemed-to-Satisfy Provisions

E4.2 provides a number of examples where emergency lighting systems must be installed if the proposal being considered involves a solution which utilises the Deemed-to-Satisfy Provisions.

Performance Solutions

If a Performance Solution is being used, it may be appropriate to assess it using E4.2 for guidance purposes.

Stand-by lighting and safety lighting

If the system to provide visibility in an emergency is an emergency lighting system, it should not be confused with the following:

Stand-by lighting

This is a term used to describe a lighting system providing a relatively high lighting level to allow normal activities to continue in case of a failure of the normal lighting system.

Example

A generator may be used to provide a “working” level of light in case of a power failure. Such a level of light may be directed to different locations than the emergency routes required to achieve a safe evacuation.

Safety lighting

This is a term used to describe a lighting system provided for the safety of occupants working near hazardous equipment or processes.

Example

The safe operation of specific equipment may require a level of lighting beyond that normally required for work conditions, and significantly beyond that required for safe evacuation.

EP4.2 Identification of exits

The intent of E4.2 is to provide occupants with clear and concise information on what route to take to evacuate a building in an emergency. This may require the installation of emergency signage or other suitable means to identify egress routes and exits and assist in orderly evacuation.

This information must be easily obtainable, despite the reduced lighting conditions, even though emergency lighting systems have been provided.

EP4.2 Limitations

EP4.2 does not apply within sole-occupancy units of Class 2 or 3 buildings or within the Class 4 part of a building.

“To the degree necessary”

EP4.2 uses the expression “to the degree necessary”. The BCA recognises that not all buildings need signs or markers to facilitate evacuation.

Any decision made in this context can extend to not requiring an item to be installed or a particular level of performance to be achieved, if that is the appropriate action to be taken.

Criteria for identification of exits

A building proposal must make sure that the means used to identify egress routes and exits are sufficient to enable occupants:

- to locate the exits;
- to find their way to the exits;
- to clearly see any signs or other markers; and
- to be able to continue to see any signs or markers during their evacuation, in case of a failure of the normal lighting system.

Examples

The following are two examples of what may or may not be suitable exit identification. They should not be regarded as absolute.

Services and equipment

Commercial poultry building

A commercial poultry building:

- has a high level of natural light;
- is occupied by only a few workers, who are likely to know the shed well;
- is rarely, if ever, occupied by people at night; and
- has direct routes to the exit doors.

In such a case, occupants will be able to easily find the way to the exits. Accordingly, exit signs would not be necessary.

Note that for the example above, it is assumed that the building in question has not met the criteria to be considered a farm building or farm shed in the Deemed-to-Satisfy Provisions.

Cinema

A cinema, however:

- has no natural light; and
- is occupied regularly by large numbers of people who do not know the building or its evacuation routes.

In such a case, clear and illuminated signage would be required, located in common view points to encourage evacuees to continue travelling in a specific direction.

Deemed-to-Satisfy Provisions

If a builder is undertaking a solution using the Deemed-to-Satisfy Provisions, there are a number of relevant provisions regarding:

- the installation of exit signs; and
- the size, colour and wording of signs.

Performance Solutions

If a Performance Solution is being used, it may be appropriate to assess it using the [Part E](#) Deemed-to-Satisfy Provisions for guidance purposes.

EP4.3 Emergency warning and intercom systems

Early warning and communication

The intent of [EP4.3](#) is to maximise the opportunities for occupants to evacuate. This may include giving them as early a warning as possible and providing means of communicating both the need for evacuation and the process of evacuation.

Evacuation management systems

Emergency evacuation requires that the evacuation maximises the opportunity for occupants to reach a place of safety. Since the BCA relates to the construction of a building it can only require the installation of a system. It cannot require:

- training, so that the evacuation process is undertaken automatically;
- allocation of staff to assist with evacuation, particularly if the building is likely to contain occupants who have been unable to benefit from prior training; or
- a detailed evacuation plan.

“To the degree necessary”

[EP4.3](#) uses the expression “to the degree necessary”. The BCA recognises that different buildings require differing types and degrees of emergency warning and intercom systems for occupants.

Any decision made in this context can extend to not requiring an item to be installed or a particular level of performance to be achieved, if that is the appropriate action to be taken.

Criteria for emergency warning and intercom system

As set out in [EP4.3](#), to warn occupants and assist with an evacuation, an emergency warning and intercom system must be appropriate to a number of factors, including:

- the floor area of the building which is a measure of the size of any potential fire, the area to be covered by a warning sound or signal, and the difficulty of intercommunication;
- the function of the building will affect the fire load in the building, and the difficulty such a load may cause in evacuating occupants; and
- the height of the building which is a measure of the difficulty of evacuation, search and rescue, and communication.

Services and equipment

“Appropriate to”

The emergency warning and intercom system must be “appropriate to” the matters listed in [EP4.3](#), which principally relate to the type of system which is necessary to enable evacuation in an emergency.

The BCA recognises that different emergency warning and communication needs may exist, depending on the size of the building, its function, use and height.

Examples

The following reveal what may or may not be “appropriate”. They should not be regarded as absolute.

Commercial poultry building

A commercial poultry building:

- has a comparatively small floor area accessible by occupants;
- is occupied by only a few workers, who are likely to know the shed well; and
- has good sight lines around the building.

In such a case, the ability of occupants to notice an emergency starting, particularly a fire, and their capacity to easily notify other occupants and exit quickly may mean that there is little or no need for emergency warning and intercom systems.

Note that for the example above, it is assumed that the building in question has not met the criteria to be considered a farm building or farm shed in the Deemed-to-Satisfy Provisions.

Cinema

In a cinema, however, there is a large number of people who do not know the building or its evacuation routes.

In such a case, the building’s occupants may be:

- unlikely to notice the commencement of an emergency, which could involve electrical or equipment failure in parts of the building beyond the auditorium; and
- unlikely to automatically know when or how to exit the building.

Accordingly, there may be a need for specialised emergency warning and intercom systems.

Deemed-to-Satisfy Provisions

If the proposal being considered involves a solution which utilises the Deemed-to-Satisfy Provisions, the Deemed-to-Satisfy Provisions provide a number of situations where emergency warning and intercom systems must be installed.

Performance Solutions

If a Performance Solution is being used, it may be appropriate to assess it using the [Part E4](#) Deemed-to-Satisfy Provisions for guidance purposes.

Verification Methods

EV4.1 Emergency Lighting

[EV4.1](#) does not verify full compliance with [EP4.1](#). [EV4.1](#) is a means of verifying if a proposed emergency lighting system achieves the level of visibility for safe evacuation and the instantaneous activation required by [EP4.1](#) in an emergency. The appropriate authority will still need to be satisfied that the proposed emergency lighting system is appropriate to:

- the function or use of the building;
- the floor area of the building; and
- the distance of travel to an exit.

It is not compulsory for a designer to use [EV4.1](#). The designer has the choice of using:

- [EV4.1](#) to verify that the proposal achieves [EP4.1](#);
- the Deemed-to-Satisfy Provisions of [E4.2](#) to [E4.4](#); or
- another means of verifying that [EP4.1](#) will be achieved.

If [EV4.1](#) is used to verify compliance, a designer may choose the method used to determine the:

- calculated horizontal illuminance at [EV4.1\(a\)](#);
- illumination and delay at switch-on at [EV4.1\(b\)](#) and [\(c\)](#); and
- operation time at [EV4.1\(d\)](#).

Part E4 Visibility in an emergency, exit signs and warning systems

Deemed-to-Satisfy Provisions

E4.0 Deemed-to-Satisfy Provisions

Intent

To clarify that compliance with EP4.1 to EP4.3 will be achieved by compliance with E4.1 to E4.9 in the case of all buildings, Part G3 in the case of buildings with an atrium, Part G4 in the case of buildings in alpine areas, Part G6 in the case of occupiable outdoor areas, Part H1 in the case of theatres, stages and public halls and Part H3 for farm buildings and farm sheds.

Where a solution is proposed to comply with the Deemed-to-Satisfy Provisions, E4.0 clarifies that, for most buildings, if compliance can be demonstrated with E4.1 to E4.9, then compliance has been achieved with EP4.1 to EP4.3. The exceptions to this general rule are as follows:

- If the building contains an occupiable outdoor area, it must comply with Part G6 in addition to E4.1 to E4.9.
- Farm buildings and farm sheds must comply with Part H3 in addition to E4.1 to E4.9.

Where a Performance Solution is proposed, the relevant Performance Requirements must be determined in accordance with A2.2(3) and A2.4(3) as applicable. (See commentary on Part A2).

E4.1 * * * * *

In accordance with the decision not to change the numbering of the BCA from that of the previous edition, the space previously occupied by this provision has been left blank. The previous E4.1 provisions are now located in the BCA Performance Requirements.

E4.2 Emergency lighting requirements

Intent

To minimise the risk of death or injury to occupants during an emergency because of an inability to see their way along an exit path of travel.

Reasons for emergency lighting

See the comment on EP4.1.

Locations for emergency lighting

E4.2 sets out the locations in buildings, and in some cases the classes of building, in which emergency lighting must be installed.

Each sub-provision of E4.2 must be considered separately. It is possible that more than one may apply to any single building. Where any sub-provision requires emergency lighting, such lighting must be provided, even though another sub-provision may appear to provide an exemption.

Example

Consider a single storey building comprised of three open plan Class 6 sole-occupancy units of 150 m² each, where each sole-occupancy unit has one exit direct to open space:

- E4.2(e) specifies that emergency lighting is not required in each sole-occupancy unit (note that the 300 m² minimum in E4.2(e)(i) applies to an individual sole-occupancy unit); but
- E4.2(f) specifies that every room or space to which there is public access (in this case, each entire sole-occupancy unit—note that the 300 m² minimum in E4.2(f)(i) applies to the entire storey) must have emergency lighting.

In this case, as E4.2(f) requires emergency lighting, such lighting must be provided despite the fact that the sole-occupancy units do not require such lighting under E4.2(e).

Extent of emergency lighting

All fire-isolated exits—E4.2(a)

Services and equipment

Emergency lighting is required to be installed in all fire-isolated exits, because it is unusual for them to be provided with sufficient amounts of natural lighting for safe evacuation.

Storeys over 300 m² in Class 5–9 buildings—E4.2(b)

Emergency lighting is required in every storey with a floor area over 300 m² in a Class 5–9 building, as follows:

- Every passageway, corridor, hallway, or the like forming part of a path of travel to an exit, because these areas are unlikely to be provided with sufficient amounts of natural lighting for safe evacuation.
- Any room larger than 100 m² which does not open to a corridor or other space containing emergency lighting, or a road or open space.
- Any room larger than 300 m². Note that this size of room is relatively large, and E4.2(b)(iii) applies irrespective of whether or not the room opens to a corridor or other space containing emergency lighting or a road or open space.

Class 2, Class 3 and Class 4—E4.2(c)

Emergency lighting is required in any passageway, corridor, hallway, or the like in Class 2 and Class 3 buildings and Class 4 parts, if the distance of travel from the door leading from a sole-occupancy unit is greater than six metres to:

- a fire-isolated exit;
- an external stairway used in lieu of a fire-isolated stairway;
- an external balcony leading to a fire-isolated exit; or
- a road or open space.

This provision reflects the likelihood that such buildings will be occupied at night, when the occupants are likely to be asleep.

Non-fire-isolated stairways—E4.2(d)

Emergency lighting is required to be installed in all required non-fire-isolated stairways (note that E4.2(d) applies even if the other provisions of E4.2 do not require the installation of emergency lighting).

Sole-occupancy unit in Class 5, Class 6 or Class 9—E4.2(e)

Emergency lighting is required to be installed in a sole-occupancy unit of a Class 5, Class 6 or Class 9 building if:

- the area of the unit is larger than 300 m²; and
- the exit from the unit does not open to the specified areas or spaces which are likely to have adequate natural lighting.

Publicly accessible room in Class 6 or Class 9b—E4.2(f)

Emergency lighting is required to be installed in every publicly accessible room or space in a Class 6 or Class 9b building if:

- the area of the storey is relatively large (i.e. greater than 300 m²);
- any point on the floor is more than 20 metres from the specified doorways (which is a distance compatible with Section D requirements);
- egress requires a vertical rise of 1.5 metres;
- egress requires any vertical rise, if insufficient light is not admitted from outside the building; or
- the storey provides a path of travel from another storey included in E4.2(f)(i)–(iii). In this case, once a person enters an area with emergency lighting, then that lighting must be maintained throughout the remainder of the egress path.

This provision reflects the likelihood that such buildings are used by large numbers of the public who do not have any knowledge of the building or its exits.

Class 9a—E4.2(g)

Emergency lighting is required to be installed in the specified areas in Class 9a buildings, because such buildings are used by patients who may require assistance to evacuate.

Class 9c—E4.2(h)

Emergency lighting is required to be installed throughout Class 9c buildings excluding within the sole-occupancy units. The requirement is generally aligned with the principles for emergency lighting in Class 9a buildings as described above.

Required fire control centres—E4.2(h)

Emergency lighting is required to be installed in required fire control centres, because they are designed for use by the fire brigade during an emergency, such as a fire.

Services and equipment

E4.3 Measurement of distance**Intent**

To clarify how distance must be measured for the purposes of emergency lighting required under [E4.2](#).

Reasons for emergency lighting

See the comment on [EP4.1](#).

To which distances does [E4.3](#) refer?

While not specifically stated, the intention is that the distances referred to in [E4.3](#) to be those calculated in accordance with [E4.2\(c\)](#) and (f)(ii).

Most direct route

The [E4.2\(c\)](#) and (f)(ii) distances are required to be measured the same way as those specified in [Section D](#). See [D1.15](#).

E4.4 Design and operation of emergency lighting**Intent**

To specify how an emergency lighting system must operate, to minimise the risk of death or injury to occupants during an emergency because of an inability to see their way along an exit path of travel.

Reasons for emergency lighting

See the comment on [EP4.1](#).

Emergency lighting system and safe evacuation

An emergency lighting system must provide the visual conditions necessary for safe evacuation during an emergency such as a fire. It must be installed in accordance with AS/NZS 2293.1.

It should be noted that this is an emergency lighting system which is only required to operate during an emergency. [F4.4\(a\)\(i\)](#) requires artificial lighting to be provided within required stairways, passageways and ramps, but does not require such lighting to be illuminated at all times.

E4.5 Exit signs**Intent**

To minimise the risk of death or injury to occupants during an emergency because of an inability to find an exit.

Reasons for exit signs

See the comment on [EP4.1](#).

Locations of exit signs

[E4.5](#) sets out the locations in a building requiring the installation of exit signs. Signs must be clearly visible to occupants approaching the exit. They need to be located on, above or adjacent to the specified exits and doors.

Some exemptions to [E4.5](#)

[E4.7](#) provides some exemptions to [E4.5](#). See [E4.7](#).

E4.6 Direction signs**Intent**

To minimise the risk of death or injury to occupants during an emergency because of an inability to find their way along an exit path of travel.

Reasons for direction signs

Exits may not be visible from all locations within a building. In such cases, exit signs with directional indicators (such as arrows) are required to clearly indicate the direction of travel to required exits.

Services and equipment

E4.7 Class 2 and 3 buildings and Class 4 parts: Exemptions

Intent

To specify some circumstances where risk levels do not warrant compliance with [E4.5](#).

Class 2 buildings—[E4.7\(a\)](#)

The BCA considers that the risks to occupants of units within a Class 2 building are less than those to occupants of Class 3 buildings and Class 4 parts. This is because occupants of Class 2 buildings are assumed to be more familiar with:

- the layout of their unit;
- the layout of the building within which the unit is located; and
- Class 4 parts attached to parts of a building with different (and usually greater) fire loads.

Consequently, [E4.7\(a\)](#) grants an exemption for Class 2 buildings from the need to comply with [E4.5](#), on the condition that the buildings comply with certain specific provisions.

With regard to [E4.7\(a\)\(i\)](#), while the size and wording of the exit sign are specified, the structure, method of attachment, or colour and the like are not specified. However, the colour of the word must contrast with that of the background. The building proponent can make this decision as long as the appropriate authority is satisfied.

With regard to [E4.7\(a\)\(ii\)](#), if a suitable alternative means of notification can be found to the requirements of [E4.7\(a\)\(i\)](#), it may be used. The decision is made by the building proponent, who must satisfy the appropriate authority.

Entrances to Class 2, Class 3 or Class 4—[E4.7\(b\)](#)

The BCA assumes that the occupants of units in Class 2 or Class 3 buildings, or in Class 4 parts of a building are familiar with the layouts of their units to allow [E4.7\(b\)](#) to grant an exemption so that exit signs are not required above what is described as the “entrance door”, being either:

- the main door from the unit into the remainder of the building; or
- the door leading directly outside from the unit.

E4.8 Design and operation of exit signs

Intent

To specify how exit signs must be designed and operate, to minimise the risk of death or injury to occupants during an emergency because of an inability to find an exit.

Criteria for exit signs

[E4.8](#) sets out the provisions for required exit signs, which must meet the following criteria:

- they must be visible at all times when the building is occupied by a person who has a legal right of entry. Exit signs have a function during normal periods to make occupants aware of the location of exits; and
- the system must comply with—
 - AS/NZS 2293.1; or
 - for photoluminescent exit signs, [Specification E4.8](#), which varies some of the requirements of AS/NZS 2293.1.

E4.9 Emergency warning and intercom systems

Intent

To minimise the risk of death or injury to occupants through lack of knowledge that an emergency exists or an evacuation is required.

Reasons for emergency warning systems

See the comment on [EP4.3](#).

Types of buildings requiring such a system

[E4.9](#) sets out the types of buildings requiring the installation of an emergency warning and intercom system.

AS 1670.4

Building proposals using the Deemed-to-Satisfy Provisions to achieve the Performance Requirements must comply with

Services and equipment

AS 1670.4, where applicable.

Building with an effective height of more than 25 metres—E4.9(a)

In a building with an effective height of more than 25 metres, if a fire starts on one floor, there is a considerable risk that occupants of the other floors might not be aware it has started. Co-ordination of the evacuation process is important. This reduces confusion and congestion in the stairways and accordingly the time taken for the evacuation.

The people most at risk

In a building fire, the highest degree of risk is attached to such people as the very young, people with certain types of disability (such as a mobility disability), the elderly, and those asleep.

The BCA cannot address all possible permutations of people who are likely to be in any particular building. Nonetheless, it does attempt to address the risks that are most likely to be attached to the people most likely to be in particular types of building.

Installation for larger buildings

In most cases, the need to install an emergency warning and intercom system only applies to larger buildings. The reason for this requirement is the heightened risk that occupants may not be aware of a fire in another part of the building.

Residential care and Class 9a buildings

In Class 3 residential care buildings and in Class 9a buildings, many of the occupants or patients are unable to evacuate without assistance. There is also an enhanced risk in many of these buildings that residents or patients will be traumatised by loud or insistent alarms. To minimise this risk, the sound system and intercom system:

- must be arranged to warn occupants, including staff, residents and patients; and
- may be adjusted to take account of any special issues regarding residents or patients.

Specification E4.8

Photoluminescent exit signs

Deemed-to-Satisfy Provisions

1 Scope

Intent

To clarify that [Specification E4.8](#) provides the design and installation details for photoluminescent exit signs.

What is Photoluminescence?

Photoluminescence is the ability of a material to absorb light and UV rays, and re-emit visible light for a period after the source light has been removed. Another term used instead of photoluminescence is 'long afterglow phosphorescence', because the only difference between a phosphor, as used on the surface of many electrical lamps and a photoluminescent material, is the time delay between receiving incident radiation and the emission of the useful light. For ordinary phosphors the time delay is normally measured in fractions of a second, whereas with photoluminescent materials the delay ranges from fractions of a second through to hours and even days. It is this feature which makes the material glow for a longer time after normal lighting is removed. The brightness and the time of the useful glow depend on:

- the properties of the photoluminescent material itself;
- the type of light that is being used to 'charge' the photoluminescent material;
- the brightness of that charging light; and
- the charging time.

2 Application

Intent

To clarify the application of the Specification and relationship with AS/NZS 2293.1.

AS/NZS 2293.1

Requirements for emergency exit signs are contained in AS/NZS 2293.1. When this standard was drafted, requirements for photoluminescent exit signs were not included.

Therefore, the requirements for photoluminescent exit signs in [Specification E4.8](#) apply specific parts of the standard with variations.

Specific considerations for photoluminescent exit signs contained within [Specification E4.8](#) include:

- illumination;
- smoke control systems;
- sign colour;
- size of pictorial elements;
- viewing distances; and
- borders.

For the purposes of applying the Standard for photoluminescent exit signs, Section 5 and Appendix D must be used.

3 Illumination

Intent

To specify the minimum illumination, luminance and duration for the performance of a photoluminescent exit sign.

The illumination component of [Specification E4.8](#) is an important factor for the effective operation of photoluminescent exit signs.

[Clause 3\(a\)](#) requires the sign to be maintained in a continuously charged state by a minimum illumination of 100 lux at the face of the sign by a dedicated light source with a colour temperature not less than 4000 kelvins. This ensures the conspicuity of the sign and that, in the event of power failure, the photoluminescent material of the sign is charged

Services and equipment

to the requirements of [Clause 3\(b\)](#).

[Clause 3\(b\)](#) requires the sign to have a minimum luminance of 30 millicandelas per square metre (mcd/m²) for a minimum duration of 90 minutes in the event of a power failure. This reflects current international practice.

[Clause 3\(c\)](#) references ASTM E2073-10 as a testing method to verify the photoluminescent exit sign complies with [Clause 3\(b\)](#). The testing method under ASTM E2073-10 requires a 60 minute charge with an input of 10.8 lux at the face of the sign. However, for the purpose of this Specification, this test is varied to require an input of 54 lux at the face of the sign for 60 minutes.

4 Pictorial elements

Intent

To ensure the critical elements of the photoluminescent exit sign are visible.

[Clause 4\(a\)](#) varies the colours of a standard exit sign comprising a green background with white pictorial elements to allow for application to a photoluminescent exit sign. For a photoluminescent exit sign however, due to the nature of how it functions, it is not practical to include the white component of the sign. Therefore where white is used on a photoluminescent exit sign, the white colour must be replaced by a photoluminescent material.

In addition to the illumination requirements of [Clause 3](#) to ensure a photoluminescent exit sign is visible, [Clause 4\(b\)](#) requires pictorial elements be 1.3 times the dimensional sizes specified in AS/NZS 2293.1. This is consistent with international standards.

5 Viewing distance

Intent

To ensure a photoluminescent exit sign is visible.

To ensure a photoluminescent exit sign is visible the maximum viewing distance of a photoluminescent exit sign is restricted to 24 m. Again, this is consistent with international standards.

6 Smoke control systems

Intent

To allow photoluminescent exit signs to be installed in all areas, not just where an area is provided with appropriate means for automatically exhausting or excluding smoke.

Within AS/NZS 2293.1, clause 5.3 states that externally illuminated exit signs shall be used only in areas that are provided with appropriate means for automatically exhausting or excluding smoke. However, photoluminescent exit signs are illuminated externally and internally by virtue of the material properties and an exclusion from compliance with clause 5.3 is provided.

Health and amenity

- Part F1** **Damp and weatherproofing**
- Part F2** **Sanitary and other facilities**
- Part F3** **Room heights**
- Part F4** **Light and ventilation**
- Part F5** **Sound transmission and insulation**
- Part F6** **Condensation management**

Section F Health and amenity

Part F1 Damp and weatherproofing

Objective

FO1

Functional Statements

FF1.1

FF1.2

FF1.3

Performance Requirements

FP1.1 Managing rainwater impact on adjoining properties

FP1.2 Preventing rainwater from entering buildings

FP1.3 Rainwater drainage systems

FP1.4 Weatherproofing

FP1.5 Rising damp

FP1.6 Wet area overflows

FP1.7 Wet areas

Verification Methods

FV1.1 Weatherproofing

FV1.2 Overflow protection

Deemed-to-Satisfy Provisions

F1.0 Deemed-to-Satisfy Provisions

F1.1 Stormwater drainage

F1.2 * * * * *

F1.3 * * * * *

F1.4 External above ground membranes

F1.5 Roof coverings

F1.6 Sarking

F1.7 Waterproofing of wet areas in buildings

F1.8 * * * * *

F1.9 Damp-proofing

F1.10 Damp-proofing of floors on the ground

F1.11 Provision of floor wastes

F1.12 Subfloor ventilation

F1.13 Glazed assemblies

Part F2 Sanitary and other facilities

Objective

FO2

Functional Statements

FF2.1

FF2.2

FF2.3

FF2.4

Performance Requirements

FP2.1 Personal hygiene facilities

FP2.2 Laundry facilities

FP2.3 Kitchen facilities

FP2.4 Disposal of contaminated water from containers

FP2.5 Construction of sanitary compartments to allow removal of unconscious people

FP2.6 Microbial control for water systems

Verification Methods

FV2.1 Sanitary facilities

Deemed-to-Satisfy Provisions

- F2.0 Deemed-to-Satisfy Provisions
- F2.1 Facilities in residential buildings
- F2.2 Calculation of number of occupants and facilities
- F2.3 Facilities in Class 3 to 9 buildings
- F2.4 Accessible sanitary facilities
- F2.5 Construction of sanitary compartments
- F2.6 Interpretation: Urinals and washbasins
- F2.7 Microbial (legionella) control
- F2.8 Waste management
- F2.9 Accessible adult change facilities

Specification F2.9 Accessible adult change facilities**Part F3 Room heights****Objective**

FO3

Functional Statements

FF3.1

Performance Requirements

FP3.1 Room or space heights

FV3.1 Room or space height

Deemed-to-Satisfy Provisions

F3.0 Deemed-to-Satisfy Provisions

F3.1 Height of rooms and other spaces

Part F4 Light and ventilation**Objective**

FO4

Functional Statements

FF4.1

FF4.2

FF4.3

Performance Requirements

FP4.1 Natural lighting

FP4.2 Artificial lighting

FP4.3 Outdoor air supply

FP4.4 Mechanical ventilation to control odours and contaminants

FP4.5 Disposal of contaminated air

Verification Methods

FV4.1 Verification of suitable indoor air quality

FV4.2 Verification of suitable indoor air quality for carpark

FV4.3 Verification of suitable provision of natural light

Deemed-to-Satisfy Provisions

F4.0 Deemed-to-Satisfy Provisions

F4.1 Provision of natural light

F4.2 Methods and extent of natural light

F4.3 Natural light borrowed from adjoining room

F4.4 Artificial lighting

F4.5 Ventilation of rooms

F4.6 Natural ventilation

F4.7 Ventilation borrowed from adjoining room

F4.8 Restriction on location of sanitary compartments

F4.9 Airlocks

F4.10 * * * * *

- F4.11 Carparks
- F4.12 Kitchen local exhaust ventilation

Part F5 Sound transmission and insulation

Objective

FO5

Functional Statements

FF5.1

Performance Requirements

- FP5.1 Sound transmission through floors
- FP5.2 Sound transmission through walls
- FP5.3 Sound transmission through floor and wall penetrations and door assemblies
- FP5.4 Sound transmission through floors in residential care buildings
- FP5.5 Sound transmission through walls in residential care buildings
- FP5.6 Sound transmission through floor and wall penetrations in residential care buildings

Verification Methods

- FV5.1 Sound transmission through floors [FP5.1 and FP5.3]
- FV5.2 Sound transmission through walls [FP5.2(a) and FP5.3]
- FV5.3 Sound transmission through floors [FP5.4 and FP5.6]
- FV5.4 Sound transmission through walls [FP5.5(a) and FP5.6]

Deemed-to-Satisfy Provisions

- F5.0 Deemed-to-Satisfy Provisions
- F5.1 Application of Part
- F5.2 Determination of airborne sound insulation ratings
- F5.3 Determination of impact sound insulation ratings
- F5.4 Sound insulation rating of floors
- F5.5 Sound insulation rating of walls
- F5.6 Services
- F5.7 Isolation of pumps

Specification F5.2 Sound insulation for building elements

Deemed-to-Satisfy Provisions

Specification F5.5 Impact sound—Test of equivalence

Deemed-to-Satisfy Provisions

Part F6 Condensation management

Objectives

FO6 Condensation

Functional Statements

FF6.1 Condensation

Performance Requirements

- FP6.1 Condensation and water vapour management

Verification Methods

FV6 Condensation management

Deemed-to-Satisfy Provisions

- F6.0 Deemed-to-Satisfy Provisions
- F6.1 Application of Part
- F6.2 Installation of pliable building membrane
- F6.3 Discharge of exhaust systems
- F6.4 Ventilation of roof spaces

Part F1 Damp and weatherproofing

Objective

FO1

The Objective of this Part is to—

- (a) safeguard occupants from illness or injury and protect the building from damage caused by—
- (i) surface water; and
 - (ii) external moisture entering a building; and
 - (iii) the accumulation of internal moisture in a building; and
- (b) protect other property from damage caused by redirected surface water.

Safeguard occupants and protect the building—FO1(a)

FO1(a) aims to minimise the risk of water leaking into or accumulating within a building and causing musty, damp and unhealthy conditions or damaging building elements by corrosion.

Examples

- Damp conditions in houses can cause serious diseases. What appear to be less serious illnesses, such as colds, can have serious consequences, particularly for children and the elderly.
- Rotten floorboards can collapse, causing injury.
- Electrical connections can corrode, causing failure of safety devices, or increasing the risk of electrocution.
- Penetration of moisture into building elements can cause degradation to a building long before the damage is detected.

Protect other property from damage—FO1(b)

FO1(b) aims to minimise the risk of other property being damaged by surface water redirected from a building or any associated sitework.

Example

Construction on an allotment must not cause re-directed water damage to “other property”, including:

- any building on the same allotment;
- any building on an adjoining allotment;
- any adjoining allotment (whether there is a building on it or not); and
- any road.

Functional Statements

FF1.1

A building including any associated sitework is to be constructed in a way that protects people and other property from the adverse effects of redirected surface water.

Protection from re-directed surface water

People and other property are to be protected from any problems caused by surface water re-directed by a building and any sitework involved in its construction. Remedial works must be undertaken to dispose of any surface water which, because of any variation or addition to its flow caused by any building or sitework, causes harm to people or other property.

FF1.2

A building is to be constructed to provide resistance to moisture penetrating from the outside including rising from the ground.

Resistance to rain, surface water and ground water

Health and amenity

A building must resist:

- rainwater, coming through the roof or walls, due to poor waterproofing or flashing;
- surface water, coming through openings which are too low; and
- ground water, which could rise up through porous floors or walls.

Ground water could enter a building if there are inadequate damp-proof courses or vapour barriers installed, or if other ways of resisting the rising damp have not been provided.

FF1.3

A building is to be constructed to avoid the likelihood of—

- the creation of unhealthy or dangerous conditions; and
- damage to building elements,

caused by dampness or water overflow from bathrooms, laundries and the like.

Overflow from bathrooms and laundries

The development of unhealthy conditions or damage caused by dampness or overflow from bathrooms, laundries and the like, must be prevented. Such problems may arise from showers and bathrooms being incorrectly sealed, allowing water to leak into other parts of the building.

Performance Requirements

FP1.1 Managing rainwater impact on adjoining properties

Surface water from a 1 in 20 year storm

Surface water from a 1 in 20 year storm collected or concentrated by a building or sitework must be disposed of without damage to other property.

Construction should not cause stormwater problems on other properties, worse than those which existed previously.

Example

As a general rule, undeveloped land tends to absorb rainwater, usually resulting in comparatively slow run-off.

However, a building's hard surfaces, such as roofs and pavements, cause comparatively quick run-off. Consequently, the design of the surfacewater disposal system must make provision for run-off stormwater from hard surfaces collected or concentrated by a building or sitework.

Why 1 in 20 year storms?

The storm intensity has been limited to a 1 in 20 year storm. This is considered an appropriate limit, fair on the person responsible for the building and siteworks and the person responsible for properties affected by re-directed surface water.

FP1.2 Preventing rainwater from entering buildings

Surface water from a 1 in 100 year storm

Building and siteworks must be arranged so that surface water from a 1 in 100 year storm does not enter a building.

Why 1 in 100 year storms?

A 1 in 20 year storm has a less intense flow of water than a 1 in 100 year storm, which is what the subject building must be protected from.

It is considered more important to prevent water entering a building than it is to prevent water entering a neighbouring allotment or property.

Limitations

The limitations contain several exemptions to [FP1.2](#). These are based on the belief that the use and safety levels of the exempted buildings will not be significantly diminished by surface water entering them.

Limitation (a) regarding Class 7 and Class 8 buildings refers only to such buildings which, in a particular case, do not exhibit any need for compliance with [FP1.2](#). Such buildings must be considered on a case-by-case basis. However, it is the responsibility of a building proponent to satisfy the appropriate authority that the exemption should apply.

FP1.3 Rainwater drainage systems

Outfall, water entrance and water damage

Under [FP1.3\(a\)](#) a drainage system for the disposal of surface water from a 1 in 20 year storm must:

- have an appropriate outfall; and
- avoid damage to the building.

An outfall includes a kerb and channel, a soakage system, and a natural watercourse, with the decision as to what is appropriate being made by the appropriate authority. Damage to the building could be caused by a building's subsidence.

Under [FP1.3\(b\)](#), a drainage system for the disposal of surface water must avoid surface water from a 1 in 100 year storm from entering a building. This provision is intended to prevent surface water causing internal damage to a building, or causing injury or illness to occupants.

The [FP1.3\(b\)](#) prohibition on surface water entering the building:

- does not prohibit a drainage system that passes surface water through a building (probably by way of pipes) without causing damage; and
- clearly does not prohibit water entering a building when it is required for various purposes.

FP1.4 Weatherproofing

Roofs and walls to prevent water penetration

Roofs and walls (including windows, doors and other openings in the walls) must prevent water penetration which could cause dangerous conditions, loss of amenity or dampness and deterioration of building elements.

Limitations

The limitations contain several exemptions to [FP1.4](#). These are based on the belief that the use and safety levels of the exempted buildings will not be significantly diminished by water entering them.

Limitation (a), regarding Class 7 and Class 8 buildings, refers only to such buildings which, in a particular case, do not exhibit any need for compliance with [FP1.4](#). Such buildings must be considered on a case-by-case basis. However, it is the responsibility of a building proponent to satisfy the appropriate authority that the exemption should apply.

FP1.5 Rising damp

Moisture from the ground

Building elements must be protected from deterioration and occupants must be protected from unhealthy or dangerous conditions or a loss of amenity caused by moisture from the ground (causing such problems as rot, rising damp, rust, and so on). In essence, this requires that the materials and components which make up building elements must either be fit for this purpose or made fit by protection.

Examples

The following may be acceptable to achieve compliance with [FP1.5](#). They should not be regarded as absolute.

- damp-proof course in masonry walls above finished ground level;
- vapour barrier under a concrete slab;
- adequate subfloor ventilation;
- painted or other similar protective coatings on steel and timber on or near ground level;
- appropriate concrete cover on steel reinforcing;
- galvanised coatings on steel; and
- specific concrete mixes to achieve required protection levels.

FP1.6 Wet area overflows

Water overflows from bathrooms and laundries

Water overflows from bathrooms, laundries and the like must be prevented from penetrating downwards—i.e. to a storey below—to either another sole-occupancy unit used for sleeping accommodation or a public space. Such overflows are potentially unhealthy and structurally damaging, and can be disruptive for neighbours.

FP1.7 Wet areas

Water — fittings, linings and concealed spaces

The structure of a building and the amenity of its occupants must be protected by preventing water from penetrating behind fittings and linings and into concealed spaces of toilets, bathrooms, laundries and the like.

Verification Methods

FV1.1 Weatherproofing

FV1.1 is a means to verify whether or not a proposed external wall achieves the requirements of **FP1.4**, i.e. whether the wall prevents the penetration of water that could cause:

- unhealthy or dangerous conditions or loss of amenity for occupants; and
- undue dampness or deterioration of building elements.

FV1.1 is not a mandatory component of the NCC, however it is one form of assessment method which can be used to demonstrate compliance with the Performance Requirements.

Other assessment methods in the NCC include:

- evidence to support that the use of a material, form of construction or design meets the Performance Requirement or a Deemed-to-Satisfy Provision;
- comparison with a Deemed-to-Satisfy Provision where applicable; or
- expert judgement, which means the judgement of an expert who has the qualifications and experience to determine whether a solution complies with the Performance Requirements.

The Verification Method must be applied in the following order:

- confirm the limitations of **FV1.1(a)(i)** to **(iii)** are met;
- develop a test specimen including representative samples of openings and the like (**FV1.1(b)**);
- test the specimen in accordance with the relevant test procedure (**FV1.1(c)**);
- assess the specimen against the compliance criteria (**FV1.1(d)**); and
- record the test results (**FV1.1(e)**).

This process is shown in **Figure FV1.1(1)**.

Figure FV1.1(1)

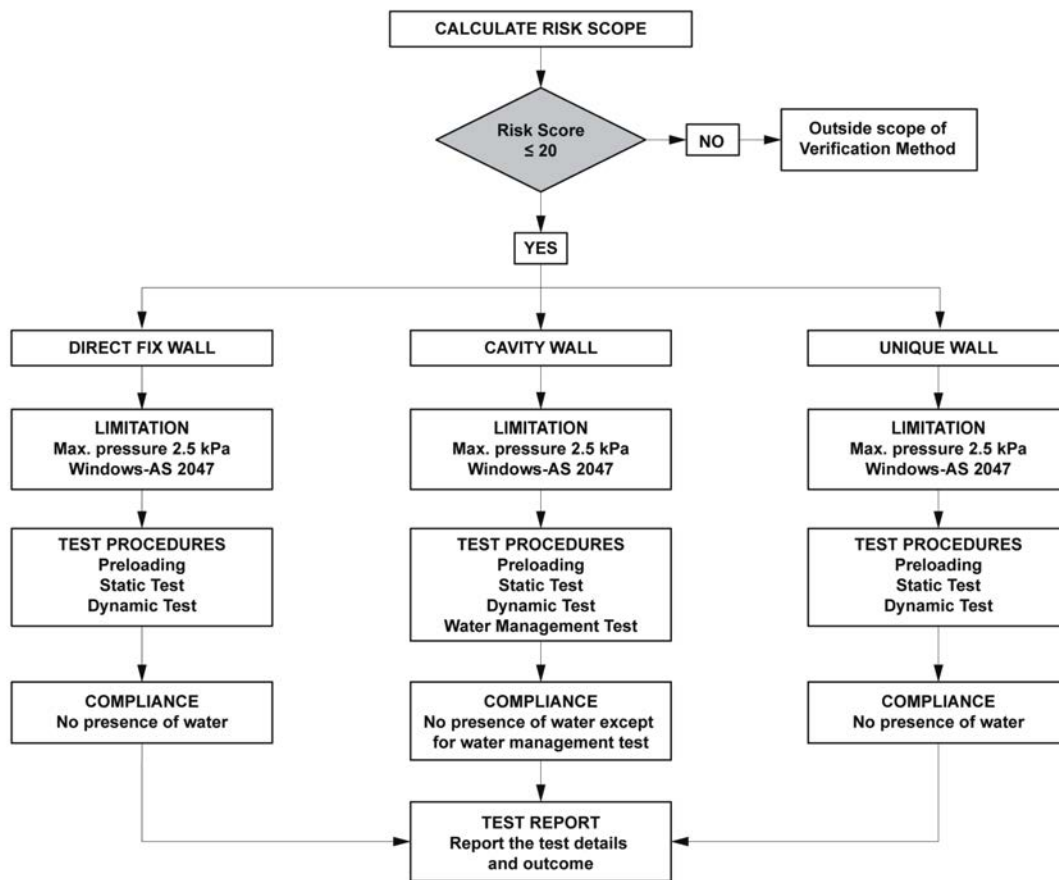

Risk factors—Table FV1.1

The risk score is determined by a number of factors including:

- wind region;
- number of storeys;
- type of roof/wall junctions;
- eave widths;
- complexity of the building envelope; and
- types of decks and balconies.

The following are examples of typical roof/wall junctions and their associated exposure or protection categories:

- a hip and gable roof with eaves is considered to have fully protected roof-to-wall junctions;
- a hip and gable roof with no eaves is considered to have partially exposed roof-to-wall junctions;
- parapets, enclosed barriers or eaves at greater than 90° to vertical with soffit lining are considered fully exposed roof-to-wall junctions; and
- lower ends of aprons, chimneys, dormer windows and the like are considered roof elements finishing within the boundaries formed by the external walls.

Building envelope complexity is determined by the shape and the amount of cladding used. FV1.1 includes both simple and complex shaped buildings:

- A simple shaped building includes rectangular, L or T shaped buildings.
- A complex shaped building includes a building with angular or curved shapes such as a Y shaped building.

Test specimen—FV1.1(b)

Representative samples of openings and joints must be included to test the whole cladding system.

This includes samples of:

Health and amenity

- vertical and horizontal control joints;
- wall junctions;
- windows or doors;
- electrical boxes;
- balcony drainage (i.e. to prevent water pooling against the external wall) and parapet flashings; and
- footer and header termination systems (i.e. a header termination system is where a cladding finishes at the top of a window).

A test specimen is illustrated in [Figure FV1.1\(2\)](#).

Figure FV1.1(2)

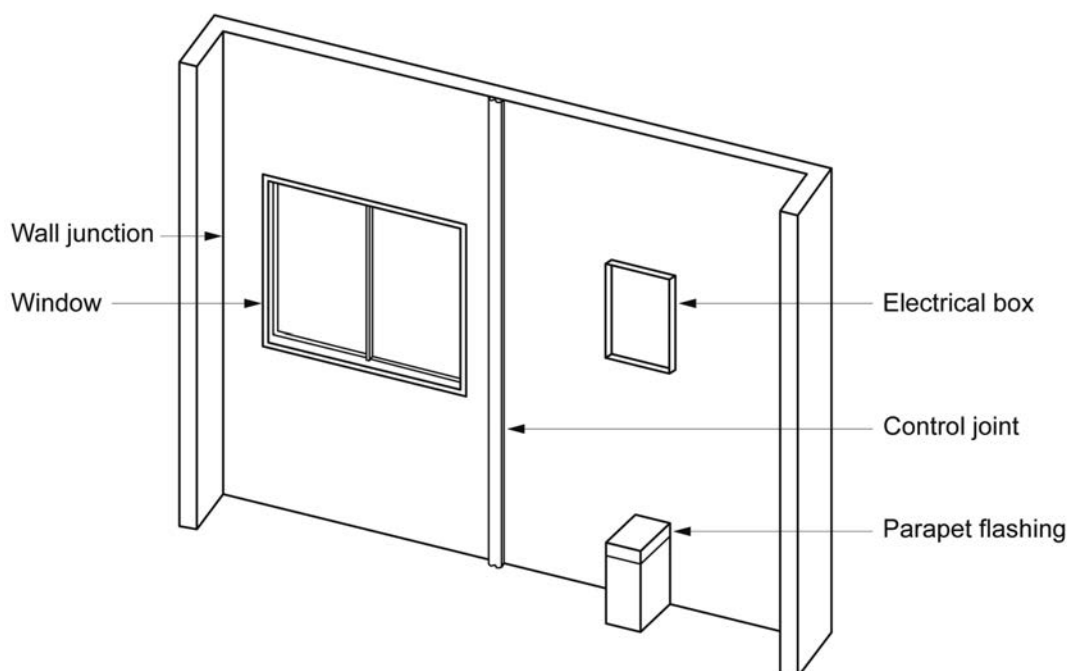

Where a cavity wall is tested, a transparent material must be used in lieu of a portion of the internal wall lining. The transparent material will be used during the testing to observe any water penetration. To ensure an unobstructed view of the external wall occurs, other building components such as building membranes must be removed for the extent of the transparent opening within the internal wall lining. It should be noted that for the purposes of [FP1.4](#) building membranes are not a requirement. However a membrane can be used to achieve compliance with [FV1.1](#).

The transparent material must be installed to maintain similar air tightness as the intended internal wall lining. To simulate the effects of power points, light switches and other similar openings which may cause air leakage, a 15 mm diameter hole must be placed in the internal wall lining below the window.

Test procedure—[FV1.1\(c\)](#)

The test procedure requirements vary in relation to two sub-clauses. [FV1.1\(c\)\(i\)](#) specifies the test procedure for a direct fix cladding wall or a unique wall. [FV1.1\(c\)\(ii\)](#) specifies the requirements for cavity wall construction. The difference between the two sub-clauses is [FV1.1\(c\)\(ii\)](#) has an additional water management test. This is due to cavity wall construction being designed to allow water to pass through the primary weather-defence (e.g. the skin of masonry on a masonry veneer wall), with the function of the cavity allowing for the removal of any water.

Direct fix cladding wall and unique wall—[FV1.1\(c\)\(i\)](#)

The test procedure for [FV1.1\(c\)\(i\)](#) contains three steps:

- Apply a preconditioning loading to the external face of the wall, by placing 100% positive and 100% negative (suction) serviceability wind pressure to the external wall. The serviceability wind pressure will be determined by the location in which the wall is going to be installed. However, due to the limitations of the Verification Method, the ultimate state wind pressure can be a maximum of 2.5 kPa. For a vented cavity wall, the end sections of the cavity must be sealed and the material serving as the air seal must be able to withstand the same applied loading as the wall being tested.

Health and amenity

- Conduct a static pressure test at 30% of the serviceability wind pressure or 300 Pa, whichever is higher. [FV1.1\(c\)\(i\)\(B\)](#) refers to clause 8.5.2 of AS/NZS 4284 for the requirements of this test.
- Conduct a cyclic pressure test in accordance with clause 8.6.2 of AS/NZS 4284, tested over the three stages specified in [Table FV1.2](#).

Cavity walls—FV1.1(c)(ii)

The test procedure for [FV1.1\(c\)\(ii\)](#) contains four steps:

- The first two steps are identical to [FV1\(c\)\(i\)](#) in respect to the preconditioning loading test and the static pressure test.
- The third test, the cyclic pressure test, is slightly different to the cyclic pressure test in [FV1.1\(c\)\(i\)](#). The test is still required to be in accordance with clause 8.6.2 of AS/NZS 4284. However, instead of testing three stages of [Table FV1.2](#), [FV1.1\(c\)\(ii\)\(C\)](#) only requires one test, using serviceability wind pressures of stage three of [Table FV1.1](#). Only one cyclic pressure test is required as the water management test in [FV1.1\(c\)\(ii\)\(D\)](#) requires additional tests; one additional cyclic test and two additional static pressure tests.
- [FV1.1\(c\)\(ii\)\(D\)](#) contains the additional testing requirements for a cavity wall. This test represents the failure of the primary weather defence or sealing. The primary weather defence includes the wall material, any flashings and sealing of joints and openings.

Compliance—FV1.1(d)

Similar to the test procedure, the compliance requirements are separated into two parts and are subject to the type of wall being tested.

[FV1.1\(d\)\(i\)](#) specifies the compliance requirements for a direct fix cladding wall and a unique wall. Compliance for the testing of these types of walls is met by no presence of water to the inside surface of the facade. This includes the surface of the external wall which is fixed to the internal wall, or for a single skin wall, the internal wall.

The compliance requirements for a cavity wall in [FV1.1\(d\)\(ii\)](#) are different to the requirements for a direct fix cladding wall or unique wall. This is due to the purpose and nature of a cavity wall. Water which passes through the primary weather-defence will gradually be removed from the cavity either through weep holes or evaporation. [FV1.1\(d\)\(ii\)](#) therefore allows water to enter the cavity provided water is not present on the removed surface of the cavity. However, there are some exemptions to this, as the water may transfer to the removed surface through an isolated blemish due to the introduced defects. Also, water can contact cavity surfaces such as battens. However, it must be demonstrated that the water will be able to be removed from these surfaces.

The removed surface of the cavity will generally be the outer surface of the internal wall, for example, where the building membrane would be attached to a stud frame.

The purpose of the test report in [FV1.1\(e\)](#) is to record the details and the outcomes of the test. This is common for any test procedure.

FV1.2 Overflow protection

[FV1.2](#) allows the use of vessels with built-in overflow to provide overflow capacity rather than through the use of a floor waste or other means.

Part F1 Damp and weatherproofing

Deemed-to-Satisfy Provisions

F1.0 Deemed-to-Satisfy Provisions

Intent

To clarify that the requirements of [FP1.1](#) to [FP1.7](#) will be satisfied if compliance is achieved with [F1.1](#) to [F1.13](#).

The BCA does not contain any Deemed-to-Satisfy Provisions which can be followed as a means of complying with [FP1.4](#) for water penetration through external walls. However, it is still compulsory to comply with this Performance Requirement. This approach has not changed from the previous edition of the BCA.

F1.1 Stormwater drainage

Requires compliance with AS/NZS 3500.3 to achieve compliance with the Performance Requirements.

F1.2 * * * * *

In BCA 90, this provision was performance-based. In subsequent editions of the BCA, the provision is covered by the Performance Requirements. [F1.2](#) has been left blank rather than renumber subsequent clauses.

F1.3 * * * * *

In BCA 90, this provision was performance-based. In subsequent editions of the BCA, the provision is covered by the Performance Requirements. [F1.3](#) has been left blank rather than renumber subsequent clauses.

F1.4 External above ground membranes

External above ground membranes to comply with AS 4654 Parts 1 and 2

[F1.4](#) references the Standard for waterproofing membranes for external above ground use.

F1.5 Roof coverings

Intent

To prevent water penetration of roofs which could cause:

- (a) unhealthy and dangerous conditions or loss of amenity for occupants; or
- (b) dampness and deterioration of building elements.

Roofing materials and fixing methods

[F1.5](#) contains reference to Australian Standards and other reference documents for a range of roofing materials and fixing methods suitable for the prevention of water penetration.

Concrete and terracotta tiles — cyclonic areas

[F1.5\(a\)](#) and [\(b\)](#), with regard to the use of concrete and terracotta roofing tiles, are not applicable to cyclonic areas, because the AS 2050 fixing details are inadequate for use in such areas. Accordingly, fixing in cyclonic areas must be approved by the appropriate authority.

F1.6 Sarking

Intent

To prevent water penetration of roofs and walls which could cause:

- (a) unhealthy and dangerous conditions or loss of amenity for occupants; or
- (b) dampness and deterioration of building elements.

Sarking to comply with AS/NZS 4200 Parts 1 and AS 4200 Part 2

Health and amenity

F1.6 references the Standard for sarking materials where sarking is required for weatherproofing roofs and walls (eg under roof tiles or on walls before weatherboards are fixed).

F1.7 Waterproofing of wet areas in buildings

Intent

To prevent water penetration from wet areas in buildings which could cause:

- (a) unhealthy and dangerous conditions or loss of amenity for occupants; or
- (b) dampness and deterioration of building elements.

Wet areas to be impervious to water

F1.7 requires that certain areas designated as “wet areas” be made impervious to water. This applies to showers, floors and walls adjacent to baths, tubs or laundry troughs, basins, sinks and urinals. The aim is to protect adjacent areas from damage by water splashed from these fixtures.

Adoption of AS 3740 — F1.7(a) and (b)

Class 2 and 3 buildings and Class 4 parts of buildings must be impervious to water in accordance with the design and construction requirements of AS 3740 in the locations listed in [Table F1.7](#).

Similar design and location requirements apply for a bathroom, shower room, slop hopper, sink compartment, laundry or sanitary compartment in a Class 5, 6, 7, 8 or 9 building. [Table F1.7](#) determines when a building element is required to be waterproof or water resistant, while how to make the building element waterproof or water resistant is determined by AS 3740.

The defined terms for shower area, vessel, waterproof, water resistant and wet area are located under [Schedule 3](#).

F1.8 * * * * *

In BCA 90, this provision was performance-based. In subsequent editions of the BCA, the provision is covered by the Performance Requirements. F1.8 has been left blank rather than renumber subsequent clauses.

F1.9 Damp-proofing

Intent

To prevent moisture from the ground penetrating a building where it could cause:

- (a) unhealthy and dangerous conditions or loss of amenity for occupants; or
- (b) dampness and deterioration of building elements.

Damp must not rise from the ground — F1.9(a)

Damp must be prevented from reaching:

- a building’s lowest floor timbers;
- suspended concrete floors or other suspended floors;
- supporting beams or girders; and
- walls above damp-proof courses.

Damp-proof course — AS/NZS 2904 or AS 3660.1 — F1.9(b)

AS/NZS 2904 and AS 3660.1 are referenced as alternative options for damp-proof course materials and installation details.

Exemptions — F1.9(c)

F1.9(c) contains exemptions to F1.9(a) because the safety level of buildings will not be significantly diminished by moisture from the ground.

F1.9(c)(i) regarding Class 7 and Class 8 buildings refers only to such buildings which, in a particular case, do not exhibit any need for compliance with F1.9. Such buildings must be considered on a case-by-case basis. However, it is the responsibility of a building proponent to satisfy the appropriate authority that the exemption should apply.

F1.10 Damp-proofing of floors on the ground

Intent
<p>To prevent moisture from the ground penetrating a building where it could cause:</p> <ul style="list-style-type: none"> (a) unhealthy and dangerous conditions or loss of amenity for occupants; or (b) dampness and deterioration of building elements.

Damp must not rise from the ground

F1.10 covers floors resting on the ground. The aim is to prevent ground dampness causing:

- unhealthy and dangerous conditions or loss of amenity for occupants; or
- dampness and deterioration of building elements (which, in this case, includes surfaces and linings inside the building, such as floor tiles, wall paint and the like).

Vapour barriers — AS 2870

AS 2870 is referenced for acceptable materials and installation details for vapour barriers to stop ground moisture reaching the upper surface of floors and walls.

Exemptions — F1.10(a) and (b)

Exemptions apply to F1.10 where:

- weatherproofing is not required for Class 7 or Class 8 buildings where there is no necessity for compliance, sheds forming part of a building used for other purposes, and so on (see the Limitations to FP1.4 for a listing of exempted buildings); and
- the base of a stairway or lift or similar shaft is suitably drained.

Figure F1.10 illustrates a method of installing damp-proofing in subfloor structures.

Figure F1.10 Installation of DPC in subfloor structures

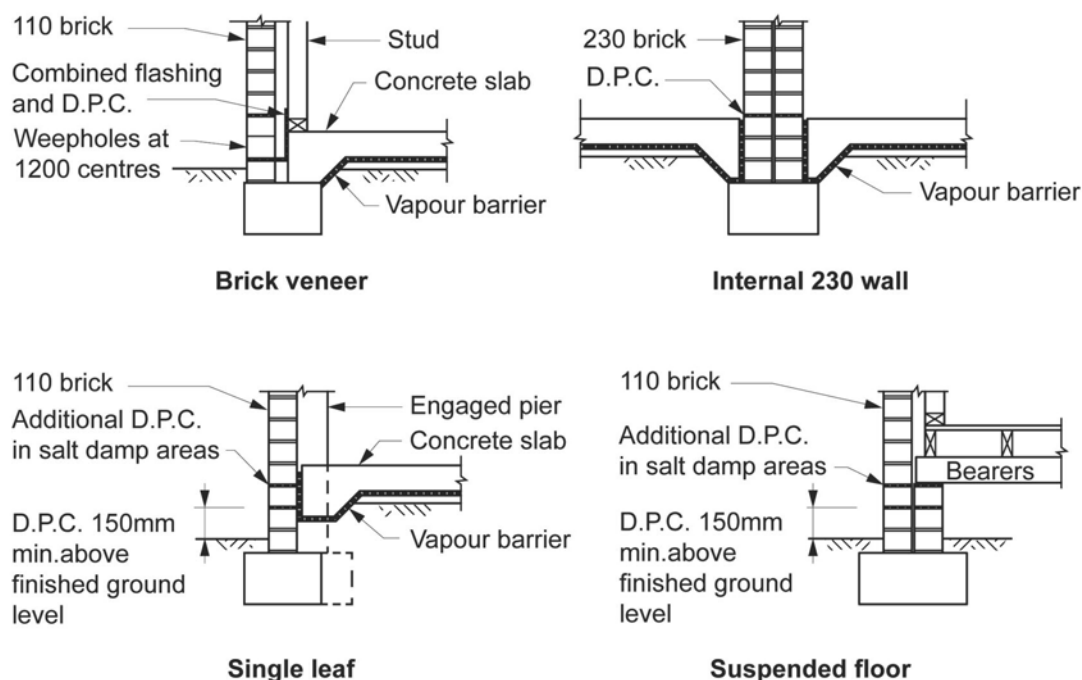

F1.11 Provision of floor wastes

Intent
<p>To prevent water from any bathroom or laundry in Class 2 and Class 3 buildings or Class 4 parts from penetrating any sole-occupancy unit or public space, which is in a level below, which could cause:</p>

Health and amenity

- (a) unhealthy and dangerous conditions or loss of amenity for occupants; or
- (b) dampness and deterioration of building elements.

Floor wastes are to be installed in bathrooms and laundries in Class 2 and Class 3 buildings and Class 4 parts, where those bathrooms and laundries are above another sole-occupancy unit or public space.

The aims of this requirement are to minimise water overflows from fixtures in the specified rooms:

- causing costly and possibly dangerous water damage to other sole-occupancy units;
- creating unhealthy conditions in public spaces in buildings; and
- disrupting and intruding on neighbours in the unit below.

F1.12 Subfloor ventilation

Intent

To prevent rising dampness which could cause:

- (a) unhealthy and dangerous conditions or loss of amenity for occupants; or
- (b) dampness and deterioration of building elements.

Subfloor ventilation is cross ventilation of the subfloor space between the underside of the floor and ground surface under the lowest suspended floor of a building.

Ground moisture rising into or entering the subfloor space can create a damp environment which encourages timber rot, fungus growth and the potential for termite activity. Subfloor ventilation increases air flow, reducing any damaging water vapour in the subfloor space.

Factors that can affect achieving satisfactory levels of subfloor ventilation include height above ground, prevailing breezes (air transfer), differential temperature and humidity between the subfloor and the external environment and good building practice.

The amount of subfloor ventilation required for a building is related to the relative humidity likely to be encountered in that location. For the purposes of the Deemed-to-Satisfy Provisions, Australia has been divided into three broad climatic zones based on the prevailing relative humidity.

The climatic zones were determined by analysis of the average relative humidity at 9 am and 3 pm in January and July. The season with the highest relative humidity is used. Generally this is July for southern Australia and January for northern Australia. The climatic zone limits are described in [Figure F1.12](#).

[Table F1.12](#) specifies the minimum amount of subfloor ventilation openings and height of subfloor framing members above ground level for the three climatic zones illustrated in [Figure F1.12](#). The table allows subfloor ventilation rates to be halved if the ground within the subfloor space is sealed by an impervious membrane because humidity levels in the space will not be affected by moisture from the soil.

[F1.12\(e\)](#) specifies additional requirements for preventing deterioration of subfloor members where the ground or sub-floor space is excessively damp, as would occur in areas with high water tables, poor drainage or in areas frequently affected by flooding or water inundation.

F1.13 Glazed assemblies

Intent

To prevent water penetration of windows which could cause:

- (a) unhealthy and dangerous conditions or loss of amenity for occupants; or
- (b) dampness and deterioration of building elements.

[F1.13](#) requires windows, etc to comply with the AS 2047 requirements for resistance to water penetration. The provision does not apply to:

- some Class 7 and 8 buildings;
- garages, tool sheds, sanitary compartments and the like forming part of a building used for other purposes; and
- open spectator stands and open-deck carparks.

The exemptions are consistent with limitations in [FP1.4](#) (see [FP1.4](#)).

Part F2 Sanitary and other facilities

Objective

FO2

The Objective of this Part is to—

- (a) safeguard occupants from illness caused by infection; and
- (b) safeguard occupants from loss of amenity arising from the absence of adequate personal hygiene facilities; and
- (c) enable occupants to carry out laundering; and
- (d) provide for facilities to enable food preparation; and
- (e) enable unconscious occupants of sanitary compartments to be removed from the compartment.

Examples

- The BCA requires sanitary facilities to be installed at a rate based on the number of people in a building. If insufficient, unacceptable queuing may result.
- Loss of amenity can occur if users are not provided with sufficient privacy.

Adequate laundry and cooking facilities should be available to health-care buildings and early-childhood centres, as well as residents of Class 2 buildings and Class 4 parts of a building.

Functional Statements

FF2.1

A building is to be provided with—

- (a) suitable sanitary facilities and space and facilities for personal hygiene; and
- (b) adequate means for the prevention of contaminants to hot water, warm water and cooling water systems.

FF2.2

A building is to be provided with—

- (a) space or facilities for laundering; and
- (b) suitable means for the sanitary disposal of waste water.

Application:

[FF2.2](#) only applies to—

- (a) a Class 2 building or Class 4 part of a building; and
- (b) a Class 9a health-care building; and
- (c) a Class 9b early childhood centre; and
- (d) a Class 9c building.

Health-care buildings, early-childhood centres, Class 2 and 9c buildings and Class 4 parts of a building must be provided with laundry facilities. Under the [FF2.2](#) Application provision, [FF2.2](#) does not apply to any other buildings.

Class 2 and 9c buildings and Class 4 parts of a building are required to have laundry facilities and means to dispose of waste water because occupation is generally of a permanent nature. This is not the case in other buildings. For example, a hotel, motel or boarding school may have its own laundry facilities, or have an arrangement with a commercial laundry. Sole-occupancy units in Class 3 buildings are not occupied by the same people for extended periods of time, so they are not required to be provided with laundry facilities or means to dispose of waste water.

FF2.3

A building is to be provided with—

Health and amenity

- (a) space and facilities for the preparation and cooking of food; and
- (b) suitable means for the sanitary disposal of associated waste water.

Application:

FF2.3 only applies to—

- (a) a Class 2 building or Class 4 part of a building; and
- (b) a Class 9a health-care building; and
- (c) a Class 9b early childhood centre; and
- (d) a Class 9c building.

Health-care buildings, early-childhood centres, Class 2 and 9c buildings and Class 4 parts of a building must be provided with cooking facilities. Under the FF2.3 Application provision, FF2.3 does not apply to any other buildings.

As for laundry facilities, Class 2 and 9c buildings and Class 4 parts of a building are required to have cooking facilities because their occupation is generally of a permanent nature. Cooking facilities are also required in health-care buildings and early-childhood centres because the occupants of these places may require specific types of food not easily available from outside (eg special dietary needs).

Cooking facilities are not required in other buildings. For example, a hotel, motel or boarding school may have its own cooking facilities, have an arrangement with a commercial caterer, or choose to have no cooking facilities at all. It is assumed that the same people do not occupy sole-occupancy units in Class 3 buildings for extended periods of time, so they are not required to be provided with cooking facilities.

FF2.4

A sanitary compartment is to have sufficient space or other means to permit an unconscious occupant to be removed from the compartment.

Performance Requirements**FP2.1 Personal hygiene facilities**

FP2.1 recognises that the number, type and location of sanitary facilities are dependent on:

- what the building is used for; and
- the number, gender and particular needs of the occupants.

FP2.2 Laundry facilities

Health-care buildings, early-childhood centres, Class 2 and 9c buildings and Class 4 parts of a building must be provided with means to dispose of waste water and either:

- laundry facilities; or
- space for laundry facilities.

A building's function or use will determine the appropriate number and location of the laundry facilities or space, and the means to dispose of waste water.

For the purpose of FP2.2, waste water includes water that is soiled as a result of clothes washing, mopping floors, and other domestic cleaning processes.

FP2.3 Kitchen facilities

Health-care buildings, early-childhood centres, Class 2 and 9c buildings and Class 4 parts of a building must be provided with adequate cooking facilities. This means:

- washing facilities for both food and utensils used for the preparation and consumption of food, in conjunction with adequate waste water disposal;
- a means of cooking food, which may be either fixed in place (such as a wall-mounted oven) or a removable appliance (such as a microwave unit); and
- space to allow food to be prepared.

FP2.4 Disposal of contaminated water from containers

Class 9a and 9c buildings with wards or bedrooms must have facilities for emptying bedpans and the like, such as a slop hopper.

FP2.5 Construction of sanitary compartments to allow removal of unconscious people

Sanitary compartments are to be large enough or have another suitable means that enables the removal of an unconscious occupant.

FP2.6 Microbial control for water systems

Buildings must have hot water, warm water and cooling water installations that minimise the risk of major disease outbreak caused by the harmful levels of micro-organisms.

This Performance Requirement does not apply to a system serving only a single sole-occupancy unit in a Class 2 or 3 building or Class 4 part of a building.

Verification Methods

FV2.1 Sanitary facilities

FV2.1 enables the use of queuing modelling to demonstrate that the occupant waiting time for sanitary facilities is at least equivalent to the waiting time predicted using the respective Deemed-to-Satisfy Provisions.

Overview of the modelling process

Sanitary facilities and their users are an example of a queuing system. In the usual terminology, a queuing system is made up of one or more servers and a number of customers to be served. In the case of sanitary facilities the servers are the fixtures (closet pans, urinals, wash basins) and the customers are the users of each type of fixture. Any one building may have a number (up to five) more or less separate and independent queuing systems:

- For males—closet pans, urinals, wash basins
- For females—closet pans, wash basins.

A queuing system is defined by—

- the number of servers (= fixtures) and the statistical distribution of service time (= occupancy time);
- the statistical distribution of arrival times of customers (= users); and
- a queue protocol (assumed to be first in first out denoted by FIFO).

It is assumed that the population of customers is effectively infinite, except for cases where there is a pronounced interval effect, as in the case of theatre intermission, and that there is no physical limit on queue size (which may arise due to space limitations for example), but there may be some avoidance behaviour on the part of users if queue length (and expected waiting time) become excessive.

The analysis of queuing systems can be complex. Under certain assumptions, closed form expressions can be derived for the key parameters that describe the performance of a queuing system. The particular type of queuing system which is most straightforward to analyse is based on the assumption that the arrival times can be described by a Poisson distribution. A Poisson distribution is fully defined by a single parameter, denoted by the Greek letter λ , which turns out to be the arrival rate (number of arrivals per unit time).

The Poisson distribution has two properties that render its use attractive. Firstly it is memoryless i.e. the probability of an arrival at any time is independent of the past history of the system (for example, whether there has been another recent arrival). The second property is that the inter-arrival times follow the geometric distribution with a mean arrival time of $1/\lambda$. The Poisson distribution is the only process that has these properties.

Occupancy times in a simple queuing system are also assumed to have the geometric distribution with mean value denoted by $1/\mu$. Thus the servers (times when users finish with a fixture) is also a Poisson process with parameter μ . Once again, this has the memoryless property (the probability of a user finishing with a fixture is independent of the occupation time up to that point).

The queuing system described above is often referred to as a M/M/c system where c denotes the number of fixtures of a certain kind and for each sex (the use of M signifies memoryless).

Where the queuing system has been allowed to settle into a steady state a full analysis is possible and the following parameters can be determined:

Health and amenity

- The traffic density (= the ratio of mean occupancy time ($1/\mu$) divided by the number of fixtures (c) to mean inter-arrival time ($1/\lambda$): this ratio must be less than one or the queue grows without bound, $\lambda/(c\mu) < 1$).
- The probability that nobody is in the system (no one of the specified sex is using the specified type of fixture).
- The probability that a user will need to wait.
- The mean waiting time.
- The waiting time cumulative distribution function: this provides an estimate of the proportion of occurrences when a user arriving at a facility will need to wait more than a specified time (or the probability that a user will have to wait more than a specified time).

$$p_0 = \left[\sum_{j=0}^{c-1} \left(\frac{\lambda}{\mu} \right)^j \frac{1}{j!} + \left(\frac{\lambda}{\mu} \right)^c \frac{c\mu}{c!(c\mu - \lambda)} \right]^{-1}$$

$$w = \frac{p_0 \mu \left(\frac{\lambda}{\mu} \right)^c}{(c-1)!(c\mu - \lambda)^2}$$

$$P(w > t) = \frac{p_0 c \mu (\lambda/\mu)^c}{c!(c\mu - \lambda)} e^{-(c\mu - \lambda)t}$$

Part F2 Sanitary and other facilities

Deemed-to-Satisfy Provisions

F2.0 Deemed-to-Satisfy Provisions

Intent

To clarify that complying with [Part F2](#) and, for public transport buildings, [Part H2](#), and for farm sheds [Part H3](#), will satisfy the requirements of [FP2.1-FP2.6](#).

F2.1 Facilities in residential buildings

Intent

To specify the minimum acceptable sanitary, bathing, laundry and cooking facilities required in Class 2 buildings, Class 3 buildings (for residents only), Class 9c buildings (for residents only) and Class 4 parts of a building.

[F2.1](#) lists the type and number of facilities required in Class 2 buildings, Class 3 buildings (for residents only), Class 9c buildings (for residents only) and Class 4 parts of a building. The reason that residential care buildings are included is that they are regarded as residential buildings because they are the residents' home. All the listed facilities are to be provided separately.

For laundry facilities—Class 2 buildings and Class 4 parts of a building must be provided with a means to wash clothes. In Class 2 buildings, laundry facilities must be provided as follows:

- within each sole-occupancy unit:
 - at least one washtub; and
 - at least one space for a washing machine; or
- as a separate group for each four (or less) sole-occupancy units:
 - a washtub; and
 - at least one washing machine.

Example

In a Class 2 building or Class 4 part of a building, a washbasin and a washtub are required. Although the placing of laundry facilities in a bathroom is permitted, a separate washbasin and washtub are still required.

Class 4 parts of a building must be provided with at least one washtub and at least one space for a washing machine.

A washtub provided to a Class 2 building or Class 4 part of a building provides the necessary means to dispose of waste water as required by [FP2.2](#).

For drying clothes—Class 2 buildings and Class 4 parts of a building must be provided with some means to dry clothes. In Class 2 buildings, clothes-drying facilities must be provided as follows:

- within each sole-occupancy unit:
 - at least 7.5 metres of drying line; or
 - at least one space for a drying cabinet or appliance; or
- as a separate group for each four (or less) sole-occupancy units:
 - at least 7.5 metres of drying line per sole-occupancy unit; or
 - at least one drying cabinet or appliance.

Class 4 parts of a building must be provided with at least one clothesline or hoist; or at least one space for a drying cabinet or appliance.

For food—in Class 2 buildings (in each sole-occupancy unit) and Class 4 parts of a building, the following must be provided:

- at least one kitchen sink; and
- facilities for the preparation and cooking of food (see [FP2.3](#)).

For bathing and toiletry in residences—at least either one bath or shower, and at least one closet pan and one washbasin must be provided:

Health and amenity

- in each sole-occupancy unit in Class 2 buildings;
- for each 10 residents (or less) in a Class 3 building or group of buildings for whom private facilities are not provided (note the concession where urinal facilities are provided); and
- in each Class 4 part of a building.

For Class 3 building facilities—the patrons' facilities may be grouped together and do not need to be in the building where sleeping accommodation is provided.

Example

An example of grouped facilities could be sanitary facilities located in a freestanding ablution block that services several accommodation units.

The facilities for a Class 3 building (other than a residential care building) contained in [F2.1\(b\)](#) are those for the residential portion of the building only. Facilities for employees in Class 3 buildings are contained in [Table F2.3](#).

For Class 9c buildings—the facilities listed in [F2.3\(e\)\(i\)](#) apply to the residential portion of Class 9c buildings only. The kitchen and laundry facilities listed in [F2.1\(e\)\(ii\)](#) need not be located in the resident use area. The clinical hand washing basin listed in [F2.1\(e\)\(ii\)\(C\)](#) is intended for use by staff, etc. and therefore would be best placed in the resident use area. Sanitary facilities for employees in Class 9c buildings are contained in the general part of [Table F2.3](#). They can be utilised by the occupants when required.

F2.2 Calculation of number of occupants and facilities

Intent

To provide a method for calculating the number of occupants and facilities for the purposes of [Part F2](#).

If the number of people who will occupy a building is known, it should be used. However, in the absence of more accurate information, [D1.13](#) must be used. [D1.13](#) is used in several Parts of the BCA, such as in calculating minimum exit widths, as well as the number of sanitary and other facilities. [D1.13](#) does not restrict the number of occupants using a building, or enforce any building use or licensing requirements. Refer also to comments on [D1.13](#).

As specified in [D1.13\(b\)](#), if the building is an assembly building or room, its fixed seating provisions give an indication of capacity.

Any other suitable means, as specified in [D1.13\(c\)](#), may include a statement from the building owner as to the number of occupants where there is limited public access.

Example

An alternative means of assessing the number of occupants may be appropriate in the following case.

A specific restaurant may have fixed tables, booths, dining alcoves and architectural features which occupy a significant proportion of the floor space, so the actual number of patrons able to be accommodated may be much less than the number calculated using the one person for every square metre of floor area in [D1.13](#).

In such a case, it may be appropriate to count the number of seats available for use by patrons or some other method. However, due allowance would need to be made for the employees, as well as the potential for alternative seating layouts which could then increase the number of people in the restaurant.

For consideration of gender—the number of sanitary facilities should be calculated on the basis that the population of males and females in a building will usually be about equal. Where a building will be occupied predominantly by one sex, the proportion of sanitary facilities can be adjusted accordingly.

Examples

It may be appropriate to vary the proportion of female and male sanitary facilities in:

- a gymnasium which has appropriate permission to cater for a single sex;
- a single-sex sports facility, such as either an all-male football club or an all-female netball club;
- all-male or all-female prisons; and
- medical or hospital facilities that cater for a specific sex, such as prostate-cancer specialists, gynaecological clinics and maternity hospitals.

For unisex facilities—under [F2.2\(c\)](#), a required unisex facility for people with a disability can be counted as a facility for both males and females. It should be noted that [F2.2\(c\)](#) does not apply to unisex facilities for people with a disability that are provided in addition to the number required by the NCC.

Health and amenity

F2.2(d) defines the meaning of 'unisex facility' for the purposes of Part F2. It is important to note that a sanitary compartment suitable for a person with an ambulant disability is not a unisex facility and cannot be counted as a facility for both males and females under F2.2(c).

Examples

If there is a requirement for a toilet block to contain 10 closet pans for males and 10 closet pans for females (a total of 20 closet pans), they may be provided as a total of 19 closet pans, i.e.:

- 9 male;
- 9 female; and
- 1 unisex facility for people with a disability.

A similar approach can be used for the number of washbasins required.

In another case where there is a requirement for 1 closet pan for males and 1 closet pan for females, providing a single unisex facility may satisfy this requirement. However, if a urinal is also required it cannot be in the unisex facility; it must be in an area reserved for use by males.

F2.3 Facilities in Class 3 to 9 buildings**Intent**

To specify the minimum acceptable sanitary, bathing, laundry and cooking facilities required in Class 3 buildings (for employees only) and in Class 5-9 buildings.

F2.3 and Table F2.3 contain the requirements for the type and number of facilities required. They are based on the premise that a higher ratio of sanitary facilities is required in buildings where occupants spend a long time.

Example

A higher ratio of sanitary facilities is required in a Class 7 or Class 8 workplace (where employees could spend all day) than in a Class 6 department store (where customers could be expected to spend less time).

F2.3(a) requires the separation of male and female toilets. F2.3(b), (c) and (f) provide specific exemptions permitting unisex and combined facilities in some circumstances. Figure F2.3 shows an example of a typical layout that meets the requirement for separate facilities under F2.3(a).

Figure F2.3 Example of a typical layout for separate facilities

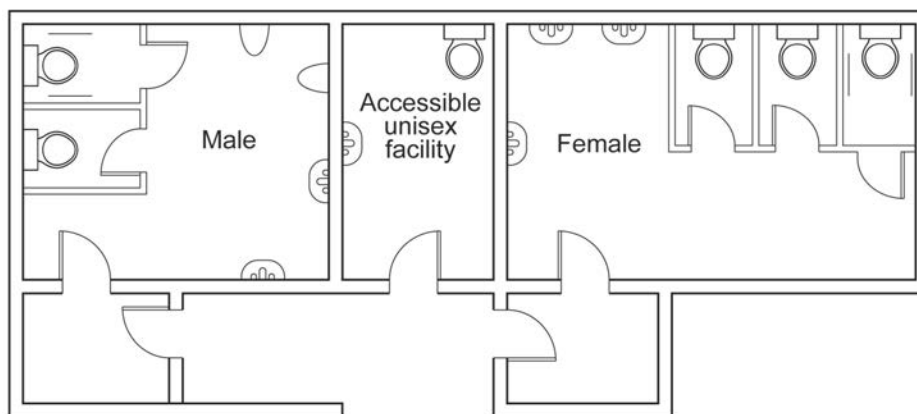

Except in schools and early-childhood centres, separation of facilities for employees and the public is not required (see F2.3(d)). Separation is required in schools to maintain the teacher/student relationship, while in early-childhood centres it is required because of the:

- provision of junior pans;
- use of the facilities for hygiene training purposes; and
- need to keep the children under observation.

Sanitary facilities for females must be provided with a means of disposal of sanitary products (see F2.3(e)). This might include an incinerator, or a bin and disposal service. This provision also applies to unisex or male/female shared facilities permitted by F2.3(b) and (c).

F2.3(f) provides an exemption to (a) for ward areas in a Class 9a building. This allows for unisex facilities for operational

Health and amenity

requirements such as flexible bed allocations.

For health-care buildings—in addition to [Table F2.3](#), [F2.3\(g\)](#) requires facilities for preparing meals and laundering to meet the needs of patients and occupants residing in the building.

[F2.3\(g\)\(i\)](#) therefore requires:

- a kitchen or other facilities for the preparation and cooking or reheating of food;
- a kitchen sink for the washing of plates, cutlery, cooking utensils, and the like; and
- a washbasin for kitchen staff to wash their hands.

Because of the amount of linen and clothes requiring laundering in these buildings, [F2.3\(g\)\(ii\)](#) requires laundry facilities; or places for the holding and dispatching soiled linen, clothing, and the like; and the receipt and storage of clean linen.

For early childhood centres—[F2.3\(h\)\(i\)](#) requires a kitchen because young children may require food prepared on the premises, possibly in the form of special diets. The kitchen must comprise:

- facilities for the preparation and cooking of food for infants;
- a kitchen sink;
- separate hand washing facilities;
- space for a refrigerator and;
- child proof latches attached to any access door or gate to the kitchen facilities to prevent unsupervised entry to the kitchen by children younger than 5 years.

[F2.3\(h\)\(i\)](#) requires, if the centre accommodates children younger than 2 years, the kitchen to be designed and constructed to facilitate supervision of children in the centre. In some circumstances, such as in a large early childhood centre, supervision requirements may not be fully achievable. In these situations a Performance Solution may be required. For example, the solution may provide an option to be able to supervise the activities of children younger than 2 years while also engaging in the heating of baby bottles, an option which may not be possible with the main kitchen.

If the building accommodates children younger than 3 years, there may also be a need to carry out washing of nappies and other clothing. [F2.3\(h\)\(iii\)\(A\)](#) therefore requires the installation of laundry facilities (but not drying facilities) in these buildings comprising:

- a washtub; and
- space in the same room for a washing machine.

Other requirements for centres accommodating children younger than 3 years are also prescribed under [F2.3\(h\)\(iii\)\(B\)](#) and [F2.3\(h\)\(iii\)\(C\)](#).

[F2.3\(h\)\(iii\)\(B\)](#) requires a bench-type bath to be provided within 1 m of a nappy changing bench.

[F2.3\(h\)\(iii\)\(C\)](#) specifies the requirements for a nappy changing bench. The requirements in sub-clauses (aa) to (dd) require the nappy changing bench to be:

- within 1 m of a separate adult hand washing facility;
- not less than 0.9 m² in surface area for the top of the bench;
- not less than 850 mm and not more than 900 mm from the finished floor level to the top of the bench. This height range is specified for ergonomic and safety reasons;
- provided with a space not less than 800 mm high x 800 mm deep x 500 mm wide for the storage of steps; and
- provided in a location so that the play area is visible at all times, to allow adequate supervision of other children whilst changing a child.

Example:

A Class 6 department store has a total floor area of 2000 m². From information provided by the proponent for the development, 35 staff will be employed. The sales floor has an area of 1700 m². Applying [F2.2\(a\)](#) and [Table D1.13](#), the number of customers that could be expected to be accommodated is 567 persons (one customer for each 3 m² of sales floor area). Applying [F2.2\(b\)](#), an equal 50/50 gender ratio for both staff and customers is used.

The total number of persons accommodated is 602 (567+35). The number of facilities required by [Table F2.3](#) is set out below in [Table F2.3\(1\)](#).

Table F2.3(1) Calculation of number of sanitary facilities—Class 6 department store

User group	Design occupancy	Number of closet pans	Number of urinals	Number of wash-basins
Male employees	17.5	1	1	1

Health and amenity

User group	Design occupancy	Number of closet pans	Number of urinals	Number of wash-basins
Female employees	17.5	2	-	1
Total employees	35	3	1	2
Male patrons	283.5	1	1	1
Female patrons	283.5	1	-	1
Total patrons	567	2	1	2
Overall total	602	5	2	4

Note:

The overall total number of closet pans and washbasins can be reduced by one for each sex where a unisex facility for people with a disability is provided (see [F2.2\(c\)](#)). The BCA does not require facilities for staff to be in an area separate from customers. Therefore a single toilet block with separate male and female facilities could be provided (see [F2.3\(d\)](#)) but a separation may be needed under some other regulations, such as workplace or health regulations, so should be checked.

In addition to [F2.3](#), Work Health and Safety legislation may require supplementary facilities. This can include showers and change rooms in some work places, depending on the nature of the work and working conditions of the employees.

F2.4 Accessible sanitary facilities**Intent**

To specify the minimum acceptable sanitary and bathing facilities required for people with a disability in Class 1b, Class 2, Class 3, Class 5-9 and Class 10a buildings.

[Section D](#) requires equitable and dignified access to buildings and the services they provide. [Section D](#) and [Part F2](#) are also intended to apply inclusively to people with a disability (see [FP2.1](#)). Not only must people with a disability be able to access a building's sanitary facilities, those facilities must be usable by them.

[F2.4\(a\)](#) and [\(b\)](#) refer to [Table F2.4\(a\)](#) and [Table F2.4\(b\)](#) respectively to determine the numbers of accessible sanitary facilities, and AS 1428.1 for details of the design of accessible facilities. Facilities such as washbasins, a shelf or bench top and adequate means of disposing of sanitary products must be inside the accessible unisex sanitary compartment and not outside in a public area. [F2.4](#) also requires sanitary compartments suitable for use by a person with an ambulant disability to be provided in certain circumstances, in addition to compartments for use by a person using a wheelchair. Where two or more of each type of unisex accessible sanitary facilities are provided in a building, the number of left and right handed mirror image facilities must be provided as evenly as possible. This is required because some people transfer from their wheelchairs from the right hand side and some from the left.

[Table F2.4\(a\)](#) provides minimum requirements for the provision of accessible unisex sanitary compartments, commonly referred to as unisex accessible toilets. Unisex accessible sanitary compartments are required on each storey where sanitary compartments are provided. If the male or female compartments are located separately and not in a single bank then the accessible unisex sanitary compartment is only required at one of those banks. However, clear directional information about the location of the closest accessible unisex sanitary compartment must be provided. If there are multiple banks containing male and female sanitary compartments on a storey, there must be an accessible unisex sanitary compartment at not less than 50% of those banks.

[Table F2.4\(b\)](#) provides minimum requirements for the provision of accessible unisex shower facilities in buildings where showers are required (by the NCC) to be provided.

[F2.4\(e\)](#) requires that facilities be constructed in accordance with AS 1428.1. It is important to note that AS 1428.1 contains provisions for both wheelchair accessible facilities and those for people with an ambulant disability. These provisions include:

- grabrails;
- circulation space;
- access door width and swing;
- height of fixtures;
- lever handles for taps; and
- space under the front of basins.

A sanitary compartment that is suitable for a person with an ambulant disability is not intended for use by a person using a wheelchair. Therefore an accessible path of travel need not be provided to such a compartment.

F2.5 Construction of sanitary compartments

Intent

To specify the construction expected to provide an acceptable level of privacy in sanitary compartments while facilitating assistance in an emergency.

Privacy in sanitary compartments is considered an amenity issue. There is a high level of privacy expected in unisex compartments while there are lower levels expected in early-childhood centres and facilities used by primary school children. There is also an intermediate level expected between sanitary compartments in single-sex sanitary facilities.

[F2.5](#) permits sanitary compartments in early childhood centres to be constructed without doors because it is necessary for staff to keep the children under regular observation. Under [F2.5\(a\)\(ii\)](#), a concession is also provided on the height of partitions for facilities used by primary school children. These concessions in [F2.5](#) should not be applied to staff facilities.

[F2.5\(b\)](#) requires means of removing an unconscious occupant from a fully enclosed sanitary compartment. If the enclosure has gaps that are large enough to allow access for a person into the sanitary compartment, the compartment is not intended to be considered enclosed for the purposes of this clause.

The exception to [F2.5\(b\)](#) is where there is a clear space of at least 1.2 m between the closet pan and the doorway, as measured in accordance with Figure F2.5 in the BCA.

Requirements for partitions between sanitary compartments for early-childhood centres is covered by [F2.5\(c\)](#). A partition must be opaque for a height of at least 900 mm but not more than 1200 mm, above the floor level, while the section above the partition may be open or clear glazed.

F2.6 Interpretation: Urinals and washbasins

Intent

To clarify what is meant by the expressions 'urinal' and 'washbasin'.

Urinals and hand-washing facilities are often not constructed as single units, but as a length of trough. [F2.6\(a\)](#) and [\(b\)](#) clarify that the words 'urinal' and 'washbasin' apply to individual facilities, or to a length of trough, in the case of a urinal; and a specific part of a hand-washing trough. The number of hand-washing facilities (washbasins) provided by a trough is determined by the number of water spouts serving the trough.

[F2.6\(a\)\(iii\)](#) allows a closet pan (also called a 'toilet pan' or 'closet fixture') to be used in place of a urinal. Such a closet pan must be additional to the required number of closet pans, and so must not be counted once as a urinal and once as a pan when calculating the total number of facilities.

F2.7 Microbial (legionella) control

Intent

To make sure that hot water, warm water and cooling water systems in certain facilities minimise the risk of a major disease outbreak.

Legionella and other dangerous bacteria may multiply in hot water, warm water and cooling water systems to numbers that can cause serious outbreaks. AS/NZS 3666.1, referenced by [F2.7](#), contains measures for designing, installing and commissioning hot water, warm water and cooling water systems, aimed at minimising the risk of a major disease outbreak.

This provision applies to all buildings except systems that only serve a single sole-occupancy unit in Class 2 or 3 building or Class 4 part. This limitation is consistent with the intent of AS/NZS 3666.1 and the limitation of [FP2.6](#).

F2.8 Waste management

Intent

To require adequate devices in Class 9a and 9c buildings containing ward areas or bedrooms for the emptying of containers of sewage and dirty water.

Class 9a buildings, such as hospitals and nursing homes, are likely to be occupied by people who can only carry out their toilet and bathing functions in commode chairs or into containers. To minimise disease, [F2.8\(a\)](#) requires slop-hoppers. These are special fixtures with a grate, flushing apparatus and tap which are used for emptying bedpans and the like.

Aged care buildings are likely to be occupied by people with similar difficulties to those occupying Class 9a buildings. To minimise disease, [F2.8\(b\)](#) requires the installation of slop-hoppers and appliances for either disinfecting pans or an

adequate means for disposal of receptacles in Class 9c buildings. If one device can undertake all tasks required by [F2.8\(b\)](#), then it may be utilised.

F2.9 Accessible adult change facilities

Intent

To provide for the installation of accessible adult change facilities in certain types of public building.

An accessible adult change facility is a type of sanitary compartment that includes a hoist and adult size change table in addition to a peninsula-type toilet pan and other fixtures and fittings. Its purpose is to provide a suitable toilet for people with more complex or profound disability who may be unable to use standard accessible toilets of the type required by [F2.4](#).

[F2.9\(a\)\(i\)](#) requires each accessible adult change facility to be constructed in accordance with [Specification F2.9](#), which sets out the technical requirements for these facilities.

[F2.9\(a\)\(ii\)](#) ensures that accessible adult change facilities are provided separately and in addition to any other sanitary compartment. Therefore, they cannot be counted when determining compliance with [F2.3](#) or [F2.4](#).

[F2.9\(b\)](#) sets out the types of public building where an accessible adult change facility must be provided.

[F2.9\(b\)\(i\)](#), [\(ii\)\(A\)](#), [\(iii\)](#) and [\(iv\)](#) are based on design occupancy which must be calculated in accordance with [F2.9\(c\)](#).

[F2.9\(b\)\(ii\)\(B\)](#) ensures that where a swimming pool in a Class 9b building is required to be accessible, it is provided with an accessible adult change facility.

[F2.9\(b\)\(v\)](#) ensures that accessible adult change facilities are provided in terminal buildings at airports. This provision only applies to airports that are also required to comply with the Disability Standards for Accessible Public Transport 2002.

[F2.9\(c\)](#) outlines how design occupancy must be calculated, and provides for certain areas to be excluded from such a calculation. The purpose of the exclusions is to ensure that buildings are assessed only on the basis of areas likely to be used by people with disability, thus ensuring consistent application of [F2.9](#) between different building layouts and sizes.

Specification F2.9**Accessible adult change facilities****Intent**

The intent of this Specification is to prescribe how an accessible adult change facility is to be designed and the equipment, fixtures and fittings that must be included in each facility.

Specification F2.9 is based on the Changing Places Information Guide and Technical Standard (June 2017 edition), copies of which can be obtained from the Changing Places website at: <https://changingplaces.org.au/>.

(Note: Changing Places is not in any way affiliated with, or endorsed by, the ABCB.)

Part F3 Room heights

Objective

FO3

The Objective of this Part is to safeguard occupants from injury or loss of amenity caused by inadequate height of a room or space.

Basis of Objective

FO3 is based on the belief that people should not be subject to risk of injury or loss of amenity caused by the inadequate height of a room or space.

Risk of injury

The height of certain rooms and spaces must be controlled to prevent injury to occupants.

Loss of amenity

The height of certain rooms and spaces must be controlled to prevent a loss of amenity to occupants.

Functional Statements

FF3.1

A building is to be constructed to provide height in a room or space suitable for the intended use.

Height suitable for use of a room or space

Buildings must provide a height suitable for the intended use of rooms and spaces. 'Intended use' recognises that the height required in rooms and spaces is directly related to the room's function.

Performance Requirements

FP3.1 Room or space heights

Intent

The intent of **FP3.1** is to ensure that the height of a room or space is sufficient for the intended use of the room or space. 'Intended use' recognises that the height required in a room or space is directly related to the room or space's intended function.

Sufficient height

FP3.1 adds the term 'sufficient' when describing the required level of performance. The required height must be considered in light of intended function.

The Deemed-to-Satisfy Provisions specify different heights for different room or building types.

Measurement of height

To achieve the requisite level of performance, it is necessary, when measuring the height of a ceiling, to make the measurement:

- from the floor to the underside of the ceiling lining; or
- if there is no ceiling lining, to the underside of the floor or roof above.

Exposed beams are permitted to encroach below the minimum ceiling height, but care should be taken to make sure that adequate height is still available.

In the case of stairs and ramps, the measurement is taken vertically from the nosing line of the stairway treads or the floor surface of the ramp, landing or the like, with no overhead projection encroachments permitted.

FV3.1 Room or space height

FV3.1 is a means to verify that the height of a habitable room or space is suitable for the intended use, and therefore meets the requirement of **FP3.1**.

Health and amenity

In relation to the intended function of a room or space, the activities that are likely to be undertaken by occupants in the room or space, as well as the features of the activities, are relevant considerations when determining a suitable height.

For example, if the intended use of a room is a gymnasium, then gymnastic activities are likely to be undertaken in the room. These activities often involve jumps and flips which require significant space in order to be undertaken safely.

In terms of the occupants, their features and needs are also relevant when determining a suitable height. For example, occupant features and needs would differ between rooms or spaces intended as a child's play area, and rooms or spaces intended for adult's indoor cricket.

The method requires the consideration of occupant characteristics and activity characteristics through the defined terms 'activity traits', 'occupant traits' and 'activity support level'. Refer to [Schedule 3](#) for more information on these terms.

When determining the activity support level, the method requires consideration of the relevant dimensions of items likely to be located in the room or space, as well as occupant circulation spaces.

Some of these considerations are explained below:

- Stairs and ramps, since the height of the room or the space will change relative to the occupant during incline and decline.
- Fixed fittings such as lights that may protrude from the ceiling and wash-basins.
- Fixed services such as air-conditioners, heaters, ceiling fans and heated water systems.
- Fixed equipment such as manufacturing or processing equipment, permanent signage or displays and lifts.
- Moveable equipment such as whitegoods.
- Fixed furniture such as built-in wardrobes and permanent seating.
- Moveable furniture such as wardrobes, desks and beds.
- Occupant circulation spaces so that occupants can move comfortably and safely around the room or space.

For example, the location and dimensions of a washbasin is a relevant consideration in determining the activity support level of a bathroom. This is because an occupant will typically need to access the washbasin whilst standing, which will influence the necessary height of the space.

Another example is the consideration of moveable equipment such as a refrigerator in a kitchen. If the intended use of the space is a kitchen, then it would be unrealistic to determine a sufficient height for the room without considering the height of a typical refrigerator that would be located in the room.

Part F3 Room heights

Deemed-to-Satisfy Provisions

F3.0 Deemed-to-Satisfy Provisions

Intent

To clarify that [FP3.1](#) will be achieved by compliance with [F3.1](#) and for farm sheds, [Part H3](#) if applicable.

F3.1 Height of rooms and other spaces

Intent

To establish a range of reasonable ceiling heights suitable for particular rooms and spaces.

2.4 metres

Generally, the minimum ceiling height has been set at 2.4 metres:

- [F3.1\(a\)\(iii\)](#) deals with habitable rooms (apart from kitchens) in Class 2 and Class 3 buildings and Class 4 parts;
- [F3.1\(b\)\(i\)](#) apart from some specified exceptions, in Class 5-8 buildings;
- [F3.1\(c\)\(i\)](#) and [\(iii\)](#) deals with Class 9a patient-care areas, treatment rooms, clinics, waiting rooms, passageways and corridors;
- [F3.1\(d\)\(i\)](#) is for school classrooms and smaller assembly buildings;
- [F3.1\(e\)\(ii\)](#) and [\(iii\)](#) deal with corridors, etc and habitable rooms (apart from kitchens) in Class 9c buildings; and
- [F3.1\(f\)\(ii\)](#) deals with commercial kitchens.

2.1 metres

A reduced height of 2.1 metres is permitted in areas unlikely to be occupied for long periods, where the reduction from 2.4 metres will not adversely affect occupant safety, health or amenity. Such areas include:

- kitchens or laundries or the like in Class 2 and Class 3 buildings and Class 4 parts;
- corridors and passageways or the like in Class 2 and Class 3 buildings and Class 4 parts;
- corridors and passageways or the like in Class 5-8 buildings; and
- various bathing facilities, small storage areas, airlocks, garages, carparking facilities, tearooms and the like, which are located in any building, other than accessible adult change facilities required to comply with [Specification F2.9](#).

2.0 metres

A reduced height of 2 metres is permitted above stairways and ramps as these areas are used for transient purposes and therefore a reduction from the required height in corridors and rooms (2.1 and 2.4 metres generally) will not adversely affect occupant safety, health or amenity.

Ceiling heights above 2.4 metres

Some specific use areas require a ceiling height greater than 2.4 metres in recognition of the activities or equipment likely to be used in those areas, such as:

- operating theatres or delivery rooms which require a ceiling height of three metres to accommodate special lighting fixtures, air monitoring equipment, and medical apparatus; and
- larger assembly buildings, including corridors where the corridor serves a building or part of a building that accommodates more than 100 persons.

Accessible adult change facilities required to comply with Specification F2.9

Unlike other sanitary compartments, where a ceiling height of 2.1 m is acceptable, accessible adult change facilities required to comply with [Specification F2.9](#) include a ceiling-mounted hoist. These hoists require 300 mm additional clearance to avoid the rails or hoist unit (other than the hook) impinging upon the headroom of users.

Measurement of height

When measuring the height of a room, allowance should be made for floor finishes such as tiles or carpet to ensure that the minimum ceiling height is achieved.

Part F4 Light and ventilation

Objective

FO4

The Objective of this Part is to—

- (a) safeguard occupants from injury, illness or loss of amenity due to—
 - (i) isolation from natural light; and
 - (ii) lack of adequate artificial lighting; and
- (b) safeguard occupants from illness or loss of amenity due to lack of air freshness.

Functional Statements

FF4.1

A space within a building used by occupants is to be provided with openings to admit natural light consistent with its function or use.

[FF4.1](#) requires that a building space must have openings providing enough natural light for a room to fulfil its purpose.

FF4.2

A space within a building used by occupants is to be provided with artificial lighting consistent with its function or use which, when activated in the absence of suitable natural light, will enable safe movement.

FF4.3

A space used by occupants within a building is to be provided with adequate ventilation consistent with its function or use.

[FF4.3](#) requires that a building space used by occupants must have ventilation that provides adequate air, so the room can fulfil its purpose. “Adequate air” includes both quantity and quality.

The building and its location may impose constraints on the quality of the ventilation air.

Example

A building’s location may impose constraints on the quality of the ventilation air such as when the building is in a central business district. Here, even locating intakes at the highest point on the building could still draw in significant quantities of vehicle exhaust fumes. The air may not be totally “fresh”. Nonetheless, efforts must be made to make sure the air is of adequate quality.

Ventilation standards are influenced by many factors, including:

- the number of people being provided with air;
- activities in the building which might lead to a build-up of toxic gases;
- climatic conditions; and
- the distribution of ventilation openings.

Some of the primary problems, which a ventilation system must attempt to overcome, include:

- excessive heat;
- excessive humidity; and
- offensive odours.

Performance Requirements

FP4.1 Natural lighting

[FP4.1](#) deals with natural light in Class 2, 3 or 9 building, or Class 4 parts of a building.

Health and amenity

FP4.1 nominates a minimum average daylight factor for rooms provided with natural light. Note that Verification Method **FV4.3** provides a method by which the average daylight factor may be calculated.

The level of natural light must be appropriate to the function of each part of the building (this differs from the **FP4.2** requirement for artificial light).

FP4.2 Artificial lighting

FP4.2 relates required lighting levels to the use of each part of the building. Unlike **FP4.1** with regard to natural light, **FP4.2** does not include the concept of even distribution.

The level of artificial light must be appropriate to the use of the building to enable safe movement by occupants (this differs from the **FP4.1** requirement for natural light). For example, in a movie theatre a lower level of lighting may be appropriate while a movie is being screened, however at the beginning and end of the movie when occupants are entering and exiting the theatre the minimum lighting level of 20 lux may be appropriate.

FP4.3 Outdoor air supply

FP4.3 requires a building's ventilation system to include for the supply of outdoor air.

FP4.4 Mechanical ventilation to control odours and contaminants

Where a mechanical air-handling system is installed, **FP4.4** requires it to achieve control with regard to the following:

- smells considered objectionable (including food, cooking and toilet odours); and
- the accumulation of germs, harmful microbes, other disease-causing agents, and poisons.

FP4.5 Disposal of contaminated air

FP4.5 requires that any contaminated air be disposed of so that it does not cause any nuisance or hazard to:

- occupants (of either the subject building, or any other building);
- people on neighbouring allotments; or
- people on a road.

Verification Methods

FV4.1 Verification of suitable indoor air quality

FV4.1 is a means of verifying if a proposed ventilation system for a Class 2, 3, 4, 6, 9b or 9c building achieves the minimum level of ventilation required by **FP4.3** and **FP4.4(a)**.

It is not compulsory for a designer to use **FV4.1**. The designer has the choice of using:

- **FV4.1** to verify that the proposal achieves **FP4.3** and **FP4.4(a)**;
- the Deemed-to-Satisfy Provisions of **F4.5** to **F4.9** and **F4.12**; or
- another means of verifying that **FP4.3** and **FP4.4(a)** will be achieved.

If **FV4.1** is used to verify compliance, it must be demonstrated that the building is sufficiently ventilated with outdoor air such that contaminant levels do not exceed the limits in **Table FV4.1**.

FV4.2 Verification of suitable indoor air quality for car parks

FV4.2 is a means of verifying if a proposed ventilation system for a Class 7a building achieves the minimum level of ventilation required by **FP4.3** and **FP4.4(a)**.

It is not compulsory for a designer to use **FV4.2**. The designer has the choice of using:

- **FV4.2** to verify that the proposal achieves **FP4.3** and **FP4.4(a)**;
- the Deemed-to-Satisfy Provisions of **F4.11**; or
- another means of verifying that **FP4.3** and **FP4.4(a)** will be achieved.

If **FV4.2** is used to verify compliance, it must be demonstrated that the building is sufficiently ventilated with outdoor air such that carbon monoxide exposure levels do not exceed the limits in **Table FV4.2**.

FV4.3 Verification of suitable provision of natural light

The average daylight factor (ADF) is used as the measure of the general illumination from outdoor natural light within a

Health and amenity

room. Where two or more windows in a room face different obstructions, or differ in transmittance, the ADF should be found separately for each window by adding the ADF for each window together to get the total ADF for the room.

W is the net area of the glazing panel (m²). This excludes the glazing frame and only includes the transparent or translucent elements.

A is the total area of the internal surfaces (m²). This includes the total area of the ceiling, floor and walls, including windows.

T is the diffuse light transmittance of the glazing. The measurement of light transmittance is specified in the Technical Protocols and Procedures Manual for Energy Rating of Fenestration Products of the Australian Fenestration Rating Council. Typical examples of light transmittance of glazing materials are given in the table below.

Typical light transmittance of glazing materials

Material	Diffuse light transmittance
Clear 6 mm glass	0.87
Tinted 6 mm glass (bronze)	0.50
Tinted 6 mm glass (grey)	0.44
Tinted 6 mm glass (green)	0.75
Strongly reflecting 6 mm glass	0.78
Double glazed unit (x2 6 mm clear glass)	0.76

θ is visible sky angle in degrees, measured in a vertical plane normal to the glass from the centre of the window (window reference point) as shown in the figure below. The determination of this angle should take into account objects such as shading projections, eaves, window reveals, fences, adjoining buildings, structures and the like.

Angle of visible sky

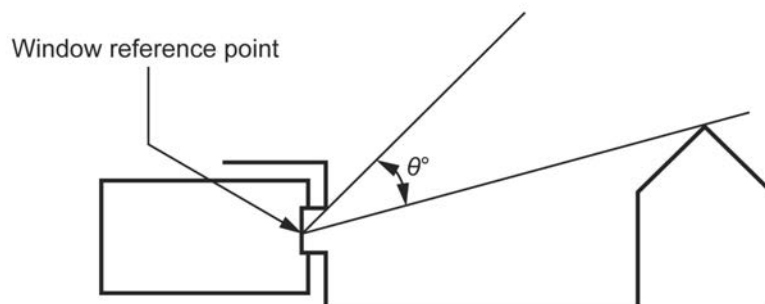

R is the area-weighted average reflectance area of the internal surfaces. Typical examples of reflectance of light values of materials are given below.

Typical reflectance of light values of materials

Material	Reflectance
Paving	0.20
Earth	0.20
Granite	0.20
Brickwork (red)	0.30
Concrete	0.40
Carpet (cream)	0.40
Carpet (deep colours)	0.10
Wood (unfinished pine)	0.20
Paint (white)	0.85
Paint (cream)	0.81
Paint (light grey)	0.68
Paint (mild grey)	0.45

Part F4 Light and ventilation

Deemed-to-Satisfy Provisions

F4.0 Deemed-to-Satisfy Provisions

Intent

To clarify that [Part F4](#), and [Parts G6](#) and [H3](#), if applicable, will satisfy the requirements of [FP4.1 - FP4.5](#).

Where a solution is proposed to comply with the Deemed-to-Satisfy Provisions, [F4.0](#) clarifies that compliance with [F4.1–F4.12](#), and [Parts G6](#) and [H3](#), if applicable, will achieve compliance with [FP4.1 - FP4.5](#).

Where a Performance Solution is proposed, the relevant Performance Requirements must be determined in accordance with [A2.2\(3\)](#) and [A2.4\(3\)](#) as applicable. (See commentary on [Part A2](#)).

F4.1 Provision of natural light

Intent

To specify the rooms in Classes of buildings where natural light is required.

See [FF4.1](#) and [FP4.1](#) for information on the reasons for the BCA natural light provisions.

The provision of natural light is substantially a health and amenity issue. It is considered of particular importance in all “living” and “sleeping” areas in residential buildings occupied by people for an extended period of time. The BCA consistently assumes that this is the case with Class 2 buildings and Class 4 parts, but not with Class 3 buildings.

Occupants of Class 3 and Class 9a buildings do not reside in the same building for an extended period of time. [F4.1](#) extends this assumption to the “living” areas (shared and unshared) of such buildings. For this reason, the BCA only requires the provision of natural light to sleeping areas in Class 3 and Class 9a buildings.

[F4.1\(b\)](#) assumes that in Class 3 buildings the occupants spend more time in their “sleeping” accommodation than they do in “living” areas. This is usually the case in Class 2 buildings and Class 4 parts.

[F4.1\(c\)](#), with regard to Class 9a and 9c buildings, takes account of the fact that occupants will generally be in their beds throughout the day and natural light will be important to them.

It is considered desirable that school and pre-school children are able to view the outside environment, and work or play using natural light. Accordingly, buildings such as kindergartens and schools must provide natural light to playrooms and classrooms.

F4.2 Methods and extent of natural light

Intent

To specify the requirements for the size and location of windows, including roof lights to provide required natural light.

A window includes roof lights, glassed louvres and glazed doors (see definition in [Schedule 3](#)).

[F4.2\(a\)\(i\)](#) sets out the requirement for natural light provided by windows other than roof lights. [F4.2\(a\)\(ii\)](#) sets out the requirement for natural light provided by roof lights.

A roof light generally receives greater exposure to sunlight than a window because of its orientation to the sky and consequently, the size of a roof light as a percentage of the floor area served is permitted to be smaller than for a window serving the same floor area.

To achieve the requirements for natural light when both windows and roof lights are provided, a proportional combination of [F4.2\(a\)\(i\)](#) and [\(ii\)](#) can be used through [F4.2\(a\)\(iii\)](#). This is explained in the following example.

Example

Health and amenity

Method for determining proportional combination of windows and roof lights.

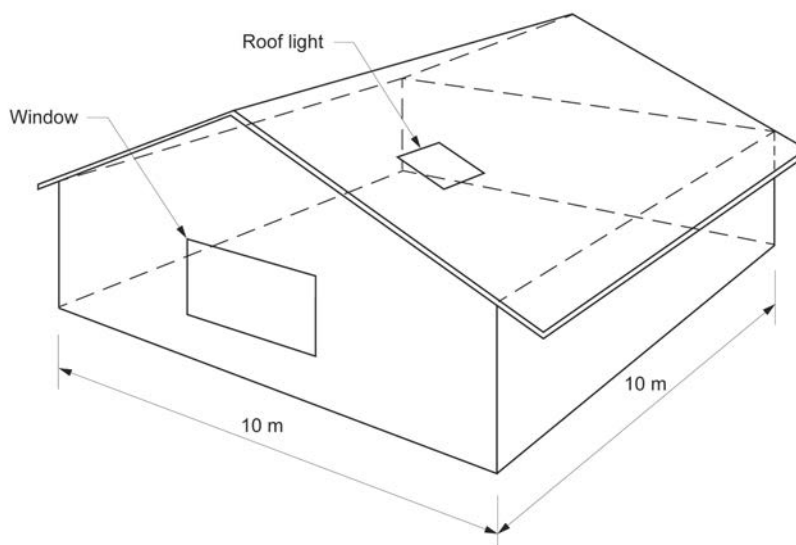
**Description of above diagram**

Area of the room which requires natural light is 100 m².

No natural light borrowed from adjoining rooms.

General requirements

Required windows to provide natural light must have a light transmitting area of at least 10% of the floor area.

$$10\% \text{ of } 100 \text{ m}^2 = 10 \text{ m}^2$$

Or, roof lights to provide natural light must have a light transmitting area of at least 3% of the floor area.

$$3\% \text{ of } 100 \text{ m}^2 = 3 \text{ m}^2$$

In the formula below, 3% of the floor area is expressed as the fraction 0.03 and 10% of the floor area is expressed as the fraction 0.1.

Calculations**Formula—for the area of window(s) required to compensate for roof light shortfall**

Area of room covered by the roof light = (Area of roof light) / 0.03

Required window(s) area = [(Floor area) – (Area covered by the roof light)] / 10

Area of windows required to compensate for roof light shortfall

If the roof light = 1 m²

Area of room covered by the roof light = (1 m² / 0.03) = 33.33 m²

Required window(s) area = (100 m² – 33.33 m²) / 10 = 6.67 m²

Formula—for the area of roof lights required to compensate for window(s) shortfall

Area of room covered by the window(s) = (Area of window(s)) / 0.1

Required roof light area = [(Floor area) – (Area covered by the window)] / 33.33

Area of roof lights required to compensate for window shortfall

If the window = 5 m²

Area of room covered by the window(s) = (5 m² / 0.1 m²) = 50 m²

Required roof lights area = (100 m² – 50 m²) / 33.33 m² = 1.5 m²

Notes:

1. For the purpose of this example a window excludes a roof light.
2. The same proportional calculation principle applies if—
 - a. two or more windows are used; or

Health and amenity

- b. two or more roof lights are used.

All windows, both required and non-required, must comply with the various requirements of the BCA's fire-safety provisions, such as [C3.2](#) for openings in external walls, and [Clause 3.6](#) of [Specification C1.1](#) for roof lights.

Figure F4.2(1) Elevation showing method of measuring distance of window from boundary

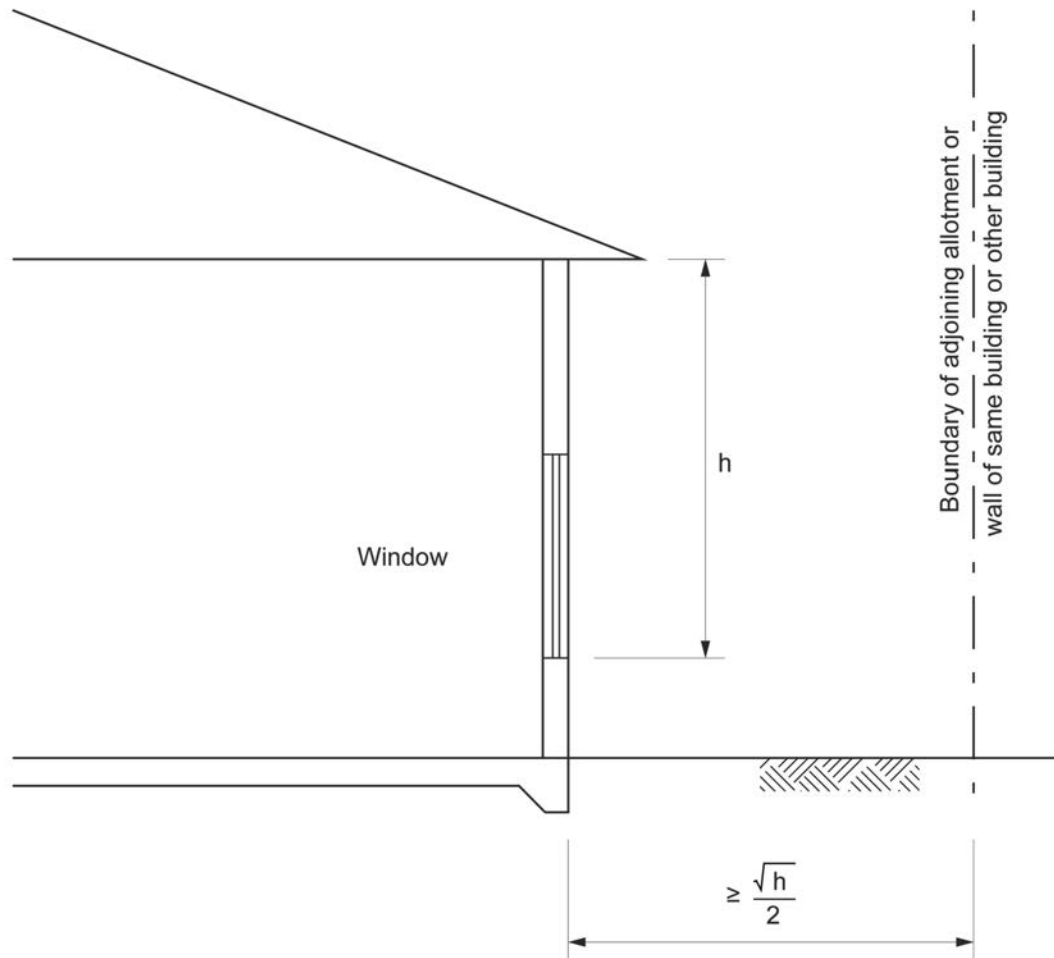

[F4.2\(b\)](#) does not prohibit windows closer to the boundary than one metre (or three metres in the case of a patient-care area in a Class 9a building). However, if a window is located within these distances, [F4.2\(b\)](#) does not allow it to be considered as providing required natural light to the subject room.

It should be noted that [F4.2\(b\)](#) does not apply to Class 9c buildings. [F4.2\(c\)](#) contains specific provisions for these buildings.

[Figure F4.2\(1\)](#) illustrates the method of measuring the distance of the window from:

- an adjoining allotment boundary;
- a wall of the same building; and
- a wall of another building on the same allotment.

[F4.2\(c\)](#) contains requirements for Class 9c buildings. The requirement for the window sill to be not more than 1 m above floor level and at least 3 m from an adjoining allotment, another building or wall is to maintain amenity for residents who spend a significant amount of time sitting on chairs or lying in bed. [Figure F4.2\(2\)](#) illustrates the method of measuring these distances.

Figure F4.2(2) Illustration of window sill in an aged care building

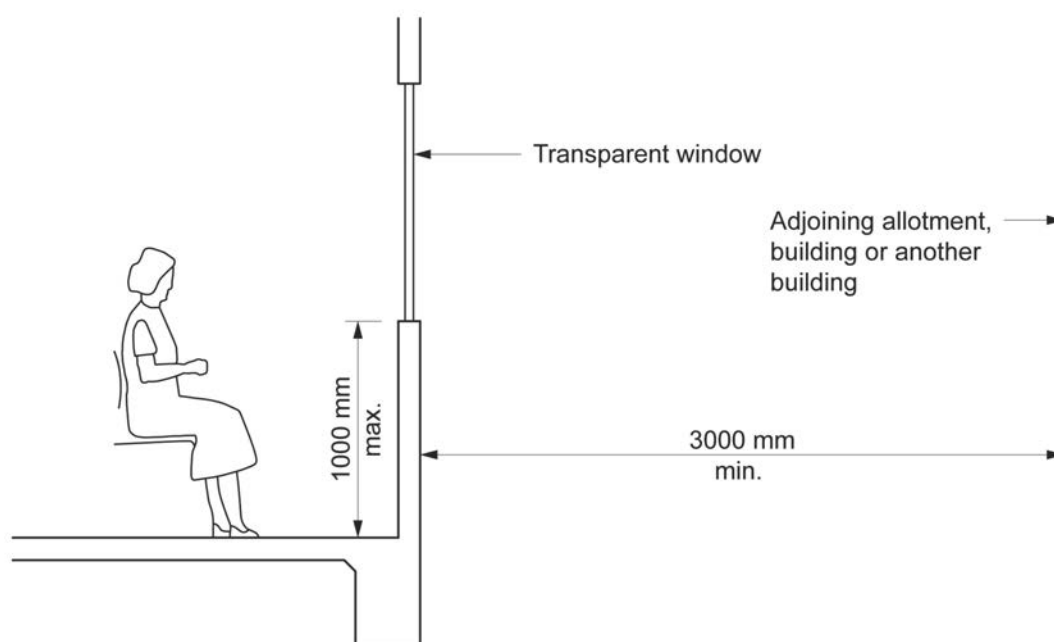

F4.2(d) contains requirements for Class 9b early childhood centres. The well-being of children in these types of buildings is enhanced through improved interaction with the outdoor environment by the provision of 50% of window sills in children's rooms required to be located not more than 500 mm above the floor level.

The following is not considered a children's room:

- a passageway or thoroughfare (including door swings);
- a toilet and hygiene facilities;
- a room permanently set aside for storage;
- a room for staff or administration;
- a kitchen, unless the use of the kitchen is part of an educational program provided by the service; or
- any other space that is not suitable for children.

F4.3 Natural light borrowed from adjoining room

Intent

To allow natural light to be "borrowed" from an adjoining room.

F4.3 applies only to a room in:

- a Class 2 building;
- a Class 4 part; or
- a sole-occupancy unit in a Class 3 building.

For these Classes, it is sometimes acceptable for a room's required natural light to be "borrowed" from an adjoining room (i.e. an adjoining room's light can be used to help make up the total amount of natural light required in the subject room).

The use of borrowed light is acceptable if the provisions of F4.3 are applied to the subject room and to the total area of each relevant room.

Any borrowed natural light must be from an adjoining room over which occupants of the subject room have some control. F4.3(a)(i) therefore requires that the adjoining room be within the same sole-occupancy unit or be an enclosed verandah on common property. As a consequence, the required natural light cannot be from another sole-occupancy unit.

Direct natural light provided from another source is intended to mean light from a window or roof light in the subject room. As the provision relates to natural light obtained from an adjoining room, 'another source' refers to direct natural light provided to the subject room which does not meet the required allowance of either 3% or 10% of the floor area for roof lights and windows respectively. By not meeting the required amount of natural light, the 'direct natural light from another

Health and amenity

source' can be used as a supplement to the natural light required from an adjoining room.

To borrow natural light from another room, [F4.3\(a\)\(ii\)](#) allows light to pass through glazed panels or openings from an adjoining room which, under [F4.3\(a\)\(iii\)](#), must have windows, roof lights or a combination of windows and roof lights of a minimum size in proportion to the combined floor areas of both rooms. The minimum size of the glazed panels or openings, and the minimum size of the windows to the adjoining room, are illustrated in [Figure F4.3](#).

If a doorway is used as an opening to obtain light from an adjoining room, any door is required to transmit natural light directly from outside a building to the room concerned when in the closed position (see [Figure F4.3](#)).

The area of openings needed to transmit natural light from an adjoining room may be reduced proportionally to the size of any openings in the subject room which transmit natural light directly from the outside.

Figure F4.3 Method for determining areas of openings for borrowed light

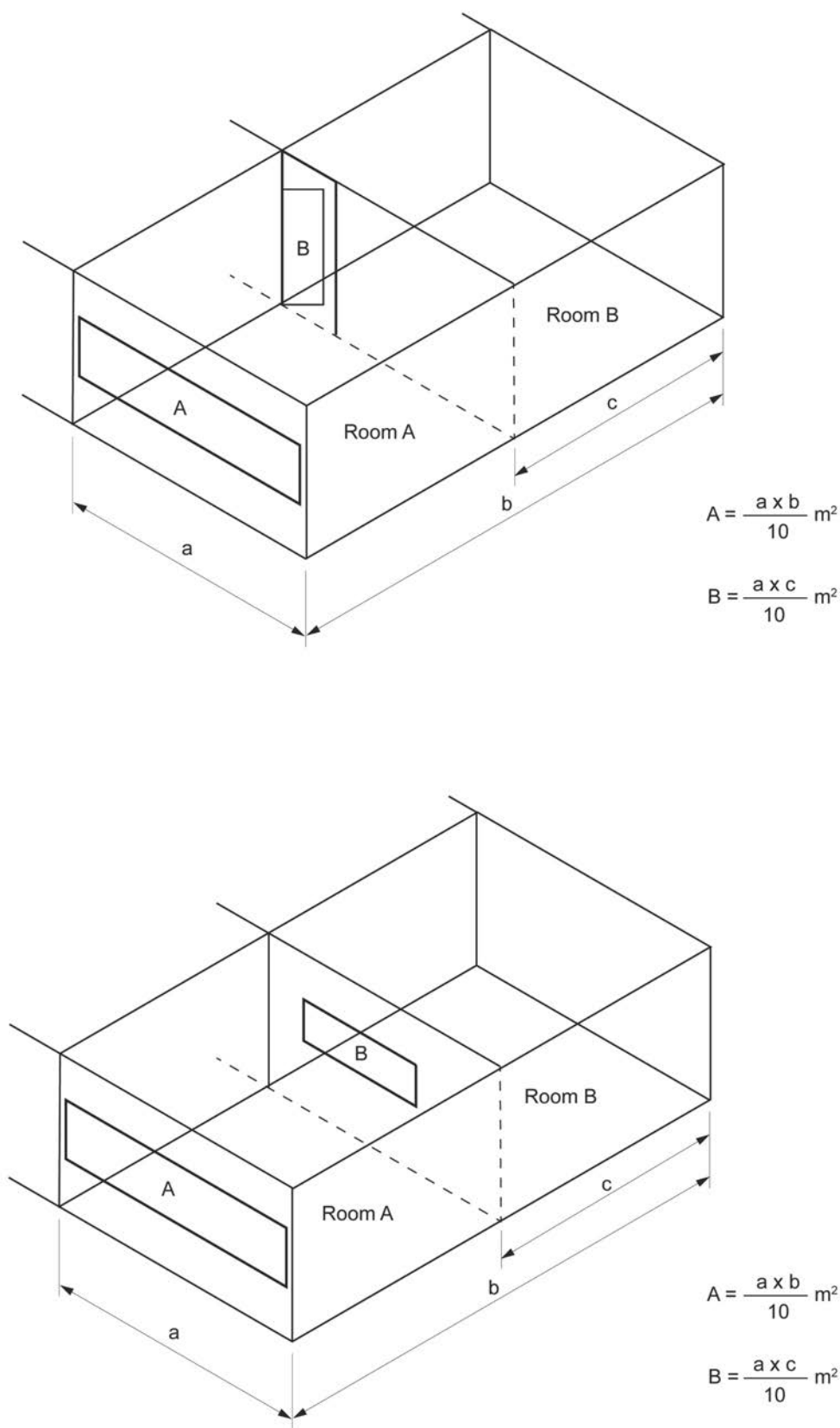

The same principle for Opening A in [Figure F4.3](#) can be applied for roof lights by substituting the required 10% opening in respect to the combined floor area with 3% of the combined floor area. It is also permitted to use a proportional combination of windows and roof lights. See the example in the comments on [F4.2](#) for an explanation.

F4.4 Artificial lighting

Intent

To specify the location and other requirements for required artificial lighting.

Artificial lighting is required where it is necessary to minimise any hazard to occupants during an emergency evacuation.

[F4.4\(a\)\(i\)](#) sets out those places where artificial lighting is always required. However, it does not require such lighting to be illuminated at all times.

[F4.4\(a\)\(ii\)](#) sets out those places where artificial lighting is required if the standard of natural light required by [F4.2](#) is unavailable, and the periods of occupation of the areas, or the use of the space, will create an undue hazard during an evacuation.

Determination of whether or not the periods of occupation of the specified areas will create an undue hazard during an evacuation is a judgement, which requires a “performance-type” assessment.

Class 4 parts of buildings are subject to [F4.4\(a\)\(ii\)](#) only with regard to wet areas and airlocks. (Any required stairways and the like in the rest of the building, which contains the Class 4 part, are required to be artificially lit under [F4.4\(a\)\(i\)](#)).

Class 2 buildings are subject to [F4.4\(a\)\(ii\)](#) with regard to wet areas, airlocks and any common areas such as stairways, etc used in common by occupants.

Class 3 and Class 5–9 buildings are subject to [F4.4\(a\)\(ii\)](#) with regard to all rooms frequently occupied, and all corridors, stairways and similar circulation routes and paths of egress. Unless they are “frequently occupied”, wet areas (including those in Class 3 buildings) are not subject to [F4.4\(a\)\(ii\)](#).

Apart from the “performance-type” judgement regarding the location of artificial lighting in those areas specified in [F4.4\(a\)\(ii\)](#), the remainder of the requirements are contained in the AS/NZS 1680.0 specified in [F4.4\(b\)](#).

[F4.4\(c\)](#) gives a concession for compliance with [F4.4\(a\)](#) in specific buildings which have lower levels of lighting as part of their normal operation. For example, the lighting levels specified in AS/NZS 1680.0 would be inappropriate during the screening of a movie in a cinema or may lead to damage of artworks in a gallery.

F4.5 Ventilation of rooms

Intent

To state the natural and mechanical ventilation requirements for rooms and buildings.

The specified rooms and buildings, and any other room occupied by a person for any purpose, must be provided with either:

- natural ventilation complying with [F4.6](#); or
- mechanical ventilation or an air-conditioning system that complies with both of the Standards referenced in [F4.5\(b\)](#).

If a room or building is served by a mechanical ventilation or air-conditioning system for heating or cooling purposes and the system does not provide ventilation in accordance with AS 1668.2, then the room or building must also be provided with natural ventilation complying with [F4.6](#). Natural ventilation would therefore need to be provided to rooms served by a typical domestic type wall mounted air-conditioning split system. In addition, [F4.5](#) does not preclude natural ventilation serving a room or building if it is also served by a mechanical ventilation or air-conditioning system compliant with AS 1668.2.

F4.6 Natural ventilation

Intent

To specify the requirements for the size and location of windows providing required natural ventilation.

[F4.6](#) requires that permanent openings, windows, doors or other openable means provide natural ventilation. It also deals with the size of such openings, and the locations to which such openings must open.

[F4.6\(a\)\(ii\)\(A\)](#) requires a judgement regarding what is “suitably sized”; and [F4.6\(a\)\(ii\)\(B\)](#) requires a judgement regarding what is “open”.

[F4.6](#) does not require any of the required natural ventilation to be “fixed ventilation” or “permanent openings” as against “devices which can be opened”. The building proponent can make the decision.

If the natural ventilation openings are used only for ventilation purposes, roller shutters and doors can cover the openings

Health and amenity

if they achieve the performance standard in [F4.6\(a\)](#). However, if the openings are also used for egress purposes, they must comply with the requirements of provisions such as [D2.19](#) and [D2.21](#).

Under [F4.6\(b\)](#), the option of using prescribed natural ventilation opening sizes for Class 8 electricity network substations is removed. The prescribed ventilation openings are not conducive to Class 8 electricity network substations as they may allow excessive dust, humidity and other weather conditions that are detrimental to the sensitive and hazardous equipment used in these buildings.

F4.7 Ventilation borrowed from adjoining room

Intent

To allow natural ventilation to be “borrowed” from adjoining rooms.

[F4.7\(a\)](#) applies only to:

- Class 2 buildings;
- Class 4 parts; and
- sole-occupancy units in Class 3 buildings.

Except for Class 8 electricity network substations, [F4.7\(b\)](#) applies only to Class 5–9 buildings.

It is sometimes acceptable for a room’s required natural ventilation to be “borrowed” from an adjoining room (i.e. an adjoining room’s ventilation can be used to help make up the total amount of ventilation required).

The use of borrowed ventilation is acceptable if the provisions of [F4.7](#) are applied to the subject room and to the total area of each relevant room.

Any borrowed natural ventilation to a room must be from a room over which the occupants have some control. [F4.7\(a\)](#) therefore requires that the adjoining room be:

- within the same sole-occupancy unit; or
- an enclosed verandah on common property.

In a Class 2 or Class 3 building or Class 4 part, this requirement means that the natural ventilation cannot be from another sole-occupancy unit.

[F4.7\(a\)](#) and [\(b\)](#) allows a window, an opening, a door, or the like, to be used to “borrow” ventilation air from an adjoining room. The minimum area required for ventilation in residential buildings is illustrated in [Figure F4.7](#).

In Class 5–9 buildings, the area of ventilation opening required under [F4.7\(b\)](#) is similar to that required for residential buildings, except that:

- the area of ventilation opening must be increased from 5% to 10%; and
- any part of the ventilation opening between the rooms more than 3.6 metres above the floor must not be included as part of the required ventilation area.

Under [F4.7\(c\)](#), the area of openings needed to transfer natural ventilation borrowed from an adjoining room may be reduced proportionally to the size of any window or other opening in the room which receives natural ventilation directly from the outside.

Figure F4.7 Method for determining areas of openings for borrowed ventilation

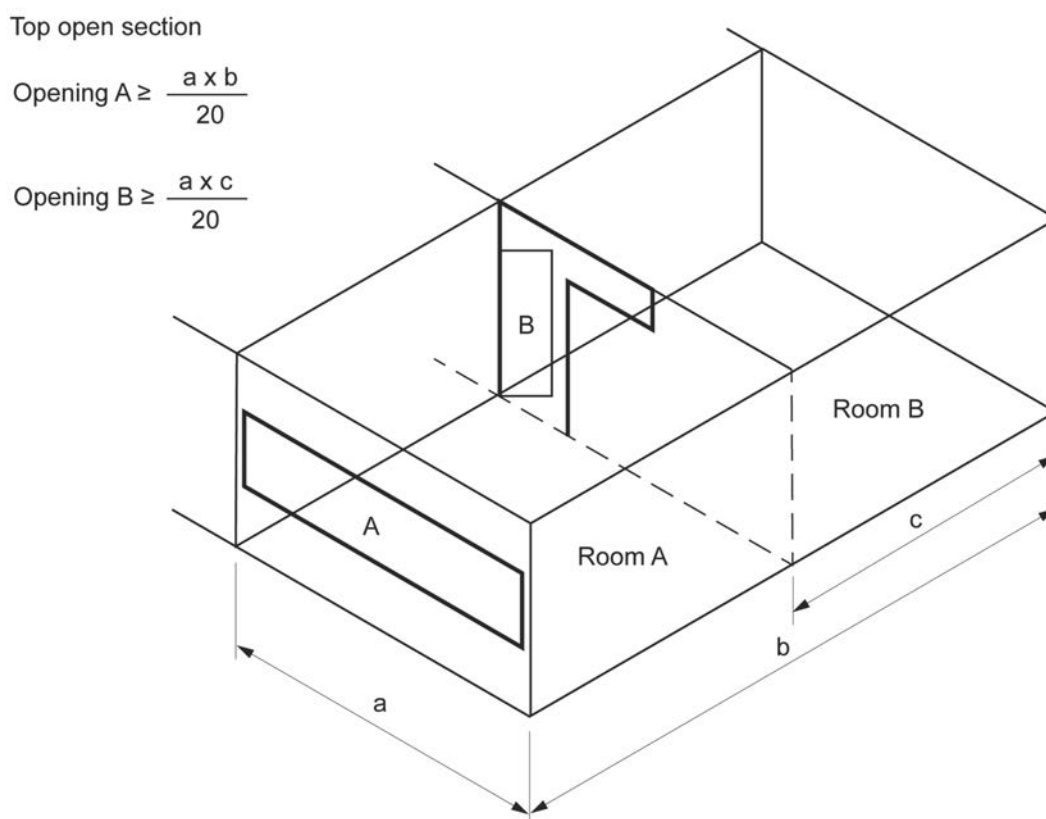

F4.8 Restriction on location of sanitary compartments

Intent

To minimise the impact of unpleasant smells.

While F4.8 prohibits toilets opening directly into specified areas, F4.9 sets out how toilets can serve those areas by using:

- airlocks or airlock equivalents; or
- mechanical exhaust ventilation and, in some cases, screening.

The odours from toilets can be unpleasant and so it is desirable to minimise their impact on adjacent areas such as:

- a kitchen or pantry;
- public-eating areas, but not domestic-eating areas (other than kitchens);
- Class 3 building dormitories (but no other sleeping areas);
- some assembly buildings (but not kindergartens, primary schools or open spectator stands); and
- most workplaces.

The exclusions include sleeping areas other than Class 3 dormitories. In houses, flats, motels and hotels the odours are usually generated by the resident/s, whereas, in a dormitory there is a high likelihood that:

- the odours are generated by unrelated people;
- the toilet-use ratio is higher; and
- there could also be a privacy issue.

Some other exclusions include kindergartens because staff need to keep children under continuous observation and open spectator stands because these are generally open to the air and therefore inherently well ventilated.

F4.9 Airlocks

Intent

To specify requirements for airlocks or mechanical ventilation where toilets open directly into other rooms.

While [F4.8](#) prohibits toilets opening directly into specified areas, [F4.9](#) sets out how toilets can serve those areas by using:

- airlocks or airlock equivalents; or
- mechanical exhaust ventilation and, in some cases, screening.

It is desirable to minimise toilet odours in particular areas. See [F4.8](#) and [F4.9](#) for airlock and mechanical exhaust ventilation where a builder wishes to locate a toilet close to, or open directly into, the areas specified in [F4.8](#).

F4.10 * * * * *

The content of [F4.10](#), which existed in BCA 1990, has been relocated to [F1.12](#). The Clause number [F4.10](#) has been retained without text so as not to change the numbering of the current BCA from that of BCA 1990.

F4.11 Carparks

Intent

To specify ventilation requirements for carparks, to ensure car fumes are adequately removed.

[F4.11](#) does not apply to an open-deck carpark because such carparks are provided with adequate, permanent, natural ventilation.

AS 1668.2 contains mechanical ventilation requirements for the Deemed-to-Satisfy Provisions.

F4.12 Kitchen local exhaust ventilation

Intent

To minimise the spread of cooking odours and fire from commercial kitchens.

The aim of [F4.12](#) is to:

- reduce the prevalence of airborne fats, etc building up, and causing health and fire problems;
- reduce steam and smoke from cooking processes; and
- maintain the flow of air to reduce potentially obnoxious odours.

The figures in [F4.12\(a\)](#) relate to the size of any electrical or gas cooking apparatus, which may cause these problems.

The figures in [F4.12\(b\)](#) relate to the ratio of electrical or gas cooking apparatuses to room size, which may cause these problems.

The Deemed-to-Satisfy Provisions require exhaust hoods to comply with both AS 1668.1 and AS 1668.2.

Part F5 Sound transmission and insulation

Objective

FO5

The Objective of this Part is to safeguard occupants from illness or loss of amenity as a result of undue sound being transmitted—

- (a) between adjoining sole-occupancy units; and
- (b) from common spaces to sole-occupancy units; and
- (c) from parts of different classifications to sole-occupancy units.

Application:

FO5 only applies to a Class 2 or 3 building or a Class 9c building.

Part **F5** addresses sound and its impact on health and amenity, but only within a Class 2, Class 3 and Class 9c buildings. Reasons why it does not cover sound emanating from outside the building include:

- builders, etc have little control over external sound, which is usually intermittent during daylight hours when the background ambience sound within the building is greater; and
- sound generated within a building is more likely to pass through walls and fittings, and cannot be controlled by simply closing a window. Such sounds can be more intrusive and disruptive to occupants.

Functional Statements

FF5.1

A part of a building that separates—

- (a) sole-occupancy units; or
- (b) a sole-occupancy unit from a part of another classification in the building; or
- (c) a sole-occupancy unit from a common space,

is to be constructed to prevent undue sound transmission.

Application:

FF5.1 only applies to a Class 2 or 3 building or a Class 9c building.

To achieve **FO5** in a Class 2, Class 3 and Class 9c buildings, sound transmission must be minimised through a building element that separates:

- sole-occupancy units;
- a sole-occupancy unit and a common space; or
- a sole-occupancy unit from parts of the building with a different classification.

Because of its emphasis on building elements which separate sole-occupancy units and sole-occupancy units and common spaces and parts of the building with a different classification, **FF5.1** does not cover building elements which separate sole-occupancy units from the outside of a building, and therefore does not cover:

- sound generated outside a building; or
- sound escaping from a building and re-entering via an external element.

Performance Requirements

FP5.1 Sound transmission through floors

FP5.1 applies to Class 2 and 3 buildings and relates to the floor between sole-occupancy units, sole-occupancy units and specified spaces, and sole-occupancy units and parts of a different classification. It covers both airborne and impact generated sound. **FP5.1** covers sound transmission through floors from a number of specified spaces. A list is included

Health and amenity

with the additional words 'or the like'. An example of a floor separating sole-occupancy units from parts of a different classification, would be a floor separating ground floor shops from an apartment level above.

FP5.2 Sound transmission through walls

FP5.2 applies to Class 2 and 3 buildings and relates to the walls between sole-occupancy units, sole-occupancy units and specified spaces, and sole-occupancy units and parts of a different classification. It covers both airborne and impact generated sound. FP5.2(b) covers sound transmission through walls from a number of specified spaces. A list is included with the additional words 'or the like'. An example of a wall separating sole-occupancy units from parts of a different classification, would be a wall in a building between shops and hotel rooms.

Unlike FP5.1, impact generated sound is only a consideration for walls separating a bathroom, kitchen, sanitary compartment or laundry in one sole-occupancy unit from a habitable room (other than a kitchen) in an adjoining unit.

FP5.3 Sound transmission through floor and wall penetrations and door assemblies

FP5.3 supports the requirements of FP5.1 and FP5.2 in that the performance of building elements in Class 2 and Class 3 buildings are not to be compromised because of services that penetrate the elements.

Examples

Sounds prohibited under FP5.3 include those from a service pipe in the form of:

- pump vibration;
- water hammer; or
- sewerage or sullage discharging in soil or waste pipes.

FP5.4 Sound transmission through floors in residential care buildings

FP5.4 relates to floors between sole-occupancy units in Class 9c buildings. It covers airborne and impact-generated sounds between units located above one another. It does not cover sound transmission through floors from common spaces, such as a common corridor, laundry or entertainment area.

FP5.5 Sound transmission through walls in residential care buildings

FP5.5 only applies to Class 9c buildings.

For airborne sound, FP5.5 relates to the insulation of walls:

- between sole-occupancy units; and
- between sole-occupancy units and a kitchen, bathroom, sanitary compartment (not being an associated ensuite), laundry, plant room or utilities room.

For impact generated sound, FP5.5 relates to the insulation of walls between sole-occupancy units and a kitchen or laundry.

FP5.6 Sound transmission through floor and wall penetrations in residential care buildings

FP5.6 supports the requirements of FP5.4 and FP5.5 in that the performance of building elements in Class 9c buildings are not to be compromised because of services that penetrate the elements.

Examples

Sounds prohibited under FP5.6 include those from a service pipe in the form of:

- pump vibration;
- water hammer; or
- sewerage or sullage discharging in soil or waste pipes.

Verification Methods

FV5.1 Sound transmission through floors [FP5.1 and FP5.3]

FV5.1 is a means of verifying whether a floor achieves the requirements of FP5.1 and FP5.3 in minimising the transmission of airborne and impact generated sound through the floor. It only applies to Class 2 and 3 buildings.

It is not compulsory for a designer to use FV5.1. The designer has the choice of using:

- FV5.1 to verify that a proposal achieves FP5.1 and FP5.3;

Health and amenity

- the Deemed-to-Satisfy Provisions of [Part F5](#); or
- another means of verifying that [FP5.1](#) and [FP5.3](#) will be achieved.

If FV5.1 is used to verify compliance, when tested on site the floor must have a weighted standardised level difference with spectrum adaptation term ($D_{nT,w} + C_{tr}$) not less than 45, and a weighted standardised impact sound pressure level with spectrum adaptation term ($L_{nT,w}$) not more than 62.

$D_{nT,w}$ is a measure of airborne sound insulation, similar to R_w . C_{tr} is a spectrum adjustment factor which adjusts for low frequency sound levels. C_{tr} has been chosen in recognition of the problems caused by the high bass frequency outputs of modern home theatre systems and music reproduction equipment used by occupants of Class 2 and 3 buildings.

The $D_{nT,w}$ and C_{tr} must be determined in accordance with AS/NZS ISO 717.1. AS/NZS ISO 717.1 outlines how to use test results to determine the $D_{nT,w}$ and C_{tr} of a building element. The test results must be obtained by testing the floor in accordance with ISO 140-4. ISO 140-4 is the method for testing the airborne sound insulation of building elements in the field.

$L_{nT,w}$ is a measure of impact sound insulation. The lower the $L_{nT,w}$, the better the floor's impact sound insulation rating.

The $L_{nT,w}$ must be determined in accordance with AS ISO 717.2. This document outlines how to use test results to determine the $L_{nT,w}$ and C_l of a building element. The test results must be obtained by testing the floor in accordance with ISO 140-7. ISO 140-7 is the method for testing the impact sound insulation of building elements in the field.

FV5.2 Sound transmission through walls [FP5.2(a) and FP5.3]

FV5.2 is a means for verifying if a wall complies with the requirements of [FP5.2\(a\)](#) and [FP5.3](#) in minimising the transmission of airborne sound through the wall. As with [FV5.1](#) it only applies to Class 2 and 3 buildings.

It is not compulsory for a designer to use [FV5.2](#). The designer has the choice of using:

- [FV5.2](#) to verify that a proposal achieves [FP5.2\(a\)](#) and [FP5.3](#);
- the Deemed-to-Satisfy Provisions of [Part F5](#); or
- another means of verifying that [FP5.2\(a\)](#) and [FP5.3](#) will be achieved.

If [FV5.2](#) is used to verify compliance, when tested on site the wall must have a weighted standardised level difference with spectrum adaptation term ($D_{nT,w} + C_{tr}$) not less than 45.

$D_{nT,w}$ is a measure of airborne sound insulation, similar to R_w . C_{tr} is a spectrum adjustment factor which adjusts for low frequency sound levels. C_{tr} has been chosen in recognition of the problems caused by the high bass frequency outputs of modern home theatre systems and music reproduction equipment used by occupants of Class 2 and 3 buildings.

The $D_{nT,w}$ and C_{tr} must be determined in accordance with AS/NZS ISO 717.1. AS/NZS ISO 717.1 outlines how to use test results to determine the $D_{nT,w}$ and C_{tr} of a building element. The test results must be obtained by testing the wall in accordance with ISO 140-4. ISO 140-4 is the method for testing the airborne sound insulation of building elements in the field.

Unlike [FV5.1](#), the requirements differ depending on the location of the wall. Walls separating sole-occupancy units require a $D_{nT,w} + C_{tr}$ not less than 45. Walls separating sole-occupancy units and areas such as plant rooms, lift shafts, stairways, public corridors, public lobbies or the like, or parts of a different classification, must have a $D_{nT,w}$ not less than 45. C_{tr} does not apply in these instances, as the walls separate units from areas that are not likely to produce low frequency noise, which C_{tr} accounts for.

Door assemblies are permitted in walls between sole-occupancy units and public corridors, stairways or the like, providing the door assembly has a $D_{nT,w}$ not less than 25. Door assemblies are also permitted in walls between sole occupancy units, providing the door assembly has the same level of sound insulation as the wall i.e. $D_{nT,w} + C_{tr}$ not less than 45.

There is no verification method for determining compliance with [FP5.2\(b\)](#). [FP5.2\(b\)](#) outlines the impact generated sound insulation requirements for walls. Therefore, in this instance the options for compliance are:

- the Deemed-to-Satisfy Provisions of [Part F5](#) i.e. discontinuous construction; or
- another means of verifying that [FP5.2\(b\)](#) will be achieved.

FV5.3 Sound transmission through floors [FP5.4 and FP5.6]

FV5.3 is a means of verifying whether a floor achieves the requirements of [FP5.4](#) and [FP5.6](#) in minimising the transmission of airborne and impact generated sound through the floor. It only applies to Class 9c buildings.

It is not compulsory for a designer to use [FV5.3](#). The designer has the choice of using:

- [FV5.3](#) to verify that a proposal achieves [FP5.4](#) and [FP5.6](#);
- the Deemed-to-Satisfy Provisions of [Part F5](#); or

- another means of verifying that [FP5.4](#) and [FP5.6](#) will be achieved.

If [FV5.3](#) is used to verify compliance, when tested on site the floor must have a weighted standardised level difference ($D_{nT,w}$) not less than 40, and a weighted standardised impact sound pressure level ($L_{nT,w}$) not more than 62.

$D_{nT,w}$ is a measure of airborne sound insulation, similar to R_w .

The $D_{nT,w}$ must be determined in accordance with AS/NZS ISO 717.1. AS/NZS ISO 717.1 outlines how to use test results to determine the $D_{nT,w}$ of a building element. The test results must be obtained by testing the floor in accordance with ISO 140-4. ISO 140-4 is the method for testing the airborne sound insulation of building elements in the field.

$L_{nT,w}$ is a measure of impact sound insulation. The lower the $L_{nT,w}$, the better the floor's impact sound insulation rating.

The $L_{nT,w}$ must be determined in accordance with AS ISO 717.2. This document outlines how to use test results to determine the $L_{nT,w}$ of a building element. The test results must be obtained by testing of the floor in accordance with ISO 140-7. ISO 140-7 is the method for testing the impact sound insulation of building elements in the field.

FV5.4 Sound transmission through walls [FP5.5(a) and FP5.6]

[FV5.4](#) is a means for verifying if a wall complies with the requirements of [FP5.5\(a\)](#) and [FP5.6](#) in minimising the transmission of airborne sound through the wall. It only applies to Class 9c buildings.

It is not compulsory for a designer to use [FV5.4](#). The designer has the choice of using:

- [FV5.4](#) to verify that a proposal achieves [FP5.5\(a\)](#) and [FP5.6](#);
- the Deemed-to-Satisfy Provisions of [Part F5](#); or
- another means of verifying that [FP5.5\(a\)](#) and [FP5.6](#) will be achieved.

If [FV5.4](#) is used to verify compliance, when tested on site the wall must have a weighted standardised level difference with spectrum adaptation term ($D_{nT,w}$) not less than 40.

$D_{nT,w}$ is a measure of airborne sound insulation, similar to R_w .

The $D_{nT,w}$ must be determined in accordance with AS/NZS ISO 717.1. AS/NZS ISO 717.1 outlines how to use test results to determine the $D_{nT,w}$ of a building element. The test results must be obtained by testing the wall in accordance with ISO 140-4. ISO 140-4 is the method for testing the airborne sound insulation of building elements in the field.

Walls separating sole-occupancy units require a $D_{nT,w}$ not less than 40. Walls separating sole-occupancy units and areas such as plant rooms, lift shafts, stairways, public corridors, public lobbies or the like, or parts of a different classification, must also have a $D_{nT,w}$ not less than 40.

There is no Verification Method for determining compliance with [FP5.5\(b\)](#). [FP5.5\(b\)](#) outlines the impact generated sound insulation requirements for walls. Therefore, in this instance the options for compliance are:

- the Deemed-to-Satisfy Provisions of [Part F5](#) i.e. discontinuous construction; or
- another means of verifying that [FP5.5\(b\)](#) will be achieved.

Part F5 Sound transmission and insulation

Deemed-to-Satisfy Provisions

F5.0 Deemed-to-Satisfy Provisions

Intent

To clarify that the requirements of [FP5.1–FP5.6](#) will be satisfied if compliance is achieved with [F5.1–F5.7](#).

F5.1 Application of Part

Intent

To clarify that [Part F5](#) only applies to Class 2, Class 3 and Class 9c buildings.

F5.2 Determination of airborne sound insulation ratings

Intent

To clarify the means of determining the airborne sound insulation rating (R_w , $R_w + C_{tr}$).

Throughout the [Part F5](#) Deemed-to-Satisfy Provisions, some forms of construction are required to have an R_w or $R_w + C_{tr}$. R_w and C_{tr} must be:

- determined under AS/NZS ISO 717.1 using laboratory measurements; or
- in compliance with [Specification F5.2](#).

R_w is a measure of airborne sound insulation. C_{tr} is a spectrum adjustment factor which adjusts for low frequency sound levels. C_{tr} has been chosen in recognition of the problems caused by the high bass frequency outputs of modern home theatre systems and music reproduction equipment used by occupants of Class 2 and 3 buildings.

The R_w and C_{tr} must be determined in accordance with either AS/NZS ISO 717.1. These documents outline how to use test results from testing a building element to determine the R_w and C_{tr} of the building element. The test results must be obtained by testing the building element in accordance with ISO 140-3. ISO 140-3 is the method for testing the airborne sound insulation of building elements in the laboratory.

This part previously referenced Sound Transmission Class (STC) ratings as a measure of sound insulation. The STC rating has been replaced by R_w and $R_w + C_{tr}$. A note contained in [Schedule 4](#) under AS/NZS ISO 717.1 states that materials tested in accordance with the previous Standard AS 1276 – 1979 must be considered equivalent to R_w values. These tests are only valid if they were issued prior to AS/NZS 1276.1 – 1999 being referenced in the BCA.

F5.3 Determination of impact sound insulation ratings

Intent

To clarify the means of determining the impact sound insulation ratings.

In [F5.4\(a\)](#) floors separating certain areas are required to have an $L_{n,w}$. [F5.3\(a\)](#) outlines that the $L_{n,w}$ must be:

- determined under AS ISO 717.2 using laboratory measurements; or
- in compliance with [Specification F5.2](#).

$L_{n,w}$ is a measure of impact sound insulation. The types of impact generated noise passing through floors that the requirements are aimed at minimising are noise associated with footsteps and moving of furniture.

[F5.3\(b\)\(i\)](#) requires walls of Class 2 and 3 buildings required to have an impact sound insulation rating to be of discontinuous construction. This term is defined in [F5.3\(c\)](#) and applies to all of [Part F5](#) including [Specifications F5.2](#) and [F5.5](#).

[F5.3\(b\)\(ii\)](#) requires walls of a Class 9c building required to have an impact sound insulation rating to:

- for other than masonry, consist of at least two separate leaves that do not have any rigid mechanical connection except at the periphery. (The reason for not allowing rigid connection is to reduce the transmission of impact sound to the sleeping area); or

Health and amenity

- be identical with a prototype having at least the same resistance to impact sound as a wall complying with [Table 2 of Specification F5.2](#).

[F5.3\(c\)](#) sets out a definition of discontinuous construction. The definition applies to the whole of [Part F5](#) (including [Specifications F5.2](#) and [F5.5](#)) and is a wall having a cavity of at least 20 mm between 2 leaves, and:

- for masonry, only be connected with resilient wall ties (these are a particular type of wall tie and are sometimes referred to as acoustic wall ties); and
- for other than masonry, other than at the periphery, have no mechanical linkage between the leaves. This means that a staggered stud wall is not deemed to be discontinuous construction.

F5.4 Sound insulation rating of floors

Intent

To minimise the transmission of sound through floors separating sole-occupancy units, and floors separating sole-occupancy units and certain types of space.

[F5.4](#) contains requirements for Class 2, 3 and 9c buildings.

For Class 2 and 3 buildings, a floor requires both airborne ($R_w + C_{tr}$) and impact sound insulation ($L_{n,w}$) if it separates:

- sole-occupancy units;
- a sole-occupancy unit from a plant room, lift shaft, stairway, public corridor, public lobby or the like; or
- parts of a different classification.

For Class 9c buildings, a floor requires airborne sound insulation if it separates sole-occupancy units.

The requirements differ between Class 2 and 3 buildings, and Class 9c buildings. This is due to sole-occupancy units in Class 2 and 3 buildings being 'noisier' than sole-occupancy units in Class 9c buildings. The reasons include the presence of televisions, stereos and DVDs and activities that may be conducted in Class 2 and 3 buildings. Therefore, C_{tr} and impact sound insulation only apply to Class 2 and 3 buildings. Also, the level of airborne sound insulation required in Class 9c buildings is less.

F5.5 Sound insulation rating of walls

Intent

To minimise the transmission of sound through walls separating sole-occupancy units and walls separating sole-occupancy units and certain types of spaces.

[F5.5\(a\)](#) and [\(b\)](#) apply to Class 2 and 3 buildings. [F5.5\(a\)](#) covers walls separating sole-occupancy units, and walls separating sole-occupancy units and certain spaces. [F5.5\(b\)](#) applies to a door assembly in a wall that separates a sole-occupancy unit from a common area. [F5.5\(c\)](#) and [\(d\)](#) apply to Class 9c buildings. [F5.5\(c\)](#) applies to walls which separate sole-occupancy units and sole-occupancy from certain spaces. [F5.5\(d\)](#) applies to a wall that separates a sole-occupancy unit from a kitchen or laundry. [F5.5\(e\)](#) and [\(f\)](#) contains additional requirements for sound insulated walls.

As with the requirements for floors, the requirements for walls differ between Class 2 and 3 buildings, and Class 9c buildings. This is due to sole-occupancy units in Class 2 and 3 buildings being 'noisier' than sole-occupancy units in Class 9c buildings. The reasons include the presence of televisions, stereos and DVDs and activities that may be conducted in Class 2 and 3 buildings. Therefore, C_{tr} only applies to Class 2 and 3 buildings. Also, the level of airborne sound insulation required in Class 9c buildings is less.

[F5.5\(a\)](#) outlines airborne and impact sound insulation requirements for walls. The airborne sound requirements apply to walls separating sole-occupancy units and a sole-occupancy unit from a plant room, lift shaft, stairway, public corridor, public lobby or the like, or parts of a different classification. For walls separating sole-occupancy units, the wall must have a $R_w + C_{tr}$ not less than 50. For walls separating a sole-occupancy unit from a plant room, lift shaft, stairway, public corridor, public lobby or the like, or parts of a different classification, the wall must have a R_w not less than 50. For walls separating habitable areas (excluding a kitchen) in one sole-occupancy unit from a bathroom, laundry, kitchen or sanitary compartment in an adjoining unit, the wall must be discontinuous construction. For the purpose of the BCA, discontinuous construction is a wall having a minimum 20 mm cavity between 2 separate leaves, with:

- for masonry, where wall ties are required to connect leaves, the ties are of the resilient type; and
- for other than masonry, there is no mechanical linkage between leaves, except at the periphery.

Mechanical linkage at the periphery is referring to the connection of the wall to the floor/roof and adjoining walls such as an external wall etc. A staggered stud wall with common top/bottom plates is not considered to be discontinuous

Health and amenity

construction.

F5.5(b) provides a concession for a door assembly located in a wall that separates a sole-occupancy unit from public corridor or the like. The door requires an R_w of not less than 30 whereas the wall requires R_w of not less than 45. This concession does not apply to a door assembly in a wall separating sole-occupancy units. In this case the door assembly would need to meet the same requirements for the wall, i.e. $R_w + C_{tr}$ 50.

F5.5(c) applies to Class 9c buildings and covers sound transmission through sole-occupancy units from certain adjoining rooms and spaces. The list of adjoining rooms and spaces does not include the words 'or the like' because it is intended to be specific to only those areas.

The list of other spaces in **F5.5(c)** does not include stairways, public corridors, hallways, etc. The reason is that aged care buildings are to be provided with a level of sound insulation around the resident bedroom/sleeping areas to ensure a level of privacy, but still allow the residents to be reassured they are not alone. If the R_w of the wall is too high it may create a feeling of isolation for the residents and this can be detrimental to their well-being. Being able to hear sounds that are outside their bedroom provides reassurance that assistance is available. The walls of sole-occupancy units prescribed in **F5.5(c)** must be at least R_w 45.

F5.5(d) applies to Class 9c buildings and deals with reducing the level of impact sound through the walls of the sole-occupancy units from adjoining kitchens and laundries. To comply with **F5.5(d)**, it is necessary for the wall to have an R_w not less than 45 (as required by **F5.5(c)**) and:

- for other than masonry, consist of at least two separate leaves that do not have any rigid mechanical connection except at the periphery. (The reason for not allowing rigid connection is to reduce the transmission of impact sound to the sleeping area); or
- be identical with a prototype having at least the same resistance to impact sound as a wall complying with [Table 2 of Specification F5.2](#).

F5.5(e) and **(f)** requires sound insulated walls to extend to either the roof/floor above or a ceiling that provides the required level of sound insulation. This is to ensure that there is no space above the wall which provide a flanking path for sound to travel through.

F5.6 Services

Intent

To minimise the transmission of sound that may arise from services that pass through more than one sole-occupancy unit.

F5.6 details separation requirements for services. The requirements only apply to services which pass through more than one sole-occupancy unit or are located in a wall or floor cavity which separates sole-occupancy units. **F5.6** does not apply if the pipe is only located in a single unit, or any part of a Class 2, 3 or 9c building which is not part of a sole-occupancy unit.

The $R_w + C_{tr}$ values do not take account of the inherent acoustic properties of a pipe material.

F5.7 Isolation of pumps

Intent

To minimise transmission of sound from a pump.

F5.7 requires flexible couplings at connection points to or from a pump to minimise vibration and any consequent sound transmission along the piping.

Specification F5.2

Sound insulation for building elements

Deemed-to-Satisfy Provisions

[Specification F5.2](#) (in conjunction with [Table 2 of Specification F5.2](#)) gives information on the weighted sound reduction index (R_w), weighted sound reduction index with spectrum adaptation term ($R_w + C_{tr}$) and weighted normalised impact sound pressure level with spectrum adaptation term ($L_{n,w}$) for some common forms of building construction. It also list examples of discontinuous construction.

Further information can be obtained through literature produced by building product manufacturers.

Specification F5.5**Impact sound—Test of equivalence****Deemed-to-Satisfy Provisions**

[Specification F5.5](#) contains details of the test procedure to determine how a proposed wall system resists the transmission of impact sound, in comparison to a system in [Table 2 of Specification F5.2](#).

[Clause 2](#) outlines the construction to be tested, and only requires that the [Table 2 of Specification F5.2](#) system being used as a test comparison is tested once, so long as certain specified conditions are followed.

[Clause 3](#) outlines the precise method to determine how a proposed wall system resists the transmission of impact sound, in comparison to a system included in [Table 2 of Specification F5.2](#). Several referenced documents are used as the basis of the testing procedure.

Part F6 Condensation management

Objectives

FO6 Condensation

The Objective of this Part is to safeguard occupants from illness or loss of amenity as a result of excessive internal moisture.

Application:

FO6 only applies to a Class 2 building or Class 4 part of a building.

Part F6 aims to limit the amount of condensation that can accumulate within a building by requiring that water vapour be extracted to a point external to the building. It only applies to residential building classifications which are considered to be more susceptible to the accumulation of moisture due to the building's intended function and use. The majority of moisture within a building is produced from washing (bathrooms and laundries) and cooking.

Condensation is a physical phenomenon that occurs naturally wherever and whenever the physical conditions are conducive. Mould often grows where condensation forms within the built environment. The principle physical drivers are air pressure, temperature and humidity. These same physical conditions can occur within all built structures, in all climate types within the building (its internal environment), within its intermediate zones (subfloor and roof space zones) and within the building structure (floor, walls, ceilings and roofing materials). These natural processes cannot be stopped from occurring where these conditions exist. However, buildings can be designed, constructed and used in a way that manages vapour pressure, condensation risk and subsequent mould growth.

Human occupation of a residential building creates approximately 10 litres of water vapour per person per day. In an average family home with two adults and one child this equates to 30 litres of water vapour within the built fabric per day. This comes from people breathing, cooking, boiling water, washing and bathing. The shift from unconditioned to conditioned homes and the requirements for wall and ceiling insulation have significantly impacted on the internal climate of homes and the potential for condensation to occur. This is primarily due to less air changes within the home and occupants being less likely to open windows and doors when the air-conditioning is running. Modern buildings are also much better sealed due to advances in building materials and systems.

Interstitial condensation can affect the structural integrity of a building but its presence often goes undetected until such time as the cost to remedy becomes significant. The most effective means to reduce the problem of interstitial condensation is to provide a pathway for water vapour that avoids the accumulation of condensation. To remove the risks associated with condensation and to maintain indoor air quality, moisture laden air needs to be removed from the building and expelled out to the external environment.

The design, construction and use of a building can create conditions that lead to a building experiencing prolonged periods of damp, which leads to poor indoor environmental qualities, (potentially affecting occupant health) mould, and building degradation. Occupant behaviour, for example opening windows and doors to ventilate the building, can significantly impact a building's indoor air quality but cannot be regulated by the NCC. The NCC's Part F6 Condensation Management requirements were included in the NCC to assist in addressing the risks associated with condensation in residential buildings.

Functional Statements

FF6.1 Condensation

A building is to be constructed to avoid the likelihood of excessive internal moisture accumulating within the building structure.

Performance Requirements

FP6.1 Condensation and water vapour management

Class 2 buildings and Class 4 parts of a building must be designed to mitigate the risks associated with the amount of moisture that accumulates internally.

Verification Methods

FV6 Condensation management

[FV6](#) describes a means of verifying that the effects of internal moisture will not accumulate to a degree which would detrimentally impact the health, safety or amenity of a building's occupants as described in [FO6](#).

Part F6 Condensation management

Deemed-to-Satisfy Provisions

F6.0 Deemed-to-Satisfy Provisions

Intent

To specify the minimum construction requirements to assist in the mitigation of condensation in buildings.

Where a solution is proposed to comply with the Deemed-to-Satisfy Provisions, [F6.0](#) clarifies that compliance with [F6.1](#) to [F6.4](#) will achieve compliance with [FP6.1](#).

Where a Performance Solution is proposed, the relevant Performance Requirements must be determined in accordance with [A2.2\(3\)](#) and [A2.4\(3\)](#) as applicable. (See commentary on [Part A2](#)).

F6.1 Application of Part

Intent

To clarify that [Part F6](#) only applies to Class 2 buildings and a Class 4 part of a building.

F6.2 Installation of pliable building membrane

Intent

To set out the requirements relating to pliable building membranes that are installed as a sarking.

Sarking is considered to be a pliable building membrane. All pliable building membranes must comply with AS/NZS 4200.1 and be installed in accordance with AS 4200.2. In climate zones 6, 7 and 8 pliable building membranes must be vapour permeable to assist in the transfer of moisture from the internal to the external environment. This recognises the higher level of risk associated with the build-up of internal moisture in colder climates particularly due to the inadequate ventilation of internal spaces. Any pliable building membrane must be installed with suitable provision to allow for the drainage of accumulated condensate to a drainage point external to the wall.

Where a pliable building membrane is not installed a drained cavity must be provided. Alternatively, a design can be assessed using Verification Method [FV1.1](#).

F6.3 Discharge of exhaust systems

Intent

To reduce risk of condensation associated with mechanical ventilation.

[F6.3](#) requires that kitchen, bathroom, toilet and laundry exhaust fans achieve specified minimum airflow rates. Requiring higher minimum airflow rates for laundries recognises the potential for much greater air moisture in the room and therefore the increased risk of condensation. This provision also requires that the specified exhausts discharge to the external environment or into a ventilated roof space in accordance with [F6.4](#).

F6.4 Ventilation of roof spaces

Intent

To set out the ventilation requirements relating to roof spaces.

[F6.4](#) requires that a roof space be ventilated where exhausts are discharged directly into the roof space. [F6.4](#) sets out the minimum unobstructed vented areas and locations relative to the pitch of the roof. Providing regularly distributed vents at both lower and upper levels assists in providing adequate cross flow ventilation.

Ancillary provisions

- | | |
|----------------|--|
| Part G1 | Minor structures and components |
| Part G2 | Boilers, pressure vessels, heating appliances, fireplaces, chimneys and flues |
| Part G3 | Atrium construction |
| Part G4 | Construction in alpine areas |
| Part G5 | Construction in bushfire prone areas |
| Part G6 | Occupiable outdoor areas |

Section G Ancillary provisions

Part G1 Minor structures and components

Objective

GO1

Functional Statements

GF1.1

GF1.2

GF1.3

GF1.4

Performance Requirements

GP1.1 Swimming pool drainage

GP1.2 Swimming pool access and water recirculation systems

GP1.3 Cool rooms

GP1.4 Vaults

GP1.5 Outdoor play spaces in early childhood centres

Deemed-to-Satisfy Provisions

G1.0 Deemed-to-Satisfy Provisions

G1.1 Swimming pools

G1.2 Refrigerated chambers, strong-rooms and vaults

G1.3 Outdoor play spaces

Part G2 Boilers, pressure vessels, heating appliances, fireplaces, chimneys and flues

Objectives

GO2

Functional Statements

GF2.1

GF2.2

Performance Requirements

GP2.1 Combustion heating appliances

GP2.2 Boilers and pressure vessels

Verification Methods

GV2 Combustion appliances

Deemed-to-Satisfy Provisions

G2.0 Deemed-to-Satisfy Provisions

G2.1 * * * * *

G2.2 Installation of appliances

G2.3 Open fireplaces

G2.4 Incinerator rooms

Specification G2.2 Installation of boilers and pressure vessels

1 Scope

2 Boilers and pressure vessels

Part G3 Atrium construction

G3.1 Application of Part

G3.2 Dimensions of atrium well

G3.3 Separation of atrium by bounding walls

G3.4 Construction of bounding walls

G3.5 Construction at balconies

G3.6 Separation at roof

G3.7 Means of egress

G3.8 Fire and smoke control systems

Specification G3.8 Fire and smoke control systems in a building containing atriums

- 1 Scope
- 2 Automatic fire sprinkler system
- 3 Smoke control system
- 4 Fire detection and alarm system
- 5 Emergency warning and intercom systems
- 6 Stand-by power system
- 7 System for excluding smoke from fire-isolated exits

Part G4 Construction in alpine areas**Objective**

GO4

Functional Statements

GF4.1

Performance Requirements

- GP4.1 External doorways
- GP4.2 Structures forming pathways in snow conditions
- GP4.3 Control of falling ice and snow
- GP4.4 Fire safety systems in alpine areas

Deemed-to-Satisfy Provisions

- G4.0 Deemed-to-Satisfy Provisions
- G4.1 Application of Part
- G4.2 * * * * *
- G4.3 External doorways
- G4.4 Emergency lighting
- G4.5 External ramps
- G4.6 Discharge of exits
- G4.7 External trafficable structures
- G4.8 Fire-fighting services and equipment
- G4.9 Fire orders

Part G5 Construction in bushfire prone areas**Objective**

GO5

Functional Statements

GF5.1

Performance Requirements

- GP5.1 Bushfire resistance
- GV5 Buildings in bushfire prone areas

Deemed-to-Satisfy Provisions

- G5.0 Deemed-to-Satisfy Provisions
- G5.1 Application of Part
- G5.2 Protection

Part G6 Occupiable outdoor areas**Objective****Functional Statements****Performance Requirements****Deemed-to-Satisfy Provisions**

- G6.1 Application of Part
- G6.2 Fire hazard properties
- G6.3 Separation of classifications
- G6.4 Provision for escape
- G6.5 Construction of exits
- G6.6 Fire fighting equipment

Ancillary provisions

G6.7 Lift installations

G6.8 Visibility in an emergency, exit signs and warning systems

G6.9 Light and ventilation

G6.10 Fire orders

Part G1 Minor structures and components

Objective

GO1

The Objective of this Part is to—

- (a) safeguard people from illness caused by the discharge of swimming pool waste water; and
- (b) protect other property from damage caused by the discharge of swimming pool waste water; and
- (c) safeguard young children from drowning or injury in a swimming pool; and
- (d) safeguard people from drowning or injury due to suction by a swimming pool water recirculation system; and

Application

GO1(d) only applies to a swimming pool with a depth of water more than 300 mm.

- (e) safeguard occupants from illness or injury resulting from being accidentally locked inside spaces which are designed to be entered for short periods of time only and in which occupation for longer periods may be hazardous; and
- (f) safeguard young children in outdoor play spaces.

Application

GO1(f) only applies to a Class 9b early childhood centre.

Coverage

GO1 relates to three distinct matters:

- **GO1(a)–(d)**—swimming pools;
- **GO1(e)**—the risk of people being locked in confined spaces; and
- **GO1(f)**—outdoor play spaces in an early childhood centre.

Swimming pools—**GO1(a)–(d)**

GO1(a) aims to minimise health risks to people from discharged waste water from a swimming pool. Such waste can spread disease.

GO1(b) relates to drainage from a swimming pool to protect other property from damage.

GO1(c) relates to preventing access of young children to swimming pools.

GO1(d) aims to prevent injury or drowning of people due to suction from a swimming pool recirculation system.

Accidental locking in small spaces—**GO1(e)**

GO1(e) aims to prevent illness or injury to people from being locked in small spaces which are only intended to be entered for short periods (e.g. cool rooms).

Early childhood centres—**GO1(f)**

GO1(f) aims to safeguard young children in an early childhood centre when playing in outdoor play spaces.

Functional Statements

GF1.1

Adequate means for the disposal of swimming pool water and drainage is to be provided to a swimming pool.

Swimming pool drainage

GF1.1 controls the drainage and disposal of water from swimming pools.

GF1.2

A swimming pool is to be provided with—

- (a) means of restricting access by young children to it; and

Ancillary provisions

(b) means to reduce the possibility of a person being entrapped or injured due to suction by a water recirculation system.

Application

GF1.2(b) only applies to a swimming pool with a depth of water more than 300 mm.

Swimming pools—access for young children GF1.2(a)

GF1.2(a) controls access by young children to swimming pools. This is to provide protection from illness, injury and death resulting from unsupervised access to swimming pools. Accordingly, systems designed as alternatives to the Deemed-to-Satisfy Provisions must be designed, approved and installed to provide equivalent restrictions to a young child.

Swimming pools—recirculation systems GF1.2(b)

GF1.2(b) controls swimming pool recirculation systems to reduce the possibility of people being entrapped or injured by the suction from the system.

GF1.3

Any refrigerated or cooling chamber, strong-room and vault or the like that is capable of accommodating a person is to have safety measures to facilitate escape and for alerting people outside such a space in the event of an emergency.

Accidental locking in small spaces

GF1.3 aims to make sure that people in confined spaces, such as cooling chambers, strongrooms and vaults, are able to:

- leave the space if the door accidentally closes; and
- alert people outside the confined space if there is an emergency.

GF1.4

An outdoor play space is to be provided with a means of restricting the passage of children to outside of the play space.

Application

GF1.4 only applies to a Class 9b early childhood centre.

Early childhood centres

GF1.4 aims to restrict the passage of children to the outside of an outdoor play space located in a Class 9b early childhood centre.

Performance Requirements**GP1.1 Swimming pool drainage**

GP1.1 relates to swimming pool drainage in two basic ways:

Prevention of illness—GP1.1(a)

To comply with GP1.1(a), it will generally be necessary that water must drain away from the pool surrounds and not flow on to the same or adjoining property. Such pooling could cause illness through:

- excessive moisture conditions degrading any building; and
- the creation of disease breeding grounds.

GP1.1(a) also aims to ensure that water is not left in puddles where people could slip. Water should not be left under decking, creating conditions for mosquito breeding and unhealthy pools of stagnant water.

Protection of other property from damage—GP1.1(b)

GP1.1(b) requires that pool water not affect other property. Measures must be taken to ensure that water drained from a pool does not affect other buildings.

No Deemed-to-Satisfy Provisions for GP1.1

There are no Deemed-to-Satisfy Provisions for GP1.1. This is because the solution to compliance with GP1.1 will vary considerably from allotment to allotment. This does not alter the fact that compliance must be achieved with GP1.1.

GP1.2 Swimming pool access and water recirculation systems**Swimming pools—access for young children**

GP1.2(a) relates to swimming pool barriers. Swimming pool safety fencing should be constructed so as to be impenetrable

Ancillary provisions

by young children, having regard to:

- the height and rigidity of the fence;
- any horizontal climbable members;
- openings and footholds in the fence; and
- the operation of self-closing and latching gates.

GP1.2(a)(i) requires barriers be continuous. However, the barrier does not have to be a single form or type of construction (e.g.: it may consist of allotment fences in combination with building walls).

A barrier must have sufficient structural strength to withstand people leaning or falling against it. Guidance on suitable structural loading criteria can be obtained from AS 1926.

GP1.2(a)(iii) requires that young children be prevented from entering the immediate pool surrounds.

GP1.2(a)(iv) requires any access gates or doors to be self-closing and latching.

Swimming pools—recirculation systems

GP1.2(b) requires a swimming pool water recirculation system to have appropriate safety measures to avoid the possibility of a person becoming entrapped by the suction of the system. Such entrapment in the past has led to injuries, and when it occurs under water, to drowning.

GP1.3 Cool rooms

Accidental locking in small spaces

GP1.3 relates to areas such as refrigeration and cooling chambers. It aims to maximise the safety of people working in them, by preventing them accidentally being trapped inside.

These provisions only relate to chambers of sufficient size for a person to enter.

GP1.3(a) requires a communication system to allow people within the chamber to alert others that they are trapped, etc. The communication system should be able to be seen or heard above any work going on in the building.

GP1.3(b) specifies that the egress route door must:

- be of sufficient size for an adult to move through; and
- be openable from the inside without a key at all times. (This provision overrides any corresponding requirements or concessions in [Section D](#)).

GP1.4 Vaults

GP1.4 aims to maximise the safety of people working in strongrooms and vaults of sufficient size to allow people to enter.

Within the vault there must be:

- means of communication with people in the building; and
- an internal light controlled only from within the room (i.e. there must be no override switch outside the vault).

Under GP1.4(c), there must be an indicator outside the vault which clearly shows if it is occupied. The indicator should be clearly marked as relating to the actual vault.

GP1.5 Outdoor play spaces in early childhood centres

Early childhood centres

GP1.5 aims to prevent children from going through, over or under fencing or barriers serving an outdoor play space in an early childhood centre. To prevent this from occurring, consideration needs to be made to the design of the gates and fittings in addition to the proximity of the barriers to any permanent structure on the property.

Part G1 Minor structures and components

Deemed-to-Satisfy Provisions

G1.0 Deemed-to-Satisfy Provisions

Intent

To clarify that:

- there are no Deemed-to-Satisfy Provisions for compliance with [GP1.1](#); and
- compliance with [GP1.2–GP1.5](#) will be achieved if compliance is achieved with [G1.1](#) and [G1.3](#).

No Deemed-to-Satisfy Provisions for [GP1.1](#)

There are no Deemed-to-Satisfy Provisions for [GP1.1](#). This is because the solution to compliance with [GP1.1](#) will vary considerably from allotment to allotment. This does not alter the fact that compliance must be achieved with [GP1.1](#).

Information on drainage requirements may be obtained from the appropriate authority. The legal discharge point from an allotment is generally determined by the appropriate local government authority.

G1.1 Swimming pools

Intent

To minimise the risk of young children sustaining injury as a result of gaining unsupervised access to a swimming pool.

Swimming pools—access for young children

[G1.1\(b\)](#) indicates that a barrier installed in accordance with AS 1926 Parts 1 and 2—*Swimming Pool Safety*, will form a suitable barrier to swimming pools associated with a Class 2 or Class 3 building or Class 4 part.

AS 1926 Part 2 provides a number of options for the location of swimming pool safety fencing.

Examples

Options for the location of safety fencing include:

- enclose the pool with isolation-safety fencing, separating the pool area from any other part of the allotment and any buildings;
- separate the pool area from other parts of the allotment, any buildings and neighbouring allotments, with barriers complying with the relevant Australian Standards provisions for safety fencing;
- if access is provided from the building to an indoor pool area, protect the access door and window openings to the pool area with child-resistant doorsets and child-resistant openable portions of window; and
- if a window forms part of the safety barrier to a swimming pool, the openable parts of the window must be child-resistant.

The operation of self-closing and latching devices on gates should allow it to close and latch from any position—from resting on the latching mechanism to fully open—in accordance with AS 1926 Part 1.

Water recirculation systems

The BCA definition of swimming pool is specific in including a bathing or wading pool and a spa. The requirements of AS 1926.3 apply to all types of pools defined as swimming pools under the BCA, irrespective of the definition in the Standard.

The swimming pool water recirculation system requirements seek to minimise the risk of entrapment or injury of people using the swimming pool and provide for the safe operation of skimmer boxes and outlet systems.

G1.2 Refrigerated chambers, strong-rooms and vaults

Intent

To maximise the ability of people working in a strongroom, refrigerated chamber, or the like, to escape the room in an emergency.

Accidental locking in small spaces

Ancillary provisions

G1.2(a) specifies the acceptable safety requirements for a cooling chamber, strongroom or vault which people can enter and work within. The door must be operable from the inside without a key (this requirement overrides any corresponding requirements or concessions in [Section D](#)). Also, there must be dedicated controls within the chamber, room or vault for internal lighting and an external indicator lamp to indicate the space is in use. Activation of the external indicator lamp can only be by operation of the internal light from within the chamber, room or vault.

G1.2(iii) requires a dedicated alarm to alert people outside that a person is trapped inside. The alarm must achieve the specified sound pressure level, and should be located where it will be noticed. The activation of the alarm must be controlled from within the chamber, room or vault, and must not be connected to an external device which can override the internal alarm controls.

G1.2(b) sets out the minimum door opening with specified dimensions for refrigerated or cooling chamber (the clear width criterion means that the measurements must be taken at the narrowest point of the opening, including any protruding door or door hardware).

G1.3 Outdoor play spaces

Intent

To safeguard young children in an early childhood centre when playing in an outdoor play space by restricting children from going through, over or under fencing or barriers serving an outdoor play space.

G1.3 specifies requirements for enclosure of an outdoor play space in a Class 9b early childhood centre. The provision requires a barrier to be provided to an outdoor play space.

G1.3(a) sets the requirement to provide a barrier in accordance with AS 1926.1.

G1.3(b) specifies that AS 1926.1 is applied as if there is a swimming pool located outside the outdoor play space. AS 1926.1 is designed to restrict children from gaining access to a swimming pool by enclosing the swimming pool with a barrier. The opposite approach is used when providing a barrier for an outdoor play space associated with a Class 9b early childhood centre where the intent is to restrict children from leaving the enclosed space without the knowledge of centre staff rather than gaining access to it. Therefore, elements of AS 1926.1 that would otherwise apply to the outside of a barrier where it is enclosing a swimming pool are applied to the inside of the barrier to an outdoor play space. Some examples of this include, but are not limited to, the following:

- The gate should swing into the play space in lieu of away from the play space.
- The non-climbable zone should be located on the inside face of the barrier, not the outside.
- Where a latch is provided at a height of less than 1500 mm from the finished ground level, the latch should be located on the outside of the gate, not the inside.

G1.3(c) exempts a wall which forms part of an early childhood centre from the requirements of [\(a\)](#). This is because access is still required to and within the play area, for general movement and for the children to access toilet facilities within the early childhood centre.

Part G2

Boilers, pressure vessels, heating appliances, fireplaces, chimneys and flues

Objectives

GO2

The Objective of this Part is to—

- (a) safeguard occupants from illness or injury caused by—
 - (i) fire from combustion appliances installed within a building; and
 - (ii) malfunction of a boiler or pressure vessel installed within a building; and
- (b) protect a building from damage caused by the malfunction of a boiler or pressure vessel installed within.

Combustion appliance—GO2(a)(i)

GO2(a)(i) specifies that people must be protected from injury by fire from a combustion appliance. GO2(a)(i) applies only to combustion appliances installed within a building.

Boilers and pressure vessels—GO2(a)(ii)

GO2(a)(ii) specifies that people must be protected from injury caused by a malfunction of a boiler or pressure vessel. GO2(a)(ii) applies only to boilers or pressure vessels installed within a building.

The malfunction of a boiler or pressure vessel could create steam and/or an explosion.

Protection of building—GO2(b)

GO2(b) requires that a building intended to contain a boiler or pressure vessel be designed so that any fault to the boiler or pressure vessel will not damage the building. The aim is to make sure that the structural stability of the building is not affected.

Functional Statements

GF2.1

Combustion appliances using controlled combustion located in a building are to be installed in a way which reduces the likelihood of fire spreading beyond the appliance.

Combustion appliances

GF2.1 requires that a heating system be installed to prevent fire spreading to adjoining building elements.

A key expression in GF2.1 is “controlled combustion”. This expression means that only heating units which burn solid materials or oil must comply with these provisions. The expression applies to open fireplaces, oil heaters, solid-fuel burning stoves, coal heaters, pot-belly stoves, and other such cooking and heating devices.

The expression does not include electric heaters. Nor is it intended to include gas heaters, covered by other State and Territory legislation.

GF2.2

Boilers and pressure vessels located in a building are to be installed in a manner which will provide adequate safety for occupants.

Boilers and pressure vessels

Additional measures must be taken when a boiler or pressure vessel is installed in a building, due to the potential damage and injury which may be caused by a malfunction.

Performance Requirements

GP2.1 Combustion heating appliances

When installed in a building, a combustion appliance (including all associated components) must be:

- designed to be robust enough to operate under all applicable heating conditions. It is particularly important that flue systems comply with this requirement, so they are compatible with the primary heating unit;

Ancillary provisions

- installed so that, when in operation, the radiated heat will not affect adjoining building elements (i.e. burn timber, warp steel lintels, char plasterboard and so on). This not only applies to the actual heating unit, but also to the attached flues, especially where they pass through other areas of the building (such as roofs, ceiling spaces, walls and the like); and
- designed and installed so that the hot products of combustion are properly discharged in a manner which will not cause damage. To do this, builders must make sure flues are adequately joined to create a continuous discharge route. The discharge point must be such that discharged products will not re-enter the building. They should not ignite adjoining combustible materials where the appliance is installed.

GP2.2 Boilers and pressure vessels

Because of the dangers of boilers and pressure vessels, care has to be taken during installation. Boilers and pressure vessels located outside a building are not covered by the BCA, but may be controlled by other State and Territory legislation. Issues such as leakage of pressurised liquids and the consequences of the vessel being damaged must be considered. Damage must be avoided to the vessel. Such damage could occur if the vessel is located in an area subject to traffic.

Verification Methods

GV2 Combustion appliances

Under [GV2](#), it needs to be demonstrated that the proposed appliance will not deteriorate under standard operating conditions. Examples of deterioration may include deformation or failure of components that would render the appliance unsafe to use.

For the purposes of demonstrating compliance with sub-clause [\(a\)](#), the typical operating temperature of a combustion device can be established by testing.

For the purposes of demonstrating compliance with sub-clause [\(b\)](#), materials used for building elements (walls, floors and ceiling) in the areas surrounding an appliance can be appropriately selected and/or designed to align with the quantified values as determined by sub-clause [\(a\)](#). This could either be achieved by using the expert judgement of an engineer or by adhering to manufacturer's specifications. Certification in accordance with CodeMark Australia would also be a possibility in demonstrating compliance using the Verification Method. Full range of thermal movements relates to both the appliance and materials when exposed to both the heated and ambient conditions.

Benefits to industry derived from the application of this Verification Method include the potential use of non-standard national or internationally manufactured appliances. For example, test reports for appliances complying with various ISO Standards and various British Standards could be used to demonstrate compliance with the Verification Method. The Verification Method also allows for in situ testing of unique combustion appliances, which would not easily be tested in accordance with the Australian Standard. Such testing would need to be verified by a suitably qualified practitioner and be supported by appropriate documentation.

Part G2

Boilers, pressure vessels, heating appliances, fireplaces, chimneys and flues

Deemed-to-Satisfy Provisions

G2.0 Deemed-to-Satisfy Provisions

Intent

To clarify that requirements of [GP2.1](#) and [GP2.2](#) will be satisfied if compliance is achieved with [G2.1–G2.4](#).

Where a solution is proposed to comply with the Deemed-to-Satisfy Provisions, [G2.0](#) clarifies that compliance with [G2.1–G2.4](#) achieves compliance with [GP2.1](#) and [GP2.2](#).

Where a Performance Solution is proposed, the relevant Performance Requirements must be determined in accordance with [A2.2\(3\)](#) and [A2.4\(3\)](#) as applicable. (See commentary on [Part A2](#)).

G2.1 * * * * *

In BCA 90 this provision was performance based. In subsequent editions of the BCA, the provision is covered by the Performance Requirements. [G2.1](#) has been left blank rather than renumber subsequent clauses.

G2.2 Installation of appliances

Intent

To specify the Australian Standards which are suitable to achieve compliance with [GP2.1](#) and [GP2.2](#) as regards the installation of domestic solid-fuel burning appliances, pressure equipment and the like.

Solid-fuel burning appliances and pressure equipment

[G2.2](#) lists one Standard as a Deemed-to-Satisfy Provision for the installation of domestic solid-fuel burning appliances (see [G2.2\(b\)](#)), and for boilers and pressure vessels [G2.2](#) refers to [Specification G2.2](#).

The requirements of [G2.2](#) limits the requirements to stove, heater or similar appliance in a building. Therefore the provision does not apply to boilers and pressure vessels outside of these limitations, such as portable gas appliances.

G2.3 Open fireplaces

Intent

To provide for the safe design and installation of open fireplaces.

The design and installation of open fireplaces

[G2.3](#) relates to open fireplaces where timber or other solid material is burned and there is generally no in-built enclosing structure or apparatus across the front to contain sparks, etc.

The construction of a fireplace must comply with the structural requirements in [Section B](#) of the NCC. The [G2.3](#) requirements relate to additional measures for fire safety.

[G2.3\(a\)](#) states that the fireplace must have a hearth made of stone, concrete or other similar non-combustible material. The non-combustible material must be similar in nature to stone and concrete. The concessions for non-combustible material in [Section C](#) of the NCC, particularly [C1.9](#) (such as plasterboard and similar lightweight materials), must not be construed as complying with these specific provisions.

With the increased danger due to the open-fire area, [G2.3\(a\)](#) contains requirements to ensure the area in front of the opening is protected. The hearth is intended not only to protect adjoining building elements from sparks, but also to reduce the danger of logs rolling out. See [Figure G2.3](#).

[G2.3\(b\)](#) deals with the construction of a fireplace (additional to the requirements of [Section B](#)). These relate to the fire box, and the need to ensure that the walls adjacent to the fire can withstand the heat. Concrete blockwork is not allowed to form the fire box, because it performs poorly under repeated heating and cooling cycles.

[G2.3\(c\)](#) contains the requirements for chimneys.

[G2.3\(c\)\(i\)](#) aims to make sure the masonry of a chimney is capable of withstanding heat. The construction requirements are less than those for the firebox, because the most intense area of the fire is below the actual level of the chimney.

Ancillary provisions

[G2.3\(c\)\(ii\)](#) contains a requirement to line the chimney with a rendering mix to make sure it draws properly. A smoother surface:

- allows a freer air-flow up the chimney, and therefore removes smoke more effectively; and
- helps to minimise soot build-up, therefore minimising the risk of chimney fires.

[G2.3\(d\)](#) contains a requirement to ensure that damp-proof courses and flashings are installed. Section 3.3 of Volume Two of the BCA contains some options for compliance.

G2.4 Incinerator rooms**Intent**

To provide requirements for the safe installation of an incinerator room in a building.

Incinerators, hoppers and incinerator rooms

[G2.4\(a\)](#) contains requirements for incinerators and their hoppers. “Hopper” refers to the area used to feed the incinerator. The requirements for hoppers aim to make sure they do not increase the risk of fire to the adjoining building area.

[G2.4\(a\)\(v\)](#) states that a hopper must not be located in a required exit. This is to prevent any potential problem where a failure in the hopper could affect the egress route.

[G2.4\(b\)](#) requires an incinerator to be fire separated from the remainder of the building.

Ancillary provisions

Figure G2.3 Fire place clearance from combustible materials

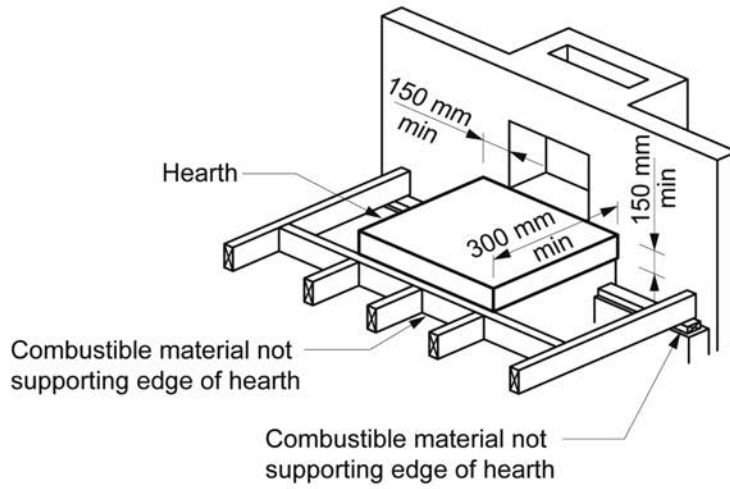

(a) Hearth construction

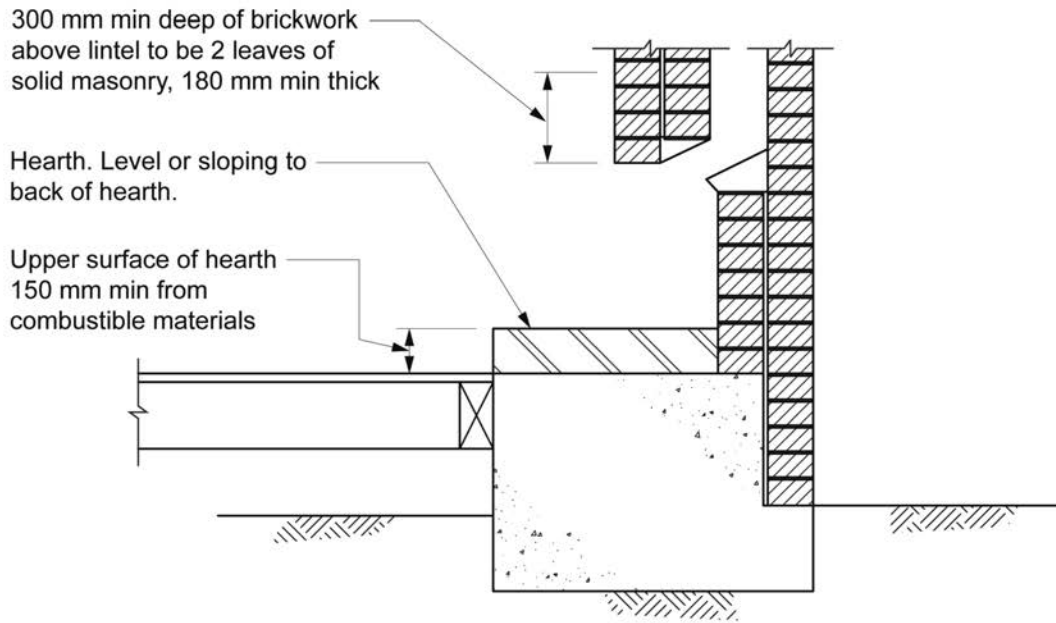

(b) Fireplace construction

Specification G2.2

Installation of boilers and pressure vessels

Deemed-to-Satisfy Provisions

[Specification G2.2](#) only applies to the Deemed-to-Satisfy Provisions.

1 Scope

Intent

To clarify that [Specification G2.2](#) includes the requirements for the installation of boilers and pressure vessels.

2 Boilers and pressure vessels

Intent

To specify the requirements for boilers and pressure vessels.

Explosion relief

[Clause 2.1](#) provides requirements for the distance between the vent of any explosion relief device and any adjacent wall, roof, ceiling or other solid construction. [Table 2.1](#) provides the minimum clearance required which is based on the volume of the space being vented. The minimum clearance is determined by a formula which includes the volume of the space being vented. The intention of the explosion relief provisions are that in the event of an explosion the extent of damage is limited.

The minimum clearance determined in the first row is 0.4 m from an adjacent wall or ceiling/roof.

The minimum clearance determined in the second row is 0.6 m from two walls at right angles, or one wall and a ceiling/roof. This scenario poses a higher risk of damage from overpressure experienced during deflagration, therefore the clearance is increased.

Ancillary provisions

Figure Spec G2.2 Explosion relief device clearance

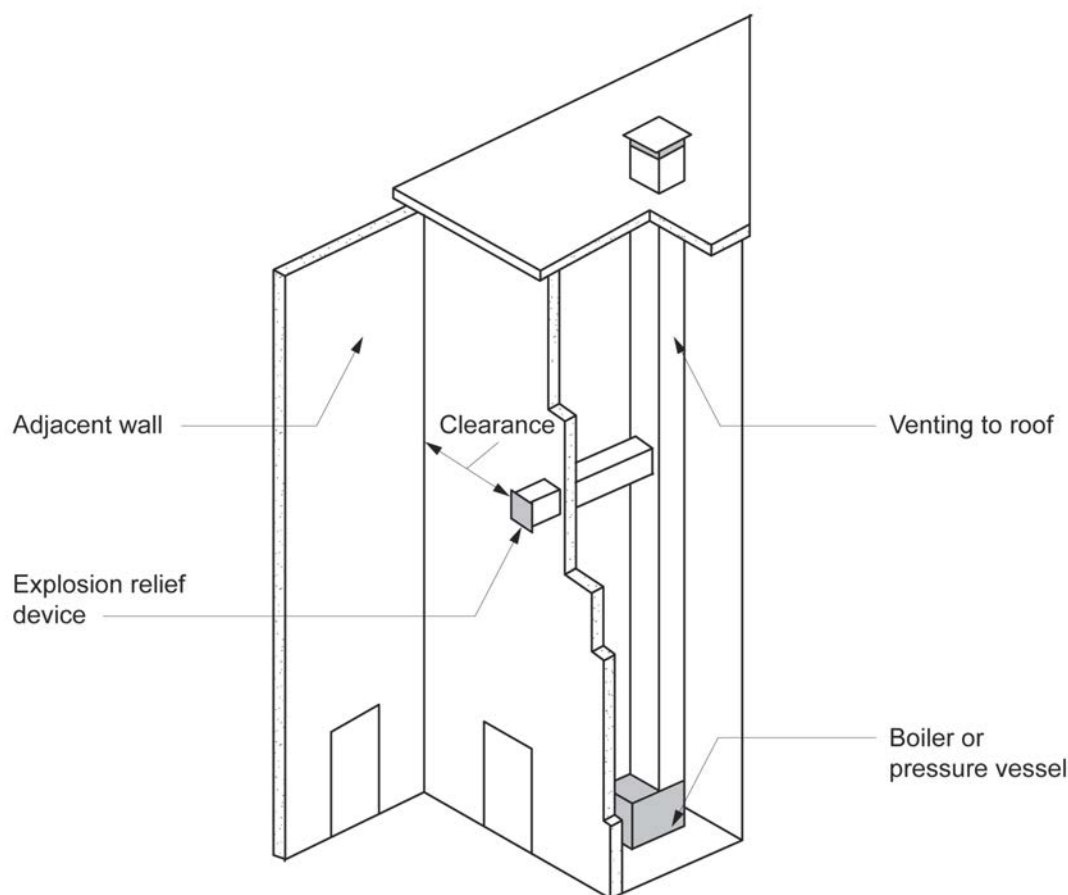
**Examples of compliance with Table 2.1**

V = Volume of space being vented (e.g. furnace to the flue connection)

For this example the volume is 5 m^3

x = Clearance from adjacent wall or ceiling/roof

y = Clearance from two walls at right angles; or one wall and a ceiling/roof

Example 1

$$x = 0.4(V/3)^{1/3}$$

$$x = 0.4(5/3)^{1/3}$$

$$x = 0.47 \text{ m}$$

Therefore the minimum clearance is 0.47 m.

Example 2

$$y = 0.6(V/3)^{1/3}$$

$$y = 0.6(5/3)^{1/3}$$

$$y = 0.71 \text{ m}$$

Therefore the minimum clearance is 0.71 m.

Floor and drainage

[Clause 2.2](#) contains two parts. The first is to require the floor surface beneath the boiler or pressure vessel to be water resistant and the floor to be graded away from supports and structural building elements. The second is to ensure that where a safe tray is provided, it must be of a material that is resistant to corrosion from the contents of the boiler.

Protection from heat

For steel, concrete and timber elements, [Clause 2.3](#) requires the protection of these elements to prevent exposure

Ancillary provisions

to certain temperatures emitted by a boiler or pressure equipment.

Part G3 Atrium construction

Objective**Functional Statements****Performance Requirements**

The Objectives and Functional Statements for [Part G3](#) are contained in [Sections C, D](#) and [E](#) of this Guide. The Performance Requirements for [Part G3](#) are in [Sections C, D](#) and [E](#). [Part G3](#) contains additional Deemed-to-Satisfy Provisions for buildings that contain an atrium.

Part G3 Atrium construction

Deemed-to-Satisfy Provisions

G3.1 Application of Part

Intent

To clarify which atriums must comply with [Part G3](#).

The BCA defines the term “atrium”. It is important to understand this BCA definition before considering [Part G3](#). See definition in [Schedule 3](#).

[Part G3](#) does not apply to an atrium if it connects two storeys in a non-sprinkler protected building, or up to three storeys if each of the connected storeys is sprinkler protected and one of those storeys is at a level giving egress to a road or open space.

This provision is consistent with [D1.12](#), which deals with the number of floors that can be connected by a non-required non-fire-isolated stairway, ramp or escalator.

G3.2 Dimensions of atrium well

Intent

To minimise the risk that radiant heat from a fire will affect people or materials on the other side of an atrium well.

The BCA defines the terms “atrium” and “atrium well”. It is important to understand these BCA definitions, before considering [Part G3](#). See definitions in [Schedule 3](#).

An atrium well is not limited to having a maximum size, nor is there a limitation on its shape, except that it must contain a space throughout which could contain a cylinder with a diameter of 6 metres. This 6 metres is equal to the minimum distance between unprotected openings in external walls of adjoining buildings required by [C3.2](#). This diameter void is intended to reduce the effects of radiant heat from a fire:

- affecting occupants evacuating on the other side of the atrium well; and
- igniting materials on the other side of the atrium well.

[Figure G3.2](#) illustrates the method of measuring the atrium well to comply with [G3.2](#) and the location of an atrium’s bounding walls.

Figure G3.2 Atrium well measurement and location of bounding walls

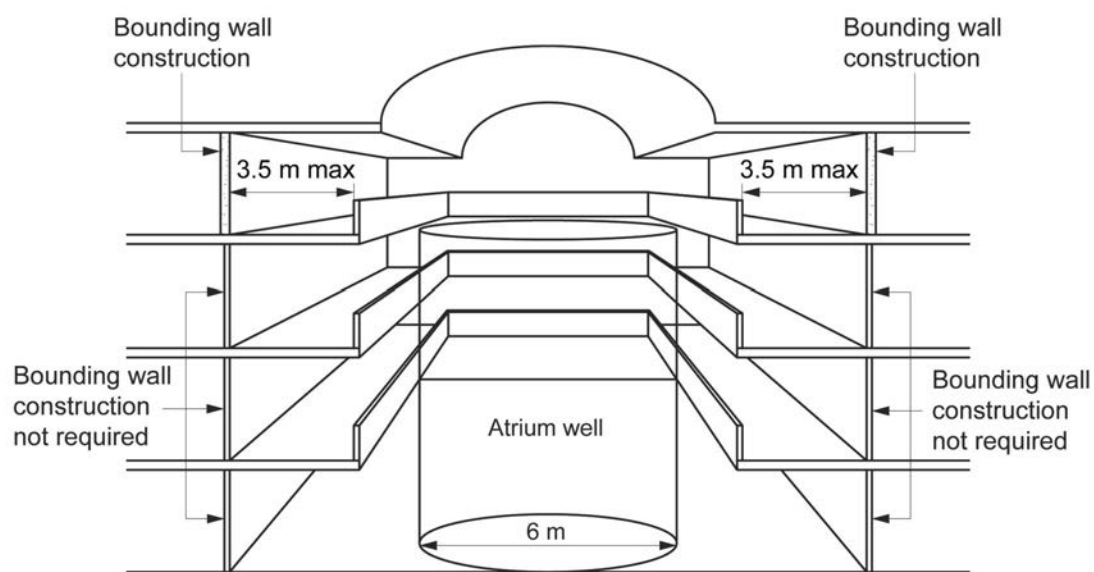

Ancillary provisions

G3.3 Separation of atrium by bounding walls

Intent

To minimise the risk of spread of fire and smoke from or to the atrium or other parts of the building.

G3.3 requires the use of bounding walls, which limit the risk of fire and smoke spreading from the atrium to other parts of the building and other parts of the building to the atrium.

The detailed requirements for bounding walls are explained in the Comments on [Clause 2.4 of Specification G3.8](#).

The bounding wall and 3.5 metre setback requirements do not apply where there are three or less consecutive storeys and:

- one of these storeys is located at the level from which direct egress is provided to a road or open space; and
- the total floor area of these storeys is limited to that specified in [Table C2.2](#) (the floor area referred to in [G3.3\(b\)](#) is that of the three storeys, and not the total floor of the atrium).

[Figure G3.3](#) illustrates the floors included in the area permitted by [Table C2.2](#).

[Figure G3.2](#) illustrates the location of an atrium's bounding walls.

Figure G3.3 Elevation showing floors of atrium included in the area permitted by Table C2.2

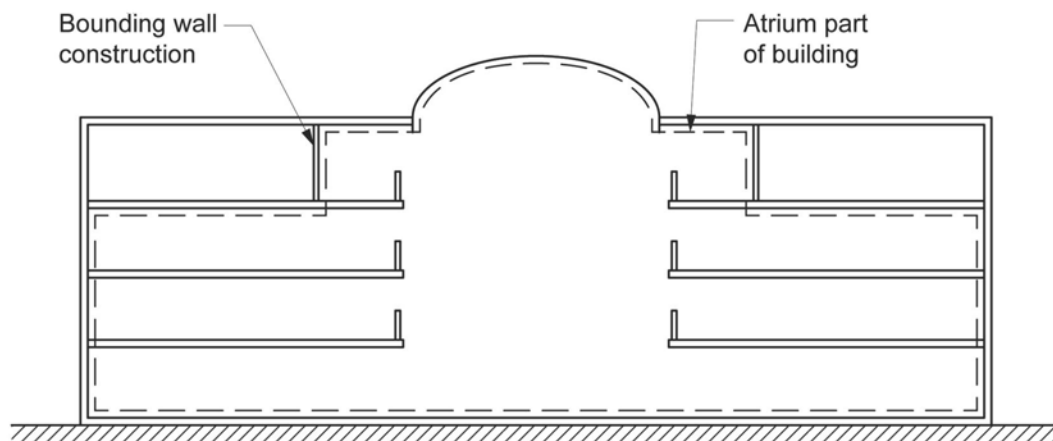

G3.4 Construction of bounding walls

Intent

To limit the spread of fire between different parts of a building by way of an atrium.

G3.4 establishes the required FRL and acceptable construction requirements for the bounding walls required by [G3.3](#). See [Figure G3.4](#).

The walls bounding an atrium are not fire walls as defined in the BCA. Therefore, these walls do not create separate fire compartments within a storey of the building. The bounding walls define the extent of the part of the building regarded by the BCA to be an "atrium". See [Figure G3.2](#).

G3.4 prescribes two options for construction of bounding walls:

- applies where the bounding walls are constructed of materials with a FRL of 60/60/60; or
- applies where the bounding walls are constructed of fixed toughened or wired safety glass in non-combustible frames.

Ancillary provisions

Figure G3.4 Examples of bounding walls complying with G3.4

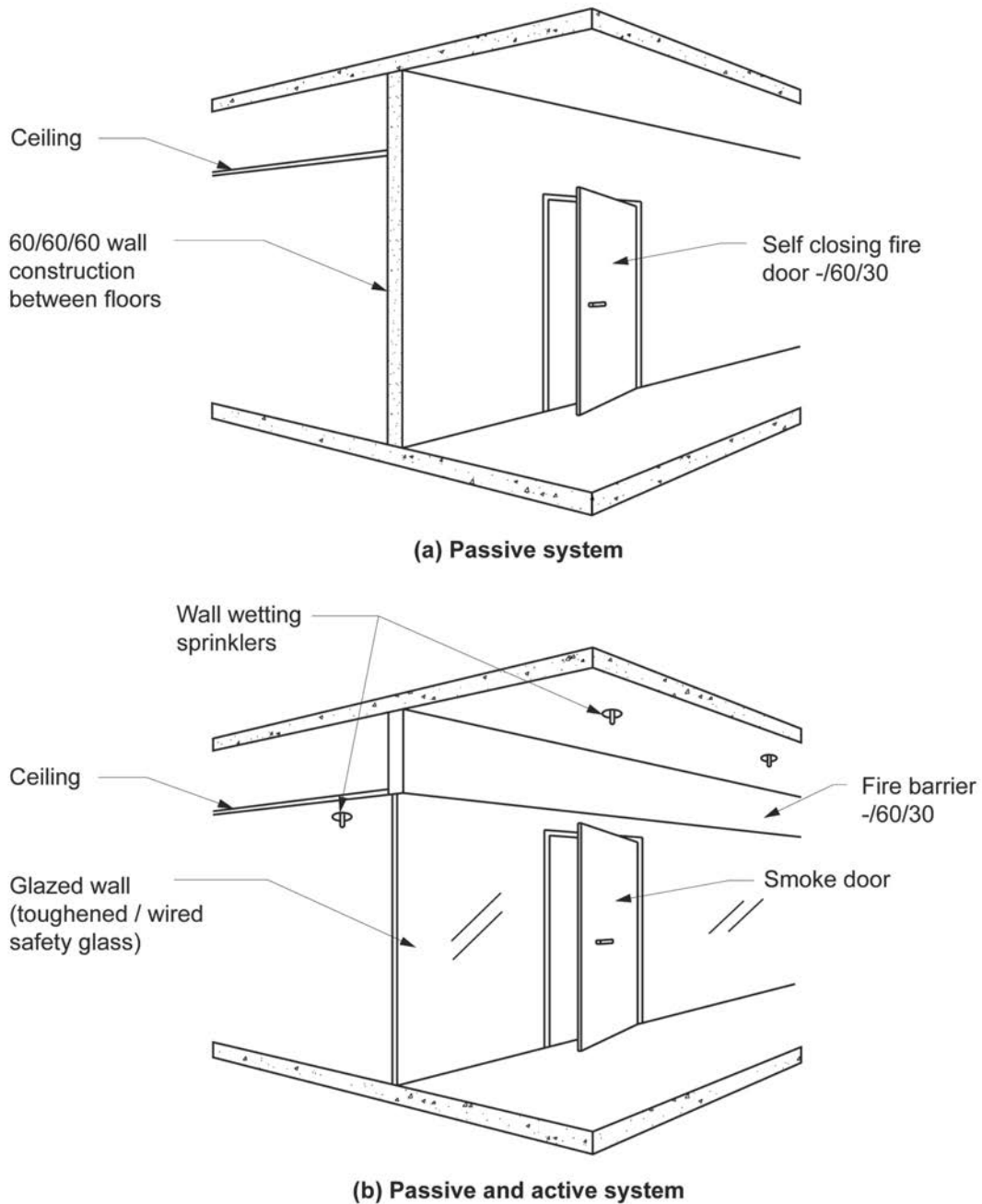

G3.5 Construction at balconies

Intent

To maximise the safety of people who have access around an atrium.

To maximise public safety, a barrier is required at the edge of a balcony to an atrium. The barrier must:

- have no openings and be non-combustible, to act as a shield from heat during a fire; and
- have a height of 1 metre—which is consistent with D2.16.

G3.5 takes precedence over the provisions of D2.16 for barriers around an atrium.

Ancillary provisions

G3.6 Separation at roof**Intent**

To minimise the risk that the roof of an atrium will not remain in place during a fire.

Clause 3 of Specification G3.8 requires smoke extraction through the roof, or near the top of an atrium—this smoke extraction is required to be by mechanical exhaust or by smoke and heat vents.

It is therefore important that the roof remains in place during a fire and not allow the re-circulation of smoke. To achieve this, G3.6 requires:

- the roof to have the FRL required by Table 3 of Specification C1.1; or
- the roof structure and membrane to be protected by a sprinkler system (other than a FPAA101D or FPAA101H system).

The materials used in the roof must comply with:

- the fire hazard properties specified in Specification C1.10; and
- when the roof is required to have an FRL, G3.6(a) does not allow the use of the concessions contained in Clauses 3.4, 3.5 or 3.6 of Specification C1.1 for the roof of the atrium.

G3.7 Means of egress**Intent**

To require that safe egress is available from an atrium.

Although the building may have an effective height of less than 25 metres, two exits are required from any area within an atrium. This is due to the additional fire hazard associated with atriums.

There may be other parts of the BCA which permit buildings to have only a single exit. G3.7 overrides any such provisions insofar as they relate to atriums.

All other aspects of the means of access and egress from an atrium must comply with Section D.

G3.8 Fire and smoke control systems**Intent**

To specify the additional fire and smoke control systems required for an atrium.

Because of the additional fire hazard associated with an atrium, special fire and smoke control measures are required to reduce the likelihood of conditions being reached which could endanger the safety of occupants before they have time to evacuate. These measures are set out in Specification G3.8.

Specification G3.8

Fire and smoke control systems in a building containing atriums

Deemed-to-Satisfy Provisions

[Specification G3.8](#) only applies to the Deemed-to-Satisfy Provisions.

1 Scope

Intent

To clarify that [Specification G3.8](#) includes the requirements for fire and smoke control systems in buildings with an atrium.

[Specification G3.8](#) includes the requirements for fire and smoke control systems in buildings containing an atrium. Where a sprinkler system is required, it must be installed in the whole building, not just that part in which the atrium is located.

2 Automatic fire sprinkler system

General requirement

Intent

To set out the general requirements for the installation of a suitable sprinkler system in a building containing an atrium.

Generally, a sprinkler system must comply with [Specification E1.5](#). The remainder of [Clause 2 of Specification G3.8](#) sets out additional requirements for sprinklers in a building containing an atrium.

If any conflict exists between [Specification E1.5](#) and [Clause 2](#), then [Clause 2](#) takes precedence.

Roof protection

Intent

To set out the roof protection requirements for a building containing an atrium.

[Clause 3](#) requires smoke extraction through the roof, or near the top of the atrium. It is therefore important that the roof remains in place during a fire and does not allow the re-circulation of smoke. To achieve this, [G3.6](#) requires the roof:

- to have the FRL required by [Table 3 of Specification C1.1](#); or
- structure and membrane to be protected by a sprinkler system (other than a FPAA101D or FPAA101H system).

[Figure Spec G3.8](#) illustrates the alternative protection of an atrium roof.

Ancillary provisions

Figure Spec G3.8 Alternative protection for atrium roof

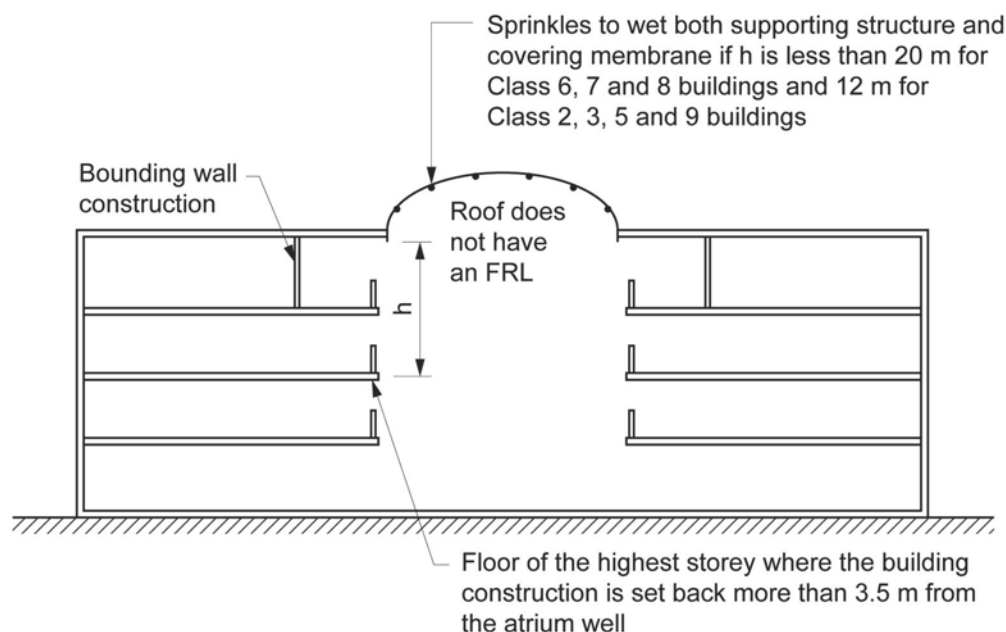

When the roof is required to have an FRL, [G3.6\(a\)](#) does not allow the use of the concessions contained in [Clauses 3.4, 3.5 or 3.6 of Specification C1.1](#) for the roof of the atrium.

The sprinkler protection requirement only applies to a roof located in an area where a fire could affect its integrity. The distances stated in [Clauses 2.2\(a\) and \(b\)](#) differ because of the different fire loads assumed in the different Classes of building. The heights of the atrium roof have been selected as those beyond which a smoke plume produced by a typical fire would no longer be hot enough to damage an unprotected roof.

The sprinkler heads need only be arranged to give a wetting effect to both the underside of the roof membrane and any part of the supporting structure.

The higher temperature rating of the sprinkler heads is to make sure they do not falsely discharge due to the potentially higher normal temperatures under an atrium roof, especially if a glass or translucent roof is used (as is common practice).

[Clause 3](#) requires smoke extraction through the roof, or near the top of an atrium. The smoke extraction is required to be by mechanical exhaust or by smoke and heat vents.

Atrium floor protection

Intent

To set out fire protection requirements for atrium floors (i.e. at the lowest level of the atrium).

Because of the height of the roof in an atrium, the sprinklers protecting it are unlikely to be effective at the lowest level of the atrium. Additional sprinklers are therefore normally required to protect that level, as this area is normally a large open space, and is potentially the primary source of a major fire. Adequate protection of the floor often requires the use of sidewall sprinkler heads, as required by [Clause 2.3\(a\)](#). [Clause 2.3\(a\)](#) requires a “performance-type” decision as to the types of sprinklers (sidewall and overhead) and their combination.

Because of the additional fire hazard associated with atriums, [Clause 2.3\(b\)](#) requires the use of fast response sprinkler heads.

Although a “fast response” sprinkler head can activate at the same temperature as a “normal” sprinkler head, its reaction time is much shorter and it has different discharge characteristics. Therefore, [Clause 5 of Specification E1.5](#) requires that the sprinkler system be designed specifically for the use of these heads.

Sprinkler systems to glazed walls

Intent

To set out fire protection requirements for glazed walls to an atrium.

[Clause 2.4.1](#) sets out the requirements for sprinkler protection of glazed bounding walls. These requirements are

Ancillary provisions

illustrated in [Figure G3.4](#).

Under [Clause 2.4.2](#), the location of the sprinkler heads must allow full wetting of the glazing without wetting an adjacent head. Consequently, water should run down the window, cooling the glass and therefore creating a resistance to the spread of fire or smoke through the glazed wall by reducing its potential to failure during a fire. It is also important that the adjacent sprinkler head not be wetted, because the cooling effect of the water may delay its activation.

Because of the additional fire hazard associated with atriums, [Clause 2.4.3](#) requires the use of “fast response” sprinkler heads.

Although a “fast response” sprinkler head can activate at the same temperature as a “normal” sprinkler head, its reaction time is much shorter and it has different discharge characteristics.

[Clause 2.4.4](#) sets out the minimum requirements for water discharge rates. [Clause 5 of Specification E1.5](#) therefore requires that the sprinkler system be designed specifically for the use of these heads.

[Clause 2.4.4](#) sets out the required water discharge rates on any glazing in a bounding wall. Because the atrium can have a high fire load and large volume, the higher flow rate of 0.25 L/s.m² is required on the atrium side of the glazing when the wall is not set back from the atrium well.

The importance of the wall sprinklers to glazed walls in a fire is such that [Clause 2.4.5](#) sets out the minimum potential coverage to be provided by such sprinklers, which in turn determines the characteristics of the water supply in terms of pressure and quantity.

The water supply for the wall wetting system referred to in [Clause 2.4.5](#) is additional to the water supply for the other sprinklers in the building.

It is assumed that the size of a fire will be controlled by the sprinkler system installed in the building. The greater height required to be covered by a wall wetting sprinkler system in a Class 6, Class 7 or Class 8 part of a building (see [Clause 2.4.5\(a\)\(ii\)](#)) reflects the greater fire load contained in such buildings.

Stop valves

Intent

To set out requirements for sprinkler and wall wetting system stop valves.

When referring to sprinkler and wall wetting stop valves, [Clause 2.5](#) requires that:

- they be monitored to detect and warn of any unauthorised closure; and
- the sprinkler and wall wetting systems have independent valves.

3 Smoke control system

General requirements

Intent

To set out the general requirements for the installation of a suitable smoke control system in a building containing an atrium.

As generally required by the BCA, mechanical air-handling systems must comply with AS 1668.1. However, if any conflict exists between AS 1668.1 and [Specification G3.8](#), the Specification takes precedence.

Operation of atrium mechanical air-handling systems

Intent

To set out mechanical air-handling system requirements for an atrium.

The basic operation of the mechanical air-handling system during a fire is to limit the spread of smoke. To achieve this it must:

- maintain a tenable atmosphere along balconies to allow the occupants to evacuate; and
- avoid smoke being drawn into the atrium when a fire occurs in another part of the building, which requires that—
 - the atrium smoke exhaust fans activate only when smoke enters the atrium;
 - the atrium cannot be used as a return air path; and
 - the normal relief or exhaust fans in the atrium must stop normal operation. If necessary, these fans may be designed for exhausting smoke from the atrium.

Ancillary provisions

The intent of the details contained in [Clause 3.2\(d\)](#) and [\(f\)](#) is to create a negative air pressure on the fire floor or in the fire affected compartment, so that air and any entrained smoke is drawn to it. This creates positive pressure on non-fire floors, so as to prevent the migration of smoke to non-fire floors while exhausting smoke from a fire affected floor.

Activation of smoke control system

Intent

To set out how a smoke control system serving an atrium is to be activated.

The smoke control system may be activated by any of the methods listed in [Clause 3.3\(a\)](#).

The location of the controls for the system may be any of those listed in [Clause 3.3\(b\)](#). Note that the locations are in areas normally accessed and used by the fire brigade during a fire.

Smoke exhaust system

Intent

To set out the design characteristics of a smoke exhaust system serving an atrium.

[Clause 3.4](#) specifies the characteristics on which a smoke exhaust system design must be based, which are:

- the size to which the sprinkler system will limit a fire, in terms of its heat output and perimeter;
- the extent of any smoke plume; and
- the system's discharge rate, as calculated under [Figure 3.4](#) of the BCA.

[Figure 3.4](#) of the BCA must be used to determine the minimum smoke extraction rate from the atrium. The required rate depends on the fire load specified in [Clause 3.4\(a\)](#) and the height of the smoke plume above the floor of the atrium well specified in [Clause 3.4\(b\)](#).

The exhaust rates are based on the need to maintain the smoke plume safely above any egress path.

Upward air velocity

Intent

To enable the movement of smoke to the roof, for venting externally.

If the smoke is allowed to travel up the atrium due to its own buoyancy, in higher atriums it will reach a stage where it will not travel any higher. The reasons for this include:

- the smoke will not have enough buoyancy to reach the top of the atrium; and
- the smoke will entrain air, and cool as it rises.

Accordingly, to make sure the smoke continues to travel up the atrium well, minimum (see [Clause 3.5 \(a\)](#)) and maximum (see [Clause 3.5\(b\)](#)) air velocities are specified. The maximum velocity specified in [Clause 3.5\(b\)](#) only applies to an atrium well with a constant plan cross section.

Exhaust fans

Intent

To set out the operational requirements for exhaust fans.

To make sure that exhaust fans operate effectively during a fire, they must be designed to operate for at least 1 hour at a temperature of 200°C (see [Clause 3.6\(a\)](#)).

Under [Clause 3.6\(b\)](#) and [\(c\)](#), to make sure that at least one fan continues to operate during a fire:

- at least three fans are required in atriums adjoined by Class 2, Class 3 or Class 9 parts, because of the heightened risk levels in such areas. This is due to such factors as the possibility that people will be sleeping and, in Class 9a buildings, the presence of non-ambulatory occupants; and
- at least two exhaust fans are required in all other atriums.

Smoke and heat vents

Intent

To set out requirements for smoke and heat vents, which are permitted in low-rise atriums.

Smoke and heat vents are permitted in low-rise atriums (i.e. atriums less than 12 metres high), instead of a

Ancillary provisions

mechanical smoke extraction system.

The reason for the [Clause 3.7\(a\)](#) limit is that 12 metres is considered to be a height to which smoke will travel due to its own buoyancy and still be effectively vented.

[Clause 3.7](#) does not apply where a Class 6 part of a building adjoins the atrium.

[Clause 3.7\(b\)](#) requires that vents be fitted with a manual override switch, for use as necessary by emergency services personnel.

Make-up air supply

Intent

To set out requirements for air flow into an atrium from which smoke-laden air is being extracted.

[Clauses 3.1](#) to [3.7](#) require that smoke-laden air be exhausted from an atrium. [Clause 3.8](#) sets out how this exhausted air is to be made-up (i.e. replaced) in the atrium.

[Clause 3.8\(a\)](#) is a performance criterion that requires make-up air to be provided from outside the atrium at a level at or near the lowest storey of the atrium and non-fire storeys.

To make sure that the area where the bounding walls are set back from the atrium well is kept smoke free, an air velocity of 0.1 m/s is required by [Clause 3.8\(b\)](#). This velocity is consistent with that required through an open door by a fire-isolated stairway pressurisation system which accords with AS 1668.1.

[Clause 3.8\(c\)](#) provides a means of achieving [Clause 3.8\(a\)](#). It is important that the make-up air assists (and does not disturb) the exhausting of the smoke layer. To achieve this, the make-up air should enter the atrium at as low a level as possible, preferably at the base of the atrium. The make-up air must be provided from:

- openings designed to open to outside air on detection of a fire in the atrium;
- a system of ducts to supply outside air to the atrium; or
- a combination of the above.

If a system of ducts is used to supply the make-up air, to make sure the system operates when needed during a fire, the ducts must have an FRL of 60/60/60 if they pass through a different fire compartment to the atrium.

4 Fire detection and alarm system

Intent

To set out the general requirements for the installation of a suitable fire detection and alarm system in a building containing an atrium.

General

A building's fire detection and alarm system must, in general, comply with AS 1670.1. However, if any conflict exists between AS 1670.1 and [Specification G3.8](#), the Specification takes precedence.

Smoke detection system

Intent

To set out requirements for smoke detectors in an atrium.

[Clause 4.2](#) sets out, in detail, the requirements for smoke detectors within an atrium. The aim of these requirements is to make sure that the smoke detection system operates effectively and false alarms are minimised.

Smoke detection in spaces separated from the atrium by bounding walls

Intent

To set out requirements for smoke detectors at return and relief air openings.

[Clause 4.3](#) sets out the requirements for smoke detectors at return and relief air openings.

Alarm systems

Intent

To set out requirements for alarm systems in a building containing an atrium.

Alarm systems required in a building containing an atrium, must include a break glass alarm at each door to a fire-isolated exit. The aim of this provision is that a person is able to break the glass setting off the alarm as they evacuate

Ancillary provisions

the building.

Where a sampling type smoke detection system is provided, a staged alarm must be given. The stages are set out in [Clause 4.4\(b\)\(i\) to \(iii\)](#). The reason for the staged alarms is to minimise the occurrence of false alarms.

Under [Clause 4.4\(c\)](#), beam and point type smoke detectors (as with a sampling type smoke detection system) must also operate as set out in [Clause 4.4\(b\)\(i\) to \(iii\)](#), but at the levels set in AS/NZS 1670.1. This provision only applies to beam and point type smoke detectors required by the BCA.

5 Emergency warning and intercom systems

Intent

To require that a suitable emergency warning and intercom system is installed in a building containing an atrium.

[Clause 5](#) requires the installation of an emergency warning and intercom system in any building containing an atrium. The system must comply with:

- AS 2220.1 and AS 2220.2; and
- the additional requirements set out in [Clause 5\(b\)](#).

The system is a combination of an emergency warning system and an emergency intercom. The main function of an integrated system is:

- to generate an alert and evacuation signal;
- to facilitate communication with evacuation zones; and
- to provide communication between the building management or emergency services personnel and strategic points within the building.

The operation of the system may be by a number of measures referred to in [Specification G3.8](#), including the break glass alarm required by [Clause 4.4\(a\)](#).

6 Stand-by power system

Intent

To require the installation of a suitable standby power system in a building containing an atrium.

[Clause 6](#) only applies where a required path of travel to an exit passes through an atrium (see [Clause 6\(a\)](#)).

Under [Clause 6\(a\)](#), because of the need to continue the operation of emergency services, a standby power supply is required. This is particularly important because of the increased fire hazard associated with atriums, and the dangers for occupants if they have to evacuate through atriums.

To make sure it operates when needed during a fire, the standby power supply must:

- automatically come into operation when the normal power supply fails;
- if located within the building, be protected by fire-resisting construction;
- be connected to the safety systems by means of cabling suitable to resist fire; and
- come from two supply sources.

[Clause 6](#) is consistent with the protection required for electricity supply systems in [C2.13](#).

[Clause 6\(c\)](#) sets out means of achieving [Clause 6\(a\)](#). To make sure that the necessary power to operate the emergency equipment is available during a fire, it requires the standby power to be from one of the listed alternatives.

7 System for excluding smoke from fire-isolated exits

Intent

To minimise the risk of smoke entering a fire-isolated exit in a building containing an atrium.

Reference to [E2.2](#), and in particular [Table E2.2\(a\)](#), means that all fire-isolated exits serving an atrium must be provided with a pressurisation system in accordance with AS 1668.1. The reason for this is the additional fire hazard associated with atriums and for occupants evacuating them.

Part G4 Construction in alpine areas

Introduction

Special provisions for alpine area construction—reasons

Accident potential from combustion heaters

Due to the extreme cold, the use of open-fire places and other heating devices is common. This increases the potential for accidents and the possibility of fire.

Sub-zero temperatures

Buildings constructed in alpine areas need special consideration because of sub-zero temperatures. The temperatures can create elements which restrict free movement to and from the building. They can also complicate the role of fire brigades and other emergency services.

Alpine areas

[Part G4](#) only applies in “alpine areas”. In NSW, ACT, or Victoria, this means areas more than 1200 metres above Australian Height Datum (AHD). In Tasmania, it is more than 900 metres above the AHD. See [Figure G4.1](#).

Objective

GO4

The Objective of this Part is to safeguard occupants in alpine areas from illness or injury from an emergency while evacuating a building.

Application

[GO4](#) applies to a building constructed in an alpine area and overrules other provisions of the BCA.

Protection while evacuating

[GO4](#) specifies that occupants of buildings in alpine areas must be protected while evacuating in an emergency. The protection measures are only required to assist while the building is being evacuated. The additional measures included in [Part G4](#) are necessary because of the conditions which can exist in alpine areas.

Precedence over other BCA provisions

[GO4](#)'s Application provision clarifies that if there is any contradiction between the requirements in this Part and the rest of the BCA, then the provisions of [Part G4](#) will take precedence.

Functional Statements

GF4.1

A building in an alpine area is to be provided with additional measures in view of the increased difficulties in fire-fighting and maintaining access and means of egress in snow conditions.

Application

[GF4.1](#) applies to a building constructed in an alpine area and overrules other provisions of the BCA.

Additional safety measures necessary

[GF4.1](#) adds an additional dimension to [GO4](#) by indicating that additional measures are necessary because of the difficulties faced by fire brigades in gaining quick access to buildings during an emergency, and maintaining building access and egress during snow conditions.

Precedence over other BCA provisions

The application provision included as part of [GF4.1](#) clarifies that if there is any uncertainty between the requirements in this Part and the rest of the BCA, then the provisions of [Part G4](#) will take precedence.

Performance Requirements**GP4.1 External doorways****External doors must continue to operate**

GP4.1 requires external doors to continue to operate effectively in snow conditions so people can leave in an emergency by the normal egress route (i.e. the doorway).

Such a doorway must not be made inoperable by deposits of snow and ice. Care needs to be taken to avoid locating doorways where:

- snow falling from adjoining roof areas could affect egress paths; and
- re-entrant corners of a building increase the potential for snow to be trapped.

Precedence over other BCA provisions

GP4.1's Application provision clarifies that if there is any uncertainty between the requirements of GP4.1 and the rest of the BCA, then GP4.1 will take precedence.

GP4.2 Structures forming pathways in snow conditions**External trafficable structures must be usable**

Any external structures used as part of an egress route must remain accessible in snow conditions. An external balcony not designed for egress from the building would not need to comply.

To comply with this provision it is necessary to make sure that snow build up is avoided and that the surfaces reduce the potential for people slipping.

Precedence over other BCA provisions

GP4.2's Application provision clarifies that if there is any uncertainty between the requirements of GP4.2 and the rest of the BCA, then GP4.2 will take precedence.

GP4.3 Control of falling ice and snow**Adjacent areas—snow or falling ice**

Areas adjacent to the building should not be subjected to heavy deposits of built-up snow or falling ice which could harm:

- people evacuating (i.e. roofs must be designed to avoid depositing snow on egress routes from the building); and
- people using the area adjacent to the building (ie snow from the roof area should not cascade on to public thoroughfares and roads or on to adjoining property in a dangerous manner).

Precedence over other BCA provisions

GP4.3's Application provision clarifies that if there is any uncertainty between the requirements of GP4.3 and the rest of the BCA, then GP4.3 will take precedence.

GP4.4 Fire safety systems in alpine areas**Installation of fire safety equipment**

GP4.4(a) requires that a building have equipment to facilitate firefighting operations. With the increased risk of fire development and access problems for fire brigades in alpine areas, it is important that suppression equipment be available to combat a fire in its early stages of development, to possibly prevent the fire reaching an uncontrollable stage.

It is not intended that occupants fight a fire if there is any danger to them. It is essential that occupants be able to evacuate safely before untenable conditions are reached.

Care will need to be taken in design and construction to ensure that water in fire-suppression equipment will not freeze, making the equipment useless.

GP4.4(b) requires the installation of a system to alert occupants of an emergency. Where an external alarm is installed, care must be taken that the sub-zero temperatures do not freeze its mechanism.

Precedence over other BCA provisions

GP4.4's Application provision clarifies that if there is any uncertainty between the requirements of GP4.4 and the rest of the BCA, then GP4.4 will take precedence.

Part G4 Construction in alpine areas

Deemed-to-Satisfy Provisions

G4.0 Deemed-to-Satisfy Provisions

Intent

The requirements of [GP4.1–GP4.4](#) will be satisfied if compliance is achieved with [G4.1–G4.9](#) in the case of buildings in alpine areas and for occupiable outdoor areas, [Part G6](#).

G4.1 Application of Part

Intent

To clarify that Part G4 applies only to buildings in alpine areas, and its provisions override any others in the BCA which are in conflict.

Buildings in alpine areas only—[G4.1\(a\)](#)

[G4.1\(a\)](#) indicates that the requirements of [Part G4](#) only apply to buildings constructed in an alpine area. See the definition of Alpine area in [Schedule 3](#).

Precedence over other provisions—[G4.1\(b\)](#)

[G4.1\(b\)](#) indicates that the provisions of [Part G4](#) take precedence over any other provisions in the BCA, but only if they are in conflict.

G4.2 * * * * *

This provision was blank in BCA 1990. [G4.2](#) has been left blank rather than renumber subsequent clauses.

G4.3 External doorways

Intent

To enable people to evacuate a building in an alpine area in an emergency without being impeded by snow and ice.

Inwards opening external doors

Doors in non-alpine areas

In most buildings, exit doors must open outwards to assist with evacuation. The outward opening door swings in the direction of people leaving the building. A door opening towards people leaving is considered to be potentially more dangerous because a “crush” may occur, where people pushing against the door prevents it from being opened.

Doors in alpine areas—[G4.3\(a\)](#) and [\(b\)](#)

In alpine conditions, the swing of outward opening doors may be impeded by snow and ice outside. Therefore, the door is allowed to open inwards provided adequate precautions are taken to enable the door to open towards the flow of people.

As external doors in most buildings open outwards, most people will not necessarily be expecting a door to open inwards. Accordingly, a readily-visible and understood sign must alert people to this feature.

Doorways protected by alcoves or similar

Doorways protected from snow build-up by alcoves, etc are effectively exempt from [G4.3](#), so long as they are clearly not subject to the build up of snow.

Alcoves—[G4.3\(d\)](#)

Where a doorway serves a corridor or stairway, an alcove or recess must be provided to protect against snow build-up. If a design indicates that such an alcove or recess will prevent snow build up, a builder, etc may be able to adopt the approach referenced above, and avoid the necessity for the door to open inwards. See [Figure G4.3](#).

[G4.3\(d\)](#) does not apply where an external doorway opens directly from a room to the outside of the building.

Ancillary provisions

Figure G4.3 Minimum dimensions of alcove or recess at external doorway

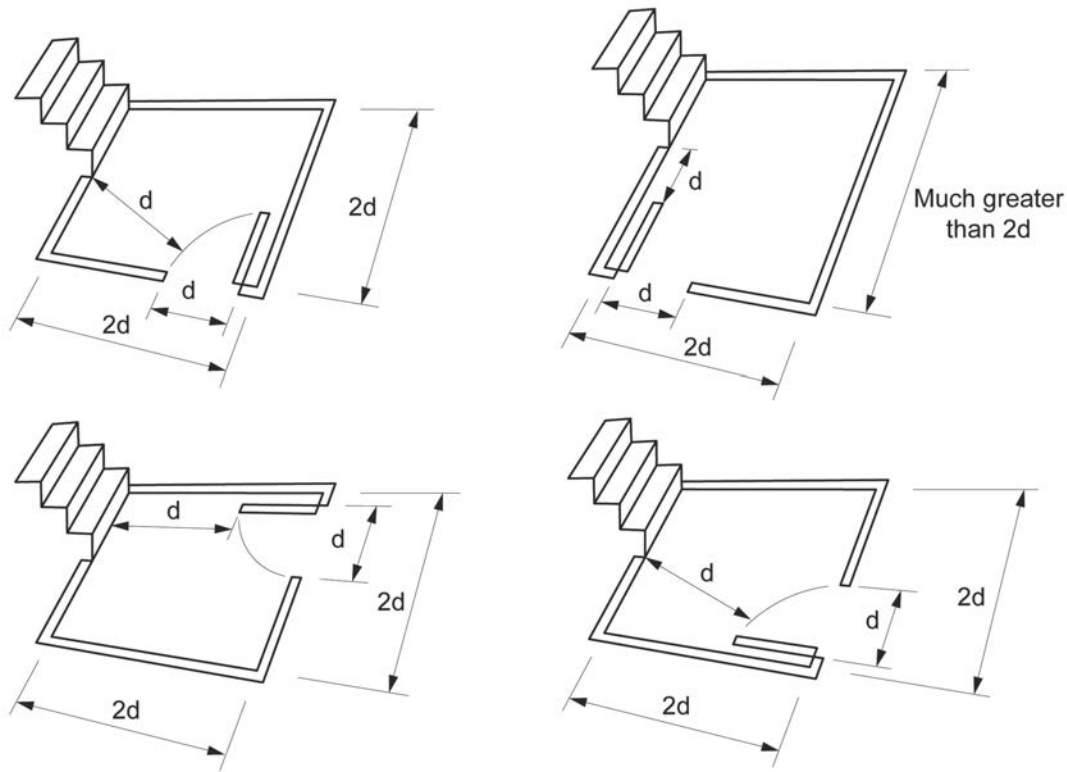
**Thresholds to required exit doorways—G4.3(c)**

Every threshold to a required exit doorway must be located so that snow, etc will not prevent the door from opening. Accordingly, the threshold may need to be:

- elevated to a point where it is above anticipated snow levels in that area of the building; or
- protected by an awning or similar enclosure which prevents snow from obstructing the doorway.

Attention should be given to the geometry of the building where the threshold is located. The doorway should not be in a place where the roof will deposit large amounts of snow, or at re-entrant corners where snow drifts may form.

G4.4 Emergency lighting**Intent**

To enable people to evacuate a building in an alpine area in an emergency without being impeded by lack of light.

Emergency lighting in buildings in alpine areas

G4.4 requires emergency lighting in all Class 2–9 buildings in alpine areas. Expected delays in emergency personnel arriving on the scene, means emergency lighting is necessary to assist people evacuating.

Emergency lighting provides illumination for exit paths, etc during a power failure (which is a likely scenario in a fire). The lighting must be effective and installed to cover exit paths as nominated.

G4.4 and Part E4

The technical aspects of the installation of emergency lighting must be in accordance with Part E4. However, the location of emergency lights must comply with G4.4, irrespective of any location parameters specified in Part E4.

Lighting in stairways—G4.4(a)

G4.4(a) requires lighting to be provided to every stairway within a building, except within a sole-occupancy unit of a Class 2 or 3 building and the Class 4 part of a building. This is to make sure that common exit routes are still negotiable in an emergency.

Lighting in exit paths—G4.4(b)

G4.4(b) requires lighting in main exit paths. The key description is public corridors, public hallways or the like, inferring that any pathway used as a general or common exit route by occupants must be provided with emergency lighting.

Ancillary provisions

Emergency lighting—G4.4(c)

G4.4(c) requires emergency lighting externally above every doorway opening to a road or open space. This enables occupants to negotiate any obstacles when evacuating in darkness.

G4.4(c) applies only to doorways leading directly or via the allotment land to a public road. Doorways opening on to enclosed courtyards or similar enclosed areas are not required to comply.

Emergency lighting and darkness—G4.4(d)

G4.4(d) is a performance criterion, and will require assessment of the building layout to determine the need for emergency lighting in areas other than those specified in G4.4(a), (b) and (c). The aim of G4.4 is to assist people by providing illumination in paths of travel while evacuating the building.

Where the designer or appropriate authority believes there are problems which may be created due to darkness, then emergency lighting must be installed.

Exit signs— Part E4

Note that while it is not referenced in Part G4, emergency exit signs need to be installed in accordance with Part E4.

G4.5 External ramps

Intent

To enable people to evacuate a building in an alpine area in an emergency without being impeded by steep ramps.

External ramps must not be too steep

G4.5 aims to ensure that egress is not impeded by steep ramps. The maximum slope of 1:12 is less than the 1:8 allowed in Part D2 because of the difficulty associated with negotiating ramps in snow and ice conditions. G4.5(a) acknowledges that if exit ramps are required for access by people with disabilities they must comply with AS 1428.1.

G4.6 Discharge of exits

Intent

To enable people to evacuate and emergency services to access a building in an alpine area in an emergency without being impeded by snow build-up around the building.

Snow build-up between and around buildings

The design and construction of a building in an alpine area must not aid dangerous levels of snow build-up between and around buildings. This control:

- assists with egress in an emergency;
- helps vehicle access around the buildings, both for snow clearing and emergency situations; and
- minimises the risk of snow or ice falling from the roof on to adjoining lots or egress routes.

G4.6(a) addresses the set-back distance for external walls from the boundary of adjoining allotments. The aim is to make sure that a reasonable distance is created between buildings to reduce the amount of snow build-up between properties.

G4.6(a) applies only to the area adjacent to that part of the wall which is more than 3.6 metres in height.

G4.6(b) describes distances between wings of a building where the exit doorway discharges into this area. The external walls of a building should not create an alcove which traps snow, making evacuation difficult.

G4.6(c) deals with the problem of features adjacent to an exit doorway which could trap snow and complicate egress.

The term “barrier” is used to describe the feature which could entrap snow. Because the aim of G4.6(c) is to avoid the problems created by snow drifts, it would be reasonable to interpret “barrier” as including any feature which could hold the snow, including fences, cuttings to roadways, walls of adjacent buildings and the like. See Figure G4.6.

Ancillary provisions

Figure G4.6 Discharge of External Doorways in alpine areas

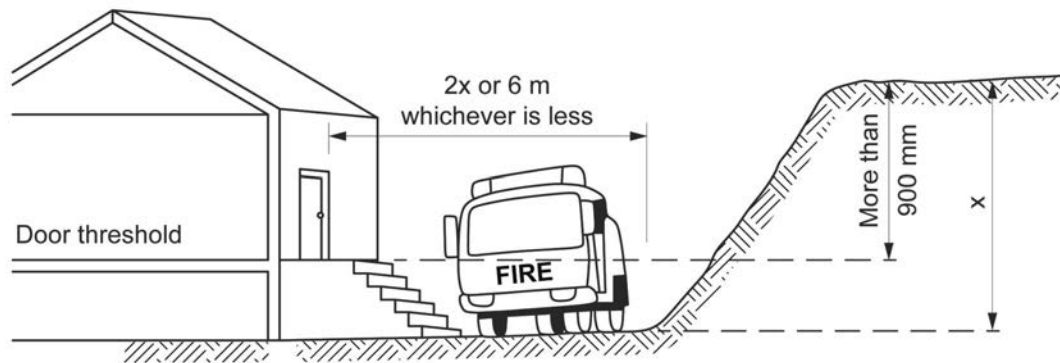

G4.7 External trafficable structures

Intent

To enable people to evacuate and emergency services to access a building in an alpine area in an emergency without being impeded by inadequate structures comprising part of the exit path of travel to a safe place.

Slipperiness and safe barriers

G4.7 aims to make sure that external structures comprising part of the exit path of travel from a building to a safe place:

- have a floor surface preventing people from slipping; and
- have any required barrier (i.e. required by Part D2) designed so that it is more than 75 per cent open to minimise snow build-up.

This provision only applies to structures, and not to such paths of travel as steps and ramps created by landscaping.

G4.8 Fire-fighting services and equipment

Intent

To provide for the installation of adequate fire safety equipment suitable to the conditions experienced in alpine areas.

Fire alarm system—G4.8(a)(i)

G4.8(a)(i) requires a manually-operated, fire-alarm system. This system must be supplemented by call-points to notify the local fire authority. The activation mechanism of the manual call-point may also activate the alarm system. This will provide an additional audible warning to the automatic systems required by E2.2.

Where an external alarm is installed, sub-zero temperatures must not freeze its mechanism.

Hydrants—G4.8(a)(ii)

G4.8(a)(ii) requires that hydrants be installed in all the nominated buildings in accordance with E1.3(b). A fire hydrant must be operable in sub-zero conditions, and any water in the mains should not freeze.

Hose reels—G4.8(a)(iii)

G4.8(a)(iii) requires that hose reels be installed in all the nominated buildings in accordance with E1.4, except that E1.4(b), E1.4(c)(ii) and E1.4(f) are modified for Class 2 and 3 buildings.

- G4.8(a)(iii)(A)(aa)—Fire hose reels are required to be installed, irrespective of whether fire hydrants are required, if fire compartments exceed 500 m². For the purpose of a Class 2 or 3 building, a sole-occupancy unit is considered a fire compartment.
- G4.8(a)(iii)(A)(bb)—Generally, fire hose reels are required to be installed on the storey they are to service. In the case of Class 2 or 3 buildings, a concession is provided when a sole-occupancy unit occupies more than one storey if the fire hose reel is located at the level egress from that sole-occupancy unit. There is no limitation on the size or number of storeys within the sole-occupancy unit served by the hose.
- G4.8(a)(iii)(A)(cc)—Doors to sole-occupancy units of Class 2 or 3 buildings may remain open for the hose to pass through. To require a fire hose reel in each sole-occupancy unit could be impractical, therefore fire hose reels are allowed to be placed in a common area and then pass through the entrance door to the unit.

Ancillary provisions

A fire hose reel must be operable in sub-zero conditions, and any water in the mains should not freeze.

Class 4 parts of buildings

G4.8 has not been applied to Class 4 parts of a building. It is extremely unlikely that any of the services and equipment required by G4.8 will be located within a sole-occupancy unit in any residential building. In, for example, Class 2 and Class 3 buildings it is most likely that such services and equipment will be located in common areas.

The requirement for the installation of fire-fighting services and equipment in the non-Class 4 parts of the building within which the Class 4 part is located, will provide for the safety of the occupants of the Class 4 part.

Electricity network substations

G4.8(b) provides an exemption to the requirements for fire hose reels for electricity network substations.

G4.9 Fire orders

Intent

To enable occupants to evacuate a building in an alpine area in an emergency without being impeded by lack of knowledge of the fire safety system, egress routes or evacuation procedures.

Notices

In Class 2, Class 3 and Class 9 buildings, G4.9 requires that a notice containing fire orders be displayed. They are necessary because there is a high probability that, in alpine areas, the occupants may be residing overnight or for short periods only, and will be unfamiliar with their surroundings.

Fire escape information needs to be displayed prominently near the main entrance and on each storey so that people new to the building can identify escape features, etc. A suitable location would be near the primary stairway. Additional advice on locating these items can be obtained from the appropriate authority or local fire authority.

Information must be conveyed in a clear and simple manner, because of the varying degree of technical understanding of people reading this information.

Class 4 parts of buildings

Class 4 parts of buildings have not been included in the coverage of G4.9 because buildings will not typically be used for short term rental accommodation in alpine areas. Therefore, residents are likely to be aware of safety requirements.

Part G5 Construction in bushfire prone areas

Objective

GO5

The Objective of this Part is to—

- (a) safeguard occupants from injury; and
- (b) protect buildings, from the effects of a bushfire.

Application

GO5 only applies to—

- (a) a Class 2 or 3 building; or
- (a) a Class 10a building or deck associated with a Class 2 or 3 building, located in a designated bushfire prone area.

Australia contains some of the most dangerous bushfire areas in the world and concern over loss of life and property led to the development of Part G5.

Within Volume One of the BCA the provisions only apply to a Class 2 or Class 3 building, or a Class 10a building or deck associated with a Class 2 or 3 building, as residential buildings are considered to present the greatest risk to life. The provisions also only apply in areas that have been designated as ‘bushfire prone areas’.

GO5, specifically GO5(b), is one of the few Objectives of the BCA which requires the protection of a building as well as its occupants.

Functional Statements

GF5.1

A building constructed in a designated bushfire prone area is to provide a resistance to bushfires in order to reduce the danger to life and minimise the risk of the loss of the building.

Application

GF5.1 only applies to—

- (a) a Class 2 or 3 building; or
- (a) a Class 10a building or deck associated with a Class 2 or 3 building, located in a designated bushfire prone area.

As for GO5, GF5.1 only applies to a Class 2 or Class 3 building, or a Class 10a building or deck associated with a Class 2 or 3 building in a designated bushfire prone area. However GF5.1 only requires a Class 2 or Class 3 building, or a Class 10a building or deck associated with a Class 2 or 3 building to provide resistance to a bushfire, not total protection.

Performance Requirements

GP5.1 Bushfire resistance

GP5.1 applies only to a Class 2 or Class 3 building, or a Class 10a building or deck associated with a Class 2 or 3 building in a designated bushfire prone area.

The basis of GP5.1 is that:

- bushfires provide a major risk of ignition to a building that may be caused by burning embers, radiant heat and flame; and
- the design and construction measures required to deal with this risk is associated with the mechanism of attack and its intensity.

Ancillary provisions

GV5 Buildings in bushfire prone areas

GV5 is a means to verify the appropriate risk of ignition from a bushfire in order to meet the requirements of **GP5.1**. For further guidance, refer to the ABCB Buildings in Bushfire Prone Areas Verification Method Handbook.

Part G5 Construction in bushfire prone areas

Deemed-to-Satisfy Provisions

G5.0 Deemed-to-Satisfy Provisions

Intent

To clarify that complying with [G5.1](#) and [G5.2](#) will satisfy the requirements of [GP5.1](#).

G5.1 Application of Part

Intent

To clarify that [Part G5](#) applies only to a Class 2 or Class 3 building, or a Class 10a building or deck associated with a Class 2 or 3 building in a designated bushfire prone area.

G5.2 Protection

Intent

To clarify that compliance with AS 3959 will achieve compliance with [Part G5](#).

[G5.2](#) adopts AS 3959—*Construction of buildings in bushfire-prone areas*. Compliance with this Australian Standard will achieve compliance with [Part G5](#).

The purpose of AS 3959 is to improve the fire resistance performance of buildings that may be subjected to burning debris, radiant heat and flame contact during the passing of a fire front. Construction requirements are dependent on the bushfire hazard level of the site. It should be noted that even though a site may be located in a designated bushfire prone area, if the category of bushfire attack for the particular site is low, there are no special construction requirements specified in AS 3959.

Maintenance plays an important role in the overall strategy of improving the performance of buildings against bushfires. This includes maintenance (or better still, improvement) of the site conditions and maintenance of the building itself.

Part G6 **Occupiable outdoor areas**

Objective**Functional Statements****Performance Requirements**

The Objectives and Functional Statements for [Part G6](#) are contained in [Sections C, D, E, F and G](#) of this Guide. The Performance Requirements for [Part G6](#) are contained in [Sections C, D, E, F and G](#). [Part G6](#) contains Deemed-to-Satisfy Provisions for occupiable outdoor areas in addition to those contained in [Sections C, D, E, F and G](#).

A number of the Deemed-to-Satisfy Provisions in [Part G6](#) qualify the application of the corresponding Deemed-to-Satisfy Provisions contained in [Sections C, D, E, F and G](#) which are considered necessary for occupiable outdoor areas.

Specific comments regarding [Specification C1.1](#) (fire-resisting construction provisions) and [Specification E2.2a](#) (smoke hazard management provisions) are found in those sections of this Guide.

Part G6 Occupiable outdoor areas

Deemed-to-Satisfy Provisions

G6.1 Application of Part

Intent

To clarify that [Part G6](#) applies only to buildings containing an occupiable outdoor area and its provisions override [Sections C, D, E, F and G](#) of the BCA if there is a difference.

[G6.1\(a\)](#) indicates that the Deemed-to-Satisfy Provisions of [Part G6](#) apply to buildings containing an occupiable outdoor area. These provisions are additional to other Deemed-to-Satisfy Provisions of the BCA that apply to occupiable outdoor areas, for example the relevant provisions of [Part D3](#) relating to access for people with a disability.

[G6.1\(b\)](#) provides a rule for resolving inconsistencies between the requirements in [Part G6](#) and those in the remainder of the BCA, by providing that the Deemed-to-Satisfy Provisions of [Part G6](#) take precedence where there is a difference.

[G6.1\(c\)](#) requires that certain provisions are not applied to private residential balconies or smaller balconies found in commercial buildings.

G6.2 Fire hazard properties

Intent

To specify fire hazard property requirements for an occupiable outdoor area.

[G6.2](#) is included to ensure that materials and assemblies in occupiable outdoor areas restrict the spread of fire and heat to maintain tenability to permit egress. As a result, the fire hazard properties relating to flammability and flame propagation apply to occupiable outdoor spaces.

A concession has been applied to the smoke hazard management requirements of [C1.10](#) because occupiable outdoor spaces, being unenclosed, are unlikely to be affected by a build-up of smoke.

G6.3 Separation of classifications

Intent

To specify fire-resistance and separation requirements for an occupiable outdoor area.

An occupiable outdoor area may have a different classification to other parts of the building located alongside it or on an adjacent level. Further, an occupiable outdoor area may be fire-separated from other parts of a building. [G6.3](#) therefore applies the requirements of [C2.7](#), [C2.8](#) and [C2.9](#) to occupiable outdoor areas.

G6.4 Provision for escape

Intent

To specify requirements to allow occupants to escape from an occupiable outdoor area in the event of an emergency.

[G6.4](#) is included to ensure that requirements which allow occupants to escape are applied to occupiable outdoor areas as for an internal, occupied part of the building. [G6.4](#) in addition clarifies that a reference to a storey or room includes an occupiable outdoor area. This may require the inclusion of a fire-isolated exit stair for a building that would otherwise not require one if it did not have a rooftop occupiable outdoor area.

This is in recognition that occupants of an occupiable outdoor area are constrained by the building, and therefore require a means of evacuation in an emergency.

Consequently, the provisions from [Part D1](#) as applied under [G6.4](#) are considered the minimum necessary to enable safe egress.

Ancillary provisions

G6.5 Construction of exits**Intent**

To specify requirements for the construction of exits in an occupiable outdoor area.

G6.5 is included to ensure that requirements for the construction of exits are applied to an occupiable outdoor area and clarifies that a reference to a storey or room (for example, as found in **D2.21(c)**) includes an occupiable outdoor area.

G6.6 Fire fighting equipment**Intent**

To specify requirements for fire fighting equipment in an occupiable outdoor area.

G6.6 outlines the appropriate requirements for fire fighting equipment for an occupiable outdoor area and clarifies that a reference to a storey includes an occupiable outdoor area. This is in recognition that an occupiable outdoor area is considered to represent a level of hazard that justifies the installation of fire fighting equipment.

G6.6 contains an exclusion for **Clause 7(b)(i)** of **Specification E1.5** to enable a building containing an occupiable outdoor area at its roof level to have a storage tank for a sprinkler system located in the level below.

G6.7 Lift installations**Intent**

To specify requirements for lift installations in an occupiable outdoor area.

G6.7 outlines that an occupiable outdoor area is considered as a storey for the purposes of **Part E3**.

This requirement ensures, among other things, that where an emergency lift is installed it serves an occupiable outdoor area.

G6.8 Visibility in an emergency, exit signs and warning systems**Intent**

To specify requirements to minimise the risk of death or injury to occupants during an emergency because of—

- an inability to see their way along an exit path of travel; and
- an inability to find an exit; and
- a lack of knowledge that an emergency exists or an evacuation is required.

The effect of **G6.8** is to apply the requirements of **Part E4** to occupiable outdoor areas as for an internal, occupied part of the building.

Consequently, the provisions from **Part E4** as applied under **G6.8** are considered the minimum necessary to enable safe evacuation of occupants in case of an emergency.

G6.9 Light and ventilation**Intent**

To specify requirements for light and ventilation in an occupiable outdoor area.

There are a wide variety of occupiable outdoor areas. **G6.9** is provided in recognition that various occupiable outdoor areas may have periods of occupation that require the provision of artificial lighting.

In addition, **G6.9** applies the restrictions for sanitary facilities found in **F4.8** and **F4.9** to those directly adjoining occupiable outdoor areas.

G6.10 Fire orders**Intent**

To enable occupants to evacuate an occupiable outdoor area in an alpine area in an emergency without being impeded

Ancillary provisions

by lack of knowledge of the fire safety system, egress routes or evacuation procedures.

[G6.10](#) ensures that an occupiable outdoor area is considered as a storey for the purposes of [G4.9](#). Where a building is located in an alpine area and contains an occupiable outdoor area, it is important that the fire orders are displayed in a suitable location.

Special use buildings

- Part H1** **Class 9b buildings**
- Part H2** **Public transport buildings**
- Part H3** **Farm buildings and farm sheds**

Section H Special use buildings

Part H1 Class 9b buildings

Objective

Functional Statements

Performance Requirements

Deemed-to-Satisfy Provisions

H1.1 Application of Part

H1.2 Separation

H1.3 Proscenium wall construction

H1.4 Seating area

H1.5 Exits from stages

H1.6 Access to platforms and lofts

H1.7 Aisle lights

Part H2 Public transport buildings

Objective

Functional Statements

Performance Requirements

Deemed-to-Satisfy Provisions

H2.1 Application of Part

H2.2 Accessways

H2.3 Ramps

H2.4 Handrails and grabrails

H2.5 Doorways and doors

H2.6 Lifts

H2.7 Stairways

H2.8 Unisex accessible toilet

H2.9 Location of accessible toilets

H2.10 Symbols and signs

H2.11 Tactile ground surface indicators

H2.12 Lighting

H2.13 Hearing augmentation

H2.14 Emergency warning systems

H2.15 Controls

Part H3 Farm buildings and farm sheds

Objective

Functional Statements

Performance Requirements

Deemed-to-Satisfy Provisions

H3.1 Application of Part

H3.2 Fire resistance and separation

H3.3 Provision for escape

H3.4 Construction of exits

H3.5 Fixed platforms, walkways, stairways and ladders

H3.6 Thresholds

H3.7 Swinging doors

H3.8 Fire fighting equipment

H3.9 Fire hydrants and water supplies

H3.10 Fire hose reels

H3.11 Portable fire extinguishers

H3.12 Emergency lighting requirements

- H3.13 Exit signs
- H3.14 Direction signs
- H3.15 Design and operation of exit signs
- H3.16 Sanitary facilities
- H3.17 Height of rooms and other spaces
- H3.18 Artificial lighting

Specification H1.3 Construction of proscenium walls
Deemed-to-Satisfy Provisions

Part H1 Class 9b buildings**Objective****Functional Statements****Performance Requirements**

The Objectives and Functional Statements for [Part H1](#) are contained in [Sections C, D](#) and [E](#) of this Guide. The Performance Requirements for [Part H1](#) are contained in [Sections C, D](#) and [E](#). [Part H1](#) contains additional Deemed-to-Satisfy Provisions for Class 9b buildings.

Part H1 Class 9b buildings

Deemed-to-Satisfy Provisions

H1.1 Application of Part

Intent

To clarify which Class 9b buildings are subject to [Part H1](#), and to what extent they are subject.

Class 9b buildings and high fire loads—[H1.1\(a\)](#)

Stages used for live performances can contain high fire loads due to the props, scenery, lighting, and the like used in such productions. Such props and scenery are often also stored in backstage areas, which adds to the fire load.

General application of [Part H1](#)

In general, [Part H1](#) applies to specified enclosed Class 9b buildings which:

- in the case of school assembly, church or community halls, contain both a stage and backstage area which exceeds 300 m²;
- are not covered by [H1.1\(a\)\(i\)](#), and have a stage and backstage area which exceeds 200 m²; or
- have a stage with a rigging loft.

[Part H1](#) does not simply apply to stage and backstage areas, but also to seating areas and aisle lighting.

[H1.4](#) and all Class 9b buildings—[H1.1\(b\)\(i\)](#)

[H1.4](#) applies to all Class 9b buildings, whether or not they are enclosed, and regardless of size.

[H1.7](#) and all enclosed Class 9b buildings—[H1.1\(b\)\(ii\)](#)

[H1.7](#) applies to all Class 9b buildings which are enclosed, regardless of their size.

H1.2 Separation

Intent

To protect the audience in a theatre or public hall from a fire on the stage.

Fire safety

[H1.2](#) does not apply to all theatres and public halls. See [H1.1](#) to determine which buildings need to comply with [H1.2](#). A stage and backstage area of a theatre or public hall has a high fire load due to the storage of props and scenery/etc.

The audience must be protected from this fire source by either:

- the installation of a sprinkler system (other than a FPAA101D or FPAA101H system); or
- the construction of a proscenium wall between the stage and the audience area.

H1.3 Proscenium wall construction

Intent

To set out the detailed construction requirements for a proscenium wall.

Proscenium wall—[Specification H1.3](#)

The construction details for a proscenium wall are contained in [Specification H1.3](#).

H1.4 Seating area

Intent

To enable the evacuation of an audience from the seating area.

[H1.4](#) applies to all Class 9b buildings

Under [H1.1\(b\)\(i\)](#), [H1.4](#) applies to all Class 9b buildings, both enclosed and open. This means that it applies to theatres,

Special use buildings

open-deck spectator stands, sporting stadiums, and the like, wherever the public is seated to view an event.

Maximum slope of the floor—H1.4(a)

H1.4(a) deals with the height difference between the floors supporting seats in a theatre and the like. The maximum slope of the floor of 1 in 8 is consistent with D2.10(b)(ii).

This slope cannot be used in aisles required to be accessible by people with disabilities. In such a case, the maximum slope of the aisle is 1 in 14, as required by AS 1428.1.

Height of openings in steps

The maximum gap of 125 mm stipulated in H1.4(a)(iii) is consistent with D2.13(a)(iv).

Figure H1.4(1) and (2)

Figure H1.4(1) and (2) illustrate methods of complying with H1.4(a) and (b).

Figure H1.4(1) Method of compliance with H1.4(b) if difference between levels is 230-400 mm

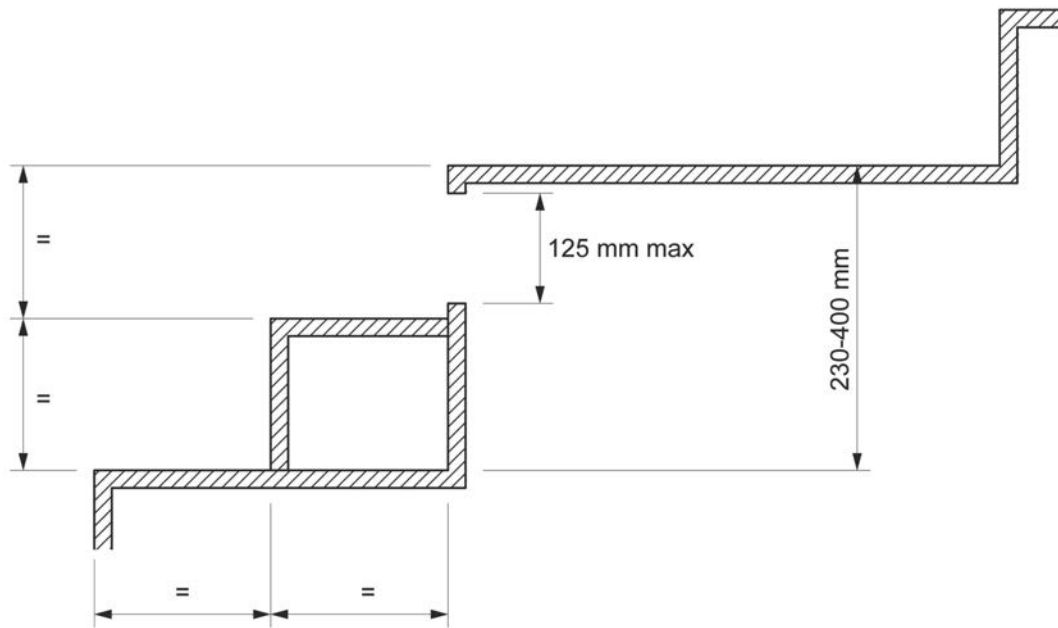

Width of path of travel to an exit—H1.4(c)

It is often impractical to require the standard minimum width of a path of travel to an exit of one metre between rows of fixed seating. H1.4(c) allows a reduced width in such cases. This width is based on studies of movement between rows.

Distance between the seats should ordinarily be measured:

- with the seat in the up position if folding seats are used; or
- directly between the seats, as shown in Figure H1.4(3).

Special use buildings

Figure H1.4(2) Method of compliance with H1.4(b) if difference between levels is 400-600 mm

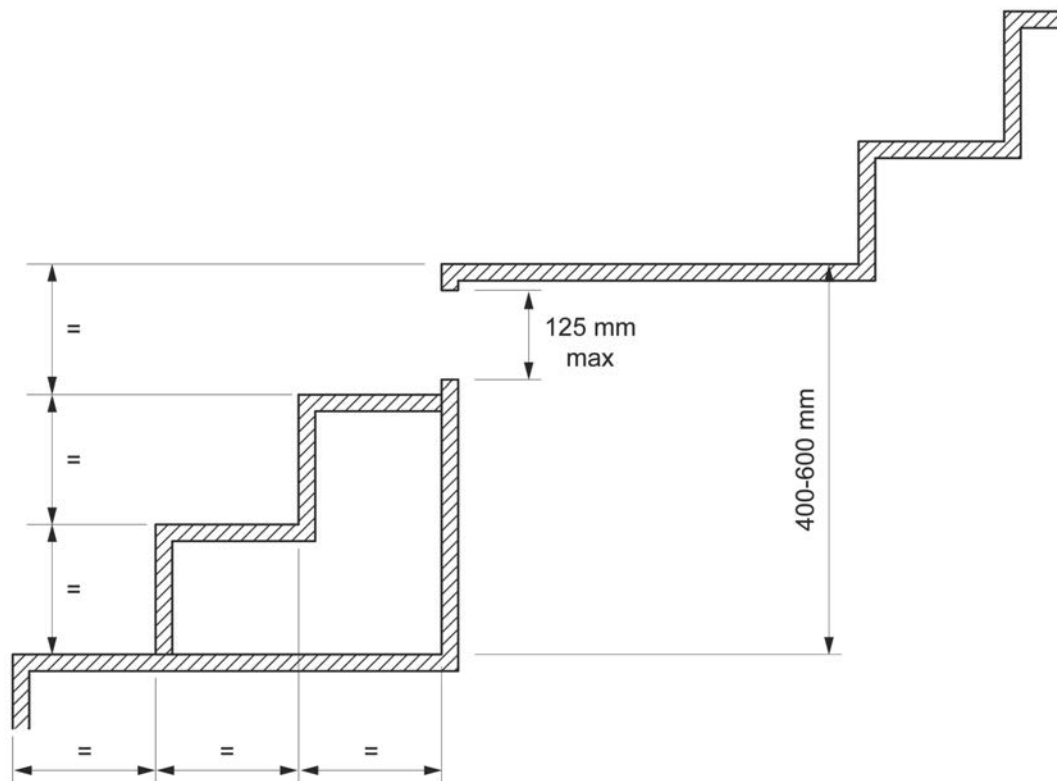

H1.4(c) applies only where the public is seated on fixed seating to view an event.

H1.5 Exits from stages

Intent

To enable safe egress from the stage and backstage areas of a theatre.

Evacuation routes from stage and backstage areas

A stage and backstage area of a theatre or public hall has a high fire load. It is also a potential fire source due to stored props, scenery, lighting, special effects, and the like.

Because of the recognised fire hazard, proscenium walls and curtains are required to separate the stage and backstage areas from the audience.

To maintain this fire separation:

- an evacuation route from the stage side of a proscenium must not pass through the proscenium; and
- required exits from backstage must be independent of the audience evacuation routes.

H1.6 Access to platforms and lofts

Intent

To set out the requirements for stairways to service platforms, rigging lofts, and the like.

Stairways to service platforms and rigging lofts

Stairways to service platforms, rigging lofts, and the like must comply with AS 1657.

H1.7 Aisle lights

Intent

To make safe evacuation available from theatres.

Special use buildings

Aisle lights

H1.7 applies to enclosed Class 9b buildings where:

- lighting is dimmed or extinguished during public occupation; and
- the floor is stepped or inclined at a slope steeper than 1 in 12.

In case of an evacuation, and when the lights are dimmed or extinguished during a performance, H1.7 requires the installation of aisle lights to avoid people tripping on steps, or falling on a ramp.

Figure H1.4(3) Method of measurement of clearance between rows of fixed seating

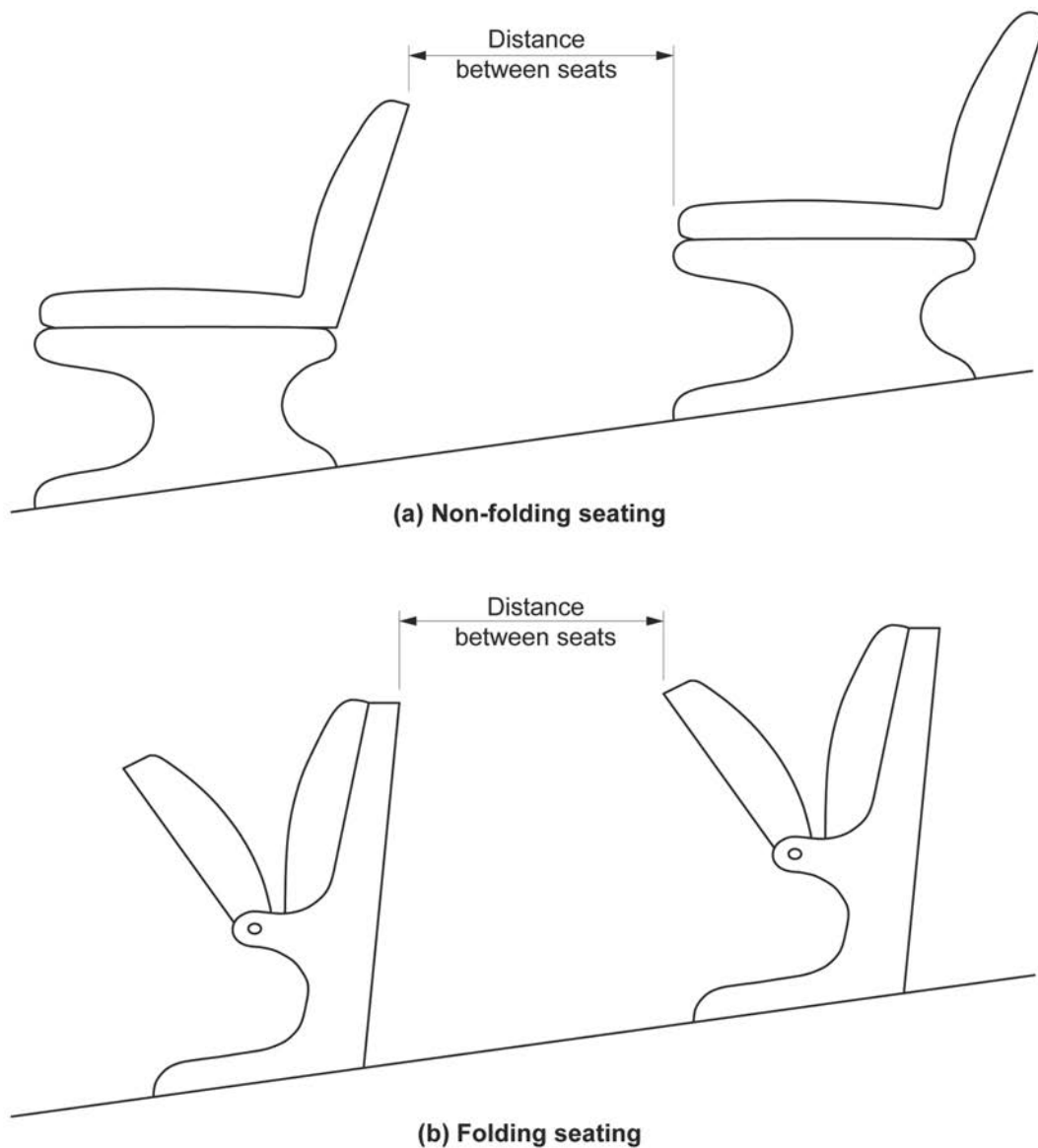

Part H2 Public transport buildings

Objective**Functional Statements****Performance Requirements**

The Objectives and Functional Statements for [Part H2](#) are contained in Sections [D](#), [E](#) and [F](#) of this Guide. The Performance Requirements for [Part H2](#) are contained in [Sections D](#), [E](#) and [F](#). [Part H2](#) contains Deemed-to-Satisfy Provisions for Class 9b and Class 10 public transport buildings additional to those contained in [Parts D3](#), [E3](#) and [F2](#) that apply to public transport buildings.

Part H2 Public transport buildings

Deemed-to-Satisfy Provisions

H2.1 Application of Part

Intent

To clarify which public transport buildings are subject to [Part H2](#) and to what extent they are subject.

[Part H2](#) specifically relates to buildings associated with public transport services, such as railway stations, bus interchanges, airports and ferry terminals. These requirements were previously located in the Disability Standards for Accessible Public Transport 2002 (Transport Standards). Some versions of Australian Standards referred to in [Part H2](#) may be different to those referred to in the remainder of the BCA. The correct version of the Australian Standard to be used can be determined by reference to [Schedule 4](#).

[H2.1\(a\)](#) provides that the Deemed-to-Satisfy Provisions of [Part H2](#) apply to the passenger use areas of Class 9b or Class 10 buildings used for public transport. Class 9b and Class 10 public transport buildings must also satisfy the Deemed-to-Satisfy Provisions of [Parts D3](#), [E3](#) and [F2](#).

[H2.1\(b\)](#) provides a rule for resolving inconsistencies between these requirements imposed on public transport buildings by providing that the Deemed-to-Satisfy Provisions of [Part H2](#) take precedence where there is a difference.

[H2.1\(c\)](#) provides that, as under the Transport Standards, certain requirements in [Part H2](#) do not apply to 'airports that do not accept regular public transport services' as defined in the Transport Standards.

[H2.1\(d\)](#) provides that exemption 1 to [A6.0](#) does not apply to [Part H2](#) because the application of this provision to [Part H2](#) could result in a different outcome to what would have been achieved under similar provisions that existed in the Transport Standards. Under exemption 1 to [A6.0](#), if 10% or less of the floor area of a storey is used for a purpose which could be classified differently to the remainder of that storey, that part may be classified as being the same as the remainder.

H2.2 Accessways

Intent

To specify requirements for accessways in buildings covered by [Part H2](#).

The requirements for accessways in [H2.2](#) were previously located in the Transport Standards.

Accessways and manoeuvring areas may be for other purposes, such as standing areas, but it is expected that public transport passengers will be able to transit them and that they remain available for use by people with a disability when required.

Hazards created by poles, columns, stanchions, bollards and fixtures alongside accessways should be avoided. For example, the use of short posts to prevent delivery vehicles from driving onto parts of pedestrian areas, or commercial signs projecting from walls should be avoided.

[H2.2\(g\)](#) requires passing areas to be provided in prescribed locations, with the intent that they be wide enough for 2 people, each using a mobility aid, to pass one another.

H2.3 Ramps

Intent

To specify requirements for ramps in buildings covered by [Part H2](#).

The requirements for ramps in [H2.3](#) were previously located in the Transport Standards.

[H2.3](#) provides requirements for accessible ramps in public transport buildings. Ramps forming part of an accessway must comply with clause 8 of AS 1428.2.

[H2.3\(b\)](#) provides that [D3.11\(a\)](#), which limits the combined vertical rise of connected ramps to 3.6 m, does not apply to buildings covered by [Part H2](#).

Special use buildings

H2.4 Handrails and grabrails

Intent

To specify requirements for handrails and grabrails in buildings covered by [Part H2](#).

The requirements for handrails and grabrails in [H2.4](#) were previously located in the Transport Standards.

[H2.4](#) provides requirements for handrails and grabrails in public transport buildings. [H2.4\(b\)](#) provides that handrails must be placed along an accessway to assist wherever passengers are likely to require additional support or guidance, such as changes of level, ramps, a narrowing or a change of direction of an accessway. [H2.4\(d\)](#) provides, in particular, that a grabrail or handrail must be provided at fixed locations where passengers are required to pay fares.

H2.5 Doorways and doors

Intent

To specify requirements for doorways and doors in buildings covered by [Part H2](#).

The requirements for doorways and doors in [H2.5](#) were previously located in the Transport Standards.

[H2.5](#) provides that doorways and doors must comply with clause 11 (except clause 11.5.2) of AS 1428.2. The BCA allows for doors that are automatic, power assisted or manual.

H2.6 Lifts

Intent

To specify requirements for lifts in buildings covered by [Part H2](#).

The requirements for lifts in [H2.6](#) were previously located in the Transport Standards.

[H2.6](#) provides that lift facilities must comply with AS 1735.12.

H2.7 Stairways

Intent

To specify requirements for stairways in buildings covered by [Part H2](#).

The requirements for stairways in [H2.7](#) were previously located in the Transport Standards.

[H2.7](#) provides specifications for accessible stairways in public transport buildings.

The requirement for an accessway under the BCA means that stairways cannot be the sole means of access. However, stairways are acceptable as an optional route on an accessway.

H2.8 Unisex accessible toilet

Intent

To specify requirements for unisex accessible toilets in buildings covered by [Part H2](#).

The requirements for unisex accessible toilets in [H2.8](#) were previously located in the Transport Standards.

[H2.8](#) provides that if toilets are provided, at least one unisex accessible toilet must be provided in accordance with AS 1428.1 (2001) clause 10, sanitary facilities.

H2.9 Location of accessible toilets

Intent

To specify requirements for the location of accessible toilets in buildings covered by [Part H2](#).

The requirements for the location of accessible toilets in [H2.9](#) were previously located in the Transport Standards.

[H2.9](#) provides that accessible toilets must be provided in the same location as other toilets.

H2.10 Symbols and signs

Intent

To specify requirements for symbols and signs in buildings covered by [Part H2](#).

The requirements for symbols and signs in [H2.10](#) were previously located in the Transport Standards.

[H2.10](#) provides requirements for symbols and signs, including where signs should be provided, and the specifications that the signs must comply with.

H2.11 Tactile ground surface indicators

Intent

To specify requirements for tactile ground surface indicators (TGSIs) in buildings covered by [Part H2](#).

The requirements for TGSIs in [H2.11](#) were previously located in the Transport Standards.

[H2.11](#) provides that TGSIs must be installed to define key areas on an accessway for people with vision impairment. TGSIs must comply with AS 1428.4 and must indicate changes in direction in accordance with clause 18.1 of AS 1428.2.

H2.12 Lighting

Intent

To specify requirements for lighting in buildings covered by [Part H2](#).

The requirements for lighting in [H2.12](#) were previously located in the Transport Standards.

[H2.12](#) provides that any lighting provided must comply with the minimum levels of maintenance illumination specified in the notes to clause 19.1 of AS 1428.2.

H2.13 Hearing augmentation

Intent

To specify requirements for hearing augmentation in buildings covered by [Part H2](#).

The requirements for hearing augmentation in [H2.13](#) were previously located in the Transport Standards.

[H2.13](#) provides that if a public address system is installed, it must comply with clause 21.1 of AS 1428.2.

H2.14 Emergency warning systems

Intent

To specify requirements for emergency warning systems in buildings covered by [Part H2](#).

The requirements for emergency warning systems in [H2.14](#) were previously located in the Transport Standards.

[H2.14](#) provides specifications for emergency warning systems. [H2.14\(b\)](#) provides that, in the event of an emergency, provision must be made for people with vision impairment to locate the exit path.

H2.15 Controls

Intent

To specify requirements for controls in buildings covered by [Part H2](#).

The requirements for controls in [H2.15](#) were previously located in the Transport Standards.

[H2.15](#) provides that controls must comply with clause 11 of AS 1428.1 which covers door handles and hardware, switches and general purpose outlets (power points) and water taps.

Part H3 Farm buildings and farm sheds

Objective**Functional Statements****Performance Requirements**

The Objectives and Functional Statements for [Part H3](#) are contained in [Sections C, D, E and F](#) of this Guide. The Performance Requirements for [Part H3](#) are contained in [Section C, D, E and F](#). [Part H3](#) contains Deemed-to-Satisfy Provisions for farm buildings and farm sheds in addition to those contained in [Section C, D, E and F](#). A number of the Deemed-to-Satisfy Provisions in [Part H3](#) offer concessions for farm buildings and farm sheds from the corresponding Deemed-to-Satisfy Provisions contained in [Section C, D, E and F](#).

Part H3 Farm buildings and farm sheds

Deemed-to-Satisfy Provisions

H3.1 Application of Part

Intent

To clarify the application of [Part H3](#) to farm buildings and farm sheds and to clarify to what extent they are subject.

General application of [Part H3](#)

[H3.1\(a\)](#) outlines that the Deemed-to-Satisfy Provisions of [Part H3](#) apply to farm buildings and farm sheds.

[H3.1\(b\)](#) provides a rule for resolving inconsistencies between these requirements imposed on farm buildings and farm sheds and those in the remainder of the BCA, by providing that the Deemed-to-Satisfy Provisions of [Part H3](#) take precedence where there is a difference.

Farm buildings and farm sheds in [Part H3](#)

[H3.1\(c\)](#) sets out which provisions in [Part H3](#) apply to farm sheds.

[H3.1\(d\)](#) sets out which provisions in [Part H3](#) apply to farm buildings.

H3.2 Fire resistance and separation

Intent

To specify fire resistance and separation requirements for farm sheds.

[H3.2](#) provides a concession for farm sheds (see defined term) from the Deemed-to-Satisfy requirements in [Parts C1](#), [C2](#) and [C3](#), except for [C1.11](#).

This concession recognises that these buildings will only be occupied by a few people at any time, who are likely to know the building well, thus reducing the risk to life safety. In the event of an emergency in a farm shed, such as a fire, it is expected any occupants will be able to evacuate quickly as there are exits provided.

Further to this, the building elements of a farm shed do not need to be protected from the spread of fire because it is likely there is only one fire compartment, people are not sleeping in the building and there is little likelihood that a fire will spread to another building due to the separation distance required.

H3.3 Provision for escape

Intent

To specify requirements to allow occupants to escape from a farm shed in the event of an emergency.

The intent of [H3.3](#) is to ensure that the requirements to allow occupants to escape are proportional and appropriate to the very limited number of occupants anticipated in the building at any time. Consequently, the specific provisions from [Part D1](#) which are listed in [H3.3\(a\)](#) are considered the minimum necessary for farm sheds to achieve this objective.

[H3.3\(b\)](#) provides a further concession for farm sheds and farm buildings so that an open space (see definition) need not be directly connected to a public road. This concession gives recognition to the often isolated nature of many farm sheds and farm buildings.

H3.4 Construction of exits

Intent

To specify requirements for the construction of exits in a farm shed.

The intent of [H3.4](#) is to ensure that the specific requirements for the construction of exits are proportional and appropriate to the very limited number of occupants anticipated in the building at any time. It is likely that any occupants will be familiar with the building, and therefore, will be able to quickly identify exits and traverse obstacles in order to gain quick and efficient egress in case of an emergency. Consequently, the specific provisions from [Part D2](#) which are listed in [H3.4](#) are considered the minimum necessary for farm sheds to achieve this objective.

Special use buildings

H3.5 Fixed platforms, walkways, stairways and ladders**Intent**

To provide requirements for the construction of fixed platforms, walkways, stairways and ladders in farm buildings and farm sheds.

[H3.5](#) extends the concession contained in [D2.18](#) to farm buildings and farm sheds, to allow a choice of designing a stairway, platform, etc. to the requirements contained in [D2.13](#), [D2.14](#), [D2.16](#) and [D2.17](#) or within AS 1657.

H3.6 Thresholds**Intent**

To provide a concession for farm buildings, under certain conditions, from complying with the requirements of [D2.15](#).

Doorways to farm buildings and farm sheds are often provided with a threshold (more commonly known as a hob or vermin barrier) in the form of a low-height concrete wall along the sides of the building for the purposes of cleaning, clearing and pest control. This is particularly relevant to buildings used for keeping pigs and chickens.

These thresholds do not comply with the Deemed-to-Satisfy Provisions of [D2.15](#) which generally prevent a step or ramp being constructed at the doorway. [H3.6](#) provides a concession for a farm building or farm shed enabling the construction of a hob up to 700 mm in height, except where the area is required to be accessible by [D3.1](#).

H3.7 Swinging doors**Intent**

To provide a concession for farm buildings from complying with the requirements of [D2.20](#).

[H3.7](#) specifies that [D2.20](#) does not apply to a farm building. [D2.20](#) also does not apply to a farm shed due to [H3.4](#).

H3.8 Fire fighting equipment**Intent**

To provide a concession for farm sheds from complying with the requirements of [Part E1](#).

Due to the limited size and very low occupation of farm sheds, the provision of fire hydrants, fire hose reels and sprinklers is considered onerous for these types of buildings as a minimum requirement.

This concession aims to allow what is considered as an appropriate level of fire fighting equipment to facilitate initial attack by any occupants, in the form of portable fire extinguishers in specific locations. Refer to [H3.11](#) for the portable fire extinguisher requirements for farm sheds.

H3.9 Fire hydrants and water supplies**Intent**

To provide appropriate fire fighting and water supply requirements for farm buildings.

Farm buildings are often located in remote areas which are not serviced by mains water, and these areas can also be affected by drought which can affect the availability and reliability of on-site water supply. To ensure a farm building has adequate water to allow an attending fire brigade to undertake fire fighting operations and in light of the limited availability of water when compared to more urban located buildings, [H3.9\(a\)\(iii\)](#) provides a concession to the requirements of AS 2419.1 so that 2 hours water supply for a fire hydrant installation is required instead of 4 hours.

[H3.9\(a\)\(iv\)](#) provides an alternative concession, if certain conditions are met, from the requirement for a fire hydrant system to be installed to serve a farm building. The concession instead requires the provision of an adequate supply of water that can be used by a fire brigade instead of a fire hydrant system, noting that there is also a reduction in the volume of static water required to be supplied for fire fighting purposes from 288,000 litres to 144,000 litres.

Acceptable sources of water are listed in [\(b\)\(i\)](#) to [\(vii\)](#) and must be located on the same allotment as the farm building, have a minimum capacity of 144,000 litres, and access to the water supply must be within 60 to 90 metres from any part of the farm building. The water source must also be situated so as to enable emergency services vehicles access to within 4 metres. Multiple buildings may be served by a single water supply providing the proximity requirements of [H3.9\(a\)\(iv\)](#)

Special use buildings

are met by each building.

If a water supply is a water tank, there are additional requirements such as suitable suction connections to ensure that the fire brigade can access and use the water available in the water tank.

H3.10 Fire hose reels

Intent

To provide a concession for farm buildings, under certain conditions, from complying with the requirements of [E1.4](#).

Due to the low occupancy numbers of farm buildings, these buildings are exempt from the requirements for fire hose reels where specific requirements for portable fire extinguishers are satisfied under [H3.11](#).

Farm sheds are not required to comply with the requirements of [E1.4](#) due to [H3.8](#).

H3.11 Portable fire extinguishers

Intent

To specify requirements for portable fire extinguishers in farm buildings and farm sheds covered by [H3](#).

Portable fire extinguishers in buildings allow occupants to undertake initial attack on a fire. They should be located in plain view, along normal paths of travel and near exits where possible, and should not be located in hazardous places. Under [E1.6](#), portable fire extinguishers must be provided in accordance with [Table E1.6](#), which refers to AS 2444 Portable fire extinguishers and fire blankets – Selection and location.

[H3.11](#) includes requirements for specific types of extinguishers to be installed to deal with the specific types of hazards which may be associated with farm buildings and farm sheds. When applying [H3.11\(a\)\(i\)](#) the proposed building use should be considered. In addition, there are requirements to ensure that occupants are aware of the location of portable fire extinguishers as [H3.11](#) includes reference to specific sections of AS 2444.

H3.12 Emergency lighting requirements

Intent

To provide a concession for farm buildings and farm sheds, under certain conditions, from complying with the requirements of [E4.2](#).

[H3.12](#) contains a concession from the requirements in [E4.2](#) to provide an emergency lighting system in a farm building, in specific circumstances. For a farm building, [H3.12\(a\)](#) outlines concessions where:

- there is no artificial lighting provided in accordance with [H3.18](#); or
- a farm building is connected to a back-up generator system that will likely ensure sufficient light is automatically provided in the event of a power failure.

[H3.12\(b\)](#) outlines that a farm shed need not be provided with an emergency lighting system due to the very limited occupancy of these buildings.

H3.13 Exit signs

Intent

To provide a concession for farm sheds, under certain conditions, from complying with the requirements of [E4.5](#).

[H3.13](#) provides a concession for farm sheds from the requirements of [E4.5](#) in the circumstance where there is a large permanent opening, on the basis that where farm sheds are likely only to be occupied during the day there would be sufficient natural light available from a permanent opening to guide any occupants towards the exit.

H3.14 Direction signs

Intent

To specify requirements for the provision of direction signs in farm buildings and farm sheds.

[H3.14](#) outlines requirements for direction signs in farm buildings and farm sheds, to enable occupants to find their way out of a building in the event of an emergency.

Special use buildings

H3.15 Design and operation of exit signs**Intent**

To provide a concession for farm buildings and farm sheds, under certain conditions, from complying with the requirements of [E4.8](#).

Some farm animals are sensitive to the level or duration of light to which they are exposed and the use of illuminated exit signs can adversely impact the behaviour or welfare of these animals where they permanently occupy a building. [H3.15\(a\)](#) provides a concession to the requirements of [E4.8](#) for farm buildings to allow non-illuminated exit signs to be used provided the size, mounting height and pictorial requirements of Appendix D of AS/NZS 2293.1 are complied with.

For a farm shed, illuminated exit signs are not considered necessary given the limited size and low occupancy of these buildings and a concession is provided in [H3.13](#). However, required exit signs must meet basic criteria, such as maximum viewing distances, to ensure that occupants can safely evacuate.

H3.16 Sanitary facilities**Intent**

To provide a concession for farm sheds from complying with the requirements of [F2.3](#).

[H3.16](#) provides a concession for farm sheds from compliance with [F2.3](#).

H3.17 Height of rooms and other spaces**Intent**

To provide a concession for farm sheds from complying with the requirements of [F3.1](#).

[H3.17](#) provides a concession for farm sheds from compliance with [F3.1](#).

H3.18 Artificial lighting**Intent**

To provide a concession for farm buildings and farm sheds from complying with the requirements of [F4.4](#).

There are a wide variety of farm buildings. [H3.18\(a\)](#) is provided in recognition of the fact that various farm building uses may negate the requirement for artificial lighting. There are two components in using the concession from [F4.4](#) for farm buildings. The first is ensuring sufficient visibility for safe movement of occupants. Where artificial lighting is not provided, an alternative means of providing sufficient visibility must be demonstrated.

The second component acknowledges that some farm animals are sensitive to the level or duration of light to which they are exposed and the use of artificial lighting can adversely impact the behaviour or welfare of these animals where they permanently occupy a building. Some types of plant and fungi are also sensitive to the level of lighting provided.

[H3.18\(b\)](#) exempts farm sheds from compliance with [F4.4](#).

Specification H1.3

Construction of proscenium walls

Deemed-to-Satisfy Provisions

Specification H1.3—Comments

This Guide does not address, in detail, every provision in this Specification. However, there are some comments which should be made.

Specification H1.3—purpose

A stage and backstage area of a theatre or public hall has a high fire load. It is also a potential fire source due to stored props and scenery, etc.

[Specification H1.3](#) deals with how to provide fire separation by a proscenium wall between the stage and backstage areas, and other parts of the building, including those occupied by an audience.

Height and extent of a proscenium wall—fire wall

The height and extent of a proscenium wall are similar to those of a fire wall. Any openings in it must be suitably protected to prevent the spread of a fire to the audience side.

Proscenium curtains

An important part of avoiding the spread of fire from the stage is the protection of the opening to the stage. Protection must be provided while still permitting the audience to view a performance.

Since the opening is too large to protect with an automatically-closing fire door, the aim of providing protection while maintaining functionality is achieved by the use of a proscenium curtain. [Clause 6](#) of the specification gives two alternative options for such a curtain.

Part I1 * * * * *

Part I2 * * * * *

Section I *****

Part I1 *****

Part I2 *****

Part I1

* * * * *

The content of [Part I1](#), which existed in BCA 2013, has been removed. The Part number [Part I1](#) has been retained without text so as not to change the numbering of the current BCA from that of BCA 2013.

Part I2

* * * * *

The content of [Part I2](#), which existed in BCA 2013, has been removed. The Part number [Part I2](#) has been retained without text so as not to change the numbering of the current BCA from that of BCA 2013.

Energy efficiency

Section J	Energy efficiency
Part J0	Energy efficiency
Part J1	Building fabric
Part J2	* * * * *
Part J3	Building sealing
Part J4	* * * * *
Part J5	Air-conditioning and ventilation systems
Part J6	Artificial lighting and power
Part J7	Heated water supply and swimming pool and spa pool plant
Part J8	Facilities for energy monitoring

Section J Energy efficiency

Section J Energy efficiency

Objective

JO1

Functional Statements

JF1

Performance Requirements

JP1

JP2 * * * * *

JP3 * * * * *

Verification Methods

JV1 NABERS Energy for Offices

JV2 Green Star

JV3 Verification using a reference building

JV4 Building envelope sealing

Specification JVa **Additional requirements**

Specification JVb **Modelling parameters**

Specification JVc **Modelling profiles**

Part J0 Energy efficiency

Deemed-to-Satisfy Provisions

J0.0 Deemed-to-Satisfy Provisions

J0.1 Application of Section J

J0.2 Reducing the heating and cooling loads of a sole-occupancy unit of a Class 2 building or a Class 4 part

J0.3 Ceiling fans

Part J1 Building fabric

Deemed-to-Satisfy Provisions

J1.0 Deemed-to-Satisfy Provisions

J1.1 Application of Part

J1.2 Thermal construction — general

J1.3 Roof and ceiling construction

J1.4 Roof lights

J1.5 Walls and glazing

J1.6 Floors

Part J2 * * * * *

Part J3 Building sealing

Deemed-to-Satisfy Provisions

J3.0 Deemed-to-Satisfy Provisions

J3.1 Application of Part

J3.2 Chimneys and flues

J3.3 Roof lights

J3.4 Windows and doors

J3.5 Exhaust fans

J3.6 Construction of roofs, walls and floors

J3.7 Evaporative coolers

Part J4 * * * * *

Part J5 Air-conditioning and ventilation systems**Deemed-to-Satisfy Provisions**

- J5.0 Deemed-to-Satisfy Provisions
- J5.1 Application of Part
- J5.2 Air-conditioning system control
- J5.3 Mechanical ventilation system control
- J5.4 Fan systems
- J5.5 Ductwork insulation
- J5.6 Ductwork sealing
- J5.7 Pump systems
- J5.8 Pipework insulation
- J5.9 Space heating
- J5.10 Refrigerant chillers
- J5.11 Unitary air-conditioning equipment
- J5.12 Heat rejection equipment

Part J6 Artificial lighting and power**Deemed-to-Satisfy Provisions**

- J6.0 Deemed-to-Satisfy Provisions
- J6.1 Application of Part
- J6.2 Artificial lighting
- J6.3 Interior artificial lighting and power control
- J6.4 Interior decorative and display lighting
- J6.5 Exterior artificial lighting
- J6.6 Boiling water and chilled water storage units
- J6.7 Lifts
- J6.8 Escalators and moving walkways

Part J7 Heated water supply and swimming pool and spa pool plant**Deemed-to-Satisfy Provisions**

- J7.0 Deemed-to-Satisfy Provisions
- J7.1 * * * * *
- J7.2 Heated Water Supply
- J7.3 Swimming pool heating and pumping
- J7.4 Spa pool heating and pumping

Part J8 Facilities for energy monitoring**Deemed-to-Satisfy Provisions**

- J8.0 Deemed-to-Satisfy Provisions
- J8.1 Application of Part
- J8.2 * * * * *
- J8.3 Facilities for energy monitoring

Specification J1.2 Material properties**Deemed-to-Satisfy Provisions**

- 1 Scope
- 2 Construction Deemed-to-Satisfy

Specification J1.5a Calculation of U-Value and solar admittance**Deemed-to-Satisfy Provisions**

- 1 Scope

Specification J1.5b Spandrel panel thermal performance**Deemed-to-Satisfy Provisions**

- 1 Scope
- 2 Spandrel panel R-Value – Calculation Method 1
- 3 Spandrel panel R-Value – Calculation Method 2

Specification J1.6 Sub-floor thermal performance

Deemed-to-Satisfy Provisions

- 1 Scope
- 2 Sub-floor thermal performance

Specification J6 Lighting and power control devices

Deemed-to-Satisfy Provisions

- 1 Scope
- 2 Lighting timer
- 3 Time switch
- 4 Motion detectors

Section J Energy efficiency

Objective

JO1

The Objective of this Section is to reduce greenhouse gas emissions.

Basis of Objective

This Objective reflects the Council Of Australian Governments (COAG) decision in 2009 that a building is to be capable of reducing its greenhouse gas emissions.

National Commitment

In November 1998, all jurisdictions demonstrated their commitment to an effective national greenhouse response by endorsing the National Greenhouse Strategy, a part of which recognised the importance of energy efficiency standards for housing and commercial buildings. An option outlined in the National Greenhouse Strategy was to introduce measures in the BCA to reduce greenhouse gas emissions by efficiently using energy.

On 19 July 2000, the Commonwealth Government announced that agreement had been reached between it and the State and Territory Governments to examine and develop suitable national energy efficiency provisions for domestic and commercial buildings. After taking account of the views of industry, the Commonwealth Government also announced its intention to pursue a strategy that included two elements: firstly, the encouragement of voluntary measures by industry, and secondly, the introduction of minimum mandatory requirements in the BCA.

As a result of the Commonwealth Government's initiative, the Australian Greenhouse Office (AGO) and the Australian Building Codes Board (ABCB) entered into an agreement on 5 January 2001 to develop energy efficiency measures for inclusion in the BCA. Industry was supportive of the need to eliminate worst practice and accepted a minimum mandatory approach because it provides a level playing field. Further, industry took the view that any building-related regulations should be consolidated in the BCA wherever possible.

In 2003, energy efficiency provisions were introduced into the BCA for housing. In 2005, energy efficiency provisions were introduced for other residential buildings. In 2006, the provisions were expanded to include all other building classifications, as well as enhancing the stringency for houses to a target of 5 stars. In 2010, all measures were further strengthened for both commercial and residential buildings as part of the National Strategy on Energy Efficiency. For houses and apartments the stringency was increased to the equivalent of 6 stars.

In 2016, the COAG Energy Council requested a review of the provisions as part of the National Energy Productivity Plan. For commercial buildings this was to involve an economically feasible stringency increase in NCC 2019. For residential buildings this was to involve strengthening the intent and interpretation of the current provisions in preparation for future stringency increase, possibly in NCC 2022.

Goal

The underlying goal of the energy efficiency provisions is to reduce greenhouse gas emissions. Initially this was achieved by efficiently using energy. In BCA 2010, this was broadened to include consideration of the greenhouse intensity of the energy used for the building's services.

It should also be noted that the goal is not focused on occupant comfort. The measures are based on achieving an internal environment in which the conditions are sufficiently tolerable for occupants to minimise their use of services including artificial heating, cooling or lighting.

The energy used over the life of a building has an operational energy component and an embodied energy component. Operational energy, and the related greenhouse gas emissions, is the focus of the NCC at this time; broader environmental sustainability measures may be considered in the future.

Functional Statements

JF1

To reduce greenhouse gas emissions, to the degree necessary—

- (a) a building, including its services, is to be capable of efficiently using energy; and
- (b) a building's services are to obtain their energy from—
 - (i) a low greenhouse gas intensity source; or

Energy efficiency

- (ii) an on-site renewable energy source; or
- (iii) another process, such as reclaimed energy.

JF1 refines the intention of JO1.

The Functional Statement has two parts. The first outlines that a building is to be capable of efficiently using energy. The word “capable” is important, as energy consumption in a building is highly dependent on how the building is used. Energy efficiency cannot be assured simply by ‘building-in’ appropriate measures, as the building also needs to be operated, managed and maintained in an appropriate way.

The second part addresses the need for a low greenhouse gas intensity source or a renewable source of energy for the building’s services.

The greenhouse gas intensity of energy sources vary. For example, natural gas has a low greenhouse gas intensity compared with electricity generated from coal.

For the purposes of [Section J](#), the renewable energy source must be generated and used on-site (so cannot be GreenPower or include energy that is exported to the grid) and includes solar, geothermal, wind and bio-fuels.

Heat reclaimed from another source includes the heat recovered for water heating and water chilling from co-generation type processes as well as other industrial processes.

Importantly, the lead-in words “to the degree necessary” qualify that the use of such energy sources may not always be appropriate or required.

Performance Requirements

JP1

Efficient use of energy

JP1 refines the intention of JO1. A building, and its services, is required to use energy efficiently so that the greenhouse gas emissions associated with its operation are minimised. This is subject to the intended use of the building and the necessary level of occupant comfort. For buildings that are air-conditioned, the amount of energy has also been quantified.

Regulated energy consumption

The term “regulated energy consumption” has been defined to clarify the portion of a building’s energy use that is required to be less than the quantified value. This includes the energy used for air-conditioning, heated water, artificial lighting and lifts, minus the amount of renewable energy generated and used on site.

JP2 * * * * *

The content of JP2, which existed in BCA 2014, has been removed.

JP3 * * * * *

The content of JP3, which existed in NCC 2016, has been removed.

Verification Methods

JV1 NABERS Energy for Offices

This Verification Method allows the use of the modelling protocols and schedules of the National Australian Built Environment Rating System for energy efficiency (known as NABERS Energy) to demonstrate compliance with JP1 for Class 5 buildings. NABERS Energy has a well-established energy modelling framework, which is used primarily to benchmark a building’s energy use against a 6-star scale based on its actual energy consumption over a 12-month period. However under JV1 compliance is shown when an energy model of the building design predicts the energy consumption to be less than 67% of 5.5 stars on the NABERS Energy for Offices base-building scale. 67% of 5.5 stars is roughly equivalent to a 6-star NABERS Energy rating.

Commitment Agreement

In addition to the energy model, the Verification Method requires a NABERS Energy for Offices base-building Commitment Agreement to be obtained. This ensures that the necessary rating has been verified through the NABERS Energy process, committing to the design being followed through to the building’s operation.

The different targets set for the Commitment Agreement and energy modelling recognises that it is common industry practice to commit to a lower NABERS Energy rating than is likely to be achieved. This is to allow for factors outside the control of the designer relating to the building’s operation, which can impact on its ability to achieve a higher rating.

Thermal comfort

To ensure that occupant comfort is not compromised in the pursuit of energy efficiency, an assessment of the Predicted Mean Vote (PMV) is also a requirement of the Verification Method. PMV predicts the occupant comfort of a given design. The calculation of PMV uses much of the same information that is used in the creation of energy models.

Use of Adaptive Thermal Comfort as a Performance Solution

The PMV metric is designed for fully mechanically ventilated buildings. In situations where a building uses mix-mode or naturally ventilating air-conditioning systems, the Adaptive Thermal Comfort metric may be more appropriate. This can be used as a Performance Solution subject to the approval of the building regulatory authority. Adaptive Thermal Comfort can also be used in combination with PMV in buildings that have both fully mechanical and partially naturally ventilated spaces.

To demonstrate compliance, it is suggested that the equivalent result produced by an Adaptive Thermal Comfort Model should be not less than 80% acceptability achieved across not less than 95% of the floor area of all occupied zones not less than 98% of the hours of operation of the building. Note, this is likely to be appropriate for buildings that meet the applicability criterion in Section 5.4.1 of ASHRAE 55-2013.

JV2 Green Star

This Verification Method allows the use of the Green Star rating tool to demonstrate compliance with [JP1](#) for Class 3, 5, 6, 7, 8 and 9 buildings, or common areas of a Class 2 building. Green Star rates buildings across a range of sustainability categories, including energy efficiency. As with [JV3](#) (below), the energy efficiency category of Green Star is based on comparing the proposed building to a reference building compliant with the Deemed-to-Satisfy Provisions in Section J. The schedules and assumptions in the Green Star protocols are different to those of [JV3](#), but are considered equivalent for the purpose of compliance with [JP1](#). Note, in fulfilling all of the sustainability categories for a Green Star rating a building exceeds the energy efficiency requirements of [JP1](#).

Registration

The project is required to be registered for a Green Star – Design & As-Built rating to confirm its compliance with the Green Star modelling requirements.

Thermal comfort

To ensure that occupant comfort is not compromised in the pursuit of energy efficiency, an assessment of the Predicted Mean Vote (PMV) is also a requirement of the Verification Method. PMV predicts the occupant comfort of a given design. Its calculation is based on factors that are used to predict energy consumption.

JV3 Verification using a reference building

This Verification Method compares the greenhouse gas emissions of a proposed building to that of a reference building which is based on the Deemed-to-Satisfy Provisions. If the greenhouse gas emissions of the proposed building do not exceed that of the reference building, compliance with [JP1](#) is achieved.

Through this modelling process, it must be demonstrated that the Performance Solution is equivalent to, or better than, the Deemed-to-Satisfy Provisions. This equivalency is also one of the Assessment Methods recognised in the NCC.

[JV3](#) includes provisions in [JV3\(a\)\(i\)\(B\)](#) which are designed to protect the thermal performance of the building's envelope from "trading" off its performance with that of the building services.

The steps to using this Verification Method are:

1. Determine the annual greenhouse gas emissions allowance by modelling a reference building, i.e. a Deemed-to-Satisfy complying building based on the criteria in [Clauses 2, 3 and 4](#) of [Specification JVb](#).
2. Calculate the theoretical annual greenhouse gas emissions of the proposed Performance Solution using the criteria in [Clauses 3 and 4](#) of [Specification JVb](#).
3. Calculate the theoretical annual greenhouse gas emissions of the proposed Performance Solution, with the services modelled as if they were the same as that of the reference building. This tests the performance of the facade.
4. Compare the theoretical annual greenhouse gas emissions calculated in steps 2 and 3 to the annual greenhouse gas emissions allowance calculated in step 1 to ensure that in both cases, the annual greenhouse gas emissions are not more than that allowed.

The same software must be used in all modelling runs.

[JV3](#) can be used for all buildings using the occupancy profiles and other assumptions provided in [Specifications JVb](#) and [JVC](#).

The following flowchart illustrates how [JV3](#) can be used to assess different Performance Solutions.

Energy efficiency

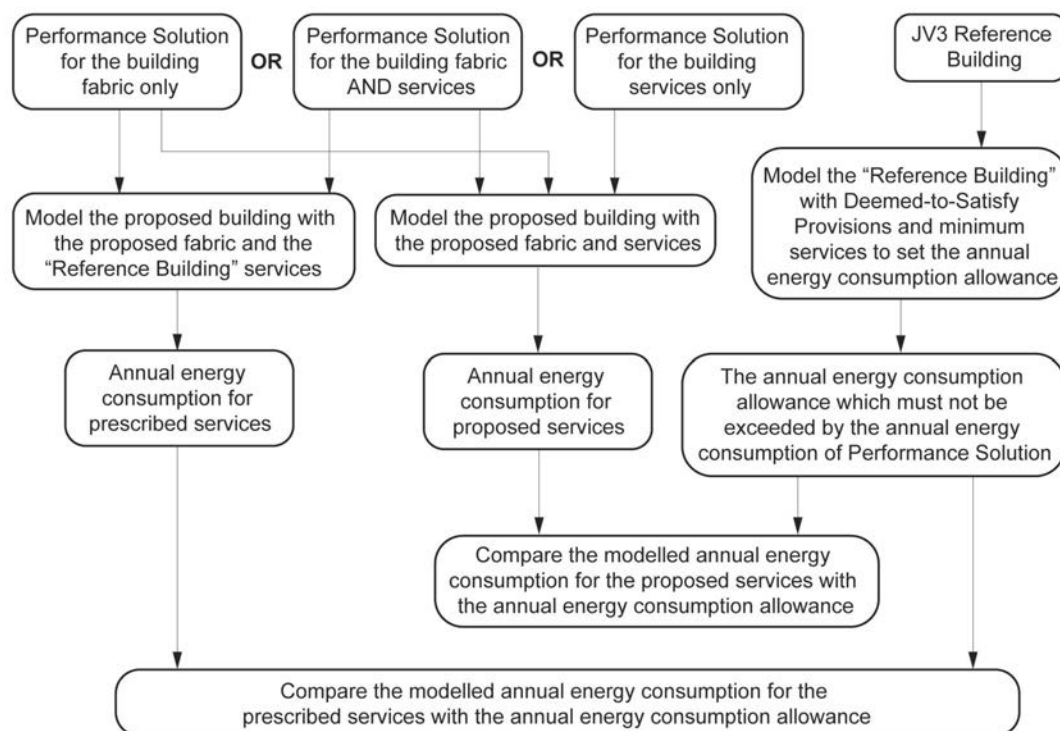

JV4 Building envelope sealing

Building sealing is essential for facilitating the energy efficiency of a building. [JV4](#) provides a method of demonstrating compliance with the building sealing requirements in [JP1\(e\)](#). This provides an alternative compliance option to the prescriptive building sealing requirements in [Part J3](#).

[JV4](#) quantifies the level of sealing (expressed as an air permeability rate) appropriate for different building classifications and climate zones. The method for testing the sealing level is through a blower door test carried out in accordance with Method 1 of AS/NZS ISO 9972.

Envelope sealing has less impact on buildings that do not operate overnight and which are located within relatively mild climates (i.e. climate zones 2 and 5). Envelope sealing can have a reduced benefit in these circumstances as these buildings are less likely to cool naturally overnight and may require additional cooling energy than necessary the next day. However, if buildings in these climate zones are operated in a manner that expels warm air and draws in cool air overnight as part of its cooling regime (typically known as night purging), then a lower air permeability rate could be beneficial.

Specification JVa**Additional requirements****1. Scope****Intent**

To clarify that there are additional requirements to the modelling under [JV1](#), [JV2](#) or [JV3](#) that must be carried out.

2. Additional requirements – General**Intent**

To prescribe those Deemed-to-Satisfy Provisions and referenced documents that need to be complied with in addition to the modelling requirements of [JV1](#), [JV2](#) and [JV3](#).

This clause lists requirements from the Deemed-to-Satisfy Provisions and referenced documents which must be complied with in addition to the necessary modelling. This is to overcome limitations in the modelling process by ensuring buildings designed under [JV1](#), [JV2](#) and [JV3](#) cover the same range of energy efficiency attributes as the Deemed-to-Satisfy Provisions. For example, the standard of installing insulation is covered in [Subclause 2\(a\)](#) of [Specification JVa](#) because it is not specifically addressed through modelling alone.

3. Additional requirements – NABERS Energy for Offices**Intent**

To prescribe those Deemed-to-Satisfy Provisions that need to be complied with in addition to the modelling requirements of [JV1](#).

4. Additional requirements – Green Star**Intent**

To prescribe those Deemed-to-Satisfy Provisions that need to be complied with in addition to the modelling requirements of [JV2](#).

Specification JVb**Modelling parameters****1. Scope****Intent**

To prescribe how the modelling of the proposed and reference building is to be carried out under [JV2](#) and [JV3](#). This Specification details the methodology for modelling Performance Solutions under [JV2](#) and [JV3](#). In particular, it details the inputs required for the proposed and reference building.

2. Reference building**Intent**

To prescribe how the modelling of the reference building is to be carried out.

3. Proposed building and reference building**Intent**

To prescribe how the modelling of both the proposed and reference building is to be carried out. [Subclause 3\(c\)\(vii\)\(D\)](#) of [Specification JVb](#) permits the profiles and internal heat loads of the proposed building to be used in the calculations provided the operating hours are not less than 2,500 per year. The profiles and loads of [Specification JVc](#), NABERS Energy or Green Star need only be used if the hours of operation are less than 2,500 per year. The reason for permitting the expected profiles and internal loads of the proposed building to be used is that, provided the numbers of hours of operation are reasonable, different hours and loads have minimal impact on the modelled outcome as the same values must be used in assessing the reference building as well as the proposed building.

4. Services – proposed and reference building**Intent**

To prescribe the detailed modelling requirements for the services of both the proposed and reference building.

Specification JVc

Modelling profiles

1. Scope

Intent

To prescribe the operation profiles that may be used in the modelling required by [JV2](#) and [JV3](#).

2. Modelling profiles

Intent

To prescribe the operation profiles for air-conditioning, artificial lighting, and equipment and appliances that may be used to model the proposed and reference building.

This Specification sets out standard operation profiles for calculating the annual energy consumption, and hence annual greenhouse gas emissions, of a proposed and reference building. It provides various options in [Table 2n](#) to account for heat gains per person and where applicable, heat gains from meals. The number of people must be calculated in accordance with [D1.13](#).

Although the values stated may not be those actually achieved in some buildings, the values are derived from industry accepted data sources and are considered the most typical. The same rates apply for the proposed building and reference building under [JV2](#) and [JV3](#).

They do not have to be used as part of the Verification Methods provided the operating hours of the building per year used in the calculation are not less than 2,500 hours. The profiles in the NABERS Energy and Green Star simulation requirements can also be used (see [subclause 3\(c\)\(vii\)](#) of [Specification JVb](#)).

Part J0 Energy efficiency

Deemed-to-Satisfy Provisions

J0.0 Deemed-to-Satisfy Provisions

Intent

To clarify that [JP1](#) will be satisfied if compliance is achieved with [Parts J1 to J8](#).

Where a solution is proposed to comply with the Deemed-to-Satisfy Provisions, [J0.0](#) clarifies that compliance with [Parts J1 to J8](#) achieves compliance with [JP1](#).

Where a Performance Solution is proposed, the relevant Performance Requirements must be determined in accordance with [A2.2\(3\)](#) and [A2.4\(3\)](#) as applicable. (See commentary on [Part A2](#)).

The Deemed-to-Satisfy Provisions described are limited to the most common forms of construction and the simplest forms of buildings. It is expected that the more innovative construction techniques and the more complex buildings will be designed and assessed using a performance approach.

The measures have been developed using a cost-effectiveness model.

A major consideration in developing the measures was the likelihood of a building being heated or cooled by an air-conditioning system, and whether the Deemed-to-Satisfy Provisions should assume this to be the case, or only apply the provisions if a heating or cooling system is installed. It is recognised that most Class 3, 5, 6 and 9 buildings and some Class 7 and 8 buildings are heated or cooled, and this is the basis of the provisions. Consideration was also given to the fact that although the first owner may be prepared to 'manage' their building in the appropriate manner, the next owner or tenant may not, and instead may install air-conditioning.

Because of the performance-based structure of the NCC, a Performance Solution may be proposed instead of the Deemed-to-Satisfy Provisions.

J0.1 Application of Section J

Intent

To clarify which provisions of Section J apply to dwellings and which provisions apply to other buildings.

[J0.1](#) explains which provisions need to be complied with for—

- a sole-occupancy unit of a Class 2 building or a Class 4 part; and
- all other classifications.

[J0.1\(a\)](#) explains that, for the thermal performance of the building fabric, there are two paths for compliance depending on whether the building contains dwellings (i.e. sole-occupancy units in a Class 2 building or a Class 4 part) or not. For the fabric of dwellings, compliance must be in accordance with [J0.2](#) while for other building classifications, compliance must be in accordance with [Parts J1](#) and [J3](#). For services, all buildings must comply with [Parts J5 to J8](#).

All buildings must comply with [J0.1\(b\) to \(e\)](#), including sole-occupancy units of a Class 2 building or Class 4 part, due to these matters not being assessed by house energy rating software.

The means of compliance is explained in [Figure J0.1](#).

Figure J0.1 Flow chart of compliance with Section J0

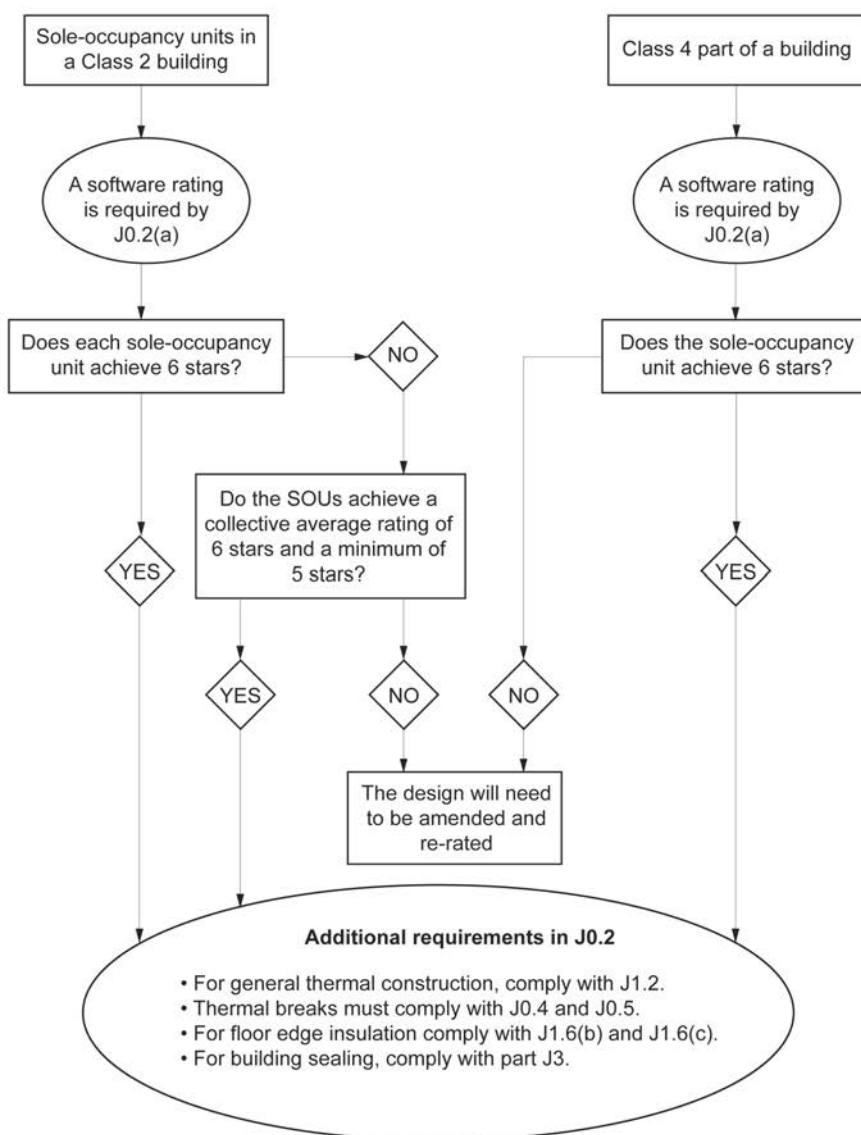

J0.2 Reducing the heating and cooling loads of a sole-occupancy unit of a Class 2 building or a Class 4 part

Intent

To clarify how the shell of a sole-occupancy unit of a Class 2 building or a Class 4 part are to comply.

In order to reduce the heating or cooling loads, the fabric of a sole-occupancy unit of a Class 2 building or a Class 4 part must achieve the required house energy rating and the separate heating and cooling load limits. Information about building modelling using house energy rating software is available at www.nathers.gov.au. The applicable heating and cooling load limits are published in the ABCB Standard for NatHERS Heating and Cooling Load Limits, which can be accessed at www.abcb.gov.au.

It must also comply with a few general Deemed-to-Satisfy Provisions relating to the insulation standard, installation of insulation, thermal breaks, sealing, etc.

The measures for a sole-occupancy unit of a Class 2 building or a Class 4 part of a building are similar to those adopted for Class 1 buildings in BCA Volume Two - Housing Provisions. There are several reasons for this, including:

- Many Class 2 and 4 buildings are very similar in thermal performance to Class 1 buildings.
- Being dwellings, there are similarities in their use with high occupancy at night.

Energy efficiency

- Having all types of dwellings achieving comparable performance provides a consistent approach.

Importantly, as per Class 1 buildings, a sole-occupancy unit of a Class 2 building and a Class 4 part of a building must satisfy both the required star rating and the corresponding heating and cooling load limits. The star rating is based on the combined heating and cooling load of the dwelling, whereas compliance with the heating and cooling load limits is dependent on the separate heating and cooling loads of the dwelling.

Further information about house energy rating and heating and cooling load limits can be obtained on the website of the Nationwide House Energy Rating Scheme.

J0.3 Ceiling fans**Intent**

To set the minimum requirements for ceiling fans.

A ceiling fan may be required to provide high air movement as part of a house energy rating software solution and two sizes of fans are described in terms of their diameter and the floor area they serve.

Part J1 Building fabric

Deemed-to-Satisfy Provisions

J1.0 Deemed-to-Satisfy Provisions

Intent

To clarify that [JP1](#) will be satisfied if compliance is achieved with [Parts J1 to J8](#).

See comments for Deemed-to-Satisfy Provisions of [J0.0](#).

J1.1 Application of Part

Intent

To facilitate the efficient use of energy appropriate for Class 2 to 9 buildings that are conditioned or likely to be conditioned.

The Deemed-to-Satisfy Provisions of [Part J1](#) apply to building elements that form part of the envelope, where the envelope separates a conditioned space or habitable room from the exterior of the building or a non-conditioned space. This includes roofs, walls, glazing and floors as per the definition of “fabric”.

Some Class 6, 7, 8 and 9b buildings that are not a conditioned space by definition may be excluded from controls for building fabric. Class 6 and 9b buildings cover a wide range of uses and some could reasonably be expected to be air-conditioned at some time in the future while others may not. For example, it may be unlikely that a school gymnasium will be air-conditioned while classrooms may well be when funds are available. Some States are already retrofitting air-conditioning to schools. Note that the phrase “likely by the intended use of the space to be air-conditioned” is in the definition of a conditioned space.

The external elements of an atrium or solarium that is not a conditioned space may also be excluded. The atrium may be attached to a Class 5 building and would otherwise attract some of the requirements appropriate for a Class 5 building. Again, either there is no energy saving to be made by thermally treating the elements, or the saving is below the minimum threshold and so not cost-effective.

The Deemed-to-Satisfy Provisions of [Part J1](#) do not apply to Class 8 electricity network substations as these buildings are not required to be air-conditioned for the purposes of [Section J](#). See the definition for air-conditioning. The air-conditioning systems of these buildings are instead designed to maintain the efficient operation of sensitive electrical equipment.

J1.2 Thermal construction — general

To outline the general requirements to insulate a building’s fabric and the inherent thermal properties of roof, ceiling, wall and floor materials.

Testing

[J1.2\(a\)](#) requires that insulation must be tested and labelled in accordance with AS/NZS 4859.1.

Installation

Care should be taken when installing insulation to ensure a continuous envelope between a conditioned space and either the outside environment or a non-conditioned space.

Insulation is to be fitted tightly to each side of framing members but need not be continuous over the framing member. The insulation requirements in [J1.3](#), [J1.5](#) and [J1.6](#) are calculated for parts of the roof, walls or floor that are clear of any framing members. The means of achieving the required total R-Value must be in accordance with [J1.2\(e\)](#).

The provisions also state that the installation of insulation should not interfere with the safety or performance of domestic services and fittings such as heating flues, recessed light fittings, transformers for low voltage lighting, gas appliances and general plumbing and electrical components. This includes providing appropriate clearance as detailed in relevant legislation and referenced standards such as for electrical, gas and fuel oil installations. Low voltage lighting transformers should not be covered by insulation and be mounted above the insulation rather than on the ceiling. Expert advice may also be needed on how much bulk insulation can be placed over electrical wiring.

Note that the addition of insulation to other building elements may alter the fire properties of those elements. Re-testing

or re-appraisal of these elements may be required.

Airspace adjoining reflective insulation

For reflective insulation to achieve its tested R-Value, the airspace adjoining the insulation needs to be a certain width. This width varies depending on the particular type of reflective insulation and the R-Value to be achieved.

Where the width of airspace is to be achieved in a wall cavity or the like, care should be taken to ensure compliance with all other applicable BCA provisions. For example, the provisions relating to weatherproofing masonry may require a greater width of cavity.

Compression of bulk insulation

The R-Value of bulk insulation is reduced if it is compressed. The allocated space for bulk insulation is therefore to allow the insulation to be installed so that it maintains its correct thickness unless exempted such as at wall studs. This is particularly relevant to wall and cathedral ceiling framing whose members can only accommodate a limited thickness of insulation. In some instances, larger framing members or thinner insulation material, may be necessary to ensure that the insulation achieves its required R-Value.

Artificial cooling

Artificial cooling of buildings in some climates can cause condensation to form inside the layers of the building envelope. Such condensation can cause significant structural or cosmetic damage to the envelope before it is detected. Associated mould growth may also create health risks to the occupants. Effective control of condensation is a complex issue. In some locations a fully sealed vapour barrier may need to be installed on the more humid, or generally warmer, side of the insulation.

Thermal bridging

A thermal bridge, also called a cold bridge or heat bridge, is an area or component of the fabric which has higher thermal conductivity than the surrounding materials, creating a path of least resistance for heat transfer. Thermal bridges can significantly reduce the thermal performance of a facade, increasing energy use from a building's heating and cooling systems. If not accounted for, they can also cause unwanted condensation and comfort issues in a building. In line with the existing requirements of AS/NZS 4859.1, [J1.2\(e\)](#) specifies that the means of achieving the required Total R-Value must be determined in accordance with AS/NZS 4859.2. This Standard comprises a calculation method that takes into account the impact of thermal bridges on the thermal performances of a facade. Depending on the extent of the thermal bridges within a facade, extra insulation may need to be added, or thermal breaks installed in order for a facade to be compliant.

J1.3 Roof and ceiling construction

Intent

To clarify the minimum Total R-Value that is to be achieved by a roof or ceiling, according to the building classification and climate zone in which it is located.

[J1.3](#) covers roofs, including their ceilings, and any ceiling that is part of an intermediate floor being part of the building's envelope, or where there is no ceiling.

[J1.3\(a\)](#) details the insulation properties and minimum Total R-Value required of a roof or ceiling.

Part or all of this may be provided by the roof construction itself and any inherent insulating property of the roof and airspaces reduces the amount of insulation needed.

Where the ceiling space below the roof is used as the return air plenum, it is considered part of the conditioned space. In this instance, the envelope boundary for the roof and ceiling construction is located at the roof.

The direction of heat flow stated should not be taken as the only direction in which any insulating properties operate but it is a statement of the prominent direction for that particular climate zone. It is assumed that materials, be they construction materials or insulating materials, will also have insulating properties in the other direction. For a residential building, the night time direction is important as the building is most likely to be occupied at that time and the outside temperature likely to be the lowest of the day.

The Total R-Value in [J1.3\(a\)](#) is dependent on the climate zone.

As with walls, the effect of thermal bridging must be taken into account when determining if the minimum R-Value of a roof has been achieved. In some cases, thermal breaks will be necessary to achieve compliance.

A thermal break may be provided by materials such as timber or expanded polystyrene strips, plywood or bulk insulation. Reflective insulation alone is not suitable for use as a thermal break because it requires an adjoining airspace to achieve the specified R-Value.

The weight of roof or ceiling insulation needs to be considered in the selection of plasterboard, plasterboard fixings and building framing.

There may be instances where there is a loss of ceiling insulation because of downlights, fans and other penetrations. In

Energy efficiency

these circumstances it is the responsibility of designers to determine how they will achieve the required Total R-Value given the construction of the roof and the penetrations.

Details of the Total R-Values of typical constructions are provided in this Guide.

Typical construction

The Total R-Value of the basic roof and ceiling has been determined by adding together the material R-Values of the outdoor air film, roof cladding, roof airspace, ceiling sheet lining and internal air film.

The Total R-Value of the roof and ceiling materials may need to be adjusted if other building elements, such as sarking, are to also be installed.

Note that it should not be assumed that these figures are representative of all construction scenarios. For example the spacing of framing members, the presence of roof lights or the specific type of frame could all affect the actual Total R-Value by creating thermal bridging between elements or by compressing insulation. If following a Deemed-to-Satisfy compliance pathway, the code requires in [J1.2\(e\)](#) that AS/NZ 4859.2 be used to calculate the Total R-Value of a building's envelope.

Insulation can be installed in the roof, the ceiling, or a combination of both, provided the required thermal performance is achieved and other aspects of the building's integrity are not compromised. It should be noted that the thermal performance of the roof may vary depending on the position of the insulation, the climatic conditions, the design of the building and the way in which it is operated. For example, although not recognised in the values, insulation installed under the roof, rather than on the ceiling, in a building with a large roof space in a cold climate, or when a room is being air-conditioned, may be less effective because of the additional volume of roof airspace that would need to be heated or cooled.

For a material that is not listed as an item in the figure below, other than air, the R-Value may be determined by dividing the thickness of the item in metres by the thermal conductivity in W/m.K (typical values are described in [Specification J1.2](#)).

There are a number of different insulation products that may be used to achieve the minimum added R-Value. Care should be taken to ensure that the choice made is appropriate for the construction and climate conditions. For instance, in some climate zones, an impermeable insulation sheet needs to be installed with due consideration of condensation and associated interaction with adjoining building materials.

Roof construction description	Item	Item description	R-Value unventilated		R-Value ventilated	
			Up	Down	Up	Down
(a) Roof 15° to 45° pitch <ul style="list-style-type: none"> • Horizontal ceiling • Metal cladding 	1.	Outdoor air film (7 m/s)	0.04	0.04	0.04	0.04
	2.	Metal cladding	0.00	0.00	0.00	0.00
	3.	Roof airspace (non-reflective)	0.18	0.28	0.00	0.46
	4.	Plasterboard gypsum (10 mm, 880 kg/m ³)	0.06	0.06	0.06	0.06
	5.	Indoor air film (still air)	0.11	0.16	0.11	0.16
	Total R-Value			0.39	0.54	0.21

Energy efficiency

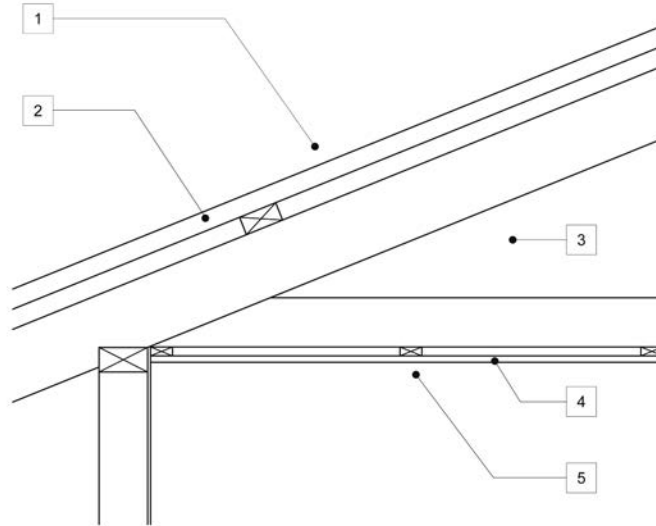

Roof construction description	Item	Item description	R-Value unventilated		R-Value ventilated	
			Up	Down	Up	Down
(b) Roof 15° to 45° pitch <ul style="list-style-type: none"> Horizontal ceiling Clay tiles 19 mm 	1.	Outdoor air film (7 m/s)	0.04	0.04	0.04	0.04
	2.	Roof tile, clay or concrete (1922 kg/m ³)	0.02	0.02	0.02	0.02
	3.	Roof airspace (non-reflective)	0.18	0.28	0.00	0.46
	4.	Plasterboard gypsum (10 mm, 880 kg/m ³)	0.06	0.06	0.06	0.06
	5.	Indoor air film (still air)	0.11	0.16	0.11	0.16
	Total R-Value			0.41	0.56	0.23

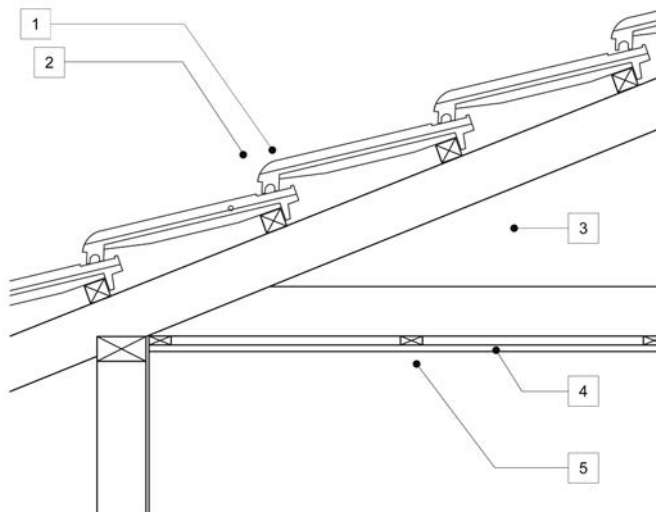

Roof construction description	Item	Item description	R-Value unventilated	
			Up	Down
(c) Cathedral ceiling 15° to 45° pitch <ul style="list-style-type: none"> 10 mm plaster on top of rafters 	1.	Outdoor air film (7 m/s)	0.04	0.04
	2.	Metal cladding	0.00	0.00
	3.	Roof airspace (30 mm to 100 mm, non-reflective)	0.15	0.18

Energy efficiency

Roof construction description	Item	Item description	R-Value unventilated	
			Up	Down
<ul style="list-style-type: none"> Metal external cladding 				
	4.	Plasterboard gypsum (10 mm, 880 kg/m ³)	0.06	0.06
	5.	Indoor air film (still air)	0.11	0.16
	Total R-Value		0.36	0.42

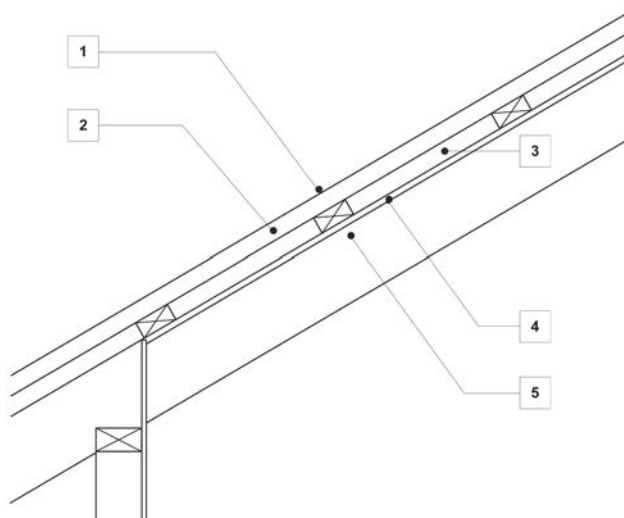

Roof construction description	Item	Item description	R-Value unventilated	
			Up	Down
(d) Cathedral ceiling 15° to 45° pitch <ul style="list-style-type: none"> 10 mm plaster on top of rafters Tiles external cladding 	1.	Outdoor air film (7 m/s)	0.04	0.04
	2.	Roof tile, clay or concrete (1922 kg/m ³)	0.02	0.02
	3.	Roof airspace (30 mm to 100 mm, non-reflective)	0.15	0.18
	4.	Plasterboard gypsum (10 mm, 880 kg/m ³)	0.06	0.06
	5.	Indoor air film (still air)	0.11	0.16
	Total R-Value		0.38	0.44

Energy efficiency

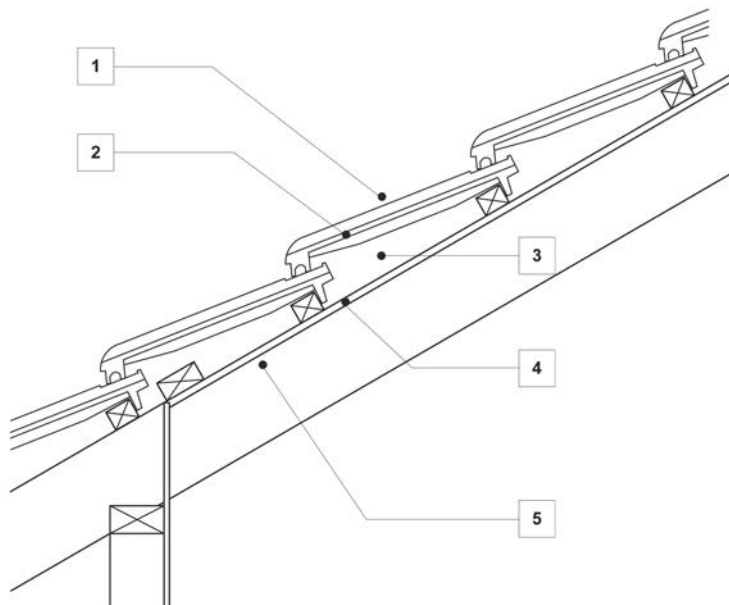

Roof construction description	Item	Item description	R-Value unventilated	
			Up	Down
(e) Skillion roof less than 5° pitch <ul style="list-style-type: none"> 10 mm plaster below rafters Metal external cladding 	1.	Outdoor air film (7 m/s)	0.04	0.04
	2.	Metal cladding	0.00	0.00
	3.	Roof airspace (100 mm to 300 mm, non-reflective)	0.15	0.22
	4.	Plasterboard gypsum (10 mm, 880 kg/m ³)	0.06	0.06
	5.	Indoor air film (still air)	0.11	0.16
	Total R-Value			0.36

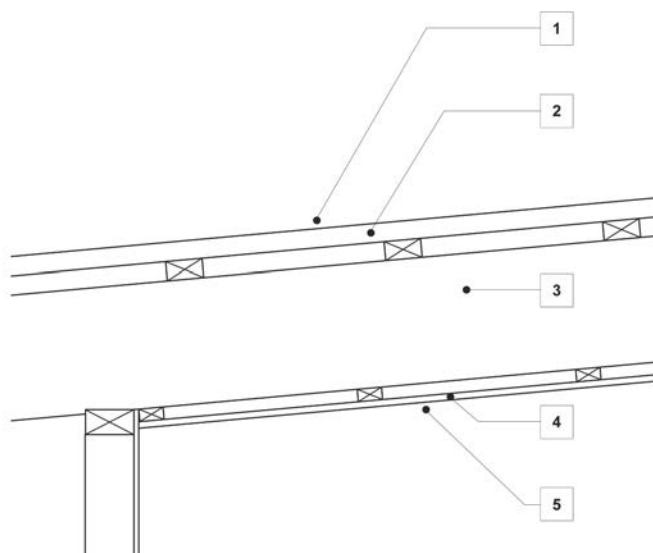

Roof construction description	Item	Item description	R-Value unventilated	
			Up	Down
(f) Skillion roof 5° to 15° pitch <ul style="list-style-type: none"> 10 mm plaster on top of rafters Metal external 	1.	Outdoor air film (7 m/s)	0.04	0.04
	2.	Metal cladding	0.00	0.00
	3.	Roof airspace (30 mm to 100 mm, non-reflective)	0.15	0.21

Energy efficiency

Roof construction description	Item	Item description	R-Value unventilated	
			Up	Down
cladding				
	4.	Plasterboard gypsum (10 mm, 880 kg/m ³)	0.06	0.06
	5.	Indoor air film (still air)	0.11	0.16
	Total R-Value		0.36	0.47

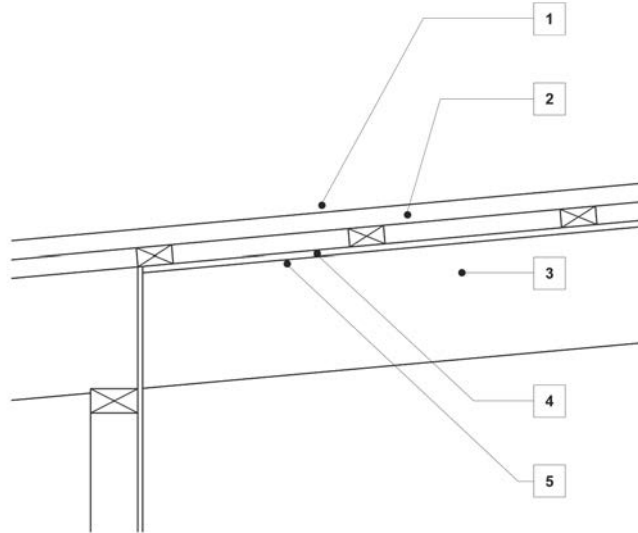

Roof construction description	Item	Item description	R-Value unventilated	
			Up	Down
(g) 100 mm solid concrete roof to 5° <ul style="list-style-type: none"> 10 mm plaster, suspended ceiling Applied external waterproof membrane 	1.	Outdoor air film (7 m/s)	0.04	0.04
	2.	Waterproof membrane, rubber synthetic (4 mm, 961 kg/m ³)	0.03	0.03
	3.	Solid concrete (100 mm, 2400 kg/m ³)	0.07	0.07
	4.	Ceiling airspace (100 mm to 300 mm, non-reflective)	0.15	0.22
	5.	Plasterboard, gypsum (10 mm, 880 kg/m ³)	0.06	0.06
	6.	Indoor air film (still air)	0.11	0.16
	Total R-Value		0.46	0.58

Energy efficiency

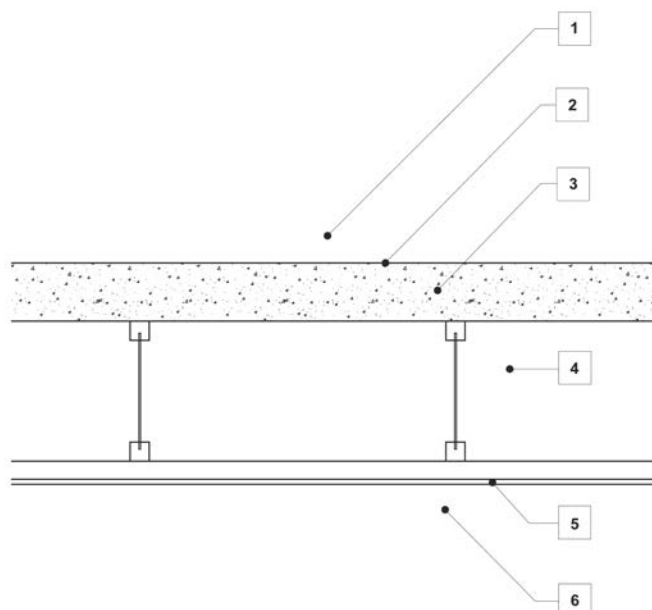
**Notes:**

1. The R-Value of an item, other than an airspace, air film or air cavity, may be increased in proportion to the increased thickness of the item.
2. The Total R-Value of a form of construction may be increased by the amount that the R-Value of an individual item is increased, except where the item is thermally bridged.
3. Where an airspace is filled, the R-Value listed for the airspace must be deducted from the Total R-Value of the roof construction.
4. For information on a roof space that is considered to be ventilated, see Specification J1.2 [Clause 2\(d\)](#).

J1.4 Roof lights**Intent**

To specify requirements for roof lights and provide a reasonable distribution of the roof lights.

J1.4 has values for Total System SHGC and Total System U-Values, which are expressed in accordance with the Australian Fenestration Rating Council (AFRC) protocol.

The provisions of J1.4(a) require roof lights that form part of the envelope, other than of a sole-occupancy unit of a Class 2 building or a Class 4 part of a building, comply with Table J1.4.

The size of roof lights is limited to no more than 5% of the floor area of the space served in order to ensure that the thermal performance of a roof is not compromised to too great an extent. Larger roof lights will need to achieve compliance through a Verification Method or as a Performance Solution.

Table J1.4 provides the Total System SHGC requirements that satisfy J1.4(a).

J1.5 Walls and glazing**Intent**

To specify the requirements for walls and windows, both external and internal, that are a part of the envelope.

J1.5(a) contains the basic Total System U-Values and Total R-Values that need to be achieved by wall-glazing construction forming the envelope of a building. Importantly, this applies to both external and internal wall-glazing construction that form part of the building envelope. J1.5(e) contains the basic solar admittance values that must not be exceeded by externally-facing wall-glazing construction. Importantly, this subclause only applies to external wall-glazing construction forming part of the building envelope.

There are two calculation methods for determining compliance with the Total System U-Value and solar admittance requirements in J1.5(a) and (e). The first method involves assessing wall-glazing construction facing a single aspect (or direction). The second method involves assessing together the wall-glazing construction facing multiple aspects. These

methods are detailed in [Specification J1.5a](#).

J1.6 Floors

Intent
To outline the minimum insulation requirements for suspended floors and concrete slabs on ground.

For a floor that is part of the building envelope other than a sole-occupancy unit in a Class 2 building or Class 4 part of a building, the required Total R-Values are in [Table J1.6](#). For the purposes of calculating the Total R-Value of a floor, the R-Value attributable to an in-slab or in-screed heating or cooling system is not included.

[J1.6\(b\)](#) and [\(c\)](#) apply to all concrete slab on ground floors including those in sole-occupancy units in a Class 2 building, or Class 4 part of a building as described in [J0.1](#).

[J1.6\(b\)](#) requires all floors with an embedded in-slab or in-screed heating or cooling system to have additional insulation installed around the vertical edge of the perimeter. This provision aims to limit heat loss or gain through the perimeter of the slab.

Regarding the installation of slab edge insulation in [J1.6\(c\)](#), care should be taken to ensure that the insulation is compatible with the type of termite management system selected.

Typical construction

The figure below outlines the thermal performance of some of the more common forms of floor construction. For a material that is not listed in the figure below, other than air, the material R-Value may be determined by dividing the thickness of the item in metres by the thermal conductivity in W/m.K (typical values are described in [Specification J1.2](#)).

For the purposes of calculating the Total R-Value of a floor, the R-Value attributable to an in-slab or in-screed heating or cooling system is not included.

Note that it should not be assumed that these figures are representative of all construction scenarios. For example the spacing of stumps, or the specific type of frame could all affect the actual Total R-Value by creating thermal bridging between elements or by compressing insulation. If following a Deemed-to-Satisfy compliance pathway, Total R-Value must be calculated using the methods prescribed in AS/NZS 4859.2 to properly account for these effects.

Floor construction description	Item	Item description	R-Value	
			Up	Down
(a) Timber internal floor, 10 mm internal plaster	1.	Indoor air film (still air)	0.11	0.16
	2.	Particleboard flooring (19 mm, 640 kg/m ³)	0.15	0.15
	3.	Floor airspace, 100 mm to 300 mm (non-reflective)	0.15	0.22
	4.	Plasterboard, gypsum (10 mm, 880 kg/m ³)	0.06	0.06
	5.	Indoor air film (still air)	0.11	0.16
	Total R-Value			0.58

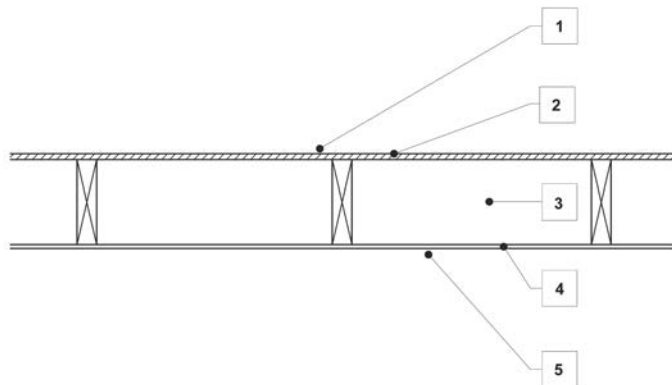

Energy efficiency

Floor construction description	Item	Item description	R-Value	
			Up	Down
(b) Timber, suspended ground floor, open subfloor	1.	Indoor air film (still air)	0.11	0.16
	2.	Particleboard flooring (19 mm, 640 kg/m ³)	0.15	0.15
	3.	Outdoor air film (still air)	0.04	0.04
	Total R-Value		0.30	0.35

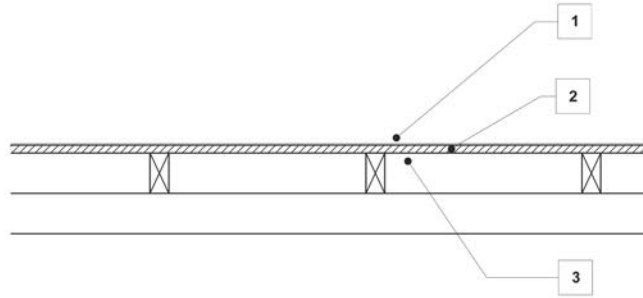

Floor construction description	Item	Item description	R-Value	
			Up	Down
(c) Solid concrete suspended slab	1.	Indoor air film (still air)	0.11	0.16
	2.	Solid concrete (150 mm, 2400 kg/m ³)	0.10	0.10
	3.	Outdoor air film (still air)	0.04	0.04
	Total R-Value		0.25	0.30

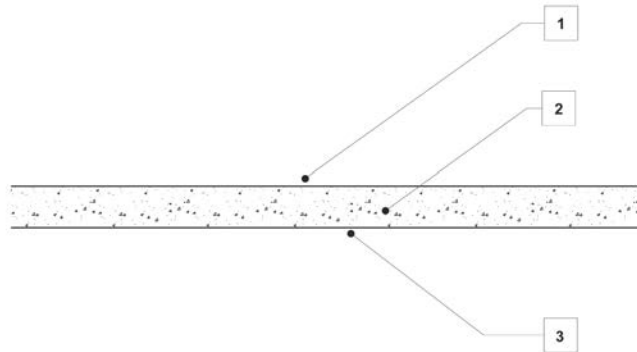

Floor construction description	Item	Item description	R-Value	
			Up	Down
(d) 150 mm hollow-core concrete planks	1.	Indoor air film (still air)	0.11	0.16
	2.	Concrete topping (60 mm, 2,400 kg/m ³)	0.04	0.04
	3.	Hollow-core concrete planks (150 mm, 1,680 kg/m ³ , 30% cores)	0.14	0.14
	4.	Outdoor air film (7 m/s)	0.04	0.04
	Total R-Value		0.33	0.38

Energy efficiency

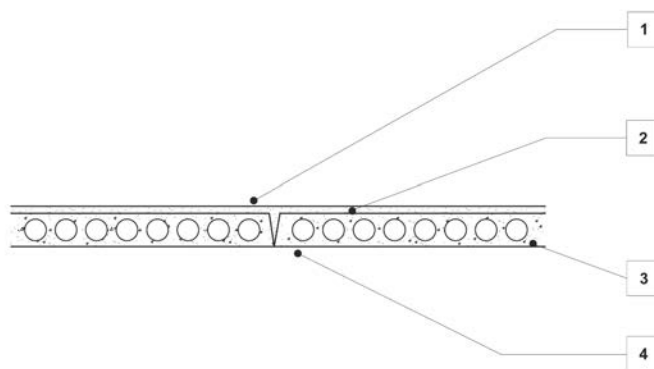

Floor construction description	Item	Item description	R-Value	
			Up	Down
(e) 100 mm solid concrete slab-on-ground	1.	Indoor air film (still air)	0.11	0.16
	2.	Solid concrete (100 mm, 2400 kg/m ³)	0.07	0.07
	3.	Ground thermal resistance	-	-
	Total R-Value		0.18	0.23

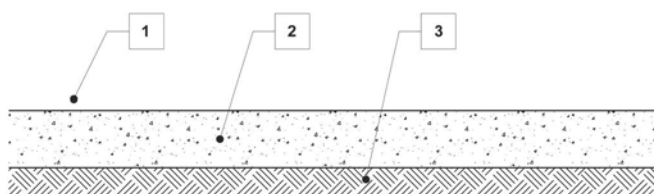

Floor construction description	Item	Item description	R-Value	
			Up	Down
(f) 150 mm solid concrete slab-on-ground	1.	Indoor air film (still air)	0.11	0.16
	2.	Solid concrete (150 mm, 2400 kg/m ³)	0.10	0.10
	3.	Ground thermal resistance	-	-
	Total R-Value		0.21	0.26

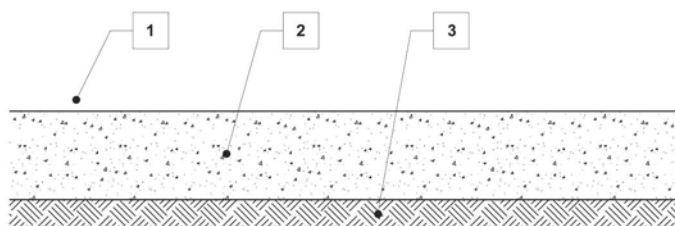

Notes:

1. The R-Value of an item, other than an airspace, air film or air cavity, may be increased in proportion to the increased thickness of the item.
2. The Total R-Value of a form of construction may be increased by the amount that an individual item is increased.
3. For floor types located on soil or over a sub-floor space, the Total R-Value should be calculated in accordance with [Specification J1.6](#) or Section 3.5 of CIBSE Guide A.
4. Where a reflective building membrane is attached beneath the floor with a 100 mm reflective airspace, add R0.38 for heat flow up and R1.14 for heat flow down.
5. The addition of 10 mm of render to the ceiling of a suspended internal concrete floor will increase the Total R-Value by 0.02.

Energy efficiency

6. Solid concrete slab includes concrete beam and infill floors and concrete precast permanent formwork panels. For the purposes of calculating the Total R-Value of a floor, the R-Value attributable to an in-slab or in-screed heating or cooling system is ignored.
7. Where an airspace is filled, the R-Value listed for the airspace must be deducted from the Total R-Value of the floor construction.

Part J2

* * * * *

The content of [Part J2](#), which existed in NCC 2016 has been removed. The Part number [Part J2](#) has been retained so as not to change the numbering of the current NCC from that of NCC 2016.

Part J3 Building sealing

Deemed-to-Satisfy Provisions

J3.0 Deemed-to-Satisfy Provisions

Intent

To clarify that the requirements of [JP1](#) will be satisfied if a building complies with [Parts J1](#) to [J8](#).

See comments for Deemed-to-Satisfy Provisions of [J0.0](#).

J3.1 Application of Part

Intent

To clarify that the Deemed-to-Satisfy Provisions of [Part J3](#) do not apply to certain buildings and areas within certain buildings.

[J3.1](#) does not apply where the only conditioning is provided by an evaporative cooler or to openings necessary for the safe operation of a gas appliance.

A building that is conditioned by heating or refrigerative cooling needs to be sealed to conserve energy but one that is conditioned by evaporative cooling does not need to be sealed as windows or doors would need to be opened anyway in order to provide the relief for the ventilation air. However, if the building is in climate zones 4, 6, 7 or 8, or has a refrigerative cooler, then it has to be sealed because of the likelihood of heating during colder periods or to avoid the loss of cooled air when the refrigerated cooler is running.

The Deemed-to-Satisfy Provisions of [Part J3](#) do not apply to Class 8 electricity network substations as these buildings are not required to be air-conditioned for the purposes of [Section J](#). See the definition for air-conditioning. The air-conditioning systems of these buildings are instead designed to maintain the efficient operation of sensitive electrical equipment.

Ventilation for safe operation of a gas appliance is not covered by the NCC, but is addressed by other legislation. Appropriate ventilation for gas appliances can be obtained from the relevant legislation, reference standards and product installation manuals.

Unique to this Part is that as air-conditioned buildings are often pressurised by the introduction of outside air through a mechanical supply system, it may not be necessary to seal the building to the same degree as for an un-pressurised building.

J3.2 Chimneys and flues

Intent

To provide energy efficiency requirements to chimneys and flues.

The requirements of this Part are to be read in conjunction with the fire safety requirements in [Part G2](#).

A solid-fuel burning device is a heater that burns material such as timber, coal and the like. This provision does not apply to gas and liquid fuel burning devices.

J3.3 Roof lights

Intent

To provide energy efficiency requirements for the sealing of roof lights.

Roof lights that are openable must be sealed when closed in order to restrict the loss of conditioned air to the outside environment. It is assumed that most of the habitable rooms in residential type buildings in the cooler climate zones will be heated by installed or portable heaters. However if a non-habitable room is conditioned, either cooled or heated, then it must also be sealed. For the hotter climate zones, the roof lights need be sealed only if conditioning is being installed.

J3.4 Windows and doors

Intent

To provide energy efficiency requirements for the sealing of windows and doors.

An external door opening to a conditioned space must also have a device to prevent significant amounts of conditioned air being continuously lost. This only applies to conditioned spaces greater than 50 m². Devices that may be installed to comply with this requirement may include an airlock, self-closing door, or revolving door. Provisions for people with a disability should also be considered when selecting the device.

There are a couple of exemptions to these requirements, such as for roller shutter doors or the like, that are used for out-of-hours security purposes only, i.e. when conditioning is not operating. Another exemption has been granted for the main entrance to a café, restaurant or open front shop that has a 3 m non-conditioned zone. Where staff are carrying trays of food or drink it may be unsafe to require an airlock, self-closing door or sliding door.

J3.5 Exhaust fans

Intent

To provide energy efficiency requirements for the sealing of exhaust fans.

The sealing of exhaust fans applies to the same spaces and in the same climate zones as described for roof lights. It also only applies to “miscellaneous” exhaust fans, such as smaller fans used for domestic kitchen exhaust. The provisions do not apply to smoke exhaust fans and the like. The term “miscellaneous” is comparable with the use of this term in AS 1668.1 for certain air-handling systems.

A miscellaneous exhaust fan is considered to be adequately sealed if it is fitted with a self-closing damper or similar sealing device.

J3.6 Construction of roofs, walls and floors

Intent

To provide energy efficiency requirements for the sealing of roofs, walls and floors.

The sealing of roofs, walls and floors applies to the same spaces and in the same climate zones as described for roof lights. For the purposes of [J3.6](#), a suitable seal includes expanded foam, rubber compressible strip, caulking or other gap filling material.

The acceptable solution of a “close fitting internal lining system” is considered to include an allowance for minimum gaps in internal linings for thermal movement at wall, floor and ceiling junctions.

J3.7 Evaporative coolers

Intent

To provide energy efficiency requirements for the sealing of evaporative coolers when not in use.

Similarly to exhaust fans, an evaporative cooler represents a large opening in the building envelope. This opening needs sealing when the evaporative cooler is not in use, such as in the winter when a heating system may be operating.

Part J4

* * * * *

The content of [Part J4](#), which existed in BCA 2009, has been removed. The Part number [Part J4](#) has been retained without text so as not to change the numbering of the current BCA from that of BCA 2009.

Part J5 Air-conditioning and ventilation systems

Deemed-to-Satisfy Provisions

J5.0 Deemed-to-Satisfy Provisions

Intent

To clarify that [JP1](#) will be satisfied if compliance is achieved with [Parts J1 to J8](#).

See comments for Deemed-to-Satisfy Provisions of [J0.0](#).

J5.1 Application of Part

[Part J5](#) generally contains minimum energy efficiency requirements for the major energy consuming components of heating, ventilation and air-conditioning systems (HVAC) used in buildings.

Class 8 electricity network substations are exempted from [Part J5](#). These substations commonly operate mechanical ventilation or air-conditioning 24 hours a day to serve high voltage equipment, so manual override or specific design features for energy efficiency could be hazardous. See definition of “air-conditioning” in [Schedule 3](#).

It should be noted that the NCC cannot regulate operational matters such as the set point for temperature control devices during the occupation of buildings. It can only require that temperature control devices be installed.

Note that [Part J5](#) is about air-conditioning units and systems. So, the applicable floor area is only that of the space served by the air-conditioning unit or system, and does not include non-conditioned corridors, toilets, plant rooms and the like.

J5.2 Air-conditioning system control

Intent

To set the minimum control requirements for air-conditioning systems and components.

[J5.2](#) is about the control requirements for air-conditioning systems so that the consumption of energy is limited.

[J5.2\(a\)\(i\)](#) requires controls to deactivate the air-conditioning system when the area is not occupied and is intended to only apply where the building or part of a building served by the air-conditioning system is unoccupied. For example, if an air-conditioning system serves a whole building, it is only required to be capable of being deactivated when the whole building is unoccupied. Similarly, if an air-conditioning system only serves a single floor of a building, the system must be capable of being deactivated when that part of the building is unoccupied. It is likely this clause will require the operational arrangements to be designed on logical building areas and segments.

[J5.2\(a\)\(ii\)\(A\)](#) outlines that when one space has different thermal characteristics to another space, and both are conditioned by the same air-conditioner, it is necessary to provide separate temperature control devices. A suitable location of the temperature control devices may be in the ductwork supplying the different spaces or the air volume dampers.

For example, consider the differing thermal characteristics between a south and east facing room due to the differing solar gains received. If the temperature sensor is in the east facing room it may activate a higher level of cooling than the south facing room may require. This may result in the south facing room being cooler than desired. An additional temperature control device will allow separate control of the space, facilitating reduced energy use.

[J5.2\(a\)\(ii\)\(B\)](#) requires the temperature control of the air-conditioning system not depend on mixing heated and cooled air streams that have been actively conditioned by the plant. This requirement allows the air-conditioning system to use no more energy than is necessary.

[J5.2\(a\)\(ii\)\(C\)](#) contains restrictions on reheating the supply air. These requirements are intended to encourage the grouping of areas with similar loads (heating and cooling demand), rather than sub-cooling all the supply air and reheating excessively to achieve the desired temperature.

[J5.2\(a\)\(ii\)\(C\)\(aa\)](#) outlines that where a separate temperature control device is provided to reheat the air, then at the full supply air rate for the space, it must not increase the supply air temperature by more than 7.5 K, as there are more cost effective solutions. The 7.5 K limit on temperature rise allows for some trim heating of cold air supply but within reasonable limits.

[J5.2\(a\)\(ii\)\(C\)\(bb\)](#) outlines that the allowable temperature rise can be determined by using an inverse relationship between allowable temperature rise and supply air rate. If, during the reheating, the supply air rate is also reduced then the temperature rise can be proportionally increased above 7.5 K at the same rate that the supply air rate has been reduced.

Energy efficiency

For example, the reheat temperature could be increased to 10 K when the supply air rate is reduced by 25% or increased to 15 K if the supply air rate is reduced by 50%.

J5.2(a)(iii) requires outdoor air economy cycles to be provided where they can cost-effectively provide free cooling, however an area needing humidity control is exempt. Outdoor air economy cycles are not required in climate zone 1.

In this clause, the total air flow rate of each airside component means the airflow of each air-conditioner serving a space, not the combination of all the units serving a space because an outdoor air economy cycle is cost effective only in a larger unit.

Outdoor air economy cycles can be cost effective particularly in a building such as a Class 6 restaurant or café with a low occupancy. However, there may be situations where the outdoor air required by **Part F4** may be so great that an outdoor air economy cycle would admit only a small additional amount of outdoor air. The added cost of dampers and controls may not be justified for energy savings returned, so a performance based solution may be more appropriate in these circumstances.

An exemption is granted to applications that require humidity control. It is considered the additional cost and energy use of humidification or activation of a dehumidification plant offsets any benefit of free cooling from outdoor air economy cycle. These applications may include, but are not limited to, a frozen food section of a supermarket, a laboratory or a paper manufacturer's factory.

J5.2(a)(iv) requires the water flow through major items such as boilers and chillers to be stopped when the item is not needed, usually by an automatic valve. This will reduce the amount of water being circulated and the pump energy needed, as well as thermal loss through the additional components like piping. This requirement is intended to reduce pump energy to its minimum level.

J5.2(a)(v) outlines that a variable speed fan must be used when the supply air quantity is capable of being varied. This is because a variable speed fan is a more energy efficient method of reducing energy consumption than throttling the air supply with dampers. A unitary air-conditioning system is exempt.

J5.2(a)(vi) requires the air-conditioning unit or system to stop when a door to a balcony, patio or courtyard of a sole-occupancy unit of a Class 3 building is open for more than 1 minute. This can be achieved by an electric power micro-switch on the door. The 1 minute timing is to allow for people to open and close the door without the air-conditioning stopping and starting each time. However, if the door is left open for more than 1 minute, it ensures that the air-conditioning does not continue to operate and leak conditioned air.

J5.2(a)(vii) It is essential that air-conditioning systems have coordinated control from central plant through to room controls. This is what is meant by the term "direct controls", that the information comes directly from the components within the building. This ensures that it is possible to regulate the operation and set-points of central plant in coordination with the needs of the building, rather than operating central services as a continuous provision that can be drawn on.

J5.2(a)(viii) The inclusion of a minimum dead band between heating and cooling reflects the significant benefit that this can have for energy efficiency. It is noted that many buildings routinely use a 2°C dead band; the selection of a lower figure reflects the fact that this wider dead band does not suit all spaces.

J5.2(a)(ix) effectively requires the provision of devices that enable balancing of flows in the system. Systems without balancing equipment have less capability for successful variable flow operation.

J5.2(a)(x) ensures that the system can be shut off floor to floor or in large spaces in the event of different hours of operation. Independently operating relates to the space served, not the air-conditioning equipment.

J5.2(a)(xi) Chillers and boilers all have the potential for improved efficiency operation when operated at variable temperature, which can be implemented via a control strategy also known as a temperature reset. Chiller COP improves at a rate of 2-5% per 1°C increase in chilled water temperature; heat pump COPs improve at around 2% per 1°C; and condensing boilers improve efficiency markedly when the return hot water temperature drops below 53°C. Distribution losses for a chilled water system reduce by around 10% for every 1°C increase in average chilled water temperature; this figure is around 2% per 1°C for hot water.

J5.2(a)(xii) requires any motorised outside air or return dampers to close when the system is deactivated. It does not require that the dampers be motorised, only that they close if motorised dampers are installed. This requirement is to reduce the infiltration of unconditioned outdoor air via this path when the system is not in use, and so reduce the start-up load when the system is next required to operate.

J5.2(b) There is an increasing trend towards the use of supplementary air-conditioning systems, especially in offices, where tenants are seeking to achieve far higher levels of occupant density than was allowed for in the building design. These supplementary systems often operate in parallel with the primary building air-conditioning, creating a significant risk of heating/cooling conflict between the systems. To avoid this, it is necessary for all systems serving a single space to have coordinated control and use the same temperature sensing equipment.

J5.2(c) specifies the requirements for time switch controlling of power supply to air-conditioning systems. The intent is to reduce unnecessary energy consumption attributable to the system when it is not being used.

Air-conditioning systems with a capacity greater than 2 kW and heaters greater than 1 kW must be provided with time

Energy efficiency

switches that can activate and de-activate the respective system.

J5.2(c)(ii) specifies the required capability of the time switch.

J5.2(c)(iii) grants exemptions for time switches for an air-conditioning system serving a single sole-occupancy unit of a Class 2, 3 or 9c building or a Class 4 part of a building. This exemption recognises that the temperature will be controlled by the occupants. There is also an exemption for a building where air-conditioning is needed for 24 hour occupancy such as a hospital emergency room.

It should be noted that the BCA cannot mandate operational or administrative matters such as the pre-programmed times for time switches, nor would it be practical to do so. It can only require that time switches be installed.

J5.3 Mechanical ventilation system control

Intent

To set the minimum control requirements for mechanical ventilation systems and components.

J5.3(a) is about the control requirements for mechanical ventilation systems so that the consumption of energy is limited. As outlined in J5.3(a)(i) the mechanical ventilation system may be part of an air-conditioning system described in J5.2 or may be a separate mechanical ventilation system such as a carpark mechanical ventilation system. The requirements do not apply to a mechanical ventilation system that serves only one sole-occupancy unit of a Class 2 building or Class 4 part of a building.

J5.3(a)(i) is intended to only apply when the building or part of a building served by the mechanical ventilation system is unoccupied. For example, if a mechanical ventilation system serves a whole building it is only required to be capable of being deactivated when the whole building is unoccupied. Similarly, if a mechanical ventilation system only serves a single floor of a building, the system must be capable of being deactivated when that part of the building is unoccupied.

J5.3(a)(ii) contains specific requirements for when a mechanical ventilation system serves a conditioned space.

J5.3(a)(ii)(A) nominates that where the airflow of a ventilation system exceeds the outdoor airflow referenced in Table J5.3, a modulating control or energy reclaiming system must be installed in accordance with the table.

J5.3(a)(i)(B) requires that the outdoor air requirement of Part F4 not be exceeded by more than 20% when serving a conditioned space.

A number of exemptions from these requirements are provided:

- The first exemption in J5.3(a)(ii)(B)(aa) is for free cooling provided as part of an outside air economy cycle.
- J5.3(a)(ii)(B)(bb) exempts situations where additional outdoor air to balance exhaust ventilation is required by Part F4. This may occur in areas such as toilets or bathrooms which have high exhaust rates to remove contaminated air or to balance process exhausts such as those used in a health-care building or a laboratory. In such situations, an equivalent level of supply air may be required to balance the system.
- The final exemption in J5.3(a)(ii)(B)(cc) is for situations where an energy reclaiming system that preconditions all the outside air is used.

J5.3(a)(iii) requires that, where possible, larger mechanical ventilation systems have a variable speed fan.

J5.3(b) contains requirements for miscellaneous exhaust systems. Examples of these types of systems include kitchen hoods, laundry hoods and fume hoods. Consideration should also be given to situations where safety is an issue, such as the exhaust from a chemical storage cabinet. Likewise, it may be more appropriate that fume hoods in some situations operate on a reduced flow while in other situations operate at full flow. A Performance Solution may be considered more appropriate in such situations.

A miscellaneous exhaust system with an air-flow rate of more than 1000 L/s that is associated with equipment with a variable demand, must be capable of stopping the motor when not needed to reduce energy consumption.

The requirements do not apply to a miscellaneous exhaust system serving a sole-occupancy unit in a Class 2, 3 or 9c building.

There is an exemption for situations where the exhaust system must balance the intake of outside air required for ventilation. The exemption recognises that the required minimum ventilation rates take precedence over energy efficiency measures.

J5.3(c) requires that carpark exhaust systems have a carbon monoxide monitoring system in accordance with AS 1668.2.

J5.3(d) specifies the requirements for time switch controlling of power supply to mechanical ventilation systems. The intent is to reduce unnecessary energy consumption attributable to the system when it is not being used.

Mechanical ventilation systems with an air flow rate of more than 1000 L/s are to be provided with time switches in accordance with Specification J6 that can activate and de-activate the respective system.

J5.3(d)(ii) contains the required capability of the time switch.

Energy efficiency

J5.3(d)(iii)(A) grants exemptions for time switches for a mechanical ventilation system serving a single sole-occupancy unit of a Class 2, 3 or 9c building or a Class 4 part of a building.

There is also an exemption in J5.3(d)(iii)(B) for a building where mechanical ventilation is needed for 24 hour occupancy such as a hospital emergency room or factory.

J5.4 Fan systems

There are two options to demonstrate that a fan system that forms part of an air-conditioning system is compliant with J5.4. The first option is to demonstrate that each of the individual components of a fan system are individually more efficient than the values specified in J5.4. The second option is to demonstrate that the fan system as a whole is more efficient than a system that is designed meeting the individual component requirements.

The component level compliance option is intended to allow for a simpler method to demonstrate compliance, allowing for a relatively simple comparison against a Deemed-to-Satisfy efficiency value for each component of the fan system. The system-level compliance option is intended to allow for increased flexibility when design constraints prevent the individual component level metrics from being met, without necessitating the use of a JV3 calculation or another Performance Solution.

J5.4(a) outlines these two options – demonstrating compliance at either a fan system component level or a whole-of-fan-system level.

J5.4(a)(i) is the option for component-level compliance and requires compliance with J5.4(b), (c), (d) and (e).

J5.4(a)(ii) outlines the option for whole-of-system compliance, where the fan motor input power per unit of flowrate (e.g. W/L/s) of the fan in the system as per the design must be lower than the fan motor input power per unit of flowrate if the system was designed in accordance with J5.4(b), (c), (d) and (e). If a pump system as a whole is compliant with J5.4(a)(ii), it does not need to comply with J5.4(b), (c), (d) or (e).

J5.4(b)(i) nominates the required efficiency of a fan at full load in a system with a static pressure of not more than 200 Pa.

J5.4(b)(ii) nominates the required efficiency of a fan at full load. The clause uses a regression formula, based on the fan input power, minimum fan performance grade and two regression coefficients to disallow the use of an inefficient fan in an air-conditioning system. Table J5.4a, Table J5.4b and Table J5.4c provide the minimum fan performance grade and regression coefficients based on fan type, fan installation arrangement and fan power.

J5.4(b)(iii) exempts fans that are required to be explosion proof from the requirements of J5.4(b)(i) and J5.4(b)(ii).

J5.4(c)(i) nominates that the average pressure drop in the index run of a fan system must not exceed 1 Pa/m for flexible ductwork and straight segments of rigid ductwork. For the purpose of this calculation, the pressure drop of flexible ductwork sections may be calculated as if the flexible ductwork is in a straight configuration.

J5.4(c)(ii) limits flexible ductwork to a maximum of 6 m in length in any duct run.

J5.4(c)(iii) disallows ductwork bends that have a smaller effective diameter than the upstream duct section they are connected to. Reducing bends are permissible.

J5.4(c)(iv) requires rigid ductwork bends of 90 degrees or less (e.g. a sharp 45 degree bend) include turning vanes, except where turning vanes would present a fouling risk or where it is a long radius bend in accordance with AS 4254.

J5.4(d) specifies the maximum allowable pressure losses of components in a ductwork system. An acceptable Performance Solution may be to demonstrate that where a pressure loss of a component exceeds the allowance provided in J5.4(d), this is compensated for by another section of the duct run which is lower than the allowance by an equivalent amount. Note that the allowances for grilles do not include any balancing dampers that may be included within the grille.

J5.4(e) provides exemptions from the other clauses in J5.4.

J5.4(e)(i) exempts fans in unducted air-conditioning systems with a supply air capacity of less than 1000 L/s.

J5.4(e)(ii) exempts smoke spill fans, except where they are also used for air-conditioning or ventilation. Smoke spill fans will rarely operate and therefore represent a very small amount of actual energy usage.

J5.4(e)(iii) exempts the power for process-related components.

J5.4(e)(iv) exempts kitchen exhaust systems.

J5.5 Ductwork insulation

Ductwork and fittings in an air-conditioning system need to be insulated to reduce energy loss. The insulating requirements do not apply to ventilation ductwork where the air is not heated or cooled.

J5.5(a)(i) outlines that insulation must comply with the requirements of AS/NZS 4859.1.

J5.5(a)(ii) specifies the minimum material R-Value of ductwork and fittings.

Note that the insulation levels in Table J5.5 are minimum material R-Values of the added insulation and are based on the location and climate zone of the installed ductwork and fittings.

Energy efficiency

J5.5(b) outlines specific requirements of the insulation, such as (i), that the insulation must be protected against the effects of weather and sunlight, which will likely reduce its insulating properties over time.

J5.5(b)(ii) requires insulation to be installed so that it abuts adjoining insulation to form a continuous barrier as any gaps in the insulation allow heat loss or gain. The insulation should also maintain its position and thickness other than at flanges and supports as any compression of insulation can reduce its effectiveness.

J5.5(b)(iii)(A) requires a vapour barrier to be installed around the insulation on ductwork that conveys cold air to assist in the control of condensation resulting from the cold surface. Without a vapour barrier, the likelihood of condensation forming increases. Condensing moisture can saturate the insulation, thereby reducing its effectiveness and causing it to deteriorate. J5.5(b)(iii)(B) states that where the vapour barrier is used as a membrane, it must overlap by 50 mm and be bonded or taped together to ensure the vapour barrier membrane can function as intended.

J5.5(c) exempts a number of situations where ductwork and fittings do not need to be in accordance with the requirements of J5.5(a) as it may be impractical or pointless to do so.

J5.5(c)(i) exempts ductwork and fittings located within the only or last room served from being insulated on the basis that the heating or cooling effect is intended for that room anyway. If a room where the ductwork is not insulated is sub-divided then insulation will need to be added to the ductwork that passes through the first room to serve the second room. This needs to be considered if the exemption is applied to a part of a building or storey likely to be sub-divided as part of a fit-out.

J5.5(c)(ii) exempts fittings that form the interface with the conditioned space such as air registers, diffusers, outlets, grilles and the like, as there would be minimal heat transfer occurring.

J5.5(c)(iii) exempts return air ductwork in, or passing through, a conditioned space from meeting the minimum insulation requirements as there would be no heat transfer across the ductwork.

J5.5(c)(iv) exempts ductwork containing unconditioned outside air or exhaust air ductwork where the air is to be discarded anyway. There would be no benefit gained, in terms of reducing energy consumption, by requiring insulation to be installed on this ductwork.

J5.5(c)(v) exempts the floor of an in-situ air handling unit from the insulation requirements of J5.5(a).

J5.5(c)(vi) exempts air-conditioning equipment that complies with MEPS. Note that air-handling ductwork must also comply with Clause 5 of Specification C1.10.

The application of the ductwork insulation requirements are shown in the following example.

Figure J5.5 Example – Application of ductwork insulation

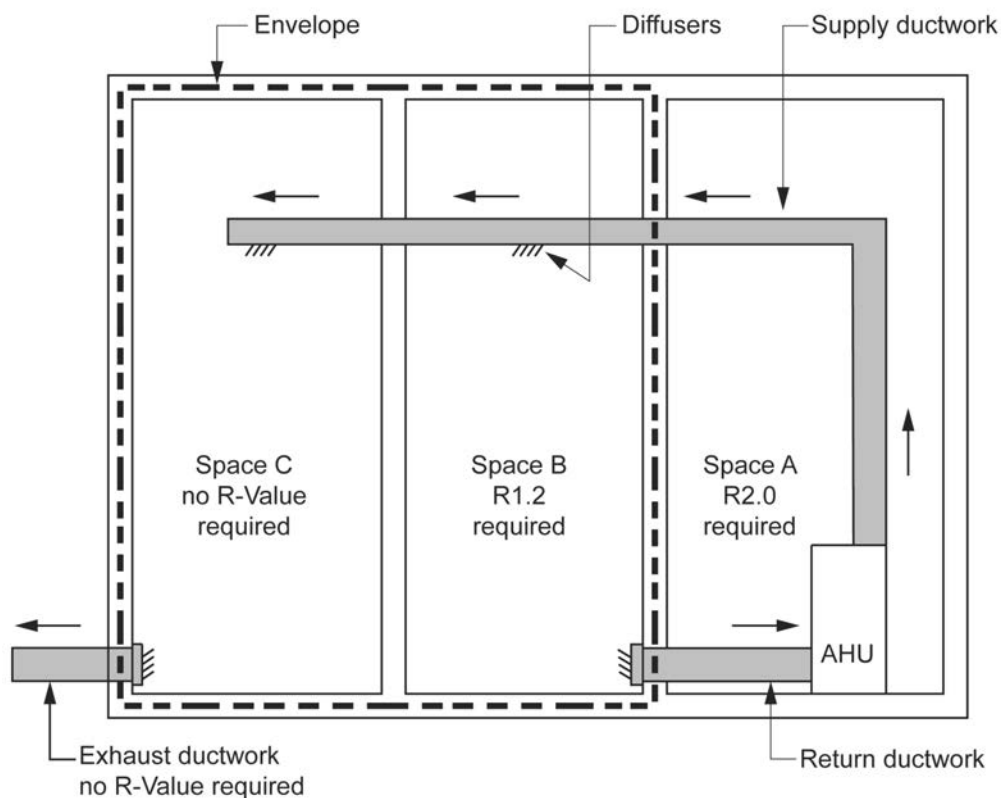

Energy efficiency

In this example, the building is located in climate zone 5 and the ductwork is greater than 3 m in length.

Space A is not conditioned; therefore insulation must be installed to the supply and return ductwork with a minimum R-Value of R2.0 as per [Table J5.5](#).

Space B is a conditioned space; therefore insulation with a minimum added R-Value of R1.2 from [Table J5.5](#) is required to be installed on the supply ductwork. No insulation is needed for the return ductwork in Space B as it is exempted by [J5.5\(c\)\(iii\)](#).

Space C is a conditioned space. Since it is the last room served by the system the insulation requirements of [J5.5\(a\)](#) do not apply to the ductwork.

In Space B and C the diffuser forms the interface with the conditioned space and is therefore exempt from the insulation requirements of [J5.5\(a\)](#) by [J5.5\(c\)\(ii\)](#).

The exhaust ductwork is exempt from the insulation requirements of [J5.5\(a\)](#) by [J5.5\(c\)\(iv\)](#).

Note that the requirements of [Section C - Fire resistance](#) may also apply.

[J5.5\(d\)](#) outlines that for the purposes of this Specification, 'fittings' includes passive or static components of a ductwork system and excludes active components of a ductwork system such as those used in an air-handling unit.

This means passive or static components of a ductwork system must meet the insulation requirements of this section and may include items such as plenums, bends, branches, transitions, reducers, offsets, spigots, cushion heads, attenuators and fixed air balance dampers.

Active components of a ductwork system are exempt from the insulation requirements of this section. This exemption recognises that there are practical difficulties applying insulation to components that move or where access is regularly required.

Active components may include Variable Air Volume (VAV) boxes, electric duct heaters, actuated volume control dampers, access panels and doors, fire and smoke dampers, fans or humidifiers.

J5.6 Ductwork sealing

Air-conditioning ductwork has joints, and unless sealed these joints will allow heated or cooled air to escape. To limit this heat loss or gain, ductwork must be sealed with adhesives, mastics, sealants, gaskets or the like in accordance with AS 4254 Parts 1 and 2 for the static pressure in the system. AS 4254 is the standard covering ductwork for air-handling systems in buildings. These requirements do not apply to ventilation ductwork where the air is not heated or cooled.

The requirements only apply to duct systems with a capacity of 3000 L/s or greater. The requirements do not apply to ductwork in the space being conditioned or the last room served by the system, as the air is intended for that space anyway.

The duct leakage tests of clause 2.2.4 of AS 4254.2 are included in this requirement. The key purpose of this is not so much to deal with minor leakage but to ensure that there are no major leaks such as uncapped spigots and similar in the system. Construction errors of this nature can cause leakage rates in excess of 20% in some systems, severely compromising system performance.

J5.7 Pump systems

There are two options for demonstrating that a pump system that forms part of an air-conditioning system is compliant with [J5.7](#). The first option is to demonstrate that each of the individual components of a pump system are individually more efficient than the values specified in [J5.7](#). The second option is to demonstrate that the pump system as a whole is more efficient than a system that is designed to meet the individual component requirements.

The component level compliance option is intended to allow for a simpler method to demonstrate compliance, allowing for a relatively simple comparison against a Deemed-to-Satisfy efficiency value for each component of the pump system. The system-level compliance option is intended to allow for increased flexibility when design constraints prevent the individual component level metrics from being met, without necessitating the use of a [JV3](#) calculation or another Performance Solution.

[J5.7\(a\)](#) outlines these two options – demonstrating compliance at either a pump system component level or a whole-of-pump-system level.

[J5.7\(a\)\(i\)](#) is the option for component-level compliance and requires compliance with [J5.7\(b\)](#), [\(c\)](#) and [\(d\)](#).

[J5.7\(a\)\(ii\)](#) outlines the option for whole-of-system compliance, where the pump motor power per unit of flowrate (e.g. W/L/s) of the pump in the system as per the design must be lower than the pump motor power per unit of flowrate if the system was designed in accordance with [J5.7\(b\)](#), [\(c\)](#) and [\(d\)](#). If a pump system as a whole is compliant with [J5.7\(a\)\(ii\)](#), it does not need to comply with [J5.7\(b\)](#), [\(c\)](#) or [\(d\)](#).

[J5.7\(b\)](#) nominates the efficiency requirements of circulator pumps that form part of an air-conditioning system. [J5.7\(b\)](#) is a requirement if the component-level compliance option of [J5.7\(a\)\(i\)](#) is used. The clause applies to glandless impeller pumps with a rated hydraulic power output of less than 2.5kW, used in a closed loop system. The clause nominates that

Energy efficiency

the pump must have an energy efficiency index of less than or equal to 0.27 in accordance with European Union Commission Regulation No. 622/2012.

[J5.7\(c\)](#) nominates the efficiency requirements of other pumps that form part of an air-conditioning system. [J5.7\(c\)](#) is a requirement if the component-level compliance option of [J5.7\(a\)\(i\)](#) is used. The clause applies to pumps not covered by [J5.7\(b\)](#). The clause nominates that the pump must have a minimum efficiency index of greater than or equal to 0.4 in accordance with European Union Commission Regulation No. 547/2012.

[J5.7\(d\)](#) nominates the maximum allowable pressure losses of straight segments of pipework that form part of an air-conditioning system. [J5.7\(d\)](#) is a requirement if the component-level compliance option of [J5.7\(a\)\(i\)](#) is used.

[J5.7\(d\)\(i\)](#) nominates the allowable pressure losses attributable to straight segments of pipework in non-distributive pipework systems. A non-distributive pipework system is a pipework system that does not have branches and has a constant flowrate through the entire pipe network. Pressure losses for constant speed systems are nominated in [Table J5.7a](#) and pressure losses for variable speed systems are nominated in [Table J5.7b](#).

[J5.7\(d\)\(ii\)](#) nominates the allowable pressure losses attributable to straight segments of pipework in distributive pipework systems. Pressure losses for constant speed systems are nominated in [Table J5.7c](#) and pressure losses for variable speed systems are nominated in [Table J5.7d](#).

[J5.7\(e\)\(i\)](#) specifies that the requirements of [J5.7\(d\)](#) do not apply to valves and fittings, as these are largely determined by functional requirements of the system.

[J5.7\(e\)\(ii\)](#) specifies that the requirements of [J5.7\(d\)](#) do not apply to pipework with a velocity of 0.7 m/s or less.

J5.8 Pipework insulation

[J5.8](#) requires piping, vessels, heat exchangers and tanks that contain heating and cooling fluids that are part of an air-conditioning system to be insulated. Heating fluids include heated water, steam and condensate and cooling fluids include refrigerant, chilled water, brines and glycol mixtures, but does not include condenser cooling water. Piping, vessels, heat exchangers and tanks that are covered by MEPS are exempt from these requirements.

Condenser cooling water is exempt from the minimum insulation requirements of this clause due to the limited temperature difference between the piping contents and the surrounding space. This means there would likely be small energy savings achieved compared to the costs of insulation in these circumstances. However, insulation may be installed for reasons other than energy efficiency such as for acoustics, or to minimise the risk of condensation forming.

[J5.8\(a\)\(i\)](#) states that insulation must comply with the requirements of AS/NZS 4859.1 which covers materials for the thermal insulation of buildings - general criteria and technical provisions.

[J5.8\(a\)\(ii\)](#) and [\(iii\)](#) outline that insulation requirements are located in—

- for piping of heating and cooling fluids: [Table J5.8a](#); and
- for vessels, heat exchangers and tanks: [Table J5.8b](#).

[J5.8\(a\)\(iv\)](#) outlines that insulation requirements apply to pressure relief piping within 500 mm of the connection to the air-conditioning system.

Note the R-Value is that of the insulation and not the Total R-Value of the pipe, air film and insulation. This approach is similar to ductwork insulation. Where piping has a significant inherent R-Value, it may be subtracted from the material R-Value required. However, the inherent R-Value of most piping materials is not sufficient to satisfy the requirements in [Table J5.8a](#).

The insulation types in the following table are typical examples of materials that can be used to insulate piping and are provided for guidance only. The R-Values are calculated in accordance with AS/NZS 4859.1 as per the requirement in [J5.8\(a\)\(i\)](#) and averaged over a number of nominal pipe diameters.

Insulation	R-Value
13 mm of closed cell polymer	0.6
19 mm of closed cell polymer	0.9
25 mm of closed cell polymer	1.3
25 mm of glasswool	1.3

The insulation values in [Table J5.8a](#) are based on a nominal diameter of the water piping. The single required R-Value for each pipe diameter is intended to allow for straightforward installation on-site and compliance to be achieved.

[Table J5.8b](#) specifies the minimum insulation requirements for vessels, heat exchangers and tanks with the values specified based on the likely temperature of the fluid.

[J5.8\(b\)\(i\)](#) requires insulation to be protected from the effects of weather and sunlight, which may reduce its insulating properties. This protection may be achieved by ensuring that the insulation is enclosed in protective sheathing such as formed metal sheeting, external grade plastics or other similar material.

Energy efficiency

J5.8(b)(ii) requires insulation to be able to withstand the temperatures within the piping, vessel, heat exchanger or tank, otherwise degradation of the insulation's thermal performance may occur.

J5.8(c) requires insulation to be protected by a vapour barrier if the piping, heat exchanger or tank contains a cooling fluid. This is to reduce the likelihood of condensation problems arising that are created by the internal temperature of the piping, heat exchanger or tank being below the dew point of the external air.

J5.8(d) outlines circumstances when piping, vessels and heat exchangers are exempt from meeting the requirements of J5.8(a) and (b). This includes where it is located within the last space being heated or cooled as the heating or cooling effect is intended for that space anyway, or it is in a slab or panel that is specifically designed as a heating or cooling system, such as an in-slab or in-screed heating or cooling system. This is because the insulation would contradict the aim of the heating or cooling from the piping. J5.8(a)(iii) and (iv) exempt piping that is supplied as part of an item of plant such as a chiller or boiler or inside an item of plant such as an air-handling unit, fan-coil unit or the like.

J5.9 Space heating

The energy sources that may be used for heating a space directly are listed in J5.9(a) which also specifies that all forms of heating described in J5.9(a)(i) to (a)(v) can be used in combination so as not to restrict heating to only one type. This clause recognises a combination of heating options may be the most appropriate and cost effective heating solution and may include a limited amount of electric resistance heating.

J5.9(a)(iv) permits reclaimed heat from another process such as from a refrigeration plant, a co-generation plant, and bio-fuels to be used and this reclaimed energy can be used in conjunction with one or more heaters allowed under J5.9.

Electric heating can be used in specific circumstances only as outlined in J5.9(a)(v)(A) which allows a small amount of electric resistance heating, up to 10 W/m² for climate zone 1 and 40 W/m² for climate zone 2, for the floor area of the conditioned space. The small allowances recognise the likely limited heating required for these mild climates.

J5.9(a)(v)(A)(cc) permits larger electric heating allowances in situations where reticulated gas is not available at the allotment boundary, recognising the likely limited heating options in areas where natural gas is not readily available. The maximum values are specified in Table J5.9 and are again climate zone based to recognise the limited heating required in temperate climates, compared to cool climates.

J5.9(a)(v)(B) allows a further exemption for relatively small electric heaters in climate zones 1 to 5 if the annual energy consumption for this heating is not more than 15 kWh/m² of the floor area of the conditioned space.

J5.9(a)(v)(C) places limits on the amount of reheat allowed for an in-duct heater.

J5.9(b) permits a small 1.2 kW electric heater in a bathroom of a Class 2, Class 3 or Class 9c aged care building. Typically, this would include small electric heaters such as a 3-in-1 heater, exhaust fan and light system. The heater must be fitted with a means to ensure it will not run excessively when the bathroom is not in use.

J5.9(c) is specifically for fixed outdoor heating and cooling appliances and requires that the appliance must be capable of automatic shutdown, which may be achieved by an outdoor temperature sensor, timer, motion detector or the like. This requirement aims to limit energy consumption when the service is not needed.

J5.9(d) specifies the efficiencies required for a gas fired heater that heats a space via water, such as a boiler. The minimum thermal efficiencies are based on the rated gas consumption of the boiler in terms of MJ/hour. There are a number of testing standards that can be used to demonstrate a unit's Gross Thermal Efficiency, including—

- BS 7190
- ANSI/AHRI 1500
- AS/NZS 5263.1.2.

Whatever the test used, it is important that the test conditions mirror the expected typical operating conditions. This is especially important in regard to condensing boilers, where the inlet/outlet temperature of water will greatly impact the overall efficiency.

J5.10 Refrigerant chillers

J5.10 covers the requirements for refrigerant chillers and specifies that a refrigerant chiller that is part of an air-conditioning system must have an energy efficiency ratio complying with MEPS and Table J5.10a or Table J5.10b for both full load and integrated part load. The tables are similar to tables in ASHRAE 90.1 2016. Table J5.10a contains higher full-load performance values, intended to be applicable to chillers which are more likely to operate at full load, while Table J5.10b contains higher part-load performance values, intended to be applicable to chillers which are more likely to operate at part load. A designer may choose whether to comply with Table J5.10a or Table J5.10b.

The energy efficiency ratio must be determined by testing in accordance with the American Air-Conditioning & Refrigeration Institute (AHRI) Standard AHRI 551/591. This standard requires chillers to be tested at full load and at a series of part loads, which are then integrated into a single number part-load efficiency.

Note that the use of flow and return temperatures applied during the testing of chillers to AHRI 551/591 (a 6°C flow and 12°C return) may not be appropriate to allow for a pumping system compliant with [J5.7](#).

Comparison to the European Union MEPS (EUROVENT)

The European Union (EU) has developed a Minimum Energy Performance requirement for chillers used within its borders: EU Eco-design Lot 21. For equipment certified under this scheme a Performance Solution, showing how the chiller compares to Deemed-to-Satisfy requirements of [J5.10](#), may be used with the approval of the local building control authority.

J5.11 Unitary air-conditioning equipment

A unitary air-conditioner is a modular factory assembled air-conditioning unit. These units are self-contained and include within the unit all the components for heating and/or cooling such as fans, controls, a refrigeration system, heating coil and sometimes the heater. Split systems, packaged air-conditioners, variable refrigerant flow and variable refrigerant volume air-conditioners are all types of unitary air-conditioners.

[J5.11\(a\)](#) states that unitary air-conditioning equipment with a capacity of less than 65 kW_r must have a minimum energy efficiency ratio when cooling complying with MEPS.

[J5.11\(b\)\(i\)](#) specifies the efficiency required for water-cooled packaged air-conditioning equipment.

[J5.11\(b\)\(ii\)](#) specifies the efficiency required for air-cooled packaged air-conditioning equipment.

AS/NZS 3823.1.2 has various test conditions so this clause requires the equipment to be tested at condition T1. This standard covers the performance of electrical appliances - air-conditioners and heat pumps, ducted air-conditioners and air-to-air heat pumps - testing and rating for performance.

J5.12 Heat rejection equipment

[J5.12\(a\)](#) outlines that the requirements for a fan, that is part of a cooling tower, closed circuit cooler or an evaporative cooler that is part of an air-conditioning system, are located in [Table J5.12](#). The maximum fan motor power allowed is dependent on the type of fan used.

The performance of cooling tower fans, closed circuit cooler fans and evaporative condenser fans can be determined using any nationally or internationally accepted standard. For example Cooling Technology Institute's (CTI) standard CTI STD-201RS(13) and Acceptance Testing Code (ATC) ATC-105(00), can be used to determine the performance of cooling tower fans. CTI STD-201RS(13) and ATC-105S(11) can be used for closed circuit cooler fans and ATC-106(11) can be used to determine the performance of evaporative condenser fans.

[J5.12\(b\)](#) states the requirements for a self-contained, air-cooled condenser fan motor that is part of an air-conditioning system. The fan motor must not consume more than 42 watts of fan motor power for each kW of heat removed from the refrigerant. The air-cooled condenser fan is used to cool refrigerant from its vapour phase to its liquid phase as part of the refrigeration cycle.

Air-cooled condensers, not part of a packaged air-conditioner or split unit as per the exemptions in [J5.12\(b\)\(i\)](#) and [\(ii\)](#), are typically associated with larger plant installations. The requirements of [J5.12\(b\)](#) are also not intended to capture a condenser covered by MEPS.

Part J6 Artificial lighting and power

Deemed-to-Satisfy Provisions

J6.0 Deemed-to-Satisfy Provisions

Intent

To clarify that [JP1](#) will be satisfied if compliance is achieved with [Parts J1](#) to [J8](#).

See comments for Deemed-to-Satisfy Provisions of [J0.0](#).

J6.1 Application of Part

[J6.2](#), [J6.3](#), and [J6.5\(a\)\(ii\)](#) do not apply to Class 8 electricity network substations. The safety of workers requires manual lighting controls for inspection and maintenance activities of hazardous high voltage equipment.

J6.2 Artificial lighting

Intent

To set the minimum requirements for the level of interior artificial lighting.

J6.2(a) - Sole-occupancy units of Class 2 buildings or a Class 4 part

There are two approaches available for the sole-occupancy units of residential buildings in [J6.2\(a\)\(i\)](#). They are a lamp power density approach or an illumination power density approach. The former is simpler while the latter provides considerably more flexibility for a dwelling with sophisticated lighting control systems. 5 W/m² for inside a dwelling is the criterion in both approaches.

Lamp power density is the simpler means of setting energy consumption at an efficient level for sole-occupancy units of Class 2 buildings or a Class 4 part of a building. It is a defined term and is calculated by adding the maximum power ratings of all the permanently wired lamps in a space and dividing this sum by the area of the space. With this approach there are no concessions for using timers, motion detectors or other control devices.

If the illumination power density approach is used the 5 W/m² can be increased by dividing it by the illumination power density adjustment factor in [Table 6.2b](#) where applicable. This more complex approach has been included as an increasing number of dwellings are using sophisticated control systems in order to reduce their energy consumption.

Lamps plugged into general purpose socket outlets are excluded through the definition of lamp power density and illumination power density because of the difficulty in regulating such portable appliances.

When illumination power density and one or more control devices are used, the adjustment factor is only applied to the space(s) served by the control device. The adjusted allowance for this space is then combined with the allowances for the remaining spaces using an area weighted average, which subsequently increases the allowance provided in [J6.2\(a\)\(i\)\(A\)](#) or [\(B\)](#).

The area of the space refers to the area the lights serve. This could be considered a single room, open plan space, verandah, balcony or the like, or the total area of all these spaces.

To comply with [J6.2\(a\)\(i\)](#), the design lamp power density or design illumination power density must be less than or equal to the allowance. Trading of allowances between [J6.2\(a\)\(i\)\(A\)](#) and [\(B\)](#) is not permitted.

[J6.2\(a\)\(i\)\(B\)](#) includes outdoor living spaces such as verandahs, balconies, patios, alfresco spaces or the like that are attached to a sole-occupancy unit of a Class 2 building or Class 4 part of a building.

[J6.2\(a\)\(iii\)](#) requires the power of the proposed installation to be used and may mean the light fittings be specified or some other administrative condition be applied.

[J6.2\(a\)\(iv\)](#) requires the less efficient halogen lamps to be separately switched from fluorescent lamps. This is because the halogens may not be needed all the time but would have to be on if they were controlled by the same switch as the more efficient fluorescent.

J6.2(b) - Buildings except for sole-occupancy units of Class 2 buildings or a Class 4 part

[J6.2\(b\)](#) covers other building classifications. Requirements for these types of buildings are more detailed than the requirements for sole-occupancy units of Class 2 buildings or a Class 4 part, in order to cater for the greater range of applications.

Energy efficiency

Where lamp power density or illumination power density may be used for sole-occupancy units in Class 2 buildings or a Class 4 part of a building, only illumination power density (IPD) can be used to measure compliance for all other applications.

Lighting in non-residential commercial buildings is progressively moving towards the use of LED lamps for general lighting and for special lighting. At present other lamps are available, but because of the shift to LED lamps for general lighting, the illumination power density levels in [Part J6](#) reflect this newer technology. The aggregated design illumination load is the maximum load in the lamp's operational cycle.

[J6.2\(b\)\(i\)](#) describes the process for determining the illumination power allowance for artificial lighting, however it does not apply to the sole-occupancy units of a Class 2 building or a Class 4 part of a building.

Illumination power density values

The maximum values in [Table J6.2a](#) have been derived on the basis of a lighting design complying with the recommendations of AS 1680 for the nature of the task, including an allowance for a safety margin in design and the physical limitation of placing a discrete number of fittings in a uniform array. The maintained illuminance will be designed to suit the use of the area and again is based on the illuminance levels in AS 1680 or an equivalent document from an overseas standards organisation. However, the levels are not being controlled by [Section J](#) of the BCA; only the power allowance for achieving the desired illuminance.

The following table shows how some of the illumination power density values correspond to the lighting levels of AS 1680. The allowance is for the power supply to the lighting.

The values have been generally set at a level that can be achieved with reasonable surface reflectances, direct (rather than indirect) lighting, and low loss control gear. The use of the space has also been taken into account. However, Performance Solutions, developed to the satisfaction of the local building control authority, can be used for spaces that have complex or specific lighting needs. AS 1680.1 includes scenarios of where it may be appropriate for higher illumination levels. Where higher illumination levels can be justified to the local building control authority, a Performance Solution based on the notes to [Table J6.2a](#) could be developed. Alternatively, energy saved by more efficient building services or through the installation of on-site renewable energy systems may also be used to increase the allowances for lighting, again subject to the approval of the local building control authority.

There are two levels for offices. General open areas that are lit to more than 200 lx may use 4.5 W/m². For offices lit to less than 200 lx, where task lighting is intended to supplement the general lighting, the maximum for the general lighting is only 2.5 W/m².

The table provides values based on the illuminance level.

Illumination power density values as they correspond to the lighting levels of AS 1680

Location	AS 1680 recommended illuminance, lx	Maximum illumination power density W/m ²
Auditorium, church and public hall	160	8
Board room and conference room	240	5
Carpark - general	40	2
Carpark – entry zone (first 15 m of travel)	800	11.5
Carpark – entry zone (next 4 m of travel) during daytime	160	2.5
Carpark – entry zone (first 20 m of travel) during night-time	160	2.5
Common rooms, spaces and corridors in a Class 2 building	160	4.5
Control room, switch room and the like – intermittent monitoring	160	3
Control room, switch room and the like – constant monitoring	240	4.5
Corridors	240	5
Courtroom	320	4.5
Entry lobby from outside building	160	9
Health-care – infants' and children's ward and emergency department	240	4
Health-care – examination room	400	4.5
Health-care – examination room in intensive care and high dependency ward	400	6
Health-care – all other patient care areas including wards and corridors	240	2.5

Energy efficiency

Location	AS 1680 recommended illuminance, lx	Maximum illumination power density W/m ²
Kitchen and food preparation areas	240	4
Laboratory - lit to 400 lx or more	400	6
Library – stack and shelving area	240	2.5
Library – reading room and general areas	320	4.5
Lounge area for communal use in a Class 3 or 9c building	240	4
Museum and gallery - circulation, cleaning and service lighting	240	2.5
Office – artificially lit to an ambient level of 200 lx or more	320	4.5
Office – artificially lit to an ambient level of <200 lx	160	2.5
Plant room where an average of 160 lx vertical illuminance is required on a vertical plane	160	4
Plant room with a horizontal illuminance target of 80 lx	80	2
Restaurant, café, bar, hotel lounge and a space for the serving and consumption of food or drinks	80	14
Retail space including a museum and gallery whose purpose is the sale of objects	160	14
School - general purpose learning areas and tutorial rooms	320	4.5
Sole-occupancy unit of a Class 3 or 9c building	160	5
Storage	80	1.5
Service area, cleaners room and the like	80	1.5
Toilet, locker room, staff room, rest room and the like	80	3
Wholesale storage area with a vertical illuminance target of 160 lx	160	4
Stairways, including fire-isolated stairways	80	2
Lift cars	160	3

Illumination power density adjustment factors

It is recognised that there are many variables in lighting that limit the ability to achieve the maximum illumination power density. One is the size of the room and so note 3 of [Table J6.2a](#) explains how the illumination power density may be increased for small rooms. A further series of adjustment factors have been included in [Table J6.2b](#) and [Table J6.2c](#) that allow credit for additional energy control devices or to allow the use of high Colour Rendition Lights.

The adjustment factors are applied to the maximum illumination power density in [Table J6.2a](#). This means that if a designer chooses to use a less efficient light source or luminaire, compliance can be achieved by the use of a supplementary control device such as an occupancy sensor or photoelectric device.

Occupancy sensors represent an efficient way of tailoring the lighting to the usage of the space. The fewer lights that are controlled by an individual sensor the greater the energy saved, however, there is less cost saving on the energy to offset the cost of the sensor. Therefore, there is a graduated scale of adjustment factors for the area of lights controlled.

For lecture theatres, auditoria and large spaces of transient usage, the contribution of detectors should be assessed using a Performance Solution rather than the Deemed-to-Satisfy Provisions.

J6.3 Interior artificial lighting and power control**Intent**

To set the minimum requirements for switches and other lighting control devices.

The lighting control requirements are directed at enabling occupants to save energy on lighting and power when the space is not occupied or the service is not needed.

[J6.3\(a\)](#) requires each room or space to be individually switched or controlled. This is to ensure that when lighting to a small area is required, lighting to a larger area is not also activated.

[J6.3\(b\)](#) requires that an occupant activated device be installed in a sole-occupancy unit of a Class 3 building, based on the likelihood that guests may not switch off the power when leaving the room.

This power includes the lighting, air-conditioning, exhaust fans and bathroom heating when the room is not occupied. The control device is not detailed so the requirements can be met by various systems such as a security device like a room

Energy efficiency

key slot at the door, a motion detector, or any device or system that can monitor the occupancy of the unit. For the purpose of applying this provision, occupancy should be taken as the physical presence of people in the room rather than having someone registered or checked into the unit.

J6.3(c) requires lighting to be locally switched from a position that is visible in the room or in an adjacent room. If the controls are in an adjacent room, then the lighting that is controlled must be visible from the switching position. This is to reduce the possibility of lighting being left on in unoccupied areas because it cannot be seen.

Most buildings are required to have local control of the lighting in manageable blocks. This is to avoid the situation where a large area of lighting has to be switched on when only a small area is required, simply because there is no subdivision of the switching area. Buildings with lighting that is likely to be totally on or totally off, such as a theatre or swimming pool, are exempted.

J6.3(d) requires a non-residential building or storey (i.e. other than a sole-occupancy unit in a Class 2 or 3 and Class 4 part) over 250 m² to have controls to prevent most of the lighting being left on 24 hours a day. This can be a time switch or occupancy sensor. The time switching has to comply with [Specification J6](#). Simple manual override switches or bypass switches are not allowed as they give the ability to permanently disable the control. The time switch control does not preclude the need for local control.

J6.3(e) applies to only certain buildings and specifically to switching the lights near windows.

J6.3(f) requires the artificial lighting in fire-isolated stairways, passageways and ramps to be controlled by motion detectors. Note that this does not apply to emergency lighting required in accordance with [Part E4](#).

J6.4 Interior decorative and display lighting

Intent

To set the minimum requirements for controlling decorative and display lighting.

These are additional control requirements for decorative and display lighting as distinct from those for other artificial lighting in a space.

J6.5 Exterior artificial lighting

Intent

To set the minimum requirements for exterior artificial lighting.

It is not practical to apply illumination power density to external lighting in the same way as it has been applied to internal lighting because it is difficult to define the relevant area for all situations. The requirements are therefore aimed at ensuring efficient light sources are used or that the lighting only operates when it is required.

All external lighting must be controlled by either a daylight sensor or time switch.

J6.6 Boiling water and chilled water storage units

Intent

To set the minimum requirements for controlling boiling water and chilled water storage units.

A time switch is required for boiling water and chilled water storage units that continually maintain water at temperature because they can waste energy overnight and during weekends. This clause is not intended to apply to units that heat or chill water as it is being drawn off.

J6.7 Lifts

Intent

To set the minimum energy efficiency requirements for lifts.

The intent of this provision is to ensure lifts that are expected to have high frequency usage are the most efficient.

A lower energy rating has been allowed for dedicated goods lifts, i.e. a lift used for carrying goods or materials and in which only the attendant and the persons required to load and unload are intended (or permitted) to travel. This is in recognition that these lifts have different requirements than passenger lifts.

J6.8 Escalators and moving walkways**Intent**

To set the minimum energy efficiency requirements for escalators and moving walkways.

The intent of the provisions is to ensure that escalators and moving walkways are configured to save energy when not in use.

Part J7 Heated water supply and swimming pool and spa pool plant

Deemed-to-Satisfy Provisions

J7.0 Deemed-to-Satisfy Provisions

Intent

To clarify that [JP1](#) will be satisfied if compliance is achieved with [Parts J1](#) to [J8](#).

See comments for Deemed-to-Satisfy Provisions of [J0.0](#).

J7.1 * * * * *

The content of [J7.1](#), which existed in BCA 2005, has been removed. The provision number [J7.1](#) has been retained without text so as not to change the numbering of the current BCA from that of BCA 2005.

J7.2 Heated Water Supply

Intent

To set the minimum requirements for heated water systems.

The measures for heated water supply, which existed in BCA 2013, are now contained in [Part B2](#) of NCC Volume Three — Plumbing Code of Australia.

J7.3 Swimming pool heating and pumping

Intent

To set the minimum requirements for swimming pool heating and pump control.

This provision states what energy source may be used to heat a swimming pool, and how efficient it must be if it is a gas heater. It is to meet the objective of reducing greenhouse gas emissions. It also requires a swimming pool to have—

- if heated by gas or heat pump—
 - a cover with a minimum R-Value of 0.05; and
 - time switch operation for the heater; and
- a time switch to control the operation of a circulation pump.

Some jurisdictions may have Performance Requirements for a pool cover under the Smart Approved Water Mark Scheme. [J7.4](#) has specific requirements for spa heating and pumping. Therefore, for the purpose of this provision, a swimming pool does not include a spa.

J7.4 Spa pool heating and pumping

Intent

To set the minimum requirements for spa pool heater efficiency and pump control.

As for swimming pools, this provision states what energy source may be used to heat a spa. It also requires a spa which is heated by gas or a heat pump to have—

- a cover with a minimum R-Value of 0.05; and
- a push button and time switch operation for the heater.

680 L is generally accepted as the capacity of when a spa bath becomes a spa pool.

Part J8 Facilities for energy monitoring

Deemed-to-Satisfy Provisions

J8.0 Deemed-to-Satisfy Provisions

Intent

To clarify that [JP1](#) will be satisfied if compliance is achieved with [Parts J1](#) to [J8](#).

See comments for Deemed-to-Satisfy Provisions of [J0.0](#) as appropriate.

The emphasis for [Part J8](#) is on being able to maintain the required level of performance. To achieve this, consideration needs to be given to ensuring that there are adequate provisions made in the design for monitoring facilities so that excessive energy use can be detected and rectified .

J8.1 Application of Part

Intent

To clarify that the Deemed-to-Satisfy Provisions of [Part J8](#) do not apply to a sole-occupancy unit of a Class 2 building, a Class 4 part of a building or a Class 8 electricity network substation.

[Part J8.0](#) does not apply to private dwellings, i.e. Class 1 buildings, therefore it is also not applied to the sole-occupancy units of Class 2 buildings, or Class 4 parts of buildings.

The access for maintenance and power monitoring procedures for Class 8 electricity network substations have inherent and critical characteristics that either supercede or vary from the procedures adopted and applied to other buildings. Therefore, [Part J8](#) does not apply.

J8.2 * * * * *

The content of [J8.2](#), which existed in BCA 2014, has been removed. The number [J8.2](#) has been retained without text so as not to change the numbering of the current BCA from that of BCA 2014.

J8.3 Facilities for energy monitoring

Intent

To ensure that the building has the facilities to monitor its energy usage.

In order for maintenance personnel to ensure that active energy efficiency items and systems continue to operate at their required level of performance, they need to know the energy usage of the building over time and also the usage of individual services in a large building. To facilitate this outcome, the data collected by energy meters is to be made readily accessible to personnel without requiring the physical inspection of meters. The data must be transmitted to a communications platform (e.g. a computer) in a format (e.g. a .csv file) that allows for its analysis by maintenance personnel.

Specification J1.2**Material properties****Deemed-to-Satisfy Provisions****1 Scope****Intent**

To make sure that [Specification J1.2](#) covers the relevant properties attributed to common construction materials, air films and airspaces, and reflective surfaces.

2 Construction Deemed-to-Satisfy**Intent**

To detail the relevant properties attributed to common construction materials, air films and airspaces, and reflective surfaces.

The values provided in [Table 2a](#) are material density values and thermal conductivity (k) values for materials. [Tables 2b](#) and [2c](#) list the R-Values of airspaces and films and expected added R-Values provided by a reflective surface. All except the material density can be used in determining the Total R-Value of a roof, wall or floor system.

The term surface density suggests mass per unit volume but in this context is the mass of the full thickness of 1 square metre of wall surface area.

[Clause 2\(d\)](#) explains the meaning of a ventilated roof space.

Specification J1.5a

Calculation of U-Value and solar admittance

Deemed-to-Satisfy Provisions

1 Scope

Intent

This Specification describes the two calculation methods for determining if wall-glazing construction complies with the U-Value and solar admittance requirements in [J1.5](#).

Wall-glazing calculations

Two Deemed-to-Satisfy compliance pathways for both Total System U-Value and solar admittance are detailed in [Specification J1.5a](#):

- Method 1: Each aspect of wall-glazing construction is required to meet the applicable Total System U-Value and solar admittance for the building classification and climate zone.
- Method 2: The wall-glazing construction facing multiple aspects are assessed together to determine if it collectively achieves the applicable Total System U-Value and solar admittance. Method 2 effectively allows for trading of thermal performance values between different aspects and is intended to make it easier for a building to have the same glazing system in all directions.

Glazing

In applying these methods, the Total System U-Value and Total System SHGC of glazing must account for the combined effect of the glass and frame. The measurement of these Total System U-Values and Total System SHGCs is specified in the Technical Protocols and Procedures Manual for Energy Rating of Fenestration Products of the Australian Fenestration Rating Council (AFRC).

Various assessors using AFRC procedures might refer to their published performance values by slightly different terms (including “U-factor” or “Uw” for Total System U-Value or “SHGC” for Total System SHGC). Such values can be used under [Specification J1.5a](#) provided they measure combined glass and frame performance according to AFRC requirements.

Shading

The presence of shading projections and devices will reduce the level of thermal performance that is required of glazing, as detailed in the calculation methods for solar admittance. However, to be effective, shading projections and devices must restrict a significant proportion of solar radiation.

External shading devices, such as shutters, blinds, vertical or horizontal building screens are required to be capable of restricting the amount of summer solar radiation that reaches the glazing by at least 80%. This is the sum of the amount of hour-by-hour summer (December, January, February) solar radiation that does not reach the glazing as a percentage of what would have reached the glazing if the shading device was not fitted.

The amount of summer solar radiation that reaches the window may be measured cumulatively over the three month period of December to February if a fixed device is used, alternatively if the device adjusts automatically in response to the sun, the worst case scenario during the period of December to February can be used.

The 80% figure acknowledges that while a device may be capable of providing 100% shade during summer, some leakage of solar radiation may occur at the sides of the device. For example, although adjustable blinds are capable of providing 100% shade when they are fully closed or lowered, it is accepted that they may allow some summer solar radiation to reach the glazing at the sides of the blinds. Similarly, while a horizontal building screen may have slats which have been designed to provide 100% shade in summer, it is accepted that there may be some leakage of solar radiation at the sides of the slats.

A degree of judgement is required to determine whether the amount of summer solar radiation that reaches the glazing at the sides of a device exceeds that permitted. Generally, a close fitting blind should sufficiently restrict the amount of summer solar radiation that reaches the glazing at the sides of the device. A horizontal building screen that extends either side of the glazing by the same projection distance (P) should also restrict a sufficient amount of solar radiation at the sides of the slats.

Adjustable shading devices can only be recognised in the calculations if they are automatically operated. This is based on the premise that occupants are less likely to operate the devices as those in the best position to operate the devices are less inclined to do so because they are not paying the energy bills.

For complying with the shading requirement, note that the shading projection for walls is measured from the wall

Energy efficiency

face whereas for glazing the projection is measured from the glass face.

Gutters can only be considered as providing shading if attached to a building projection such as a veranda, fixed canopy, eaves, shading hood, balcony or the like. On their own they are likely to be well above the head of the window and so not likely to produce any significant shading.

Wall construction

The figure below provides examples of typical insulation locations in various types of wall construction. The Total R-Value required is achieved by adding the material R-Value of the basic wall and the material R-Value of any additional insulation incorporated. The Total R-Value of the typical wall construction has been produced by adding together the material R-Values for outdoor air film, wall cladding, wall airspace, internal lining and internal air film.

Note it should not be assumed that these figures are representative of all construction scenarios. For example the spacing of framing members, the number of windows or the specific type of frame could all effect the actual Total R-Value by creating thermal bridging between elements or by compressing insulation. If following a Deemed-to-Satisfy compliance pathway, Total R-Value must be calculated using the methods prescribed in AS/NZS 4859.2 to properly account for these effects.

The most common forms of construction for low-rise buildings are represented. It has not been possible to cover other forms of construction, particularly those used for high-rise construction, because of the wide range and the greater influence of winds, cyclones and earthquakes on the elements of the building. The Total R-Value of other forms of construction can be determined by adding the individual R-Values together.

For a material that is not listed as an item below, other than air, the R-Value may be determined by dividing the thickness of the item in metres by the thermal conductivity in W/m.K (typical values are described in [Specification J1.5a](#)).

Reflective insulation that has just one reflective surface is considered to achieve the R-Values when used in conjunction with the Total R-Value of the common wall construction stated in the figure below. The actual R-Value added by reflective insulation should be determined for each product in accordance with the standards prescribed in the BCA, which take into consideration factors such as the number of adjacent airspaces, dimensions of the adjacent airspace, whether the space is ventilated and the presence of an anti-glare coating.

The width for any reflective airspaces adjacent to reflective insulation will not override other requirements such as minimum cavity requirements for masonry waterproofing.

Where a diagram shows reflective insulation or other insulation, these are indicative only. In some climates and using certain materials, neither may be necessary. In other cases, reflective insulation or other insulation may be provided separately or in combination to give the required R-Value.

A minimum thickness of 70 mm is stated for framing. In some cases, the frame thickness may need to be increased to avoid compressing the bulk insulation and thus reducing its R-Value.

External wall construction description	Item	Item description	R-Value
(a) Masonry veneer - 25 mm to 50 mm cavity, 10 mm internal plaster on 90 mm stud frame	1.	Outdoor air film (7 m/s)	0.04
	2.	Masonry (See Notes 3 and 4)	0.09
	3.	Cavity and airspace (115 to 140 mm, made up of 90 mm stud + 25 mm to 50 mm airspace non-reflective and unventilated)	0.17
	4.	Plasterboard, gypsum (10 mm, 880 kg/m ³)	0.06
	5.	Indoor air film (still air)	0.12
			Total R-Value: 0.48

Energy efficiency

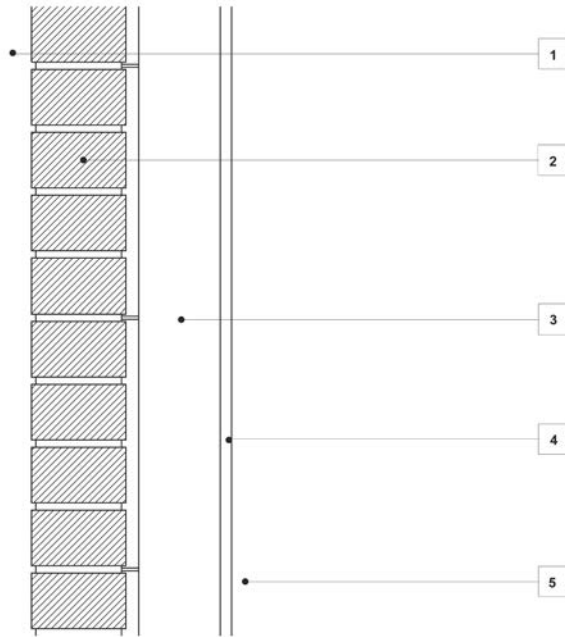

External wall construction description	Item	Item description	R-Value
(b) Cavity masonry - 20 mm to 50 mm cavity, 10 mm internal plaster on battens or furring channels	1.	Outdoor air film (7 m/s)	0.04
	2.	Masonry (See Notes 3 and 4)	0.09
	3.	Masonry cavity (20 mm to 50 mm, non-reflective and unventilated)	0.17
	4.	Masonry (See Note 4)	0.09
	5.	Airspace (20 mm to 35 mm, non-reflective and unventilated)	0.17
	6.	Plasterboard, gypsum (10 mm, 880 kg/m ³)	0.06
	7.	Indoor air film (still air)	0.12
Total R-Value: 0.74			

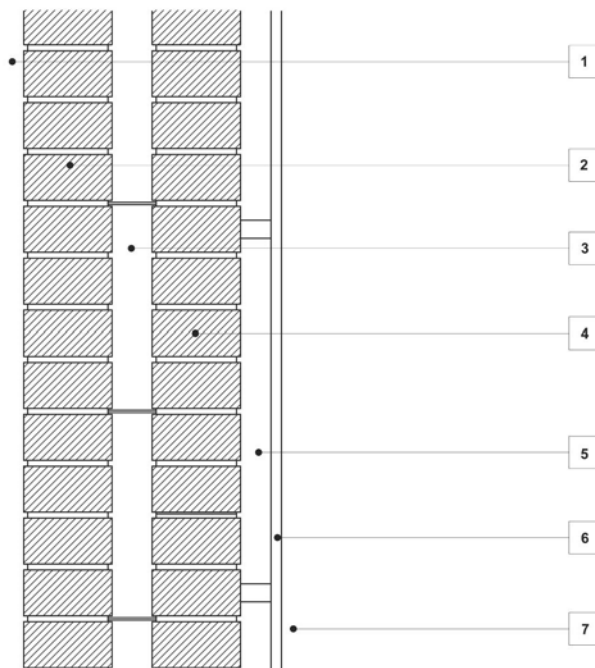

Energy efficiency

External wall construction description	Item	Item description	R-Value
(c) Dense weight hollow concrete block with internal plaster on battens or furring channels	1.	Outdoor air film (7 m/s)	0.04
	2.	Dense weight hollow concrete block (See Notes 3 and 4)	0.15
	3.	Airspace (20 mm to 40 mm non-reflective and unventilated)	0.17
	4.	Plasterboard, gypsum (10 mm, 880 kg/m ³)	0.06
	5.	Indoor air film (still air)	0.12
			Total R-Value: 0.54

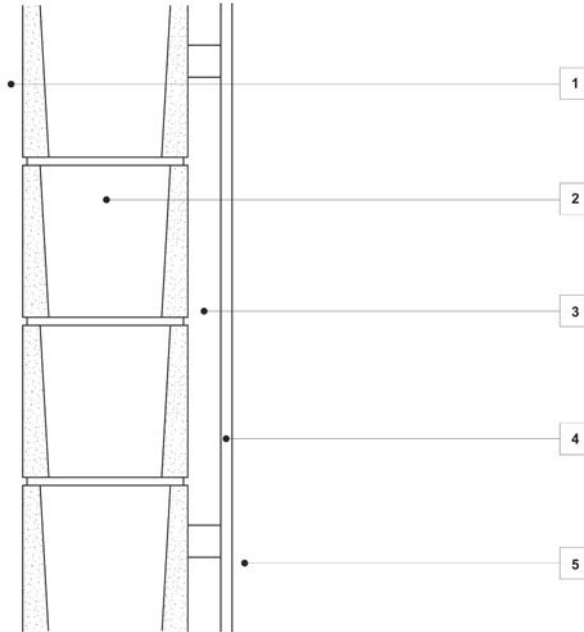

External wall construction description	Item	Item description	R-Value
(d) 125 mm solid reinforced concrete (dense weight) - 10 mm internal plaster on battens or furring channels	1.	Outdoor air film (7 m/s)	0.04
	2.	125 mm minimum solid reinforced concrete (See Note 3)	0.09
	3.	Airspace (20 mm to 40 mm non-reflective and unventilated)	0.17
	4.	Plasterboard, gypsum (10 mm, 880 kg/m ³)	0.06
	5.	Indoor air film (still air)	0.12
			Total R-Value: 0.48

Energy efficiency

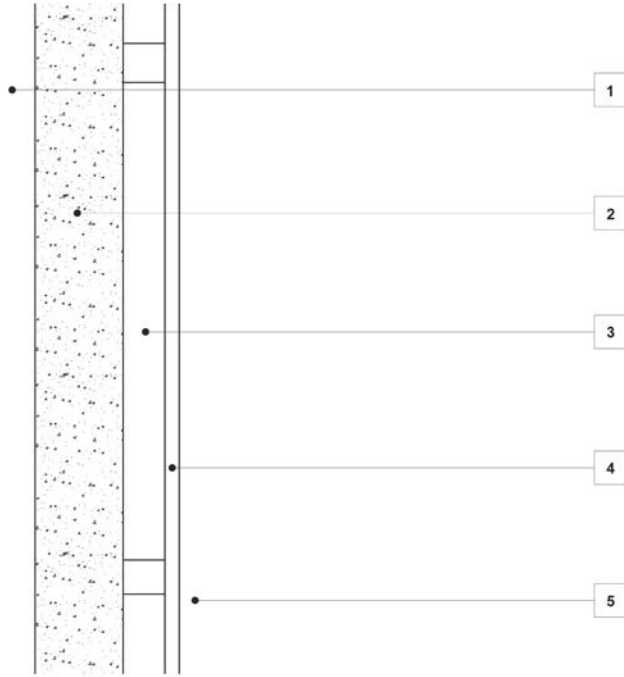

External wall construction description	Item	Item description	R-Value
(e) Timber wall - external 6 mm cement sheet cladding, 90 mm stud frame, 10 mm plaster	1.	Outdoor air film (7 m/s)	0.04
	2.	Fibre-cement (6 mm, 1360 kg/m ³)	0.03
	3.	Airspace (90 mm non-reflective and unventilated)	0.17
	4.	Plasterboard, gypsum (10 mm, 880 kg/m ³)	0.06
	5.	Indoor air film (still air)	0.12
			Total R-Value: 0.42

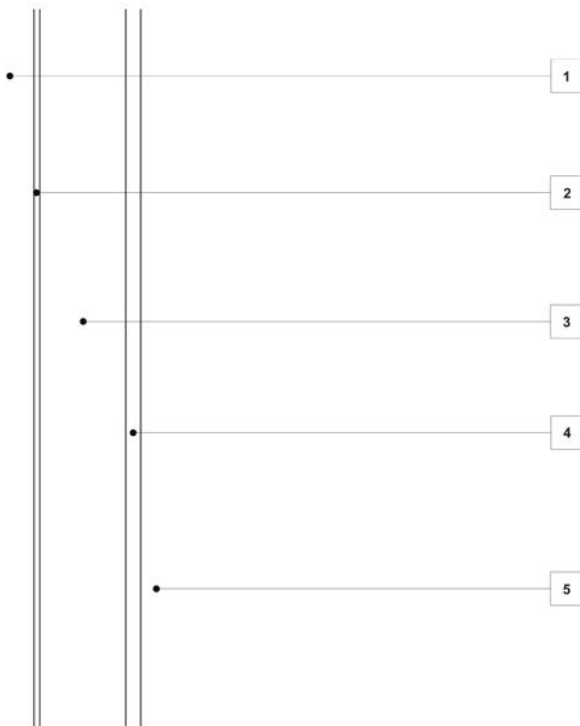

Energy efficiency

External wall construction description	Item	Item description	R-Value
(f) 200 mm autoclaved aerated concrete block - 10 mm internal plaster on battens or furring channels	1.	Outdoor air film (7 m/s)	0.04
	2.	Autoclaved aerated concrete block (200 mm, 350 kg/m ³)	2.00
	3.	Airspace (20 mm to 40 mm non-reflective and unventilated)	0.17
	4.	Plasterboard, gypsum (10 mm, 880 kg/m ³)	0.06
	5.	Indoor air film (still air)	0.12
			Total R-Value: 2.39

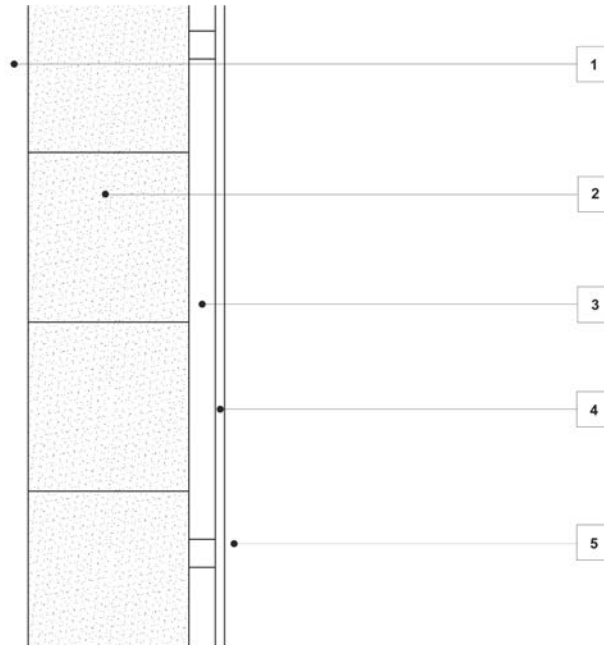

External wall construction description	Item	Item description	R-Value
(g) 150 mm hollow-core concrete panels - 10 mm internal plaster on battens or furring channels	1.	Outdoor air film (7 m/s)	0.04
	2.	Prestressed hollow-core concrete panels (150 mm, 1680 kg/m ³ , 30% cores)	0.14
	3.	Airspace (20 mm to 40 mm non-reflective and unventilated)	0.17
	4.	Plasterboard, gypsum (10 mm, 880 kg/m ³)	0.06
	5.	Indoor air film (still air)	0.12
			Total R-Value: 0.53

Energy efficiency

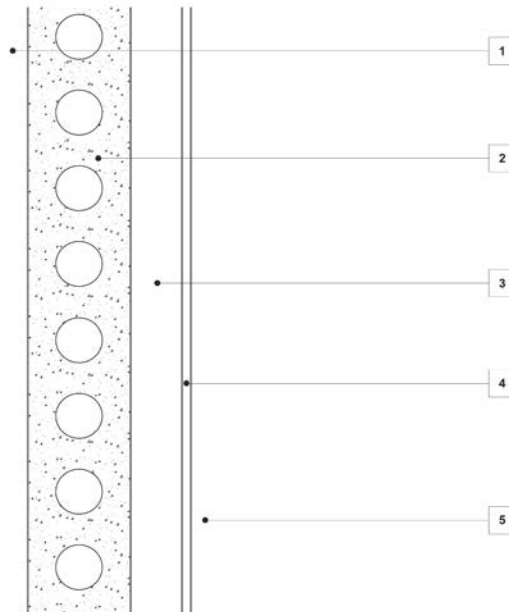

External wall construction description	Item	Item description	R-Value
(h) Dense weight hollow concrete block with external 6 mm cement sheet cladding on battens or furring channels	1.	Outdoor air film (7 m/s)	0.04
	2.	Fibre-cement (6 mm, 1360 kg/m ³)	0.03
	3.	Airspace (20 mm to 40 mm non-reflective and unventilated)	0.17
	4.	Dense weight hollow concrete block (See Note 4)	0.15
	5.	10 mm render	0.02
	6.	Indoor air film (still air)	0.12
Total R-Value: 0.53			

Energy efficiency

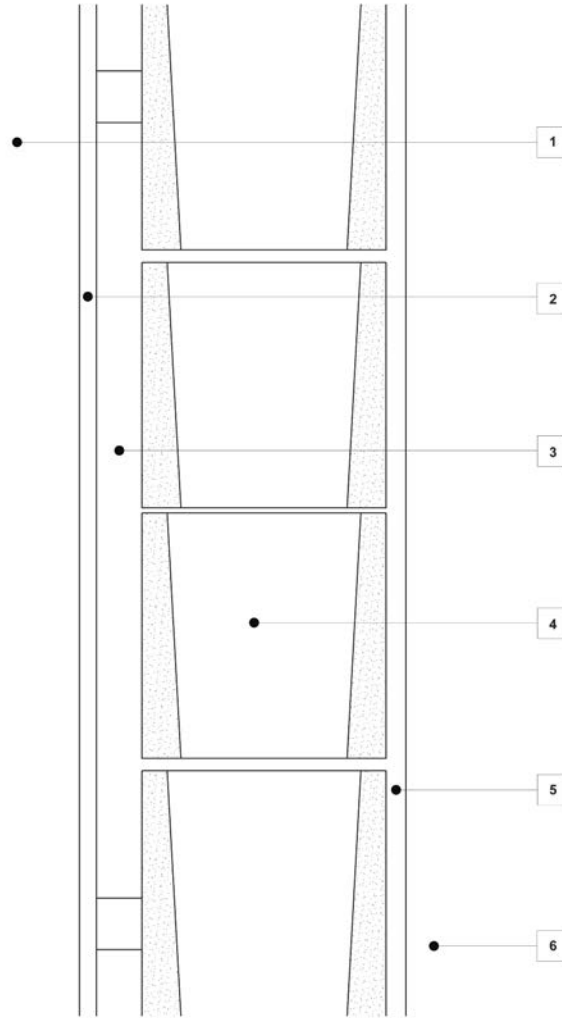

External wall construction description	Item	Item description	R-Value
(i) Dense weight hollow concrete block with external 6 mm cement sheet cladding on battens or furring channels	1.	Outdoor air film (7 m/s)	0.04
	2.	Clear or opaque glass (10 mm, 25600 kg/m ³)	0.01
	3.	Airspace (20 mm to 40 mm non-reflective and unventilated)	0.17
	4.	Steel sheet (1 mm to 3 mm, 7850 kg/m ³)	0.00
	5.	Airspace (2 mm to 100 mm non-reflective and unventilated)	0.17
	6.	Plasterboard, gypsum (10 mm, 880 kg/m ³)	0.06
	7.	Indoor air film (still air)	0.12
			Total R-Value: 0.57

Energy efficiency

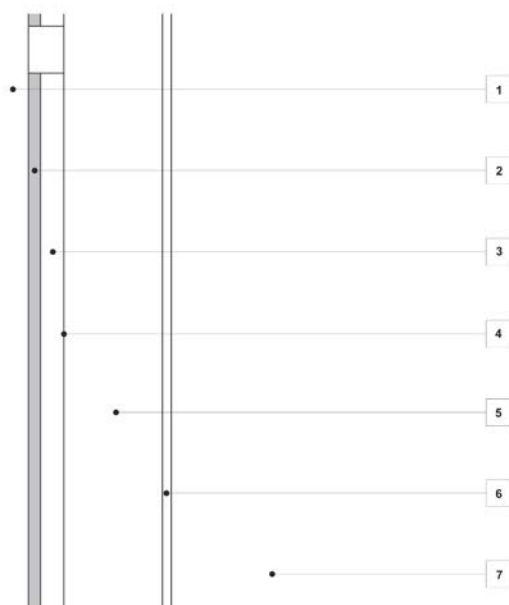

Notes:

1. The R-Value of an item, other than an airspace, air film or air cavity, may be increased in proportion to the increased thickness of the item.
2. The Total R-Value of a form of construction may be increased by the amount that an individual item is increased.
3. The addition of 10 mm of render to a concrete or masonry wall will increase the Total R-Value by 0.02.
- (a) The typical R-Value in Figure 2(a) and (b) is for 90 mm dense weight concrete block.
- (b) The typical R-Value in Figure 2(c) and (h) is for 140 mm dense weight hollow concrete block.
- (c) The typical R-Value in Figure 2(d) is for 125 mm solid reinforced concrete (2400 kg/m³).
- (d) Other typical R-Values for masonry and concrete are as follows and may be substituted for those above:

90 mm clay brick:

(density 1430 kg/m ³)	0.16
(density 1690 kg/m ³)	0.14
(density 1950 kg/m ³)	0.12

110 mm clay brick:

(density 1430 kg/m ³ , 2.75 kg/brick)	0.20
(density 1690 kg/m ³ , 3.25 kg/brick)	0.17
(density 1950 kg/m ³ , 3.75 kg/brick)	0.14

Dense weight hollow concrete block:

110 mm	0.12
190 mm	0.20

4. The Total R-Values in this Figure are for external walls. The Total R-Value for an internal wall of the same construction would be 0.08 greater because the R-Value for an outdoor air film would be replaced by that of an indoor air film.
5. Where a cavity or airspace is filled, the R-Value listed for the cavity must be deducted from the Total R-Value of the wall.

Specification J1.5b**Spandrel panel thermal performance****Deemed-to-Satisfy Provisions****1 Scope****Intent**

To detail how to calculate the thermal performance of spandrel panels.

2 Spandrel panel R-Value – Calculation Method 1**Intent**

To detail the R-Values considered to be achieved by common forms of spandrel panels.

3 Spandrel panel R-Value – Calculation Method 2**Intent**

To detail how to calculate the Total System R-Value of spandrel panels.

This method has been provided to enable the calculation of the Total System R-Value of less common forms of spandrel panels not covered in [Clause 2](#).

Specification J1.6**Sub-floor thermal performance****Deemed-to-Satisfy Provisions****1 Scope****Intent**

To detail the thermal performance achieved by sub-floor spaces and soil in direct contact with a floor.

2 Sub-floor thermal performance**Intent**

To provide the R-Values considered to be achieved by sub-floor spaces and soil in direct contact with a floor.

The R-Values provided are intended to assist in determining whether and how much additional insulation is required to achieve the minimum Total R-Values in [Table J1.6](#). This is provided as an alternative to carrying out a more detailed calculation using Section 3.5 of CIBSE Guide A.

Specification J6

Lighting and power control devices

Deemed-to-Satisfy Provisions

1 Scope**Intent**

To clarify the extent of items covered by this Specification.

2 Lighting timer**Intent**

To detail the required performance of corridor light timers.

Lighting timers are time delay switches that activate a section of lighting when the button is pressed, and switches the lights off again after a predetermined time, provided the button is not pushed again. The provisions for the minimum distance of travel into the space, and for the 5% of lighting that must remain on in larger areas, are designed to reduce the situation of walking into a dark space to switch on the lighting. In many applications the exit signs will provide the continuous 5% of lighting required.

3 Time switch**Intent**

To detail the required performance of time switches.

Time switches are devices that turn lights or equipment on and off at predetermined and pre-programmed times.

4 Motion detectors**Intent**

To detail the required performance of motion detectors.

The motion detector requirements are similar to those of the corridor lighting timer, except that a motion detector is activated by the motion of people, and the operation of the lighting is maintained while the motion continues.

The advantages of motion detectors are:

- a person does not need to find the button; and
- a person can enter the space with more confidence as another person already within the space would have activated the lighting; and
- the time duration for the lighting to be activated does not need to be as long as it does with a corridor lighting timer because the lighting is continuously reset, whereas with a timer, the duration has to be set for the slowest person travelling the greatest distance.

The clause specifies different requirements for motion detectors for four situations—

- a Class 2, 3 or Class 9c building other than sole-occupancy units; and
- a Class 5, 6, 7, 8, 9a and 9b building; and
- outside a building, including when controlling a light in a carpark entry zone; and
- when in a fire-isolated stairway.

Fire-isolated stairway lights

Unlike other lights required to be controlled by a motion sensor, in a fire-isolated stairway it is acceptable for lights to be dimmed to at least 30% of their peak power instead of being switched off.

Definitions

Schedule 3 Definitions

Schedule 3 Definitions

Schedule 3 **Definitions**

Definitions

Schedule 3

Definitions

Definitions

Intent

To define the precise meaning of key words and expressions for the purposes of Volume One of the NCC.

Where a definition in the NCC has been considered to be self-explanatory, it has not been included in this guide.

Accessible

Used in provisions regarding access for people with a disability. See [Part D3](#), [E3.6](#), [F2.4](#) and [H2](#).

Accessway

A path of travel suitable for use by people with a disability. It is an abbreviation from AS 1428.1 which defines the term continuous accessible path of travel (accessway) as an uninterrupted path of travel providing access to all accessible facilities.

Accredited Testing Laboratory

An Accredited Testing Laboratory is an organisation authorised to give an opinion on the use of a material, product, construction or design.

Testing authorities are accredited by the National Association of Testing Authorities (NATA). NATA publishes a directory explaining which authorities are accredited to carry out what tests. International organisations are also recognised by NATA; a directory also details these organisations.

Paragraph (c) of the definition prescribes that valid test reports from organisations which were recognized as being Accredited Testing Laboratories under legislation at the time the test was undertaken may still be accepted.

Activity support level

This term is used to articulate whether the height of the habitable room or space is sufficient and by what degree. This is achieved by having regard to the room or space's intended use by occupants, through consideration of the defined terms 'activity traits' and 'occupant traits'.

Activity traits

This term is used to describe the characteristics of the activities that will be undertaken in a habitable room or space.

For example, the activities likely to be undertaken in a bedroom, and the associated features are—

- sleeping - a person laying horizontally,
- resting - a person laying horizontally or sitting upright on the bed,
- leisure activities, such as reading a book - a person sitting upright on the bed, with enough space to stretch their arms vertically,
- dressing/changing clothes - a person standing with enough space to stretch their arms vertically.

Aged care building

The definition describes a residential building for the accommodation of the aged. These buildings are the homes of the residents. To be an aged care building the residents must be provided with personal care services and 24 hour assistance to evacuate. The definition applies to Class 9c buildings. If a building does not satisfy the definition, then for NCC purposes it is not an aged care building and cannot be constructed as one. Such a building would potentially be an ordinary Class 3 or 9a building and would need to comply with the relevant provisions.

The NCC contains a number of specific provisions for Class 9c buildings.

Air-conditioning

This definition relates to the context in which it is used and does not necessarily cover special cases such as when air is only humidified, filtered or otherwise treated. The intent is to cover a system, including its components, that provides a controlled internal environment in a building where the primary purpose for controlling the environment is maintaining occupant comfort. It should be noted that the occupants may not always be comfortable, but the conditions are sufficiently tolerable for occupants to minimise their use of services for heating and cooling. It does not cover a system that primarily and directly serves equipment such as that used for cold rooms or hot rooms, where the temperature is above or below normal comfort levels. Examples would include such rooms in a butcher's shop, laboratories, fruit storage rooms, or the like.

The definition also does not apply to a system that is provided to maintain conditions for the effective operation of equipment or processes, such as equipment used in a Class 8 electricity network substation or an air-conditioning system specifically

designed to serve computers in a data centre. These exemptions recognise that these installations have specific air quality, heat load and temperature limits critical to the operation of sensitive equipment and processes.

The term is used in the Deemed-to-Satisfy Provisions through the defined term “conditioned space” to require energy efficiency features including envelope treatment.

Although the definition is termed air-conditioning, the conditioning may be achieved without treating the air forced into and through the space. The air in the space may be conditioned by hot or cool surfaces. This includes residential heating systems, such as gas and combustion appliances, that are not always considered to be air-conditioning in the traditional sense. The conditioning may also be achieved by evaporative coolers.

Alpine area

Areas generally subject to snow, or places where snow can add a significant load to buildings, or cause difficulties with egress.

Ancillary element

An ancillary element is a building component, material or article that is not integral to the construction of another building element. Its function is secondary in nature and should not form part of the building element or feature to which it is supplementing. An ancillary element does not add significantly to the building’s fire load or is unlikely to significantly contribute to the spread of fire because of its size, construction, location and so on.

Annual greenhouse gas emissions

This is the theoretical amount of greenhouse gas emissions attributable to the energy calculated to be consumed under certain specific conditions in consideration of operating profiles, internal loads and plant efficiencies. It is used in [Verification Method JV3](#) that compares the calculated greenhouse gas emissions attributable to the energy consumption with that of a complying reference building. It should not be considered a prediction of the actual greenhouse gas emissions attributable to the energy consumption of an actual building as there could be major differences in the conditions such as the internal loads of the building and the hours of operation. It differs from annual energy load because it is affected by the type of heating or cooling appliance used, for example, heating by a reverse cycle air-conditioner uses less than half the energy that a gas fired heater would use to meet the same annual energy load.

Calculating GHG emissions:

[Verification Method JV3](#) references the National Greenhouse Account Factors as the conversion factors for each State and Territory that are to be used when converting a unit of energy (gas or electricity), into a greenhouse gas equivalent amount. NCC 2019 has the 2018 figures listed, but it should be noted that these figures are updated and published on the Department of the Environment and Energy’s website in July each year.

Appropriately qualified person

An appropriately qualified person is a person recognised by an authority having jurisdiction as qualified to provide evidence under [Part A5](#) that a material, product, form of construction or design complies with a Performance Requirement or Deemed-to-Satisfy Provision. The person does not necessarily need to be licenced or registered unless required by the State or Territory regulatory system.

Assembly building

Describes buildings classifiable as Class 9b buildings.

Assessment Method

See [Part A2](#).

Atrium and atrium well

An atrium can pose unique fire and smoke hazards. As such, the NCC lists Deemed-to-Satisfy Provisions for their construction.

An atrium is created by the connection of 2 or more storeys by an opening in the floor. It also includes the space not fire-separated from the rest of the building. The atrium well is that part extending through the openings in the floors. See [Figure Schedule 3 \(AT\)](#).

Figure Schedule 3(AT) Section through an atrium

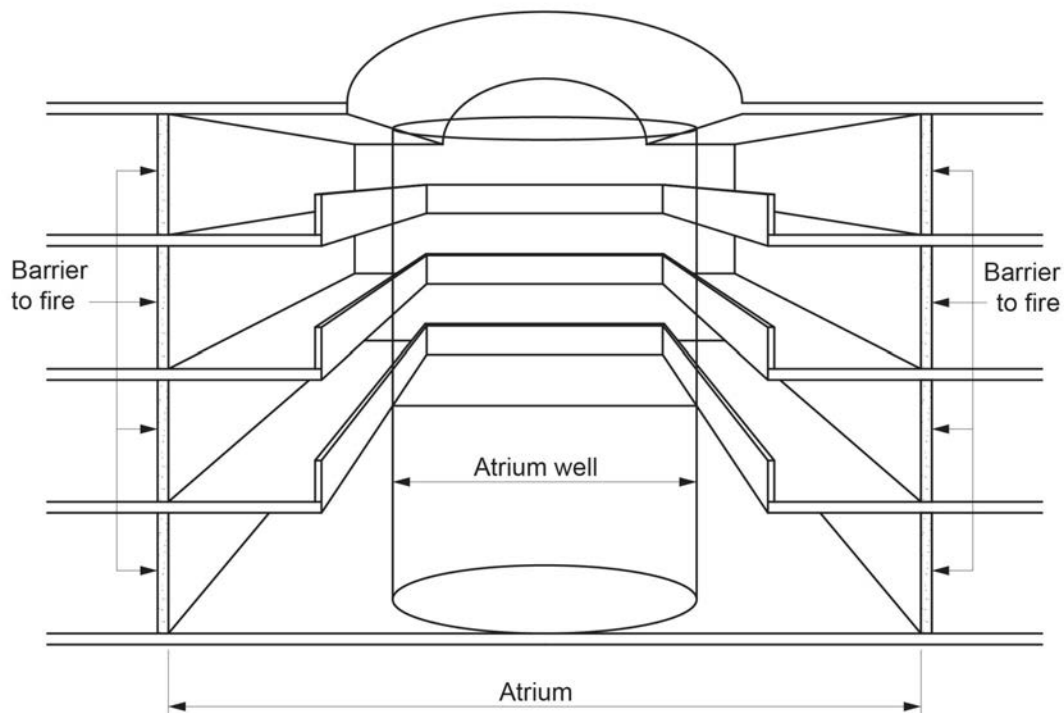

Average recurrence interval

Refers to a set number of years when a rainstorm of a 5 minute rainfall duration intensity can statistically be expected to occur. If a 10-year period is set, the expected rainstorm would be less intense than if a 50-year period is set. Statistically, a heavier storm is more likely to occur every 50 years than every 10 years.

This term is used in the design of stormwater drainage systems. See [FP1.1](#) and [FP1.2](#). Also refer to AS/NZS 3500, or *Australian Rainfall and Run-off*, published by the Institution of Engineers (Australia).

Average specific extinction area

A test in accordance with AS/NZS 3837 determines the average specific extinction area of a material. A lower value indicates better performance.

Backstage

There are special provisions for backstage areas because of the high fire load posed by scenery and props.

Carpark

A carpark can be a whole, or part, of a building. It is any building not associated with a Class 1 building and contains more than three vehicle spaces on one storey. It is not a “private garage”.

Example

A building could be a carpark if:

- it is either a stand-alone Class 7a building, or it is appurtenant to any other building (excluding a Class 1 building); or
- it is intended to park four-or-more trucks or other vehicles and it is not used for ancillary purposes other than a carpark.

Cavity wall

Used only in Verification Method [FV1](#) and defines wall construction which includes a drained cavity. The required cavity can consist of clear unobstructed space or cavity battens. However, where cavity battens are used the “compliance” component of the Verification Method must be considered to ensure water does not pool on battens or other cavity surfaces.

The Verification Method does not restrict the use of horizontal battens, provided the battens have the ability to facilitate the removal of water which may enter the cavity.

The intention of the Verification Method is to provide a means of verifying compliance with [FP1.4](#) for new and innovative products. Therefore, prescriptive requirements such as what constitutes a vented cavity or required cavity depth has not

been provided.

Examples

A direct fix cladding fixed to a cavity batten which is fixed to the building's frame can be considered as a cavity wall for the purposes of [FV1](#).

A perforated horizontal batten may facilitate the drainage of water from the cavity.

A cavity wall is illustrated in [Figure Schedule 3\(CW\)](#).

Figure Schedule 3(CW) Example of a cavity wall

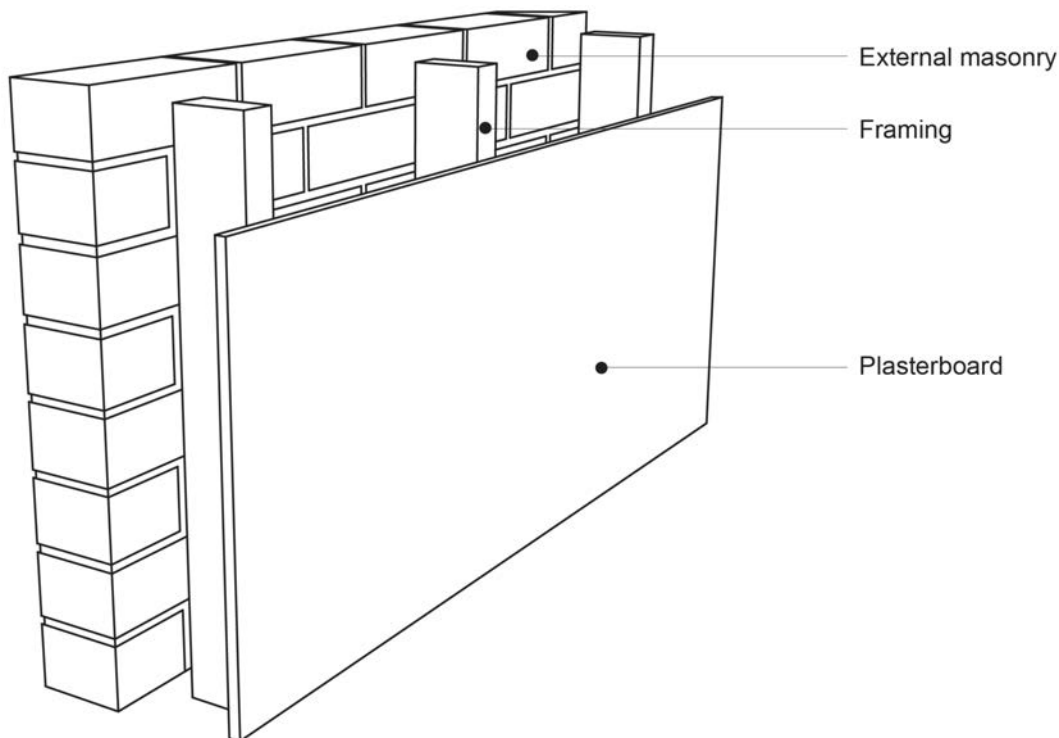

Certificate of Accreditation

A Certificate of Accreditation is issued by a State or Territory accreditation authority and is evidence that a building material, method of construction or design (subject to any specified conditions or limitations) is accepted within that State or Territory as complying with the NCC.

Certificate of Conformity

A Certificate of Conformity issued under the ABCB's voluntary CodeMark Australia scheme is one form of evidence that a building material, method of construction or design (subject to any specified conditions or limitations) complies with the NCC. A Certificate of Conformity issued under the previous CodeMark scheme can still be used as supporting evidence while the certificate remains valid.

Certification body

A certification body is a person or organisation authorised to give an opinion on the use of a material, product, form of construction or design.

Certification bodies, commonly referred to as Conformity Assessment Bodies (CABs), are accredited by the Joint Accreditation System of Australia and New Zealand (JAS-ANZ).

CABs issue certificates under an industry-operated scheme. This differs to the CodeMark Australia or CodeMark Certification Schemes.

Climate zone

Energy efficiency measures vary from location to location depending upon the local climate. For simplicity, locations with approximately similar climates have been combined into eight climate zones and they are shown in both map format and tabular format for major cities. Where greater clarity is needed, an enlargeable version of the map on the ABCB web page shows how the climate zone boundary aligns, in most cases, with a local government boundary.

These climate zones were based on a list of six zones that were developed by the Bureau of Meteorology (BOM), with the addition of a third temperate zone and the inclusion of the existing NCC Alpine areas. The basis of each climate zone is shown in the following table:

Climate zones

Climate zones	Description	Average 3 pm January water vapour pressure (kPa)	Average January maximum temperature (°C)	Average July mean temperature (°C)	Average annual heating degree days
1	High humidity summer, warm winter	≥ 2.1kPa	≥ 30°C	N/A	N/A
2	Warm humid summer, mild winter	≥ 2.1kPa	≥ 30°C	N/A	N/A
3	Hot dry summer, warm winter	< 2.1kPa	< 30°C	≥ 14 °C	N/A
4	Hot dry summer, cool winter	< 2.1kPa	≥ 30°C	< 14 °C	N/A
5	Warm temperate	< 2.1kPa	< 30°C	N/A	≤ 1,000
6	Mild temperate	< 2.1kPa	< 30°C	N/A	1,000 to 1,999
7	Cool temperate	< 2.1kPa	< 30°C	N/A	≥ 2,000 other than alpine areas

Note: For climate zone 8, alpine areas are determined as per NCC Volume One definitions.

Where appropriate, the map was then adjusted for ease of administration, by aligning the climate zone boundaries with local government areas where local knowledge identified the impact of topographical features such as an escarpment or significant micro-climate variation, and where the type of construction required in another zone was felt to be more appropriate for a particular location. There were some further minor adjustments made to the zones following thermal modelling tests of a typical building around the country.

The zones are considered sufficiently accurate for Deemed-to-Satisfy Provisions. More extensive climate data is available when using energy analysis software.

Combustible

A test done in accordance with AS 1530.1 will determine if a material is combustible. If materials used in an assembly contain combustible components, then the assembly is combustible. See also [C1.9](#).

Common wall

A common wall can be on one allotment or straddle a boundary. However, it must be common to adjoining buildings. Some jurisdictions consider a “party wall” a common wall. See your building regulatory body. Where the expressions “internal wall” and “external wall” are used, they are specifically defined to exclude a “common wall”.

Conditioned space

The definition of a conditioned space is included to limit the application of the provisions where a commercial or industrial building has only a small amount of air-conditioning or where a non-habitable room has only a small local heater, such as in a bathroom.

It also clarifies that a conditioned space is one likely to be air-conditioned rather than one that is air-conditioned. For example, one would expect offices and shops to be fully air-conditioned at some time during their life for reasons of productivity, customer comfort or for the protection of products, even though they may not be air-conditioned initially. In some cases, chilled and heated water may be reticulated through duct risers as part of the building design to enable conditioning to be provided as part of a later fit-out.

A conditioned space may include a ceiling or underfloor space that is open to the conditioned space such as a space separated by only a perforated or grille ceiling or floor where the space is a supply air or return air plenum.

While, for the sake of the Deemed-to-Satisfy Provisions, it may be assumed that all Class 3 and Class 5 buildings and most Class 6 buildings will be fully air-conditioned at some time during their life, this may not be the case with all Class 6 buildings and some Class 7, 8 and 9b buildings that do not have a conditioned space or are only partially conditioned. Buildings that typically are not conditioned could be a carpark, market, large purpose-built hardware store, garden centre or foundry. Those buildings, or parts of buildings, that may be partially conditioned could include a check-out counter in a purpose-built hardware store and workstations in a factory or aircraft hanger or even a church.

A capacity of 15 W/m² (4.3 MJ/hour) for either heating or cooling has been set as the minimum threshold for the definition of air-conditioning. The criterion of 15 W/m² is between 10% and 20% of the capacity of a typical heating or cooling system providing comfort temperatures to the full area of a building. Typically, the cooling needed for a building in climate zone 7 would be of the order of 100 W/m² to 120 W/m² and in climate zone 5, the heating would be of the order of 50 W/m². With a heat pump air-conditioner, the input power rates for climate zone 7 for cooling would be 30 W/m² and for climate zone 5 for heating, 20 W/m². Warmer climate zones have higher cooling needs and colder climate zones have higher heating needs. Typically, evaporative coolers would be under the 15 W/m² threshold.

Note that the definition of a conditioned space refers to the temperature in the space being controlled by air-conditioning. The definition of air-conditioning excludes services that cool or heat cold rooms and hot rooms. Therefore the NCC energy efficiency provisions do not apply to these process related rooms.

A room that is not conditioned in its own right, such as one providing a return air path or exhaust air path for conditioned air from an adjoining space, should be considered as a conditioned space. This means that the walls, floor and ceiling between it and an adjoining conditioned room are not part of the envelope and so do not require insulating. Likewise, in certain circumstances some internal spaces could be indirectly conditioned by air pressurisation occurring in adjoining areas. Expert advice may be needed to determine which spaces are indirectly conditioned.

Construction activity actions

This definition is used in [Part B](#) and only refers to construction activities that may have an effect on the final building design such as stacking of materials or floor to floor propping.

Critical radiant flux

A test in accordance with AS ISO 9239.1 determines the critical heat flux of a material. A higher value indicates better performance.

Curtain wall

A curtain wall is a facade fixed to the exterior of the building and may not be supported within frames at each storey. See **Panel Wall**.

Deemed-to-Satisfy Provisions

The Deemed-to-Satisfy Provisions make up the bulk of the NCC. The Deemed-to-Satisfy Provisions are deemed to satisfy the Performance Requirements. See [Part A2](#).

Deemed-to-Satisfy Solution

Means a solution which uses the Deemed-to-Satisfy Provisions to demonstrate compliance with the Performance Requirements. See [Part A2](#).

Defined flood level

See [Figure Schedule 3\(FLO\)](#).

Figure Schedule 3(FLO) Identification of defined flood level, flood hazard level and freeboard

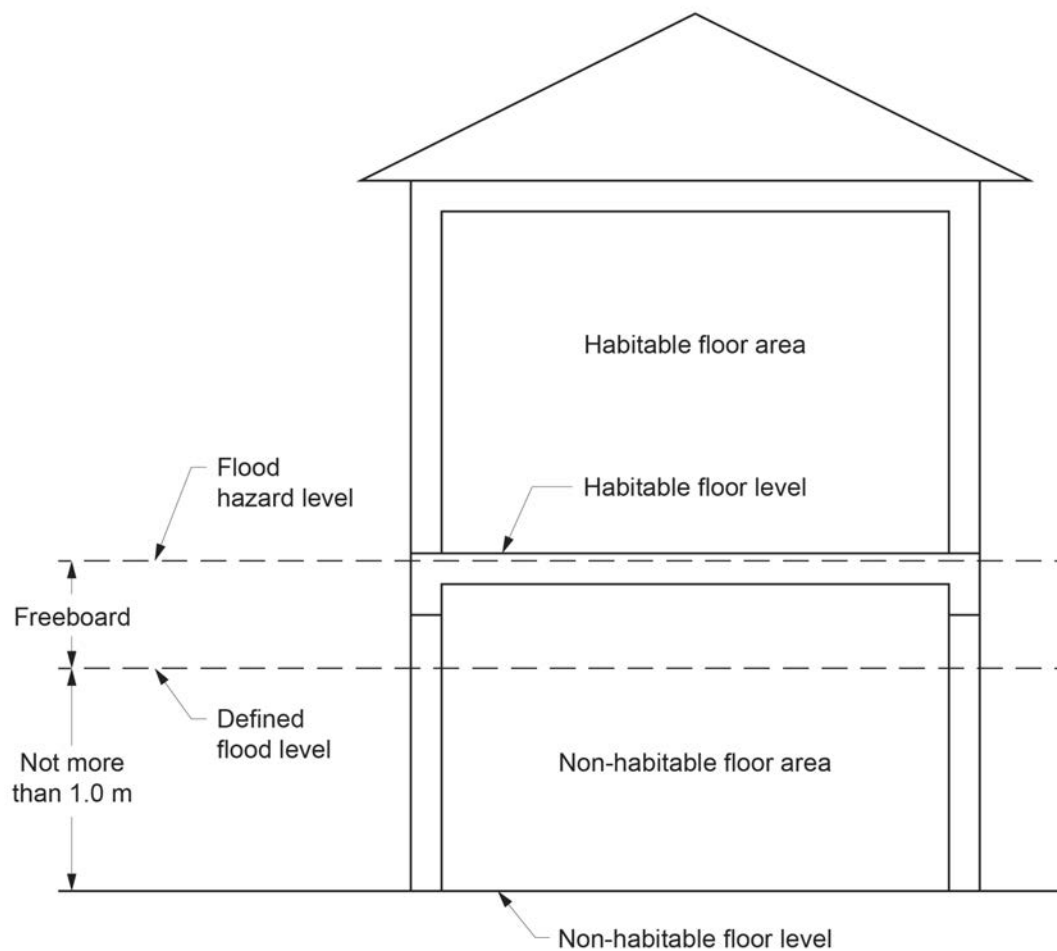

Designated bushfire prone area

Bushfire prone areas may be designated by a power under legislation. See your building regulatory body.

Early childhood centre

On 1 January 2012, the National Quality Framework was established under an applied law system comprising the *Education and Care Services National Law Act 2010* and *Education and Care Services National Regulations 2011* and will apply to most long day care, family day care, outside school hours care and preschools (or kindergartens).

A national applied law system is a way of establishing national laws whereby a host jurisdiction (in this case Victoria) passes a law (the *Education and Care Service National Law Act 2010*) and other jurisdictions adopt that law or pass corresponding legislation.

As a consequence a number of Parts in the NCC were aligned with the National Quality Framework.

The early childhood centre defined term refers to the term “centre-based”. Under the definitions contained in Chapter 1 of the *Education and Care Services National Regulations 2011*, a centre-based service means an education and care service other than a family day care service.

Effective height

Is a measure of the height of a building. It is used to determine when various provisions are required to be implemented and when certain concessions cannot apply.

Effective height is the vertical distance between:

- the floor level of the topmost storey in the building (excluding a storey which only contains equipment as listed); and
- the floor level of the lowest storey which is included in the determination of rise in storeys (see [C1.2](#)).

Electric passenger lift

An electric passenger lift may also be a combined electric passenger and goods lift.

Electricity network substation

Electricity network substations are buildings containing high and low voltage equipment that provide essential electricity to a district or part of a city. They may be stand-alone buildings or located within multi-classified buildings. These installations provide an essential public service to the community on which other essential services such as water supply depend. Consequently they are licenced entities which differentiate them from a customer substation that supplies electricity only to the dedicated building in which it is contained.

Electrohydraulic passenger lift

An electrohydraulic passenger lift may also be a combined electrohydraulic passenger and goods lift.

Envelope

In the NCC, this term is not limited to the building's outer shell, but also includes those continuous elements that separate a conditioned space from a non-conditioned space. For example, the floor between a plant room and an office space or the wall between a carpark and a shopping centre may be part of the envelope, rather than the outer shell. A non-conditioned space may be included within the envelope under certain circumstances.

Equivalent

A Performance Solution may achieve compliance with the Performance Requirements by achieving *equivalence* with the Deemed-to-Satisfy Provisions.

Evacuation route

The path a person uses to evacuate a building. It starts at the most remote part of a building and finishes at a "safe place". This can be in the building, or a road or open space. It is not always the point of exit from a building.

An evacuation route includes the evacuation path within a sole-occupancy unit of a Class 2 or Class 3 building or Class 4 part of a building, as well as an exit from such a unit. This term is different from a path of travel to an exit, which begins at the door to such sole-occupancy units.

Evacuation time

Is the calculated time from when an emergency begins until the last occupant reaches a "safe place".

It includes the time taken for any alarm to detect a fire and give warning. Added to this is the time taken for occupants to start to evacuate the building.

This "time" will depend on a number of factors, some of which may be influenced by an "emergency management system", including:

- the type of alarm or warning given;
- whether the occupant initially recognises the alarm or warning;
- whether the occupant decides to investigate or ignore the alarm;
- whether the occupant decides to warn other people in the building;
- the time taken for all occupants to move through the building until reaching a "safe place".

Exit

An exit can be any of the building elements listed. It must lead to a road or open space or a horizontal exit leading to another fire compartment.

An exit starts at the beginning of the first relevant building element listed in the definition.

Examples

The start of an exit includes:

- the top of the first riser in a required open stairway;
- the doorway leading into a required fire-isolated stairway, fire-isolated ramp or fire-isolated passageway; and
- a required doorway which leads directly to a road or open space.

The exit finishes when a person reaches, as the specific circumstances require:

- a road or open space;
- in the case of a horizontal exit, another fire compartment, which in turn leads to a road or open space; or
- in the case of a non-fire-isolated stairway or ramp, the level providing direct egress to a road or open space.

Expert Judgement

Expert judgement may be used to assess a Performance Solution or Deemed-to-Satisfy Solution against the relevant Performance Requirements, or against the Deemed-to-Satisfy Provisions if use is being made of an equivalence Assessment Method.

External wall

An external wall is on the outside of a building and usually requires weatherproofing ([Part F1](#)).

It is possible for a wall to be partially an external wall and partially an internal wall. (See [Figure Schedule 3 \(EW\)](#)). Where the expressions “internal wall” and “external wall” are used, they exclude a “common wall”.

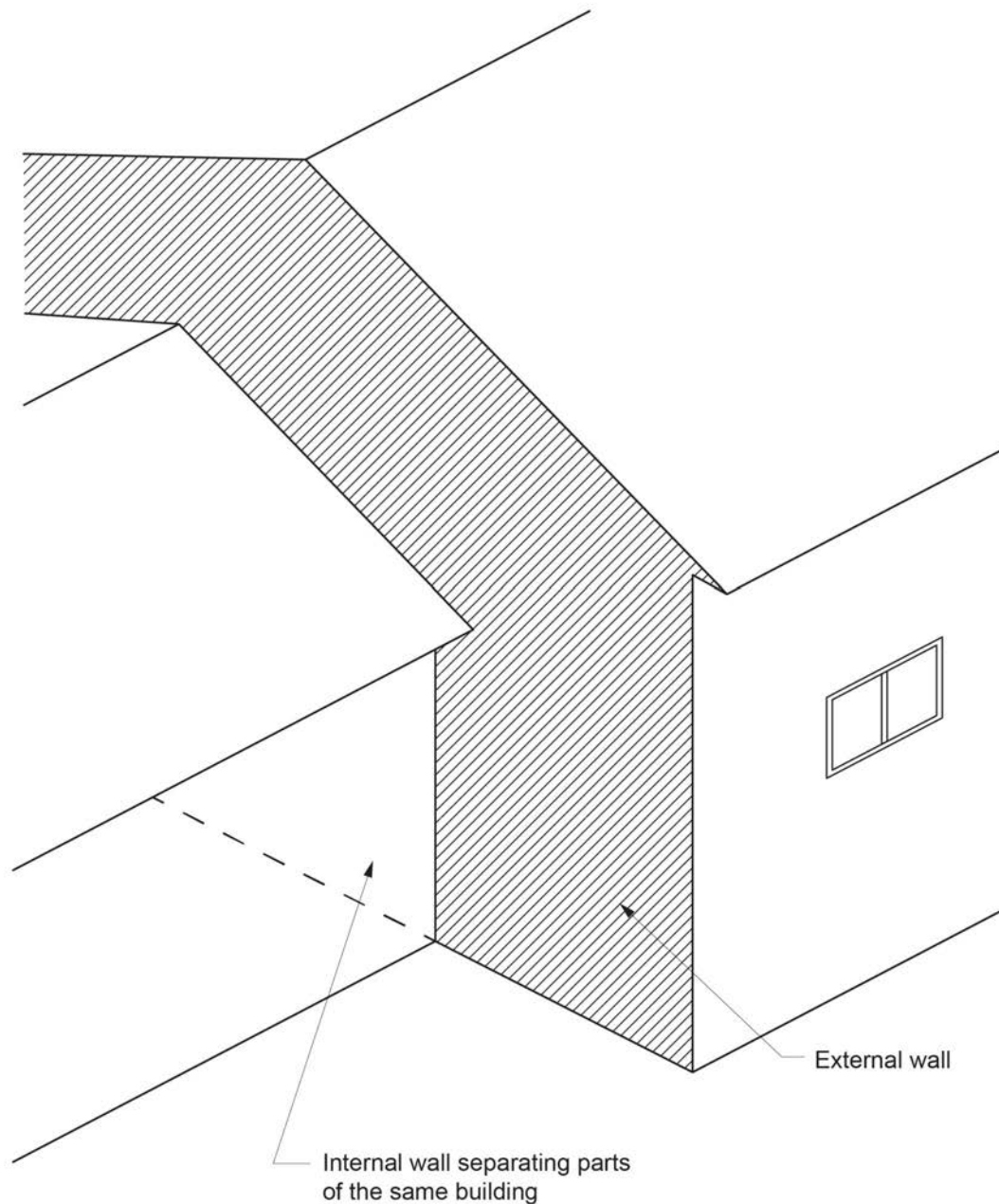
Figure Schedule 3(EW) External walls**Fabric**

This includes all of the non-service elements of a building such as the roof, walls, glazing and floor, that impact upon the building's thermal performance. The fabric may impact upon a building's thermal performance through its insulating ability, or through its thermal inertia or thermal capacitance, which is the ability to slow energy flow and so delay or reduce the transfer of heat.

Farming

This definition sets out activities which, for the purposes of the NCC, constitute farming and is mainly used to determine whether a building can be considered a farm building or a farm shed.

This definition relates to the context in which it is used and should be read in conjunction with farm building, farm shed, and farm vehicle definitions for appropriate application of the NCC Deemed-to-Satisfy Provisions.

Farm building

Buildings used for farming-type purposes are often very diverse in nature, occupancy and use. There are a number of conditions in this definition to outline the specific instances where a Class 7 or Class 8 building can be considered a farm building for the purposes of the NCC. This is to ensure that the Deemed-to-Satisfy Provisions for farm buildings are appropriate for a particular building in question.

The definition sets out three main criteria that a building must meet for it to be considered a farm building. These criteria can be described as:

- the use and location of the building;
- the maximum number of occupants and occupant density in the building; and
- a maximum floor area of the building.

It is recommended that this definition be read in conjunction with the definition of “farming”.

Refer to [Part H3](#) for specific requirements for farm buildings.

Farm shed

Buildings used for farming-type purposes are often very diverse in nature, occupancy and use and farm sheds can be generally considered as very basic buildings used for farming that are unlikely to contain people most of the time. Farm sheds could be used to protect stock from the elements, store hay or produce, or house farm vehicles when not in use. They also may not be fully enclosed.

There are a number of conditions in this definition to outline the specific instances where a Class 7 or Class 8 building can be considered a farm shed for the purposes of the NCC. This is to ensure that the Deemed-to-Satisfy Provisions for farm sheds are appropriate for the particular building in question.

The definition sets out five criteria that a building must meet for it to be considered a farm shed. These criteria can be described as:

- single storey;
- occupied infrequently and for relatively short periods of time;
- use and location of the building;
- maximum number of occupants in the building; and
- a range of allowable floor areas.

It is recommended that this definition be read in conjunction with the definition of ‘farming’.

Refer to [Part H3](#) for specific requirements for farm sheds.

Farm vehicle

This definition outlines that where a vehicle is used in relation to farming (see definition of farming) it can be considered a farm vehicle for the purposes of the NCC.

Along with other criteria, the definitions of farm building and farm shed include buildings used to store one or more farm vehicles.

Refer to [Part H3](#) for specific requirements for farm buildings and farm sheds.

Fire brigade

This term only refers to statutory authorities established under an Act of Parliament having as one of its functions the protection of life and property from fire and other emergencies. It may be a professional brigade with full-time firefighters, or a volunteer brigade. Many companies employ their own private fire services. The standard of these private fire services varies greatly. They are excluded from the definition of a fire brigade.

Fire brigade station

The definition of fire brigade station contains a reference to ‘a government operated premises’ which serves to exclude privately-operated fire equipment which is not intended to be used with fire hydrant systems.

Fire compartment

A fire compartment contains walls, floors and the like creating a compartment (or “box”) of any shape used to limit the spread of fire to another compartment or part of a building.

Example

If any floor has an opening for an open stairway or escalator, a fire could spread through the opening—that floor would not form the boundary of a fire compartment.

If there are no distinct fire barriers erected, then the whole building forms a fire compartment.

If a Performance Solution is used, the building elements used to form a fire compartment must have appropriate fire

separation from the remainder of the building as determined by fire engineering principles. Note that FRLs are only used in the Deemed-to-Satisfy Provisions.

If the Deemed-to-Satisfy Provisions of [Part C3](#) are used, the building element used to form a fire compartment must have the fire-resistance level (FRL) of a fire wall required by [Specification C1.1](#).

Sole-occupancy units are not generally regarded as fire compartments except for [E1.4](#) for fire hose reels.

Fire hazard properties

A material's fire hazard properties are an indication of its susceptibility to the effects of flame or heat, particularly during the early stages of a fire.

Fire-isolated passageway

A fire-isolated passageway protects people within a passageway from fire while evacuating. The whole passageway must be fire-protected from a fire outside the passage, including the floor, walls, ceiling, roof, any doors or other openings. The Deemed-to-Satisfy Provisions for fire-isolated passageways are in [D2.11](#). The provisions relating to the protection of openings are in [C3.8](#).

Fire-isolated ramp

See fire-isolated passageway.

Fire-isolated stairway

See fire-isolated passageway.

Fire-protected timber

Used for the concessions under [C1.13](#), fire-protected timber must comply with [Specification C1.13a](#) and may be used in certain situations where a building element is required to be non-combustible.

Fire-protective covering

While not fire rated, these elements have been found to provide nominal protection from the spread of fire of at least 20–30 minutes.

The NCC lists materials deemed to be fire-protective coverings. The fixing in each case must accord with normal trade practice. There must be no gaps at the joints in the sheets, and the joints must be sealed in the usual manner. Standard grade 10 mm or 13 mm plasterboard is not acceptable as a fire-protective covering.

Fire-resistance level (FRL)

Used only in the Deemed-to-Satisfy Provisions, the FRL of a building element is determined by conducting the Standard Fire Test on a prototype in accordance with AS 1530.4.

Example

If the NCC requires a building element to have an FRL of 120/60/30, this means that the element must maintain, when tested in accordance with AS 1530.4:

- structural adequacy for a period of 120 minutes;
- integrity for a period of 60 minutes; and
- insulation for a period of 30 minutes.

Fire-resisting

Applies to fire-resisting building elements, including structural members and non-loadbearing components, such as cladding, doors, windows and the like.

Fire safety system

These systems may be active systems, passive systems, or any combination of the two.

Examples

Some examples of fire safety systems:

Active systems

- emergency warning and intercom systems;
- emergency lighting;
- exit signs;
- sprinkler systems;
- fire hydrant systems;

- fire hose reel systems;
- smoke and heat vents;
- mechanical smoke-exhaust systems; and
- portable fire extinguishers.

Passive system

- fire-isolated stairways, ramps and passageways;
- fire walls; and
- other fire-resisting building elements.

Fire-source feature

Used in Deemed-to-Satisfy Provisions to describe a possible fire source external to the building from which a fire could spread to the building. See [Figure Schedule 3\(FSF\)](#).

A fire-source feature includes the far side of the road, and the side or rear boundary of an allotment. It also includes the far side of lakes, rivers and the like where the construction of buildings is unlikely. These represent the worst-case scenario for the spread of fire from another building. Even if a building on an adjacent allotment is set back from a boundary, the NCC assumes it could be demolished and another building constructed on the boundary.

Figure Schedule 3(FSF) Allotment plan showing fire-source features

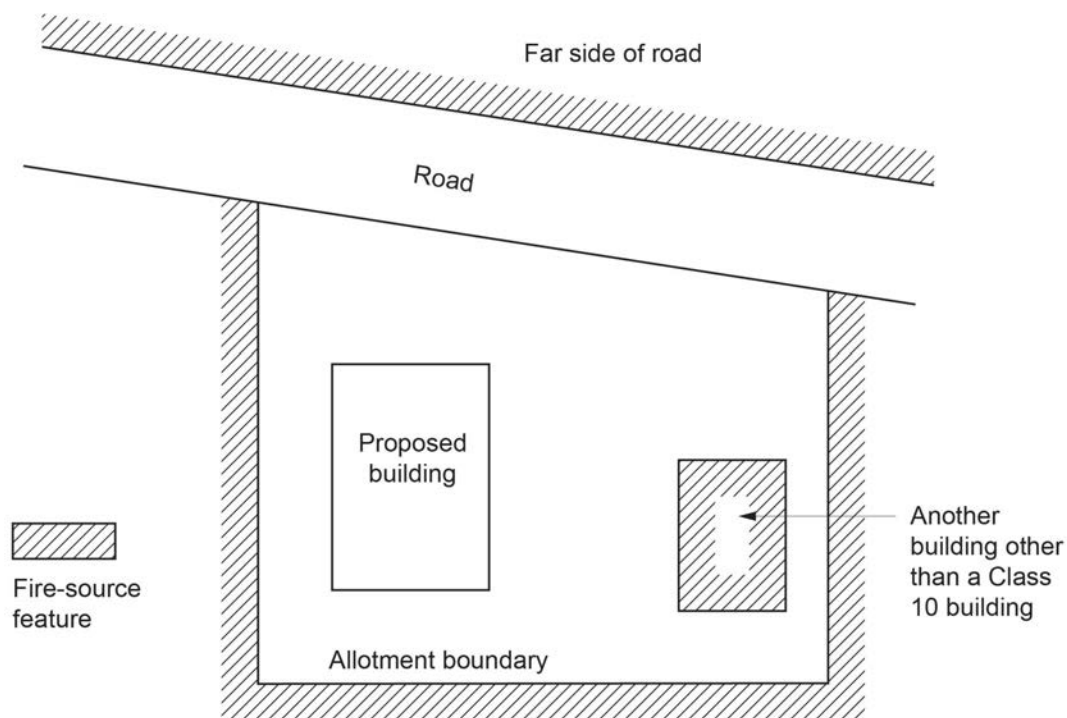

Note that the term “fire-source feature” does not necessarily apply to a building—it relates to a potential source of fire. That potential may be realised in the future construction of a building. For this reason, the fire-source feature is not simply a line on the ground, nor a point at the top of a building; it is a continuous plane rising above that line or point.

In this sense:

- a line drawn out horizontally from a building to a fire-source feature will hit that feature; and
- form a 90° angle with a line drawn down from the point at which it hits the fire-source feature to the ground, or the top of the adjoining building.

However, some Deemed-to-Satisfy Provisions of the NCC limit the height above a building at which the fire-source feature remains active (see [Clause 2.1 of Specification C1.1](#)).

The reason for the exclusion of Class 10 buildings on the same allotment is that they are generally small and have a low fire load.

Fire wall

Fire walls separate fire compartments. To avoid the spread of fire to another part of the building, a fire wall must extend from the fire-rated floor of a storey to the underside of the fire-rated floor above, or to a non-combustible roof covering.

A “fire-resisting” wall is not necessarily a “fire wall”. A fire wall can sometimes be an external wall. See [C2.7](#) and [Figure C2.7\(3\)](#) of this Guide.

Flammability Index

A test performed in accordance with AS 1530.2 will determine the flammability index of a material.

Flight

A flight is the part of a stairway that has a continuous slope created by the nosing line of the stair treads. Quarter landings are not considered part of a flight. However, winders are considered part of a flight. See [Figure Schedule 3\(FLI\)](#).

Figure Schedule 3(FLI) Identification of stair flights

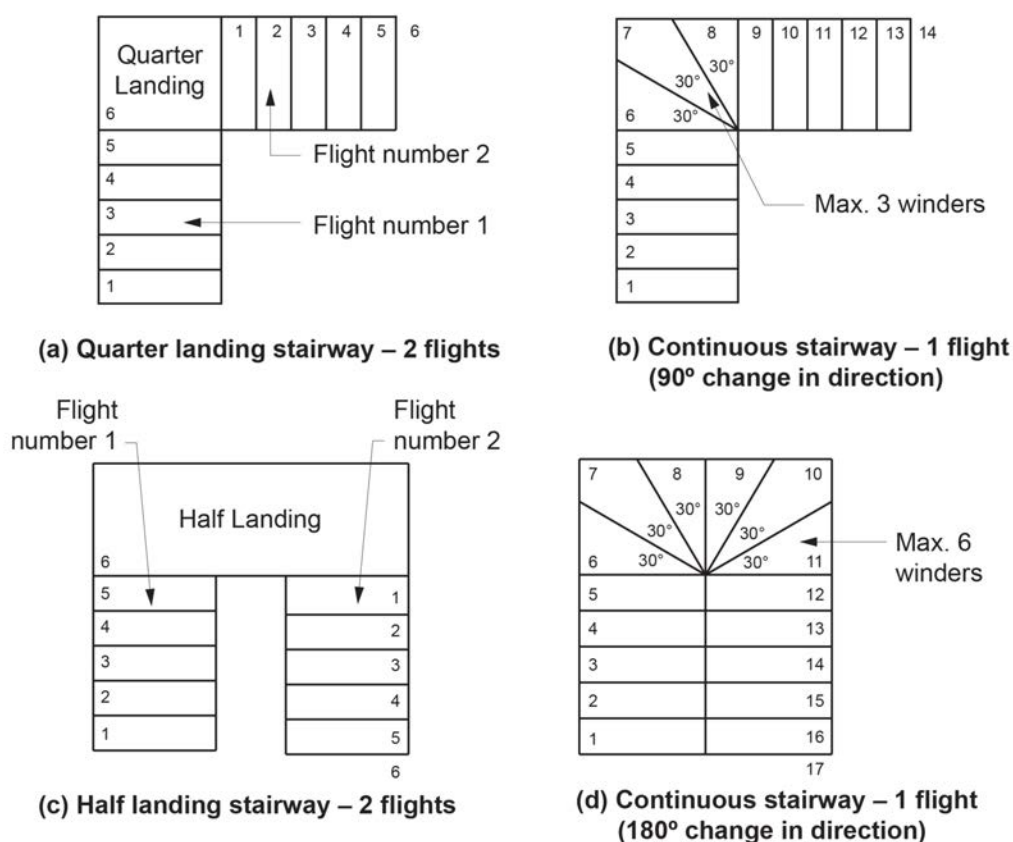

Flood hazard level

See [Figure Schedule 3\(FLO\)](#).

Floor area

When applied to a building or storey, the floor area includes all the space capable of being used. It includes occupiable outdoor areas that have a use that contributes to fire load, any roofed area, canopy, verandah or covered walkway, etc.

Floor area is used in a number of different contexts in the NCC. It is therefore necessary to define each of these contexts:

- In relation to a building—the sum of the areas of all storeys.
- In relation to a storey—the floor area of the storey includes any enclosing walls. Where there is no enclosing wall in a part of a storey, those areas which may be used for storage, or other purposes, by occupants must be included as appropriate. It therefore includes occupiable outdoor areas that have a use that contributes to fire load, any roofed area, including a canopy, verandah or covered way if it contributes to the functioning of the building. Internal walls, columns, shafts, stairways, ramps or the like are not deducted. See [Figure Schedule 3\(FA\)\(1\)](#).
- In relation to a room—the bounding walls determine the limits of the floor area. Internal walls, columns, stairways, ramps or the like are not deducted. See [Figure Schedule 3\(FA\)\(2\)](#).

Definitions

- In relation to a fire compartment—the fire compartment may not be bounded by walls in all places. If this is the case and a roofed area contributes to the fire load, it should be considered as part of the floor area. See [Figure Schedule 3\(FA\)\(3\)](#).
- In relation to an atrium—see [Figure Schedule 3\(FA\)\(4\)](#).

Figure Schedule 3(FA)(1) Plan showing floor area of a storey

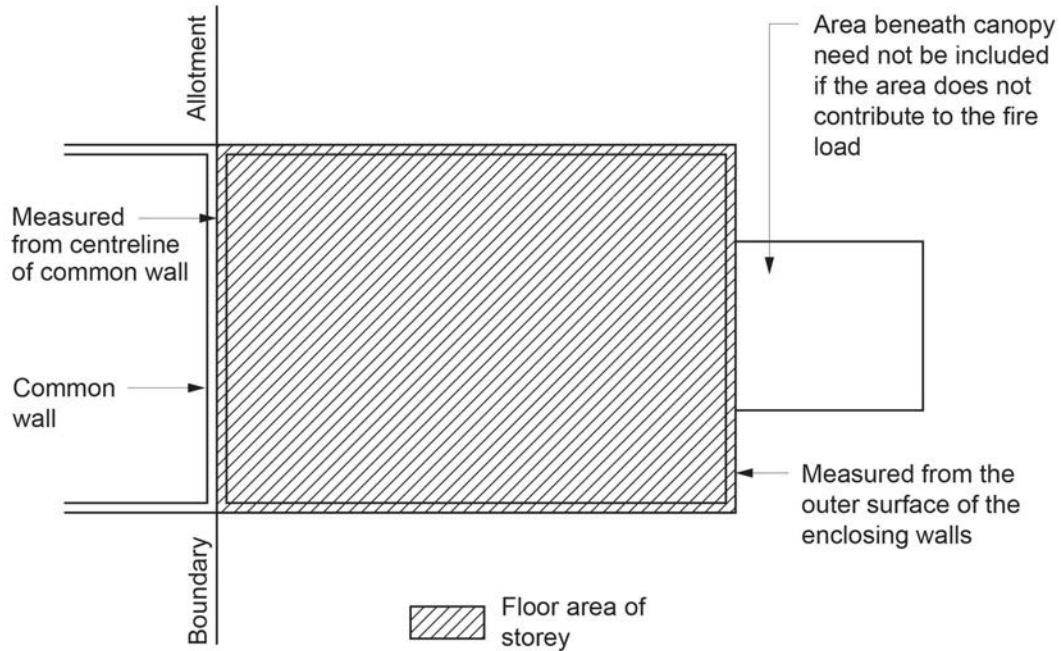

Figure Schedule 3(FA)(2) Plan showing floor area of a room

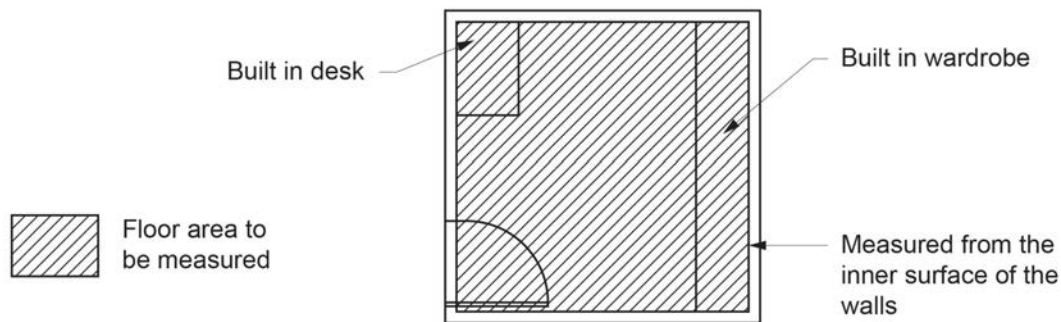

Figure Schedule 3(FA)(3) Plan showing floor area of a fire compartment

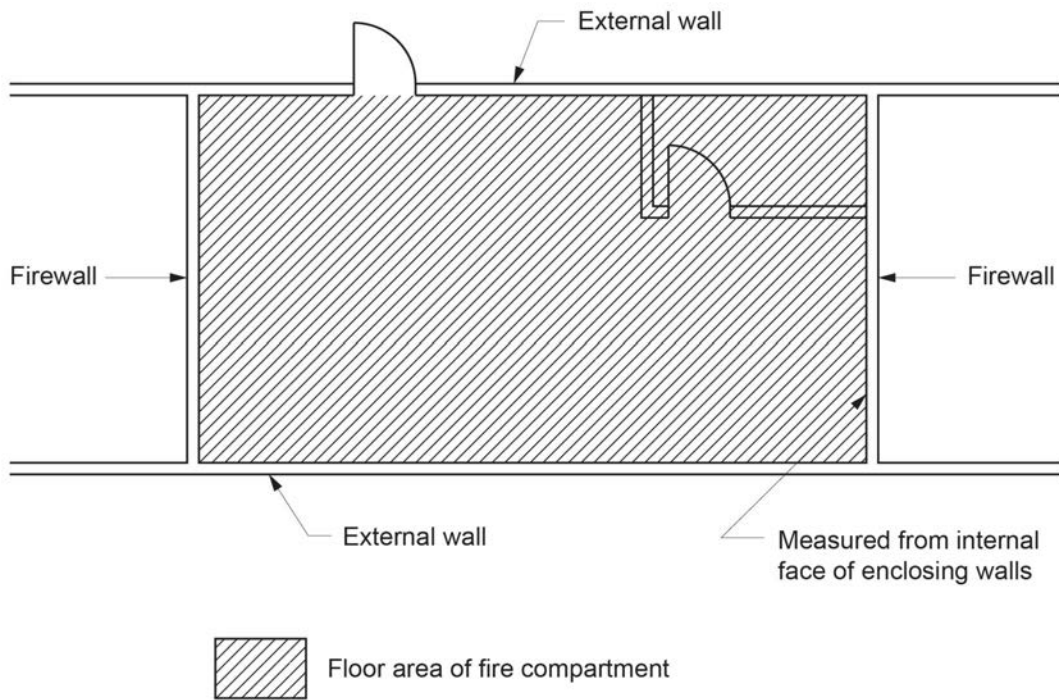
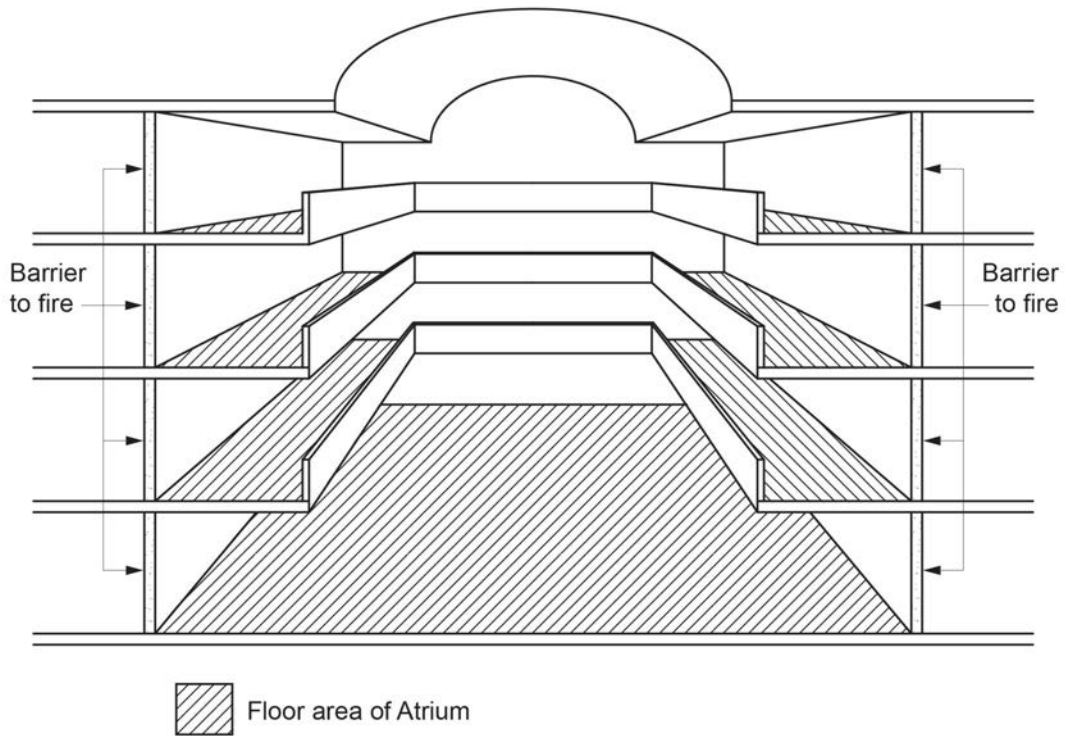

Figure Schedule 3(FA)(4) Floor area of an atrium



Freeboard

See [Figure Schedule 3\(FLO\)](#).

Functional Statement

Is a term not used within Volume One, however Functional Statements are used in this Guide as an aid to the interpretation

of the NCC and not for determining compliance. Functional Statements are statements which describe how buildings and building elements achieve the Objectives.

Glazing

The glazing definition needs to be read in conjunction with the definition of a window and roof light. It can include a glazed door. For the purposes of [Section J](#), the glazing provides an aperture by which light and energy can flow into or from the conditioned space. Glazing includes the glass and any frame system.

Group number

[Specification C1.10](#) sets out the requirements for Group 1, Group 2, Group 3 and Group 4 materials. A test in accordance with either AS ISO 9239.1 or AS/NZS 3837 determines the group a material belongs to. The NCC permits the installation of Group 1, Group 2 and Group 3 materials. Group 1 materials are the best performing materials. Group 4 materials are the worst performing materials.

Habitable room

Only applies to Class 2 and Class 3 buildings and Class 4 parts of buildings.

Health-care building

The definition of a health-care building means a building whose occupants or patients undergoing medical treatment, need physical assistance to evacuate the building during an emergency and includes a nursing home or similar facility for people who are sick or have a disability and require full-time care. Therefore, a healthcare building could include a residential aged care building in which occupants are provided with some level of medication, and need assistance to evacuate.

Health-care buildings also include day-care surgeries or procedure units. They are distinguished from a doctor's or dentist's surgery, because if an evacuation became necessary in these places, patients would probably not need assistance in evacuating.

In a health-care building, patients may be incapable of movement, and require the assistance of another person to evacuate. They might also require medical supervision for a while after treatment.

Health-care buildings are not to be interpreted to include aged care buildings. It should be noted that the NCC contains differing requirements for Class 9a health-care buildings and Class 9c buildings.

House energy rating software

The definition describes the software accredited under the Nationwide House Energy Rating Scheme (NatHERS). NatHERS is the Australian governments' scheme that facilitates consistent energy ratings from software tools which are used to assess the potential thermal efficiency of dwelling envelopes.

Illuminance

Used only in the Performance Requirements of [Part F4](#) to describe the amount of natural and artificial light required for a building.

Illumination power density

This term is more wide-reaching than the simpler "lamp power density" term also used for the sole-occupancy units of Class 2 buildings and Class 4 parts. It needs to be calculated taking account of the losses from ballast, current regulators and integral control devices associated with the lighting system including track and flexible lighting systems, and fixed lighting that is part of modular furniture and workstation lights. However, socket outlets for intermittent use such as for floor standing lamps, desk lamps, etc. are not included as it is not possible to control them through the building control process. The calculation of illumination power density does not include losses elsewhere in the system, such as in the distribution cabling throughout the building.

Insulation

Insulation is the third criterion used when specifying an FRL.

Example

If the NCC requires a building element to have an FRL of 120/60/30, this means that the element must maintain, when tested in accordance with AS 1530.4:

- structural adequacy for a period of 120 minutes;
- integrity for a period of 60 minutes; and
- insulation for a period of 30 minutes.

A building element fails the insulation criterion if the average temperature of the unexposed face of the test specimen rises by more than 140 K (i.e. 140 degrees Kelvin) above the initial temperature. It also fails if the temperature of the unexposed face of the test specimen rises by more than 180 K above the initial temperature.

Integrity

Integrity is the second criterion used when specifying an FRL. See example under “insulation” definition.

The test under AS 1530.4 considers that a building element has failed the integrity criterion when either the element collapses, or the element develops cracks, fissures or other openings through which flames or hot gases can pass.

Internal wall

All walls that are not external walls are internal walls.

Lamp power density

This term was developed in order to simplify the statement of requirements and to simplify checking for sole-occupancy units of Class 2 buildings and Class 4 parts. It relates only to the lamp and does not include the power lost by any ballast, current regulator or control device. However, socket outlets for intermittent use such as for floor standing lamps, desk lamps, etc. are not included as it is not possible to control them through the building control process. The maximum power of a lamp is usually marked on the fitting as the maximum allowable Wattage.

Latent heat gain

This term refers to the heat used to vaporize a liquid without causing a change in temperature, such as heat used to generate steam from heated water at 100°C. Also included, in the NCC context, is the energy in the moisture from the human body.

Lightweight construction

The NCC lists building materials of “lightweight construction”. These materials need protection to preserve their integrity from fire and other damage. This is because they are more susceptible to damage than other forms of fire protection. For example, masonry wider than 70 mm and materials like concrete, which typically do not contain soft materials, are not deemed to be lightweight construction. See [C1.8](#) and [Specification C1.8](#).

Luminance contrast

This term is used in provisions for access for people with a disability. Luminance contrast is the measurement of the amount of light reflected from one surface or component, compared to the amount of light reflected from the background or surrounding surfaces. The majority of people who are blind or vision impaired have some vision. The provision of sufficient luminance contrast between components or surfaces and their backgrounds assists in their identification and use.

Massive timber

This term refers to solid and composite timber elements, such as solid timber, cross laminated timber (CLT), laminated veneer lumber (LVL), glulam and nail laminated timber (NLT), which are at least 75 mm thick as measured in each direction. [Specification C1.13a](#) contains requirements for when massive timber is used as fire-protected timber.

Mezzanine

A “mezzanine” must be part of a room. If an intermediate floor is enclosed by a wall it is no longer within another room, and is therefore no longer a mezzanine. Such rooms are sometimes called “mezzanines” by the layperson. This does not mean they are classified as such by the NCC. See [Figure Schedule 3\(ME\)](#).

Figure Schedule 3(ME) Section showing when an enclosed floor is regarded as a storey

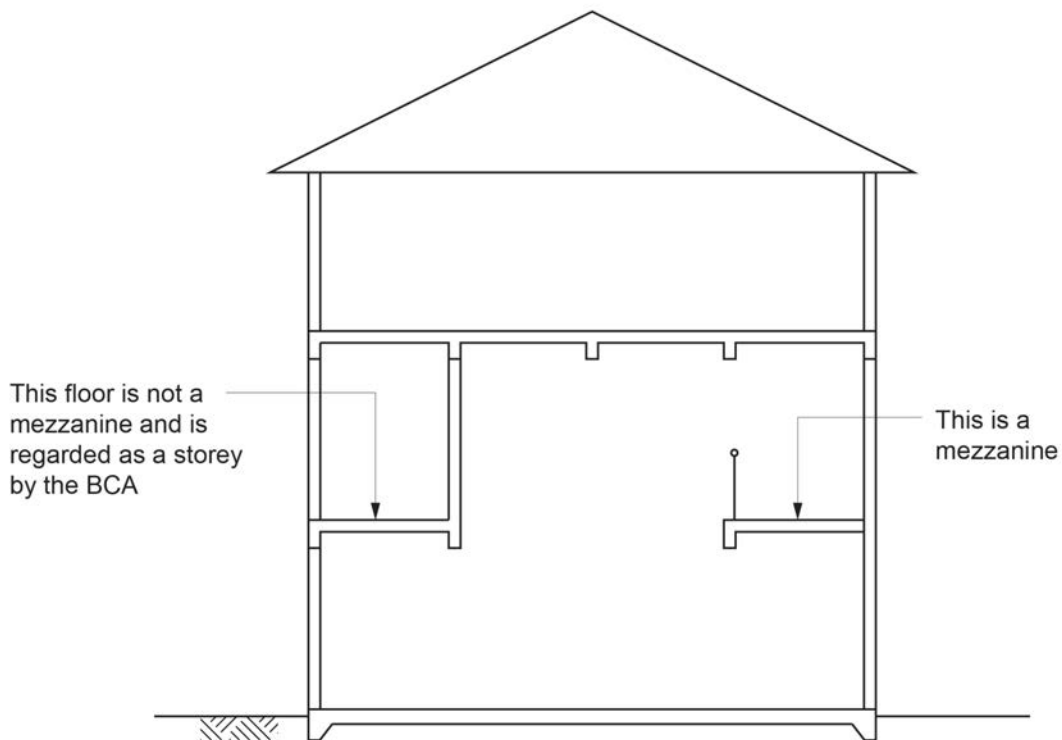

Occupant traits

This term is used to describe the characteristics of the occupants and their associated requirements in relation to a habitable room or space.

For example, in relation to a bedroom, the following occupant characteristics and associated requirements should be considered:

- Characteristics: height, mobility and how often the space will be used.
- Requirements: a sleeping space and a space to undertake leisure activities.

Occupiable outdoor area

Occupiable outdoor areas in buildings are often very diverse in nature, occupancy and use. Occupiable outdoor areas can include rooftop bars, restaurants and nightclubs. Other areas are included, such as a balcony provided to an office building.

The definition of occupiable outdoor area contains a reference to a 'space on a roof, balcony or similar part of a building' which covers a wide variety of spaces.

There are a number of conditions in this definition which outline the criteria where a space on a roof, balcony or similar part of a building can be considered an occupiable outdoor area for the purposes of the NCC. These include the following:

- That the area is 'open to the sky'.
- Where people can access the occupiable outdoor area (i.e. spaces used solely for maintenance are excluded).
- That the area is not an open space (because an occupant of open space need not re-enter the building, and is therefore subjected to low hazard).

The specific requirements for occupiable outdoor areas are in Part G6.

Objective

Is a term not used within Volume One, however Objectives are used in this Guide as an aid to the interpretation of the NCC and not for determining compliance. An Objective means a statement which is considered to reflect community expectations.

Open-deck carpark

The Deemed-to-Satisfy Provisions contain a number of concessions for open-deck car parks. The concessions are based on the amount of natural ventilation available. Ventilation is needed for the dissipation of car fumes and also for heat and smoke during a fire. An open-deck car park may be a whole, or part, of a building.

Open space

Egress from a building must be to a road or open space. An open space must be open to the sky and connect directly to a public road. See [D2.12](#).

The NCC uses the term “road” and “public road” as the case requires. A “road” can be a private or public road. The appropriateness of a type of road for the purposes of the NCC is dependant on rights of access to the road. A “public road”, as the name suggests, is a road available for use by the public and is usually controlled and maintained by or on behalf of a government body. As a consequence, a public road is considered to be a more permanent feature when compared to other types of road such as a private road.

Open spectator stand

Traditionally called a “grandstand”. The Deemed-to-Satisfy Provisions contain a number of concessions for open spectator stands. Concessions are based on the amount of natural ventilation, at the front of these stands, during a fire. They may be a whole, or part, of a building.

Other property

Used to describe nearby buildings and land requiring protection for structural, fire or drainage reasons. The purpose of including a road as part of “other property” is that in certain parts of the NCC, a road, or the people using it, may need protection.

Example

The NCC takes into consideration protection from collapse of a building or any part of it on to the road, and in some States and Territories protection from collapse of a road into a building/construction excavation.

Outside air economy cycle

This term describes a mode of operation of an air-conditioning system in which the quantity of outside air is increased beyond that needed by the mechanical ventilation requirements of [Part F4](#) in order to provide free cooling. Free cooling can be initiated when cooling is required by the air-conditioning system and the outside air temperature is below the set-point temperature of the conditioned space.

Panel wall

The difference between a panel wall and a curtain wall is that a panel wall is supported at each storey, and a curtain wall is not.

Patient care area

Includes “ward areas” and “treatment areas”.

Performance Requirement

See [Part A2](#).

Performance Solution

See [Part A2](#).

Personal care service

Personal care services include any combination of the listed services. The definition is used in defining an aged care building. (See comments on the definition of aged care building).

Piping

This term may have a different meaning in other parts of the NCC or in NCC referenced documents, for example, in relation to sprinklers. This definition of piping is only applicable to [Section J](#) where it is used mainly for thermal insulation provisions.

Pressure vessel

This term refers to enclosed vessels subjected to internal or external pressure. Gas cylinders are an example of a pressure vessel, however gas cylinders installed in small appliances are not intended to be captured. The term also does not apply to boilers, storage tanks intended for storing liquids where the pressure at the top of the tank is not more than 1.4 kPa above or 0.06 kPa below atmospheric pressure, domestic hot water heaters and pressure vessels associated with fire suppression systems.

Primary building element

Those materials and constructions subject to attack by termites causing structural problems. This includes stairs and ramps. Excluded are building elements which provide bracing to a wall, but this is not designed as part of their function. An example would be plasterboard not required for bracing or an external cladding.

Private bushfire shelter

The term is used to describe a Class 10c building. The provisions for Class 10c private bushfire shelters are contained in the Housing Provisions (Volume Two) of the NCC.

Private garage

To be classified as a private garage (and therefore a Class 10a building or part), a structure can only contain a maximum of three vehicle spaces, unless the garage is associated with a Class 1 building.

A building designed to accommodate three-or-less vehicle spaces carries a comparatively low fire load, even if used commercially. Thus, there is not much difference between the fire risk from a domestic private garage and one used commercially.

If a garage is not associated with a Class 1 building, and contains more than three vehicle spaces, it is a carpark and therefore a Class 7 building or part.

Product Technical Statement

A Product Technical Statement is a form of documentary evidence that states that a building material, product, form of construction or design (subject to any specified conditions or limitations) complies with relevant requirements of the NCC.

Professional engineer

Includes a professional engineer eligible for registration with Engineers Australia's National Engineering Register (NER). Some States and Territories define "professional engineer" differently. Such definitions override the NCC definition.

Public corridor

Not all corridors and hallways are public corridors. A public corridor must be enclosed and provide egress from more than one sole-occupancy unit. Examples include passages leading from hotel suites, lift lobbies and foyers in high-rise buildings. Public corridors can be required to provide egress to a required exit.

R-Value

The R-Value of a component relates to the component material itself, and does not include any surface coatings, air gaps or surface resistances. Except for ductwork, piping, heat exchanger and tank insulation, R-Values are rarely used independently, but can be used to express a component's contribution to an insulating system, in which case, the thermal resistance expression for the system would become Total R-Value.

Reference building

A reference building is used to determine the maximum annual energy consumption allowed. This is done by applying the Deemed-to-Satisfy Provisions, along with certain stated criteria, to a proposed design. The annual energy consumption calculated is then used to assess the energy efficiency of the Performance Solution.

Reflective insulation

This term is used in AS/NZS 4859.1 and covers a range of insulating products that have one or more reflective surfaces. Reflective insulation is one example of sarking-type material.

Renewable energy

The definition of renewable energy clarifies what are the sources of operational energy that do not result in significant greenhouse gas emissions. Examples given include solar, wind, hydro-electric, wave action and geothermal. For the purpose of the defined term, an on-site renewable energy source does not include GreenPower.

Required

When used in the Performance Requirements, the term means required to meet the Performance Requirement. When used in the Deemed-to-Satisfy Provisions, it means required to meet those provisions.

Residential aged care building

Applies only to buildings housing residents with mental or physical impairments caused by the ageing process. Such impairments require that patients need assistance in their daily lives.

People are employed to assist and care for these residents. Hence, the building requirements aim to provide a more amenable environment for the residents.

The definition applies to Class 3 and Class 9a buildings. The NCC contains a number of concessions for Class 3 residential aged-care buildings. See [C3.11](#) and [Specification C1.1](#).

Resident use area

Only applies to Class 9c buildings.

Resistance to the incipient spread of fire

Refers to the ability of a ceiling to prevent the spread of fire and thermally insulate the space between the ceiling and the roof, or floor above. "Resistance to the incipient spread of fire" is superior to "fire-resistance" because it requires a higher standard of heat insulation. Refer to AS 1530.4.

Rise in storeys

[C1.2](#) describes how to calculate the rise in storeys.

Roof light

The definition provides a distinction between a window and a roof light based on its angle to the horizontal.

Safe place

A safe place provides a final refuge from a fire, such as a road or open space at the end of an exit. It can also be a temporary “haven” or “refuge” to protect people while they are evacuating during a fire. The term is only used in the Performance Requirements. Safe places can be inside or outside a building, and must provide a person with protection from a fire and then allow them to safely escape to a road or open space.

Example

- fire-isolated stairways;
- fire-isolated ramps;
- fire-isolated passageways; and
- an adjacent fire compartment.

Sanitary compartment

The term refers to a room or space which contains a closet pan or urinal. This can include rooms such as a water closet, a bathroom, a shower room or the like which also contains a closet pan or a urinal. The term additionally refers to a “space” which may contain a closet pan or urinal. An example would be a bank of toilets where each individual cubicle is considered a sanitary compartment. [Figure Schedule 3\(SC\)](#) provides differing configurations of sanitary compartments.

Figure Schedule 3(SC) Identification of sanitary compartments

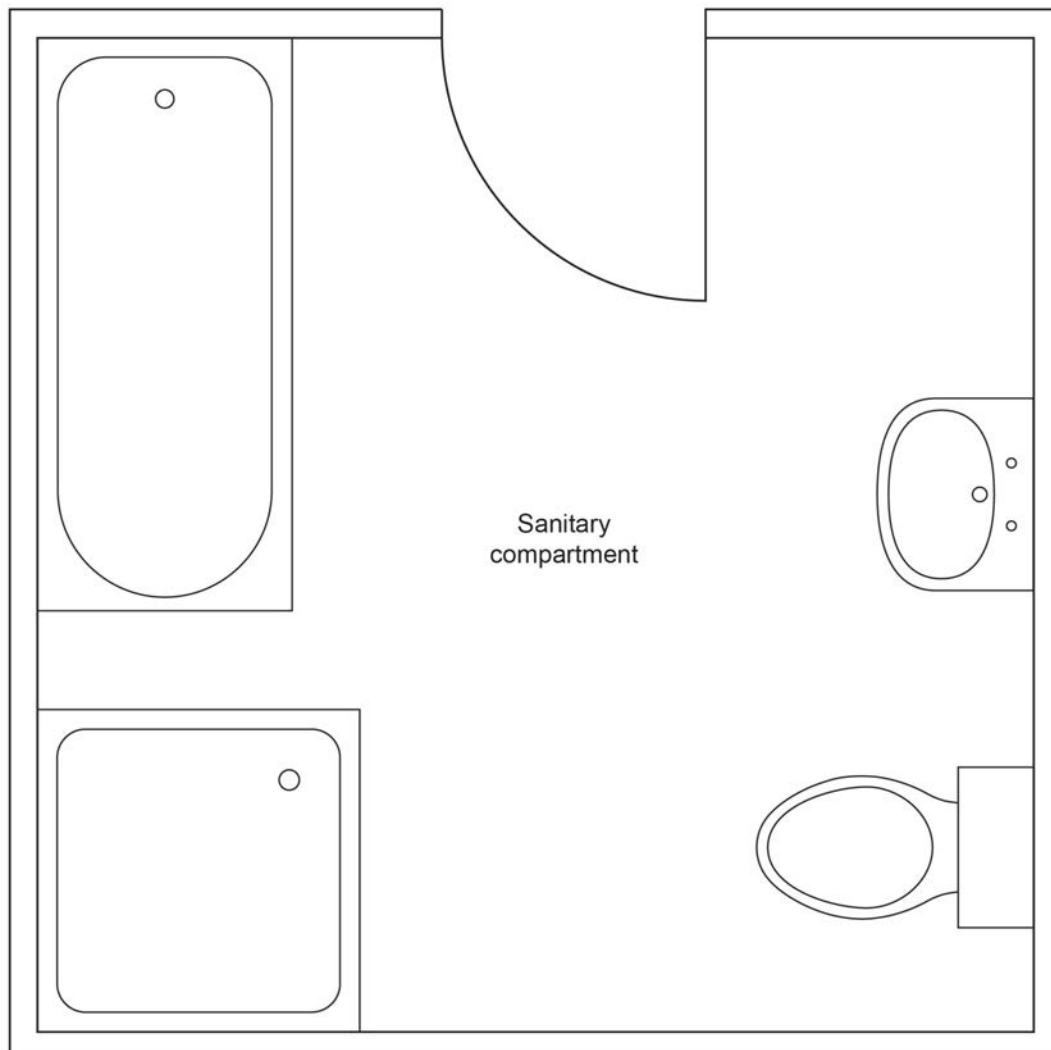

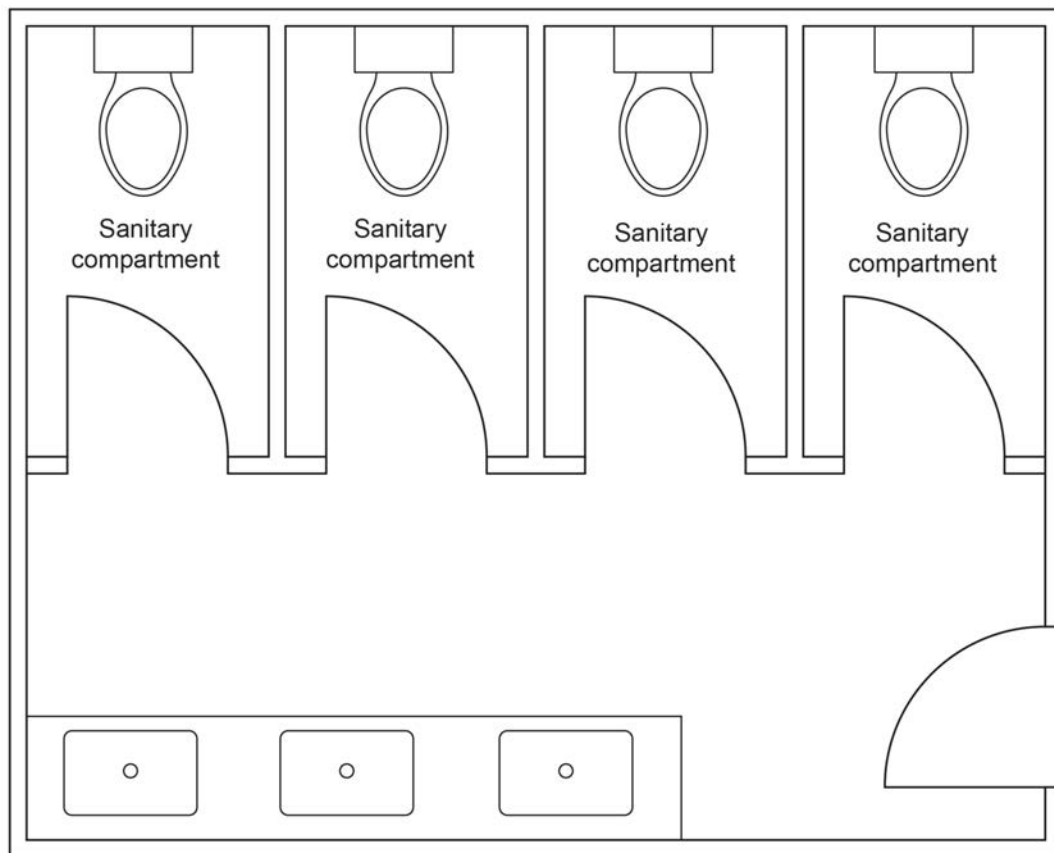
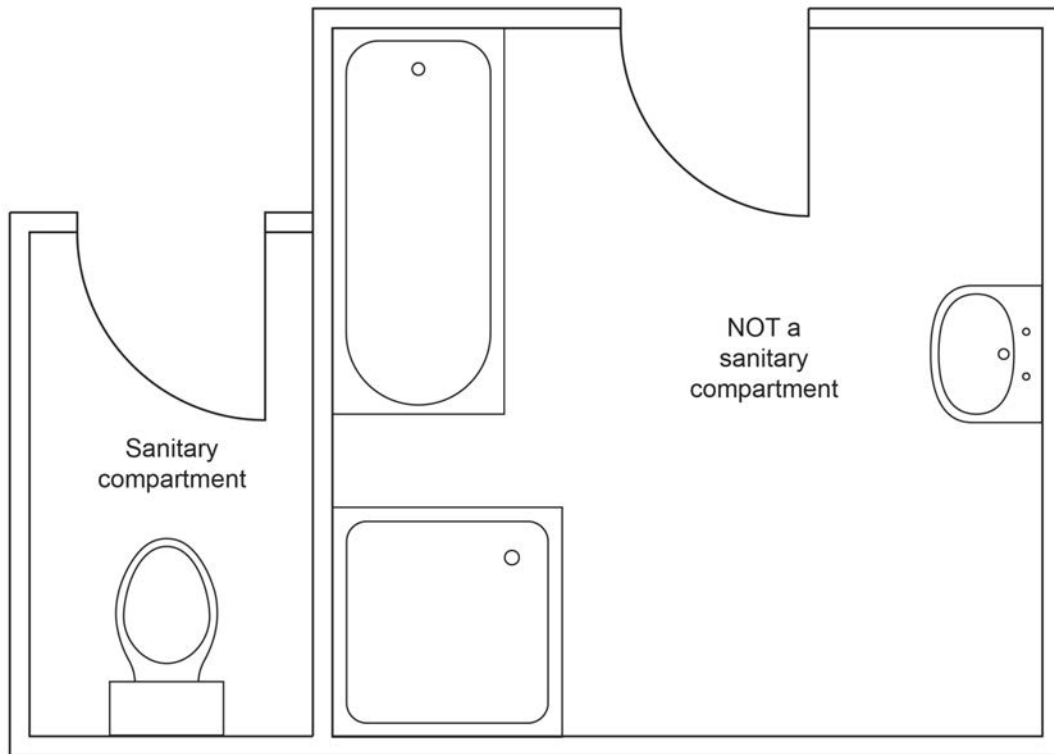

Sarking-type material

A sarking-type material is a flexible membrane that may be used for waterproofing, vapour proofing or thermal reflectance and includes reflective insulation. Commonly used terms include sarking, reflective foil, building wrap and breathable

membrane.

Self-closing

Applies to doors which are smoke or fire doors and the like. In each case it is important that the doors be fitted with a device that immediately closes them after manual opening, and keeps them closed to stop the spread of fire and/or smoke during a fire situation.

Sensible heat gain

This term refers to the heat added to air to cause its temperature to rise. This can be heat from people, other than latent heat, and the heat from lights or appliances, other than the latent heat from steam generating devices.

Service

There are many services in a building, but for NCC purposes, only certain building services are regulated, and this excludes process services. Those services regulated are stated in the definition and specified in the Deemed-to-Satisfy Provisions.

Service station

An outlet which sells petrol and has an area for servicing motor vehicles. The whole service station can be classified as a Class 6 building. The definition also applies to a car dealership which contains an area for the servicing of vehicles.

Shaft

The definition includes the top and bottom as well as the walls.

Smoke-and-heat vent

Can be automatically opened as necessary, or permanently fixed open. See [Parts C2](#) and [E2](#).

Smoke-Developed Index

A test in accordance with AS/NZS 1530.3 determines the Smoke-Developed Index of a material. The index is based on a logarithmic scale of 0 to 10. A lower index number indicates better performance.

Smoke development rate

A test in accordance with AS ISO 9239.1 determines the smoke development rate of a material. A lower value indicates better performance.

Smoke growth rate index

A test in accordance with AS ISO 9705 determines the smoke growth rate index ($SMOGR_{RC}$) of a material. A lower value indicates better performance.

Sole-occupancy unit

A sole-occupancy unit is an area within a building for the exclusive use of the owner or occupier. It is irrelevant if the area is occupied by an individual, a number of people, or by a company. Exclusivity of use is the key factor in determining whether an area or room is a sole-occupancy unit.

Example

Examples of sole-occupancy units include individual flats in a block of flats, a self contained unit, a bedroom and associated ensuite, a suite of rooms in a hotel or motel, bedrooms in an aged care building, a shop in a shopping centre, or an office occupied by an individual owner or tenant in an office building. A sole-occupancy unit may also include a single bedroom or different combinations of related rooms associated with a bedroom exclusively used in a Class 3 building used for student accommodation. For example a bedroom with an associated study room and a small storage room exclusively for the use of a student would be considered a sole-occupancy unit.

In residential applications, a sole-occupancy unit will typically consist of sleeping facilities, sanitary facilities and a living area. See [Figure Schedule 3\(SOU\)](#). In situations where the sleeping facilities are the only areas that are for the exclusive use of the owner or occupier the delineation of the sole-occupancy unit will change. In this instance the bedroom becomes the sole-occupancy unit.

Areas that do not comprise a sole-occupancy unit are those intended and available for the use of more than one owner or occupier (what is often called a “common area”). Examples applying to residential type buildings include a laundry; TV room; entertainment room; and kitchen in a boarding house. See [Figure Schedule 3\(SOU\)](#).

For commercial buildings, spaces generally referred to as “common areas” may include corridors, kitchenettes, lift lobbies and sanitary facilities.

Figure Schedule 3(SOU) Sole-occupancy units contained within a Class 2 or 3 building

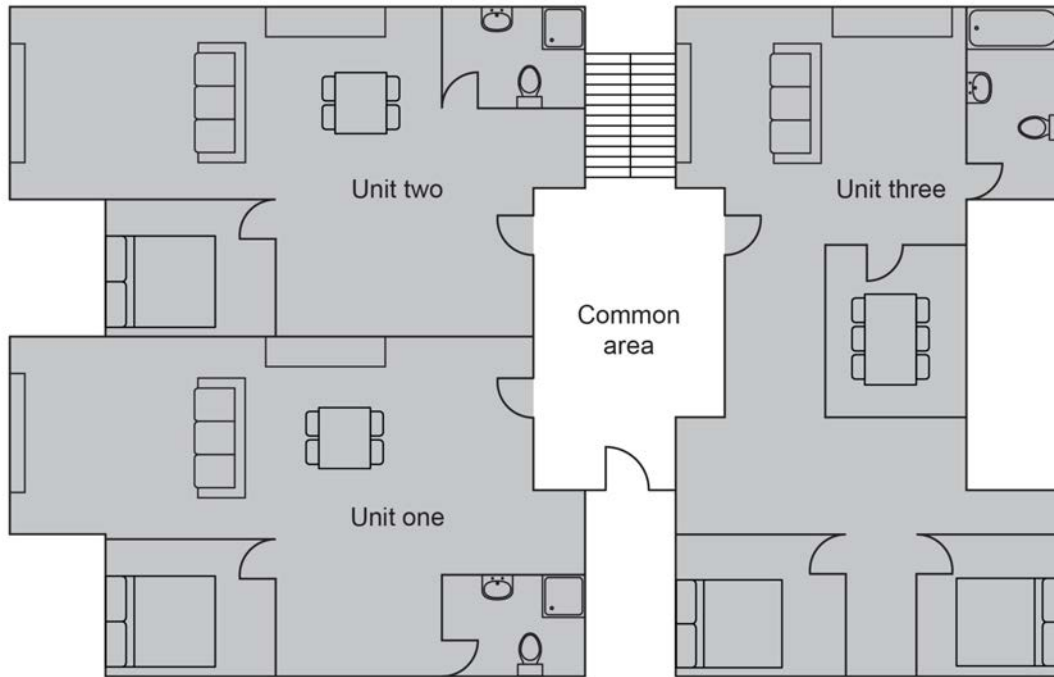

(a) Class 2 or 3 suite of rooms

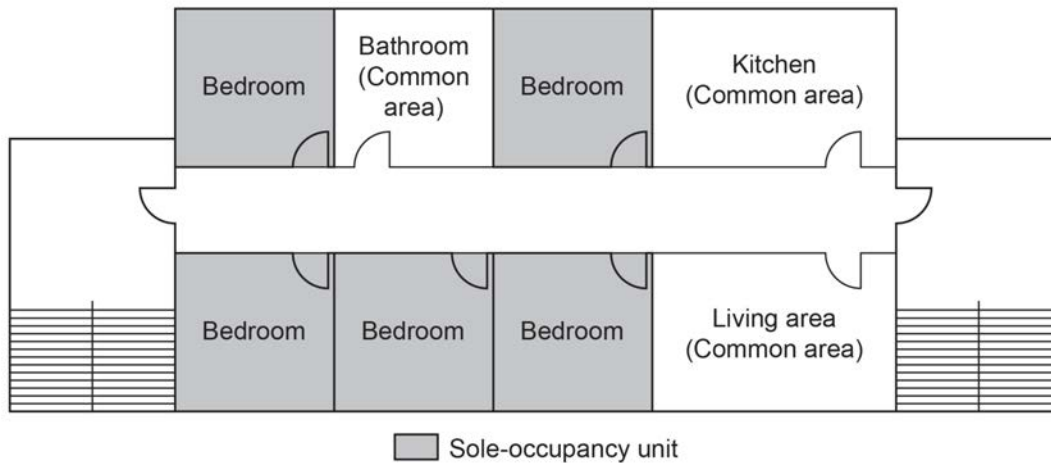

(b) Class 3 Single Bedroom

Spread-of-Flame Index

A test in accordance with AS/NZS 1530.3 determines the Spread-of-Flame Index of a material. The index is based on a logarithmic scale of 0 to 10. A lower index number indicates better performance.

Standard Fire Test

AS 1530.4 contains details of the Standard Fire Test. The test is used to determine the FRL of a building element. The results are recorded in order as: structural adequacy, integrity and insulation.

Storey

Figure Schedule 3(ST) illustrates that a storey extends from the floor level of the subject area to the floor level above, or, if the storey is at the top of the building, to the ceiling or roof. It is not unusual for people to simply regard the ceiling or the bottom of the storey above as the top of a storey.

The listed exceptions for a storey are normally small areas with a low fire load and low occupation.

Figure Schedule 3(ST) Section showing storeys in a building

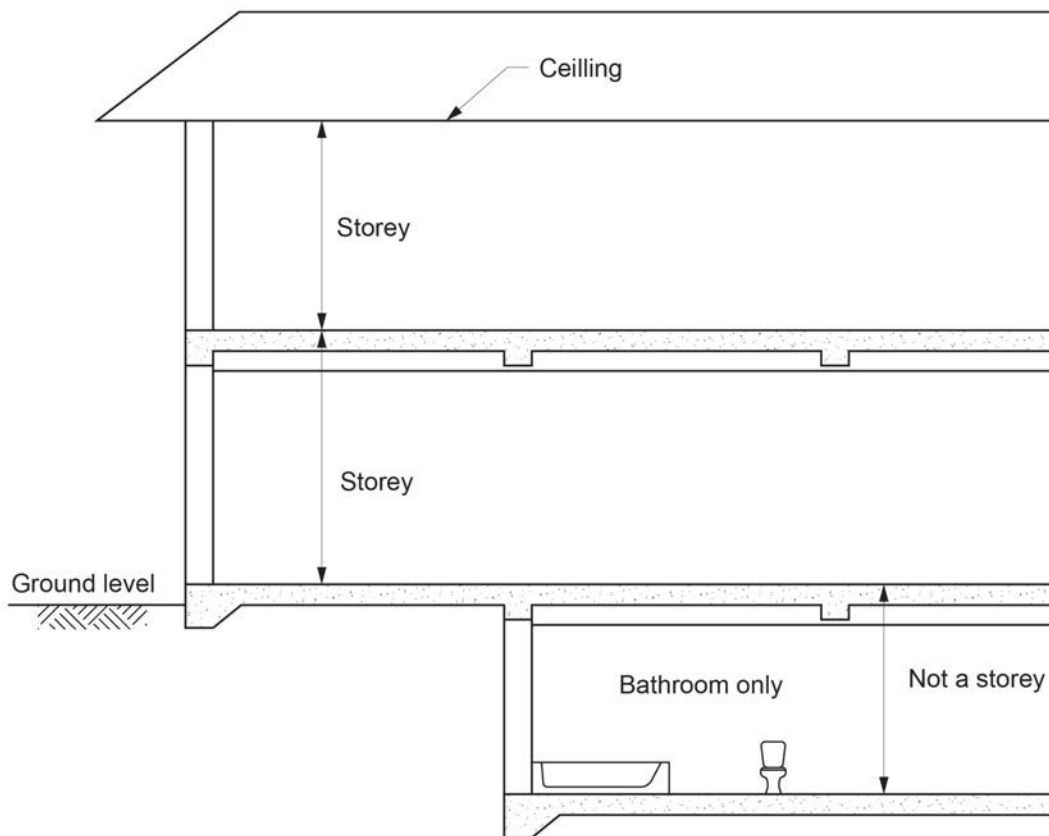

Structural adequacy

Structural adequacy is the first criterion used when specifying an FRL. It is used only in relation to the FRL of a building element. See the example under “insulation” definition.

Swimming pool

Applies to swimming and wading pools, and spas (excluding units such as spa baths emptied after each use). For provisions see [Part G1](#). These provisions do not apply to all swimming pools.

Total R-Value ($m^2.K/W$)

The definition of the Total R-Value of a thermal insulating system covers the various materials themselves and any surface coatings, air gaps or surface film resistances. As a minimum, a system must consist of a material plus two surface films, usually an outer film exposed to a wind velocity and an inner film exposed to a lower velocity. A brick veneer wall, for example, has at least five components, i.e. the outer air film, the brickwork, an air gap across the cavity, plaster lining and an inner air film. Bulk insulation in the frame cavity may be another component, while reflective insulation provides a reflective surface as well as one more air gap.

Total System Solar Heat Gain Coefficient (SHGC)

The definition of Total System Solar Heat Gain Coefficient (SHGC) has been developed to reflect the specific context in which this term is used in the NCC, and is calculated using the Technical Protocol and Procedures Manual for the Energy Rating of the Fenestration Products by the Australian Fenestration Rating Council (AFRC).

Total System U-Value ($W/m^2.K$)

U-Value is a measure of the rate of heat transfer through a material and is the reciprocal of R-Value. Total System U-Value is the reciprocal of the sum of the R-Values of individual elements. Although it applies to all materials, U-Values are generally stated for transparent and translucent materials while R-Values are generally stated for opaque materials. Transmittance is referred to for transparent and translucent materials while overall heat transfer coefficient is the general term. Total System U-Value is used in the NCC for roof lights and glazing and is calculated using the Technical Protocol and Procedures Manual for the Energy Rating of the Fenestration Products by the Australian Fenestration Rating Council (AFRC).

Treatment area

Part of a “patient-care area”. In a treatment area, a patient undergoes treatment (e.g. an operation), which may result in

the patient being unable to evacuate without assistance in an emergency such as a fire.

Unique wall

Used only in Verification Method [FV1](#) and is intended to capture walls which are neither cavity walls or use direct fixed cladding. This includes, but is not limited to, single skin walls which provide not only the outer weather protection but also act as the internal wall and may provide structural components. An example of such walls would be a concrete tilt up panel, single skin masonry or a glass curtain wall.

A unique wall is illustrated in [Figure Schedule 3\(UW\)](#).

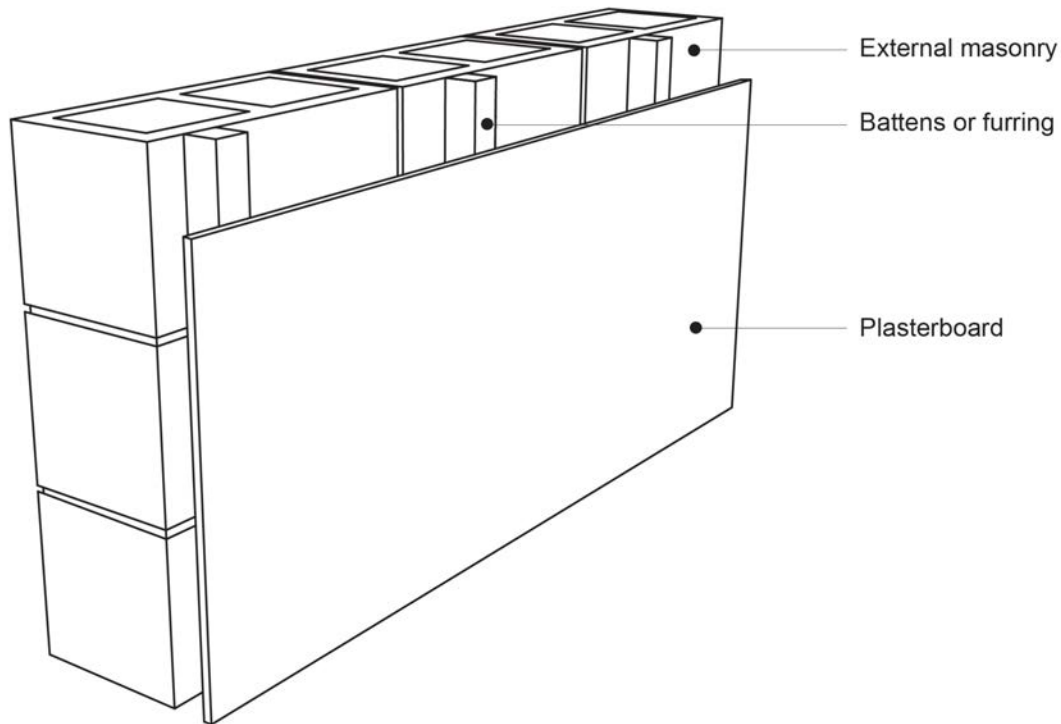
Figure Schedule 3(UW) Example of a unique wall**Verification Method**

See [Part A2](#).

Ward area

Part of a “patient-care area”. It includes a hospital or nursing-home ward and the nursing stations associated with such wards. Also, any associated living areas, such as bath and shower rooms, toilets, TV rooms, activity rooms and the like.

Window

A window must be capable of allowing light into a building, even when closed. Any transparent or translucent glass pane, brick or block, or a roof light or the like, is a window.

Referenced documents

Schedule 4 Referenced documents

Schedule 4 Documents adopted by reference

1 Schedule of referenced documents

Schedule 4 Documents adopted by reference

1 Schedule of referenced documents

Intent

Provide a listing of documents in Volume One.

The documents listed in this schedule are referenced in the Deemed-to-Satisfy Provisions of the NCC.

Referenced documents and Australian Standards

Most referenced documents are Australian Standards, prefixed by AS. Some are jointly produced with New Zealand, and these are prefixed by AS/NZS. There are several non-Australian Standards referenced, and these are found at the end of [Table 1](#).

The adoption of referenced documents

The NCC is quite precise when specifying the version of any referenced document. New, or amendments to existing referenced Australian Standards and other referenced documents are not automatically adopted.

Documents do not become part of the NCC until they have been referenced in [Table 1](#). This enables the ABCB to review the documents and make sure they are not unduly onerous or economically inappropriate before being adopted into the NCC.

How to use Table 1

Column 1 includes the number of the referenced document. In the case of some that are not Australian Standards, it includes an identifying acronym. In several cases, references are only made to specific parts of a document. Here, the relevant part number is included.

Column 2 includes the date the document was released. This distinguishes the document from earlier and later versions.

Column 3 includes the title of the referenced document. In those cases where a specific part has been referenced, the title of the part is noted. Where amendments to the document are included, the number of the amendments are listed.

Column 4 includes the NCC Volume One provision by which the document is referenced.

Column 5 includes the NCC Volume Two provision by which the document is referenced.

Column 6 includes the NCC Volume Three provision by which the document is referenced.

Referenced documents and Deemed-to-Satisfy

No referenced documents need to be used in a Performance Solution. However, a building proponent may use such documents if they wish. The documents could be used to show achievement with the Performance Requirements or equivalence with the Deemed-to-Satisfy Provisions.

Examples of reference documents other than Australian Standards

AHRI Standards

These referenced standards are published by the Air-Conditioning, Heating and Refrigeration Institute (AHRI) in the USA.

AIRAH-DA09

This referenced document is produced by The Australian Institute of Refrigeration, Air-conditioning and Heating (AIRAH) and is limited to the use of Table 2n for [Specification JVC](#).

ASTM E2073-10

The American Society for Testing and Materials (ASTM) document provides a test method to assess how photoluminescent markings perform under identical test conditions. Its use is limited to photoluminescent exit signs.

CIBSE Guide A

This referenced document is produced by The Chartered Institute of Building Services Engineers (CIBSE).

Fire-Resistance of building elements

Schedule 5 Fire-Resistance of building elements

Schedule 5 Fire resistance of building elements

- 1 Use of Schedule 5
- 2 Fire-resistance level
- 3 AS 1530.4—Standard Fire Test
- 4 Non-loadbearing elements (Clause 6 of Schedule 5)
- 5 Table 1—FRLs deemed to be achieved

Schedule 5 Fire resistance of building elements

1 Use of Schedule 5

Deemed-to-Satisfy Provisions often require building elements to have an FRL. [Schedule 5](#) explains how these FRLs are to be determined and, in conjunction with [Table 1](#), spells out how FRLs apply to specific building elements and materials.

2 Fire-resistance level

An FRL is expressed in terms of figures that cover structural adequacy, integrity and insulation.

Examples

A loadbearing wall may require an FRL of 120/60/30—meaning that in the Standard Fire Test the wall must retain its:

- structural adequacy for at least 120 minutes;
- integrity for at least 60 minutes; and
- insulation properties for at least 30 minutes.

A non-loadbearing wall, however, may require an FRL of –/120/120—meaning that in a Standard Fire Test the wall is not required to retain any structural adequacy criterion. However, the wall must maintain its:

- integrity for at least 120 minutes; and
- insulation properties for at least 120 minutes

3 AS 1530.4—Standard Fire Test

[Schedule 5](#) requires that a prototype of an element being tested must be subjected to the Standard Fire Test, ie the Fire-resistance tests of Elements of Building Construction in AS 1530.4. When the Standard Fire Test is used to determine an FRL for the purposes of assessing compliance with the Deemed-to-Satisfy Provisions, the prototype cannot be assisted by fire sprinklers or any other fire suppression system during the Standard Fire Test. This limitation does not prevent the use of tests incorporating assistance by fire suppression systems in Performance Solutions.

4 Non-loadbearing elements ([Clause 6 of Schedule 5](#))

A non-loadbearing element need not comply with an FRL's structural adequacy requirement.

5 [Table 1](#)—FRLs deemed to be achieved

Some building elements have been tested and their FRLs calculated. Where these are known, they are included in [Table 1](#).

Research results are generally available from the manufacturers who sponsor the tests. These results and other research will form the basis of future amendments to [Table 1](#).

In recent years, a number of the Standards Australia structural codes have included provisions for the calculation of FRLs. Some more complicated building elements have many combinations and permutations, and reference to specific Australian Standards is necessary.

Fire hazard properties

Schedule 6 Fire hazard properties

Schedule 6 **Fire hazard properties**

- 1 Scope
- 2 Assemblies

Schedule 6 Fire hazard properties

1 Scope

Intent

To establish the tests required by [Specification C1.10](#).

This clause deals with the testing to AS/NZS 1530.3 of an assembly of materials where the central core of the assembly is shielded from the effects of fire.

2 Assemblies

2.1 General requirements

Intent

To establish the tests required by [Specification C1.10](#).

[Clause 2.1](#) deals with the installation of an assembly of materials where the central core of the assembly is shielded from the effects of fire.

2.2 Form of test

Intent

To establish the tests required for early fire-hazard properties on assemblies of materials.

[Schedule 6](#) requires two tests in accordance with [Clause 2.2\(a\)](#) and [Clause 2.2\(b\)](#). They are respectively: AS/NZS 1530.3 for Spread-of-Flame Index and Smoke-Developed Index; and AS 1530.4 for the ability to prevent ignition and to screen the core material from free air.

The test in accordance with AS 1530.4 is conducted on assemblies, as specified in [Specification C1.10](#).

2.3 Test specimens

Intent

To specify the details required for the test specimen.

The assembly to be tested must include all joints, perforations, recesses, and the like. These parts may affect not only its early fire-hazard properties, but are also more likely to affect the passage of air and fire to the assembly's inner core. The requirements for the test specimen apply to both tests required by [Clause 2](#).

2.4 Concession

Intent

To provide a concession for the re-testing of joints, perforations, recesses, and the like which have been previously tested.

[Clause 2.4](#) is based on the assumption that [Clause 2.2](#) tests would be passed by joints, perforations and recesses, which will be smaller in the building member to be used on site than those in the member tested. The concession in [Clause 2.4](#) applies to both the tests in [Clause 2.2](#).

2.5 Smaller specimen permitted

Intent

To allow smaller test specimens when testing for the ability to prevent ignition and screen the core material from free air when appropriate.

The smaller test specimen allowed by [Clause 2.5](#) only applies to the AS 1530.4 test required by [Clause 2.2\(b\)](#).

The smaller test specimen is allowed for practical reasons in the test rig. This is on the basis that the test will

Fire hazard properties

affect the specimen in an identical manner to the on-site building member.

The results from a smaller test specimen are limited to those specified by the testing laboratory. In accordance with [Schedule 6](#), only an Accredited Testing Laboratory may conduct the test.